



Illinois Department of Transportation

Memorandum

To: Highway Standards Users
From: Jack A. Elston 
Subject: Revision #226
Date: September 2, 2022

Revision #226 of the Highway Standards, effective January 1, 2023, is now available on the department's website.

The revisions are as follows:

<u>Removed</u>	<u>Inserted</u>	<u>Remarks</u>
Division 000 Index January 1, 2022	Division 000 Index January 1, 2023	Updated.
Division 200 Index January 1, 2022	Division 200 Index January 1, 2023	Updated.
Division 300 Index January 1, 2022	Division 300 Index January 1, 2023	Updated.
Division 400 Index January 1, 2022	Division 400 Index January 1, 2023	Updated.
Division 500 Index January 1, 2022	Division 500 Index January 1, 2023	Updated.
Division 600 Index January 1, 2022	Division 600 Index January 1, 2023	Updated.
631031-17	631031-18	Removed two posts, revised blockouts, and removed notes on sheet 4.
631032-09	631032-10	Updated bridge rail connection to match the new Type SMX. Revised post spacing, blockouts, and details to match other TBTs.

<u>Removed</u>	<u>Inserted</u>	<u>Remarks</u>
631033-08	631033-09	Removed two posts and revised blockouts to be consistent with other TBTs.
631061	631061-01	Revised pay limits to end at splice.
N/A	631066	New Standard.
Division 700 Index January 1, 2022	Division 700 Index January 1, 2023	Updated.
Division 800 Index January 1, 2022	Division 800 Index January 1, 2023	Updated.
Division B.L.R. Index January 1, 2022	Division B.L.R. Index January 1, 2023	Updated.
Standards by Subject/Title January 1, 2022	Standards by Subject/Title January 1, 2023	Updated.

If you have any questions pertaining to the Highway Standards, please contact the Policy and Procedures Section in the Bureau of Design and Environment at (217) 782-7651.

January 1, 2023



Standards by Division

DIVISION 000 MISCELLANEOUS TABLES

STD. NO.	TITLE
000001-08	Standard Symbols, Abbreviations and Patterns
001001-02	Areas of Reinforcement Bars
001006	Decimal of an Inch and of a Foot

January 1, 2023



Standards by Division

DIVISION 200 EARTHWORK, LANDSCAPING, and EROSION CONTROL

STD. NO. TITLE

EARTHWORK

202001-01 Earth Median Ditch Check

EROSION CONTROL

280001-07 Temporary Erosion Control Systems

285001-02 Fabric Formed Concrete Revetment Mats

January 1, 2023



Standards by Division

DIVISION 300 SUBGRADES, SUBBASES, and BASE COURSES

STD. NO. TITLE

BASE COURSE

353001-05 PCC Base Course with HMA Binder and Surface Courses



Standards by Division

DIVISION 400 SURFACE COURSES, PAVEMENTS, REHABILITATION, AND SHOULDERS

STD. NO. TITLE**BITUMINOUS SURFACES AND HOT-MIX ASPHALT PAVEMENTS**

406001-06	Entrance Ramp Terminal (Flexible Ramp Pavement Adjacent to Flexible Mainline Pavt.)
406101-05	Exit Ramp Terminal (Flexible Ramp Pavement Adjacent to Flexible Mainline Pavement)
406201-01	Mailbox Turnout

PORTLAND CEMENT CONCRETE PAVEMENTS AND SIDEWALKS

420001-10	Pavement Joints
420101-07	24' (7.2 m) Jointed PCC Pavement
420106-07	36' (10.8 m) Jointed PCC Pavement
420111-04	PCC Pavement Roundouts
420201-12	Entrance Ramp Terminal (Jointed PCC Ramp Pavement Adjacent to Jointed PCC Mainline Pavt.)
420206-13	Entrance Ramp Terminal (Jointed PCC Ramp Pavement Adjacent to CRC Mainline Pavement)
420301-09	Exit Ramp Terminal (Jointed PCC Ramp Pavement Adjacent to Jointed PCC Mainline Pavt.)
420306-11	Exit Ramp Terminal (Jointed PCC Ramp Pavement Adjacent to CRC Mainline Pavement)
420401-13	Pavement Connector (PCC) for Bridge Approach Slab
420406	Pavement Connector (HMA) for Bridge Approach Slab
420501-07	PCC Pavement and PCC Base Course Adjacent to Railroad Grade Crossing
420701-03	Pavement Welded Wire Reinforcement
421001-03	Bar Reinforcement for CRC Pavement
421101-10	24' (7.2 m) CRC Pavement (With Wide Flange Beam Terminal Joint)
421106-10	36' (10.8 m) CRC Pavement (With Wide Flange Beam Terminal Joint)
421201-07	24' (7.2 m) CRC Pavement (With Lug System)
421206-07	36' (10.8 m) CRC Pavement (With Lug System)
424001-11	Perpendicular Curb Ramps for Sidewalks
424006-05	Diagonal Curb Ramps for Sidewalks
424011-04	Corner Parallel Curb Ramps for Sidewalks
424016-05	Mid-block Curb Ramps for Sidewalks
424021-06	Depressed Corner for Sidewalks
424026-03	Entrance / Alley Pedestrian Crossings
424031-02	Median Pedestrian Crossings

PAVEMENT REHABILITATION

442001-04	Class A Patches
442101-09	Class B Patches
442201-03	Class C and D Patches

SHOULDERS

482001-02	HMA Shoulder Adjacent to Flexible Pavement
482006-03	HMA Shoulder Adjacent to Rigid Pavement
482011-03	HMA Shoulder Strips/Shoulders With Resurfacing or Widening and Resurfacing Projects
483001-06	PCC Shoulder



Standards by Division

DIVISION 500 BRIDGES and CULVERTS

STD. NO.	TITLE
BRIDGES	
515001-04	Name Plate for Bridges
CULVERTS	
542001-06	Concrete End Sections for Pipe Culverts 15" (375 mm) thru 84" (2100 mm) Diameter
542011-02	Concrete End Sections for Elliptical Pipe Culverts 15" (375 mm) thru 72" (1800 mm) Equivalent Diameter
542201-02	Reinforced Concrete End Sections for Pipe Culverts, 15" (375 mm) thru 36" (900 mm) Diameter Skewed With Roadway
542206-04	Reinforced Concrete End Sections for Pipe Culverts, 42" (1050 mm) thru 60" (1500 mm) Diameter Skewed With Roadway
542301-03	Precast Reinforced Concrete Flared End Section
542306-03	Precast Reinforced Concrete Elliptical Flared End Section
542311-07	Traversable Pipe Grate for Concrete End Section
542401-04	Metal Flared End Section for Pipe Culverts
542406-04	Metal Flared End Section for Pipe Arches
542411	Sloped Metal End Sections for Pipe Culverts 15" (375 mm) thru 60" (1500 mm) Diameter
542416	Sloped Metal End Sections for Pipe Arch Culverts 15" (375 mm) thru 72" (1800 mm) Equivalent Diameter
542501-02	Inlet Box Type 24 (600) A
542506-03	Inlet Box Type 24 (600) B
542511-02	Inlet Box Type 24 (600) C
542516-03	Inlet Box Type 24 (600) D
542521-02	Inlet Box Type 24 (600) E
542526-03	Inlet Box Type 24 (600) F
542531-04	Inlet Box Type 24 (600) G
542536-03	Inlet Box Type 36 (900) A
542541-02	Inlet Box Type 48 (1200) A
542546-01	Flush Inlet Box for Median
542601-03	Reinforced Concrete Pipe Elbow 24", 30" or 36" (600 mm, 750 mm or 900 mm)
542606-02	Reinforced Concrete Pipe Tee



DIVISION 600 INCIDENTAL CONSTRUCTION

STD. NO.	TITLE
DRAINAGE RELATED ITEMS	
601001-05	Pipe Underdrains
601101-02	Concrete Headwall for Pipe Underdrain
602001-02	Catch Basin, Type A
602006-04	Catch Basin, Type B
602011-02	Catch Basin, Type C
602016-02	Catch Basin, Type D
602106-03	Drainage Structures, Types 4 & 5
602301-04	Inlet, Type A
602306-03	Inlet, Type B
602401-07	Precast Manhole, Type A, 4' (1.22 m) Diameter
602402-03	Precast Manhole, Type A, 5' (1.52 m) Diameter
602406-11	Precast Manhole, Type A, 6' (1.83 m) Diameter
602411-09	Precast Manhole, Type A, 7' (2.13 m) Diameter
602416-09	Precast Manhole, Type A, 8' (2.44 m) Diameter
602421-09	Precast Manhole, Type A, 9' (2.74 m) Diameter
602426-03	Precast Manhole, Type A, 10' (3.05 m) Diameter
602501-06	Precast Valve Vault, Type A, 4' (1.22 m) Diameter
602506-03	Precast Valve Vault, Type A, 5' (1.52 m) Diameter
602601-06	Precast Reinforced Concrete Flat Slab Top
602701-02	Manhole Steps
604001-05	Frame and Lids, Type 1
604006-05	Frame and Grate, Type 3
604011-05	Frame and Grate, Type 3V
604016-04	Frame and Grate, Type 4
604021-04	Base, Frame and Lids, Type 5
604026-03	Frame and Grate, Type 6
604031-03	Grate, Type 7
604036-03	Grate, Type 8
604041-03	Frame and Grate, Type 9
604046-03	Frame and Grate, Type 10
604051-04	Frame and Grate, Type 11
604056-04	Frame and Grate, Type 11V
604061-03	Frame and Grate, Type 12
604066-02	Frame and Lid, Type 15
604071-07	Frame and Grate, Type 20
604076-06	Frame and Grate, Type 21
604081-06	Frames and Grates, Type 22
604086-05	Frame and Grate, Type 23
604091-05	Frame and Grate, Type 24

604101-01	Median Inlet for 24" (600 mm) Reinforced Concrete Pipe
604106-01	Median Inlet for 36" (900 mm) Reinforced Concrete Pipe
606001-08	Concrete Curb Type B and Combination Concrete Curb and Gutter
606006-04	Outlet for Concrete Curb and Gutter, Type B-6.24 (B-15.60)
606101-05	Type A Gutter (Inlet, Outlet, and Entrance)
606106-05	Outlet, Type I for Type A Gutter
606111-03	Outlets, Type 2 for Type A Gutter
606201-04	Type B Gutter (Inlet, Outlet, and Entrance)
606206-04	Outlet, Type 1 for Type B Gutter
606211-04	Outlets, Type 2 for Type B Gutter
606301-04	PC Concrete Islands And Medians
606306-04	Corrugated PC Concrete Medians
606401-02	Paved Ditch
610001-09	Shoulder Inlet With Curb

SAFETY RELATED ITEMS

630001-12	Steel Plate Beam Guardrail
630006	Non-blocked Steel Plate Beam Guardrail
630101-10	Strong Post Guardrail Attached to Culvert
630106-02	Long-Span Guardrail Over Culvert
630111-01	Weak Post Guardrail Attached to Culvert
630116	Back Side Protection of Guardrail
630201-07	PCC/HMA Stabilization at Steel Plate Beam Guardrail
630301-09	Shoulder Widening for Type 1 (Special) Guardrail Terminals
631006-08	Traffic Barrier Terminal, Type 1B
631011-10	Traffic Barrier Terminal, Type 2
631026-06	Traffic Barrier Terminal, Type 5
631031-18	Traffic Barrier Terminal, Type 6
631032-10	Traffic Barrier Terminal, Type 6A
631033-09	Traffic Barrier Terminal, Type 6B
631046-04	Traffic Barrier Terminal, Type 10
631051-03	Traffic Barrier Terminal, Type 11
631061-01	Traffic Barrier Terminal, Type 13
631066	Traffic Barrier Terminal, Type 14
635001-02	Delineators
636001-02	Cable Road Guard Single Strand
637006-05	Concrete Barrier Double Face, 44 in. (1120 mm) Height
638101-02	Concrete Glare Screen
639001-02	Sight Screen Precast Prestressed Concrete Panel Wall
640001-01	Sight Screen Chain Link Fence
641001-01	Sight Screen Cedar Stockade Fence Type S
641006-01	Sight Screen Wood Plank Fence Type P
642001-03	Shoulder Rumble Strips, 16 in.
642006-01	Shoulder Rumble Strips, 8 in.
643001-02	Sand Module Impact Attenuators

OTHER ITEMS

664001-02	Chain Link Fence
665001-02	Woven Wire Fence
666001-01	Right-of-Way Markers
667001-01	Drainage Markers

667101-02
668001-01

Permanent Survey Markers
U.S. Geological Survey and National Geodetic Survey Benchmarks, Resetting Method



Standards by Division

**DIVISION 700 WORK ZONE TRAFFIC CONTROL AND PROTECTION,
SIGNING, AND PAVEMENT MARKING**

STD. NO.	TITLE
WORK ZONE TRAFFIC CONTROL AND PROTECTION	
701001-02	Off-Road Operations, 2L, 2W, More Than 15' (4.5 m) Away
701006-05	Off-Road Operations, 2L, 2W, 15' (4.5 m) to 24" (600 mm) From Pavement Edge
701011-04	Off-Road Moving Operations, 2L, 2W, Day Only
701101-05	Off-Road Operations, Multilane, 15' (4.5 m) to 24" (600 mm) From Pavement Edge
701106-02	Off-Road Operations, Multilane, More Than 15' (4.5 m) Away
701201-05	Lane Closure, 2L, 2W, Day Only, for Speeds \geq 45 MPH
701206-05	Lane Closure, 2L, 2W, Night Only, for Speeds \geq 45 MPH
701301-04	Lane Closure, 2L, 2W, Short Time Operations
701306-04	Lane Closure, 2L, 2W, Slow Moving Operations Day Only, for Speeds \geq 45 MPH
701311-03	Lane Closure, 2L, 2W, Moving Operations - Day Only
701316-13	Lane Closure, 2L, 2W, Bridge Repair, for Speeds \geq 45 MPH
701321-18	Lane Closure, 2L, 2W, Bridge Repair with Barrier
701326-04	Lane Closure, 2L, 2W, Pavement Widening, for Speeds \geq 45 MPH
701331-05	Lane Closure, 2L, 2W, With Run-Around, for Speeds \geq 45 MPH
701336-07	Lane Closure, 2L, 2W, Work Areas in Series, for Speeds \geq 45 MPH
701400-11	Approach to Lane Closure, Freeway/Expressway
701401-13	Lane Closure, Freeway/Expressway
701402-12	Lane Closure, Freeway/Expressway, with Barrier
701406-13	Lane Closure, Freeway/Expressway, Day Operations Only
701411-09	Lane Closure, Multilane, at Entrance or Exit Ramp, for Speeds \geq 45 MPH
701416-11	Lane Closure, Freeway/Expressway, with Crossover and Barrier
701421-08	Lane Closure, Multilane, Day Operations Only, for Speeds \geq 45 MPH to 55 MPH
701422-10	Lane Closure, Multilane, for Speeds \geq 45 MPH to 55 MPH
701423-10	Lane Closure, Multilane, with Barrier, for Speeds \geq 45 MPH to 55 MPH
701426-09	Lane Closure, Multilane, Intermittent or Moving Operation, for Speeds \geq 45 MPH
701427-05	Lane Closure, Multilane, Intermittent or Moving Operation, for Speeds \leq 40 MPH
701428-01	Traffic Control, Setup and Removal, Freeway/Expressway
701431-13	Lane Closure, Multilane, Undivided with Crossover, for Speeds \geq 45 MPH to 55 MPH
701446-11	Two Lane Closure, Freeway/Expressway
701451-05	Ramp Closure Freeway/Expressway
701456-05	Partial Exit Ramp Closure Freeway/Expressway
701501-06	Urban Lane Closure, 2L, 2W, Undivided
701502-09	Urban Lane Closure, 2L, 2W, with Bidirectional Left Turn Lane
701601-09	Urban Lane Closure, Multilane, 1W or 2W with Nontraversable Median
701602-10	Urban Lane Closure, Multilane, 2W with Bidirectional Left Turn Lane
701606-10	Urban Single Lane Closure, Multilane, 2W with Mountable Median
701611-01	Urban Half Road Closure, Multilane, 2W with Mountable Median
701701-10	Urban Lane Closure, Multilane Intersection

701801-06 Sidewalk, Corner or Crosswalk Closure
701901-08 Traffic Control Devices
704001-08 Temporary Concrete Barrier

SIGNING

720001-01 Sign Panel Mounting Details
720006-04 Sign Panel Erection Details
720011-01 Metal Posts for Signs, Markers and Delineators
720016-04 Mast Arm Mounted Street Name Signs
720021-03 Sign Panels, Extruded Aluminum Type
725001-01 Object and Terminal Markers
728001-01 Telescoping Steel Sign Support
729001-01 Applications of Types A and B Metal Posts (For Signs & Markers)
731001-01 Base for Telescoping Steel Sign Support

PAVEMENT MARKING

780001-05 Typical Pavement Markings
781001-04 Typical Applications Raised Reflective Pavement Markers
782001-01 Curb Reflectors
782006-01 Guardrail and Barrier Wall Reflector Mounting Details



DIVISION 800 ELECTRICAL

STD. NO. TITLE**GENERAL ELECTRICAL REQUIREMENTS**

805001-01 Electrical Service Installation Details

WIREWAY AND CONDUIT SYSTEMS

812001-01 Raceways Embedded in Structure

814001-03 Handholes

814006-03 Double Handholes

LIGHTING – LUMINAIRES

821001 Underpass Lighting Wall Mount

821006 Underpass Lighting Suspended

821101-02 Luminaire Wiring in Pole

LIGHTING – CONTROLLERS

825001-04 Lighting Controller, Pole Mounted, 240V

825006-03 Lighting Controller, Pole Mounted, 480V

825011-04 Lighting Controller, Pedestal Mounted, 240V

825016-04 Lighting Controller, Pedestal Mounted, 480V

825021-04 Lighting Controller, Base Mounted, 240V

825026-04 Lighting Controller, Base Mounted, 480V

826001-03 Obstruction Warning Lighting Controller, 240V

826006-03 Obstruction Warning Lighting Controller, 480V

LIGHTING – POLES

830001-03 Light Pole Aluminum Mast Arm

830006-05 Light Pole Aluminum Davit Arm

830011-03 Light Pole Steel Mast Arm

830016-03 Light Pole Steel Davit Arm

830021-03 Light Pole Steel Tenon Top

830026-01 Temporary Roadway Lighting

LIGHTING – TOWERS

835001-01 Light Tower

LIGHTING – FOUNDATIONS

836001-04 Light Pole Foundation

836011-02 Light Pole Foundation with 44 in. (1120 mm) Concrete Barrier

837001-05 Light Tower Foundation

LIGHTING – BREAKAWAY DEVICES

838001-01 Breakaway Devices

TRAFFIC SIGNALS - CONTROLLERS AND EQUIPMENT

857001-01 Standard Phase Designation Diagrams and Phase Sequences

857006-01 Supervised Railroad Interconnect Circuit

862001-01 Uninterruptable Power Supply (UPS)

TRAFFIC SIGNALS - WIRE AND CABLE

873001-02 Traffic Signal Grounding & Bonding

TRAFFIC SIGNALS - POSTS AND FOUNDATIONS

876001-04 Pedestrian Push Button Post

877001-08 Steel Mast Arm Assembly and Pole 16' Through 55'

877002-04 Steel Mast Arm Assembly and Pole 56' Through 75'

877006-06 Steel Mast Arm Assembly and Pole with Dual Mast Arms

877011-10 Steel Combination Mast Arm Assembly and Pole 16' Through 55'

877012-07 Steel Combination Mast Arm Assembly and Pole 56' Through 75'

878001-11 Concrete Foundation Details

TRAFFIC SIGNALS - SIGNAL HEADS

880001-01 Span Wire Mounted Signals and Flashing Beacon Installation

880006-01 Traffic Signal Mounting Details

TRAFFIC SIGNALS - DETECTION

886001-01 Detector Loop Installations

886006-01 Typical Layout for Detection Loops



Standards by Division

DIVISION BLR LOCAL ROADS

STD. NO.	TITLE
BLR 10-8	PCC Pavement Special
BLR 14-13	Portland Cement Concrete Pavement (Nonreinforced)
BLR 17-4	Traffic Control Devices - Day Labor Construction
BLR 18-6	Traffic Control Devices - Day Labor Maintenance
BLR 20-7	Traffic Barrier Terminal - Type 5R
BLR 21-9	Typical Application of Traffic Control Devices for Construction on Rural Local Highways
BLR 22-7	Typ. Appl. of T.C.D. for Rural Loc. Hwys. (2-Lane 2 Way Rural Traff.) (Rd. Closed to Thru Traff.)
BLR 23-4	Traffic Barrier Terminal Type 1
BLR 24-2	Mailbox Turnout for Local Roads
BLR 25-1	Type 1A Barricade for Non-NHS Routes
BLR 26-3	Steel Plate Beam Guardrail 29 in. (731 mm) Height
BLR 27-1	Traffic Barrier Terminal Type 5A
BLR 28-1	Concrete Curb Type B and Combination Concrete Curb and Gutter



<u>SUBJECT/TITLE</u>	<u>STD. NO.</u>
A	
Abbreviations, Symbols and Patterns.....	000001
B	
Barricade, Type 1A for Non-NHS Routes.....	BLR 25
Barrier, Concrete, Double Face, 44 in. (1120 mm) Height.....	637006
Barrier, Concrete, Temporary.....	704001
Base Course, PCC with HMA Binder and Surface Courses.....	353001
Benchmarks, Method of Resetting.....	668001
C	
Cable, Road Guard, Single Strand.....	636001
Catch Basin, Type A.....	602001
Catch Basin, Type B.....	602006
Catch Basin, Type C.....	602011
Catch Basin, Type D.....	602016
Circuit, Supervised Railroad Interconnect.....	857006
Curb, Concrete Type B and Combination Concrete Curb and Gutter.....	606001
Curb, Concrete Type B and Combination Concrete Curb and Gutter.....	BLR 28
Curb Ramps for Sidewalks, Corner Parallel.....	424011
Curb Ramps for Sidewalks, Diagonal.....	424006
Curb Ramps for Sidewalks, Mid-block.....	424016
Curb Ramps for Sidewalks, Perpendicular.....	424001
D	
Decimal Equivalents of an Inch and Foot.....	001006
Delineators.....	635001
Depressed Corner for Sidewalks.....	424021
Detection Loops, Typical Layout.....	886006
Detector Loop Installations.....	886001
Ditch, Paved.....	606401
Ditch Check, Earth Median.....	202001
Drainage Structures, Types 4 & 5.....	602106
E	
Elbow, Concrete Pipe, 24 in. (600 mm), 30 in. (750 mm) or 36 in. (900) Diameter.....	542601
Electrical Service Installation Details.....	805001
End Section, Flared, Precast Reinforced Concrete, Elliptical.....	542306
End Section, Flared, Precast Reinforced Concrete, Round.....	542301
End Section, Metal Flared, for Pipe Arches.....	542406
End Section, Metal Flared, for Pipe Culverts.....	542401
End Sections, Sloped Metal, for Pipe Culverts 15" (375 mm) thru 60" (1500 mm) Dia.....	542411

End Sections, Sloped Metal, for Pipe Arch Culverts 15" (375 mm) thru 72" (1800 mm) Dia. ...542416

End Sections, Reinforced Concrete:

- Pipe Culverts, 15 in. (375 mm) thru 84 in. (2100 mm) Diameter542001
- Pipe Culverts, Elliptical, 15 in. (375 mm) thru 72 in. (1800 mm) Equivalent Diameter542011
- Skewed, for 15 in. (375 mm) thru 36 in. (900 mm) Diameter542201
- Skewed, for 42 in. (1050 mm) thru 60 in. (1500 mm) Diameter542206

Erosion Control Systems, Temporary.....280001

F

Fence, Chain Link664001

Fence, Woven Wire665001

Flashing Beacon Installation880001

Flat Slab Top, Precast Reinforced Concrete602601

Foundations, Details, Concrete878001

Frames, Grates and Lids:

- Type 1 Frame and Lids604001
- Type 3 Frame and Grate604006
- Type 3V Frame and Grate.....604011
- Type 4 Frame and Grate604016
- Type 5 Base, Frame and Lids604021
- Type 6 Frame and Grate604026
- Type 7 Grate604031
- Type 8 Grate604036
- Type 9 Frame and Grate604041
- Type 10 Frame and Grate604046
- Type 11 Frame and Grate604051
- Type 11V Frame and Grate.....604056
- Type 12 Frame and Grate604061
- Type 15 Frame and Lid604066
- Type 20 Frame and Grate604071
- Type 21 Frame and Grate604076
- Type 22 Frames and Grates.....604081
- Type 23 Frame and Grate604086
- Type 24 Frame and Grate604091

G

Glare Screen, Concrete638101

Grate, Traversable Pipe for Concrete End Section.....542311

Guardrail:

- Protection of Back Side of630116
- Long Span Over Culverts630106
- Steel Plate Beam,630001
- Steel Plate Beam, 29 in. (731 mm) Height.....BLR 26
- Steel Plate Beam, Non-Blocked630006
- Steel Plate Beam, PCC/HMA Stabilization630201
- Strong Post, Attached to Culvert630101
- Weak Post, Attached to Culvert.....630111

H

Handholes, Concrete and Polymer Concrete, Double	814006
Handholes, Polymer Concrete, Single.....	814001
Headwall for Pipe Underdrains, Concrete	601101

I

Impact Attenuators, Sand Module	643001
Inlet:	
For 24 in. (600 mm) Reinforced Concrete Pipe in Median	604101
For 36 in. (900 mm) Reinforced Concrete Pipe in Median	604106
For Shoulder With Curb.....	610001
For Type B Gutter	606201
Outlet & Entrance for Type A Gutter.....	606101
Type A.....	602301
Type B.....	602306
Inlet Box:	
Flush for Median	542546
Type 24 (600) A	542501
Type 24 (600) B	542506
Type 24 (600) C	542511
Type 24 (600) D	542516
Type 24 (600) E	542521
Type 24 (600) F.....	542526
Type 24 (600) G	542531
Type 24 (900) A	542536
Type 48 (1200) A	542541
Islands, Concrete	606301

J/K

Joints, Pavement	420001
------------------------	--------

L

Lane Closure	(see Traffic Control and Protection)
Lighting Controller, Pole Mounted, 240V	825001
Lighting Controller, Pole Mounted, 480V	825006
Lighting Controller, Pedestal Mounted, 240V	825011
Lighting Controller, Pedestal Mounted, 480V	825016
Lighting Controller, Base Mounted, 240V	825021
Lighting Controller, Base Mounted, 480V	825026
Lighting Controller, Obstruction Warning, 240V.....	826001
Lighting Controller, Obstruction Warning, 480V.....	826006
Lighting, Underpass, Suspended	821006
Lighting, Underpass, Wall Mount	821001
Light Pole, Aluminum, Mast Arm	830001
Light Pole, Aluminum, Davit Arm.....	830006
Light Pole, Breakaway Devices.....	838001
Light Pole, Steel, Mast Arm.....	830011
Light Pole, Steel, Davit Arm	830016
Light Pole, Steel, Tenon Top.....	830021
Light Tower	835001
Light Pole Foundation	836001

Light Pole Foundation with 44 in. (1120 mm) Concrete Barrier836011
 Light Tower Foundation837001
 Luminaire Wiring in Pole821101

M

Mailbox Turnout, Local System BLR-24
 Mailbox Turnout, State System406201
 Manhole, Precast, Type A, 4 ft. (1.22 m) Diameter.....602401
 Manhole, Precast, Type A, 5 ft. (1.52 m) Diameter.....602402
 Manhole, Precast, Type A, 6 ft. (1.83 m) Diameter.....602406
 Manhole, Precast, Type A, 7 ft. (2.13 m) Diameter.....602411
 Manhole, Precast, Type A, 8 ft. (2.44 m) Diameter.....602416
 Manhole, Precast, Type A, 9 ft. (2.74 m) Diameter.....602421
 Manhole, Precast, Type A, 10 ft. (3.05 m) Diameter.....602426
 Manhole Steps.....602701
 Markers:
 Drainage667001
 Permanent Survey667101
 Right-of-Way666001
 Mast Arm Assembly and Pole 16' Through 55', Steel Combination877011
 Mast Arm Assembly and Pole 56' Through 75', Steel Combination877012
 Mast Arm Assembly and Pole, Steel, Dual Mast Arms877006
 Mast Arm Assembly and Pole 16' Through 55', Steel.....877001
 Mast Arm Assembly and Pole 56' Through 75', Steel.....877002
 Mast Arm Mounted Street Name Signs720016
 Median, Concrete.....606301
 Median, Concrete, Corrugated606306

N

Name Plates for Bridges515001

O

Object and Terminal Markers725001
 Outlet:
 Inlet and entrance for Type A Gutter606101
 Type 1, for Type A Gutter606106
 Type 1, for Type B Gutter606206
 Type 2, for Type A Gutter606111
 Type 2, for Type B Gutter606211
 Type B-6.24 (B-15.60) for Concrete Curb and Gutter606006
 For Type B Gutter, Standard606201

P/Q

Patching, Class A.....442001
 Patching, Class B.....442101
 Patching, Class C and D442201

Pavement:

24' (7.2 m) Continuously Reinforced PCC With Lug System421201
 24' (7.2 m) Continuously Reinforced PCC With Wide Flange Beam Term. Joint421101

24' (7.2 m) Jointed PCC	420101
36' (10.8 m) Continuously Reinf. PCC With Wide Flange Beam Term. Joint	421106
36' (10.8 m) Continuously Reinforced PCC With Lug System.....	421206
36' (10.8 m) Jointed PCC	420106
Adjacent to Railroad Grade Crossing, PCC.....	420501
Connector (HMA) for Bridge Approach Slab.....	420406
Connector (PCC) for Bridge Approach Slab	420401
Nonreinforced PCC	BLR 14
Reinforcement for Continuously Reinforced PCC Pavement	421001
Roundouts, PCC	420111
Special, PCC.....	BLR 10
Welded Wire Reinforcement.....	420701
Pavement Markers, Raised Reflective, Applications	781001
Pavement Markings	780001
Pedestrian Crossings, Entrance / Alley	424026
Pedestrian Crossings, Median	424031
Phase Sequences.....	857001
Pipe Underdrains	601001
Posts, Metal, Applications for Type A and B.....	729001
Posts, Metal, for Signs, Markers and Delineators.....	720011
Push Button Post	876001

R

Raceways Embedded in Structure	812001
Ramp Closure, Freeway/Expressway	701451
Ramp Closure, Partial Exit, Freeway/Expressway.....	701456
Ramp Terminal:	
Entrance, Flexible Adjacent to Flexible Mainline Pavement.....	406001
Entrance, Jointed PCC Adjacent to CRC Mainline Pavement.....	420206
Entrance, Jointed PCC Adjacent to Jointed PCC Mainline Pavement	420201
Exit, Flexible Adjacent to Flexible Mainline Pavement	406101
Exit, Jointed PCC Adjacent to CRC Mainline Pavement.....	420306
Exit, Jointed PCC Adjacent to Jointed PCC Mainline Pavement.....	420301
Reflector Mounting Details, Guardrail and Barrier Wall	782006
Reflectors, Curb.....	782001
Reinforcement Bars, Areas, Weights and Spacing.....	001001
Revetment Mat, Fabric Formed Concrete	285001
Rumble Strips, Shoulder, 16 inch.....	642001
Rumble Strips, Shoulder, 8 inch.....	642006

S

Shoulder:	
Adjacent to Flexible Pavement, HMA	482001
Adjacent to Rigid Pavement, HMA	482006
PCC	483001
or Shoulder Strips With Resurfacing or Widening and Resurfacing Projects	482011
Sidewalks, Corner Parallel Curb Ramps for	424011
Sidewalks, Diagonal Curb Ramps for.....	424006
Sidewalks, Mid-block Curb Ramps for.....	424016
Sidewalks, Perpendicular Curb Ramps for	424001
Sight Screen, Chain Link Fence.....	640001

Sight Screen, Concrete Panel Wall, Precast Prestressed	639001
Sight Screen, Wood Fence, Cedar Stockade	641001
Sight Screen, Wood Fence, Wood Plank	641006
Sign Panel, Erection Details	720006
Sign Panel, Extruded Aluminum Type	720021
Sign Panel, Mounting Details	720001
Sign Support, Telescoping Steel	728001
Sign Support, Telescoping Steel, Base for	731001
Symbols, Abbreviations, and Patterns.....	000001

T

Tee, Concrete Pipe	542606
Traffic Barrier Terminal:	
Type 1	BLR-23
Type 1B.....	631006
Type 1 Special, Shoulder Widening for	630301
Type 2	631011
Type 5A.....	BLR 27
Type 5R	BLR 20
Type 6	631031
Type 6A.....	631032
Type 6B.....	631033
Type 10	631046
Type 11	631051
Type 13	631061
Type 14	631066
Traffic Control:	
Devices	701901
Devices:	
Type 1A Barricade for Non-NHS Routes	BLR 25
Day Labor Construction.....	BLR 17
Day Labor Maintenance	BLR 18
Typical Application of, for Construction on Rural Local Highways.....	BLR 21
Typical Application of, for Construction on Rural Local Highways (Two-Lane Two Way Rural Traffic) (Road Closed to Thru Traffic)	BLR 22
Lane Closure, 2L, 2W:	
Bridge Repair, for Speeds \geq 45 MPH.....	701316
Bridge Repair with Barrier.....	701321
Day Only, for Speeds \geq 45 MPH.....	701201
Moving Operations - Day Only.....	701311
Night Only, for Speeds \geq 45 MPH.....	701206
Pavement Widening, for Speeds \geq 45 MPH.....	701326
Short Time Operations	701301
Slow Moving Operations Day Only, for Speeds \geq 45 MPH.....	701306
With Run-Around, for Speeds \geq 45 MPH	701331
Work Areas in Series, for Speeds \geq 45 MPH	701336
Lane Closure, Freeway/Expressway	701401
Lane Closure, Freeway/Expressway:	
Approach to.....	701400

Day Operations Only	701406
Sidewalk, Corner or Crosswalk Closure.....	701801
Two Lane Closure	701446
with Barrier	701402
with Crossover and Barrier	701416
Lane Closure, Multilane:	
at Entrance or Exit Ramp, for Speeds \geq 45 MPH.....	701411
Day Operations Only, for Speeds \geq 45 MPH to 55 MPH.....	701421
for Speeds \geq 45 MPH to 55 MPH.....	701422
Intermittent or Moving Operation, for Speeds \geq 45 MPH.....	701426
Intermittent or Moving Operation, for Speeds \leq 40 MPH.....	701427
Undivided With Crossover, for Speeds \geq 45 MPH to 55 MPH.....	701431
with Barrier, for Speeds \geq 45 MPH to 55 MPH.....	701423
Lane Closure, Urban:	
2L, 2W, Undivided	701501
2L, 2W, with Bidirectional Left Turn Lane	701502
Multilane, 1W or 2W with Nontraversable Median	701601
Multilane, 2W with Bidirectional Left Turn Lane	701602
Multilane, Single Lane Closure, 2W with Mountable Median.....	701606
Multilane, Half Road, Closure, 2W with Mountable Median.....	701611
Multilane Intersection.....	701701
Off-Road Operations:	
2L 2W, 15 ft. (4.5 m) to 24 in (600 mm) From Pavement Edge.....	701006
2L 2W, More Than 15 ft. (4.5 m) Away	701001
Moving, 2L 2W, Day Only	701011
Multilane, 15 ft. (4.5 m) to 24 in. (600 mm) From Pavement Edge	701101
Multilane, More Than 15 ft. (4.5 m) Away	701106
Setup and Removal, Freeway/Expressway	701428
Traffic Signal Grounding & Bonding	873001
Traffic Signal Mounting Details, Post and Bracket Mounted	880006
Traffic Signal Mounting Details, Span Wire Mounted and Flashing Beacon	880001
U-Z	
Uninterruptable Power Supply (UPS).....	862001
Valve Vault, Precast, Type A, 4 ft. (1.22 m) Diameter	602501
Valve Vault, Precast, Type A, 5 ft. (1.52 m) Diameter	602506

ABV	ABOVE	CU YD	CUBIC YARD	HATCH	HATCHING	PM	PAVEMENT MARKING	STD	STANDARD
A/C	ACCESS CONTROL	CULV	CULVERT	HD	HEAD	PED	PEDESTAL	SBI	STATE BOND ISSUE
AC	ACRE	C&G	CURB & GUTTER	HDW	HEADWALL	PNT	POINT	SR	STATE ROUTE
ADJ	ADJUST	D	DEGREE OF CURVE	HDUTY	HEAVY DUTY	PC	POINT OF CURVATURE	STA	STATION
AS	AERIAL SURVEYS	DC	DEPRESSED CURVE	ha	HECTARE	PI	POINT OF INTERSECTION OF HORIZONTAL CURVE	SPBGR	STEEL PLATE BEAM GUARDRAIL
AGG	AGGREGATE	DET	DETECTOR	HMA	HOT MIX ASPHALT	PRC	POINT OF REVERSE CURVE	SS	STORM SEWER
AH	AHEAD	DIA	DIAMETER	HWY	HIGHWAY	PT	POINT OF TANGENCY	STY	STORY
APT	APARTMENT	DIST	DISTRICT	HORIZ	HORIZONTAL	POT	POINT ON TANGENT	ST	STREET
ASPH	ASPHALT	DOM	DOMESTIC	HSE	HOUSE	POLYETH	POLYETHYLENE	STR	STRUCTURE
AUX	AUXILIARY	DBL	DOUBLE	IL	ILLINOIS	PCC	PORTLAND CEMENT CONCRETE	e	SUPERELEVATION RATE
AGS	AUXILIARY GAS VALVE (SERVICE)	DSEL	DOWNSTREAM ELEVATION	IMP	IMPROVEMENT	PP	POWER POLE OR PRINCIPAL POINT	S.E. RUN.	SUPERELEVATION RUNOFF LENGTH
AVE	AVENUE	DSFL	DOWNSTREAM FLOWLINE	IN DIA	INCH DIAMETER	PRM	PRIME	SURF	SURFACE
AX	AXIS OF ROTATION	DR	DRAINAGE OR DRIVE	INL	INLET	PE	PRIVATE ENTRANCE	SMK	SURVEY MARKER
BK	BACK	DI	DRAINAGE INLET OR DROP INLET	INST	INSTALLATION	PE	PRIVATE ENTRANCE	T	TANGENT DISTANCE
B-B	BACK TO BACK	DRV	DRIVEWAY	IDS	INTERSECTION DESIGN STUDY	PROF	PROFILE	T.R.	TANGENT RUNOUT DISTANCE
BKPL	BACKPLATE	DCT	DUCT	INV	INVERT	PGL	PROFILE GRADELINE	TEL	TELEPHONE
B	BARN	EA	EACH	IP	IRON PIPE	PROJ	PROJECT	TB	TELEPHONE BOX
BARR	BARRICADE	EB	EASTBOUND	IR	IRON ROD	P.C.	PROPERTY CORNER	TP	TELEPHONE POLE
BL	BASELINE	EOP	EDGE OF PAVEMENT	JT	JOINT	PL	PROPERTY LINE	TEMP	TEMPORARY
BGN	BEGIN	E-CL	EDGE TO CENTERLINE	kg	KILOGRAM	PR	PROPOSED	TBM	TEMPORARY BENCH MARK
BM	BENCHMARK	E-E	EDGE TO EDGE	km	KILOMETER	R	RADIUS or RESIDENTIAL	TD	TILE DRAIN
BIND	BINDER	ELEC	ELECTRICAL	LS	LANDSCAPING	RR	RAILROAD	TBE	TO BE EXTENDED
BIT	BITUMINOUS	EL	ELEVATION	LN	LANE	RRS	RAILROAD SPIKE	TBR	TO BE REMOVED
BTM	BOTTOM	ENTR	ENTRANCE	LT	LEFT	RPS	REFERENCE POINT STAKE	TBS	TO BE SAVED
BLVD	BOULEVARD	EXC	EXCAVATION	LIDAR	LIGHT DETECTION AND RANGING	REF	REFLECTIVE	TWP	TOWNSHIP
BRK	BRICK	EX	EXISTING	LP	LIGHT POLE	RCCP	REINFORCED CONCRETE CULVERT PIPE	TR	TOWNSHIP ROAD
BBOX	BUFFALO BOX	EXPWAY	EXPRESSWAY	LGT	LIGHTING	REINF	REINFORCEMENT	TS	TRAFFIC SIGNAL
BLDG	BUILDING	E	EXTERNAL DISTANCE OF HORIZONTAL CURVE	LF	LINEAL FEET OR LINEAR FEET	REM	REMOVAL	TSCB	TRAFFIC SIGNAL CONTROL BOX
CATV	CABLE	E	OFFSET DISTANCE TO VERTICAL CURVE	L	LITER OR CURVE LENGTH	RC	REMOVE CROWN	TSC	TRAFFIC SYSTEMS CENTER
CIP	CAST IRON PIPE	F-F	FACE TO FACE	LC	LONG CHORD	REP	REPLACEMENT	TRVS	TRANSVERSE
CB	CATCH BASIN	FA	FEDERAL AID	LNG	LONGITUDINAL	REST	RESTAURANT	TRVL	TRAVEL
C-C	CENTER TO CENTER	FAI	FEDERAL AID INTERSTATE	L SUM	LUMP SUM	RESURF	RESURFACING	TRN	TURN
CL	CENTERLINE OR CLEARANCE	FAP	FEDERAL AID PRIMARY	MACH	MACHINE	RET	RETAINING	TY	TYPE
CL-E	CENTERLINE TO EDGE	FAS	FEDERAL AID SECONDARY	MB	MAIL BOX	RT	RIGHT	T-A	TYPE A
CL-F	CENTERLINE TO FACE	FAUS	FEDERAL AID URBAN SECONDARY	MH	MANHOLE	ROW	RIGHT-OF-WAY	TYP	TYPICAL
CTS	CENTERS	FP	FENCE POST	MATL	MATERIAL	RD	ROAD	UNDGND	UNDERGROUND
CERT	CERTIFIED	OPT	FIBER OPTIC	MED	MEDIAN	RDWY	ROADWAY	USGS	U.S. GEOLOGICAL SURVEY
CHSLD	CHISELED	FE	FIELD ENTRANCE	m	METER	RTE	ROUTE	USEL	UPSTREAM ELEVATION
CS	CITY STREET	FH	FIRE HYDRANT	METH	METHOD	SAN	SANITARY	USFL	UPSTREAM FLOWLINE
CP	CLAY PIPE	FL	FLOW LINE	M	MID-ORDINATE	SANS	SANITARY SEWER	UTIL	UTILITY
CLSD	CLOSED	FB	FOOT BRIDGE	mm	MILLIMETER	SEC	SECTION	VBOX	VALVE BOX
CLID	CLOSED LID	FDN	FOUNDATION	mm DIA	MILLIMETER DIAMETER	SEED	SEEDING	VV	VALVE VAULT
CT	COAT OR COURT	FR	FRAME	MIX	MIXTURE	SHAP	SHAPING	VL	VAULT
COMB	COMBINATION	F&G	FRAME & GRATE	MBH	MOBILE HOME	S	SHED	VEH	VEHICLE
C	COMMERCIAL BUILDING	FRWAY	FREEWAY	MOD	MODIFIED	SH	SHEET	VP	VENT PIPE
CE	COMMERCIAL ENTRANCE	GAL	GALLON	MFT	MOTOR FUEL TAX	SHLD	SHOULDER	VERT	VERTICAL
CONC	CONCRETE	GALV	GALVANIZED	N & BC	NAIL & BOTTLE CAP	SW	SIDEWALK OR SOUTHWEST	VC	VERTICAL CURVE
CONST	CONSTRUCT	G	GARAGE	N & C	NAIL & CAP	SIG	SIGNAL	VPC	VERTICAL POINT OF CURVATURE
CONTD	CONTINUED	GM	GAS METER	N & W	NAIL & WASHER	SOD	SODDING	VPI	VERTICAL POINT OF INTERSECTION
CONT	CONTINUOUS	GV	GAS VALVE	NC	NORMAL CROWN	SM	SOLID MEDIUM	VPT	VERTICAL POINT OF TANGENCY
COR	CORNER	GIS	GEOGRAPHICAL INFORMATION SYSTEM	NB	NORTHBOUND	SB	SOUTHBOUND	WM	WATER METER
CORR	CORRUGATED	GRAN	GRANULAR	NE	NORTHEAST	SE	SOUTHEAST	VV	WATER VALVE
CMP	CORRUGATED METAL PIPE	GR	GRATE	NW	NORTHWEST	SPL	SPECIAL	WMAIN	WATER MAIN
CNTY	COUNTY	GRVL	GRAVEL	O/S	OFFSET	SD	SPECIAL DITCH	WB	WESTBOUND
CH	COUNTY HIGHWAY	GND	GROUND	O&C	OIL AND CHIP	SQ FT	SQUARE FEET	WILDFL	WILDFLOWERS
CSE	COURSE	GUT	GUTTER	OLID	OPEN LID	m ²	SQUARE METER	W	WITH
XSECT	CROSS SECTION	GP	GUY POLE	PAT	PATTERN	mm ²	SQUARE MILLIMETER	WO	WITHOUT
m ³	CUBIC METER	GW	GUY WIRE	PVD	PAVED	SQ YD	SQUARE YARD		
mm ³	CUBIC MILLIMETER	HH	HANDHOLE	PVMT	PAVEMENT	STB	STABILIZED		

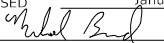
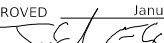
 Illinois Department of Transportation	
PASSED <u>January 1, 2021</u>  ENGINEER OF POLICY AND PROCEDURES	ISSUED 1-1-97
APPROVED <u>January 1, 2021</u>  ENGINEER OF DESIGN AND ENVIRONMENT	

DATE	REVISIONS
1-1-21	Updated fonts, abbreviations and symbols.
1-1-19	Added new symbols.

STANDARD SYMBOLS, ABBREVIATIONS AND PATTERNS

(Sheet 1 of 9)

STANDARD 000001-08

<u>ADJUSTMENT ITEMS</u>		<u>EX</u>	<u>PR</u>	<u>ALIGNMENT ITEMS</u>		<u>EX</u>	<u>PR</u>	<u>DRAINAGE ITEMS</u>		<u>EX</u>	<u>PR</u>
Structure To Be Adjusted			ADJ	Baseline	_____	_____		Channel or Stream Line	-----	-----	
Structure To Be Cleaned			C	Centerline	-----	-----		Culvert Line	-----	-----	
Main Structure To Be Filled			FM	Centerline Break Circle	○	⊙		Grading & Shaping Ditches	-----	-----	
Structure To Be Filled			F	Baseline Symbol	⊥	⊥		Drainage Boundary Line	////	////	
Structure To Be Filled Special			FSP	Centerline Symbol	⊥	⊥		Paved Ditch	-----	-----	
Structure To Be Removed			R	PI Indicator	△	△		Aggregate Ditch	-----	-----	
Structure To Be Reconstructed			REC	Point Indicator	○	○		Pipe Underdrain	-----	-----	
Structure To Be Reconstructed Special			RSP	Horizontal Curve Data (Half Size)	EX. CURVE P.I. STA= Δ= D= R= T= L= E= e= T.R.= S.E. RUN= P.C. STA= P.T. STA=	CURVE P.I. STA= Δ= D= R= T= L= E= e= T.R.= S.E. RUN= P.C. STA= P.T. STA=		Storm Sewer	-----	-----	
Frame and Grate To Be Adjusted			A	<u>BOUNDARIES ITEMS</u>		<u>EX</u>	<u>PR</u>	Flowline	⊥	⊥	
Frame and Lid To Be Adjusted			A	Dashed Property Line	-----	-----		Ditch Check	◆	◆	
Domestic Service Box To Be Adjusted			A	Solid Property/Lot Line	_____	_____		Headwall	-	∩	
Valve Vault To Be Adjusted			A	Section/Grant Line	-----	-----		Inlet	□	■	
Special Adjustment			SP	Quarter Section Line	-----	-----		Manhole	⊙	⊙	
Item To Be Abandoned			AB	Quarter/Quarter Section Line	-----	-----		Summit	↔	↔	
Item To Be Moved			M	County/Township Line	-----	-----		Roadway Ditch Flow	~→	~→	
Item To Be Relocated			REL	State Line	-----	-----		Swale	→	→	
Pavement Removal and Replacement				Chiseled Square Found	□	□		Catch Basin	○	●	
				Iron Pipe Found	○	●		Culvert End Section	◁	◁	
				Iron Pipe Set	●	●		Water Surface Indicator	▽	▽	
				Survey Marker	⊙	⊙		Riprap	▒	▒	
				Property Line Symbol	⊥	⊥		<u>HYDRAULICS ITEMS</u>		<u>EX</u>	<u>PR</u>
				Same Ownership Symbol (Half Size)	↗	↗		Overflow	↪	↪	
				Northwest Quarter Corner (Half Size)	⊙	⊙		Sheet Flow	→	→	
				Section Corner (Half Size)	⊙	⊙		Hydrant Outlet	→	→	
				Southeast Quarter Corner (Half Size)	⊙	⊙		STANDARD SYMBOLS, ABBREVIATIONS AND PATTERNS (Sheet 2 of 9) STANDARD 000001-08			

Illinois Department of Transportation
 PASSED January 1, 2021

 ENGINEER OF POLICY AND PROCEDURES
 APPROVED January 1, 2021

 ENGINEER OF DESIGN AND ENVIRONMENT

ISSUED 1-1-97

EROSION & SEDIMENT CONTROL ITEMS

EX

PR

- Cleaning & Grading Limits
- Dike
- Erosion Control Fence
- Perimeter Erosion Barrier
- Temporary Fence
- Ditch Check Temporary
- Ditch Check Permanent
- Inlet & Pipe Protection
- Sediment Basin
- Erosion Control Blanket
- Fabric Formed Concrete Revetment Mat
- Turf Reinforcement Mat
- Mulch Temporary
- Mulch Method 1
- Mulch Method 2 Stabilized
- Mulch Method 3 Hydraulic

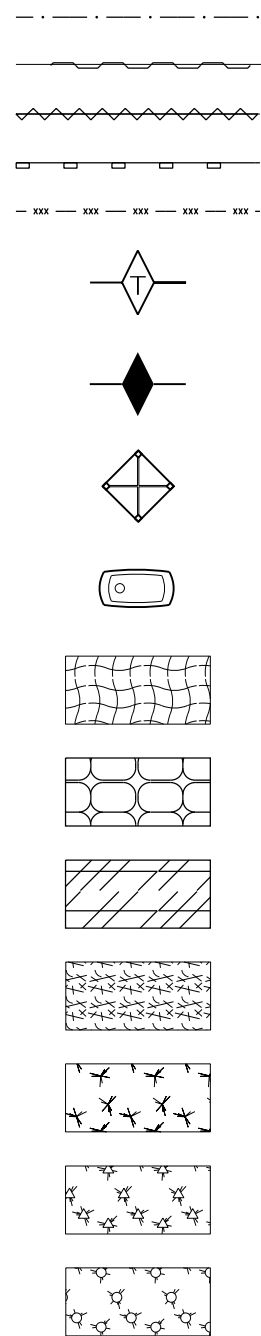

CONTOUR ITEMS

EX

PR

- Approx. Index Line
- Approx. Intermediate Line
- Index Contour
- Intermediate Contour

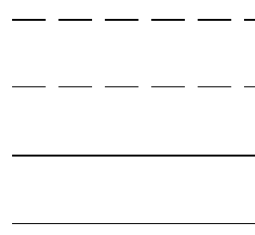

NON-HIGHWAY IMPROVEMENT ITEMS

EX

PR

- Noise Attn./Levee
- Field Line
- Fence
- Base of Levee
- Mailbox
- Multiple Mailboxes
- Pay Telephone
- Advertising Sign
- ITS* Camera
- Wind Turbine
- Cellular Tower

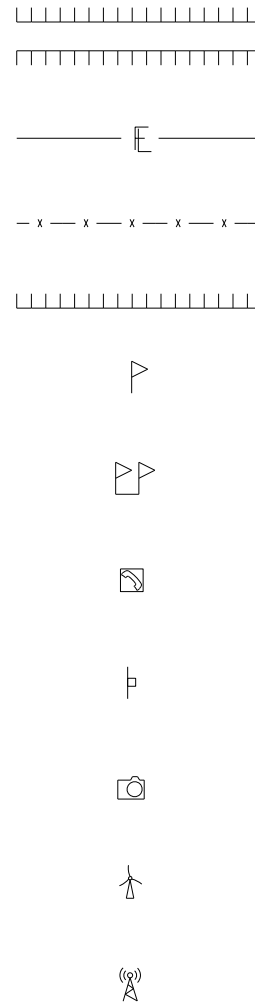

*Intelligent Transportation Systems

LANDSCAPING ITEMS

EX

PR

- Contour Mounding Line
- Fence
- Fence Post
- Shrubs
- Mowline
- Perennial Plants
- Seeding Class 2
- Seeding Class 2A
- Seeding Class 4
- Seeding Class 4 & 5 Combined

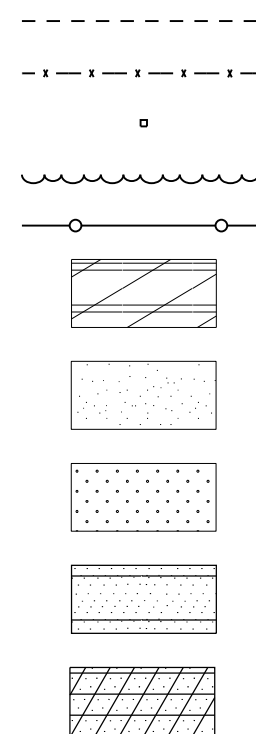

EXISTING LANDSCAPING ITEMS (contd.)

EX

PR

- Seeding Class 5
- Seeding Class 7
- Seedlings Type 1
- Seedlings Type 2
- Sodding
- Mowstake w/Sign
- Tree Trunk Protection
- Evergreen Tree
- Shade Tree

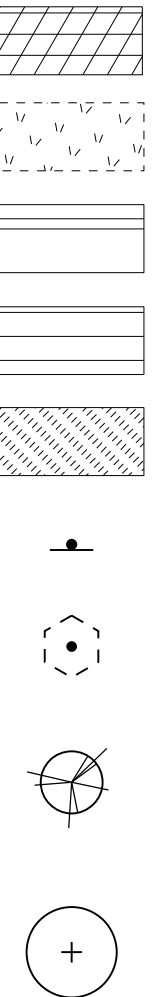

LIGHTING

EX

PR

- Duct
- Conduit
- Electrical Aerial Cable
- Electrical Buried Cable
- Controller
- Underpass Luminaire
- Power Pole

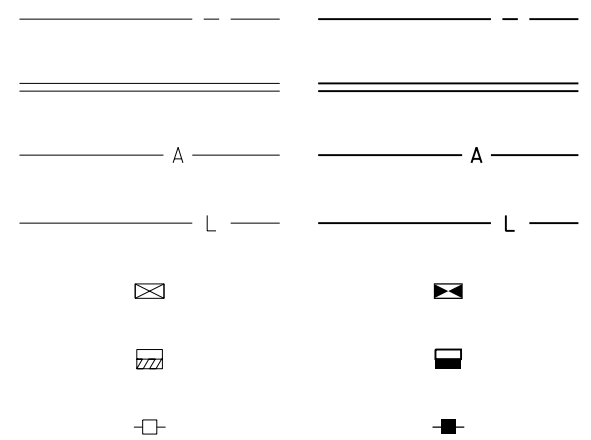

STANDARD SYMBOLS, ABBREVIATIONS AND PATTERNS

(Sheet 3 of 9)

STANDARD 000001-08

Illinois Department of Transportation

PASSED January 1, 2021
Michael Bond
 ENGINEER OF POLICY AND PROCEDURES

APPROVED January 1, 2021
Joe E. Cole
 ENGINEER OF DESIGN AND ENVIRONMENT

ISSUED 1-1-97

**LIGHTING
(contd.)**

EX

PR

Pull Point



Handhole



Heavy Duty Handhole



Junction Box



Light Unit Comb.



Electrical Ground



Traffic Flow Arrow



High Mast Pole
(Half Size)



Light Unit-1



PAVEMENT (MISC.)

EX

PR

Keyed Long. Joint

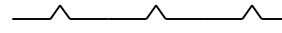

Keyed Long. Joint w/Tie Bars

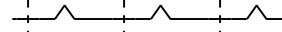

Sawed Long. Joint w/Tie Bars

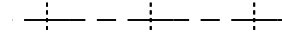

Bituminous Shoulder



Bituminous Taper



Stabilized Driveway

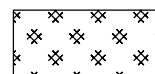

Widening



PAVEMENT MARKINGS

EX

PR

Handicap Symbol



RR Crossing

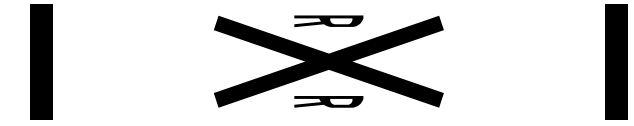
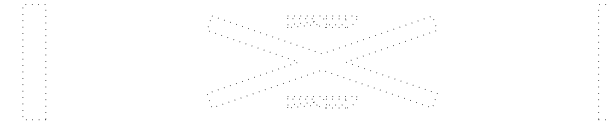

Raised Marker Amber 1 Way



Raised Marker Amber 2 Way



Raised Marker Crystal 1 Way



Two Way Turn Left



Shoulder Diag. Pattern

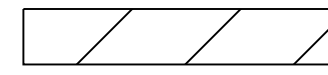

Skip-Dash White



Skip-Dash Yellow

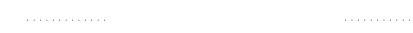

Stop Line

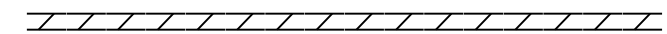

Solid Line

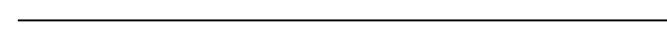

Double Centerline

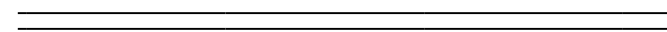

Dotted Lines

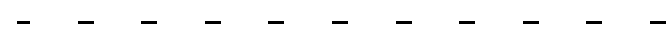
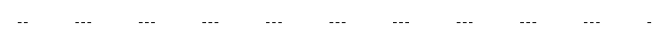

Illinois Department of Transportation

PASSED January 1, 2021
Michael Bond
 ENGINEER OF POLICY AND PROCEDURES

APPROVED January 1, 2021
Joe E. Cole
 ENGINEER OF DESIGN AND ENVIRONMENT

ISSUED 1-1-97

**STANDARD SYMBOLS,
ABBREVIATIONS
AND PATTERNS**

(Sheet 4 of 9)

STANDARD 000001-08

PAVEMENT MARKINGS
(contd.)

CL 2Ln 2Way
RRPM 12.2 m (40') o.c.

CL 2Ln 2Way
RRPM 80' (24.4 m) o.c.

CL Multilane Div.
RRPM 40' (12.2 m) o.c.

CL Multilane Div.
RRPM 80' (24.4 m) o.c.

CL Multilane Div. Dbl.
RRPM 80' (24.4 m) o.c.

CL Multilane Undiv.

Two Way Turn Left Line

Urban Combination Left

Urban Combination Right

Urban Left Turn Arrow

Urban Right Turn Arrow

Urban Left Turn Only

Urban Right Turn Only

Urban Thru Only

EX

PR

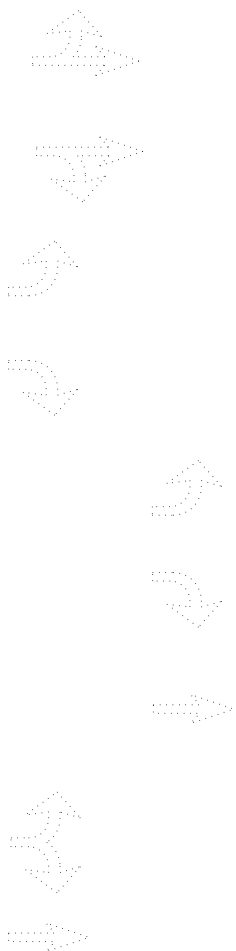
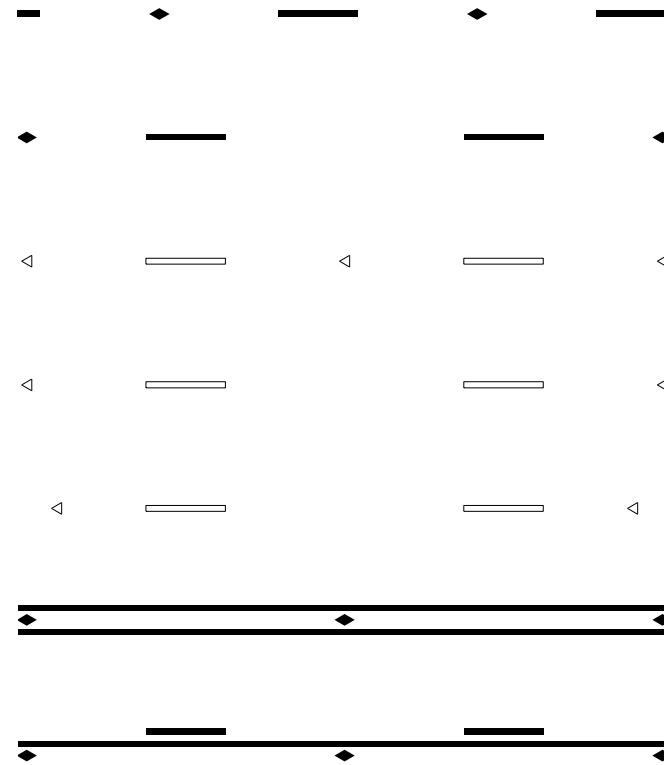

ONLY
ONLY
ONLY

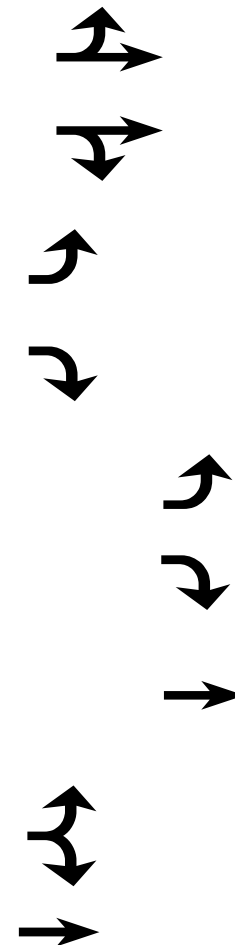

RAILROAD ITEMS

EX

PR

Abandoned Railroad

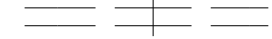

Railroad

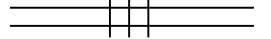
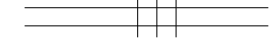

Railroad Point



Control Box



Crossing Gate



Flashing Signal



Railroad Cant. Mast Arm

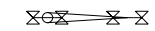

Crossbuck



REMOVAL ITEMS

EX

PR

Removal Tic

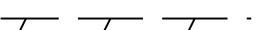

Bituminous Removal

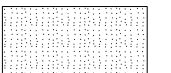

Hatch Pattern

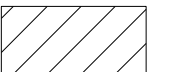

Tree Removal Single



RIGHT OF WAY ITEMS

EX

PR

Future ROW Corner Monument



ROW Marker



ROW Line

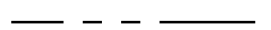

Easement

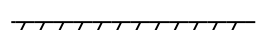

Temporary Easement

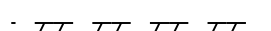

Illinois Department of Transportation

PASSED January 1, 2021
Michael Bond
ENGINEER OF POLICY AND PROCEDURES

APPROVED January 1, 2021
Scott Clark
ENGINEER OF DESIGN AND ENVIRONMENT

ISSUED 1-1-97

Urban LT & RT Turn Arrow

Urban Thru Arrow

**STANDARD SYMBOLS,
ABBREVIATIONS
AND PATTERNS**

(Sheet 5 of 9)

STANDARD 000001-08

PAVEMENT MARKINGS
(contd.)

EX

PR

Urban U-Turn



Urban Combined U-Turn



Rural Combination Left



Rural Combination Right



Rural Left Turn Arrow



Rural Right Turn Arrow



Rural Left Turn Only

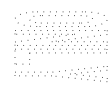

ONLY ONLY ONLY



Rural Right Turn Only



Rural Thru Only

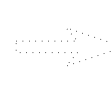
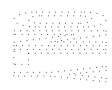

Rural Thru Arrow



Rural Lt & Rt Turn Arrow



Bike Lane Symbol

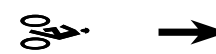

Bike Lane Text



Bike Path Shared



Bike Shared Roadway



Lane Drop Symbol



Wrong Way Arrow

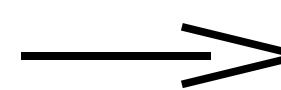

Illinois Department of Transportation

PASSED January 1, 2021
Michael Bond
ENGINEER OF POLICY AND PROCEDURES

APPROVED January 1, 2021
Joe E. Cline
ENGINEER OF DESIGN AND ENVIRONMENT

ISSUED 1-1-97

**STANDARD SYMBOLS,
ABBREVIATIONS
AND PATTERNS**
(Sheet 6 of 9)

STANDARD 000001-08

RIGHT OF WAY ITEMS
(contd.)

	EX	PR
Access Control Line	—	— AC —
Access Control Line & ROW	— AC —	— AC —
Access Control Line & ROW with Fence	— x — AC —	— x — AC — x —
Excess ROW Line		— XS —

ROADWAY PLAN
ITEMS

	EX	PR
Cable Barrier		
Concrete Barrier		
Edge of Pavement	---	---
Bit Shoulders, Medians and C&G Line	---	---
Aggregate Shoulder	---	---
Sidewalks, Driveways	---	---
Guardrail		
Guardrail Post	□	
Traffic Sign	⊥	⊥
Corrugated Median		
Impact Attenuator		
North Arrow with District Office (Half Size)		
Match Line		STA. 45+00
Slope Limit Line	---	
Typical Cross-Section Line	---	---

ROADWAY PROFILES

	EX	PR
P.I. Indicator	△	△
Point Indicator	○	○
Earthworks Balance Point		
Begin Point		
Vert. Curve Data	VPI = ELEV = L = E =	VPI = ELEV = L = E =
Ditch Profile Left Side	-----	-----
Ditch Profile Right Side	-----	-----
Roadway Profile Line	-----	-----
Storm Sewer Profile Left Side	-----	-----
Storm Sewer Profile Right Side	-----	-----

SIGNING ITEMS

	EX	PR
Cone, Drum or Barricade		○
Barricade Type II		
Barricade Type III		TT
Barricade With Edge Line		
Flashing Light Sign		○
Panels I		
Panels II		
Direction of Traffic		➔
Sign Flag (Half Size)		◇

SIGNING ITEMS
(contd.)

	EX	PR
Reverse Left W1-4L (Half Size)		
Reverse Right W1-4R (Half Size)		
Two Way Traffic Sign W6-3 (Half Size)		
Detour Ahead W20-2(O) (Half Size)		
Left Lane Closed Ahead W20-5L(O) (Half Size)		
Right Lane Closed Ahead W20-5R(O) (Half Size)		
Road Closed Ahead W20-3(O) (Half Size)		
Road Construction Ahead W20-1(O) (Half Size)		
Single Lane Ahead (Half Size)		
Transition Left W4-2L (Half Size)		
Transition Right W4-2R (Half Size)		

Illinois Department of Transportation

PASSED January 1, 2021
Michael Bond
ENGINEER OF POLICY AND PROCEDURES

APPROVED January 1, 2021
Joe E. Cole
ENGINEER OF DESIGN AND ENVIRONMENT

ISSUED 1-1-97

**STANDARD SYMBOLS,
ABBREVIATIONS
AND PATTERNS**
(Sheet 7 of 9)

STANDARD 000001-08

SIGNING ITEMS
(contd.)

EX

PR

One Way Arrow Lrg. W1-6-(O)
(Half Size)

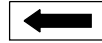

Two Way Arrow Large W1-7-(O)
(Half Size)

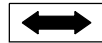

Detour M4-10L-(O)
(Half Size)



Detour M4-10R-(O)
(Half Size)



One Way Left R6-1L
(Half Size)



One Way Right R6-1R
(Half Size)



Left Turn Lane R3-I100L
(Half Size)



Keep Left R4-7AL
(Half Size)



Keep Left R4-7BL
(Half Size)



Keep Right R4-7AR
(Half Size)



Keep Right R4-7BR
(Half Size)



Stop Here On Red R10-6-AL
(Half Size)



Stop Here On Red R10-6-AR
(Half Size)



No Left Turn R3-2
(Half Size)



No Right Turn R3-1
(Half Size)



Road Closed R11-2
(Half Size)

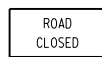

Road Closed Thru Traffic R11-2
(Half Size)

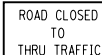

STRUCTURES ITEMS

EX

PR

Box Culvert Barrel

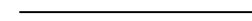

Box Culvert Headwall



Bridge Pier



Bridge



Retaining Wall

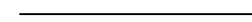

Temporary Sheet Piling



TRAFFIC SHEET
ITEMS

EX

PR

Cable Number



Left Turn Green



Left Turn Yellow



Signal Backplate

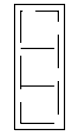

Signal Section 8" (200 mm)



Signal Section 12" (300 mm)



Walk/Don't Walk Letters



Walk/Don't Walk Symbols



TRAFFIC SIGNAL
ITEMS

EX

PR

Galv. Steel Conduit



Underground Cable

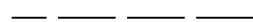

Detector Loop Line



Detector Loop Large



Detector Loop Small



Detector Loop Quadrapole



STANDARD SYMBOLS,
ABBREVIATIONS
AND PATTERNS

(Sheet 8 of 9)

STANDARD 000001-08

Illinois Department of Transportation

PASSED January 1, 2021
Michael Bond
ENGINEER OF POLICY AND PROCEDURES

APPROVED January 1, 2021
Joe E. Cole
ENGINEER OF DESIGN AND ENVIRONMENT

ISSUED 1-1-97

TRAFFIC SIGNAL ITEMS (contd.)

EX

PR

Detector Raceway



Aluminum Mast Arm



Steel Mast Arm



Veh. Detector Magnetic



Conduit Splice



Controller



Gulfbox Junction



Wood Pole



Temp. Signal Head



Handhole



Double Handhole



Heavy Duty Handhole



Junction Box



Ped. Pushbutton Detector



Ped. Signal Head



Power Pole Service



Priority Veh. Detector



Signal Head



Signal Head w/Backplate



Signal Post



Closed Circuit TV



Video Detector System



UNDERGROUND UTILITY ITEMS

EX

PR

ABANDONED

Cable TV

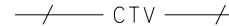

Electric Cable

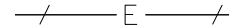
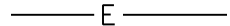

Fiber Optic



Gas Pipe

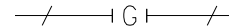

Oil Pipe



Sanitary Sewer

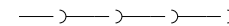
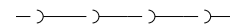

Telephone Cable

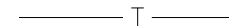
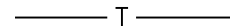

Water Pipe

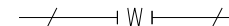
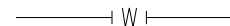

UTILITIES ITEMS

EX

PR

Controller



Double Handhole



Fire Hydrant



GuyWire or Deadman Anchor



Handhole



Heavy Duty Handhole



Junction Box



Light Pole



Manhole



Monitoring Well (Gasoline)



Pipeline Warning Sign



Power Pole



Power Pole with Light



Sanitary Sewer Cleanout



Splice Box Above Ground



Telephone Splice Box Above Ground



Telephone Pole



UTILITY ITEMS (contd.)

EX

PR

Traffic Signal



Traffic Signal Control Box



Water Meter



Water Meter Valve Box



Profile Line



Aerial Power Line



VEGETATION ITEMS

EX

PR

Deciduous Tree



Bush or Shrub



Evergreen Tree



Stump



Orchard/Nursery Line

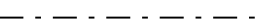

Vegetation Line



Woods & Bush Line



WATER FEATURE ITEMS

EX

PR

Stream or Drainage Ditch

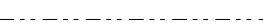

Waters Edge

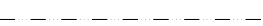

Water Surface Indicator



Water Point



Disappearing Ditch



Marsh



Marsh/Swamp Boundary



STANDARD SYMBOLS, ABBREVIATIONS AND PATTERNS

(Sheet 9 of 9)

STANDARD 000001-08

Illinois Department of Transportation

PASSED January 1, 2021

APPROVED January 1, 2021

ISSUED 1-1-97

ENGINEER OF POLICY AND PROCEDURES

ENGINEER OF DESIGN AND ENVIRONMENT

REINFORCEMENT BARS - ENGLISH (METRIC)																	
Bar Size	Dia. in. mm	Cross-Sectional Area sq. in. (sq. mm)	Weight lbs./ft. kg/m	SPACING, in. (mm)													
				4 (100)	4½ (115)	5 (125)	5½ (140)	6 (150)	6½ (165)	7 (175)	7½ (190)	8 (200)	8½ (215)	9 (225)	10 (250)	11 (275)	12 (300)
English (metric)				AREA OF STEEL PER FOOT (METER), sq. in. (sq. mm)													
3 (10)	0.375 (9.5)	0.110 (71)	0.376 (0.560)	0.330 (710)	0.293 (617)	0.264 (568)	0.240 (507)	0.220 (473)	0.203 (430)	0.189 (406)	0.176 (374)	0.165 (355)	0.155 (330)	0.147 (316)	0.132 (284)	0.120 (258)	0.110 (237)
4 (13)	0.500 (12.7)	0.196 (129)	0.668 (0.944)	0.588 (1290)	0.523 (1122)	0.470 (1032)	0.428 (921)	0.392 (860)	0.362 (782)	0.336 (737)	0.314 (679)	0.294 (645)	0.277 (600)	0.261 (573)	0.235 (516)	0.214 (469)	0.196 (430)
5 (16)	0.625 (15.9)	0.307 (199)	1.043 (1.552)	0.921 (1990)	0.819 (1730)	0.737 (1592)	0.670 (1421)	0.614 (1327)	0.567 (1206)	0.526 (1137)	0.491 (1047)	0.461 (995)	0.433 (926)	0.409 (884)	0.368 (796)	0.335 (724)	0.307 (663)
6 (19)	0.750 (19.1)	0.442 (284)	1.502 (2.235)	1.326 (2840)	1.179 (2470)	1.061 (2272)	0.964 (2029)	0.884 (1893)	0.816 (1721)	0.758 (1623)	0.707 (1495)	0.663 (1420)	0.624 (1321)	0.589 (1262)	0.530 (1136)	0.482 (1033)	0.442 (947)
7 (22)	0.875 (22.2)	0.601 (387)	2.044 (3.042)	1.803 (3870)	1.603 (3365)	1.442 (3096)	1.311 (2764)	1.202 (2580)	1.110 (2345)	1.030 (2211)	0.962 (2037)	0.902 (1935)	0.848 (1800)	0.801 (1720)	0.721 (1548)	0.656 (1407)	0.601 (1290)
8 (25)	1.000 (25.4)	0.785 (510)	2.670 (3.973)	2.355 (5100)	2.093 (4435)	1.884 (4080)	1.713 (3543)	1.570 (3400)	1.449 (3091)	1.346 (2914)	1.256 (2684)	1.178 (2550)	1.108 (2372)	1.047 (2267)	0.942 (2040)	0.856 (1855)	0.785 (1700)
9 (29)	1.128 (28.7)	1.000 (645)	3.400 (5.060)	3.000 (6450)	2.667 (5609)	2.400 (5160)	2.182 (4607)	2.000 (4300)	1.846 (3909)	1.714 (3686)	1.600 (3395)	1.500 (3225)	1.412 (3000)	1.333 (2867)	1.200 (2580)	1.091 (2345)	1.000 (2150)
10 (32)	1.270 (32.3)	1.267 (819)	4.303 (6.404)	3.801 (8190)	3.379 (7122)	3.041 (6552)	2.764 (5850)	2.534 (5460)	2.339 (4964)	2.172 (4680)	2.027 (4311)	1.901 (4095)	1.789 (3809)	1.689 (3640)	1.520 (3276)	1.382 (2978)	1.267 (2730)
11 (36)	1.410 (35.8)	1.561 (1006)	5.313 (7.907)	4.683 (10060)	4.163 (8748)	3.746 (8048)	3.406 (7186)	3.122 (6707)	2.882 (6097)	2.676 (5749)	2.498 (5295)	2.342 (5030)	2.204 (4679)	2.081 (4471)	1.873 (4024)	1.703 (3658)	1.561 (3353)

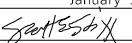
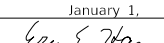
 Illinois Department of Transportation
 PASSED January 1, 2009

 ENGINEER OF POLICY AND PROCEDURES
 APPROVED January 1, 2009

 ENGINEER OF DESIGN AND ENVIRONMENT

ISSUED 1-1-97

DATE	REVISIONS
1-1-09	Switched units to English (metric).
1-1-07	Deleted metric table. Soft converted English table.

AREAS OF REINFORCEMENT BARS
STANDARD 001001-02

DECIMAL OF AN INCH AND OF A FOOT																	
A		B	A		B	A		B	A		B	A		B			
$\frac{1}{64}$	0.0052	$\frac{1}{16}$	$\frac{1}{64}$	0.171875	$2\frac{1}{16}$	$\frac{1}{32}$	0.3385	$4\frac{1}{16}$	$\frac{3}{64}$	0.5052	$6\frac{1}{16}$	$\frac{4}{64}$	0.671875	$8\frac{1}{16}$	$\frac{27}{32}$	0.8385	$10\frac{1}{16}$
	0.0104	$\frac{1}{8}$		0.1771	$2\frac{1}{8}$		0.34375	$4\frac{1}{8}$		0.5104	$6\frac{1}{8}$		0.6771	$8\frac{1}{8}$		0.84375	$10\frac{1}{8}$
	0.015625	$\frac{3}{16}$		0.1823	$2\frac{3}{16}$		0.3490	$4\frac{3}{16}$		0.515625	$6\frac{3}{16}$		0.6823	$8\frac{3}{16}$		0.8490	$10\frac{3}{16}$
	0.0208	$\frac{1}{4}$		0.1875	$2\frac{1}{4}$		0.3542	$4\frac{1}{4}$		0.5208	$6\frac{1}{4}$		0.6875	$8\frac{1}{4}$		0.8542	$10\frac{1}{4}$
$\frac{1}{32}$	0.0260	$\frac{5}{16}$	$\frac{1}{32}$	0.1927	$2\frac{5}{16}$	$\frac{2}{64}$	0.359375	$4\frac{5}{16}$	$\frac{17}{32}$	0.5260	$6\frac{5}{16}$	$\frac{45}{64}$	0.6927	$8\frac{5}{16}$	$\frac{55}{64}$	0.859375	$10\frac{5}{16}$
	0.03125	$\frac{3}{8}$		0.1979	$2\frac{3}{8}$		0.3646	$4\frac{3}{8}$		0.53125	$6\frac{3}{8}$		0.6979	$8\frac{3}{8}$		0.8646	$10\frac{3}{8}$
	0.0365	$\frac{7}{16}$		0.203125	$2\frac{7}{16}$		0.3698	$4\frac{7}{16}$		0.5365	$6\frac{7}{16}$		0.703125	$8\frac{7}{16}$		0.8698	$10\frac{7}{16}$
	0.0417	$\frac{1}{2}$		0.2083	$2\frac{1}{2}$		0.3750	$4\frac{1}{2}$		0.5417	$6\frac{1}{2}$		0.7083	$8\frac{1}{2}$		0.8750	$10\frac{1}{2}$
$\frac{3}{64}$	0.046875	$\frac{9}{16}$	$\frac{1}{32}$	0.2135	$2\frac{9}{16}$	$\frac{25}{64}$	0.3802	$4\frac{9}{16}$	$\frac{35}{64}$	0.546875	$6\frac{9}{16}$	$\frac{23}{32}$	0.7135	$8\frac{9}{16}$	$\frac{57}{64}$	0.8802	$10\frac{9}{16}$
	0.0521	$\frac{3}{8}$		0.21875	$2\frac{3}{8}$		0.3854	$4\frac{3}{8}$		0.5521	$6\frac{3}{8}$		0.71875	$8\frac{3}{8}$		0.8854	$10\frac{3}{8}$
	0.0573	$\frac{11}{16}$		0.2240	$2\frac{11}{16}$		0.390625	$4\frac{11}{16}$		0.5573	$6\frac{11}{16}$		0.7240	$8\frac{11}{16}$		0.890625	$10\frac{11}{16}$
	0.0625	$\frac{3}{4}$		0.2292	$2\frac{3}{4}$		0.3958	$4\frac{3}{4}$		0.5625	$6\frac{3}{4}$		0.7292	$8\frac{3}{4}$		0.8958	$10\frac{3}{4}$
$\frac{1}{16}$	0.0677	$\frac{13}{16}$	$\frac{1}{64}$	0.234375	$2\frac{13}{16}$	$\frac{13}{32}$	0.4010	$4\frac{13}{16}$	$\frac{9}{16}$	0.5677	$6\frac{13}{16}$	$\frac{47}{64}$	0.734375	$8\frac{13}{16}$	$\frac{29}{32}$	0.9010	$10\frac{13}{16}$
	0.0729	$\frac{7}{8}$		0.2396	$2\frac{7}{8}$		0.40625	$4\frac{7}{8}$		0.5729	$6\frac{7}{8}$		0.7396	$8\frac{7}{8}$		0.90625	$10\frac{7}{8}$
	0.078125	$\frac{15}{16}$		0.2448	$2\frac{15}{16}$		0.4115	$4\frac{15}{16}$		0.578125	$6\frac{15}{16}$		0.7448	$8\frac{15}{16}$		0.9115	$10\frac{15}{16}$
	0.0833	1		0.2500	3		0.4167	5		0.5833	7		0.7500	9		0.9167	11
$\frac{3}{32}$	0.0885	$\frac{17}{16}$	$\frac{1}{64}$	0.2552	$3\frac{17}{16}$	$\frac{27}{64}$	0.421875	$5\frac{17}{16}$	$\frac{19}{32}$	0.5885	$7\frac{17}{16}$	$\frac{49}{64}$	0.7552	$9\frac{17}{16}$	$\frac{59}{64}$	0.921875	$11\frac{17}{16}$
	0.09375	$\frac{1}{8}$		0.2604	$3\frac{1}{8}$		0.4271	$5\frac{1}{8}$		0.59375	$7\frac{1}{8}$		0.7604	$9\frac{1}{8}$		0.9271	$11\frac{1}{8}$
	0.0990	$\frac{3}{16}$		0.265625	$3\frac{3}{16}$		0.4323	$5\frac{3}{16}$		0.5990	$7\frac{3}{16}$		0.765625	$9\frac{3}{16}$		0.9323	$11\frac{3}{16}$
	0.1042	$\frac{1}{4}$		0.2708	$3\frac{1}{4}$		0.4375	$5\frac{1}{4}$		0.6042	$7\frac{1}{4}$		0.7708	$9\frac{1}{4}$		0.9375	$11\frac{1}{4}$
$\frac{7}{64}$	0.109375	$\frac{5}{16}$	$\frac{9}{32}$	0.2760	$3\frac{5}{16}$	$\frac{7}{16}$	0.4427	$5\frac{5}{16}$	$\frac{39}{64}$	0.609375	$7\frac{5}{16}$	$\frac{25}{32}$	0.7760	$9\frac{5}{16}$	$\frac{15}{16}$	0.9427	$11\frac{5}{16}$
	0.1146	$\frac{1}{8}$		0.28125	$3\frac{1}{8}$		0.4479	$5\frac{1}{8}$		0.6146	$7\frac{1}{8}$		0.78125	$9\frac{1}{8}$		0.9479	$11\frac{1}{8}$
	0.1198	$\frac{3}{16}$		0.2865	$3\frac{3}{16}$		0.453125	$5\frac{3}{16}$		0.6198	$7\frac{3}{16}$		0.7865	$9\frac{3}{16}$		0.953125	$11\frac{3}{16}$
	0.1250	$\frac{1}{2}$		0.2917	$3\frac{1}{2}$		0.4583	$5\frac{1}{2}$		0.6250	$7\frac{1}{2}$		0.7917	$9\frac{1}{2}$		0.9583	$11\frac{1}{2}$
$\frac{1}{8}$	0.1302	$\frac{19}{16}$	$\frac{1}{64}$	0.296875	$3\frac{19}{16}$	$\frac{29}{64}$	0.4635	$5\frac{19}{16}$	$\frac{5}{8}$	0.6302	$7\frac{19}{16}$	$\frac{51}{64}$	0.796875	$9\frac{19}{16}$	$\frac{61}{64}$	0.9635	$11\frac{19}{16}$
	0.1354	$\frac{1}{8}$		0.3021	$3\frac{1}{8}$		0.46875	$5\frac{1}{8}$		0.6354	$7\frac{1}{8}$		0.8021	$9\frac{1}{8}$		0.96875	$11\frac{1}{8}$
	0.140625	$\frac{3}{16}$		0.3073	$3\frac{3}{16}$		0.4740	$5\frac{3}{16}$		0.640625	$7\frac{3}{16}$		0.8073	$9\frac{3}{16}$		0.9740	$11\frac{3}{16}$
	0.1458	$\frac{1}{4}$		0.3125	$3\frac{1}{4}$		0.4792	$5\frac{1}{4}$		0.6458	$7\frac{1}{4}$		0.8125	$9\frac{1}{4}$		0.9792	$11\frac{1}{4}$
$\frac{5}{64}$	0.1510	$\frac{11}{16}$	$\frac{1}{32}$	0.3177	$3\frac{11}{16}$	$\frac{19}{32}$	0.484375	$5\frac{11}{16}$	$\frac{4}{64}$	0.6510	$7\frac{11}{16}$	$\frac{13}{16}$	0.8177	$9\frac{11}{16}$	$\frac{31}{32}$	0.984375	$11\frac{11}{16}$
	0.15625	$\frac{1}{8}$		0.3229	$3\frac{1}{8}$		0.4896	$5\frac{1}{8}$		0.65625	$7\frac{1}{8}$		0.8229	$9\frac{1}{8}$		0.9896	$11\frac{1}{8}$
	0.1615	$\frac{3}{16}$		0.328125	$3\frac{3}{16}$		0.4948	$5\frac{3}{16}$		0.6615	$7\frac{3}{16}$		0.828125	$9\frac{3}{16}$		0.9948	$11\frac{3}{16}$
	0.1667	2		0.3333	4		0.5000	6		0.6667	8		0.8333	10		0.9167	12

A = Fractions of Inch or Foot
 B = Inch Equivalents to Foot Fractions

DATE	REVISIONS
1-1-97	New Standard.

DECIMAL OF AN INCH AND OF A FOOT

STANDARD 001006

Illinois Department of Transportation

PASSED January 1, 1997

ENGINEER OF POLICY AND PROCEDURES

APPROVED January 1, 1997

ENGINEER OF DESIGN AND ENVIRONMENT

ISSUED 1-1-97

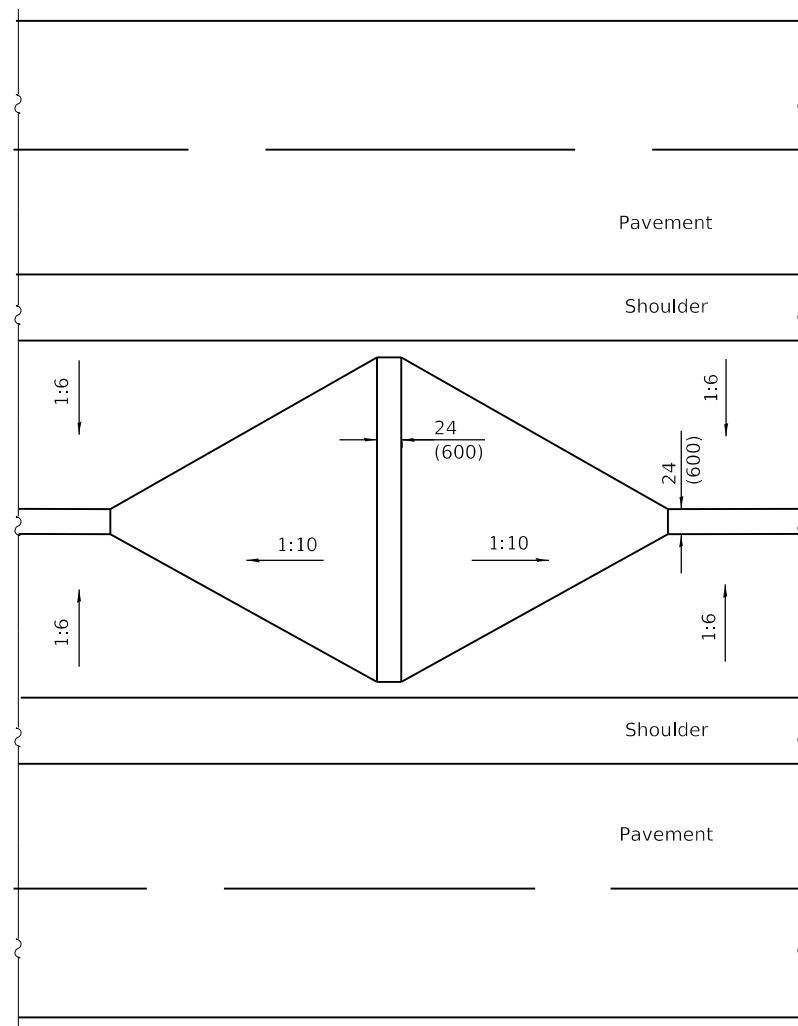

DITCH CHECK FOR NARROW MEDIAN

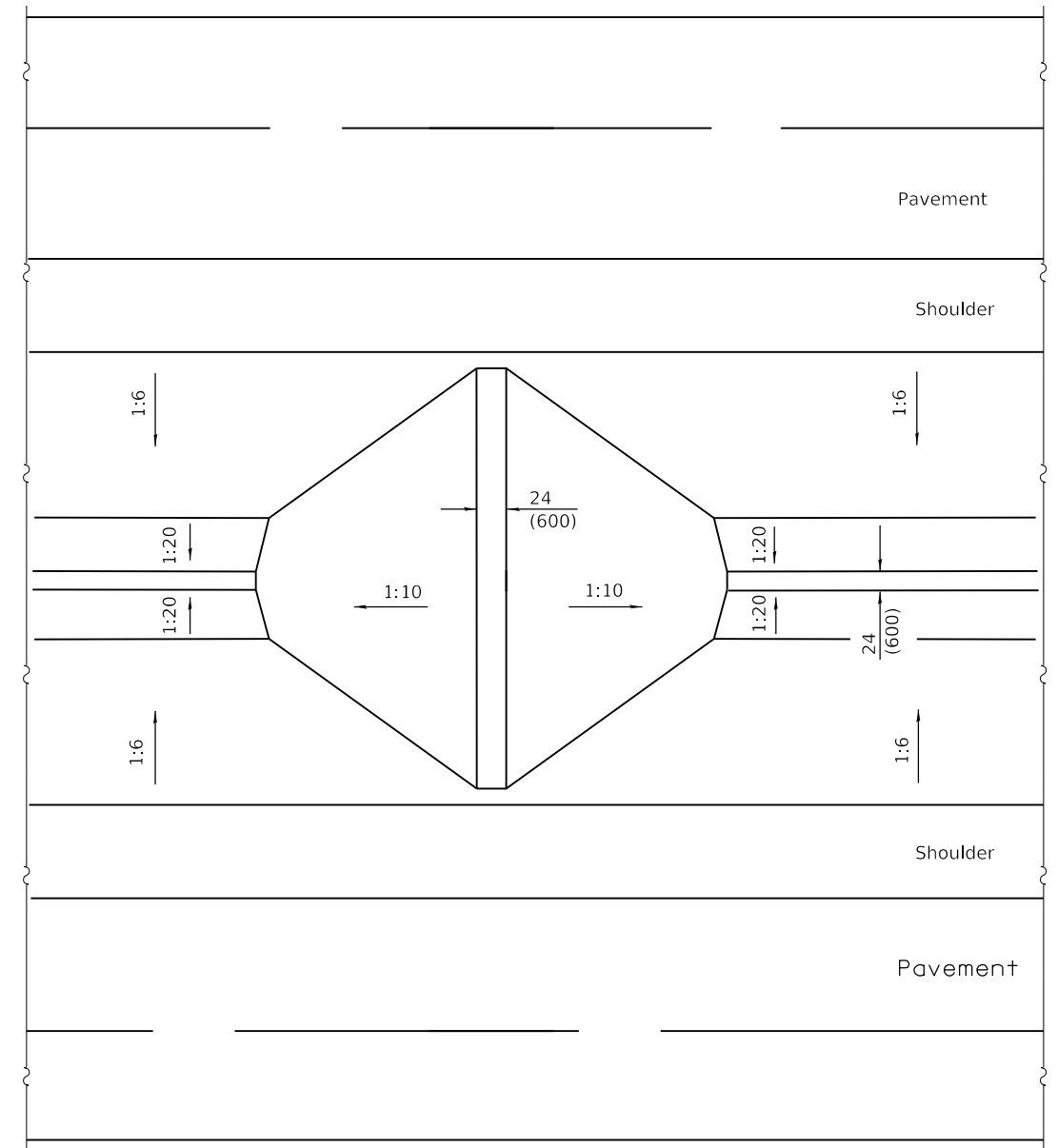

DITCH CHECK FOR WIDE MEDIAN

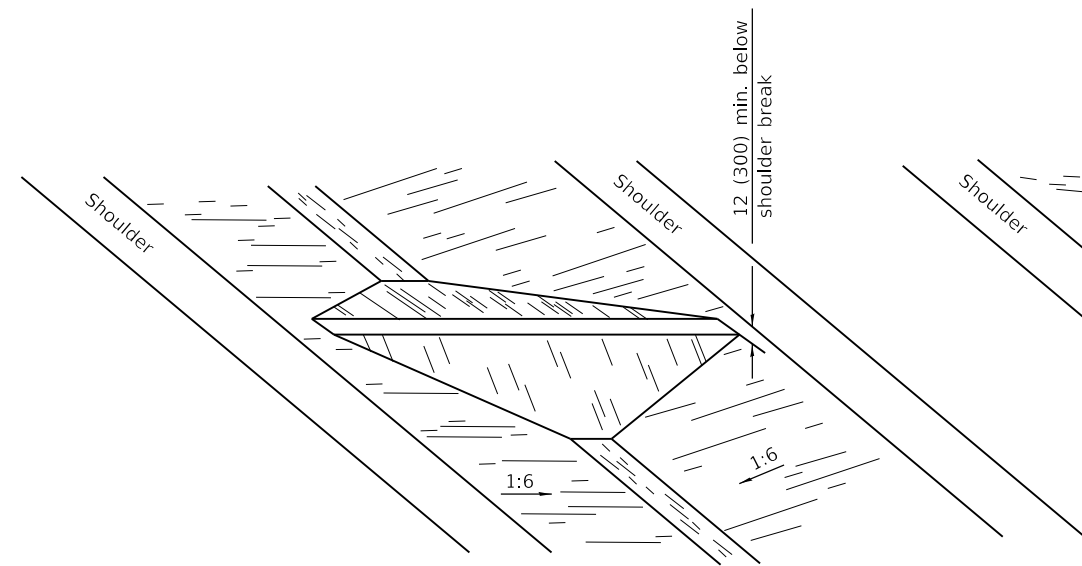

VIEW OF NARROW MEDIAN

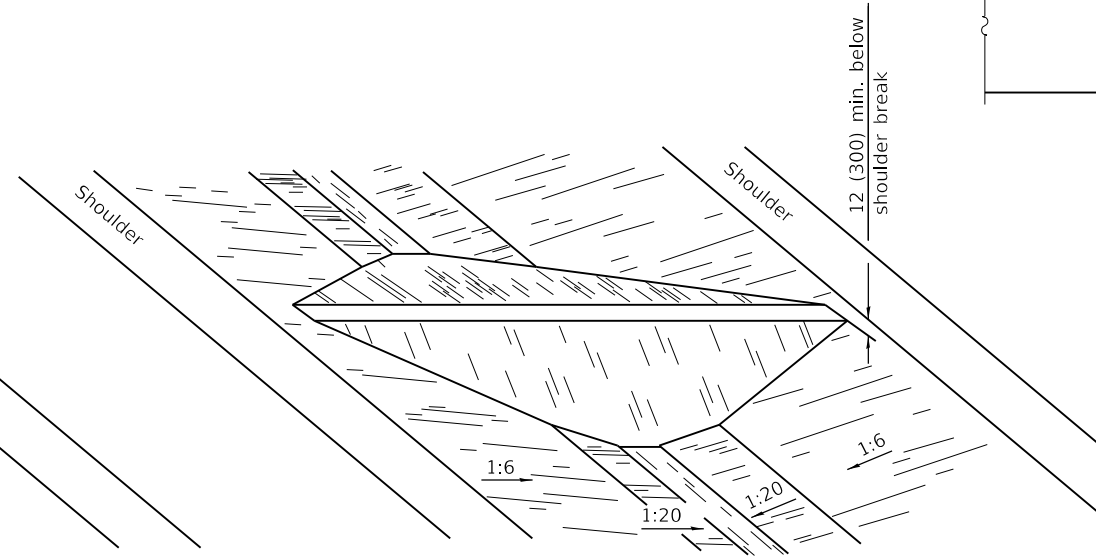

VIEW OF WIDE MEDIAN

GENERAL NOTES
 All slope ratios are expressed as units of vertical displacement to units of horizontal displacement (V:H).

All dimensions are in inches (millimeters) unless otherwise shown.

Illinois Department of Transportation

PASSED January 1, 2008
Scott Smith
 ENGINEER OF POLICY AND PROCEDURES

APPROVED January 1, 2008
Lee E. Han
 ENGINEER OF DESIGN AND ENVIRONMENT

ISSUED 1-1-97

DATE	REVISIONS
1-1-08	Switched units to English (metric).
1-1-97	Renum. Standard 2355-1.

**EARTH MEDIAN
 DITCH CHECK**

STANDARD 202001-01

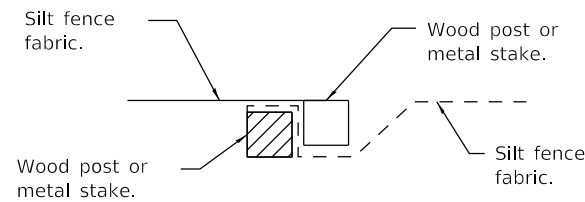

Place end-post (stake) of first silt fence adjacent to end-post (stake) of second silt fence with fabric positioned as shown.

STEP 1

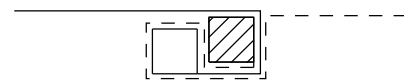

Rotate posts (stakes) together 180° clockwise and drive both posts (stakes) 18 (450) into ground.

STEP 2

ATTACHING TWO SILT FILTER FENCES

(Not applicable for J-hooks)

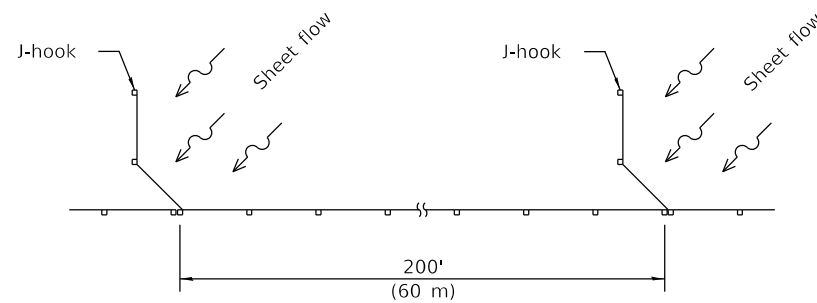

SILT FILTER J-HOOK PLACEMENT

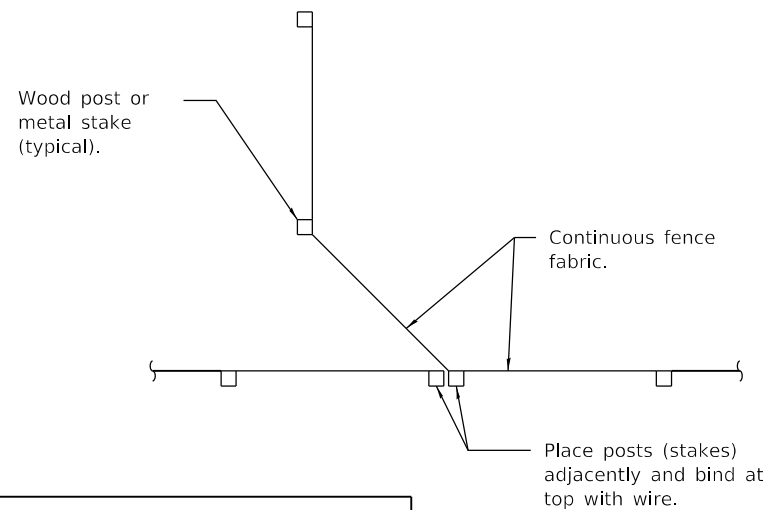

J-HOOK

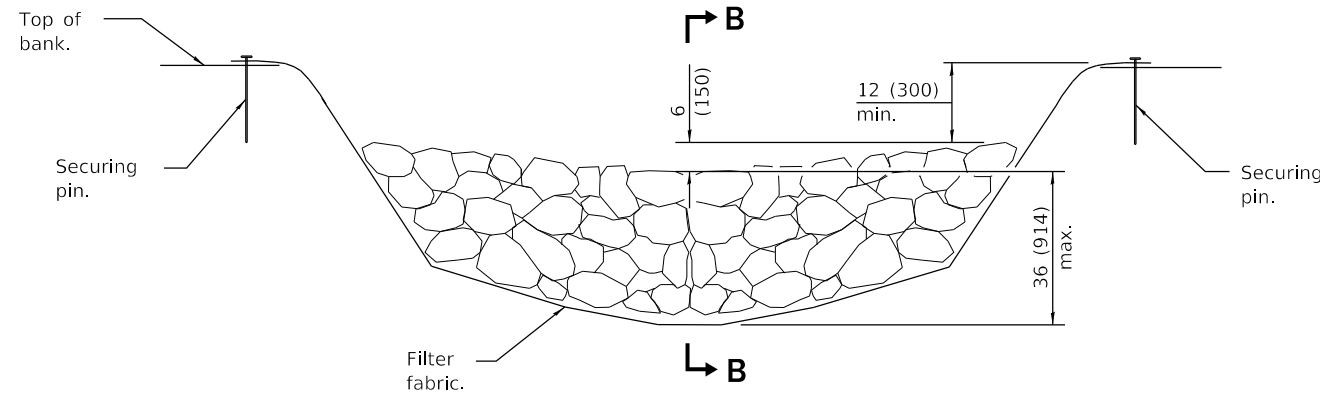

ELEVATION

* When the ditch check is within the clear zone and the road is open to traffic, the traffic approach slope of the aggregate shall be 1:4 (V:H).

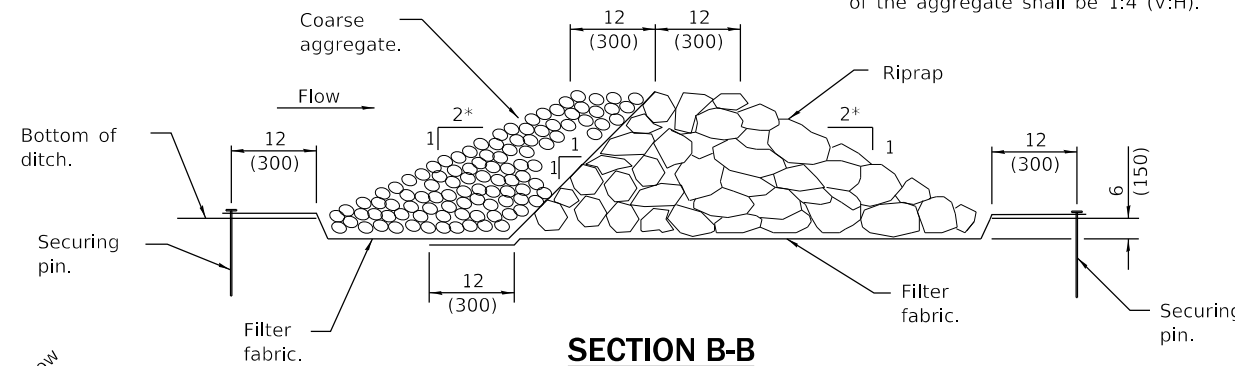

SECTION B-B

AGGREGATE DITCH CHECK

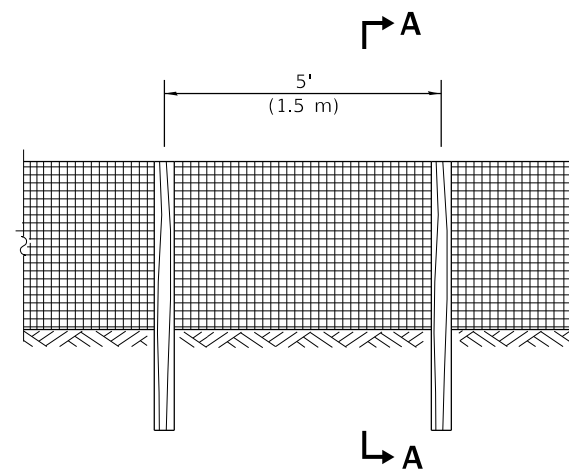

ELEVATION

SILT FILTER FENCE AS A PERIMETER EROSION BARRIER

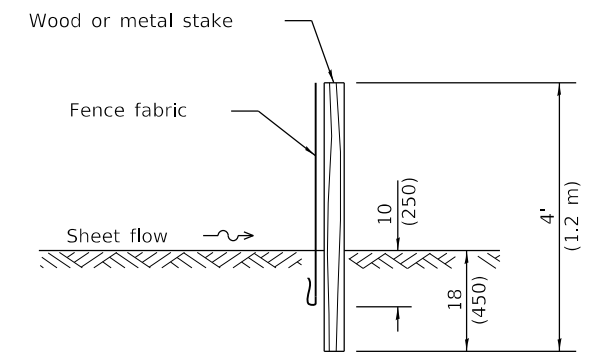

SLICE METHOD

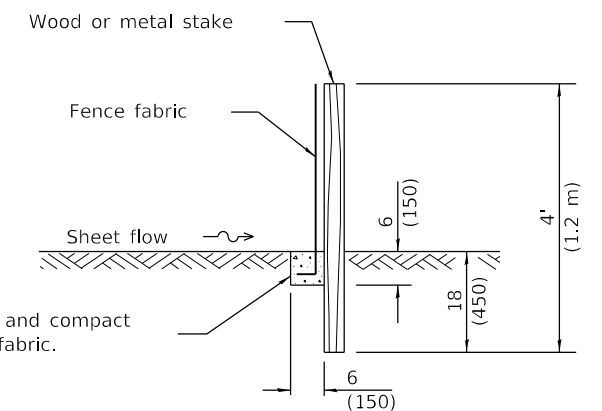

TRENCH METHOD

SECTION A-A

Excavate, backfill and compact trench to secure fabric.

GENERAL NOTES

The installation details and dimensions shown for perimeter erosion barriers shall also apply for inlet and pipe protection.

All dimensions are in inches (millimeters) unless otherwise shown.

Illinois Department of Transportation

PASSED January 1, 2013
Michael Beard
 ENGINEER OF POLICY AND PROCEDURES

APPROVED January 1, 2013
[Signature]
 ENGINEER OF DESIGN AND ENVIRONMENT

ISSUED 1-1-97

DATE	REVISIONS
1-1-13	Corrected notation for flowline (f _l) on SEDIMENT BASIN ELEVATION.
1-1-12	Omitted hay/straw perimeter barrier. Added SLICE METHOD to SECTION A-A.

TEMPORARY EROSION CONTROL SYSTEMS

(Sheet 1 of 2)

STANDARD 280001-07

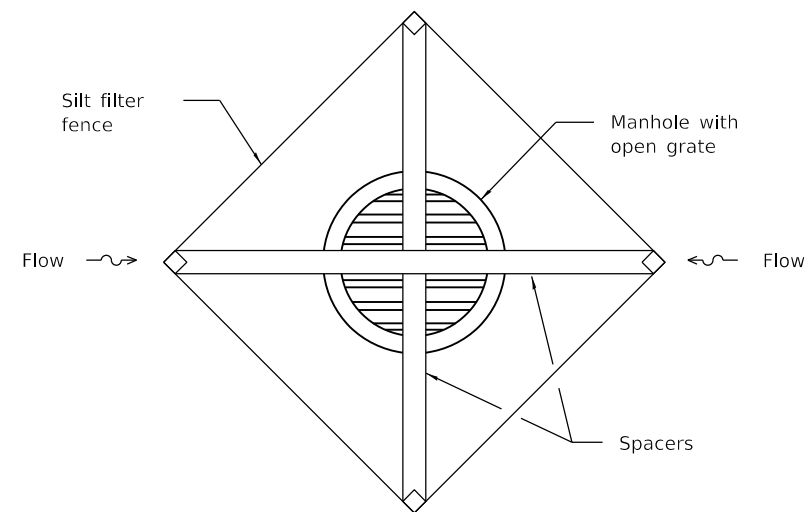
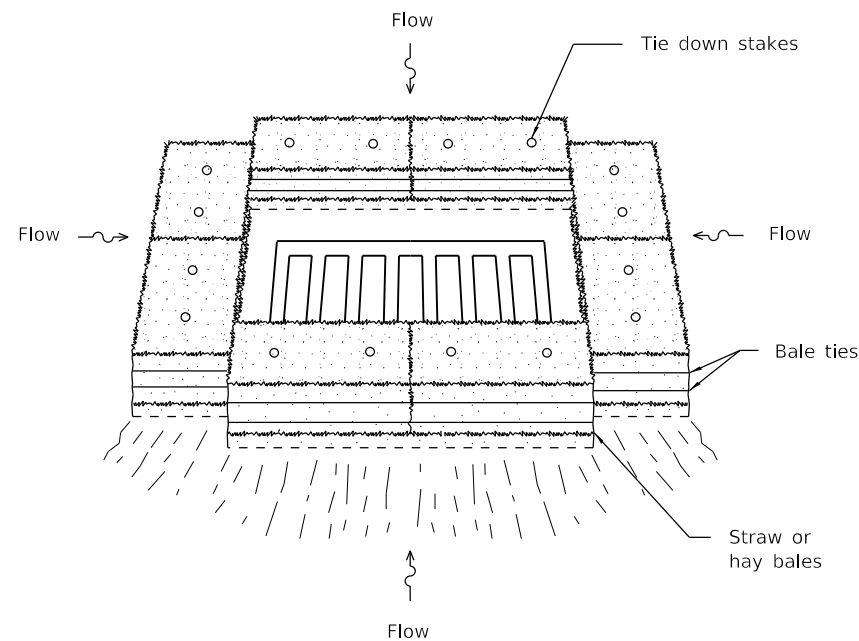
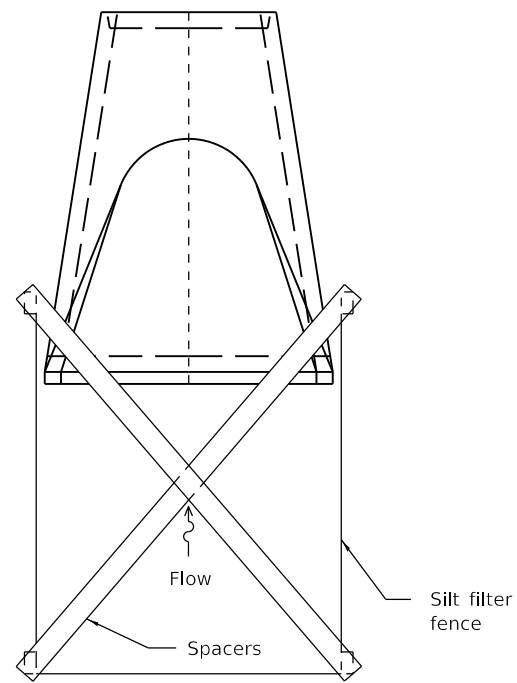
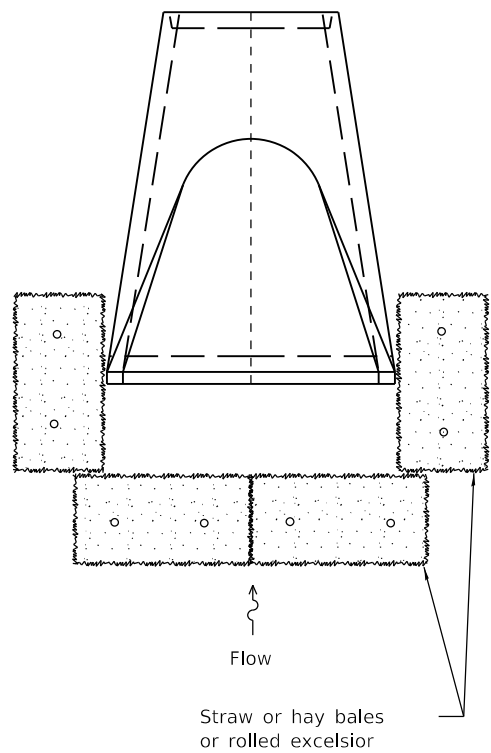

INLET AND PIPE PROTECTION

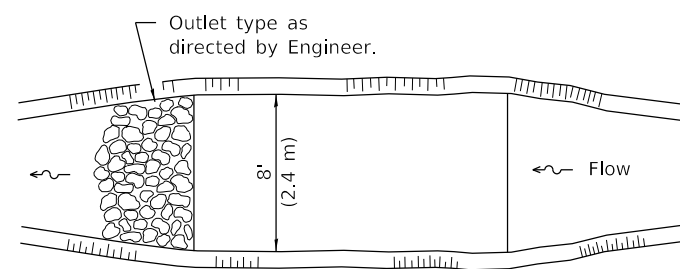
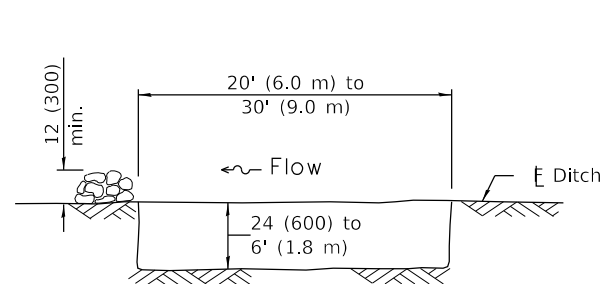

The performance of the basin will improve if put into a series.

The long dimension should be parallel with the direction of the flow. Accumulated silt shall be removed anytime the basins become 75% filled.

ELEVATION

PLAN

SEDIMENT BASIN

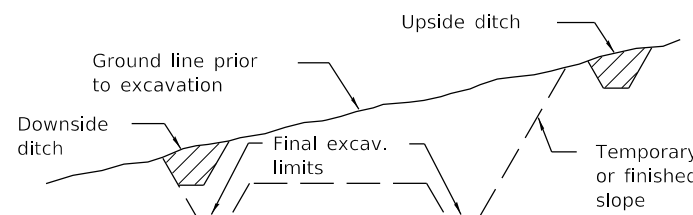

TYPICAL CUT CROSS-SECTION

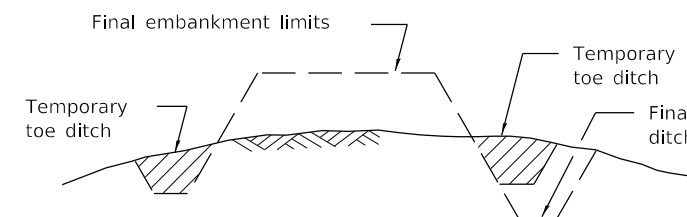

TYPICAL FILL CROSS-SECTION

TEMPORARY DITCHES FOR CUT & FILL SECTIONS

Illinois Department of Transportation

PASSED January 1, 2013
Michael Beard
 ENGINEER OF POLICY AND PROCEDURES

APPROVED January 1, 2013
[Signature]
 ENGINEER OF DESIGN AND ENVIRONMENT

ISSUED 1-1-97

TEMPORARY EROSION CONTROL SYSTEMS
 (Sheet 2 of 2)

STANDARD 280001-07

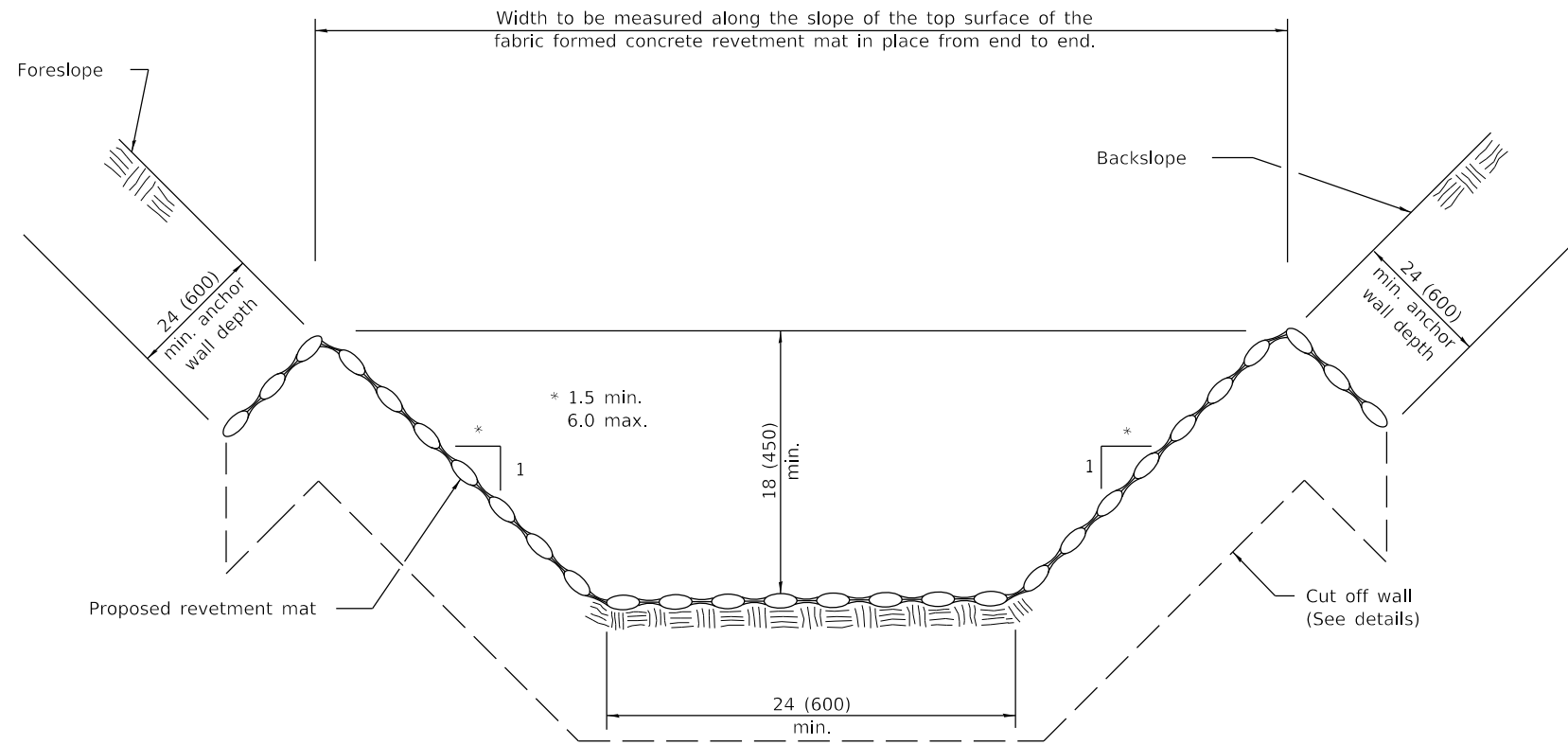

TYPICAL FABRIC FORMED CONCRETE REVETMENT MAT LINED DITCH

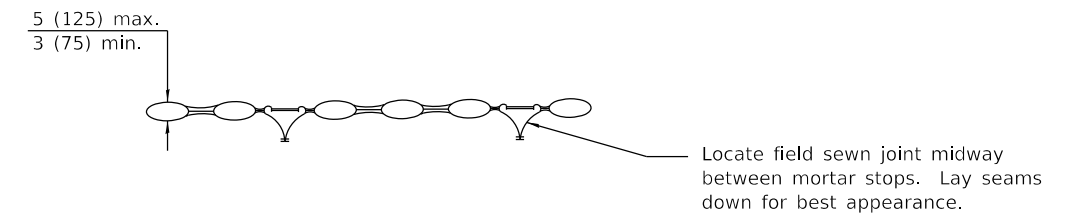

TYPICAL SECTION THRU FILTER POINT MAT

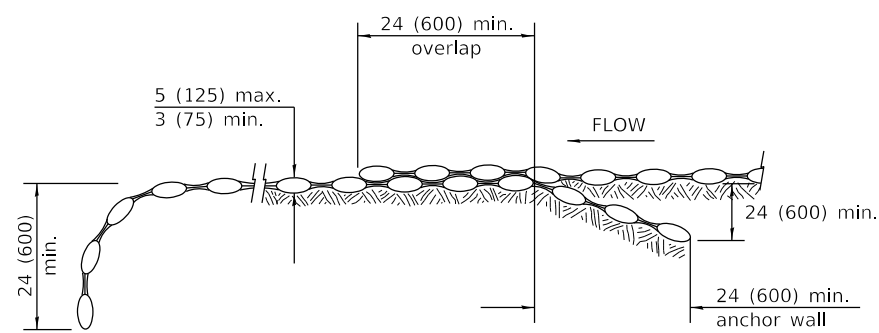

CUT OFF WALL DETAILS

TYPICAL LAP JOINTS W/ANCHOR WALL

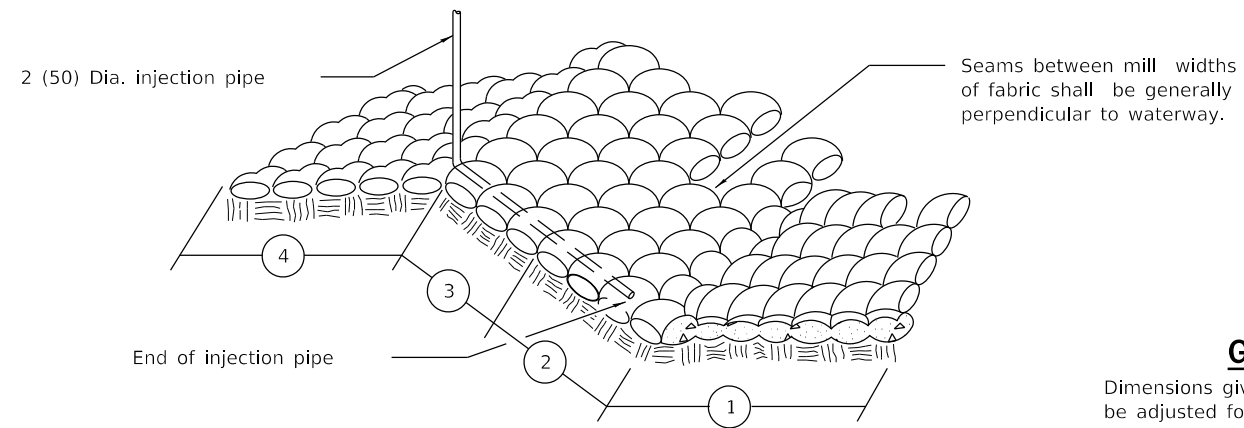

INSTALLATION DETAILS

1. In placing inserts through fabric use care to avoid breaking drop stitches.
2. ① Indicates sequence of pour.

GENERAL NOTES

Dimensions given with minimum limits shall be adjusted for field conditions as directed by the Engineer.

All anchor walls on side slopes and at lap joints, as well as cut off walls, shall be installed in trenches.

Cut off walls shall be installed at the upstream and downstream ends.

All dimensions are in inches (millimeters) unless otherwise shown.

Illinois Department of Transportation

PASSED January 1, 2008

ENGINEER OF POLICY AND PROCEDURES

APPROVED January 1, 2008

ENGINEER OF DESIGN AND ENVIRONMENT

ISSUED 1-1-97

DATE	REVISIONS
1-1-08	Switched units to English (metric).
1-1-02	Revised second note.

FABRIC FORMED CONCRETE REVETMENT MATS

STANDARD 285001-02

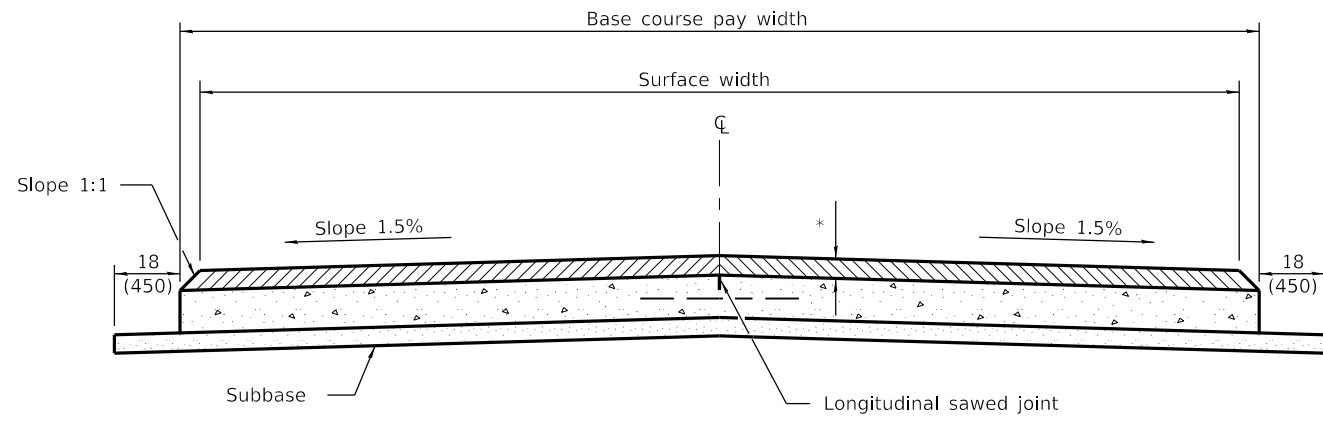

SECTION A-A
(TYPICAL 2 LANE WITH SHOULDERS)

* HMA binder and surface courses

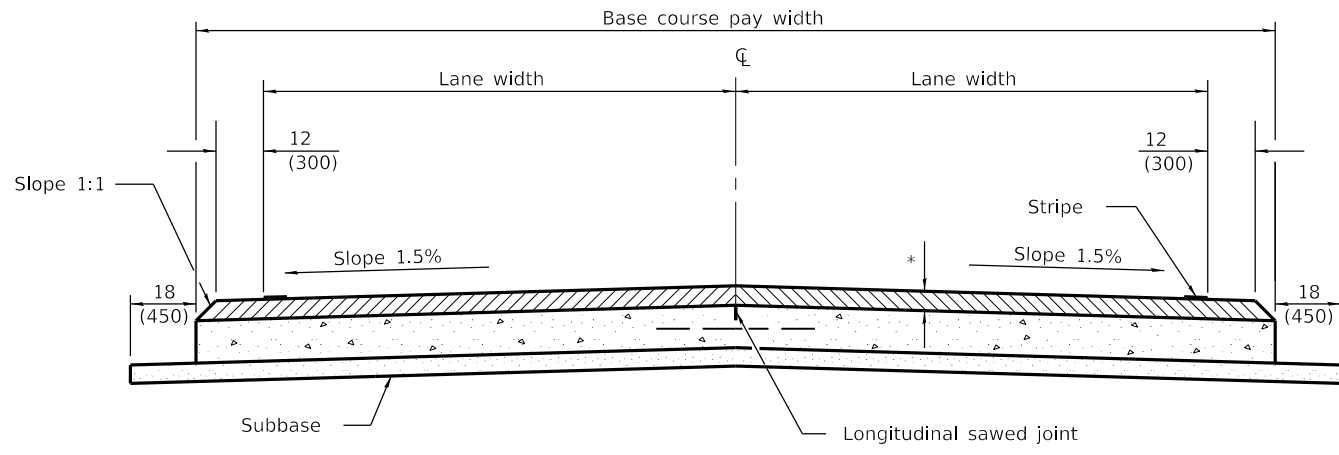

ALTERNATE SECTION A-A
(TYPICAL 2 LANE WITH SHOULDERS)

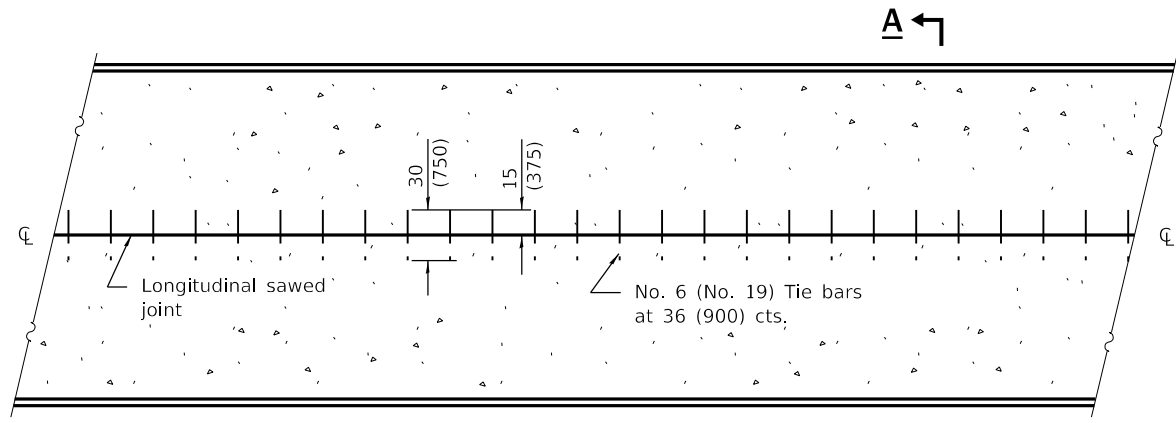

PLAN

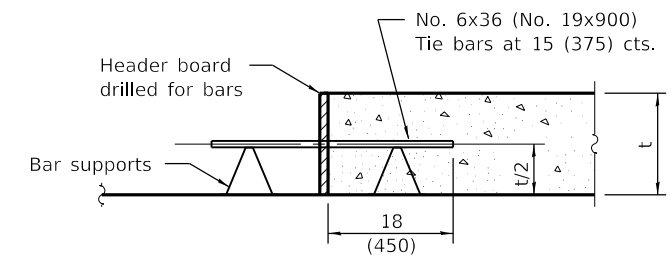

TRANSVERSE CONSTRUCTION JOINT

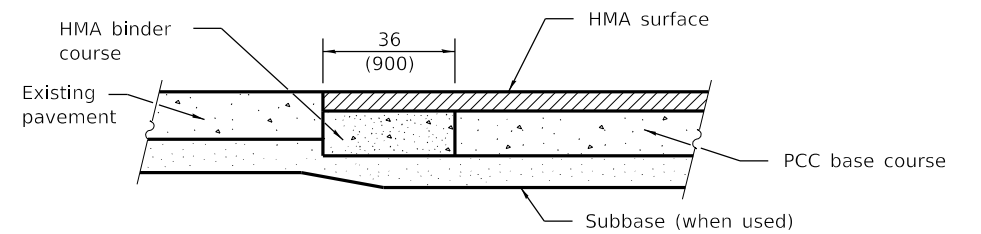

LONGITUDINAL SECTION SHOWING CONSTRUCTION ADJACENT TO EXISTING PAVEMENT

GENERAL NOTES

The longitudinal sawed joint shall be as detailed on Standard 420001 except the sawed groove does not require sealing.

All dimensions are in inches (millimeters) unless otherwise shown.

DATE	REVISIONS
1-1-18	Changed tie bar spacing to 36 (900) cts.
1-1-08	Switched units to English (metric).

PCC BASE COURSE WITH HMA BINDER AND SURFACE COURSES

STANDARD 353001-05

Illinois Department of Transportation

PASSED January 1, 2018
Michael Beard
 ENGINEER OF POLICY AND PROCEDURES

APPROVED January 1, 2018
Marcus M. Beck
 ENGINEER OF DESIGN AND ENVIRONMENT

ISSUED 1-1-97

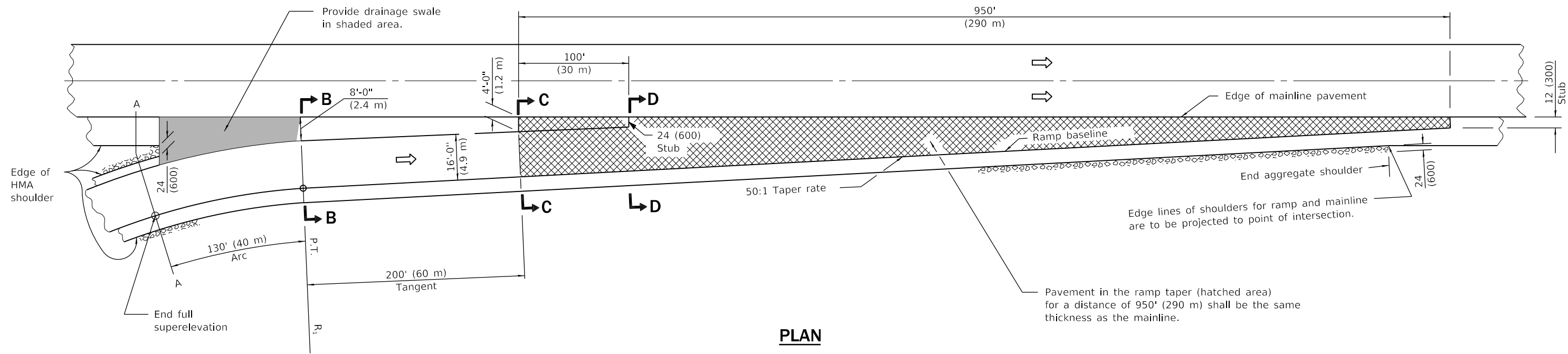

PLAN

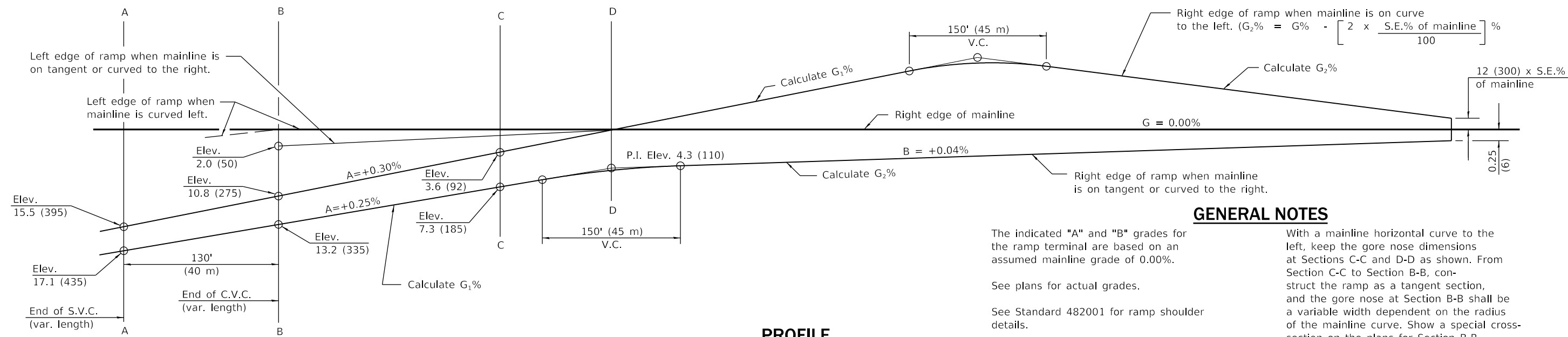

PROFILE

GENERAL NOTES

The indicated "A" and "B" grades for the ramp terminal are based on an assumed mainline grade of 0.00%.

See plans for actual grades.

See Standard 482001 for ramp shoulder details.

Between Sections A-A and B-B (shaded area), provide a drainage swale and flush inlet to enhance drainage.

When using grades expressed in %, the grade value shall be divided by 100 to obtain vertical offsets.

When using a radius R1 less than the minimum, verify the required acceleration length will be provided.

With a mainline horizontal curve to the left, keep the gore nose dimensions at Sections C-C and D-D as shown. From Section C-C to Section B-B, construct the ramp as a tangent section, and the gore nose at Section B-B shall be a variable width dependent on the radius of the mainline curve. Show a special cross-section on the plans for Section B-B.

With a mainline horizontal curve to the right, keep the gore nose dimensions at Sections D-D, C-C, and B-B as shown, and the edge of the ramp between Sections C-C and B-B shall be constructed as a compound curve tying Section C-C.

All dimensions are in inches (millimeters) unless otherwise shown.

Illinois Department of Transportation

PASSED January 1, 2015
Michael Beard
 ENGINEER OF POLICY AND PROCEDURES

APPROVED January 1, 2015
[Signature]
 ENGINEER OF DESIGN AND ENVIRONMENT

ISSUED 1-1-97

DATE	REVISIONS
1-1-15	Revised general note to be generic for R1.
1-1-08	Switched units to English (metric).
	Revised General Notes.

ENTRANCE RAMP TERMINAL
 (FLEXIBLE RAMP PAVEMENT ADJACENT TO FLEXIBLE MAINLINE PAVEMENT)

(Sheet 1 of 2)

STANDARD 406001-06

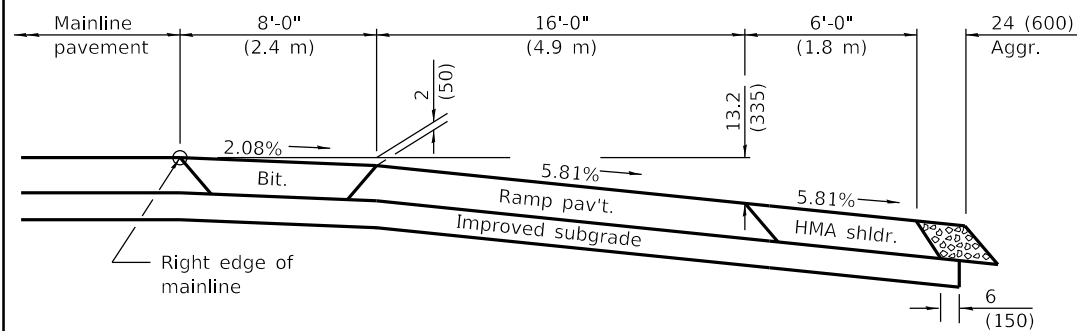

SECTION B-B

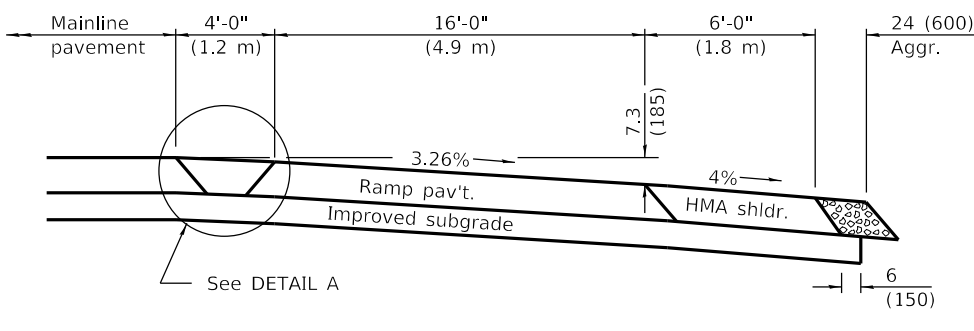

SECTION C-C

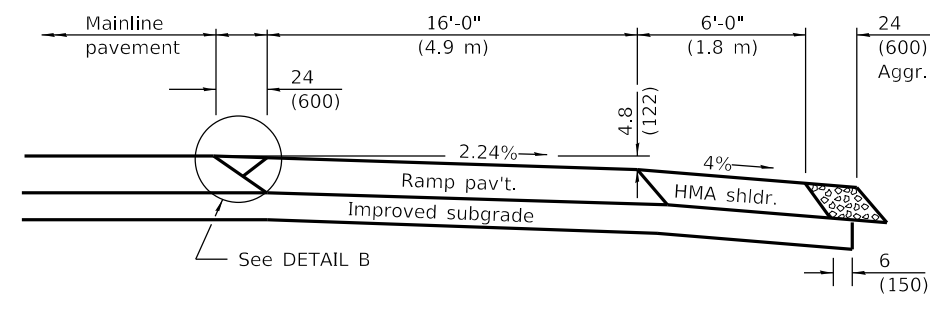

SECTION D-D

CROSS SECTIONS WHEN MAINLINE IS ON TANGENT OR CURVED TO THE RIGHT

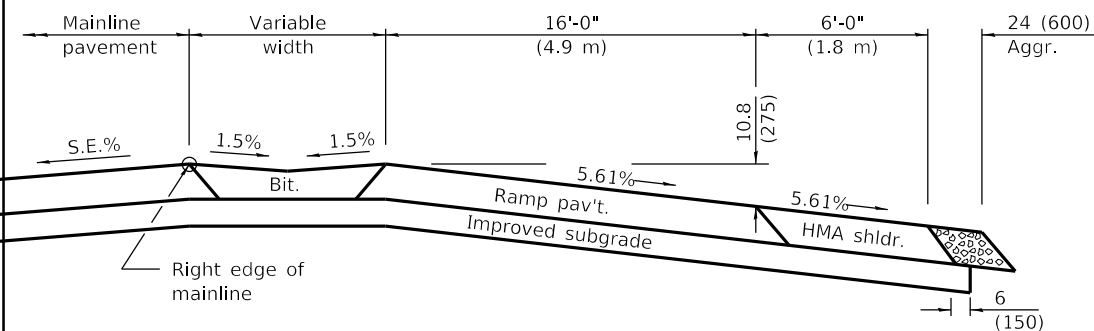

SECTION B-B

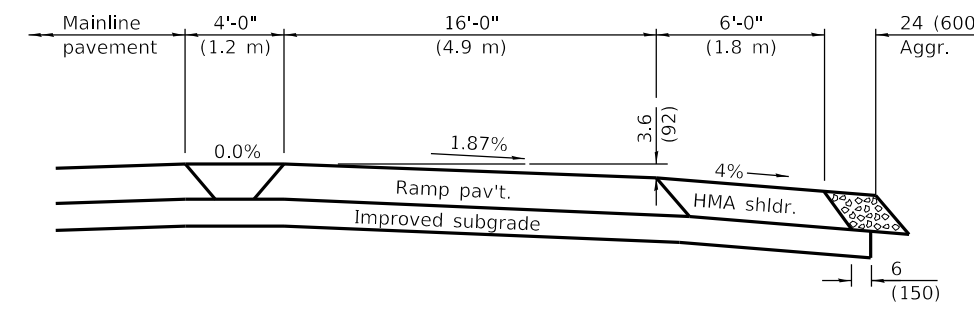

SECTION C-C

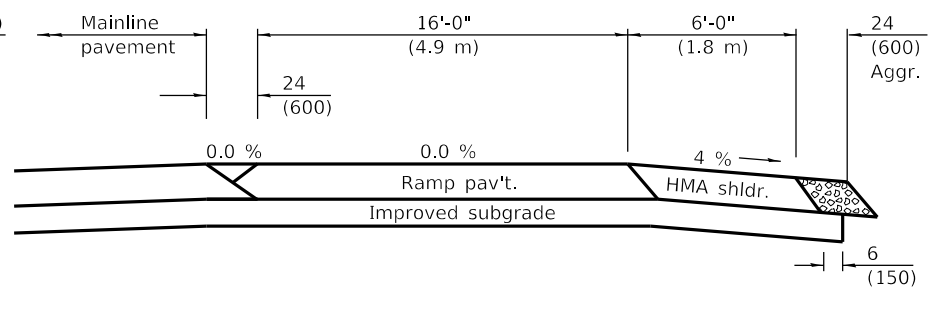

SECTION D-D

CROSS SECTIONS WHEN MAINLINE IS CURVED TO THE LEFT

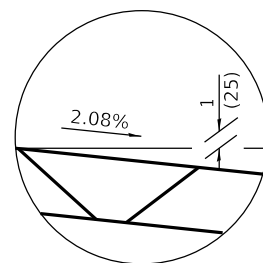

DETAIL A

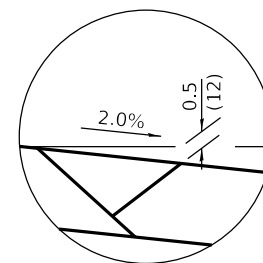

DETAIL B

Illinois Department of Transportation

PASSED January 1, 2015
Michael Beard
 ENGINEER OF POLICY AND PROCEDURES

APPROVED January 1, 2015
[Signature]
 ENGINEER OF DESIGN AND ENVIRONMENT

ISSUED 1-1-97

ENTRANCE RAMP TERMINAL
 (FLEXIBLE RAMP PAVEMENT ADJACENT TO FLEXIBLE MAINLINE PAVEMENT)
 (Sheet 2 of 2)

STANDARD 406001-06

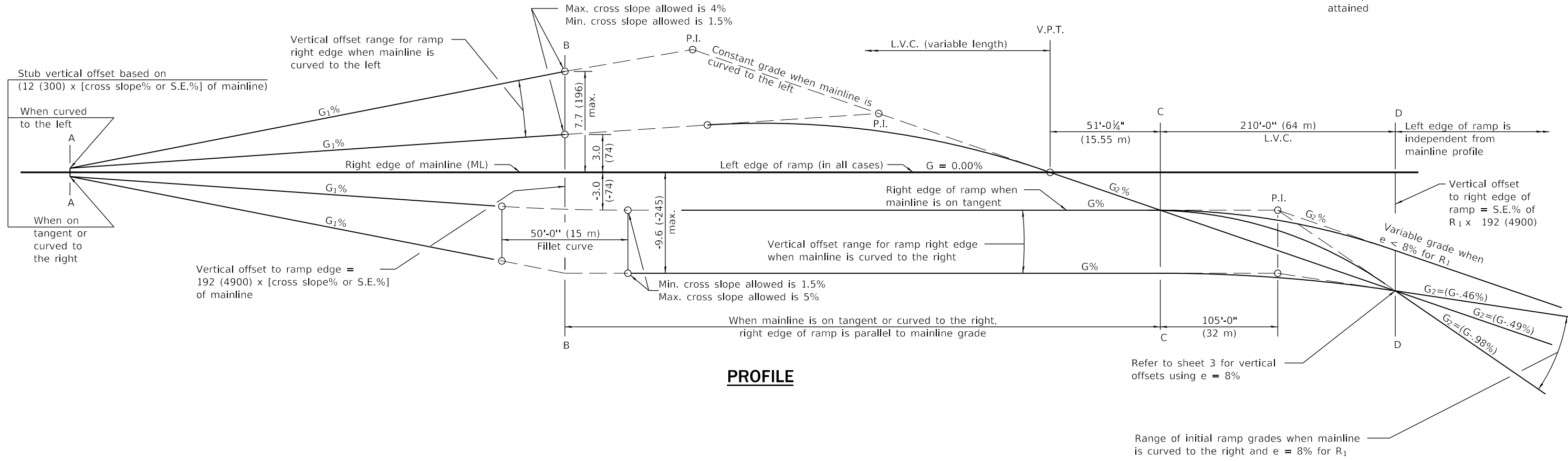
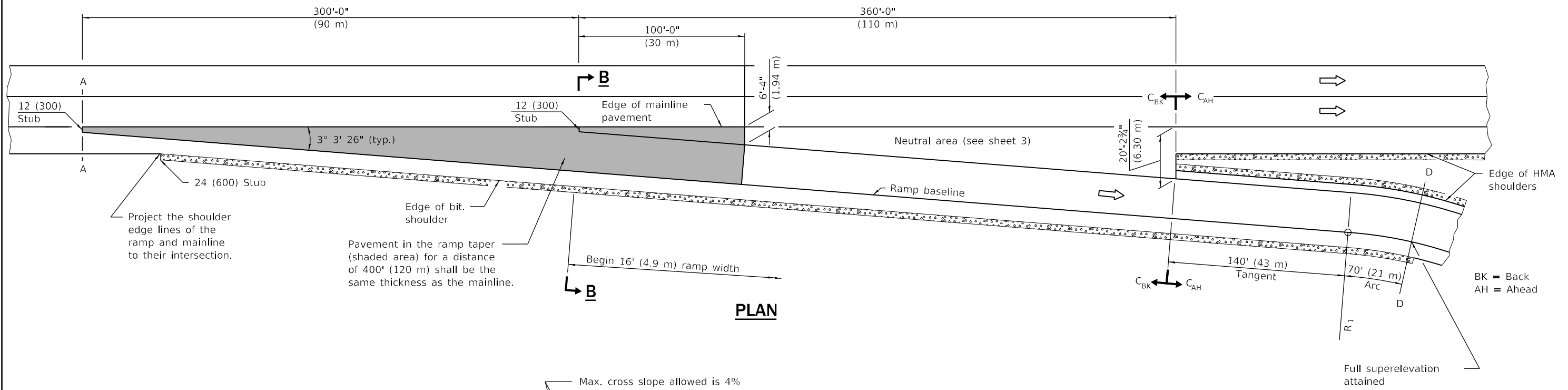

See Sheet 3 for GENERAL NOTES

Illinois Department of Transportation

PASSED January 1, 2015
Michael Beard
ENGINEER OF POLICY AND PROCEDURES

APPROVED January 1, 2015
[Signature]
ENGINEER OF DESIGN AND ENVIRONMENT

ISSUED 1-1-97

DATE	REVISIONS
1-1-15	Corrected divergence angle at taper. Based profile off of e-max instead of R ₁ .
1-1-08	Switched units to English (metric).

EXIT RAMP TERMINAL
(FLEXIBLE RAMP PAVEMENT ADJACENT TO FLEXIBLE MAINLINE PAVEMENT)
(Sheet 1 of 3)

STANDARD 406101-05

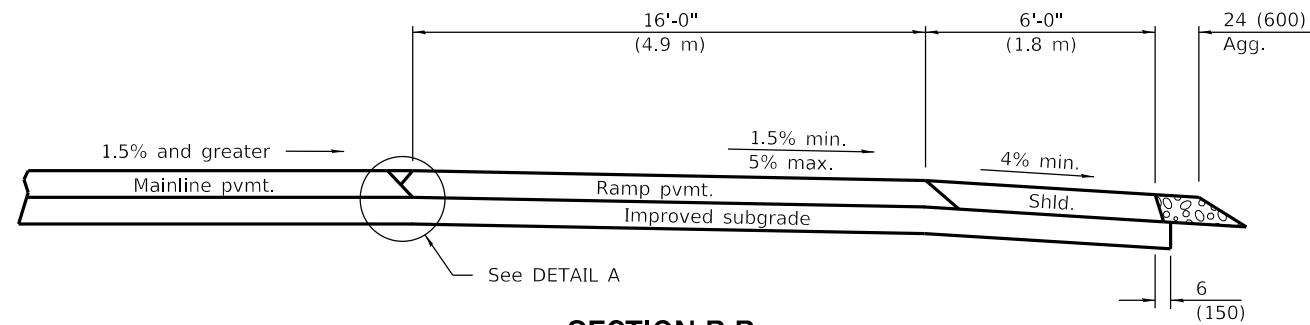

SECTION B-B

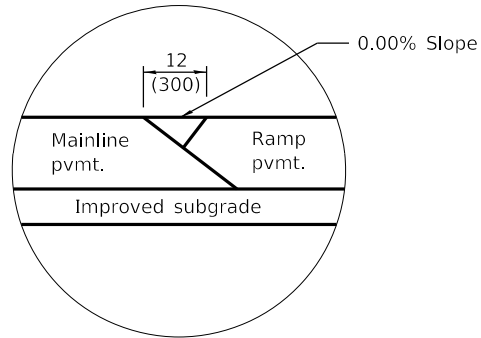

DETAIL A

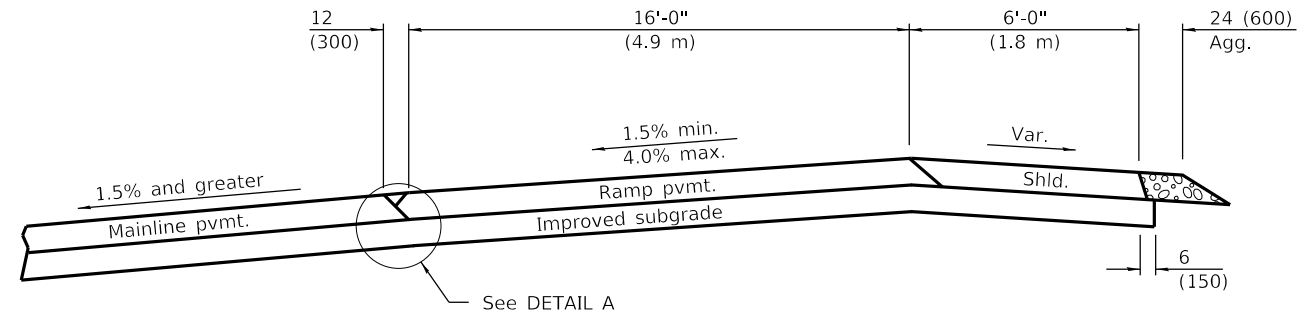

SECTION B-B

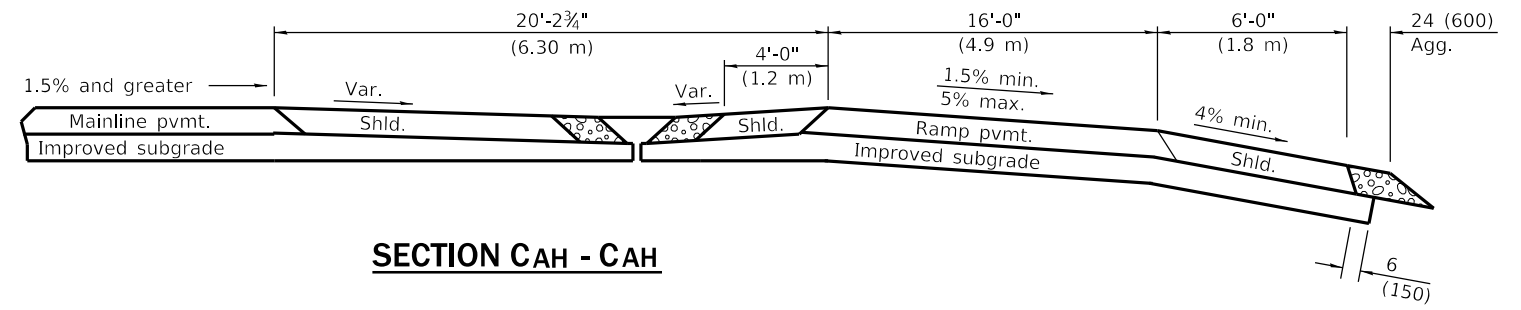

SECTION CAH - CAH

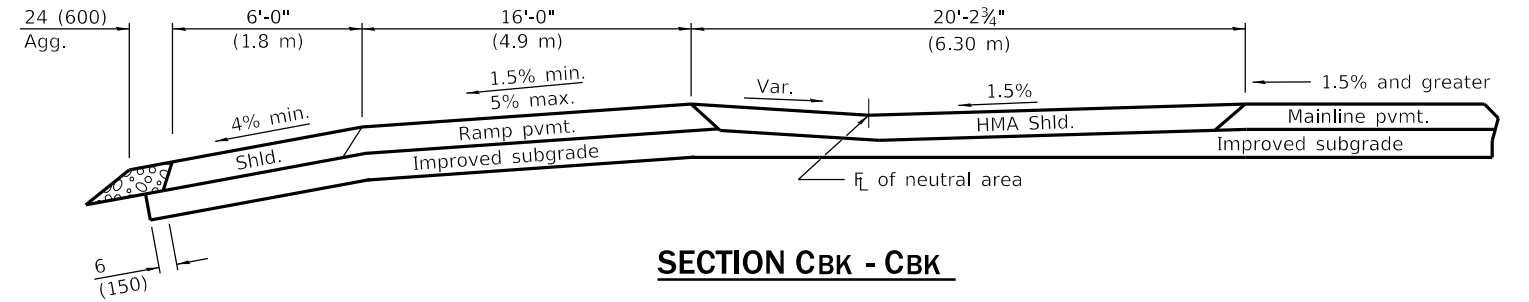

SECTION CBK - CBK

BK = Back
AH = Ahead

WHEN MAINLINE IS ON TANGENT OR CURVED TO THE RIGHT

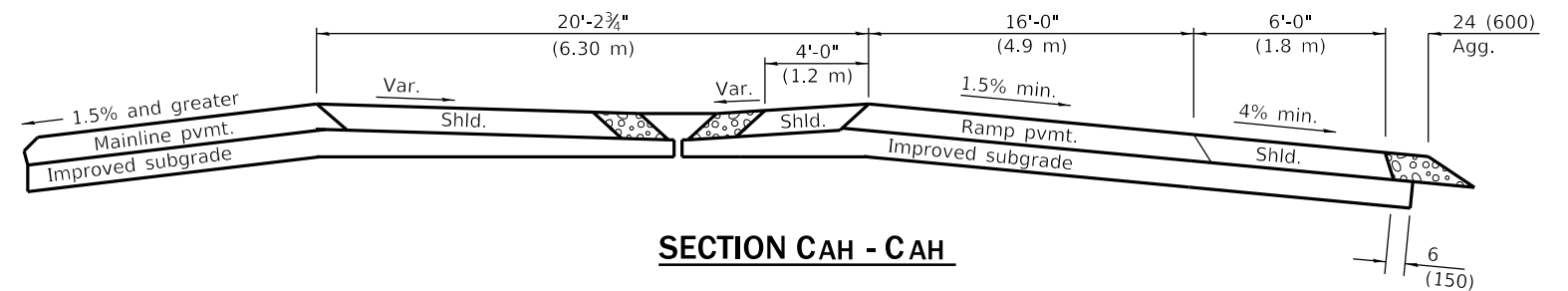

SECTION CAH - CAH

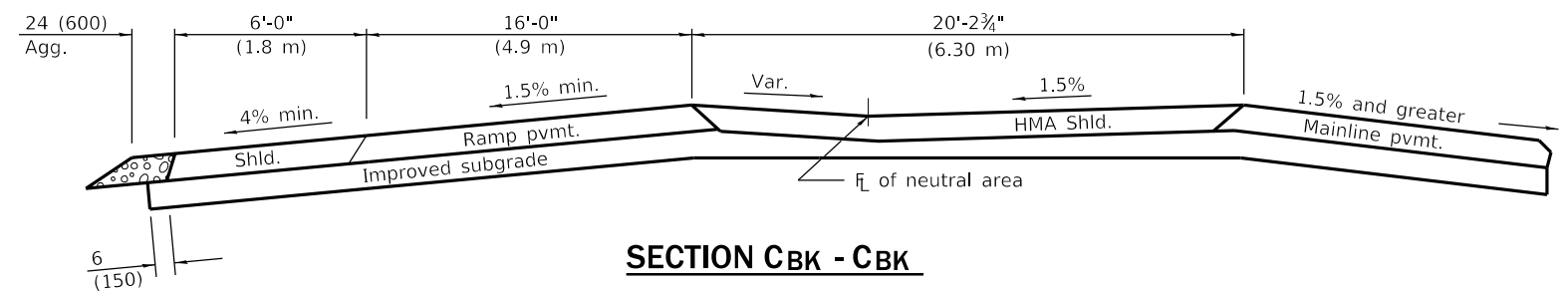

SECTION CBK - CBK

WHEN MAINLINE IS CURVED TO THE LEFT

See Sheet 3 for GENERAL NOTES

Illinois Department of Transportation

PASSED January 1, 2015
Michael Beard
 ENGINEER OF POLICY AND PROCEDURES

APPROVED January 1, 2015
[Signature]
 ENGINEER OF DESIGN AND ENVIRONMENT

ISSUED 1-1-97

EXIT RAMP TERMINAL
 (FLEXIBLE RAMP PAVEMENT ADJACENT
 TO FLEXIBLE MAINLINE PAVEMENT)

(Sheet 2 of 3)

STANDARD 406101-05

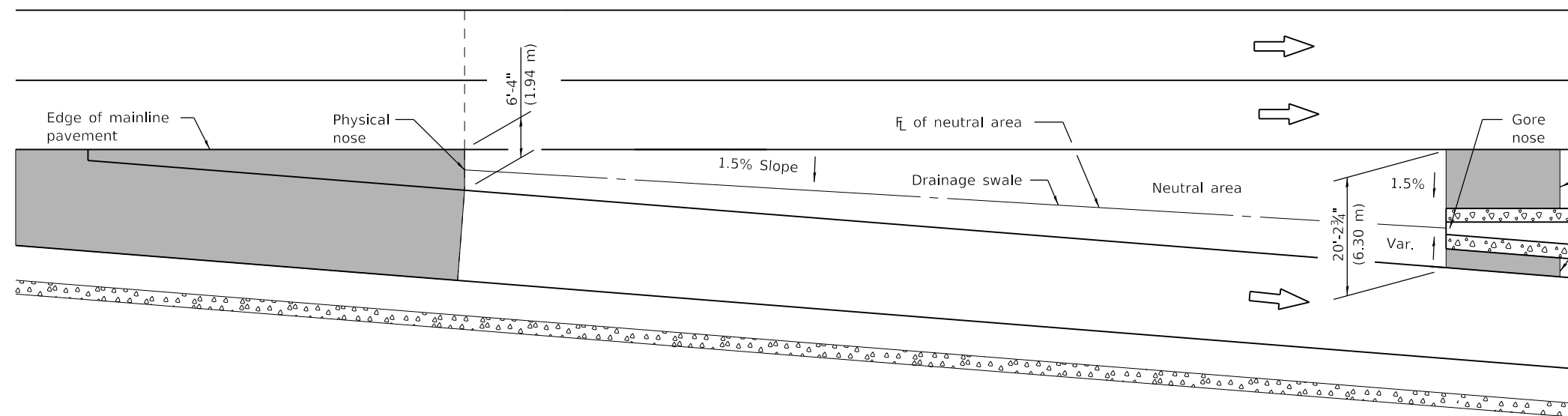

Shaded area indicates shoulder transition zone from neutral area to design shoulder slope. In this area, the relative profile grade difference along the outside pavement edge and that along the outside shoulder edge shall not exceed 0.50%.

DETAILS FOR DRAINAGE IN NEUTRAL AREA

① Vertical offsets in inches for right edge of ramp, when e = 8%			
Sections	Mainline on Tangent	Mainline Curved Right	Mainline Curved Left
A	- 0.18	S.E. % ML x 12	S.E. % ML x 12 ②
B	- 3.0	S.E. % ML x 192	S.E. % ML x 192 ②
C	- 3.0	S.E. % ML x 192	- 3.0
D	- 15.4	- 15.4	- 15.4

① Vertical offsets in mm for right edge of ramp, when e = 8%			
Sections	Mainline on Tangent	Mainline Curved Right	Mainline Curved Left
A	- 5	S.E.% ML x 300	S.E.% ML x 300 ②
B	- 74	S.E.% ML x 4900	S.E.% ML x 4900 ②
C	- 74	S.E. % ML x 4900	- 74
D	- 392	- 392	- 392

- ① Vertical offset values are calculated and based on the right edge of mainline pavement at 0.0 % grade.
- ② The vertical offsets of these points are above the mainline pavement and lie on an upgrade in relationship to the mainline grade.
- ③ S.E.=Superelevation Rate

GENERAL NOTES

The initial ramp grade (G₂) is based on the line generated through the PI that is 105 ft. (32 m) past Section C-C and the point created by the vertical offset at Section D-D.

See plans for actual grades.

See Standard 482001 for ramp shoulder details.

In the neutral area, provide a swale and flush inlet to enhance drainage.

When using grades expressed in %, the grade values shall be divided by 100 to obtain vertical offsets.

Where an exit ramp terminal is proposed adjacent to a mainline horizontal curve, construct the edge of the terminal by using offset widths, and for the terminal segment downstream from Section C-C to R₁, construct the ramp as a 140 ft. (43 m) tangent section.

All dimensions are in inches (millimeters) unless otherwise shown.

EXIT RAMP TERMINAL

(FLEXIBLE RAMP PAVEMENT ADJACENT TO FLEXIBLE MAINLINE PAVEMENT)

(Sheet 3 of 3)

STANDARD 406101-05

Illinois Department of Transportation

PASSED January 1, 2015
Michael Beard
 ENGINEER OF POLICY AND PROCEDURES

APPROVED January 1, 2015
[Signature]
 ENGINEER OF DESIGN AND ENVIRONMENT

ISSUED 1-1-97

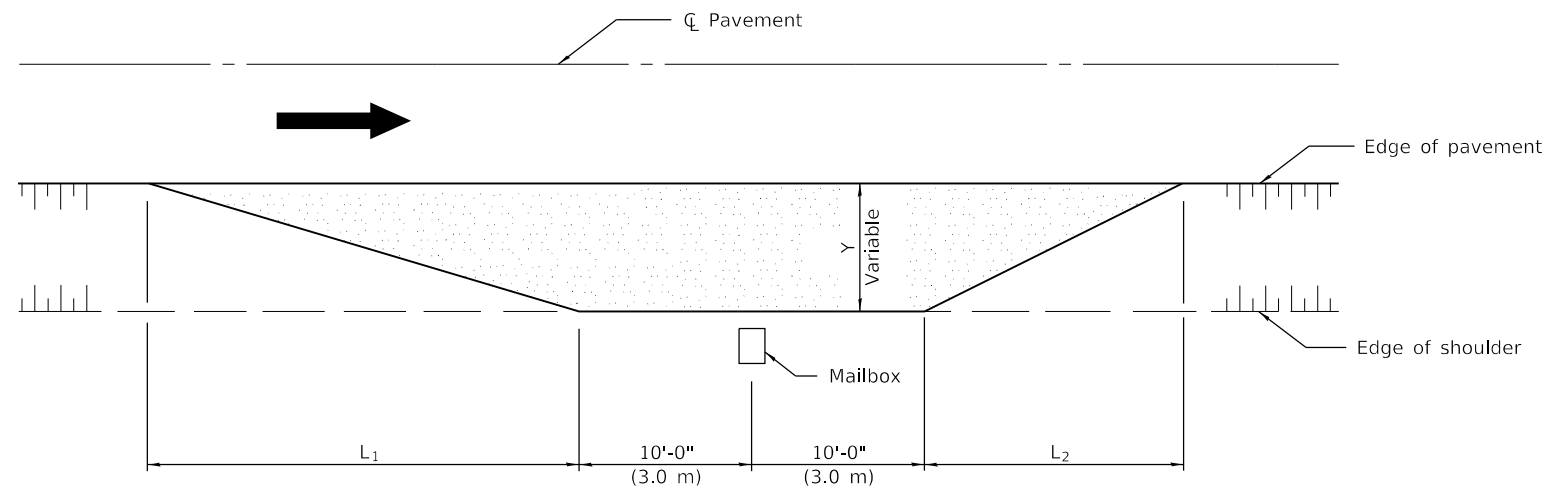

TYPICAL APPLICATION

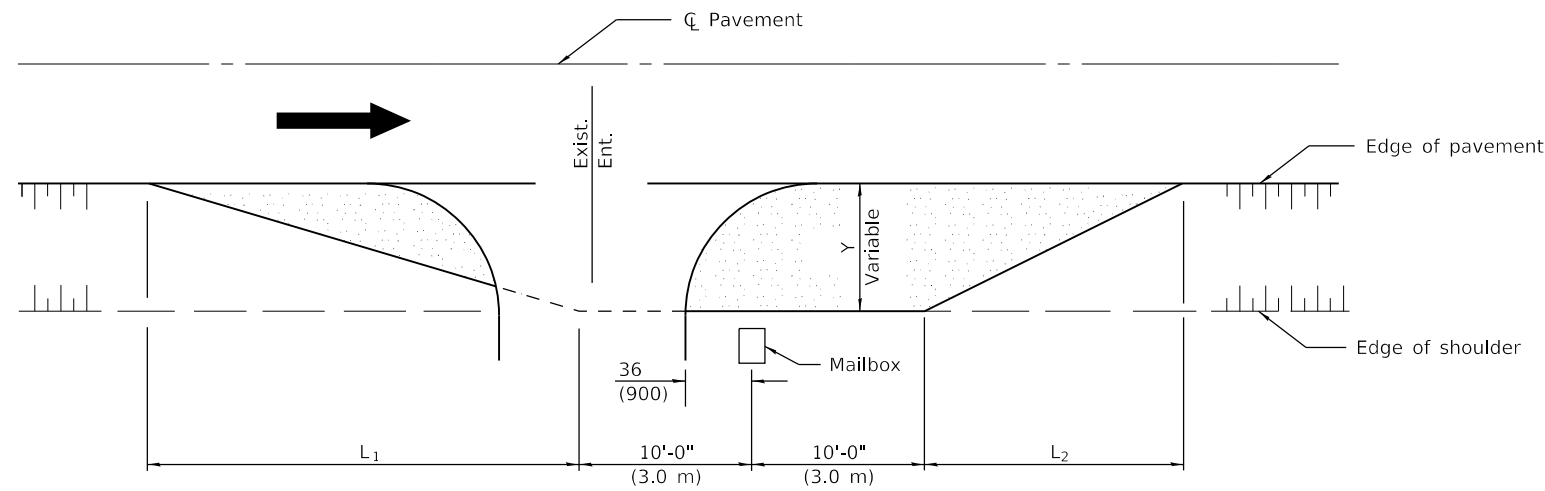

MAILBOX ON FAR SIDE OF ENTRANCE

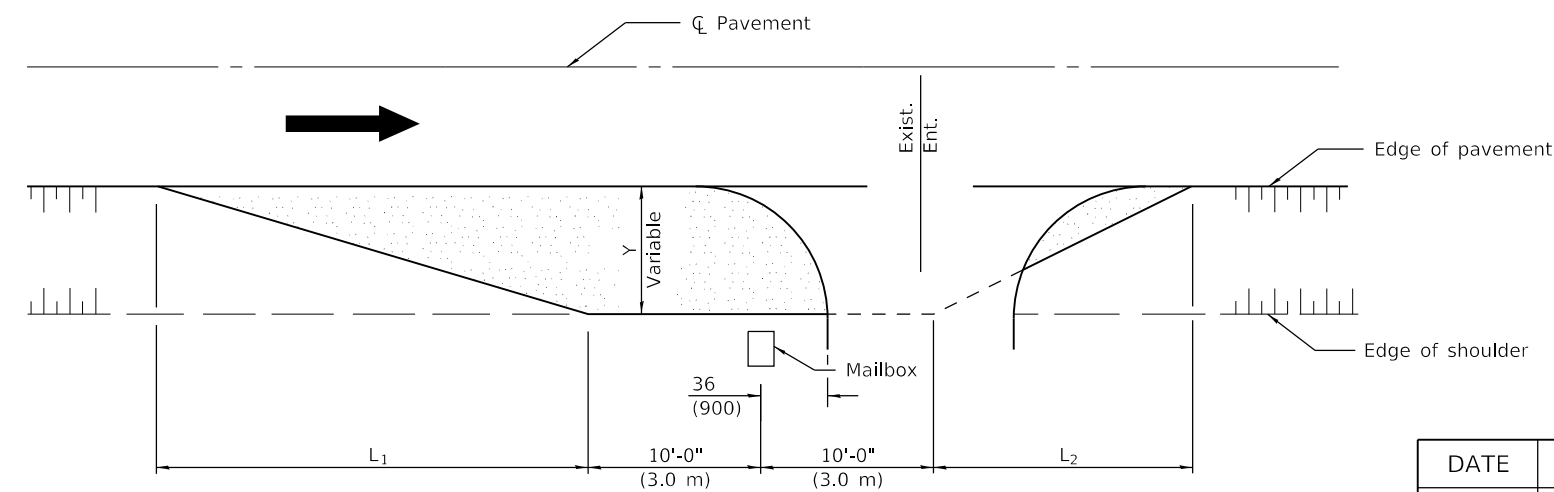

MAILBOX ON NEAR SIDE OF ENTRANCE

DIMENSIONS - ft. (m)		
Width of Shoulder	4-8 (1.2-2.4)	10 (3.0)
Width of Turnout (Y)	8 (2.4)	8-10 (2.4-3.0)
L ₁	32 (9.5)	32 (9.5)
L ₂	20 (6.0)	20 (6.0)

GENERAL NOTES

Mailboxes shall be mounted such that the face of the mailbox is 6 (150) to 12 (300), and the post a minimum of 24 (600), from the edge of the turnout surfacing.

All dimensions are in inches (millimeters) unless otherwise shown.

DATE	REVISIONS
1-1-08	Switched units to English (metric).
1-1-97	Renum. Standard 2171-1.
	Deleted note regarding Township & Dist. roads

MAILBOX TURNOUT

STANDARD 406201-01

Illinois Department of Transportation
 PASSED January 1, 2008
 ENGINEER OF POLICY AND PROCEDURES
 APPROVED January 1, 2008
 ENGINEER OF DESIGN AND ENVIRONMENT

ISSUED 1-1-97

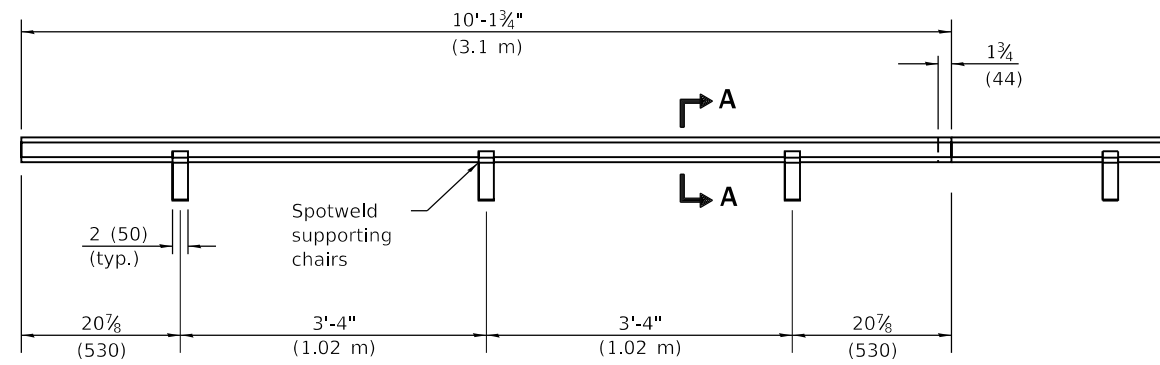

Sheet steel of suitable thickness to form keyway as detailed or approved equal.

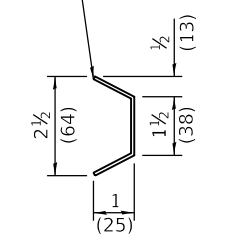

TYPE C METAL JOINT

SECTION A-A

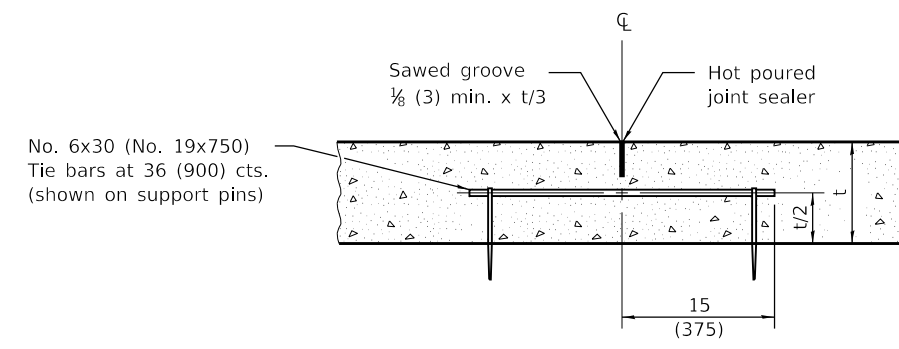

LONGITUDINAL SAWED JOINT

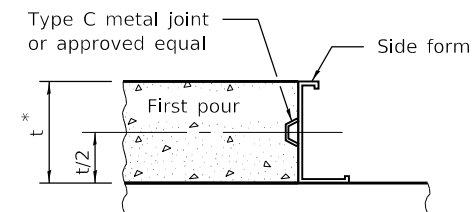

LONGITUDINAL KEYED JOINT

* 8 (203) min. pavement thickness for keyed joints.

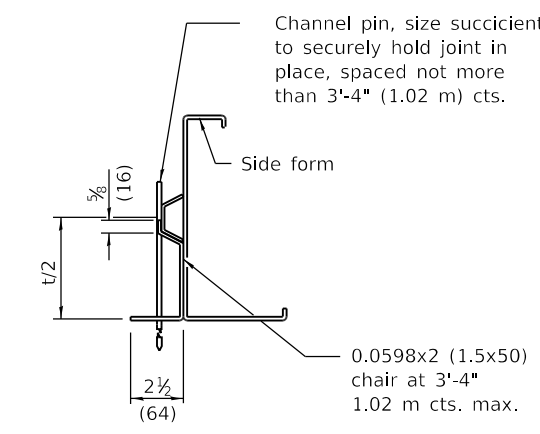

SUPPORTING CHAIR ALTERNATE

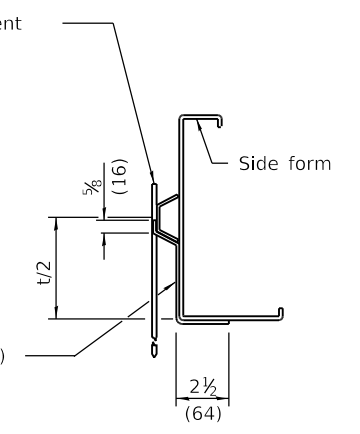

SUPPORTING CHAIR ALTERNATE

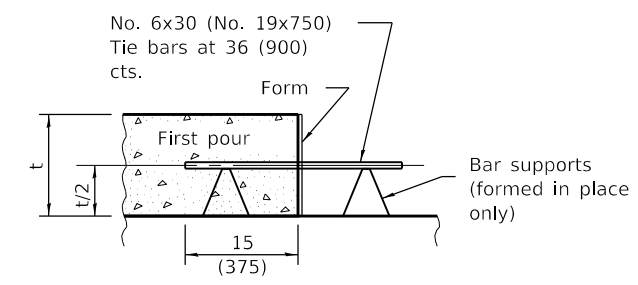

LONGITUDINAL CONSTRUCTION JOINT
(TIE BAR FORMED IN PLACE OR MECHANICALLY INSERTED)

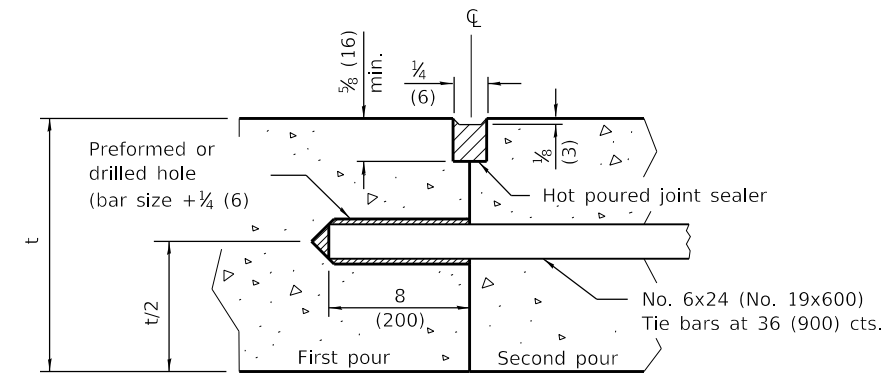

LONGITUDINAL CONSTRUCTION JOINT
(TIE BAR GROUTED IN PLACE)

GENERAL NOTES

All slope ratios are expressed as units of vertical displacement to units of horizontal displacement (V:H).

All dimensions are in inches (millimeters) unless otherwise shown.

Illinois Department of Transportation

PASSED January 1, 2022
Michael Beard
ENGINEER OF POLICY AND PROCEDURES

APPROVED January 1, 2022
Scott Cbe
ENGINEER OF DESIGN AND ENVIRONMENT

ISSUED 1-1-97

DATE	REVISIONS
1-1-22	Revised DOWEL BAR TABLE on Sheet 2.
1-1-18	Changed tie bar spacing to 36 (900) cts. Revised DOWEL BAR TABLE.

PAVEMENT JOINTS

(Sheet 1 of 2)

STANDARD 420001-10

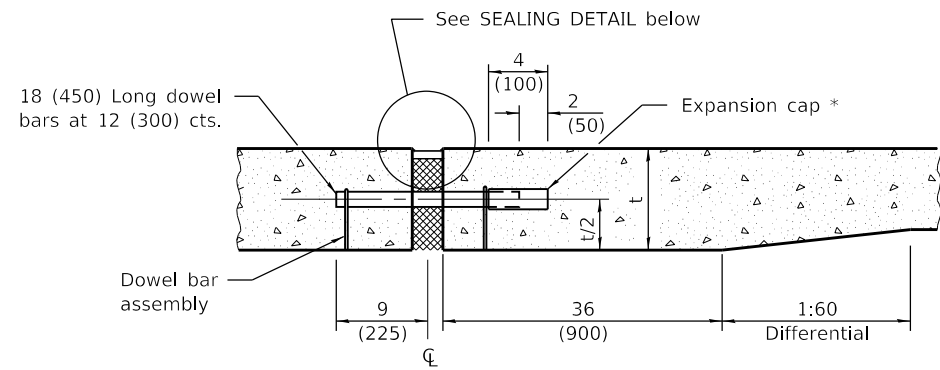

TRANSVERSE EXPANSION JOINT
(FOR PAVEMENTS WITH UNEQUAL THICKNESS)

* Expansion caps shall be installed on the exposed end of each dowel bar once the header has been removed and the joint filler material has been installed.

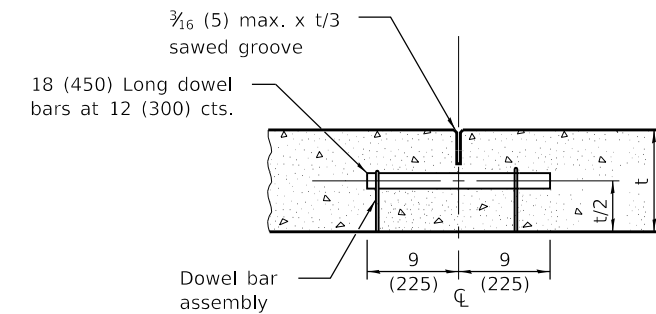

TRANSVERSE CONTRACTION JOINT

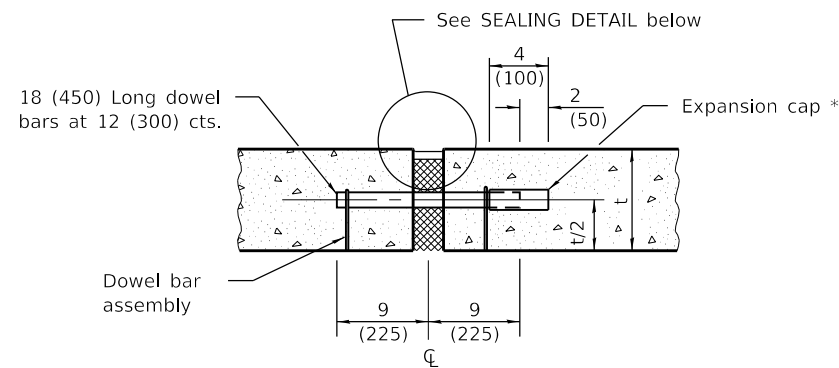

TRANSVERSE EXPANSION JOINT
(FOR PAVEMENTS WITH EQUAL THICKNESS)

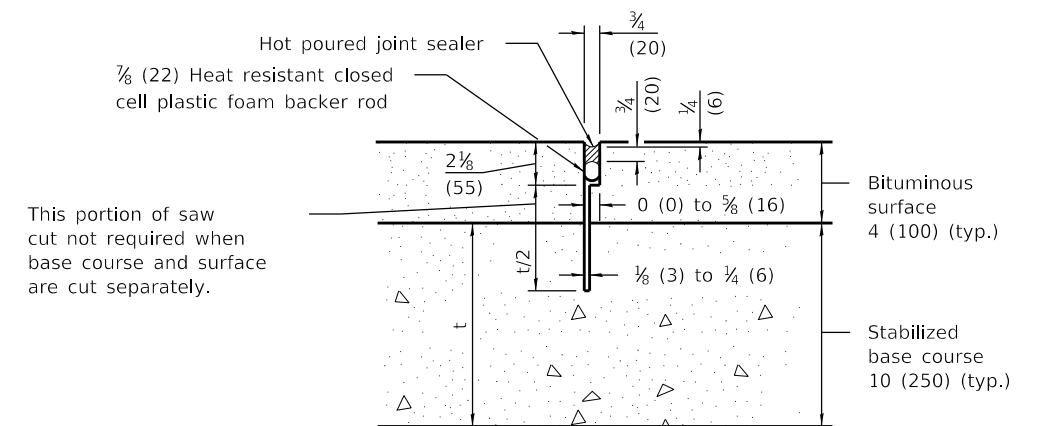

TRANSVERSE CONTRACTION JOINT
(FOR CAM, CFA AND LFA BASE COURSE MIXTURES)

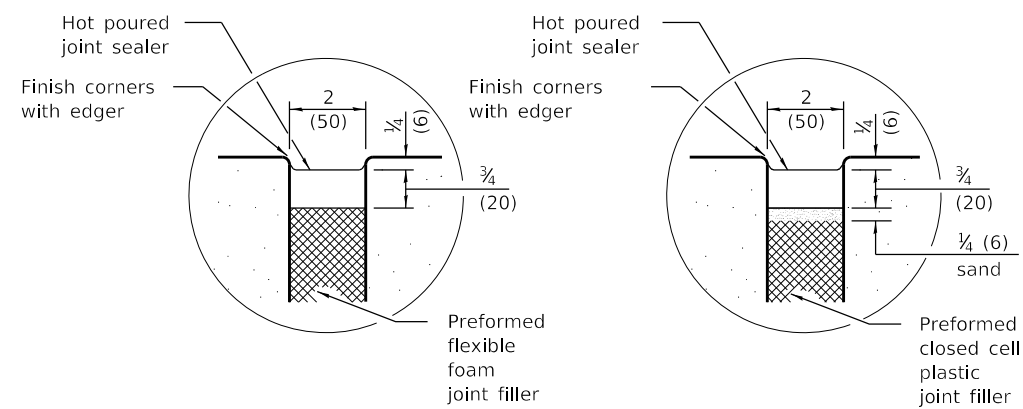

SEALING DETAIL

DOWEL BAR TABLE	
PAVEMENT THICKNESS	DOWEL BAR DIAMETER
10 (250) and greater	1 1/2 (38)
8.01 (201) thru 9.99 (249)	1 1/4 (32)
8 (200) and less	1 (25)

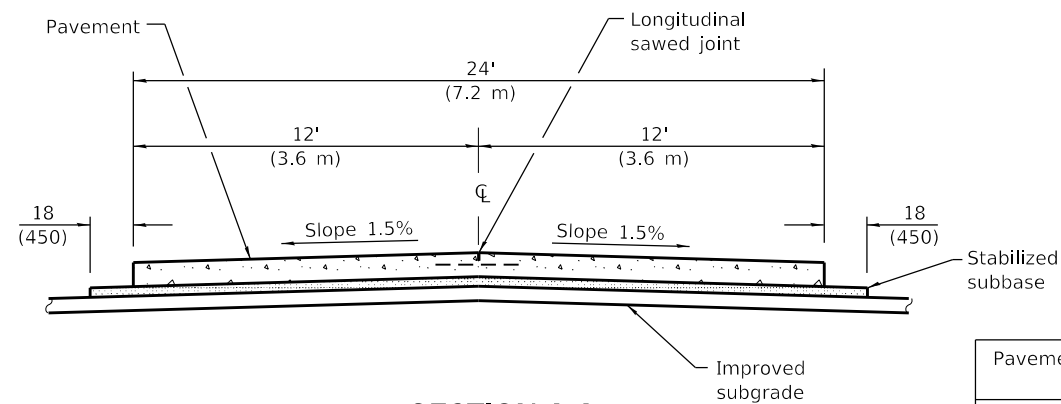

SECTION A-A
(TYPICAL 2-LANE WITH SHOULDERS)

Pavement Thickness	Spacing of Transverse Contraction Joints
Less than 10 (250)	12' (3.6 m) *
10 (250) and greater	15' (4.5 m) *

* When placed adjacent to existing PCC pavement, use a spacing between 12' (3.6 m) and 18' (5.5 m) so the joints are in prolongation with existing transverse joints. Also adjust the spacing of tie bars in the longitudinal joint(s) to maintain a clearance of 9 (225) from the end of the dowel bars.

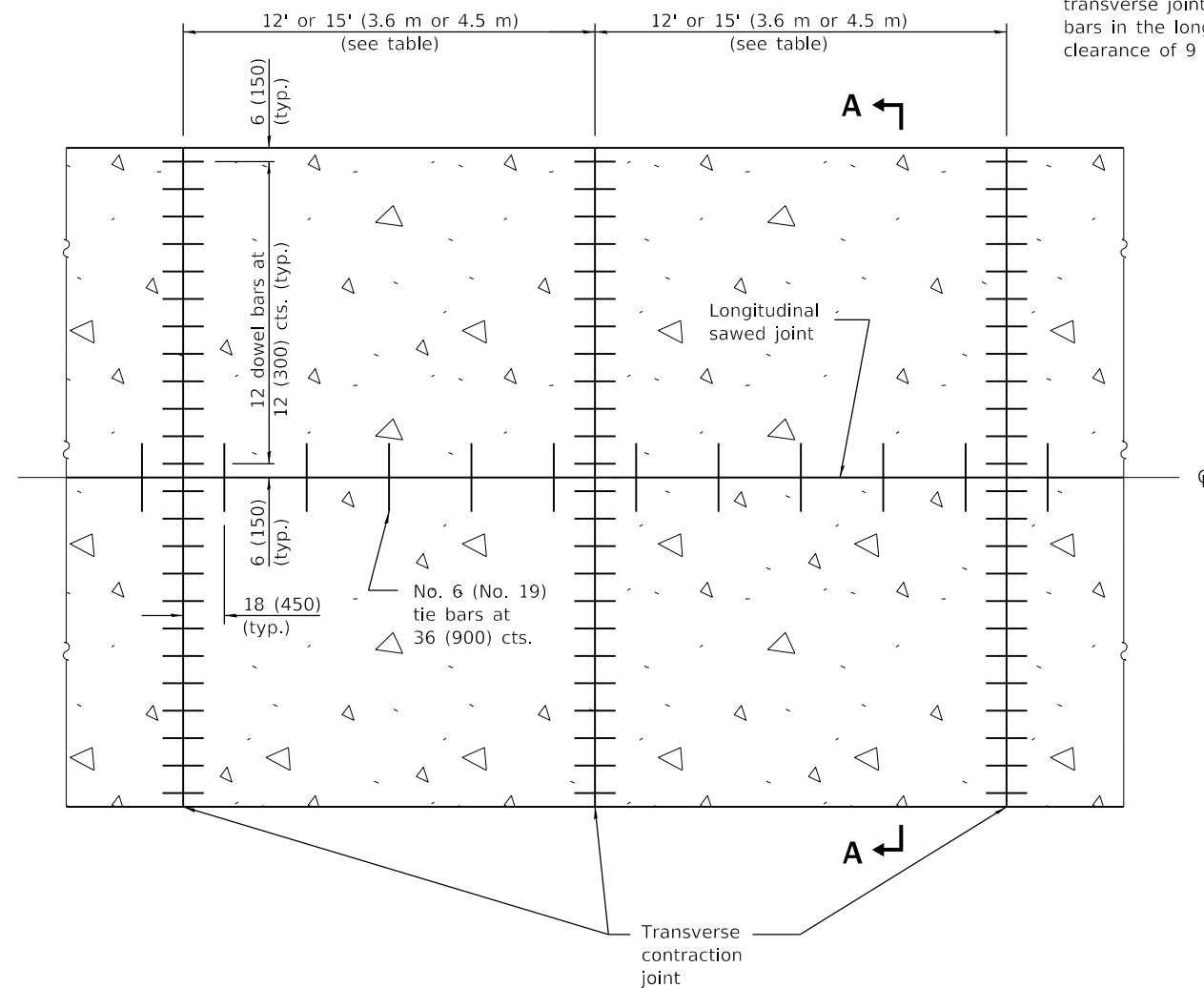

PAVEMENT PLAN

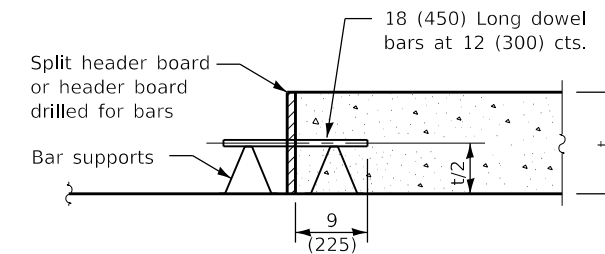

TRANSVERSE CONSTRUCTION JOINT

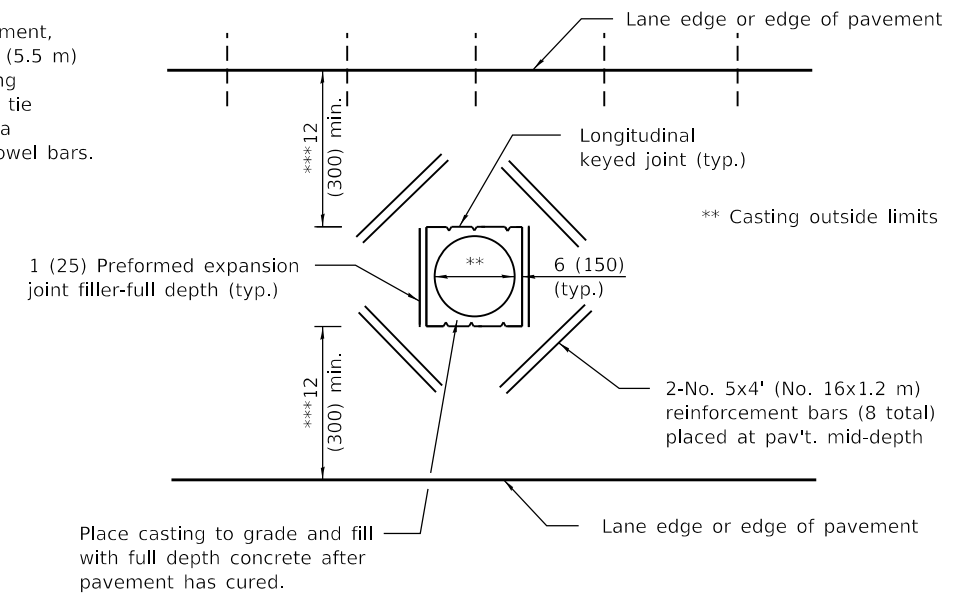

DETAIL OF ADDED REINFORCEMENT FOR PAVEMENT BLOCKS-OUTS

*** When the 12 (300) minimum cannot be achieved, the transverse joints shall be extended to either the longitudinal joint or edge of pavement.

GENERAL NOTES

See Standard 420001 for details of joints not shown.

All dimensions are in inches (millimeters) unless otherwise shown.

Illinois Department of Transportation

PASSED January 1, 2022
Michael Beard
ENGINEER OF POLICY AND PROCEDURES

APPROVED January 1, 2022
John C. ...
ENGINEER OF DESIGN AND ENVIRONMENT

ISSUED 1-1-97

DATE	REVISIONS
1-1-22	Revised spacing of transverse contraction joints and header board callout.
1-1-18	Changed spacing of tie bars to 36 (900).

24' (7.2 m) JOINTED PCC PAVEMENT

STANDARD 420101-07

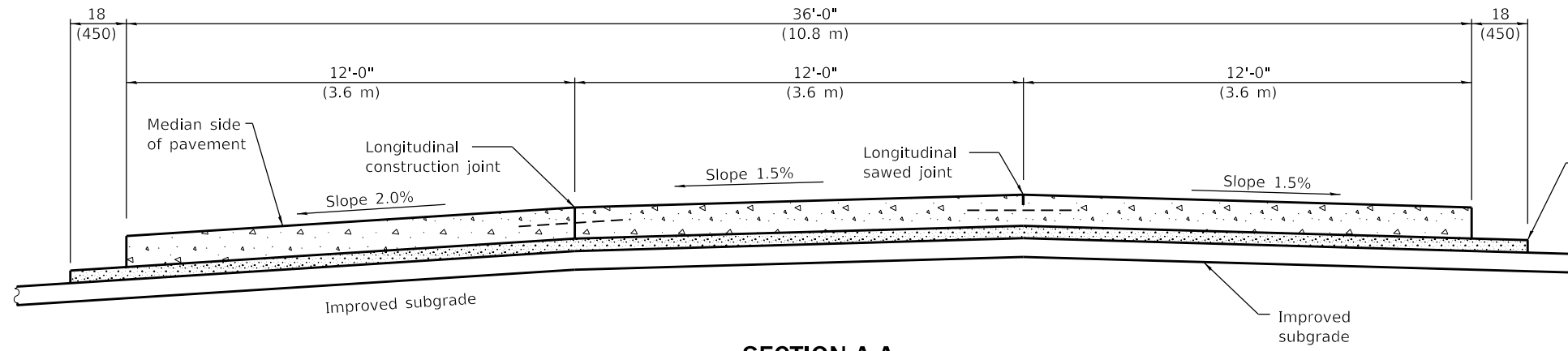

SECTION A-A
(TYPICAL 3-LANE, 1-WAY WITH SHOULDERS)

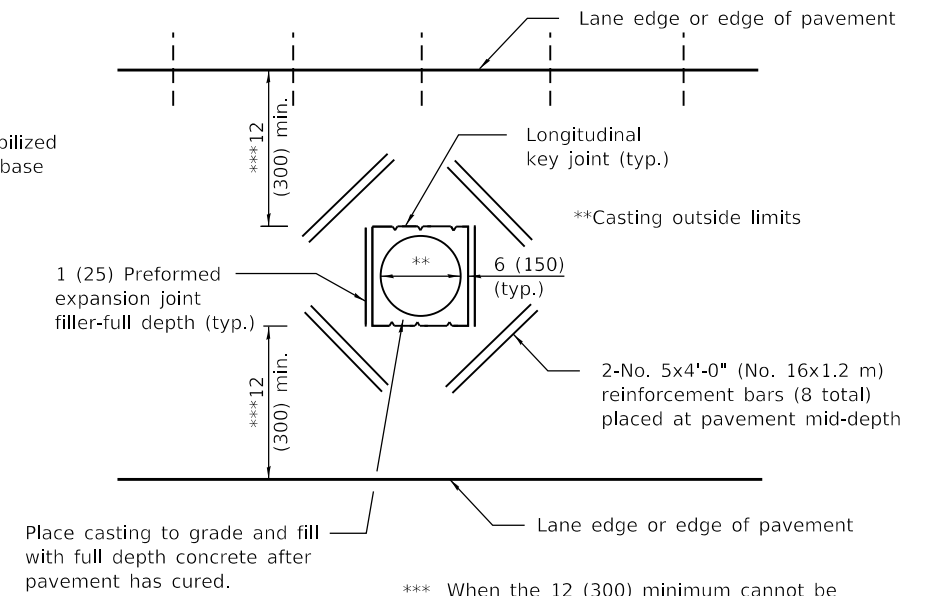

*** When the 12 (300) minimum cannot be achieved, the transverse joints shall be extended to either the longitudinal joint or edge of pavement.

DETAIL OF ADDED REINFORCEMENT FOR PAVEMENT BLOCK-OUTS

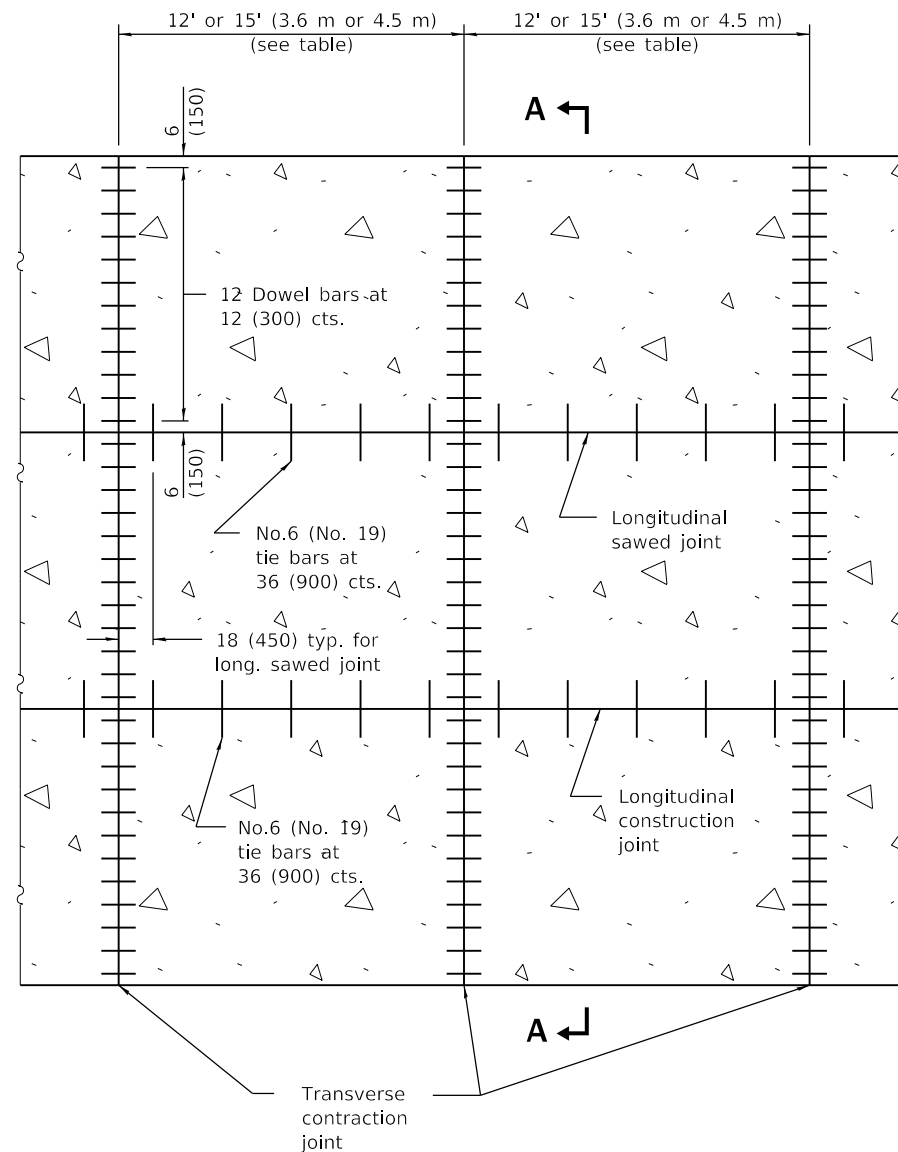

PAVEMENT PLAN

Pavement Thickness	Spacing of Transverse Contraction Joints
Less than 10 (250)	12' (3.6 m) *
10 (250) and greater	15' (4.5 m) *

* When placed adjacent to existing PCC pavement, use a spacing between 12' (3.6 m) and 18' (5.5 m) so the joints are in prolongation with existing transverse joints. Also adjust the spacing of tie bars in the longitudinal joint(s) to maintain a clearance of 9 (225) from the end of the dowel bars.

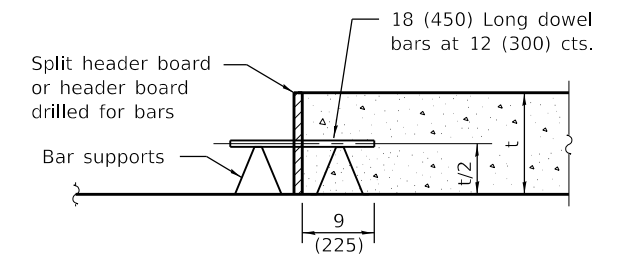

TRANSVERSE CONSTRUCTION JOINT

GENERAL NOTES

See Standard 420001 for details of joints not shown.

All dimensions are in inches (millimeters) unless otherwise shown.

DATE	REVISIONS
1-1-22	Revised spacing of transverse contraction joints and header board callout.
1-1-15	Changed spacing of tie bars to 36 (900).

36' (10.8 m) JOINTED PCC PAVEMENT

STANDARD 420106-07

Illinois Department of Transportation

PASSED January 1, 2022
Michael Beard
ENGINEER OF POLICY AND PROCEDURES

APPROVED January 1, 2022
John C. ...
ENGINEER OF DESIGN AND ENVIRONMENT

ISSUED 1-1-97

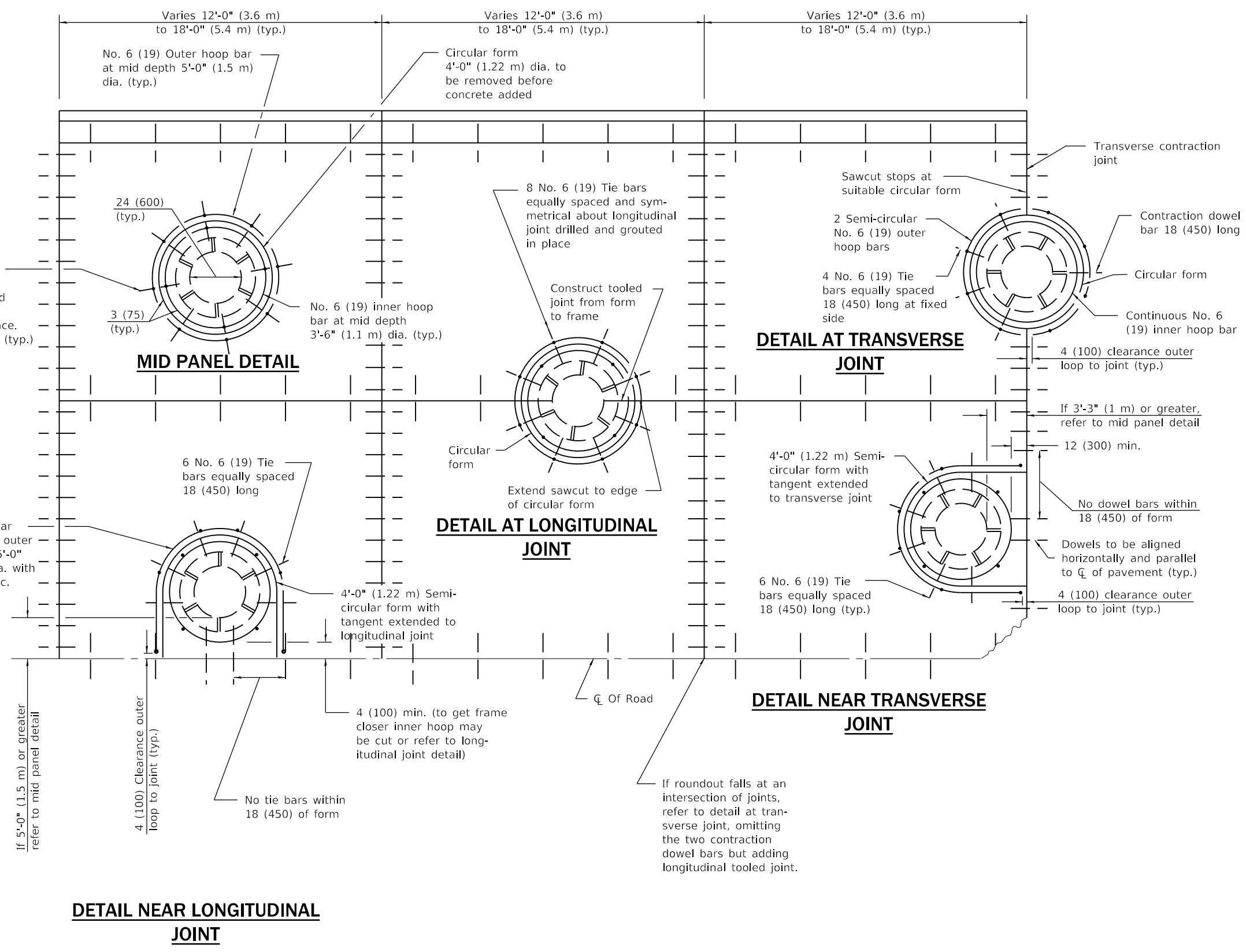

GENERAL NOTES

Transverse joints may be moved to accommodate roundout. Edge of circular joint shall be minimum 24 (600) from transverse joint. Relocated transverse joint shall be continuous from edge of pavement to edge of pavement.

The transverse joint spacing should be adjusted to use the DETAIL NEAR TRANSVERSE JOINT. If the joint cannot be adjusted to give the 12 (300) min. offset, use the DETAIL AT TRANSVERSE JOINT and ensure the joint is centered in the structure as shown.

Circular form shall be removed prior to drill and grout of tie bars.

Drill and grout is preferred, however tie bars can be poured in place if clearance is provided to outer edge of frame. Maximum 2 (50) clearance.

Shims shall be used to adjust all frames. After adjusting mortar has cured, the shims shall be removed and the voids under the frames filled with nonshrink grout.

Hoop reinforcement shall be one piece construction having a minimum lap length of 24 (600).

All situations not shown and may require combination of details.

WHEN USING CAST IN PLACE:
Frame shall be anchored to the structure to prevent movement during the paving operation.

All dimensions are in inches (millimeters) unless otherwise shown.

Illinois Department of Transportation

PASSED January 1, 2018
Michael Beard
ENGINEER OF POLICY AND PROCEDURES

APPROVED January 1, 2018
Marcus M. Adams
ENGINEER OF DESIGN AND ENVIRONMENT

ISSUED 1-1-97

DATE	REVISIONS
1-1-18	Revised standard for 36 (900) tie bar spacing. Revised General Notes.
1-1-11	Corrected 'T/2' dim. on DETAIL OF REINFORCEMENT FOR PAVEMENT ROUNDOUT.

PCC PAVEMENT ROUNDOUTS
(Sheet 1 of 2)

STANDARD 420111-04

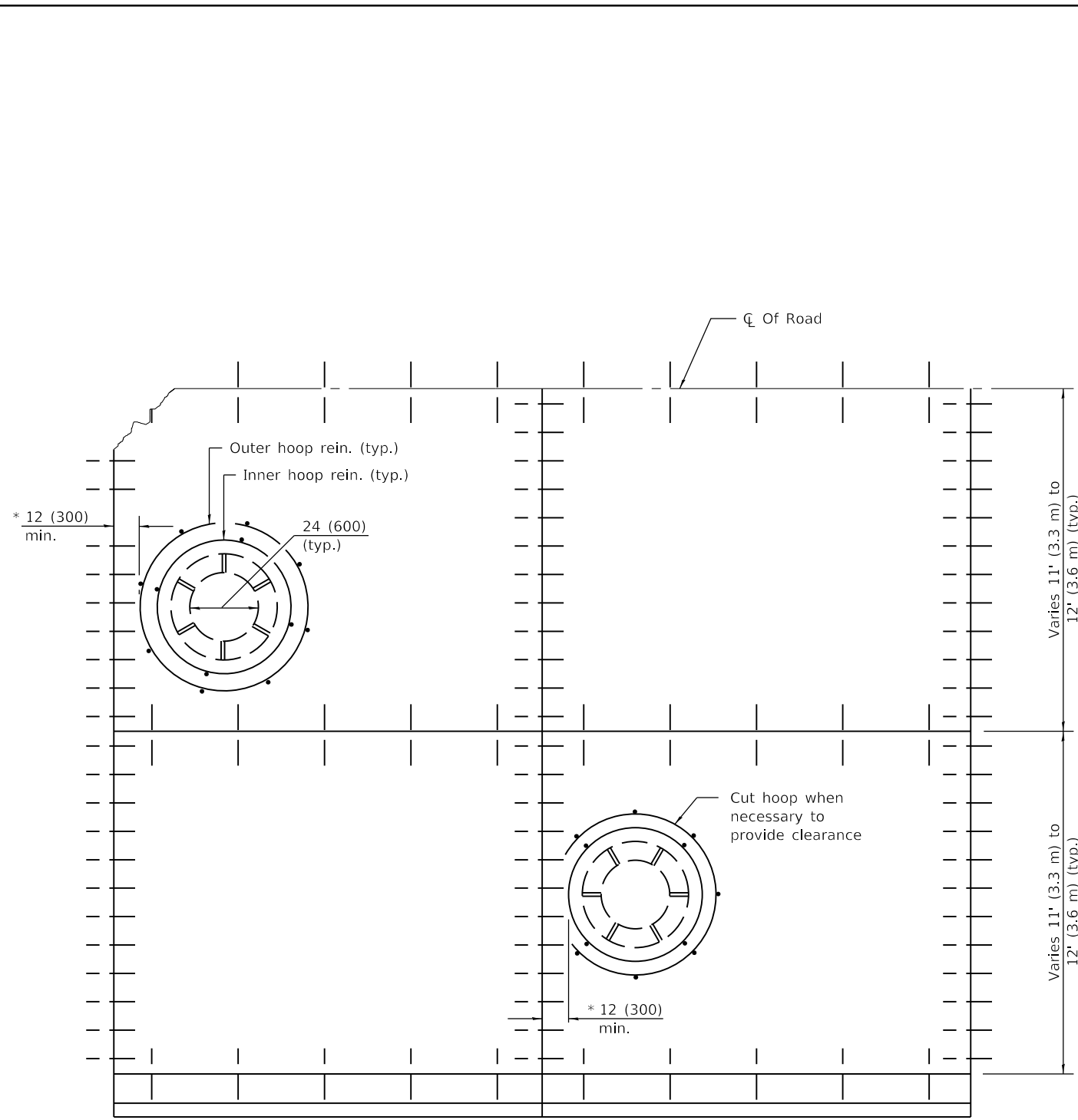

CAST IN PLACE DETAIL

* Less than 12 (300) formed roundout to be used.

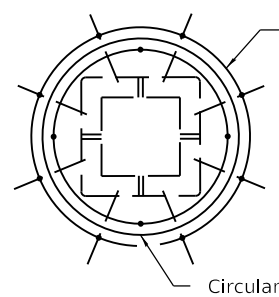

ROUNDOUT FOR SQUARE FRAME & GRATE AND MANHOLES

All dimensions same for the majority of circular frame & grates. For larger structures increase hoop bar and circular form diameter by 12 (300) each and add two additional equally spaced tie bars.

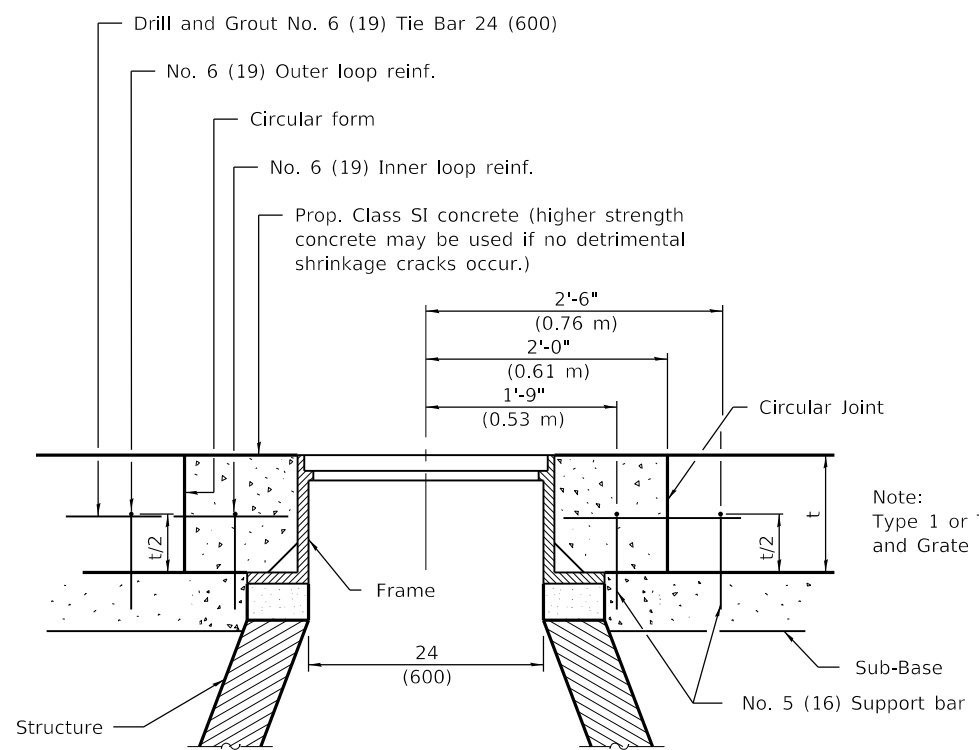
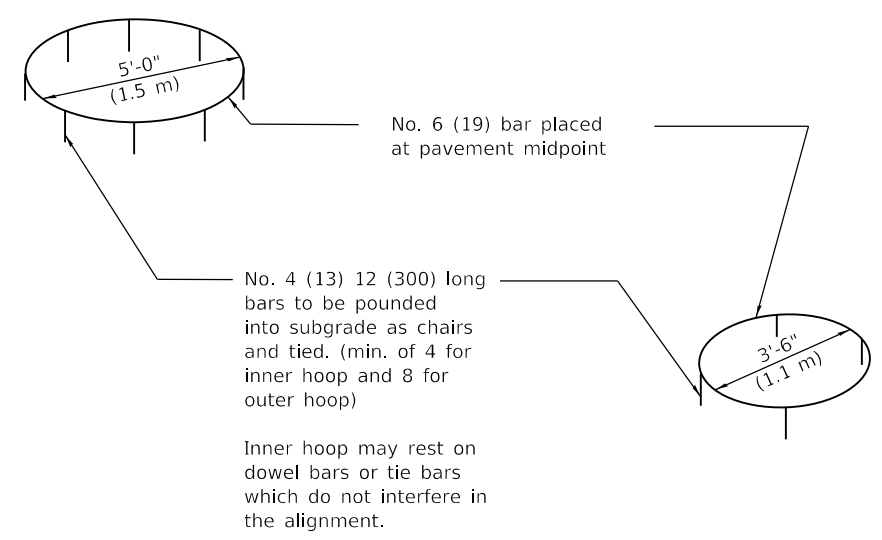

DETAIL OF REINFORCEMENT FOR PAVEMENT ROUNDOUT

Note: Type 1 or Type 5 Frame and Grate may be used

Illinois Department of Transportation

PASSED January 1, 2018
Michael Beard
 ENGINEER OF POLICY AND PROCEDURES

APPROVED January 1, 2018
Maureen M. Beck
 ENGINEER OF DESIGN AND ENVIRONMENT

ISSUED 1-1-97

PCC PAVEMENT ROUNDOUTS
 (Sheet 2 of 2)

STANDARD 420111-04

* This distance shall be adjusted to place the transverse expansion joint in prolongation with the existing joint in the mainline pavement.

Longitudinal sawed joint or a longitudinal construction joint with No. 6 (No. 19) tie bars at 36 (900) cts. for a distance of 100' (30 m) beginning at the 24 (600) stub. Joint line is parallel to ramp baseline.

Pavement thickness and joint type in the ramp taper, for a distance of 950' (290 m), shall be the same as the mainline. Joints shall be in prolongation with mainline pavement joints.

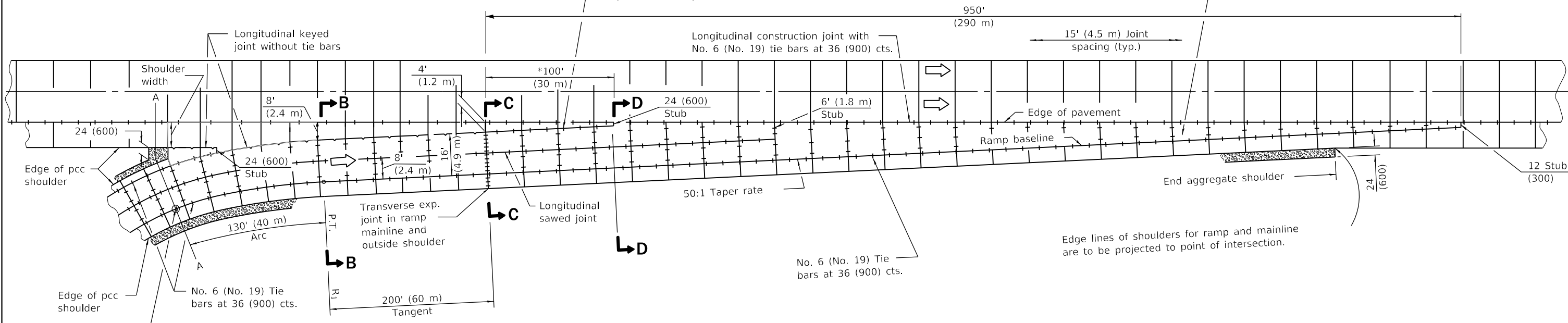

PLAN

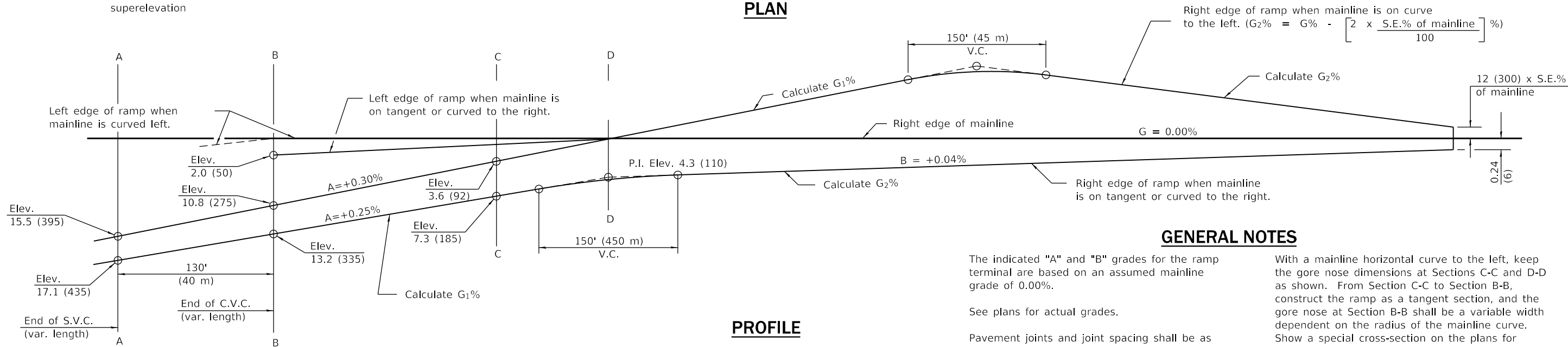

PROFILE

GENERAL NOTES

The indicated "A" and "B" grades for the ramp terminal are based on an assumed mainline grade of 0.00%.

See plans for actual grades.

Pavement joints and joint spacing shall be as shown on Standards 420001, 420101 and 420106.

See Standard 483001 for ramp shoulder details.

Between Sections A-A and B-B (shaded area), provide a drainage swale and flush inlet to enhance drainage.

When using grades expressed in %, the grade value shall be divided by 100 to obtain vertical offsets.

When using radius R1 less than the minimum, verify the required acceleration length will be provided.

With a mainline horizontal curve to the left, keep the gore nose dimensions at Sections C-C and D-D as shown. From Section C-C to Section B-B, construct the ramp as a tangent section, and the gore nose at Section B-B shall be a variable width dependent on the radius of the mainline curve. Show a special cross-section on the plans for Section B-B.

With a mainline horizontal curve to the right, keep the gore nose dimensions at Sections D-D, C-C, and B-B as shown, and the edge of the ramp between Sections C-C and B-B is constructed as a compound curve tying Section C-C.

All dimensions are in inches (millimeters) unless otherwise shown.

DATE	REVISIONS
1-1-22	Revised General Note for joints and joint spacing.
1-1-18	Changed tie bar spacing to 36 (900) cts.

ENTRANCE RAMP TERMINAL
 (JOINTED PCC RAMP PAVEMENT ADJACENT TO JOINTED PCC MAINLINE PAVEMENT)

(Sheet 1 of 2)

STANDARD 420201-12

Illinois Department of Transportation

PASSED January 1, 2022
Michael Beard
 ENGINEER OF POLICY AND PROCEDURES

APPROVED January 1, 2022
John C. ...
 ENGINEER OF DESIGN AND ENVIRONMENT

ISSUED 1-1-97

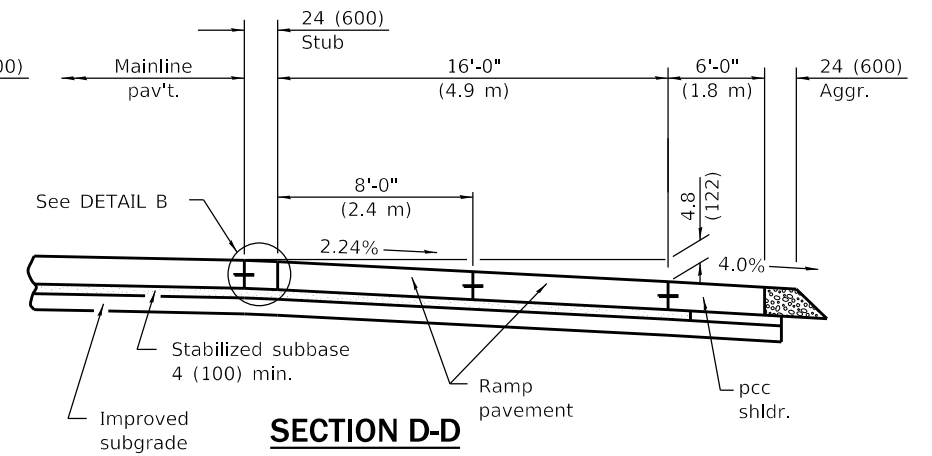
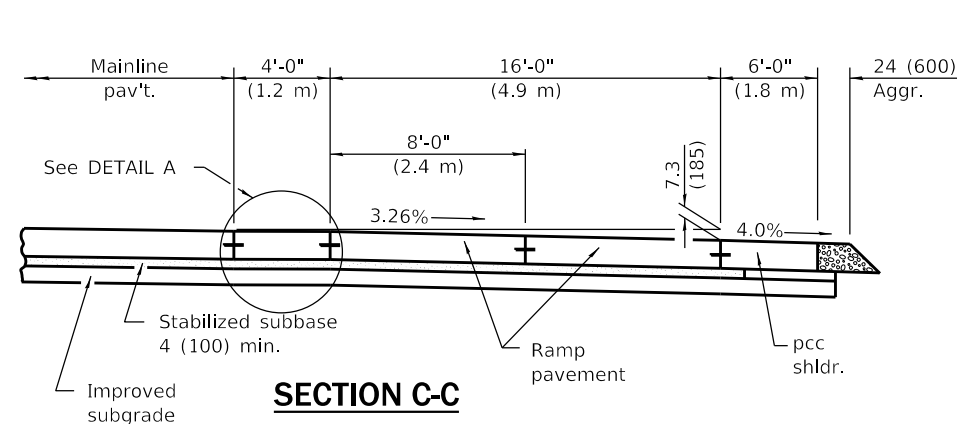
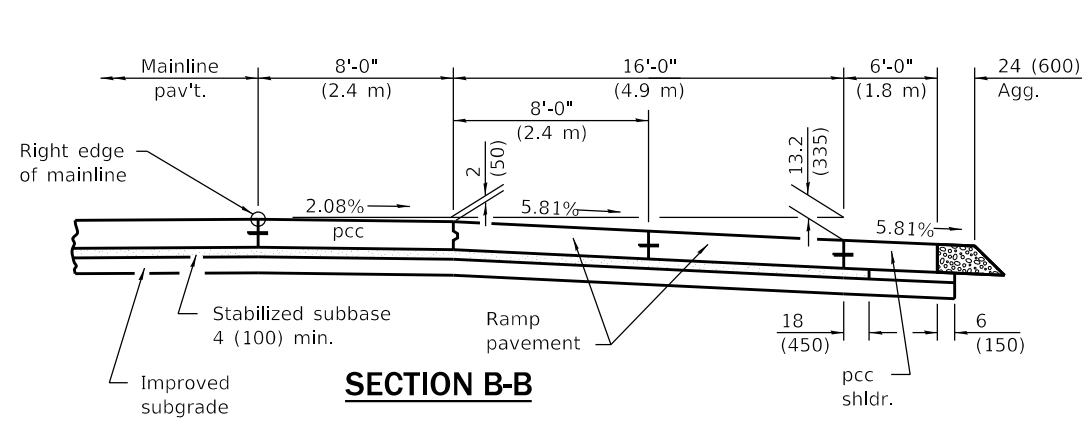

CROSS SECTIONS WHEN MAINLINE IS ON TANGENT OR CURVED TO THE RIGHT

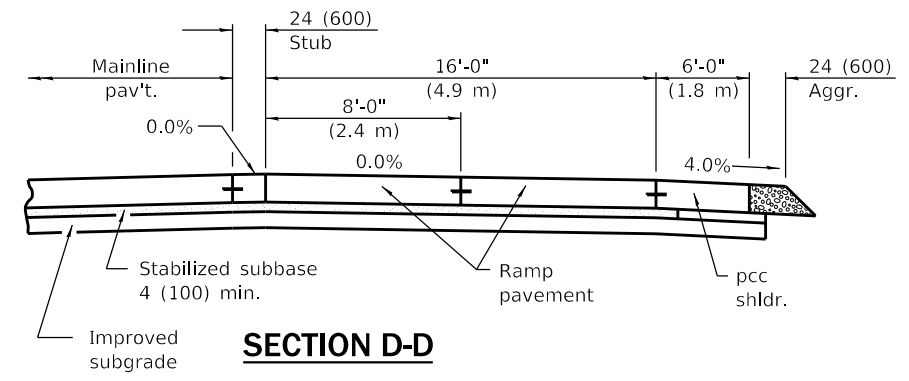
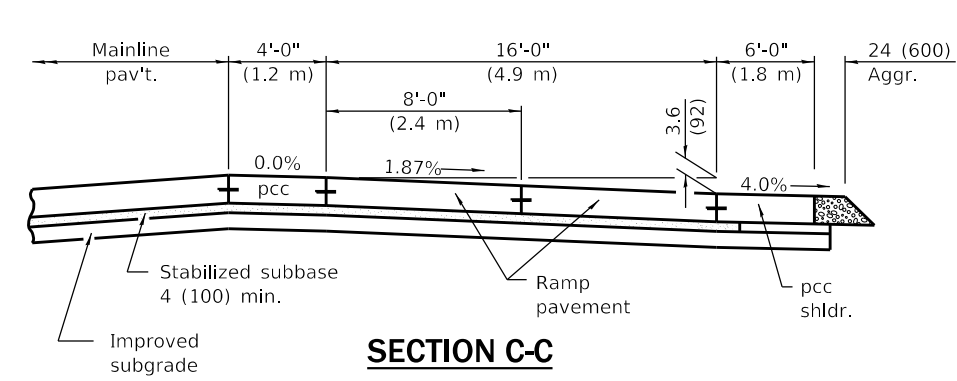
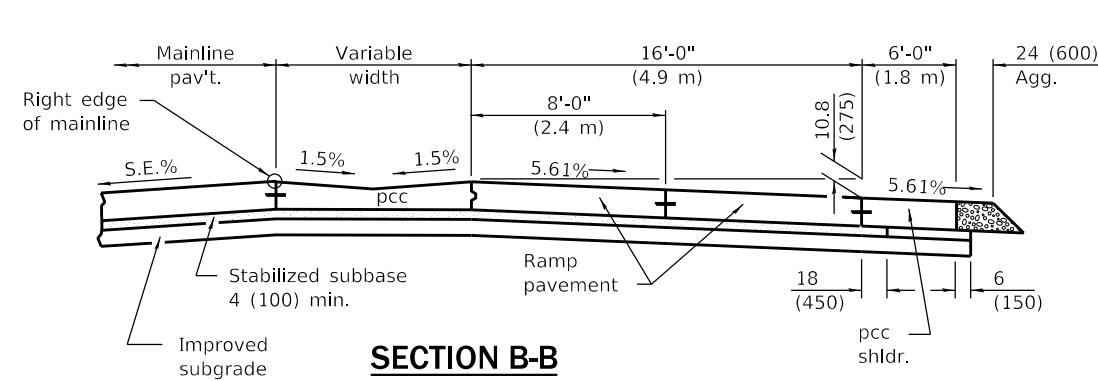

CROSS SECTIONS WHEN MAINLINE IS CURVED TO THE LEFT

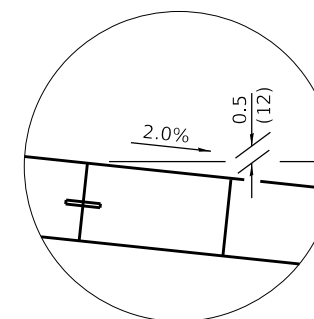
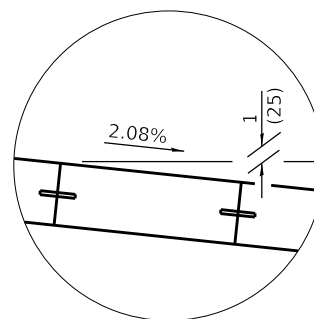

DETAIL A

DETAIL B

Illinois Department of Transportation

PASSED January 1, 2022
Michael Beard
 ENGINEER OF POLICY AND PROCEDURES

APPROVED January 1, 2022
John C. ...
 ENGINEER OF DESIGN AND ENVIRONMENT

ISSUED 1-1-97

ENTRANCE RAMP TERMINAL
 (JOINTED PCC RAMP PAVEMENT ADJACENT TO
 JOINTED PCC MAINLINE PAVEMENT)

(Sheet 2 of 2)

STANDARD 420201-12

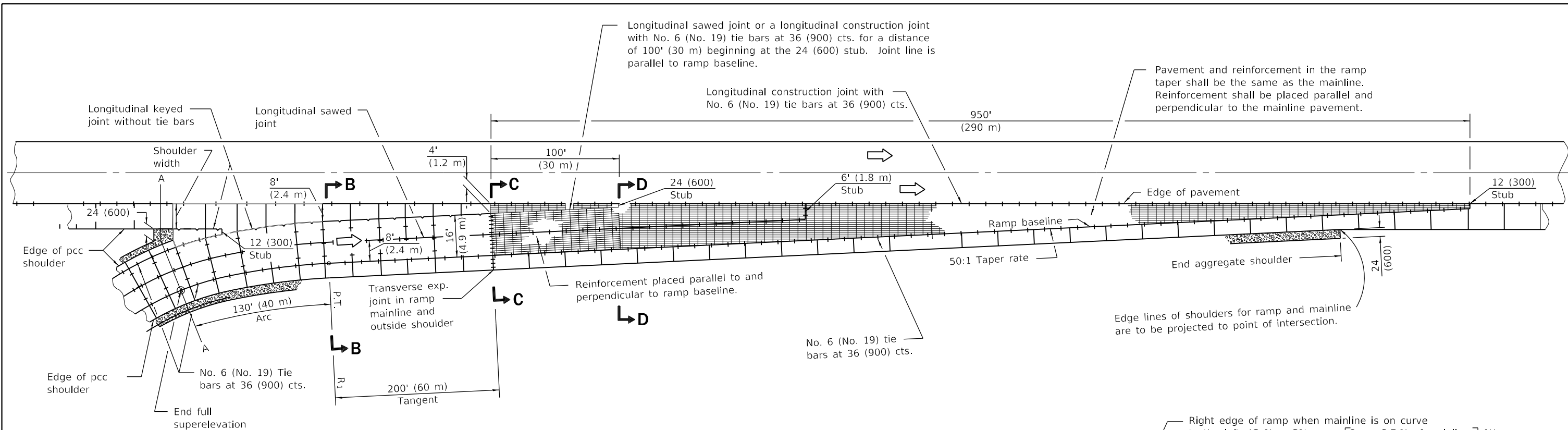

PLAN

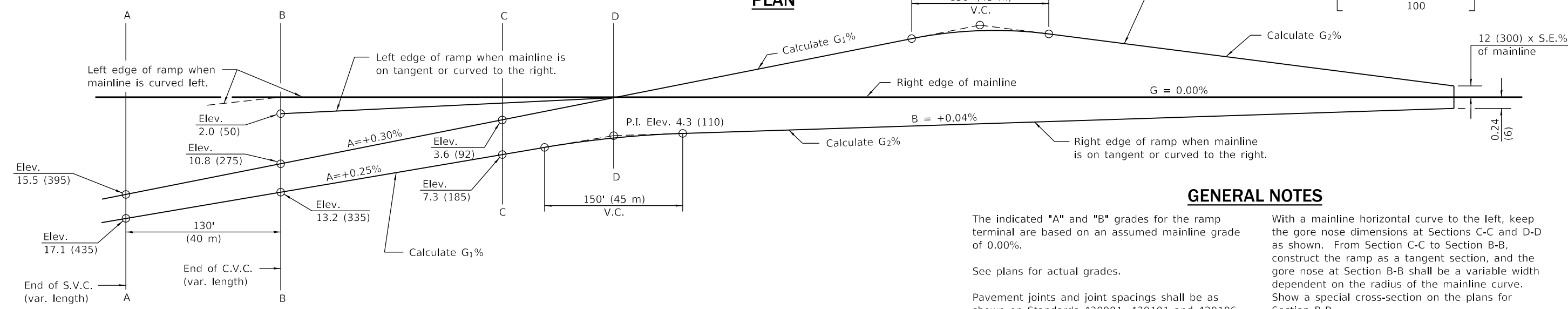

PROFILE

GENERAL NOTES

- The indicated "A" and "B" grades for the ramp terminal are based on an assumed mainline grade of 0.00%.
- See plans for actual grades.
- Pavement joints and joint spacings shall be as shown on Standards 420001, 420101 and 420106.
- See Standard 483001 for ramp shoulder details.
- Between Sections A-A and B-B (shaded area), provide a drainage swale and flush inlet to enhance drainage.
- When using grades expressed in %, the grade value shall be divided by 100 to obtain vertical offsets.
- When using a radius R1 less than the minimum, verify the required acceleration length will be provided.
- With a mainline horizontal curve to the left, keep the gore nose dimensions at Sections C-C and D-D as shown. From Section C-C to Section B-B, construct the ramp as a tangent section, and the gore nose at Section B-B shall be a variable width dependent on the radius of the mainline curve. Show a special cross-section on the plans for Section B-B.
- With a mainline horizontal curve to the right, keep the gore nose dimensions at Sections D-D, C-C, and B-B as shown, and the edge of the ramp between Sections C-C and B-B is constructed as a compound curve tying Section C-C.
- All dimensions are in inches (millimeters) unless otherwise shown.

DATE	REVISIONS
1-1-22	Revised General Note for joints and joint spacing.
1-1-18	Changed tie bar spacing to 36 (900) cts.

ENTRANCE RAMP TERMINAL
(JOINTED PCC RAMP PAVEMENT
ADJACENT TO CRC MAINLINE PAVEMENT)

(Sheet 1 of 2)

STANDARD 420206-13

Illinois Department of Transportation

PASSED January 1, 2022
Michael Beard
ENGINEER OF POLICY AND PROCEDURES

APPROVED January 1, 2022
John C. ...
ENGINEER OF DESIGN AND ENVIRONMENT

ISSUED 1-1-97

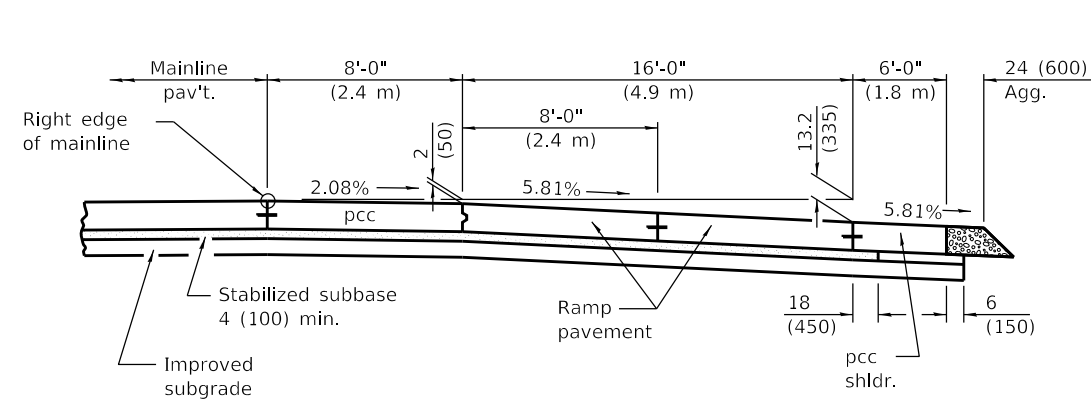

SECTION B-B

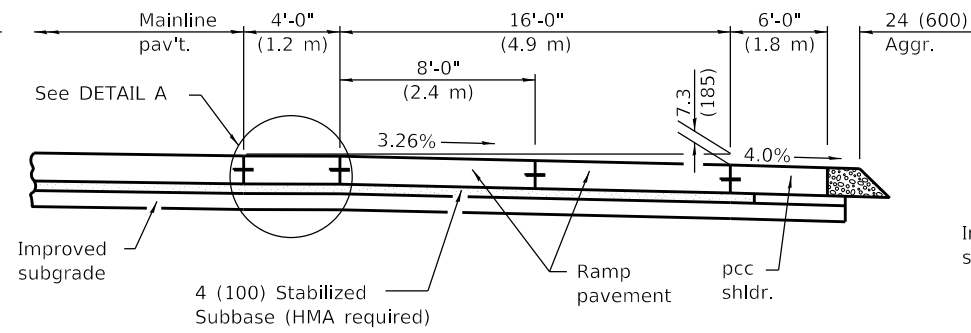

SECTION C-C

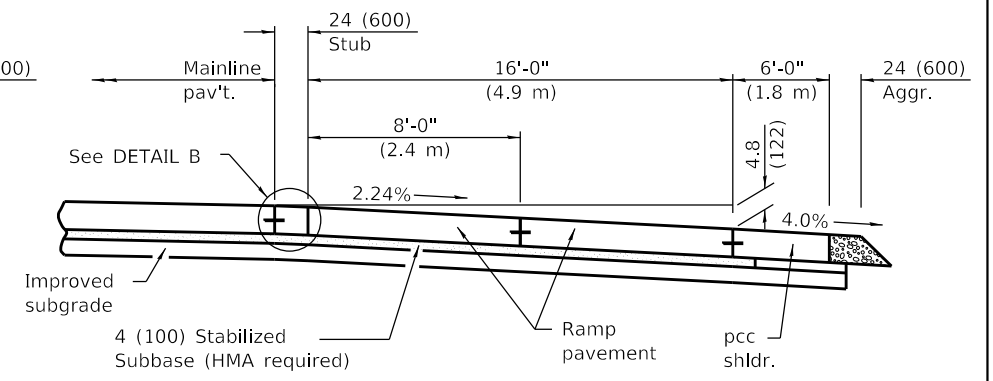

SECTION D-D

CROSS SECTIONS WHEN MAINLINE IS ON TANGENT OR CURVED TO THE RIGHT

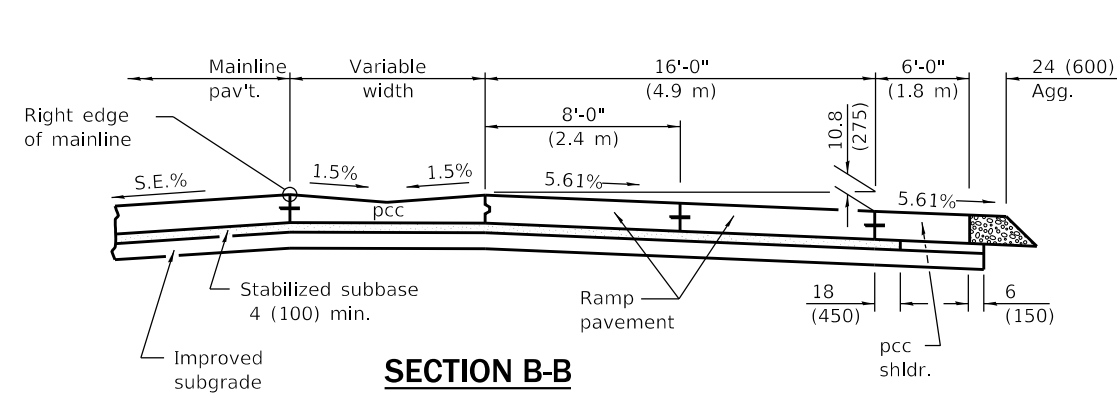

SECTION B-B

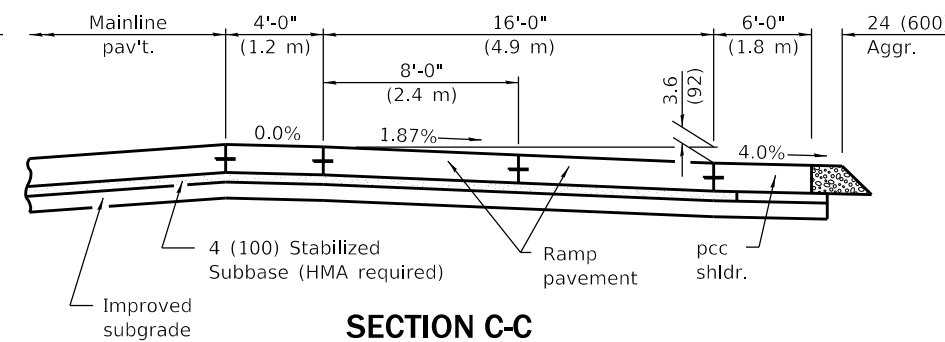

SECTION C-C

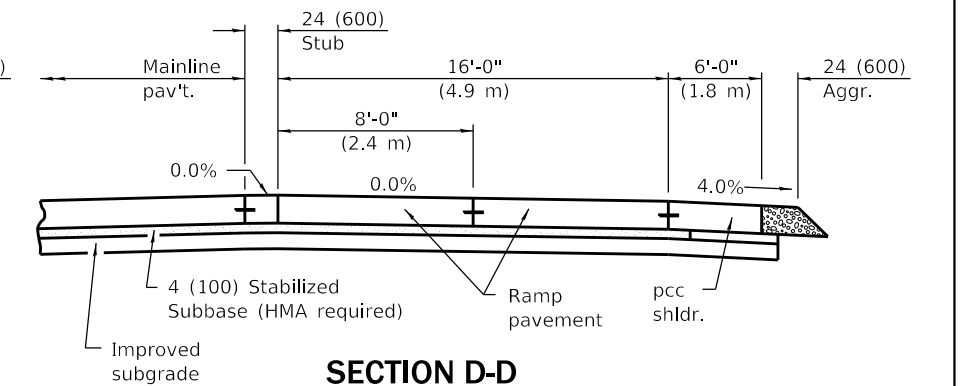

SECTION D-D

CROSS SECTIONS WHEN MAINLINE IS CURVED TO THE LEFT

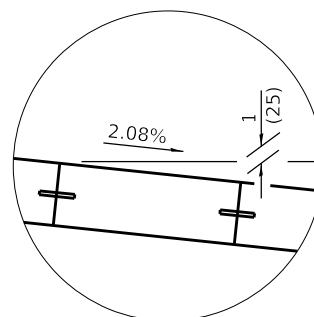

DETAIL A

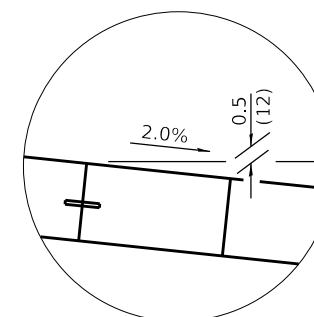

DETAIL B

Illinois Department of Transportation

PASSED January 1, 2022

Michael Beard
ENGINEER OF POLICY AND PROCEDURES

APPROVED January 1, 2022

John C. ...
ENGINEER OF DESIGN AND ENVIRONMENT

ISSUED 1-1-97

ENTRANCE RAMP TERMINAL
(JOINTED PCC RAMP PAVEMENT
ADJACENT TO CRC MAINLINE PAVEMENT)

(Sheet 2 of 2)

STANDARD 420206-13

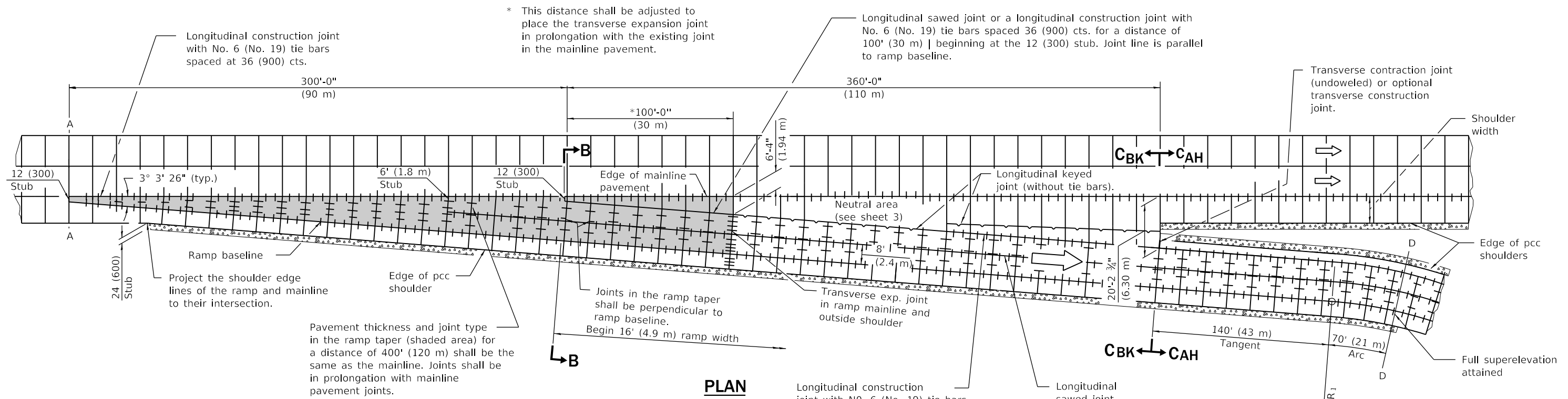

PLAN

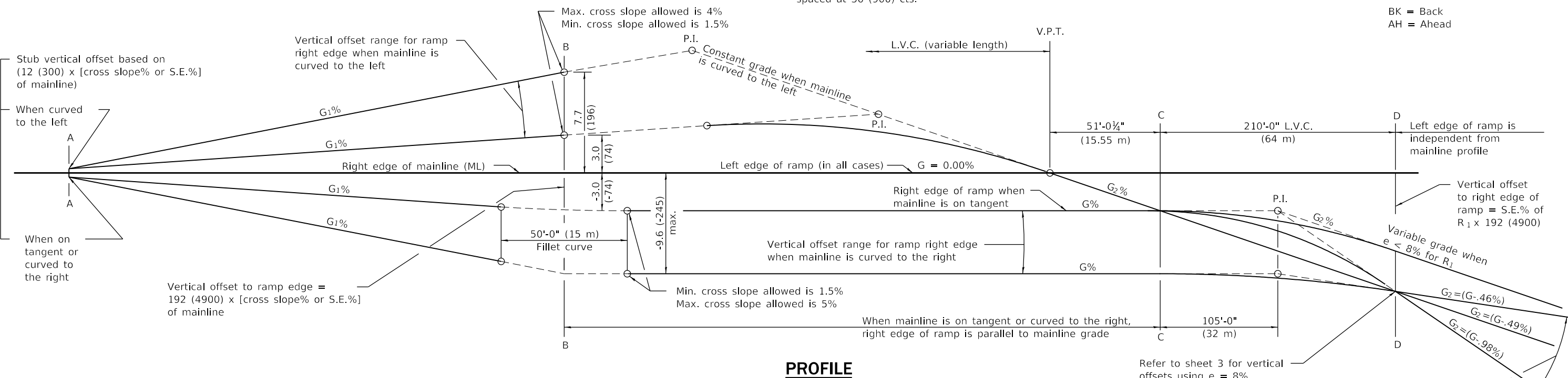

PROFILE

See Sheet 3 for GENERAL NOTES

Illinois Department of Transportation

PASSED January 1, 2022

Michael Beard
ENGINEER OF POLICY AND PROCEDURES

APPROVED January 1, 2022

John C. ...
ENGINEER OF DESIGN AND ENVIRONMENT

ISSUED 1-1-97

DATE	REVISIONS
1-1-22	Revised General Note for joints and joint spacings.
1-1-18	Changed tie bar spacing to 36 (900) cts.

EXIT RAMP TERMINAL
(JOINTED PCC RAMP PAVEMENT
ADJACENT TO JOINTED PCC MAINLINE PAVEMENT)

(Sheet 1 of 3)

STANDARD 420301-09

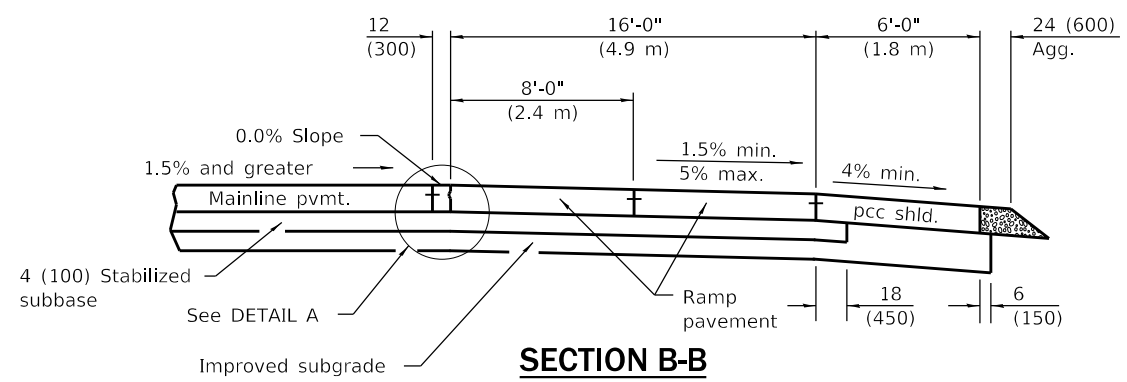

SECTION B-B

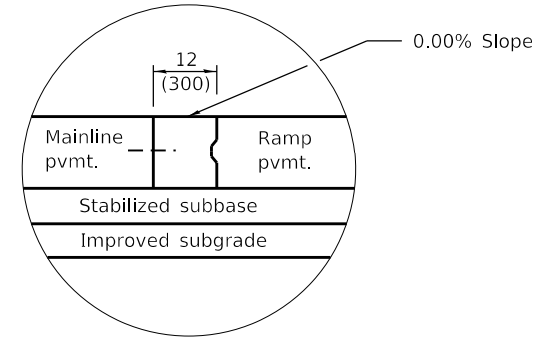

DETAIL A

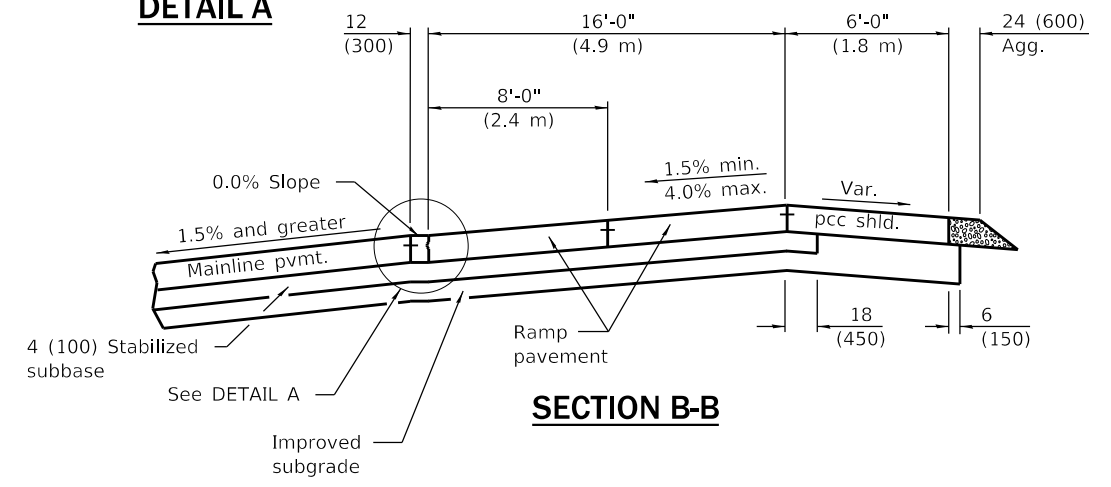

SECTION B-B

WHEN MAINLINE IS ON TANGENT OR CURVED TO THE RIGHT

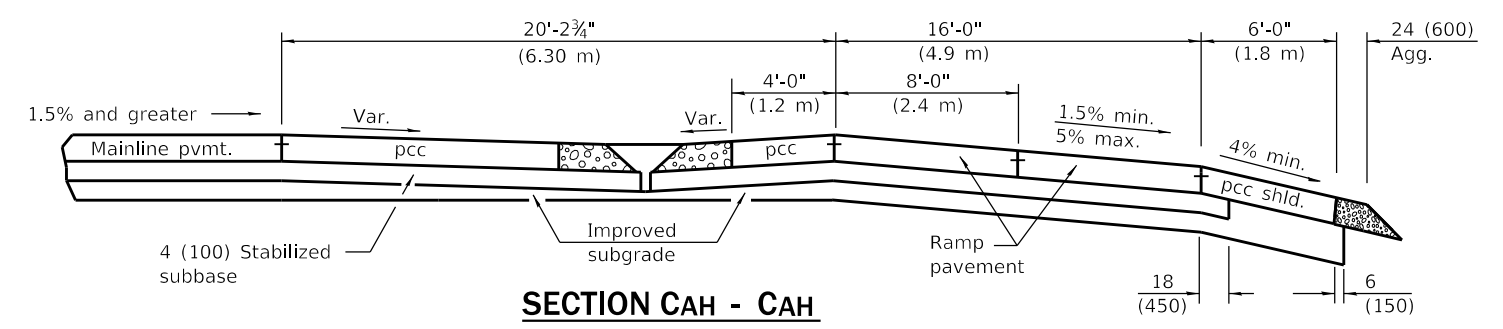

SECTION CAH - CAH

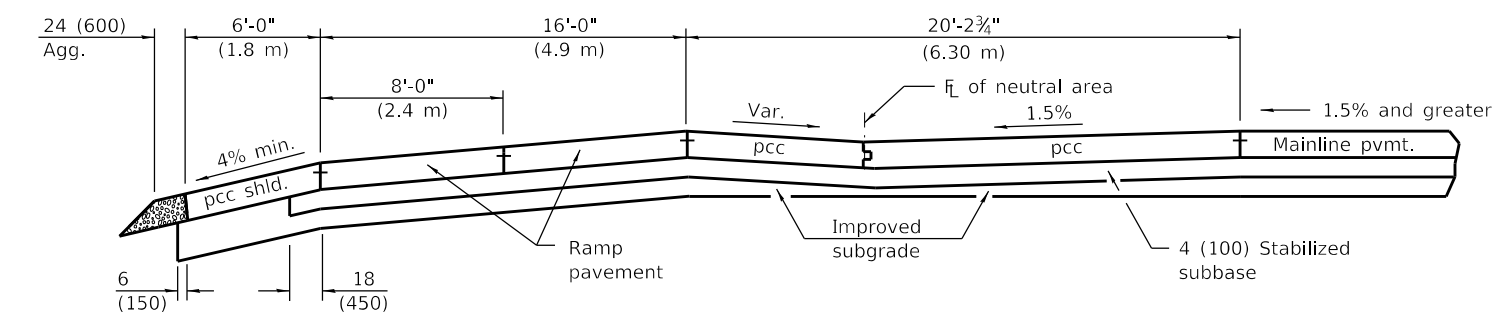

SECTION CBK - CBK

BK = Back
AH = Ahead

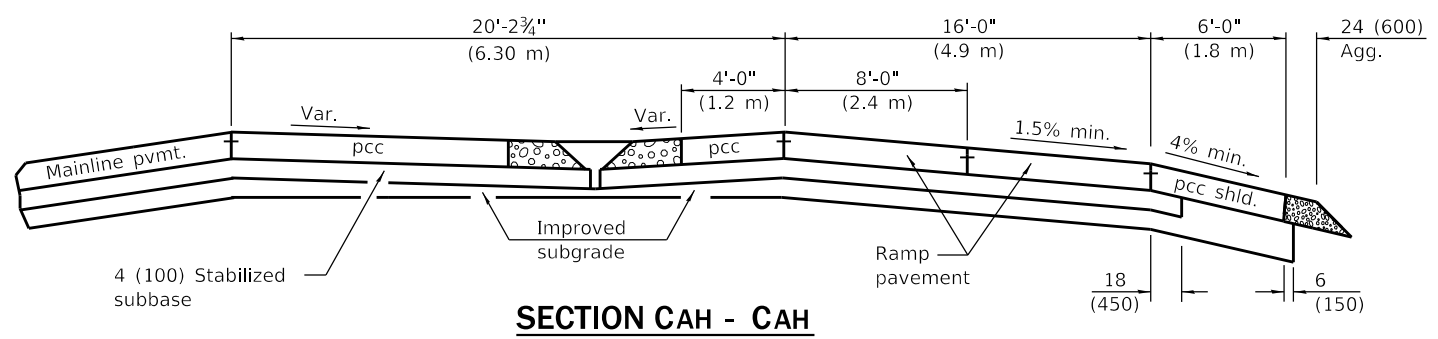

SECTION CAH - CAH

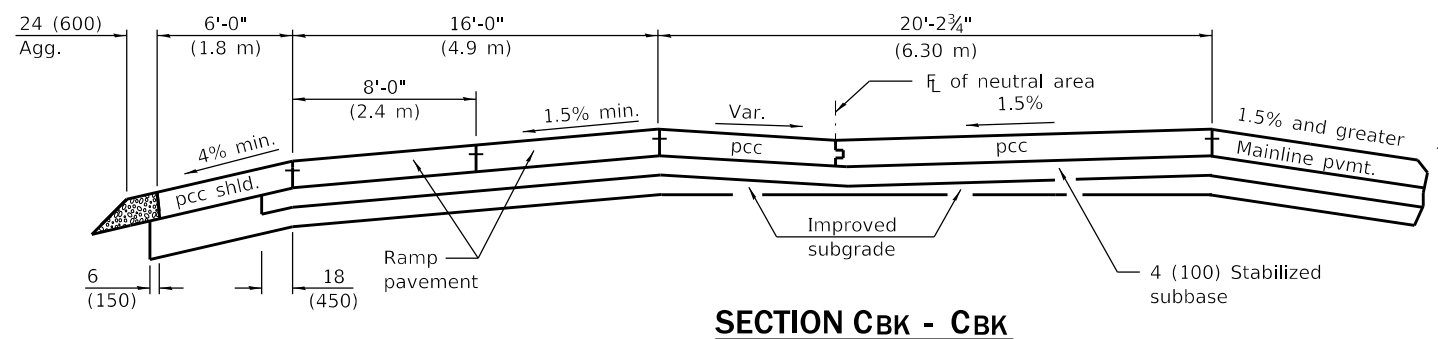

SECTION CBK - CBK

WHEN MAINLINE IS CURVED TO THE LEFT

See Sheet 3 for GENERAL NOTES

EXIT RAMP TERMINAL
(JOINTED PCC RAMP PAVEMENT
ADJACENT TO JOINTED PCC MAINLINE PAVEMENT)

(Sheet 2 of 3)

STANDARD 420301-09

Illinois Department of Transportation

PASSED January 1, 2022
Michael Beard
ENGINEER OF POLICY AND PROCEDURES

APPROVED January 1, 2022
John C. ...
ENGINEER OF DESIGN AND ENVIRONMENT

ISSUED 1-1-97

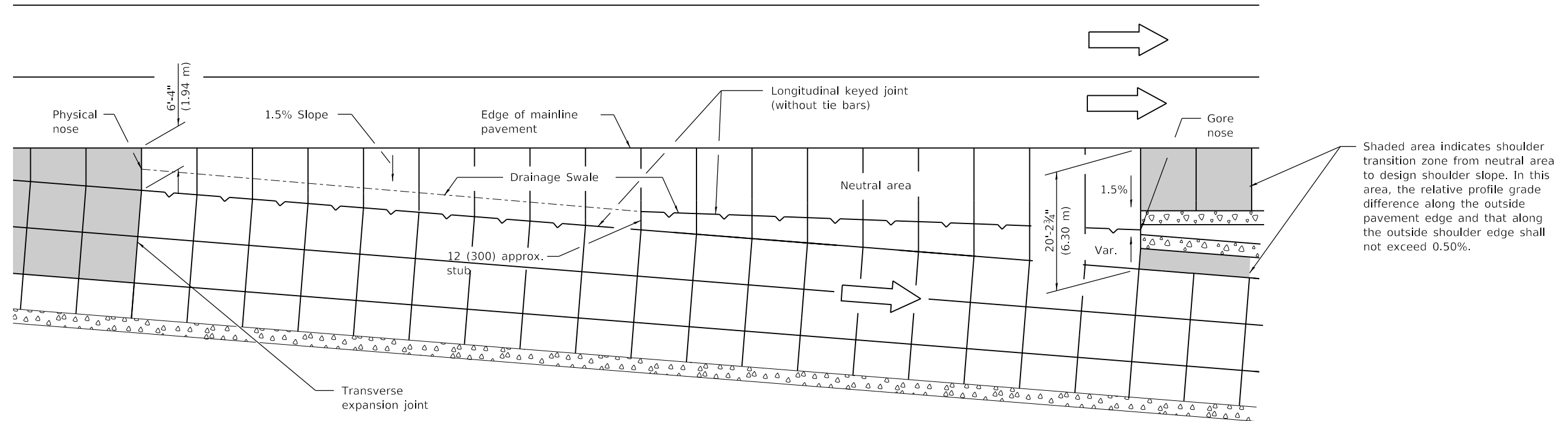

DETAILS FOR DRAINAGE IN NEUTRAL AREA

GENERAL NOTES

The initial ramp grade (G_2) is based on the line generated through the PI that is 105' (32 m) past Section C-C and the point created by the vertical offset at Section D-D.

See plans for actual grades.

Pavement joints and joint spacings shall be as shown on Standards 420001, 420101, and 420106.

See Standard 483001 for ramp shoulder details.

In the neutral area, provide a swale and flush inlet to enhance drainage.

When using grades expressed in %, the grade values shall be divided by 100 to obtain vertical offsets.

Where an exit ramp terminal is proposed adjacent to a mainline horizontal curve, construct the edge of the terminal by using offset widths, and for the terminal segment downstream from Section C-C to R_1 , construct the ramp as a 141' (43 m) tangent section.

All dimensions are in inches (millimeters) unless otherwise shown.

① Vertical offsets in inches for right edge of ramp, when $e = 8\%$

Sections	Mainline on Tangent	Mainline Curved Right	Mainline Curved Left
A	- 0.18	S.E. % ML x 12	S.E. % ML x 12 ②
B	- 3.0	S.E. % ML x 192	S.E. % ML x 192 ②
C	- 3.0	S.E. % ML x 192	- 3.0
D	- 15.4	- 15.4	- 15.4

① Vertical offsets in mm for right edge of ramp, when $e = 8\%$

Sections	Mainline on Tangent	Mainline Curved Right	Mainline Curved Left
A	- 5	S.E.% ML x 300	S.E.% ML x 300 ②
B	- 74	S.E.% ML x 4900	S.E.% ML x 4900 ②
C	- 74	S.E. % ML x 4900	- 74
D	- 392	- 392	- 392

- ① Vertical offset values are calculated and based on the right edge of mainline pavement at 0.0 % grade.
- ② The vertical offsets of these points are above the mainline pavement and lie on an upgrade in relationship to the mainline grade.
- ③ S.E.=Superelevation Rate

Illinois Department of Transportation

PASSED January 1, 2022
Michael Beard
 ENGINEER OF POLICY AND PROCEDURES

APPROVED January 1, 2022
Scott C. ...
 ENGINEER OF DESIGN AND ENVIRONMENT

ISSUED 1-1-97

EXIT RAMP TERMINAL
 (JOINTED PCC RAMP PAVEMENT
 ADJACENT TO JOINTED PCC MAINLINE PAVEMENT)

(Sheet 3 of 3)

STANDARD 420301-09

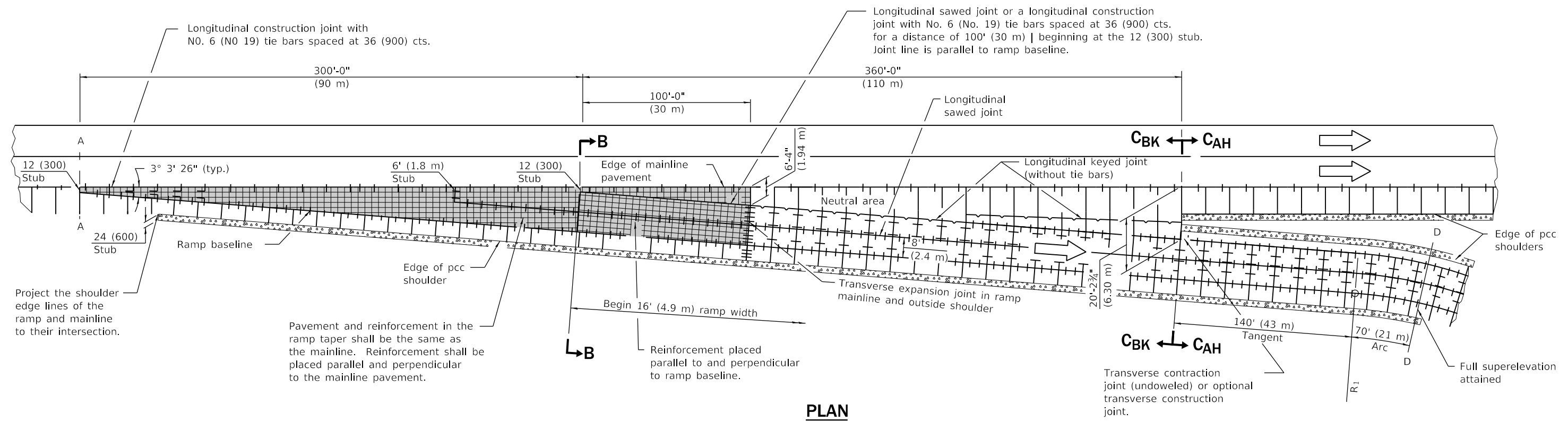

PLAN

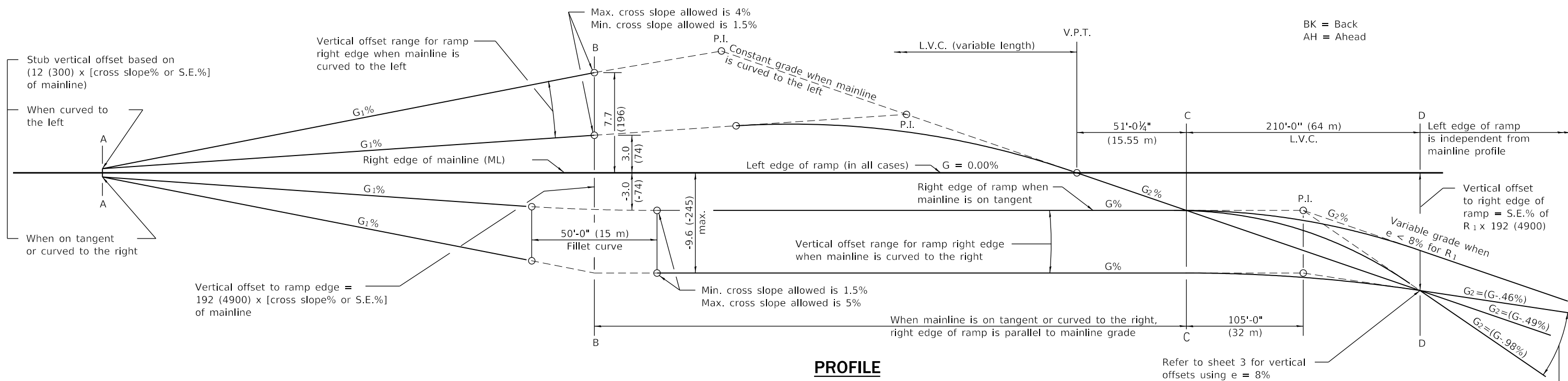

PROFILE

BK = Back
AH = Ahead

See Sheet 3 for GENERAL NOTES

Illinois Department of Transportation

PASSED January 1, 2022
Michael Beard
 ENGINEER OF POLICY AND PROCEDURES

APPROVED January 1, 2022
John C. ...
 ENGINEER OF DESIGN AND ENVIRONMENT

ISSUED 1-1-97

DATE	REVISIONS
1-1-22	Revised General Note for joints and joint spacing.
1-1-18	Changed spacing of tie bars to 36 (900) cts.

EXIT RAMP TERMINAL
 (JOINTED PCC RAMP PAVEMENT
 ADJACENT TO CRC MAINLINE PAVEMENT)

(Sheet 1 of 3)

STANDARD 420306-11

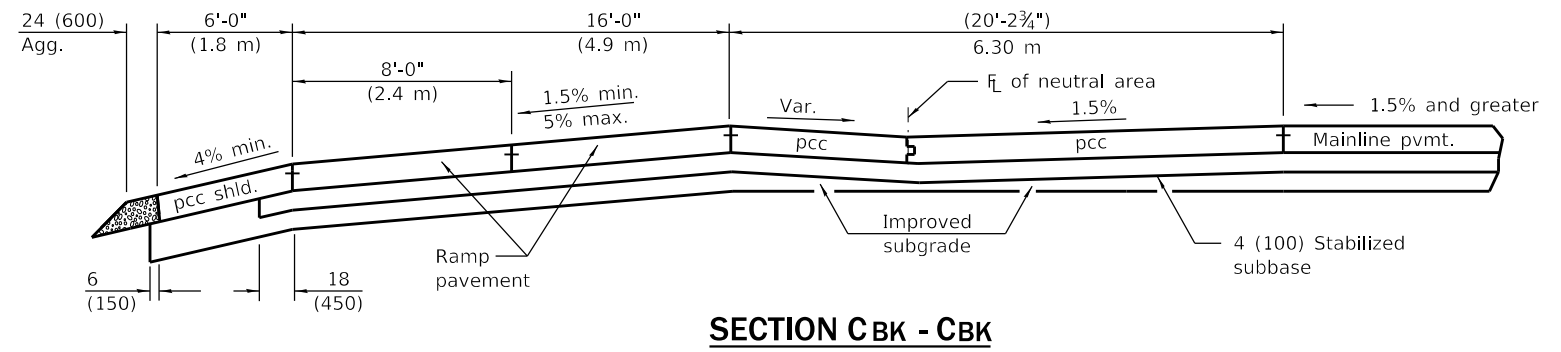
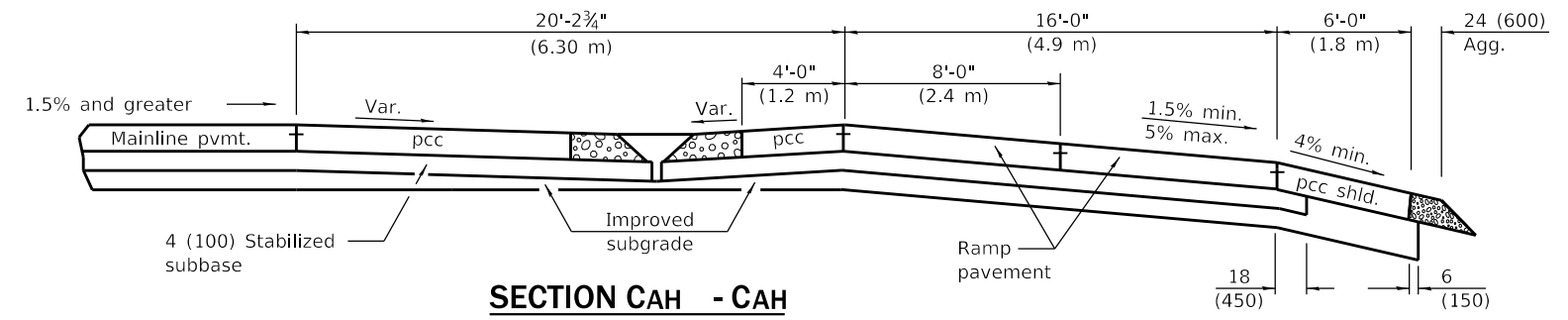
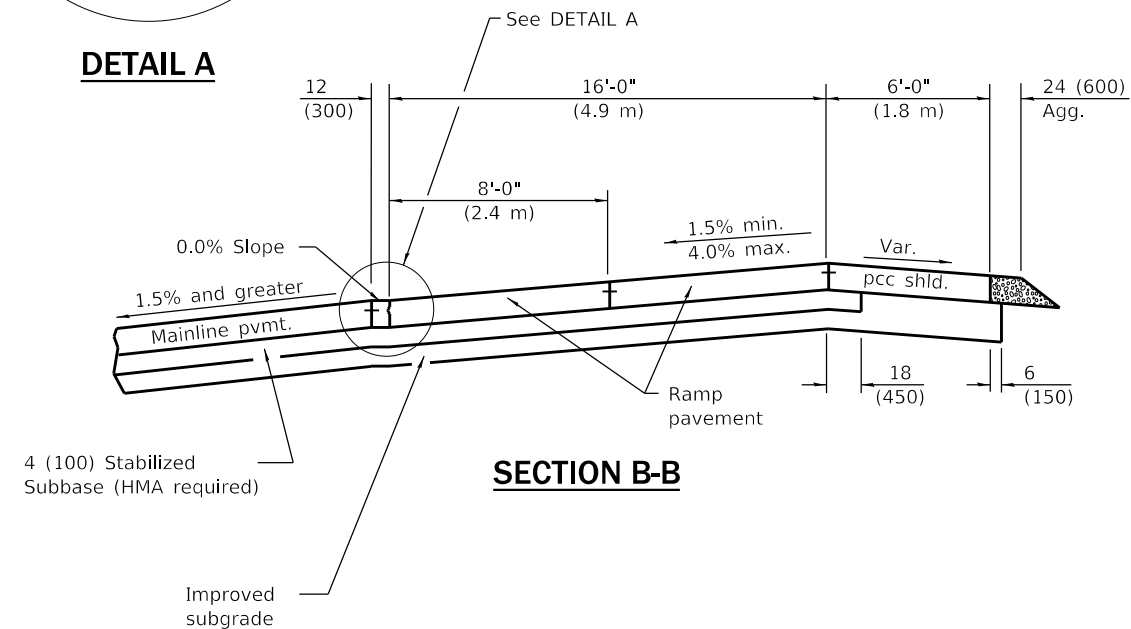
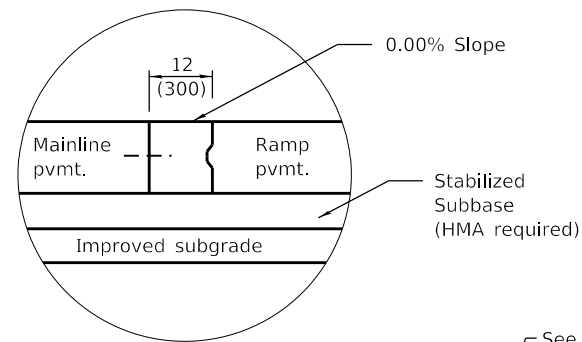
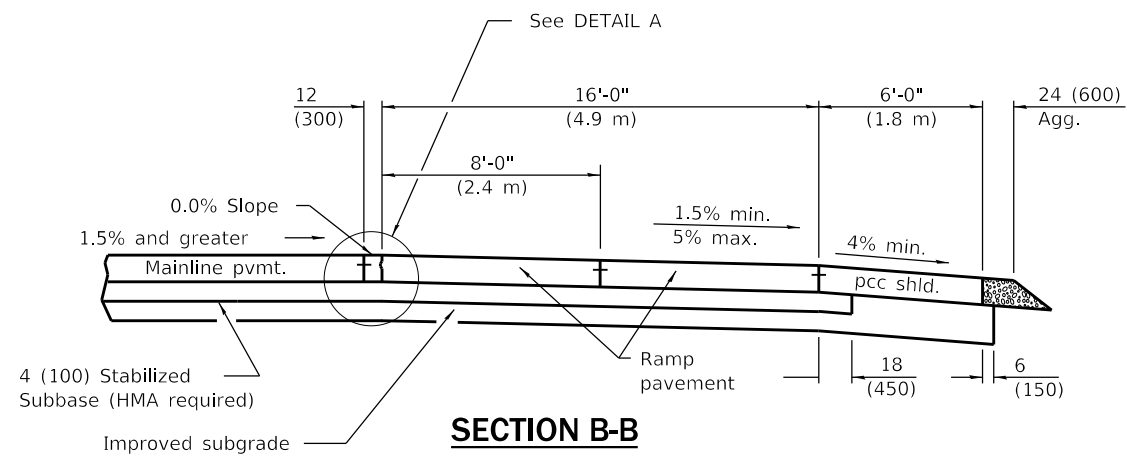

BK = Back
AH = Ahead

WHEN MAINLINE IS ON TANGENT OR CURVED TO THE RIGHT

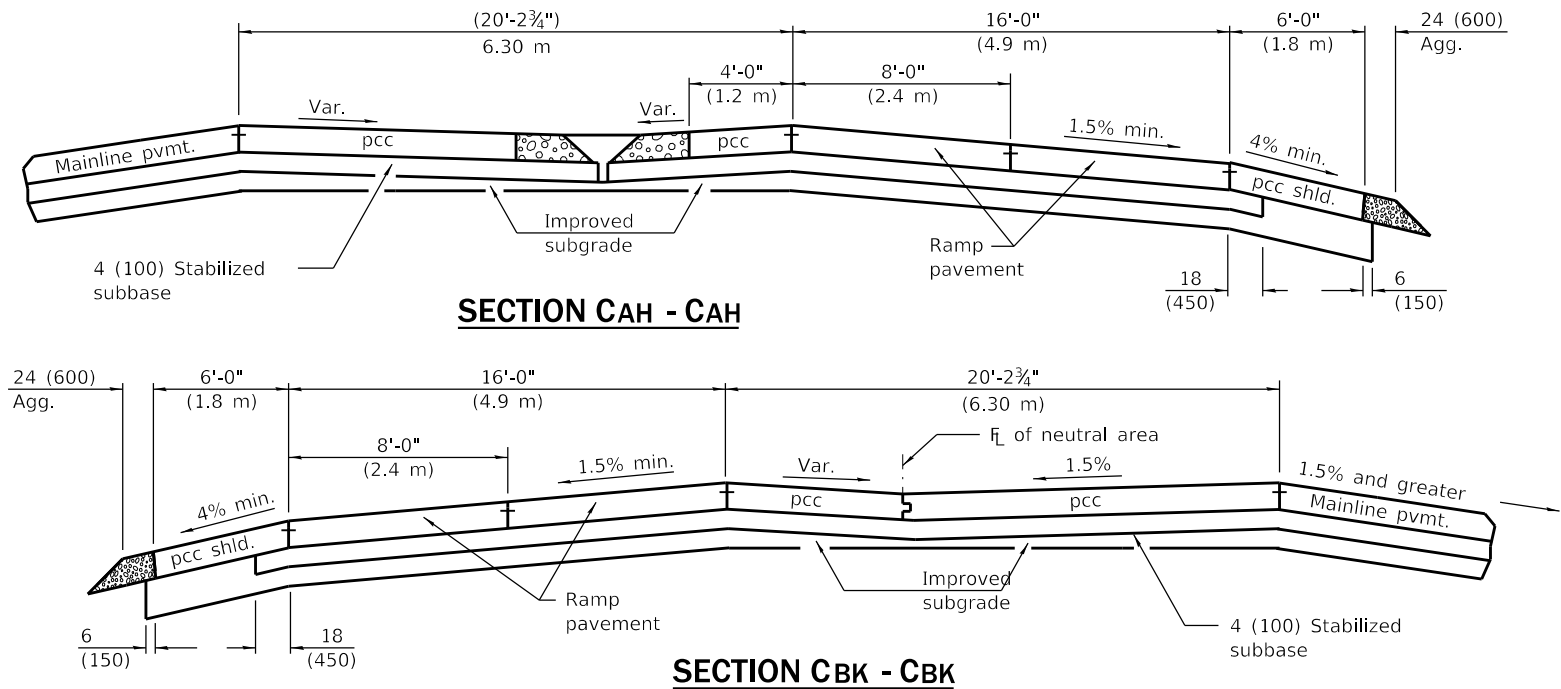

WHEN MAINLINE IS CURVED TO THE LEFT

See Sheet 3 for GENERAL NOTES

EXIT RAMP TERMINAL
(JOINTED PCC RAMP PAVEMENT
ADJACENT TO CRC MAINLINE PAVEMENT)

(Sheet 2 of 3)

STANDARD 420306-11

Illinois Department of Transportation

PASSED January 1, 2022
Michael Brand
ENGINEER OF POLICY AND PROCEDURES

APPROVED January 1, 2022
John C. ...
ENGINEER OF DESIGN AND ENVIRONMENT

ISSUED 1-1-97

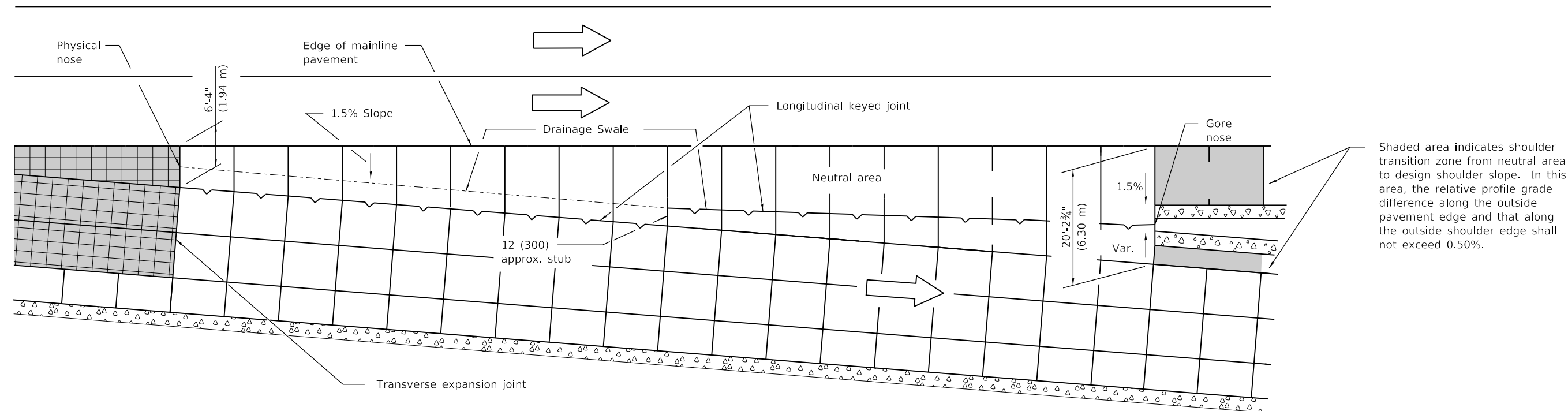

DETAILS FOR DRAINAGE IN NEUTRAL AREA

GENERAL NOTES

The initial ramp grade (G_2) is based on the line generated through the PI that is 105' (32 m) past Section C-C and the point created by the vertical offset at Section D-D.

See plans for actual grades.

Pavement joints and joint spacings shall be as shown on Standards 420001, 420101, and 420106.

See Standard 483001 for ramp shoulder details.

In the neutral area, provide a swale and flush inlet to enhance drainage.

When using grades expressed in %, the grade values shall be divided by 100 to obtain vertical offsets.

Where an exit ramp terminal is proposed adjacent to a mainline horizontal curve, construct the edge of the terminal by using offset widths, and for the terminal segment downstream from Section C-C to R_1 , construct the ramp as a 141' (43 m) tangent section.

All dimensions are in inches (millimeters) unless otherwise shown.

① Vertical offsets in inches for right edge of ramp, when $e = 8\%$

Sections	Mainline on Tangent	Mainline Curved Right	Mainline Curved Left
A	- 0.18	S.E. % ML x 12	S.E. % ML x 12 ②
B	- 3.0	S.E. % ML x 192	S.E. % ML x 192 ②
C	- 3.0	S.E. % ML x 192	- 3.0
D	- 15.4	- 15.4	- 15.4

① Vertical offsets in mm for right edge of ramp, when $e = 8\%$

Sections	Mainline on Tangent	Mainline Curved Right	Mainline Curved Left
A	- 5	S.E.% ML x 300	S.E.% ML x 300 ②
B	- 74	S.E.% ML x 4900	S.E.% ML x 4900 ②
C	- 74	S.E. % ML x 4900	- 74
D	- 392	- 392	- 392

- ① Vertical offset values are calculated and based on the right edge of mainline pavement at 0.0 % grade.
- ② The vertical offsets of these points are above the mainline pavement and lie on an upgrade in relationship to the mainline grade.
- ③ S.E.=Superelevation Rate

Illinois Department of Transportation

PASSED January 1, 2022
Michael Beard
 ENGINEER OF POLICY AND PROCEDURES

APPROVED January 1, 2022
Scott C. ...
 ENGINEER OF DESIGN AND ENVIRONMENT

ISSUED 1-1-97

EXIT RAMP TERMINAL
 (JOINTED PCC RAMP PAVEMENT
 ADJACENT TO CRC MAINLINE PAVEMENT)

(Sheet 3 of 3)

STANDARD 420306-11

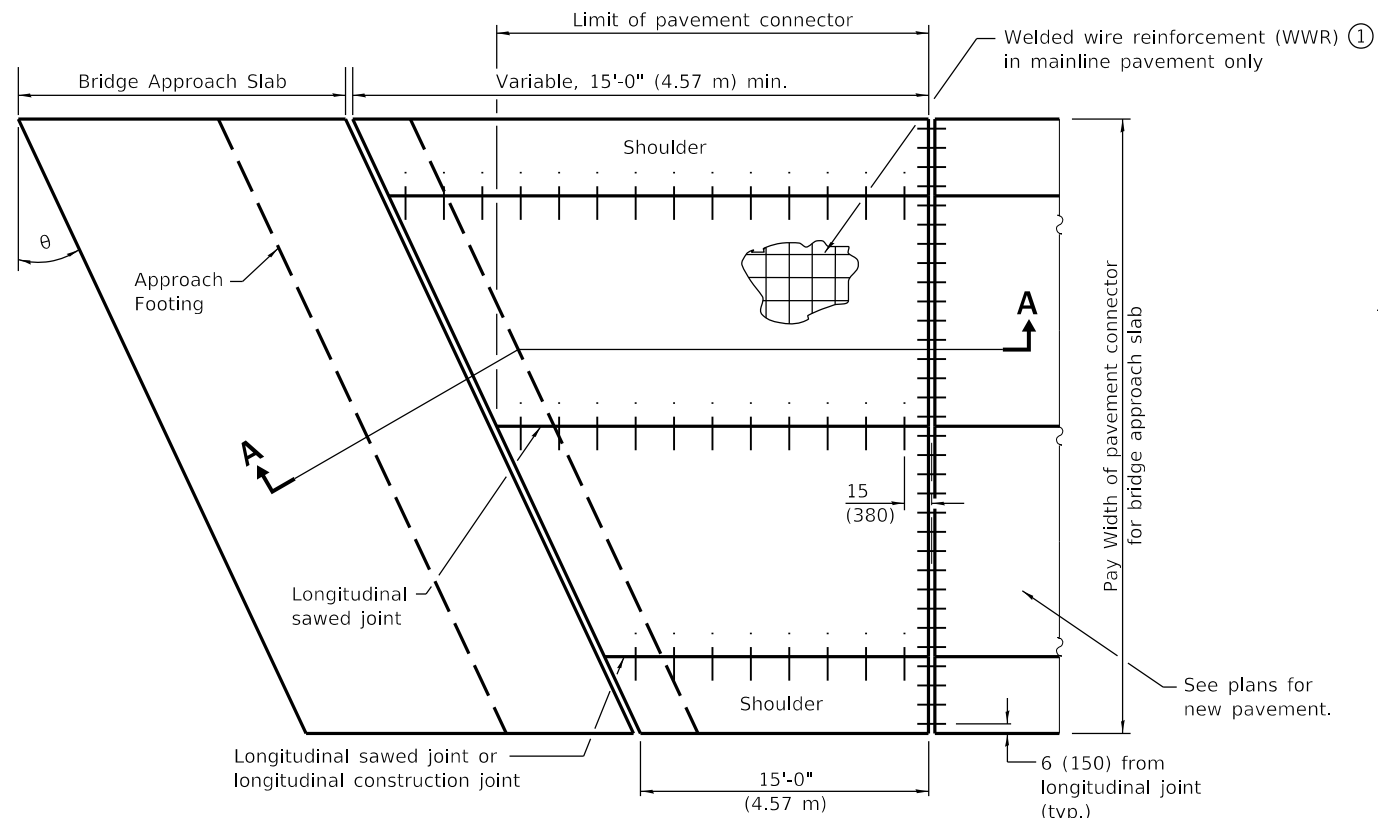

**PLAN
NEW CONSTRUCTION**

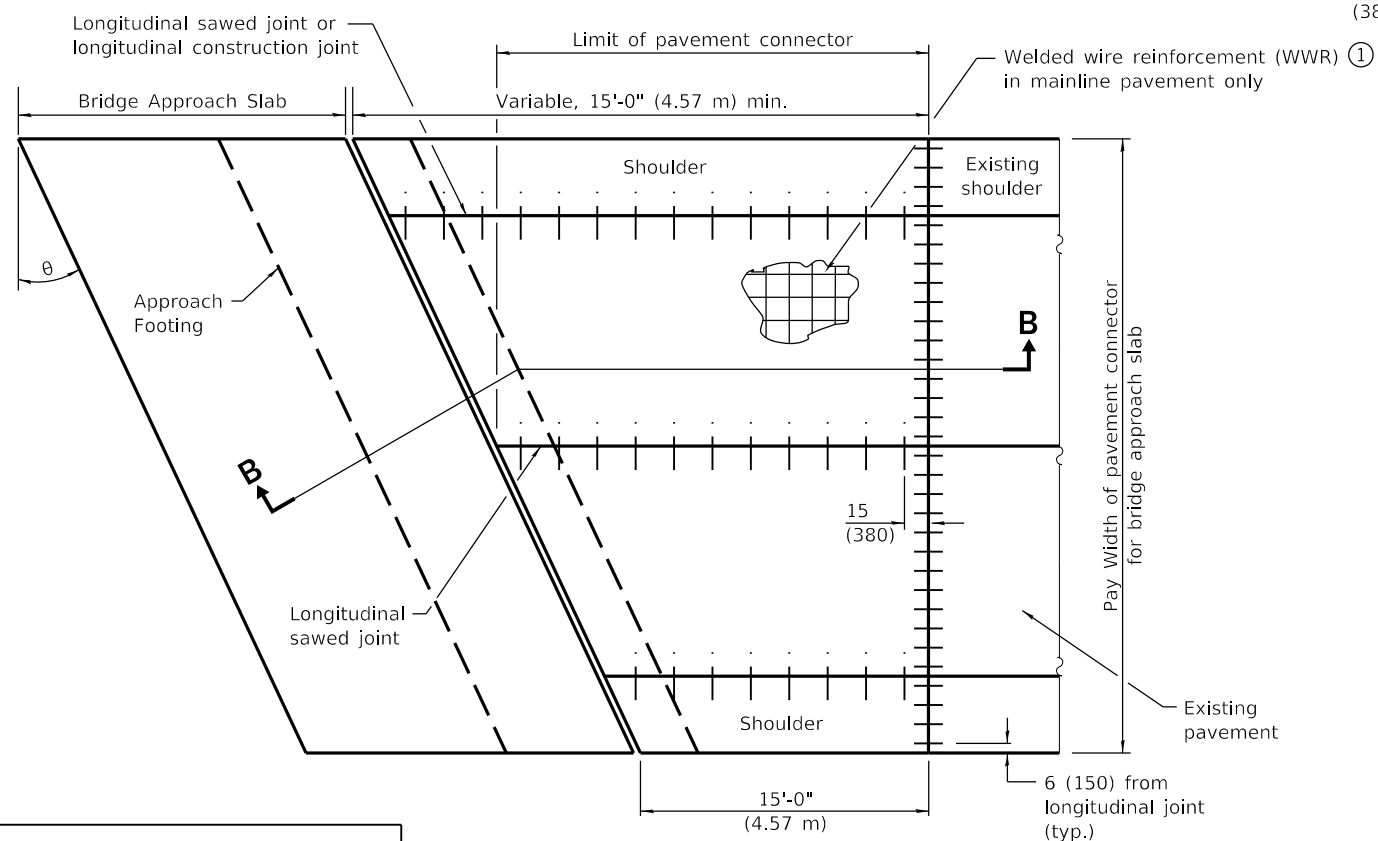

**PLAN
EXISTING CONSTRUCTION**

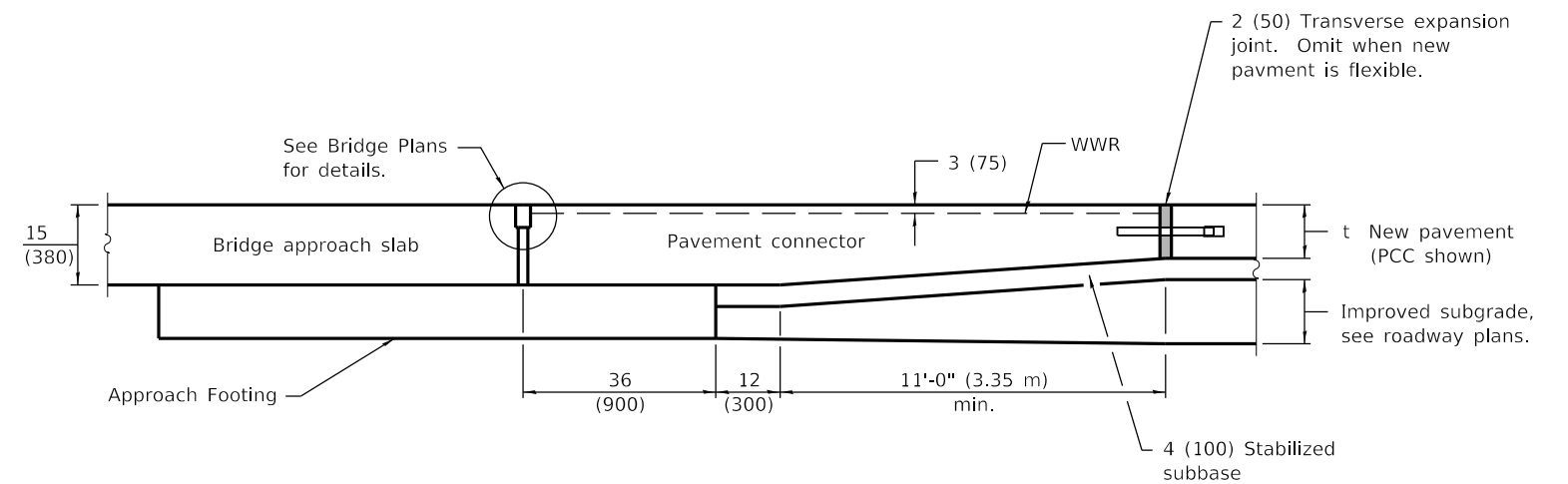

SECTION A-A

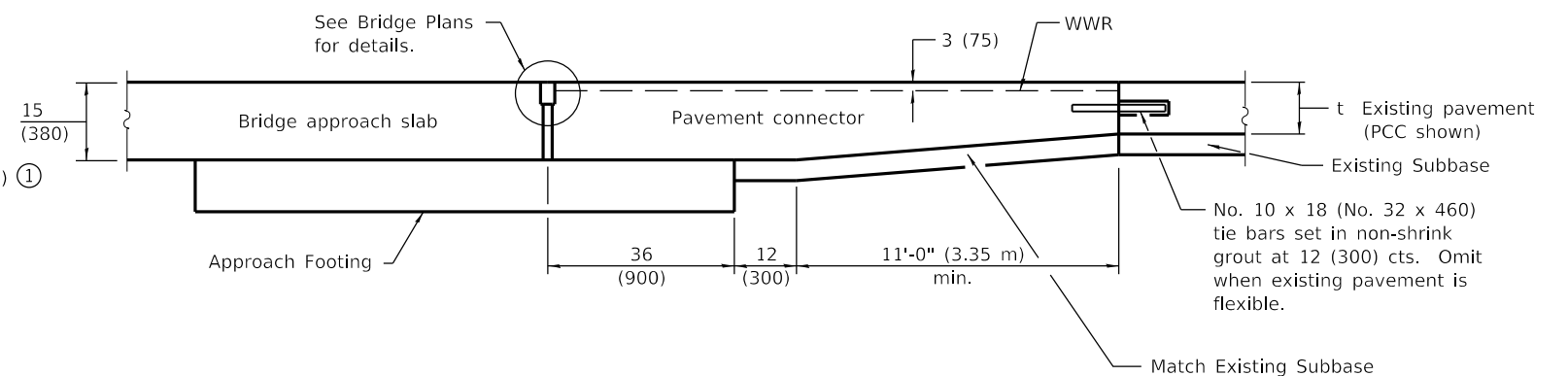

SECTION B-B

① WWR shall be 0.11 sq. in./ft. (230 sq. mm/m) in both directions. Maximum wire spacing shall be 6 (150). Minimum lap distance shall be two cross wires.

GENERAL NOTES

- THICKNESS-*t*=Thickness of Pavement.
- See Standard 420001 for pavement joint details not shown.
- See Standard 610001 for shoulder inlet with curb when required.
- See plans for details of bridge approach slab, approach footing and joint treatment.
- All dimensions are in inches (millimeters) unless otherwise shown.

DATE	REVISIONS
1-1-19	Changed rebar in pavement connector to welded wire reinforcement.
4-1-16	Revised pavement connector to be rigid only. Omitted WFB term. joint. Renamed std.

**PAVEMENT CONNECTOR (PCC)
FOR BRIDGE APPROACH SLAB**

STANDARD 420401-13

Illinois Department of Transportation

PASSED January 1 2019
Michael Bond
 ENGINEER OF POLICY AND PROCEDURES

APPROVED January 1 2019
John E. ...
 ENGINEER OF DESIGN AND ENVIRONMENT

ISSUED 1-1-97

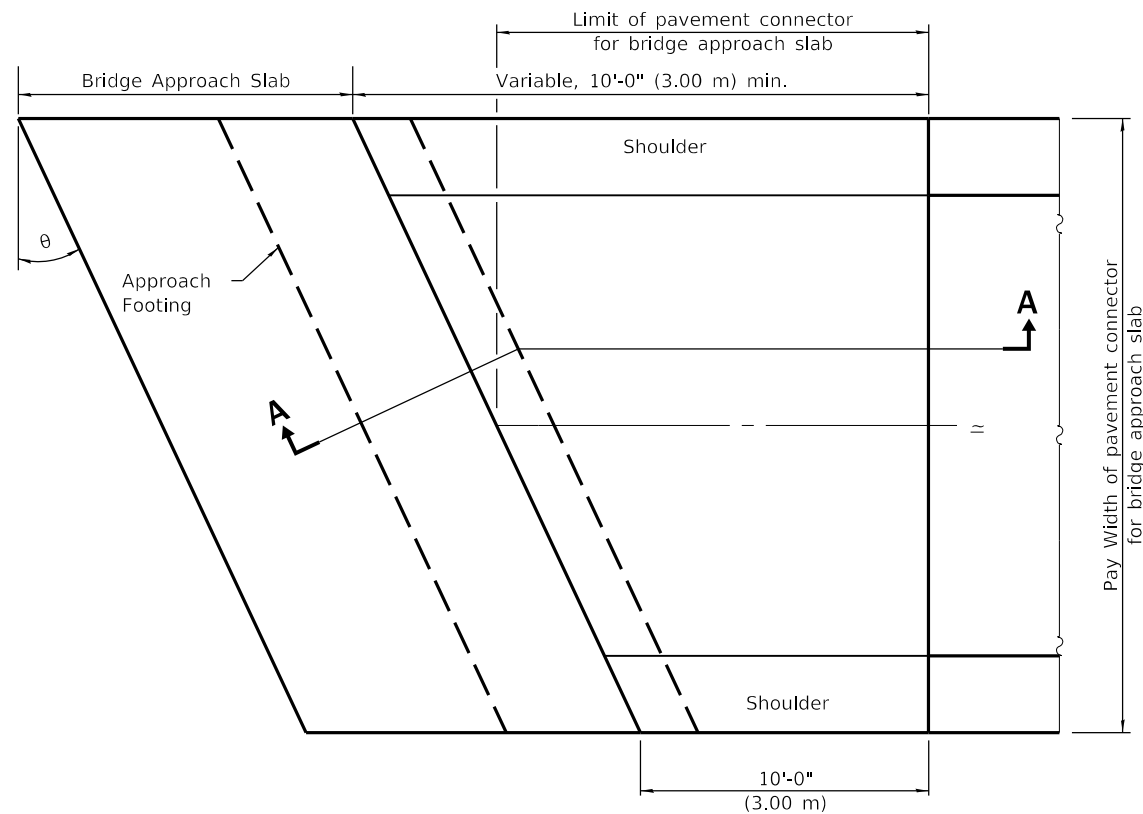

PLAN
(New or existing construction)

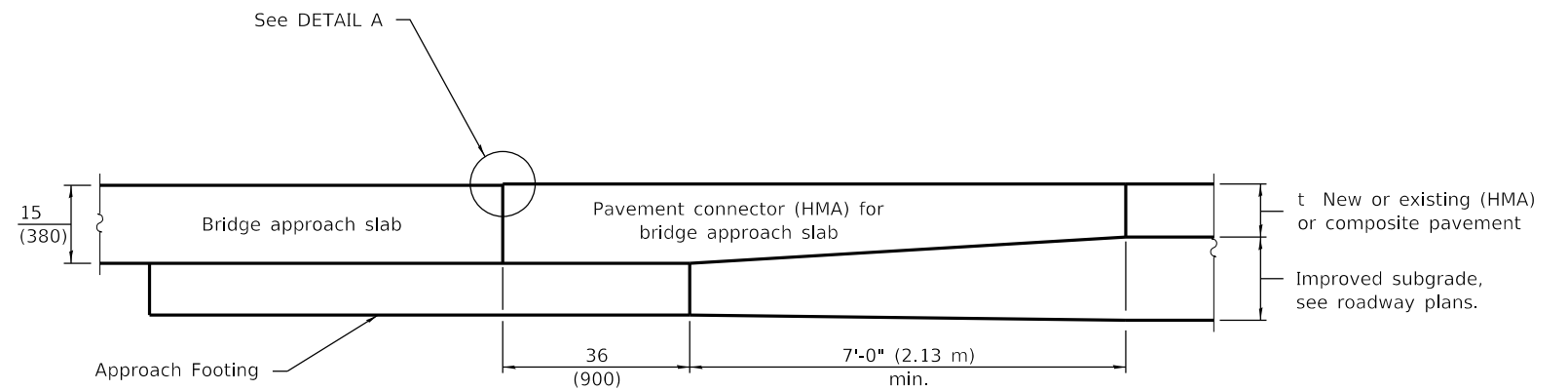

SECTION A-A

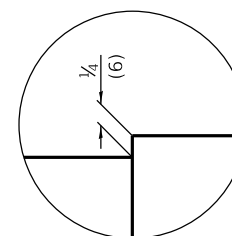

DETAIL A

GENERAL NOTES

THICKNESS-*t*=Thickness of Pavement.

See Standard 610001 for shoulder inlet with curb when required.

See plans for details of bridge approach slab and approach footing.

All dimensions are in inches (millimeters) unless otherwise shown.

DATE	REVISIONS
4-1-16	New standard.

**PAVEMENT CONNECTOR (HMA)
FOR BRIDGE APPROACH SLAB**

STANDARD 420406

Illinois Department of Transportation

PASSED April 1, 2016
Michael Beard
ENGINEER OF POLICY AND PROCEDURES

APPROVED April 1, 2016
[Signature]
ENGINEER OF DESIGN AND ENVIRONMENT

ISSUED 1-1-97

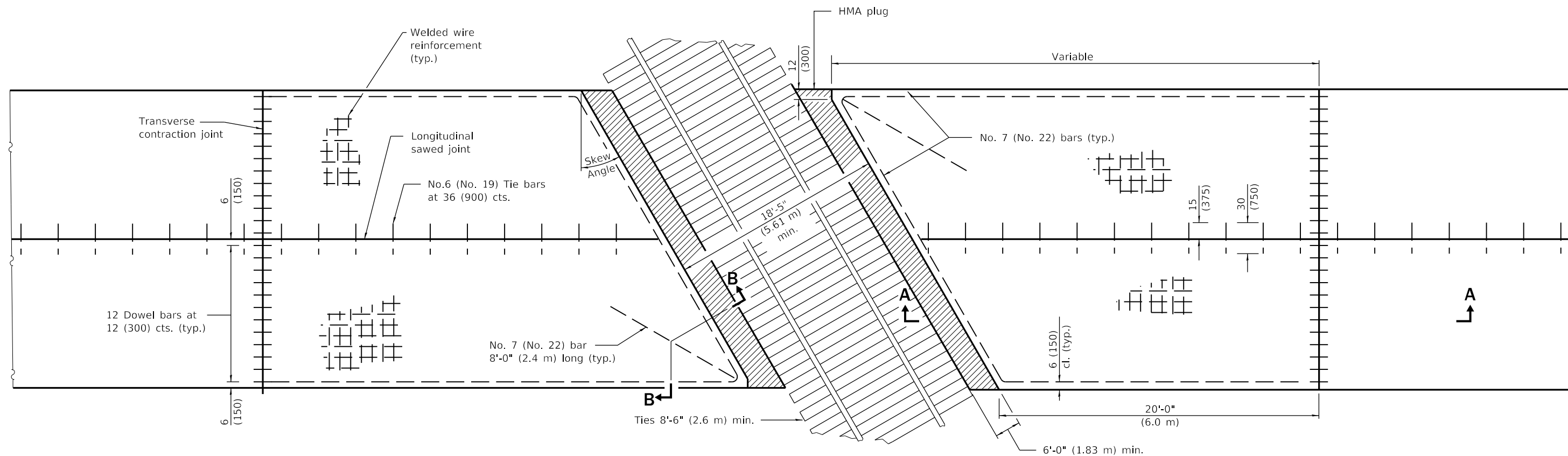

PLAN

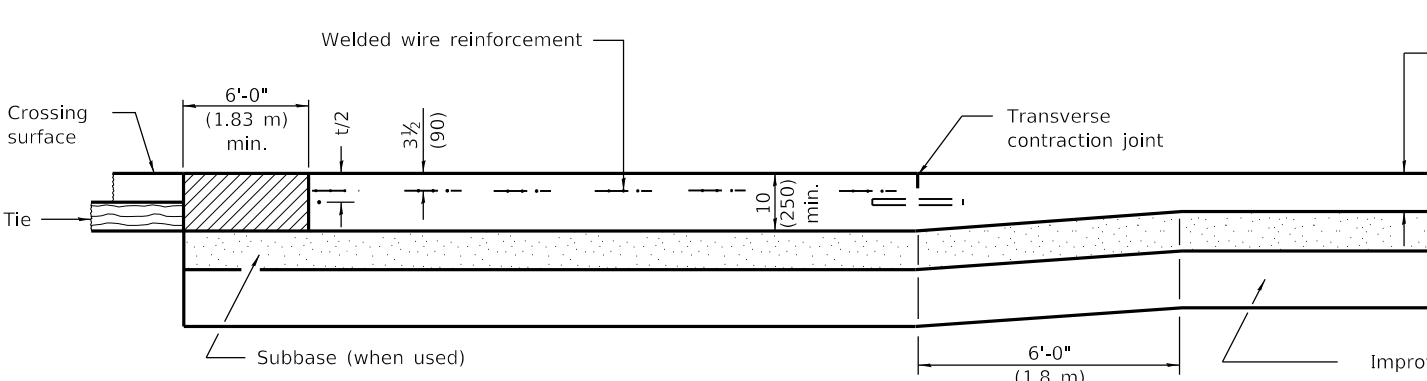

SECTION A-A
(FOR PCC PAVEMENT)

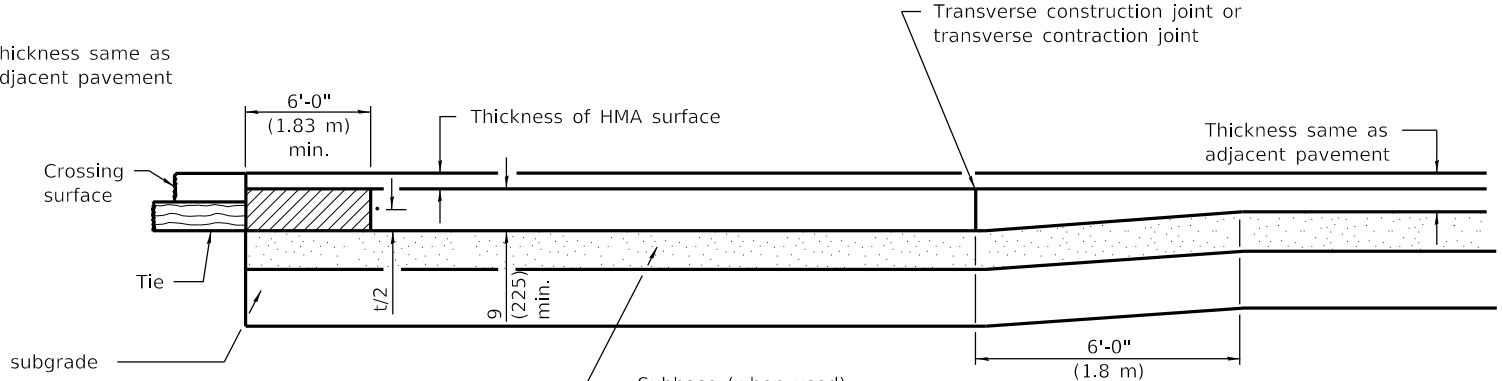

SECTION A-A
(FOR PCC BASE COURSE WITH HMA SURFACE)

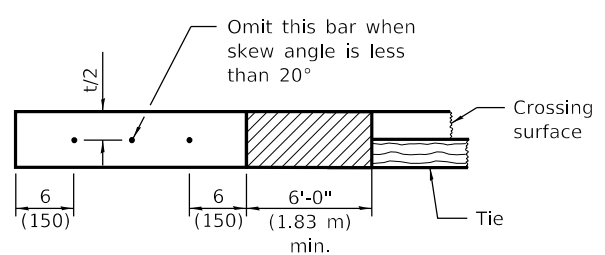

SECTION B-B

GENERAL NOTES

See Standard 420001 for joint details not shown.
All dimensions are in inches (millimeters) unless otherwise shown.

DATE	REVISIONS
1-1-18	Revised standard to reflect change of tie bar spacing to 36 (900) cts.
4-1-16	Changed terminology to 'welded wire reinforcement'.

PCC PAVEMENT AND PCC BASE COURSE ADJACENT TO RAILROAD GRADE CROSSING

STANDARD 420501-07

Illinois Department of Transportation

PASSED January 1, 2018
Michael Beard
ENGINEER OF POLICY AND PROCEDURES

APPROVED January 1, 2018
Maureen M. Beck
ENGINEER OF DESIGN AND ENVIRONMENT

ISSUED 1-1-97

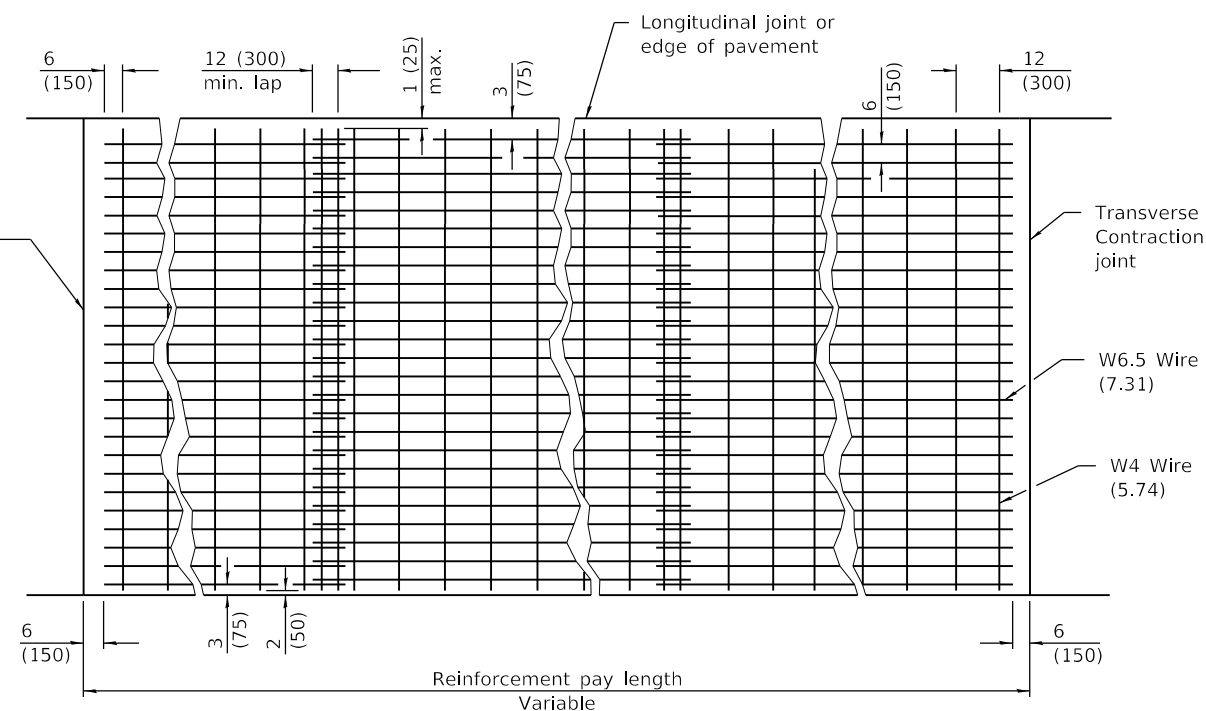
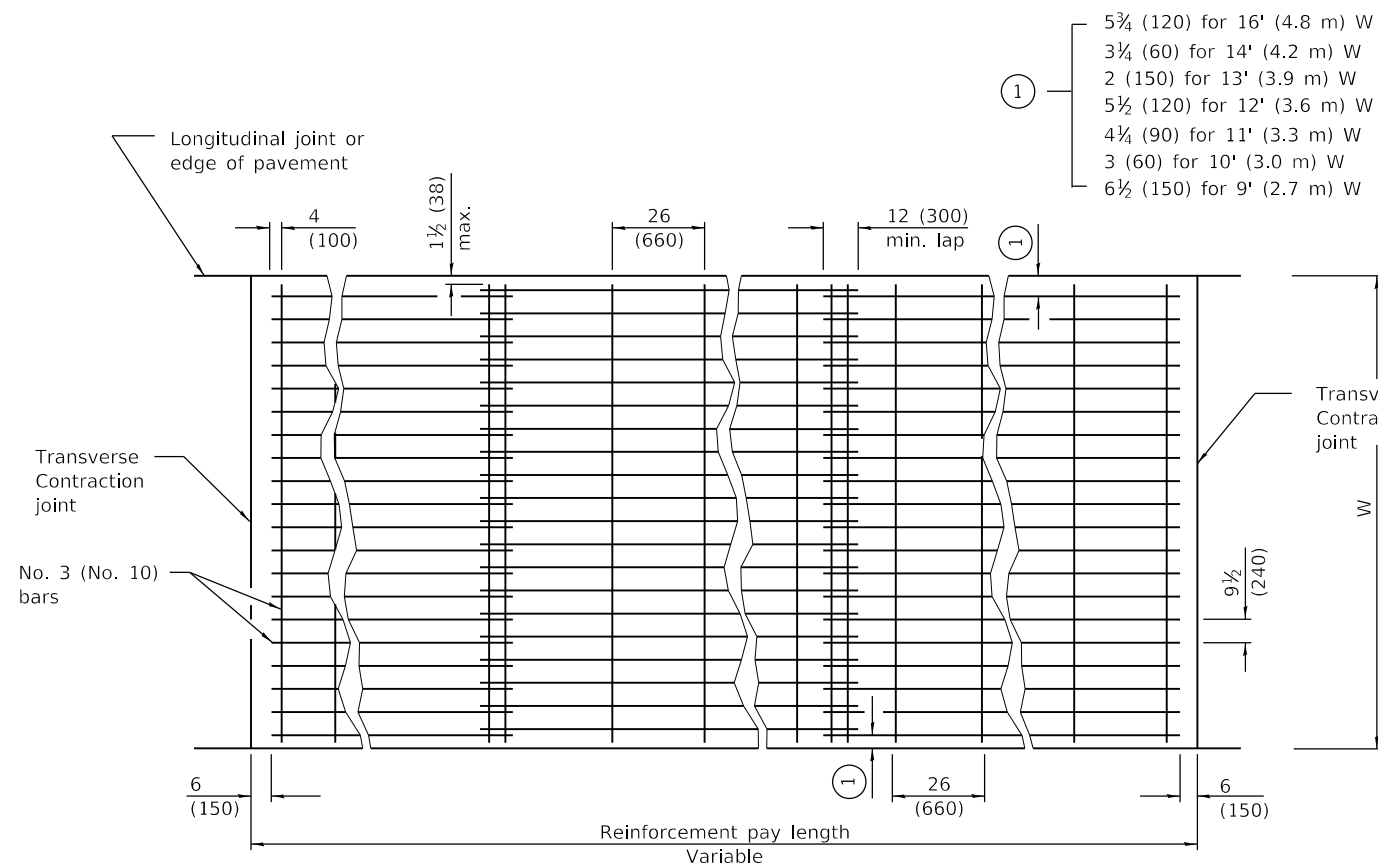

Approximately 63 lbs./100 sq. ft. (3.07 kg/m²)

Approximately 63 lbs./100 sq. ft. (3.07 kg/m²)

When clipped bar mats are used, each bar intersection shall be clipped with W1.7 (3.74) wire.

TYPE B

TYPE A

* When the 12 (300) minimum cannot be achieved, the transverse joints shall be extended to either the longitudinal joint or edge of pavement.

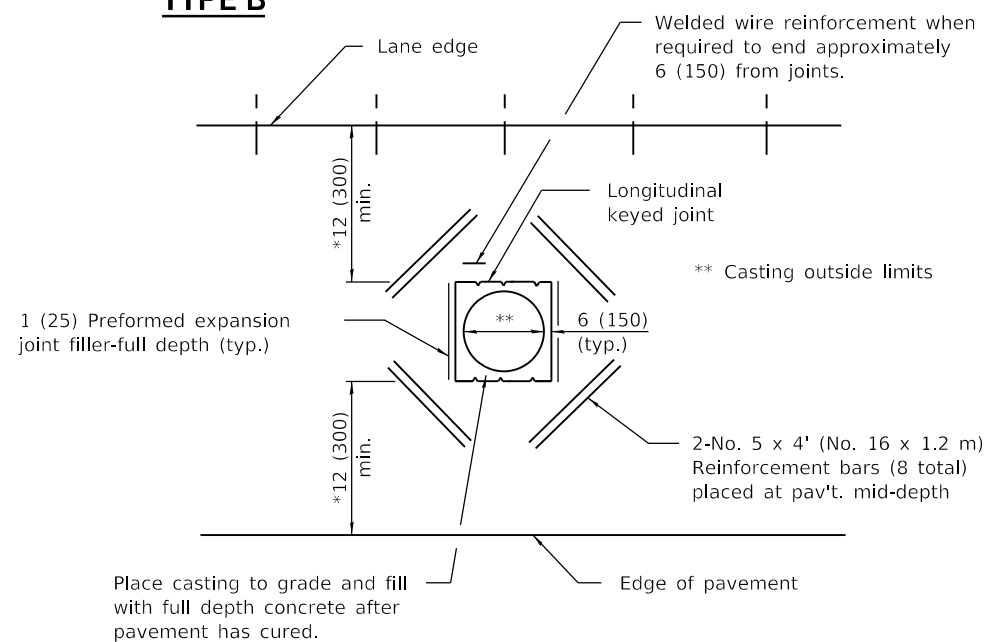

DETAIL OF ADDED REINFORCEMENT FOR PAVEMENT BLOCKS-OUTS

GENERAL NOTES

Pavement block-outs shall be at least 24 (600) from contraction joints.

Welded wire reinforcement which is lapped longitudinally shall have a minimum lap of 6 (150).

Welded wire reinforcement may be positioned with the transverse wires on top or bottom of the longitudinal wires.

All dimensions are in inches (millimeters) unless otherwise shown.

DATE	REVISIONS
4-1-16	Changed terminology to 'welded wire reinforcement'.
	Renamed standard.
1-1-08	Switched units to English (metric).

PAVEMENT WELDED WIRE REINFORCEMENT

STANDARD 420701-03

Illinois Department of Transportation

PASSED April 1, 2016

Michael Beard
ENGINEER OF POLICY AND PROCEDURES

APPROVED April 1, 2016

[Signature]
ENGINEER OF DESIGN AND ENVIRONMENT

ISSUED 1-1-97

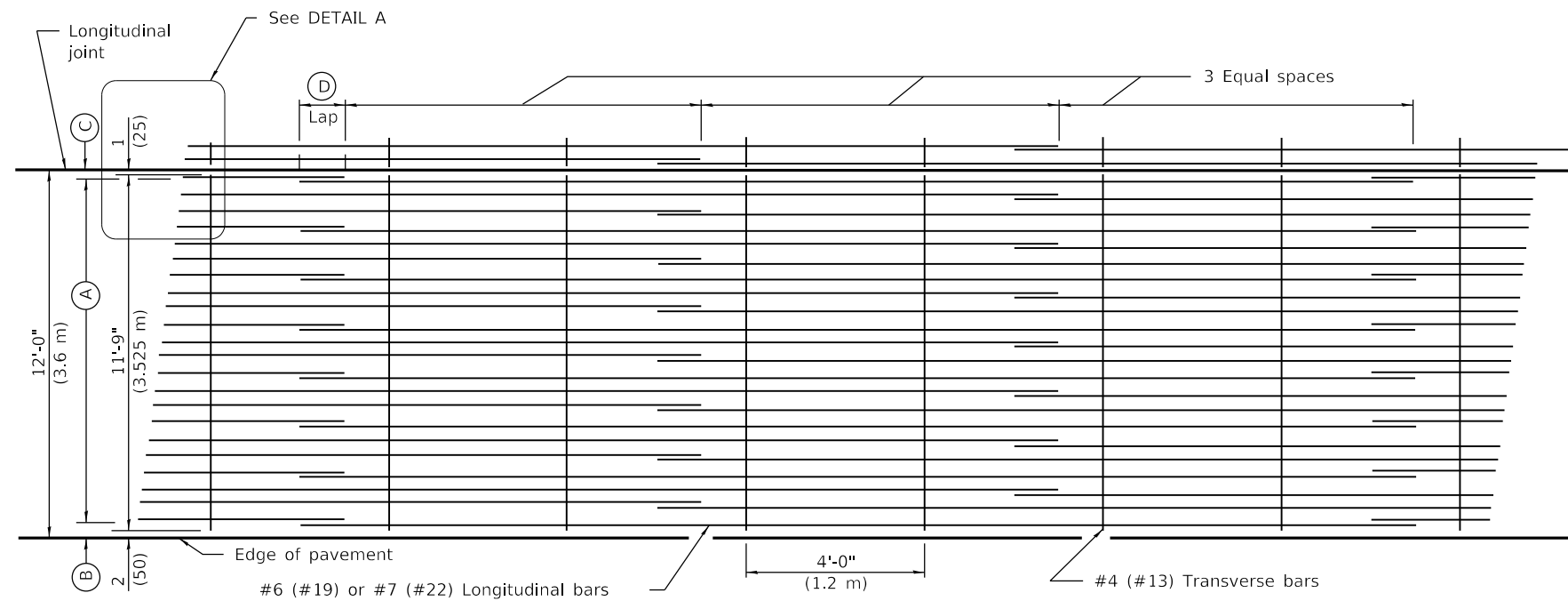

LAP DETAIL I

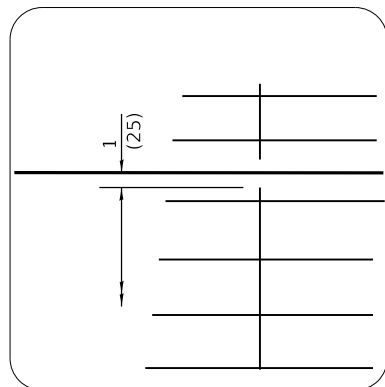

DETAIL A

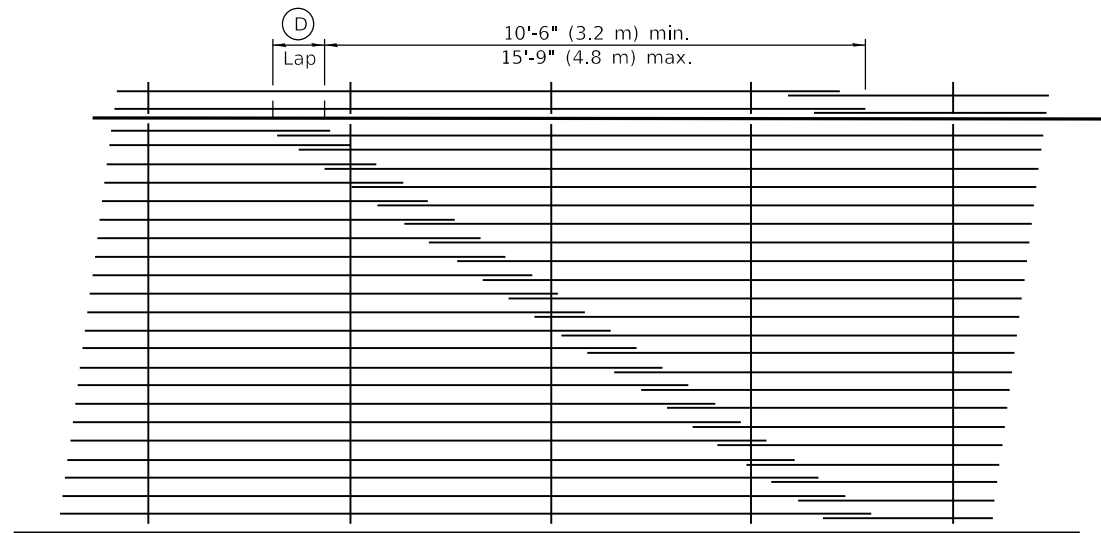

LAP DETAIL II

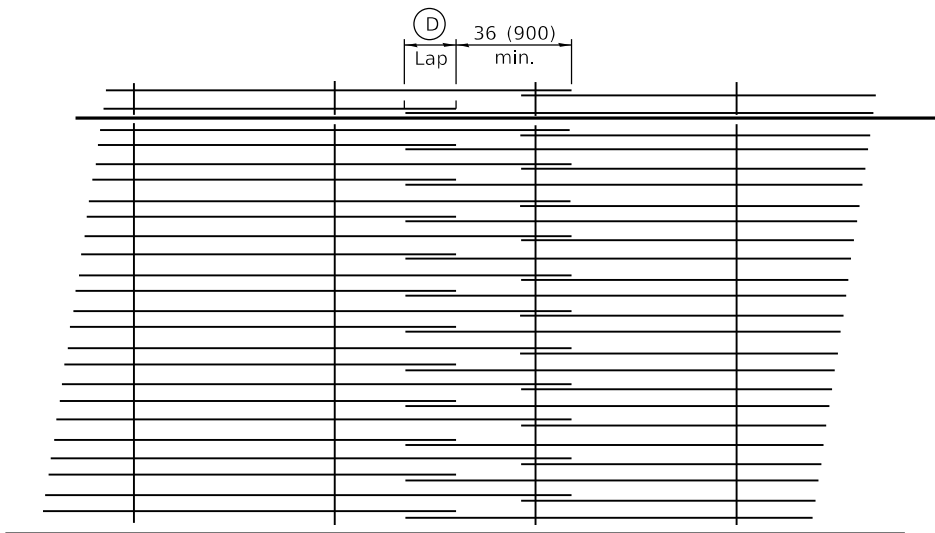

LAP DETAIL III

ENGLISH (inches)					
Bar Size	Pavement Thickness	(A) (Approx. Spacing)	(B)	(C)	(D)
#6	7¼ thru 8½	18 spaces (19 bars) @ 7½	3½	3	22
#6	8¼ thru 9½	20 spaces (21 bars) @ 6¾	3½	3	22
#6	9¼ thru 10½	22 spaces (23 bars) @ 6¼	3½	3	22
#6	10¼ thru 11½	24 spaces (25 bars) @ 5¾	3½	3	22
#6	11¼ thru 12½	27 spaces (28 bars) @ 5½	3½	3	22
#7	9¼ thru 10½	16 spaces (17 bars) @ 8¾	3½	3	26
#7	10¼ thru 11½	18 spaces (19 bars) @ 7¾	3½	3	26
#7	11¼ thru 12½	19 spaces (20 bars) @ 7¼	3½	3	26
#7	12¼ thru 13½	21 spaces (22 bars) @ 6½	3½	3	26
#7	13¼ thru 14½	23 spaces (24 bars) @ 6	3½	3	26
#7	14¼ thru 15½	24 spaces (25 bars) @ 5¾	3½	3	26
#7	15¼ thru 16½	26 spaces (27 bars) @ 5¼	3½	3	26

METRIC (mm)					
Bar Size	Pavement Thickness	(A) (Approx. Spacing)	(B)	(C)	(D)
#19	200 thru 220	18 spaces (19 bars) @ 191	90	75	560
#19	230 thru 250	21 spaces (22 bars) @ 163	95	80	560
#19	260 thru 280	23 spaces (24 bars) @ 149	90	80	560
#19	290 thru 310	26 spaces (27 bars) @ 132	90	75	560
#19	320 thru 340	29 spaces (30 bars) @ 118	95	80	560
#22	230 thru 250	15 spaces (16 bars) @ 229	90	75	660
#22	260 thru 280	17 spaces (18 bars) @ 202	90	75	660
#22	290 thru 310	19 spaces (20 bars) @ 181	90	70	660
#22	320 thru 340	21 spaces (22 bars) @ 163	95	80	660
#22	350 thru 370	23 spaces (24 bars) @ 149	90	80	660
#22	380 thru 400	25 spaces (26 bars) @ 137	95	80	660
#22	410 thru 430	27 spaces (28 bars) @ 127	90	80	660

GENERAL NOTES

Except as noted or shown, the dimensions and notes specified for LAP DETAIL I are typical for LAP DETAIL II and III.

The (B) dimension and the distance from the end of the transverse bar to the edge of pavement may be increased by 1 (25) for slip form paving.

The minimum length of longitudinal bars shall be 30' (9 m) except as required to establish the lap arrangement selected.

All dimensions are in inches (millimeters) unless otherwise shown.

DATE	REVISIONS
4-1-16	Revised general notes with respect to 30' bar length.
1-1-08	Switched units to English (metric).

BAR REINFORCEMENT FOR CRC PAVEMENT

STANDARD 421001-03

Illinois Department of Transportation

PASSED April 1, 2016
Michael Beard
 ENGINEER OF POLICY AND PROCEDURES

APPROVED April 1, 2016
[Signature]
 ENGINEER OF DESIGN AND ENVIRONMENT

ISSUED 1-1-97

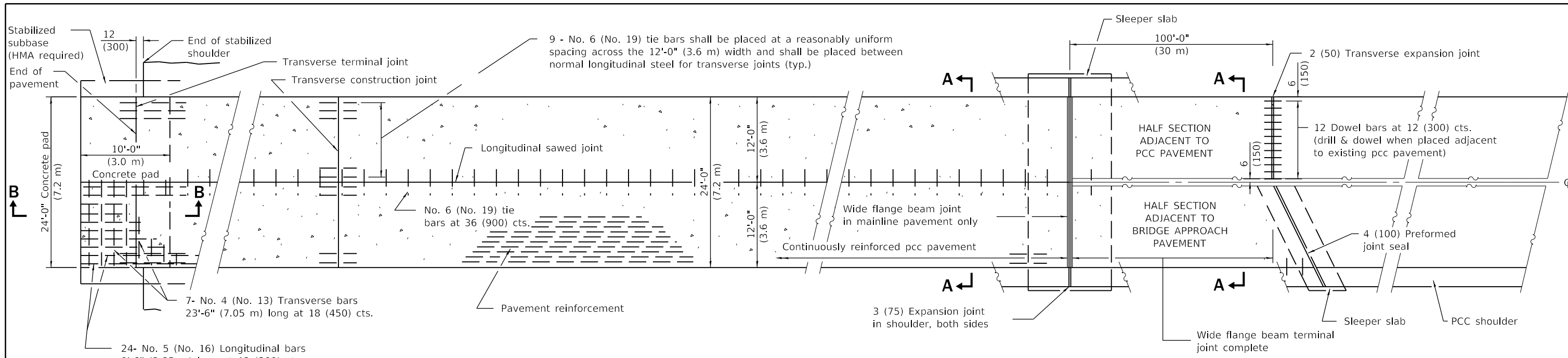

PLAN

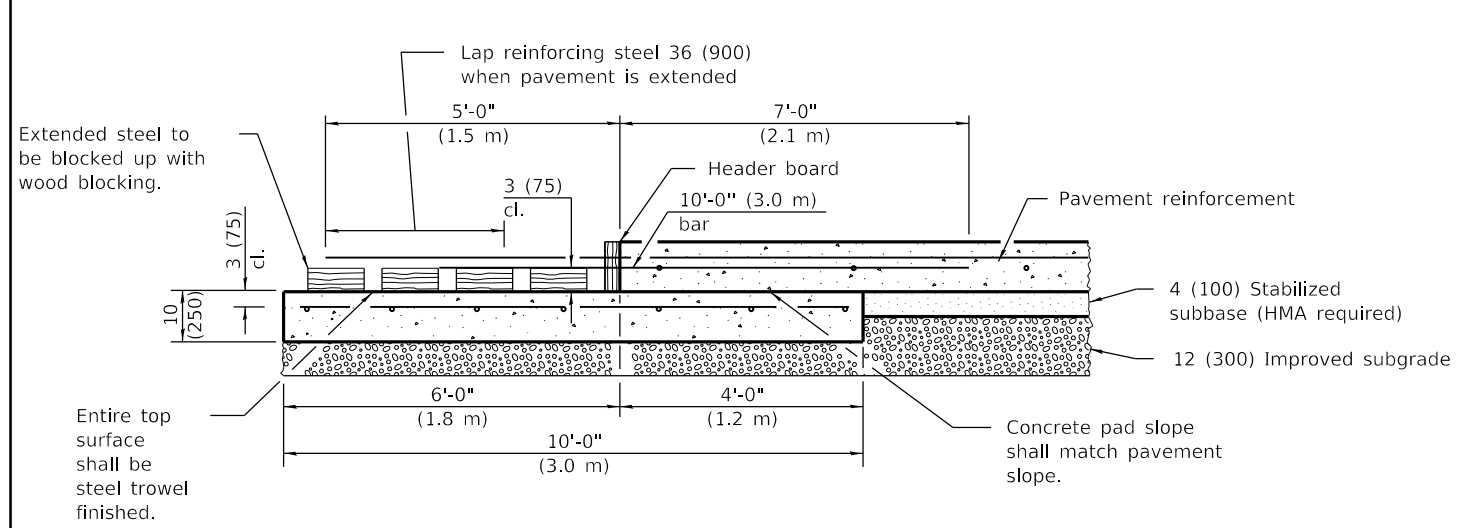

TRANSVERSE TERMINAL JOINT SECTION B-B

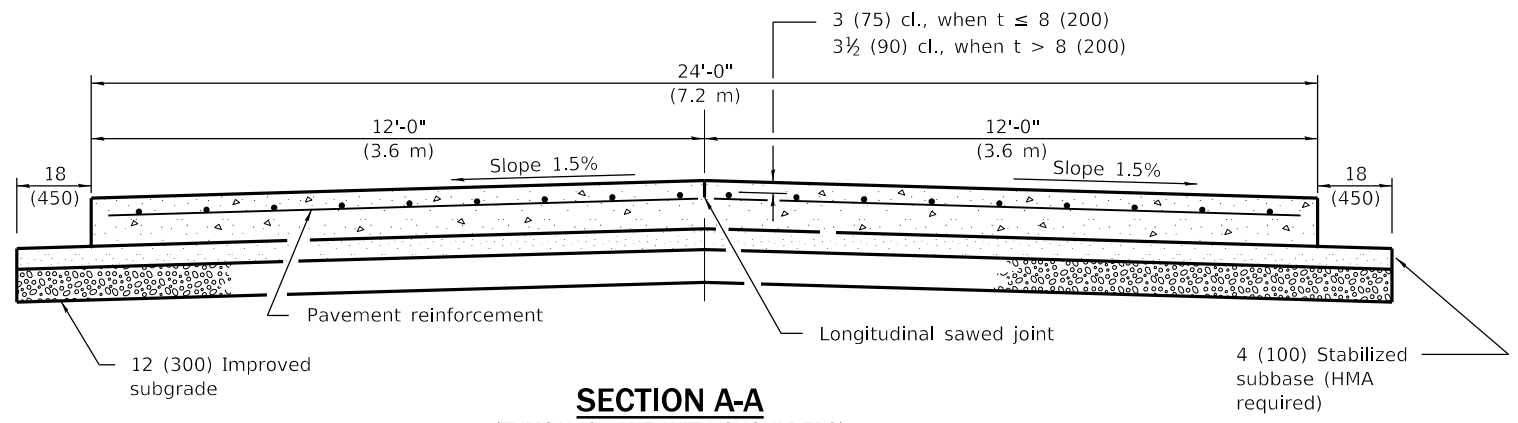

SECTION A-A (TYPICAL 2-LANE WITH SHOULDERS)

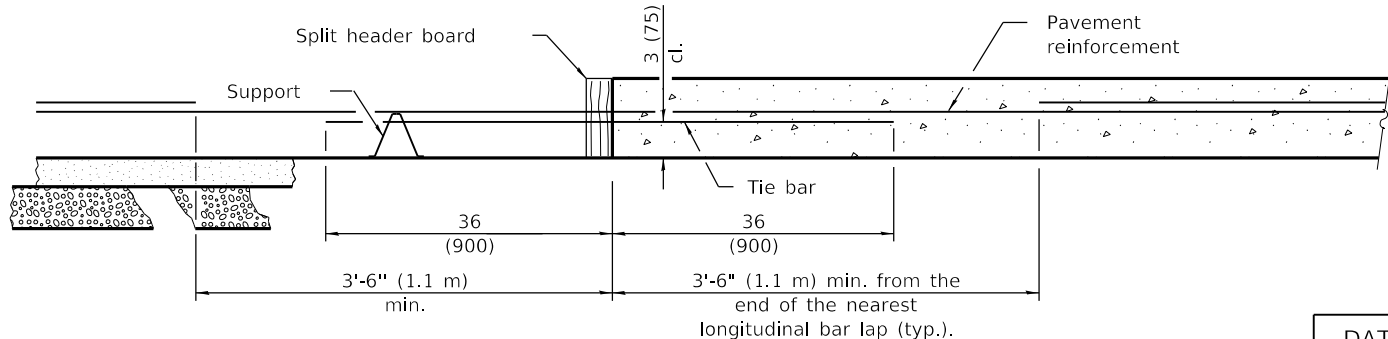

TRANSVERSE CONSTRUCTION JOINT

GENERAL NOTES

Sealant components for the wide flange beam terminal joint shall be as follows: The sealant shall be Dow Corning 888 Silicone Highway Joint Sealant. The tape shall be Polyethylene Tape No. 40. The primer, used on the metal only, shall be Dow Corning 1200. At the Contractor's option the joint may be sealed as shown in the optional groove detail.

See Standards 420001 and 420401 for joint details not shown.

See Standard 421001 for details of pavement reinforcement.

All dimensions are in inches (millimeters) unless otherwise shown.

Illinois Department of Transportation

PASSED January 1, 2018
Michael Beard
 ENGINEER OF POLICY AND PROCEDURES

APPROVED January 1, 2018
Marcus M. Beck
 ENGINEER OF DESIGN AND ENVIRONMENT

ISSUED 1-1-97

DATE	REVISIONS
1-1-18	Changed tie bar spacing to 36 (900) cts.
1-1-14	Added exp. jnts. in shlds. & omitted bars, cnst. jnt. over wide flange beam slpr slab.

24' (7.2 m)
CRC PAVEMENT
 (WITH WIDE FLANGE BEAM TERMINAL JOINT)
 (Sheet 1 of 2)

STANDARD 421101-10

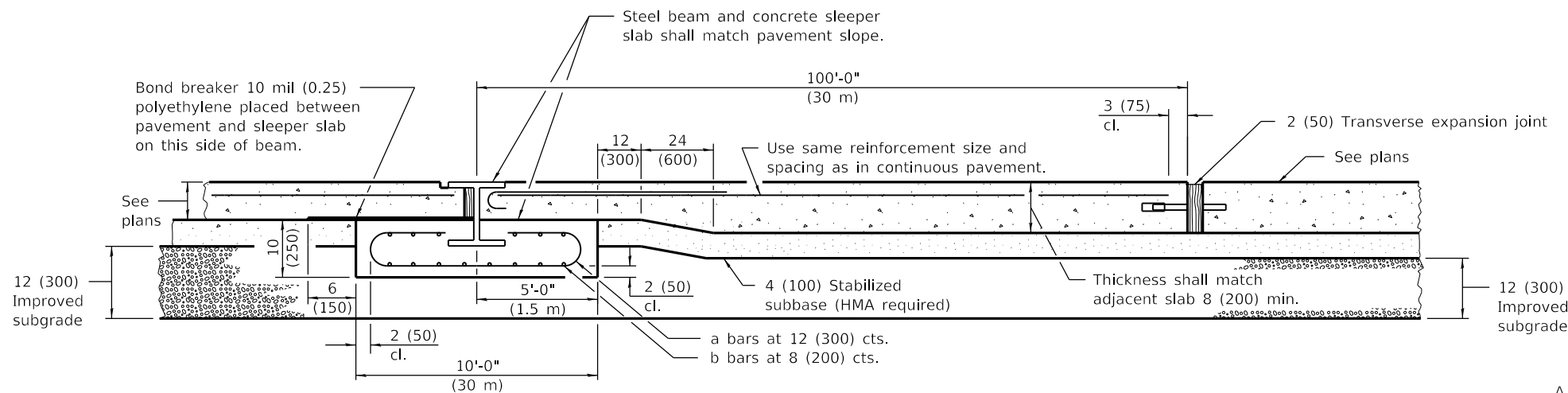

WIDE FLANGE BEAM TERMINAL JOINT

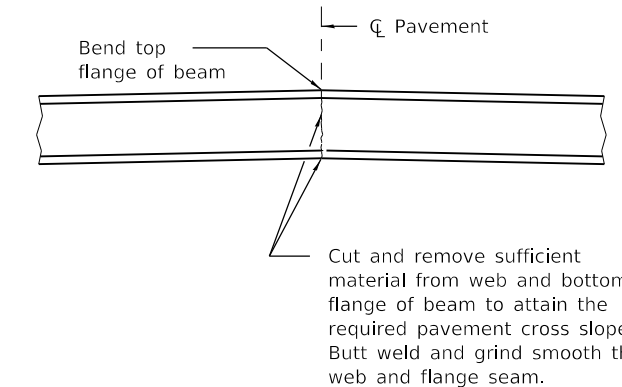

DETAIL OF CUTTING AND WELDING BEAM

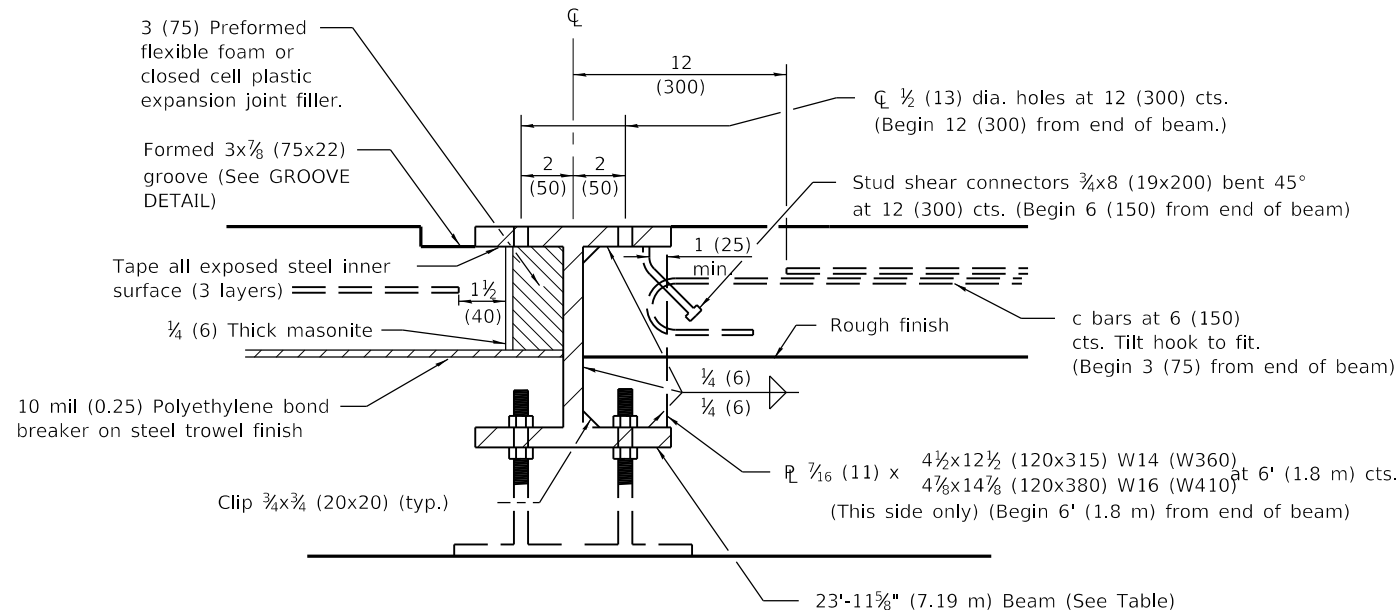

DETAIL AT BEAM

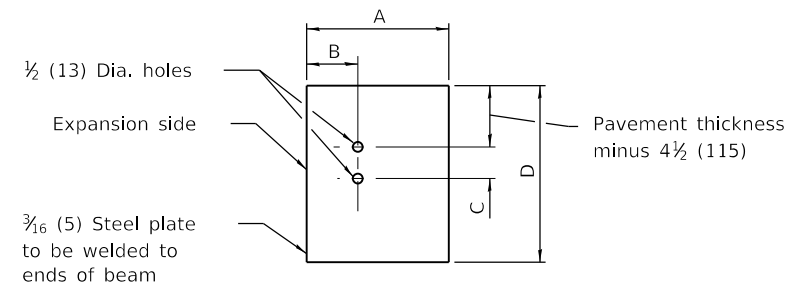

END PLATE

PAVEMENT THICKNESS	<10 (250)	≥10 (250)
BEAM SIZE	W14x82 (W360x122)	W16x100 (W410x1149)
A	10 5/8 (255)	10 5/8 (265)
B	4 5/16 (110)	4 7/16 (115)
C	3 (75)	4 (100)
D	14 1/4 (360)	17 (430)

MATERIALS REQUIRED FOR ONE TRANSVERSE TERMINAL JOINT COMPLETE	
Concrete, cu. yds. (m³)	7.4 (5.4)
Reinforcement bars, lbs. (kg)	348 (160)
Pavement reinforcement, sq. yds. (m²)	13.3 (10.8)

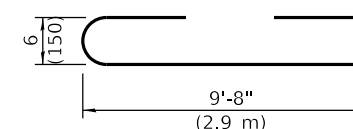

BAR a

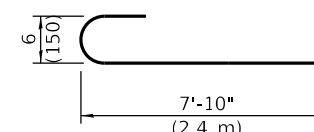

BAR c

MATERIALS REQUIRED FOR ONE WIDE FLANGE BEAM TERMINAL JOINT COMPLETE				
Bar	No.	Size	Length	Shape
a	24	No. 4 (No. 13)	19'-0" (5.8 m)	
b	29	No. 5 (No. 16)	23'-8" (7.1 m)	
c	48	No. 6 (No. 19)	8'-6" (2.6 m)	
Concrete, cu. yds. (m³)		7.4 (5.4)		
Reinforcement Bars, lbs. (kg)		1635 (740)		
Structural Steel, lbs. (kg)		W14 (W360) 2025* (906*) W16 (W410) 2466* (1104*)		
*Weight includes beam, end plates, stiffener plates and studs.				
Pavement, sq. yds. (m²)		266.7 (216)		
Pavement Reinforcement, sq. yds. (m²)		266.7 (216)		
Stabilized Subbase, sq. yds. (m²)		285 (230.8)		
Improved Subgrade, sq. yds. (m²)		300 (243)		

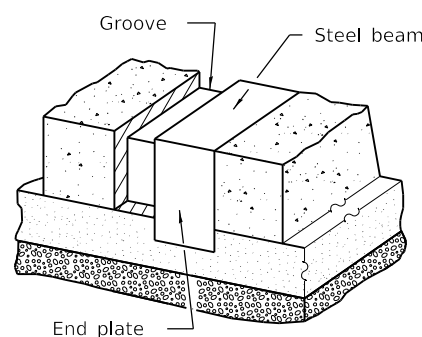

VIEW OF GROOVE AT EDGE OF PAVEMENT

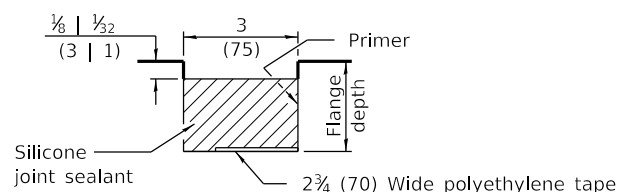

GROOVE DETAIL

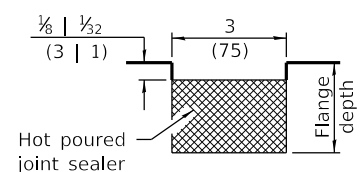

GROOVE DETAIL (OPTIONAL)

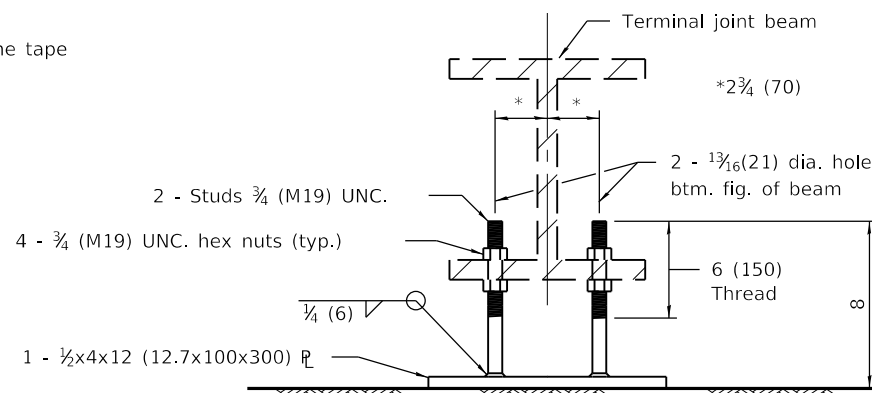

OPTIONAL ADJUSTABLE CHAIR

Illinois Department of Transportation

PASSED January 1, 2018
Michael Brand
ENGINEER OF POLICY AND PROCEDURES

APPROVED January 1, 2018
Maureen M. Beck
ENGINEER OF DESIGN AND ENVIRONMENT

ISSUED 1-1-97

24' (7.2 m)

CRC PAVEMENT

(WITH WIDE FLANGE BEAM TERMINAL JOINT)

(Sheet 2 of 2)

STANDARD 421101-10

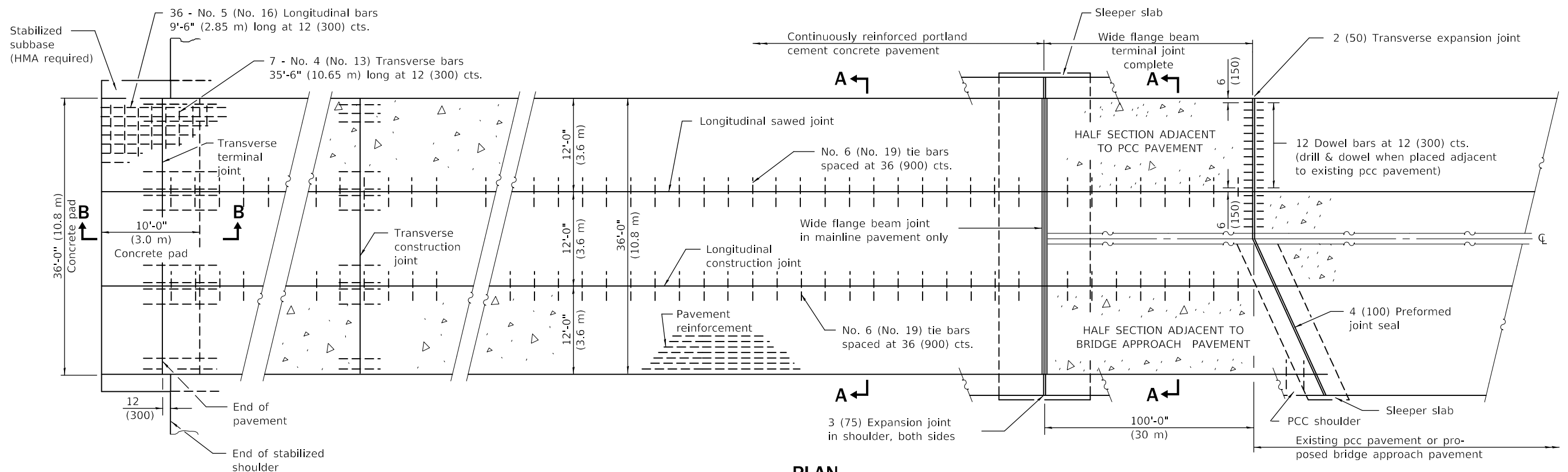

PLAN

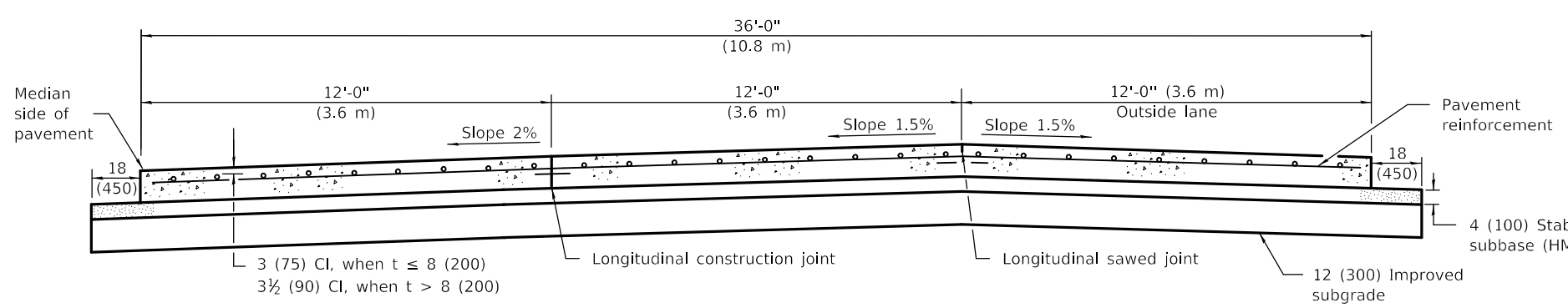

SECTION A-A
(TYPICAL 3-LANE, 1-WAY WITH SHOULDERS)

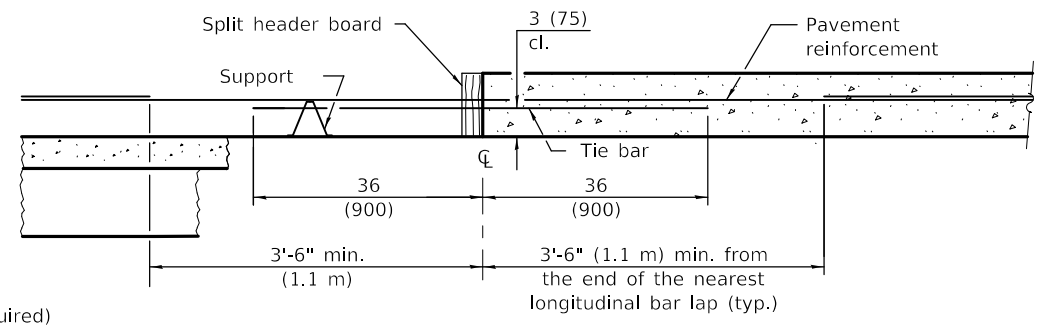

TRANSVERSE CONSTRUCTION JOINT

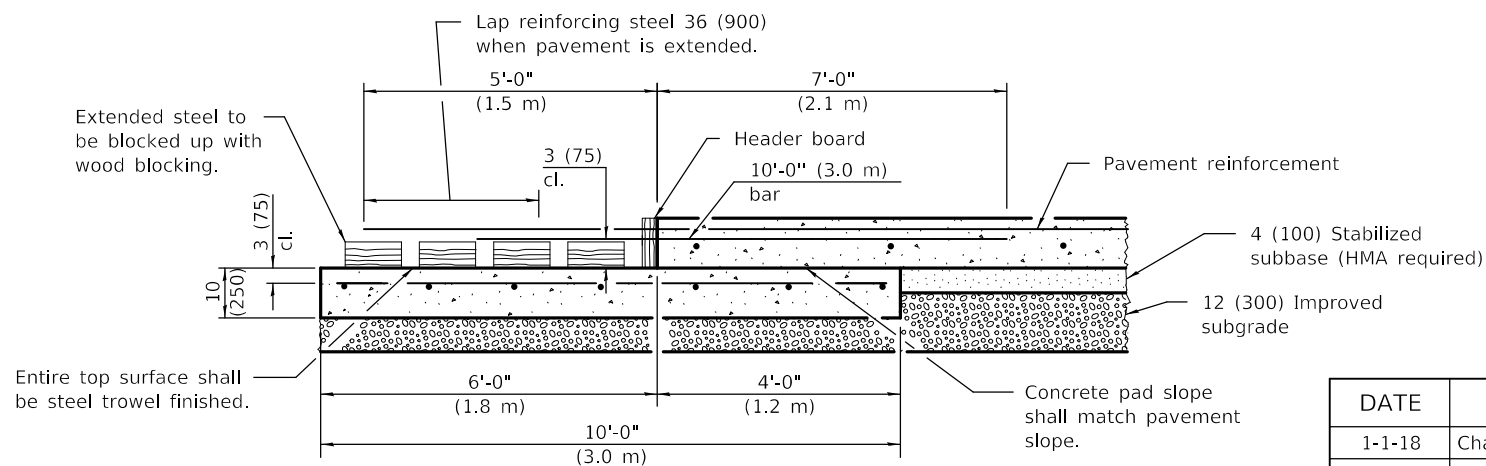

TRANSVERSE TERMINAL JOINT
SECTION B-B

GENERAL NOTES

Sealant components for the wide flange beam terminal joint shall be as follows: The sealant shall be Dow Corning 888 Silicone Highway Joint Sealant. The tape shall be Polyethylene Tape No. 40. The primer, used on the metal only, shall be Dow Corning 1200. At the Contractor's option the joint may be sealed as shown in the optional groove detail.

See Standard 421001 for details of pavement reinforcement.

See Standards 420001 and 420401 for joint details not shown.

All dimensions shall be in inches (millimeters) unless otherwise shown.

DATE	REVISIONS
1-1-18	Changed tie bar spacing to 36 (900) cts.
1-1-14	Added exp. jnts. in shlds. & omitted bars, cnst. jnt. over wide flange beam slpr. slab.

36' (10.8 m)
CRC PAVEMENT
(WITH WIDE FLANGE BEAM TERMINAL JOINT)
(Sheet 1 of 2)

STANDARD 421106-10

Illinois Department of Transportation

PASSED January 1, 2018
Michael Beard
ENGINEER OF POLICY AND PROCEDURES

APPROVED January 1, 2018
Maureen M. Beck
ENGINEER OF DESIGN AND ENVIRONMENT

ISSUED 1-1-97

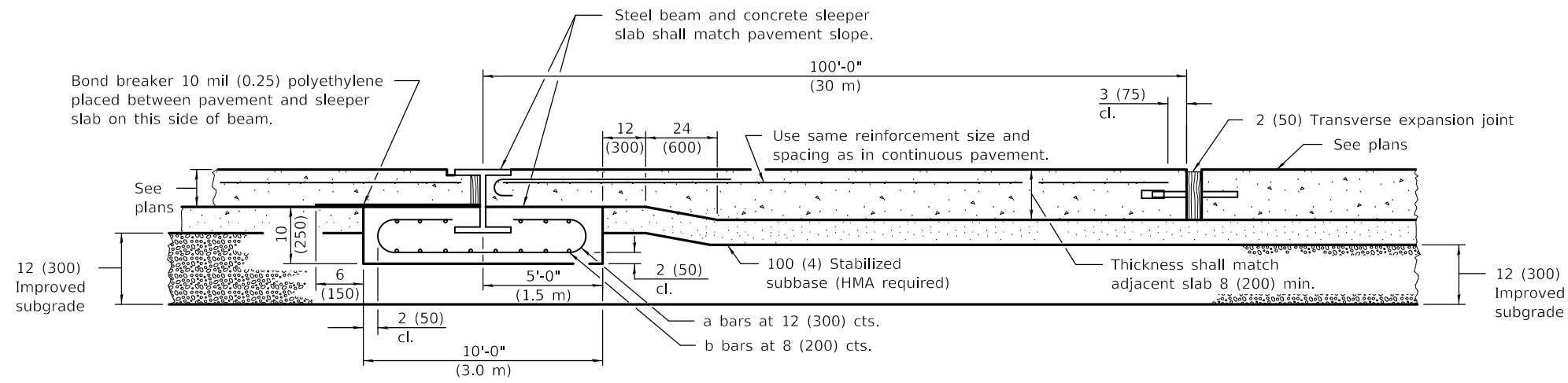

WIDE FLANGE BEAM TERMINAL JOINT

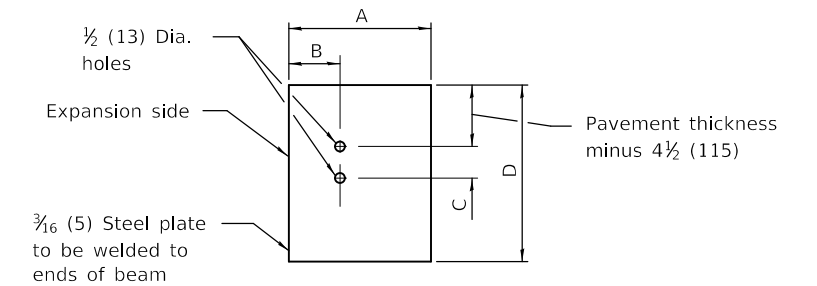

END PLATE

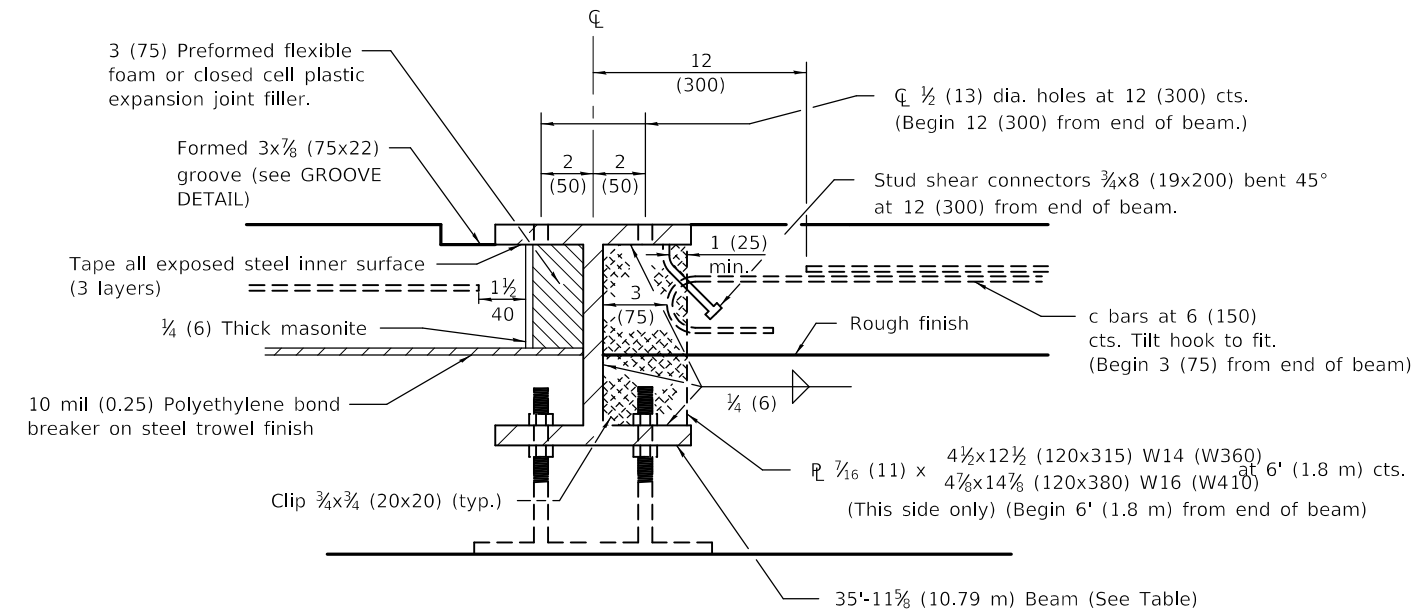

DETAIL AT BEAM

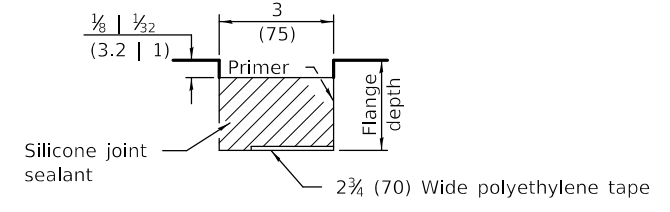

GROOVE DETAIL

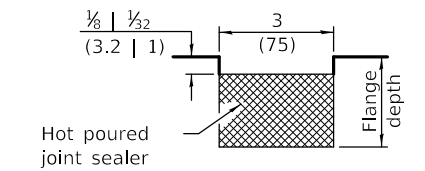

GROOVE DETAIL (OPTIONAL)

PAVEMENT THICKNESS	<10 (250)	≥10 (250)
BEAM SIZE	W14X82 (W360X122)	w16x100 (W410x149)
A	10 7/8 (255)	10 3/8 (265)
B	4 3/16 (110)	4 1/16 (115)
C	3 (75)	4 (100)
D	14 1/4 (360)	17 (430)

MATERIALS REQUIRED FOR ONE TRANSVERSE TERMINAL JOINT COMPLETE	
Concrete, cu. yds. (m³)	11.1 (8.1)
Reinforcement bars, lbs. (kg)	523 (235)
Pavement reinforcement, sq. yds. (m²)	20 (16.2)

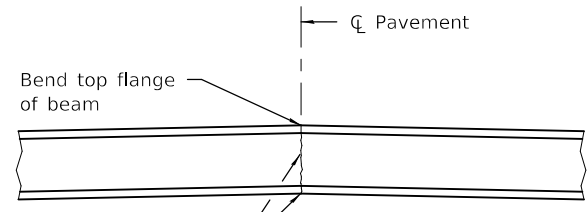

DETAIL OF CUTTING AND WELDING BEAM

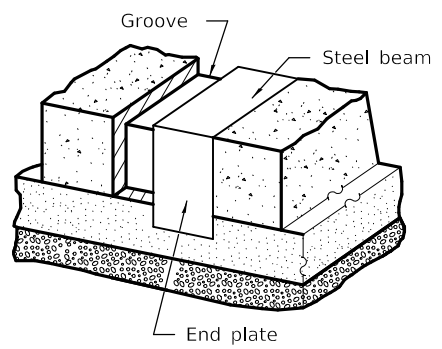
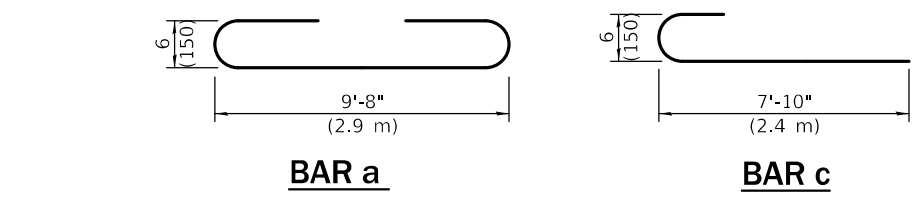

VIEW OF GROOVE AT EDGE OF PAVEMENT

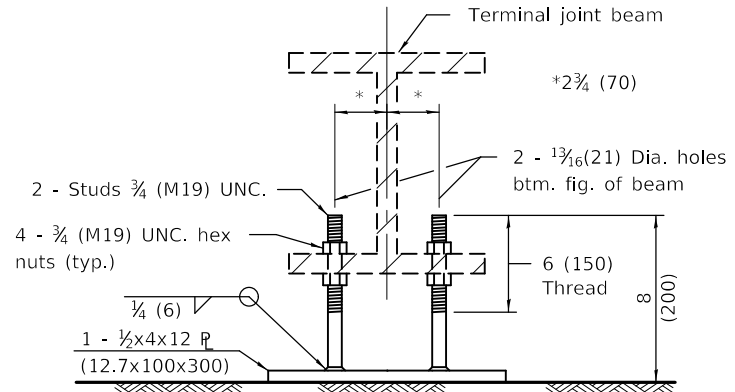

OPTIONAL ADJUSTABLE CHAIR

MATERIALS REQUIRED FOR ONE WIDE FLANGE BEAM TERMINAL JOINT COMPLETE				
Bar	No.	Size	Length	Shape
a	36	No. 4 (No. 13)	19'-0" (5.8 m)	
b	29	No. 5 (No. 16)	35'-8" (10.7 m)	
c	72	No. 6 (No. 19)	8'-6" (2.6 m)	
Concrete, cu. yds. (m³)				11.1 (8.1)
Reinforcement Bars, lbs. (kg)				2455 (1115)
Structural Steel, lbs. (kg)	W14 (W360) 3040 (1360)			
	W16 (W410) 3710 (1655)			
* Weight includes beam, end plates, stiffener plates and studs.				
Pavement, sq. yds. (m²)				400 (324)
Pavement Reinforcement, sq. yds. (m²)				400 (324)
4 (100) Stabilized Subbase, sq. yds. (m²)				411.6 (333.5)
Improved Subgrade, sq. yds. (m²)				433.3 (351)

36' (10.8 m) CRC PAVEMENT
(WITH WIDE FLANGE BEAM TERMINAL JOINT)
(Sheet 2 of 2)

STANDARD 421106-10

Illinois Department of Transportation

PASSED January 1, 2018
Michael Brand
ENGINEER OF POLICY AND PROCEDURES

APPROVED January 1, 2018
Maureen M. Adams
ENGINEER OF DESIGN AND ENVIRONMENT

ISSUED 1-1-97

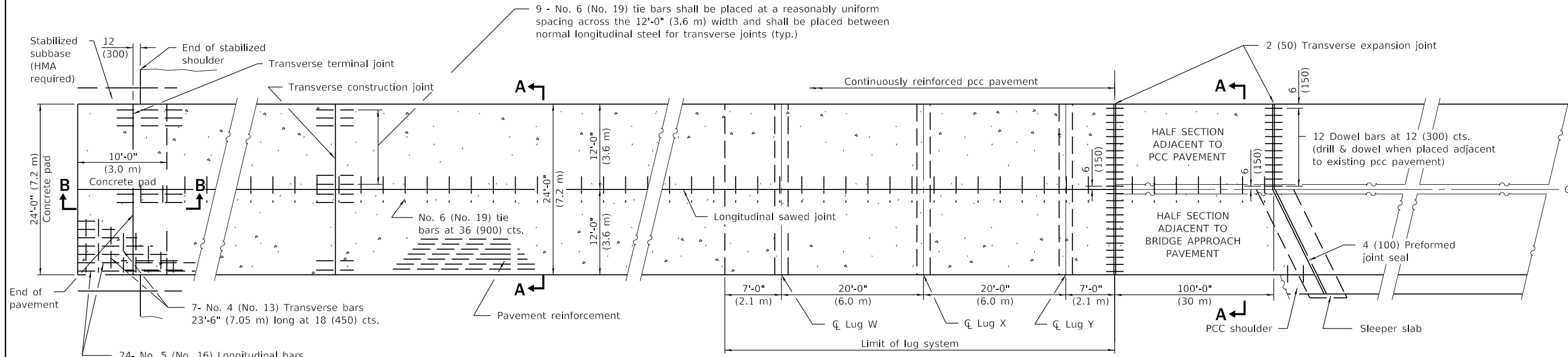

PLAN

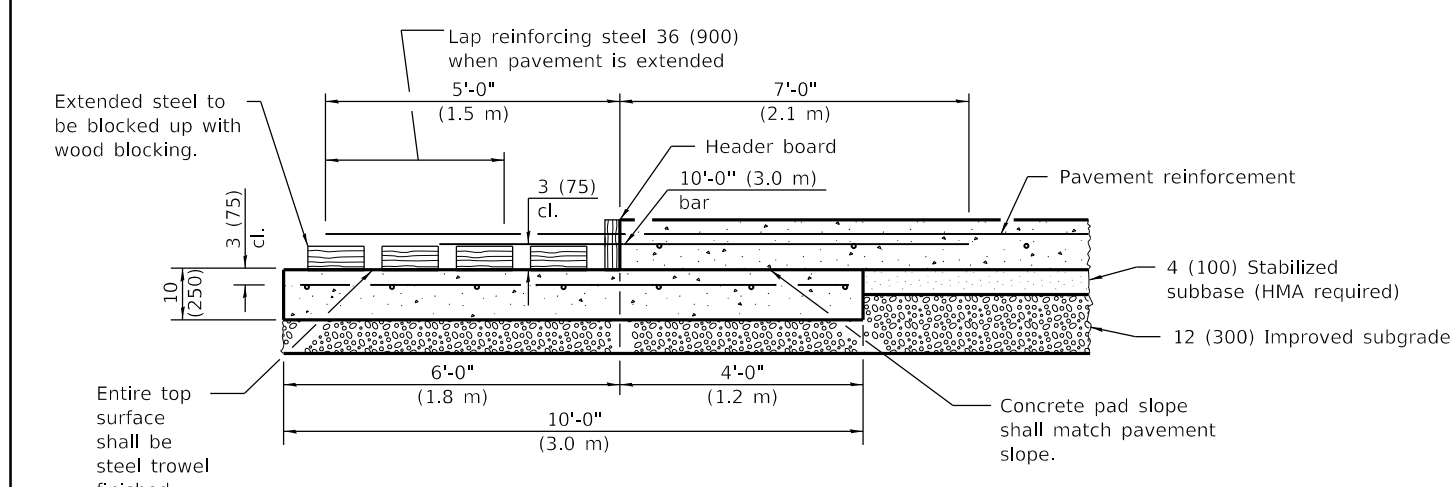

TRANSVERSE TERMINAL JOINT SECTION B-B

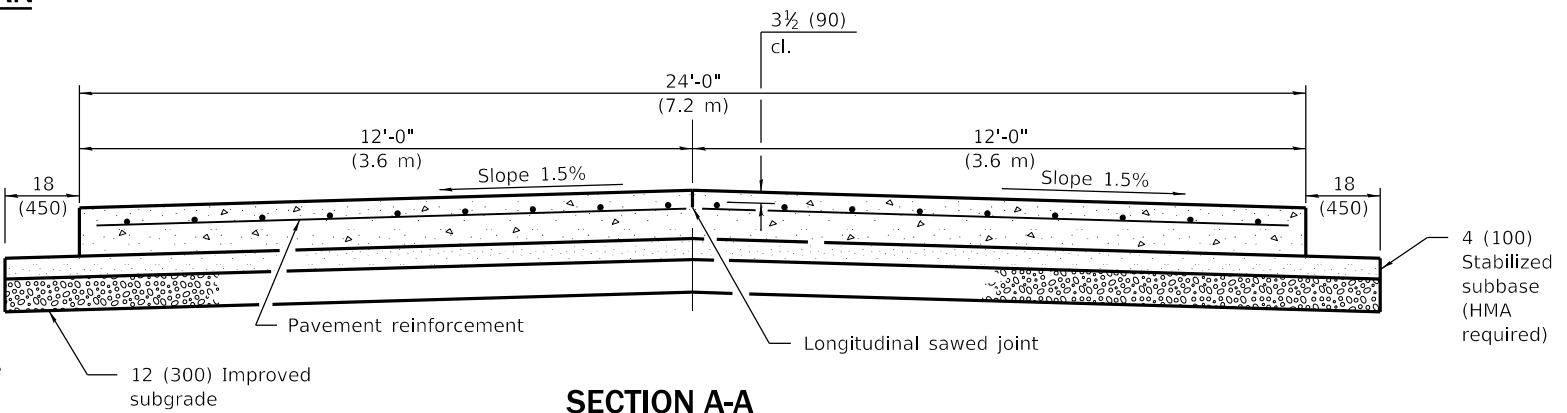

SECTION A-A
(TYPICAL 2-LANE WITH SHOULDERS)

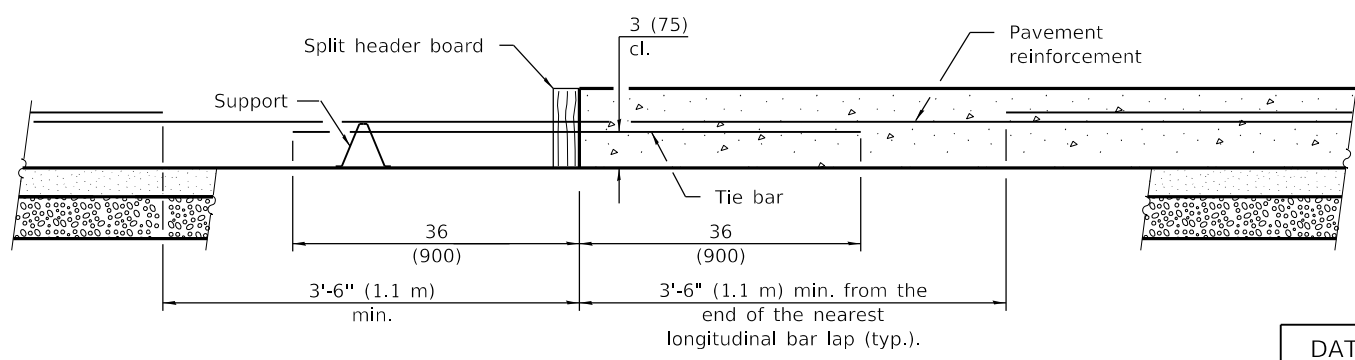

TRANSVERSE CONSTRUCTION JOINT

GENERAL NOTES

See Standard 421001 for details of pavement reinforcement.

See Standards 420001 and 420401 for joint details not shown.

All dimensions are in inches (millimeters) unless otherwise shown.

DATE	REVISIONS
1-1-18	Changed tie bar spacing to 36 (900) cts.
1-1-08	Switched units to English (metric). Revised Lug. Sys. Table.

24' (7.2 m)
CRC PAVEMENT
(WITH LUG SYSTEM)
(Sheet 1 of 2)

STANDARD 421201-07

Illinois Department of Transportation

PASSED January 1, 2018
Michael Beard
ENGINEER OF POLICY AND PROCEDURES

APPROVED January 1, 2018
Marcus M. Beck
ENGINEER OF DESIGN AND ENVIRONMENT

ISSUED 1-1-97

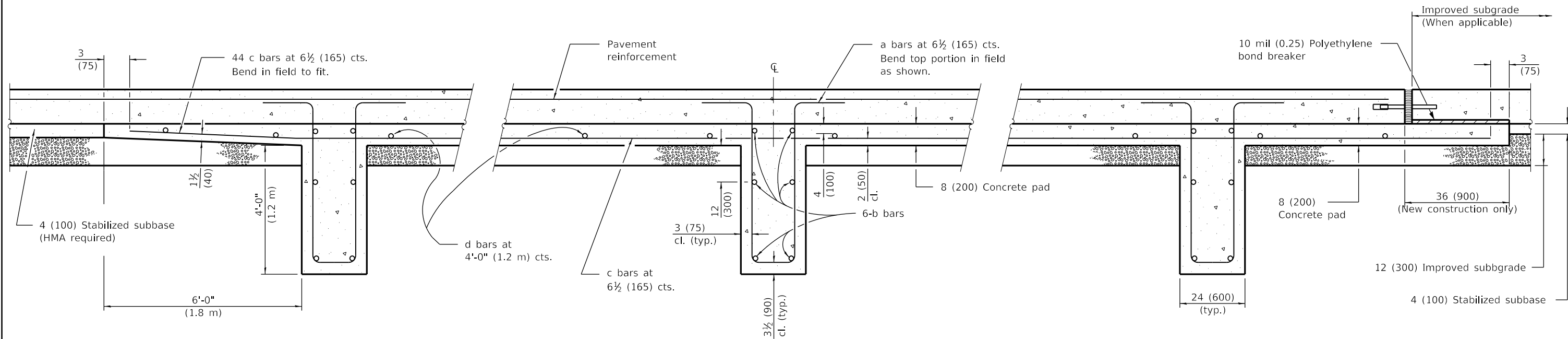

SECTION AT LUG W

SECTION AT LUG X

SECTION AT LUG Y

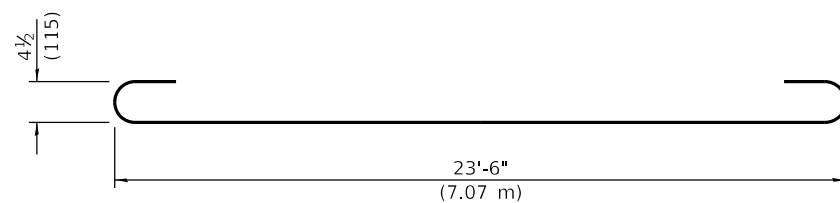
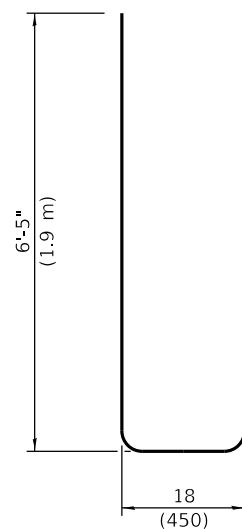

MATERIALS REQUIRED FOR (1) ONE LUG SYSTEM
(Excluding Pavement Concrete and Pavement Reinforcement)

Bar	Qty.	Size	Length	Shape
a	132	No. 8 (No. 25)	14'-0" (4.25 m)	
b	18	No. 5 (No. 16)	24'-9" (7.43 m)	
c	132	No. 5 (No. 16)	20'-0" (6.10 m)	
d	28	No. 4 (No. 13)	11'-9" (3.52 m)	

Concrete, cu. yds. (m ³)	64.0 (48.9)
Reinforcing Bars, lbs. (kg)	8372 (3800)
Concrete Pad, sq. yds. (m ²)	144 (120)
Improved Subgrade, sq. yds. (m ²)	162 (135)

Illinois Department of Transportation

PASSED January 1, 2018
Michael Beard
 ENGINEER OF POLICY AND PROCEDURES

APPROVED January 1, 2018
Maureen M. Beck
 ENGINEER OF DESIGN AND ENVIRONMENT

ISSUED 1-1-97

24' (7.2 m)
CRC PAVEMENT
 (WITH LUG SYSTEM) (Sheet 2 of 2)

STANDARD 421201-07

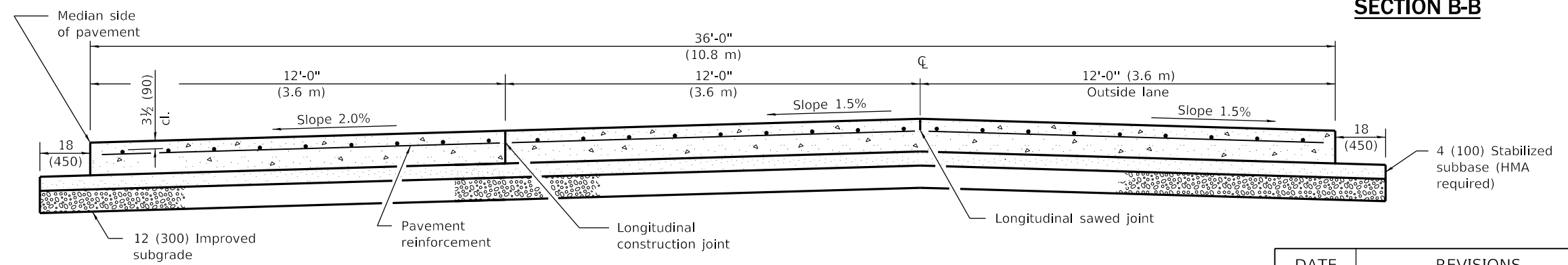
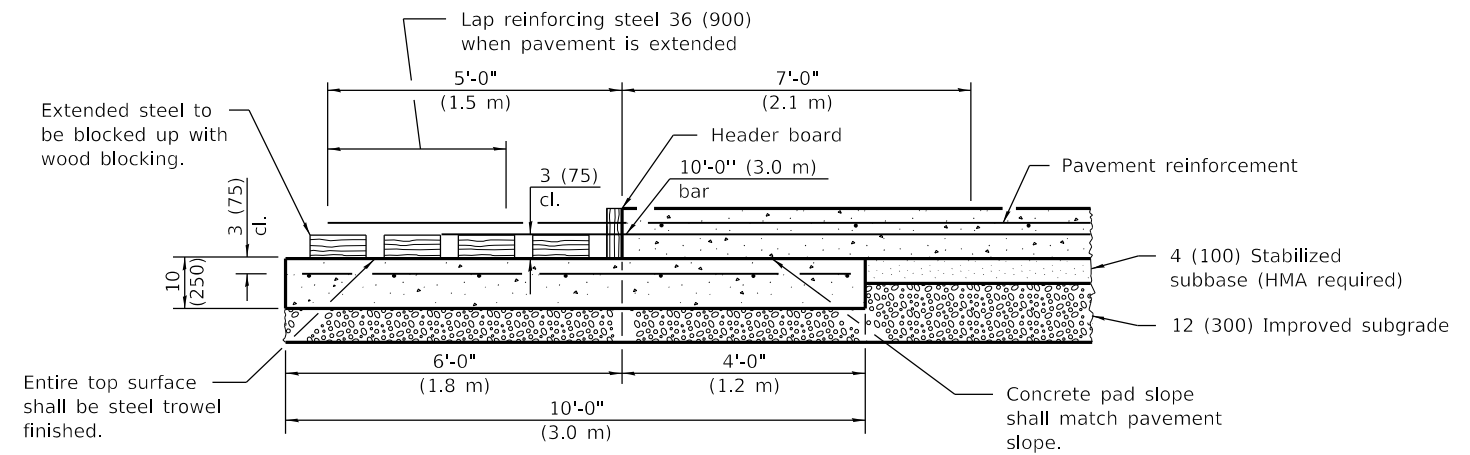
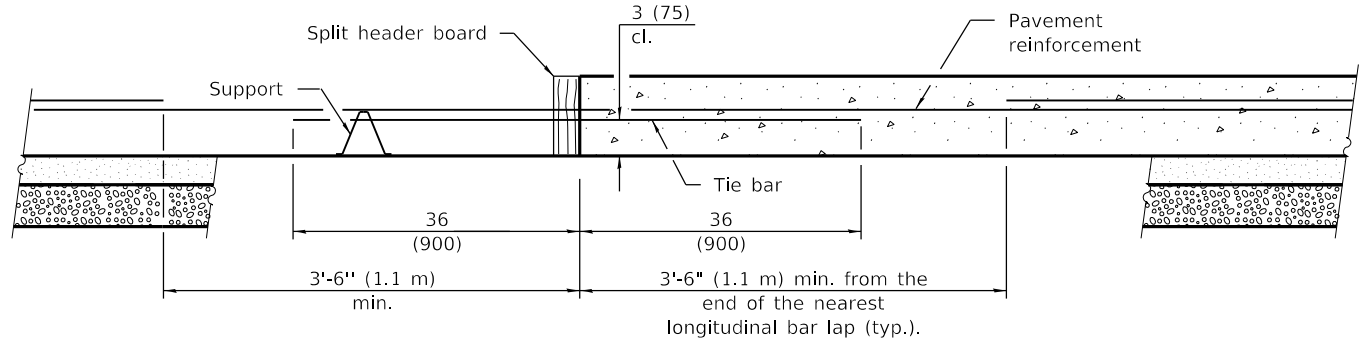
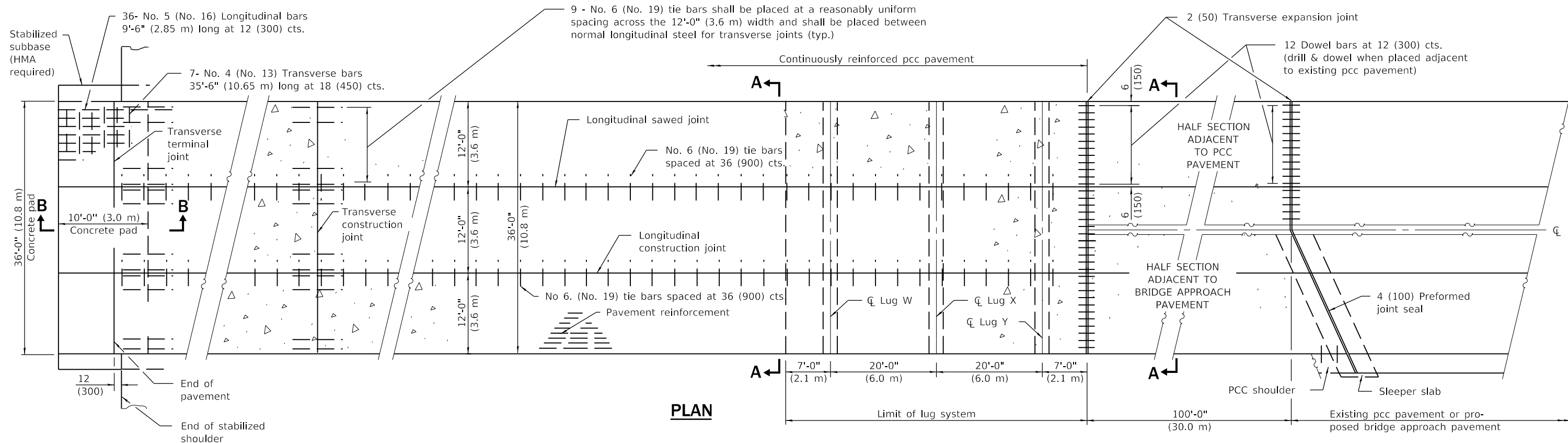

GENERAL NOTES

See Standard 421001 for details of pavement reinforcement.

See Standards 420001 and 420401 for joint details not shown.

All dimensions are in inches (millimeters) unless otherwise shown.

DATE	REVISIONS
1-1-18	Changed tie bar spacing to 36 (900).
1-1-08	Switched units to English (metric). Revised Lug Sys. Table.

36' (10.8 m)
CRC PAVEMENT
(WITH LUG SYSTEM)

(Sheet 1 of 2)

STANDARD 421206-07

Illinois Department of Transportation

PASSED January 1, 2018
Michael Beard
ENGINEER OF POLICY AND PROCEDURES

APPROVED January 1, 2018
Marcus M. Adams
ENGINEER OF DESIGN AND ENVIRONMENT

ISSUED 1-1-97

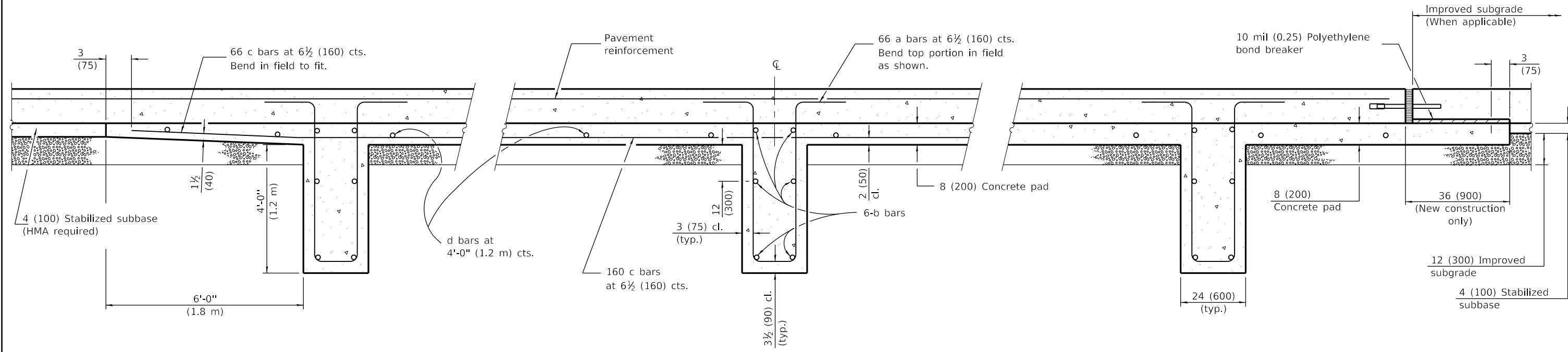

SECTION AT LUG W

SECTION AT LUG X

SECTION AT LUG Y

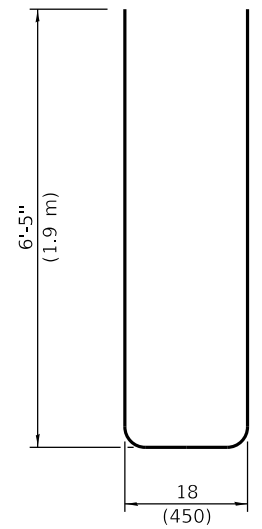

BAR a

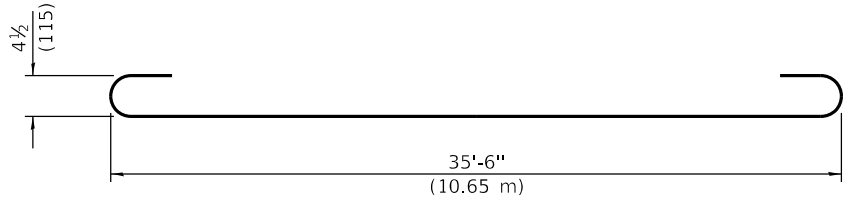

BAR b

MATERIALS REQUIRED FOR (1) ONE LUG SYSTEM (Excluding Pavement Concrete and Pavement Reinforcement)				
Bar	No.	Size	Length	Shape
a	198	No. 8 (No. 25)	14'-0" (4.25 m)	
b	18	No. 5 (No. 16)	36'-9" (11.30 m)	
c	198	No. 5 (No. 16)	20'-0" (6.10 m)	
d	42	No. 4 (No. 13)	11'-9" (3.52 m)	
Concrete, cu. yds. (m³)			96.0 (73.4)	
Reinforcing Bars, lbs. (kg)			12,550 (5695)	
Concrete Pad, sq. yds. (m²)			216 (181)	
Improved Subgrade, sq. yds. (m²)			208 (174)	

Illinois Department of Transportation

PASSED January 1, 2018
Michael Beard
 ENGINEER OF POLICY AND PROCEDURES

APPROVED January 1, 2018
Maureen M. Adams
 ENGINEER OF DESIGN AND ENVIRONMENT

ISSUED 1-1-97

36' (10.8 m)
CRC PAVEMENT
 (WITH LUG SYSTEM) (Sheet 2 of 2)

STANDARD 421206-07

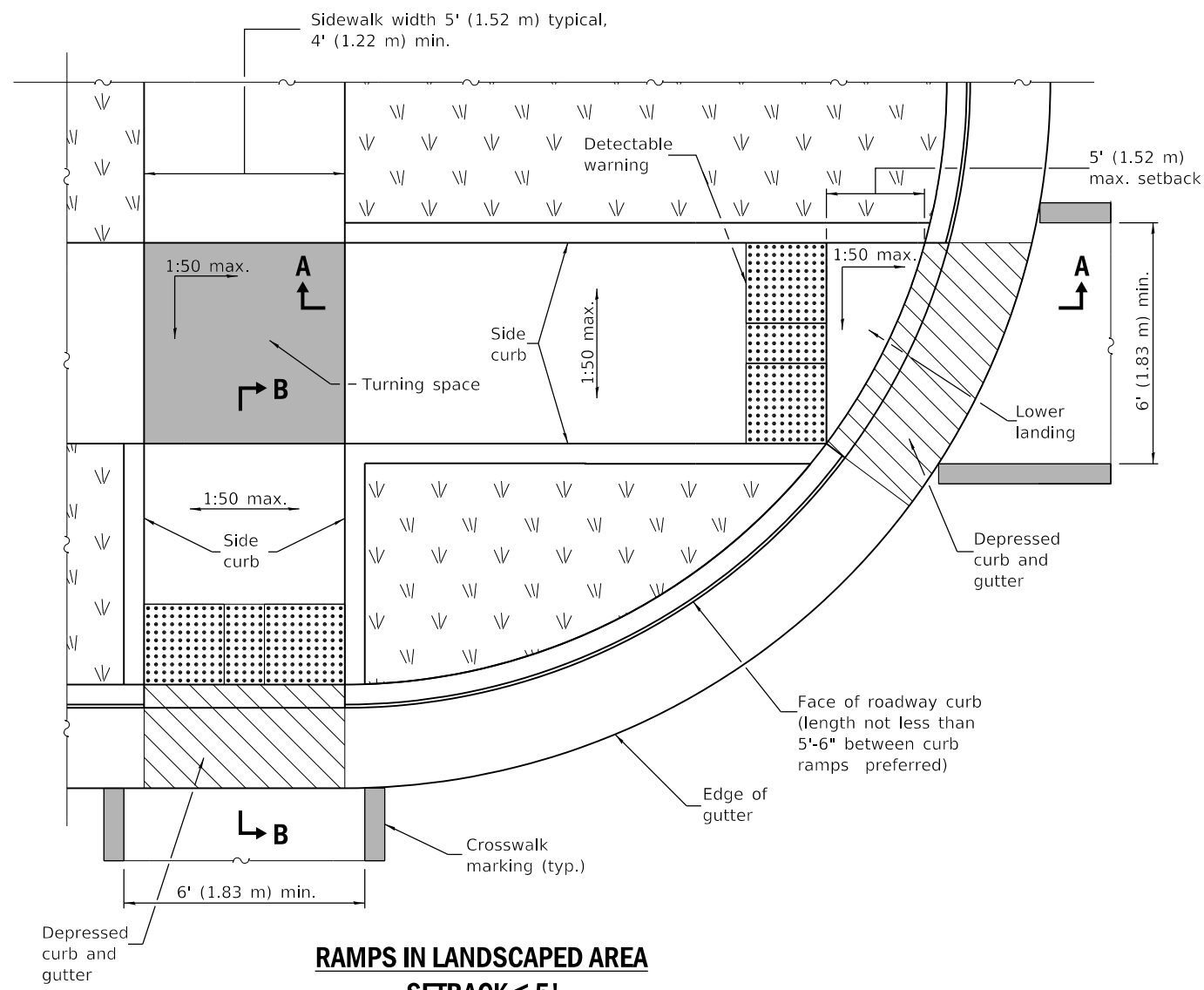

**RAMPS IN LANDSCAPED AREA
SETBACK ≤ 5'**

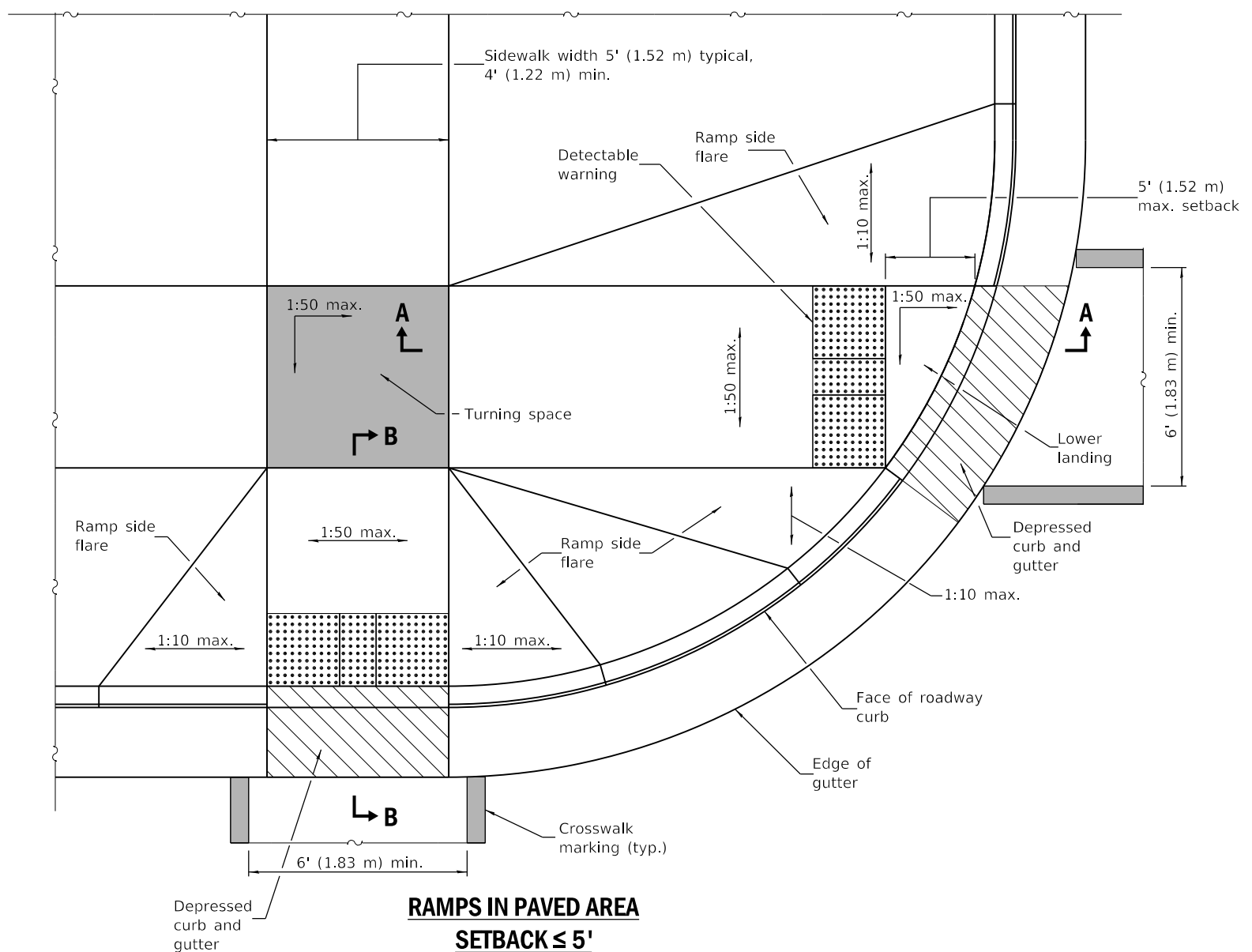

**RAMPS IN PAVED AREA
SETBACK ≤ 5'**

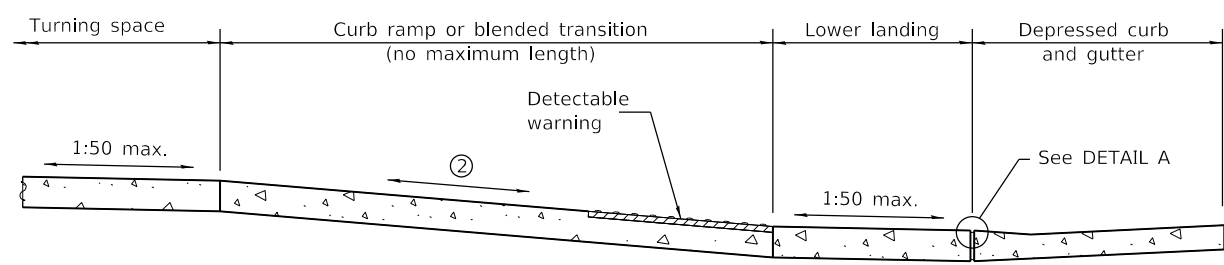

SECTION A-A

② The running slope of a curb ramp shall be 1:20 min. and 1:12 max. The running slope of a blended transition shall be 1:20 max.

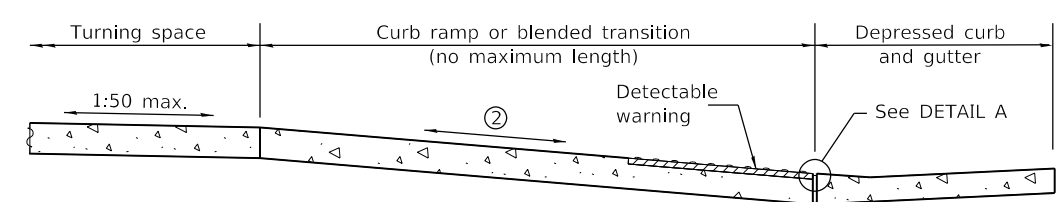

SECTION B-B

② The running slope of a curb ramp shall be 1:20 min. and 1:12 max. The running slope of a blended transition shall be 1:20 max.

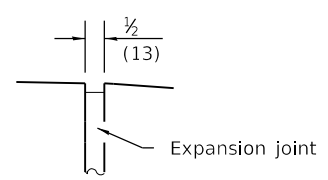

DETAIL A

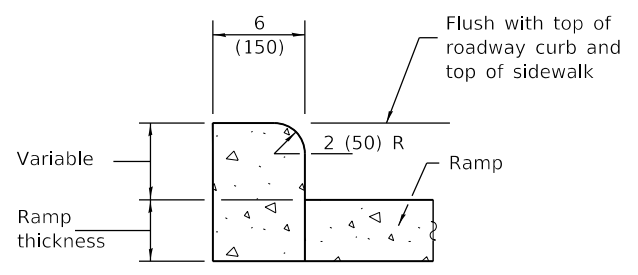

SIDE CURB DETAIL

Illinois Department of Transportation

PASSED January 1, 2019
Michael Bond
 ENGINEER OF POLICY AND PROCEDURES

APPROVED January 1, 2019
J. E. C.
 ENGINEER OF DESIGN AND ENVIRONMENT

ISSUED 1-1-97

DATE	REVISIONS
1-1-19	Removed "15-foot rule", added "Blended transitions" and placement tolerances for detectable warnings.
1-1-18	Omitted diagonal slope at turning spaces and lower landings.

See Sheet 2 for GENERAL NOTES.

**PERPENDICULAR CURB RAMPS
FOR SIDEWALKS**

(Sheet 1 of 2)

STANDARD 424001-11

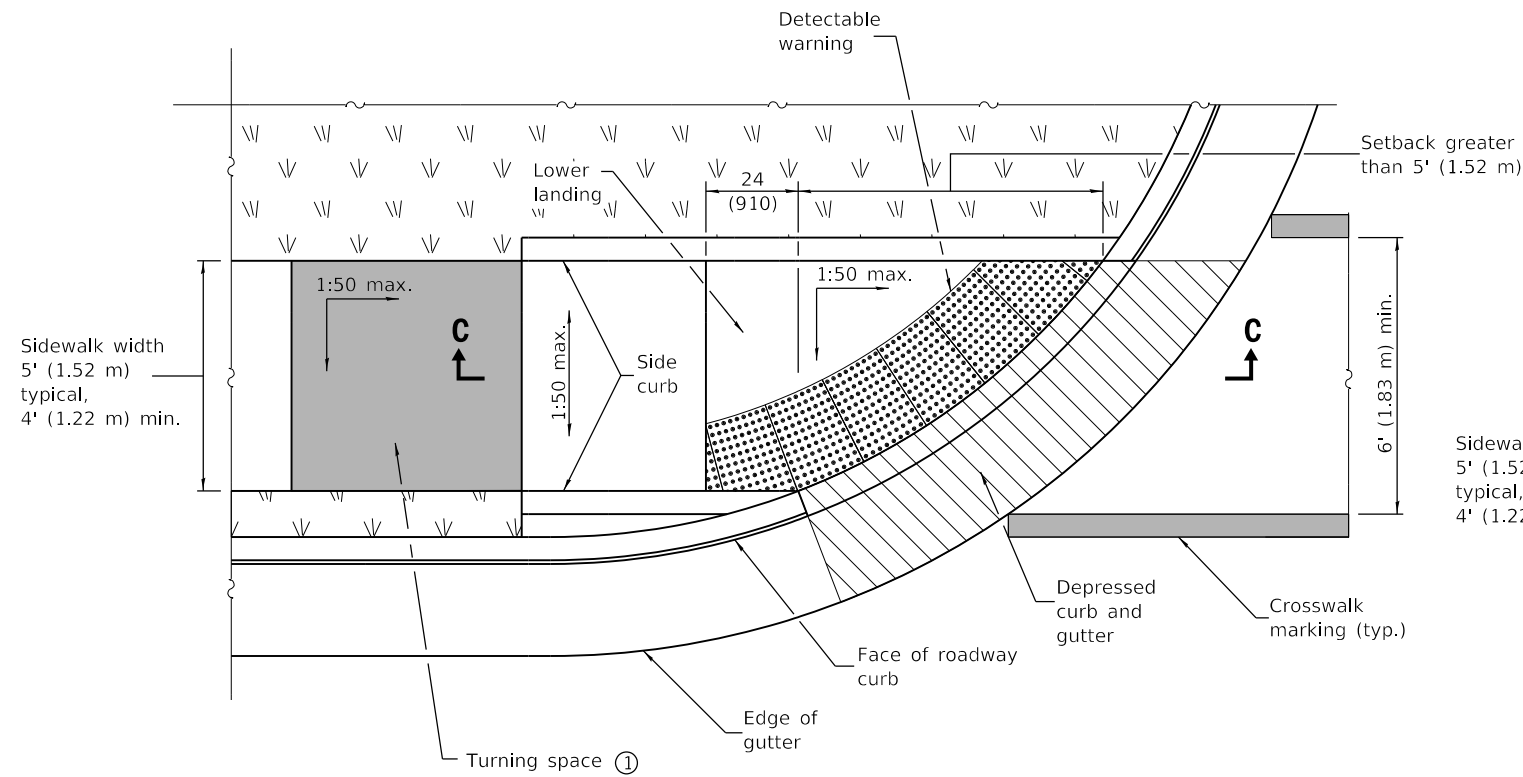

**RAMP IN LANDSCAPED AREA
SETBACK > 5'**

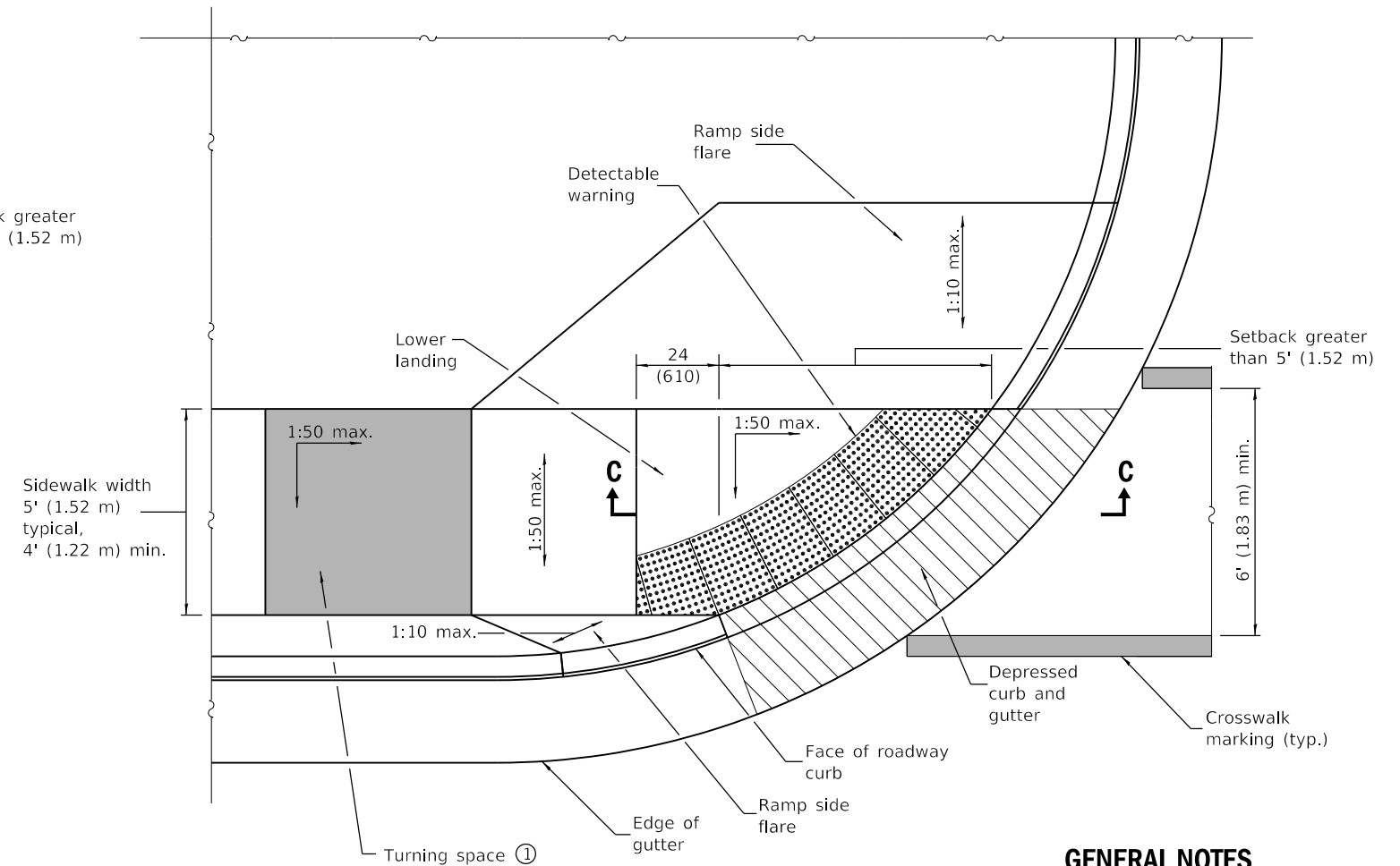

**RAMP IN PAVED AREA
SETBACK > 5'**

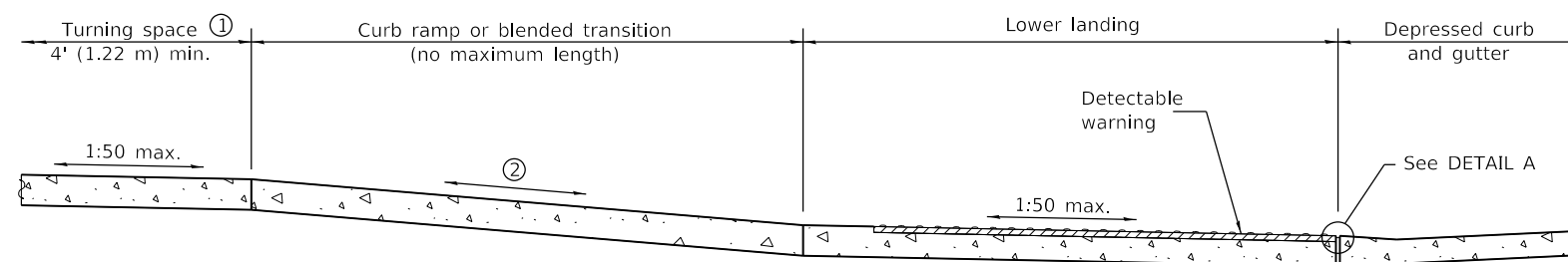

SECTION C-C

- ① This turning space not required for blended transitions.
- ② The running slope of a curb ramp shall be 1:20 min. and 1:12 max. The running slope of a blended transition shall be 1:20 max.

GENERAL NOTES

All slope ratios are expressed as units of vertical displacement to units of horizontal displacement (V:H).

Where the turning space is constrained on a side opposite a ramp, the minimum length of the turning space in the direction of the ramp-run shall be 5' (1.52 m).

Where 1:50 maximum slope is shown, 1:64 is preferred.

Detectable warnings are shown in their ideal locations but the following placement tolerances are allowed.

Side Border - Detectable warnings should extend the full width of the walking surface (excluding flared sides) but a border along each side up to 2 in. (50 mm) in width is allowed.

Curb Set-Back - Detectable warnings located at the back of curb should closely align with the curb but a gap up to 6 in. (150 mm) behind the curb is allowed.

See Standard 606001 for details of depressed curb adjacent to curb ramp.

All dimensions are in inches (millimeters) unless otherwise shown.

**PERPENDICULAR CURB RAMPS
FOR SIDEWALKS**

(Sheet 2 of 2)

STANDARD 424001-11

Illinois Department of Transportation

PASSED January 1, 2019
Michael Bond
 ENGINEER OF POLICY AND PROCEDURES

APPROVED January 1, 2019
Joe E. ...
 ENGINEER OF DESIGN AND ENVIRONMENT

ISSUED 1-1-97

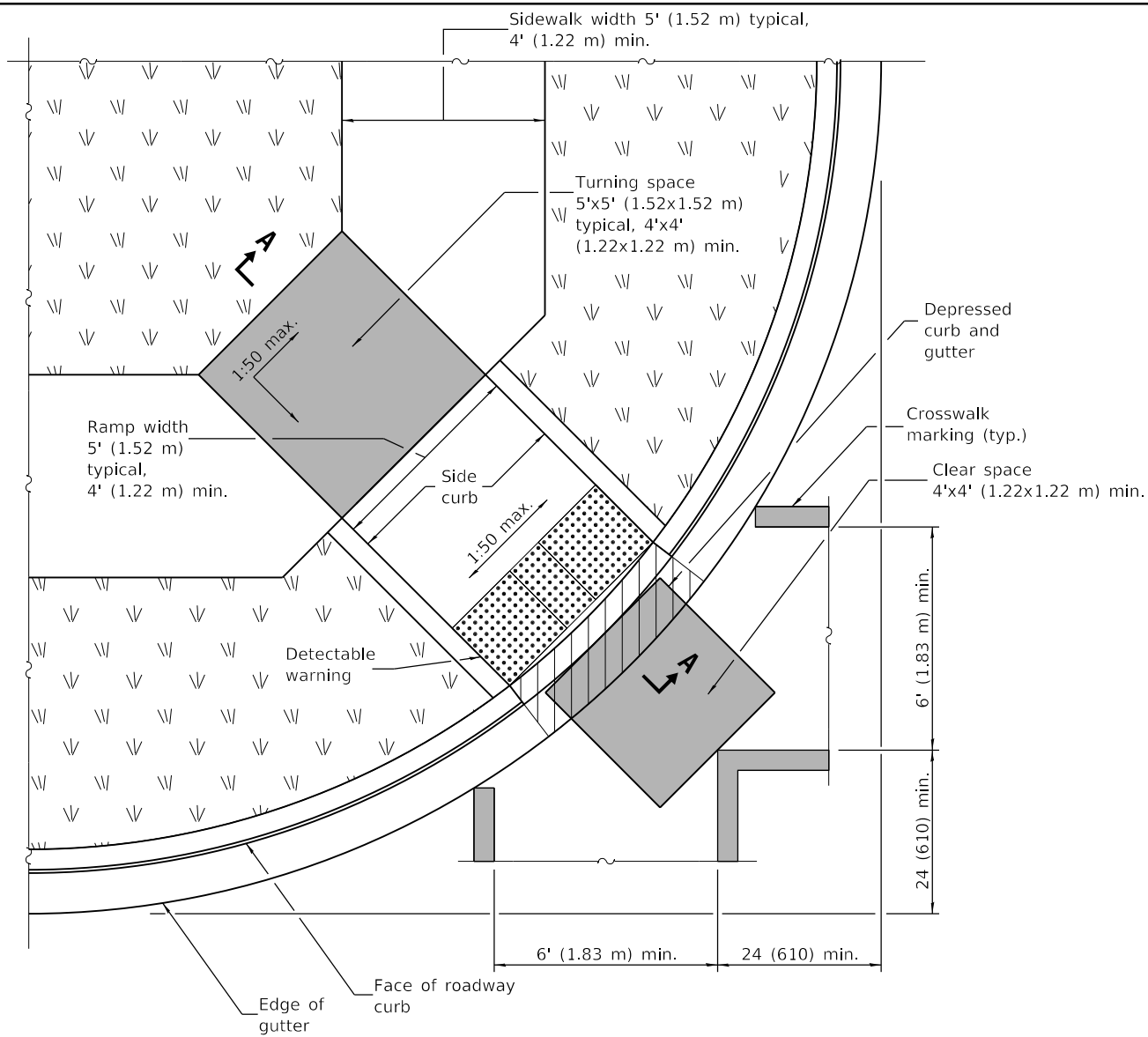

RAMP IN LANDSCAPED AREA

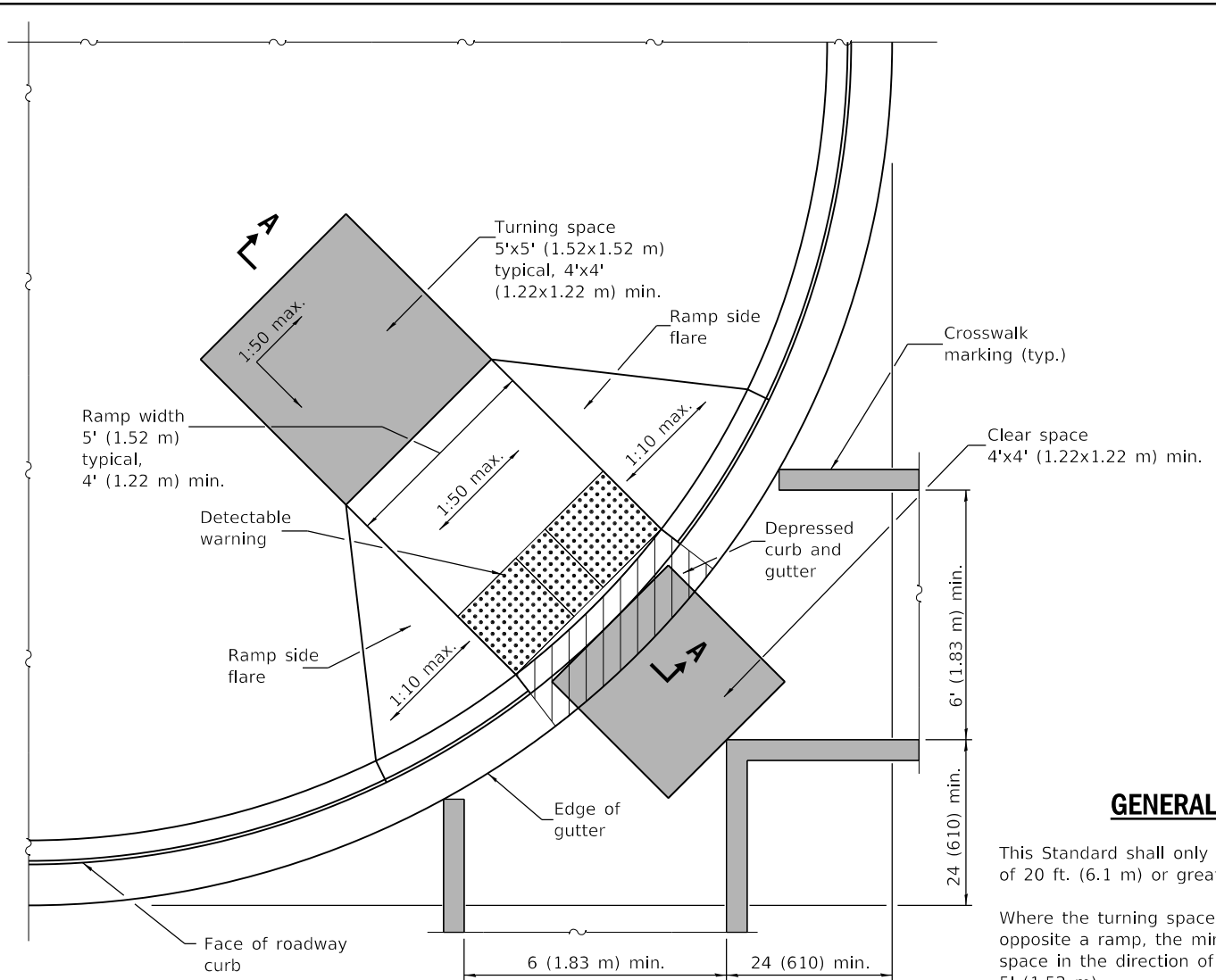

RAMP IN PAVED AREA

GENERAL NOTES

This Standard shall only be used for curb radii of 20 ft. (6.1 m) or greater.

Where the turning space is constrained on a side opposite a ramp, the minimum length of the turning space in the direction of the ramp-run shall be 5' (1.52 m).

Where 1:50 maximum slope is shown, 1:64 is preferred.

Detectable warnings are shown in their ideal locations but the following placement tolerances are allowed.

Side Border - Detectable warnings should extend the full width of the walking surface (excluding flared sides) but a border along each side up to 2 in. (50 mm) in width is allowed.

Curb Set-Back - Detectable warnings located at the back of curb should closely align with the curb but a gap up to 6 in. (150 mm) behind the curb is allowed.

All slope ratios are expressed as units of vertical displacement to units of horizontal displacement (V:H).

See Standard 606001 for details of depressed curb adjacent to curb ramp.

All dimensions are in inches (millimeters) unless otherwise shown.

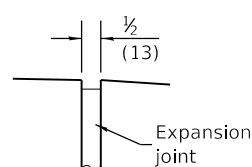

DETAIL A

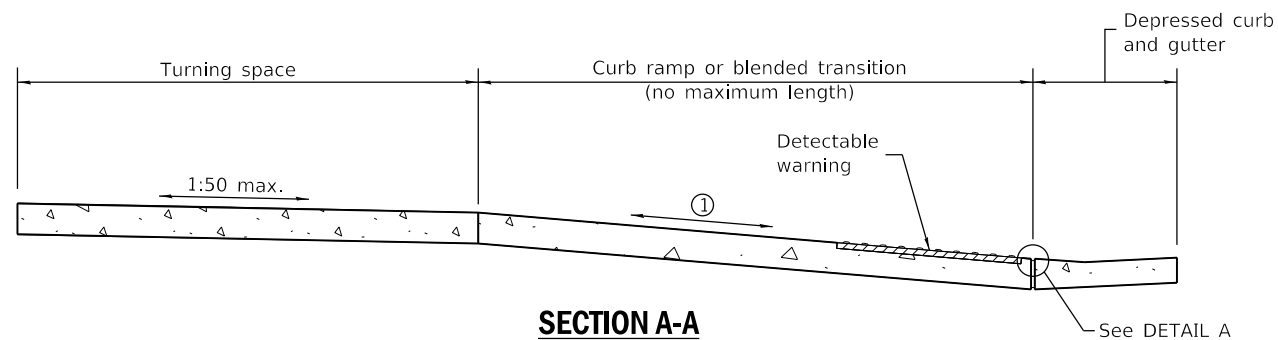

SECTION A-A

① The running slope of a curb ramp shall be 1:20 min. and 1:12 max. The running slope of a blended transition shall be 1:20 max.

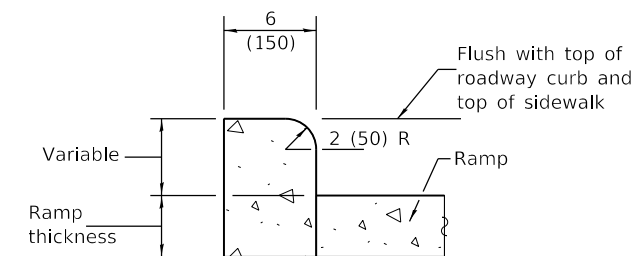

SIDE CURB DETAIL

DATE	REVISIONS
1-1-21	Clarified minimum crosswalk width and locations.
1-1-19	Removed "15-foot rule", added "blended transitions" and placement tolerances for detectable warnings.

DIAGONAL CURB RAMPS FOR SIDEWALKS

STANDARD 424006-05

Illinois Department of Transportation

PASSED January 1, 2021
Michael Bond
 ENGINEER OF POLICY AND PROCEDURES

APPROVED January 1, 2021
John E. ...
 ENGINEER OF DESIGN AND ENVIRONMENT

ISSUED 1-1-12

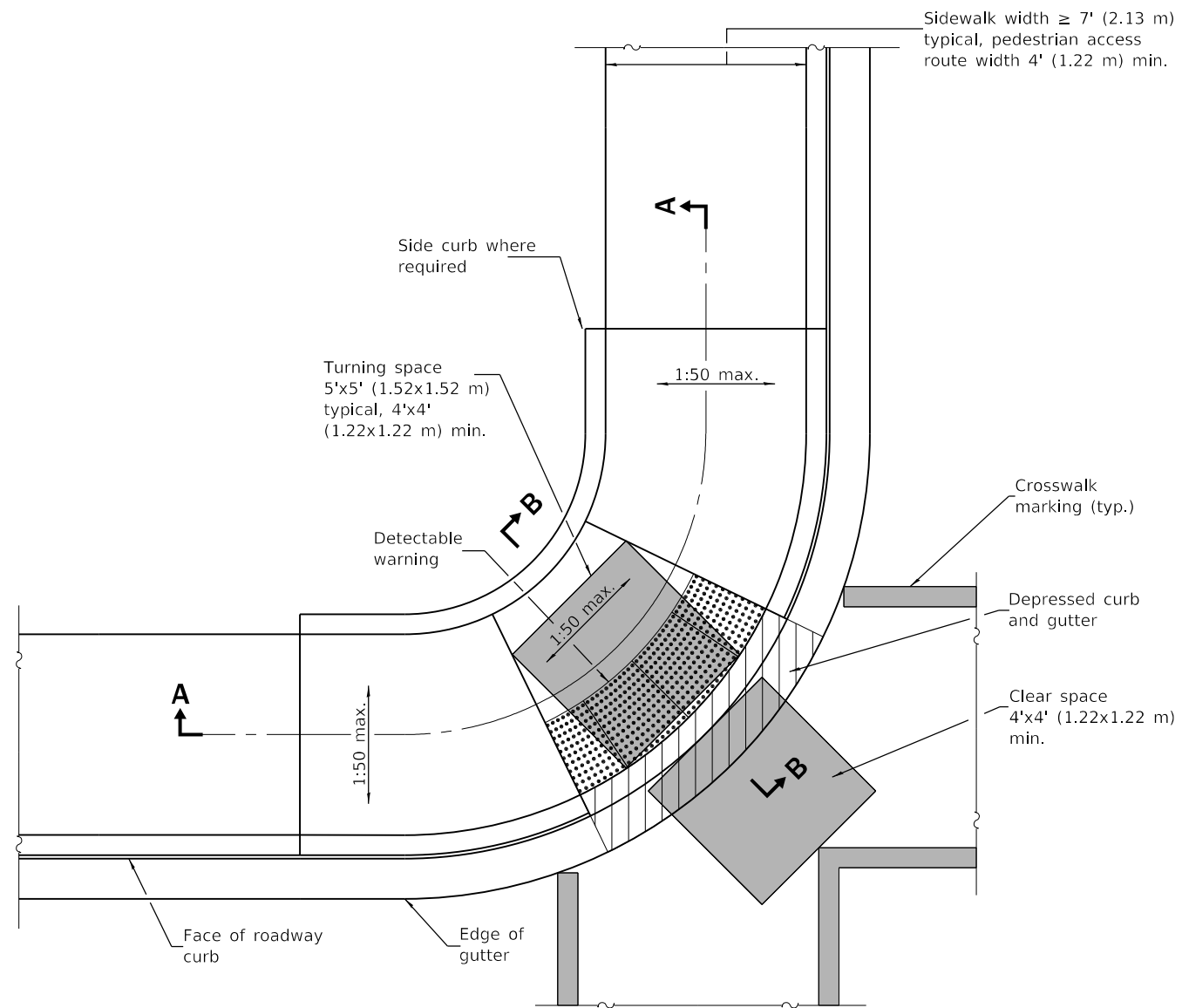

CORNER PARALLEL CURB RAMP

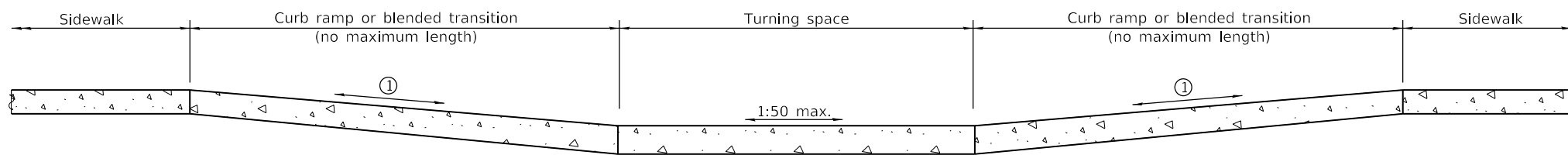

SECTION A-A

① The running slope of a curb ramp shall be 1:20 min. and 1:12 max. The running slope of a blended transition shall be 1:20 max.

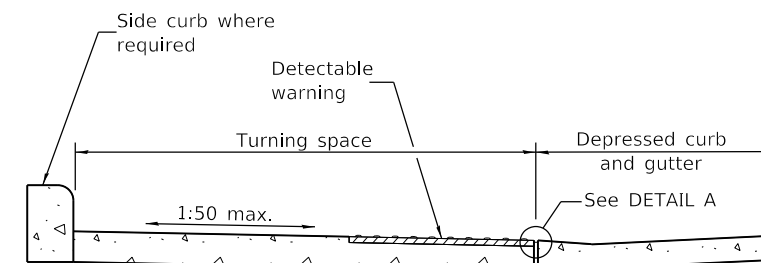

SECTION B-B

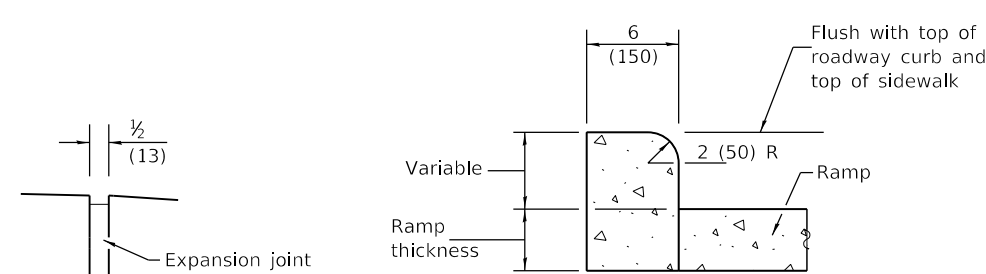

DETAIL A

SIDE CURB DETAIL

GENERAL NOTES

All slope ratios are expressed as units of vertical displacement to units of horizontal displacement (V:H).

Where the turning space is constrained on a side opposite a ramp, the minimum length of the turning space in the direction of the ramp-run shall be 5' (1.52 m).

Where 1:50 maximum slope is shown, 1:64 is preferred.

Detectable warnings are shown in their ideal locations but the following placement tolerances are allowed.

Side Border - Detectable warnings should extend the full width of the walking surface (excluding flared sides) but a border along each side up to 2 in. (50 mm) in width is allowed.

Curb Set-Back - Detectable warnings located at the back of curb should closely align with the curb but a gap up to 6 in. (150 mm) behind the curb is allowed.

See Standard 606001 for details of depressed curb adjacent to curb ramp.

All dimensions are in inches (millimeters) unless otherwise shown.

DATE	REVISIONS
1-1-19	Removed upper landing, added blended transition and detectable warning tolerances.
1-1-17	Revised sidewalk width to include 24 (610) buffer behind curb.

CORNER PARALLEL CURB RAMPS FOR SIDEWALKS

STANDARD 424011-04

Illinois Department of Transportation

PASSED January 1, 2019
Michael Bond
 ENGINEER OF POLICY AND PROCEDURES

APPROVED January 1, 2019
Joe E. ...
 ENGINEER OF DESIGN AND ENVIRONMENT

ISSUED 1-1-12

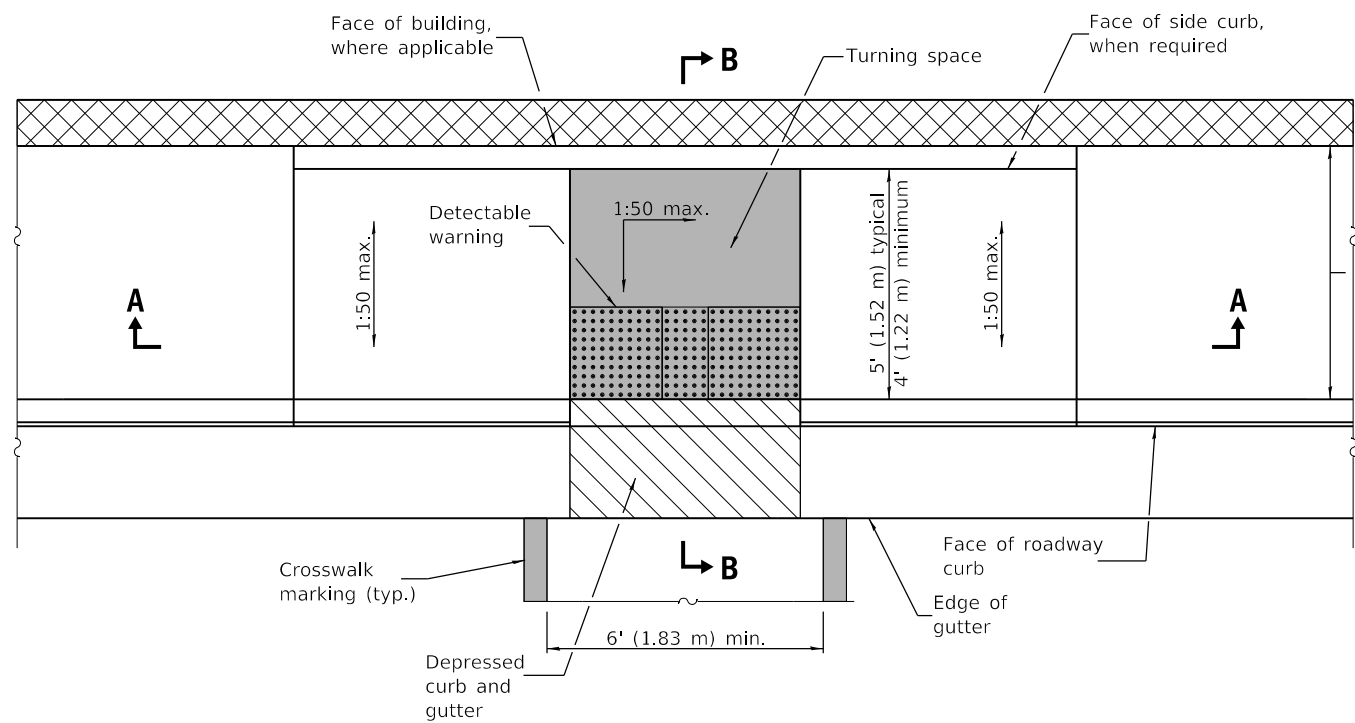

PARALLEL MID-BLOCK CURB RAMP

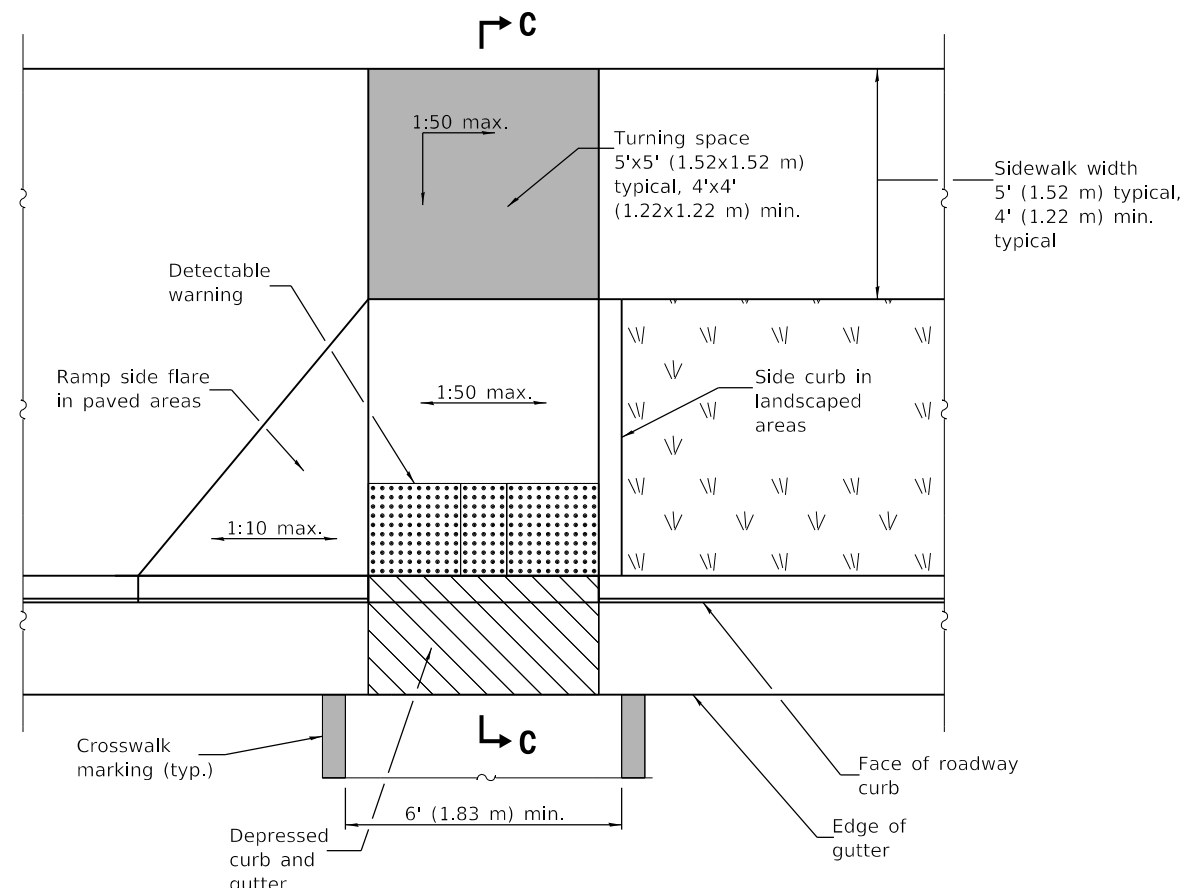

PERPENDICULAR MID-BLOCK CURB RAMP

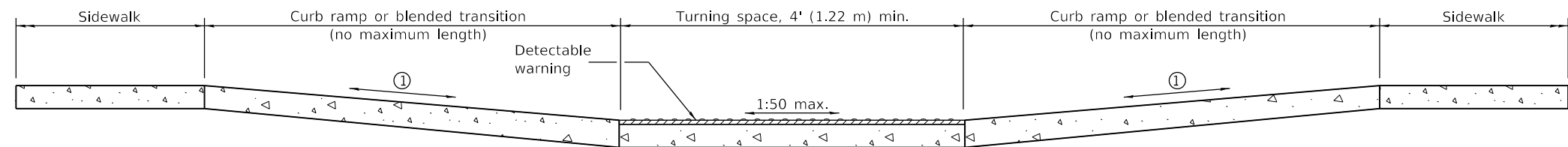

SECTION A-A

① The running slope of a curb ramp shall be 1:20 min. and 1:12 max. The running slope of a blended transition shall be 1:20 max.

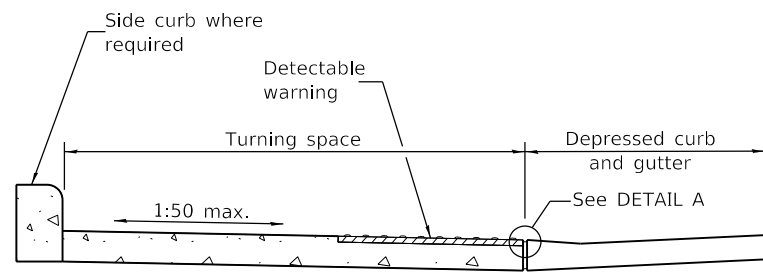

SECTION B-B

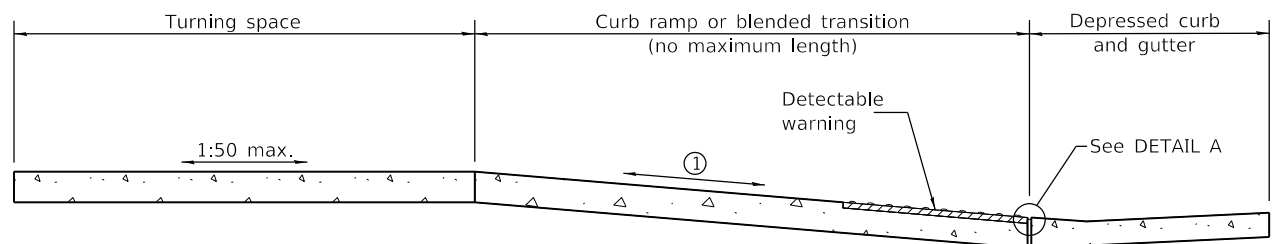

SECTION C-C

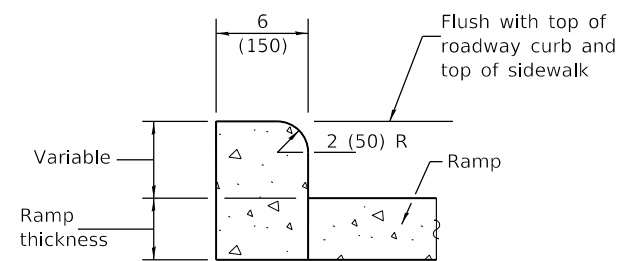

SIDE CURB DETAIL

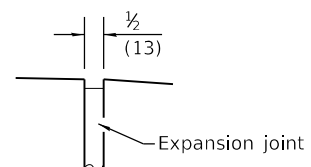

DETAIL A

GENERAL NOTES

All slope ratios are expressed as units of vertical displacement to units of horizontal displacement (V:H).

Where the turning space is constrained on a side opposite a ramp, the minimum length of the turning space in the direction of the ramp-run shall be 5' (1.52 m).

Where 1:50 maximum slope is shown, 1:64 is preferred.

Detectable warnings are shown in their ideal locations but the following placement tolerances are allowed.

Side Border - Detectable warnings should extend the full width of the walking surface (excluding flared sides) but a border along each side up to 2 in. (50 mm) in. width is allowed.

Curb Set-Back - Detectable warnings located at the back of curb should closely align with the curb but a gap up to 6 in. (150 mm) behind the curb is allowed.

See Standard 606001 for details of depressed curb adjacent to curb ramp.

All dimensions are in inches (millimeters) unless otherwise shown.

DATE	REVISIONS
1-1-19	Removed upper landing, added blended transitions and detectable warning tolerances.
1-1-18	Omitted diagonal slope at turning spaces and upper landings.

MID-BLOCK CURB RAMPS FOR SIDEWALKS

STANDARD 424016-05

Illinois Department of Transportation

PASSED January 1, 2019

ENGINEER OF POLICY AND PROCEDURES

APPROVED January 1, 2019

ENGINEER OF DESIGN AND ENVIRONMENT

ISSUED 1-1-12

Sidewalk width 5' (1.52 m) typical, 4' (1.22 m) min.

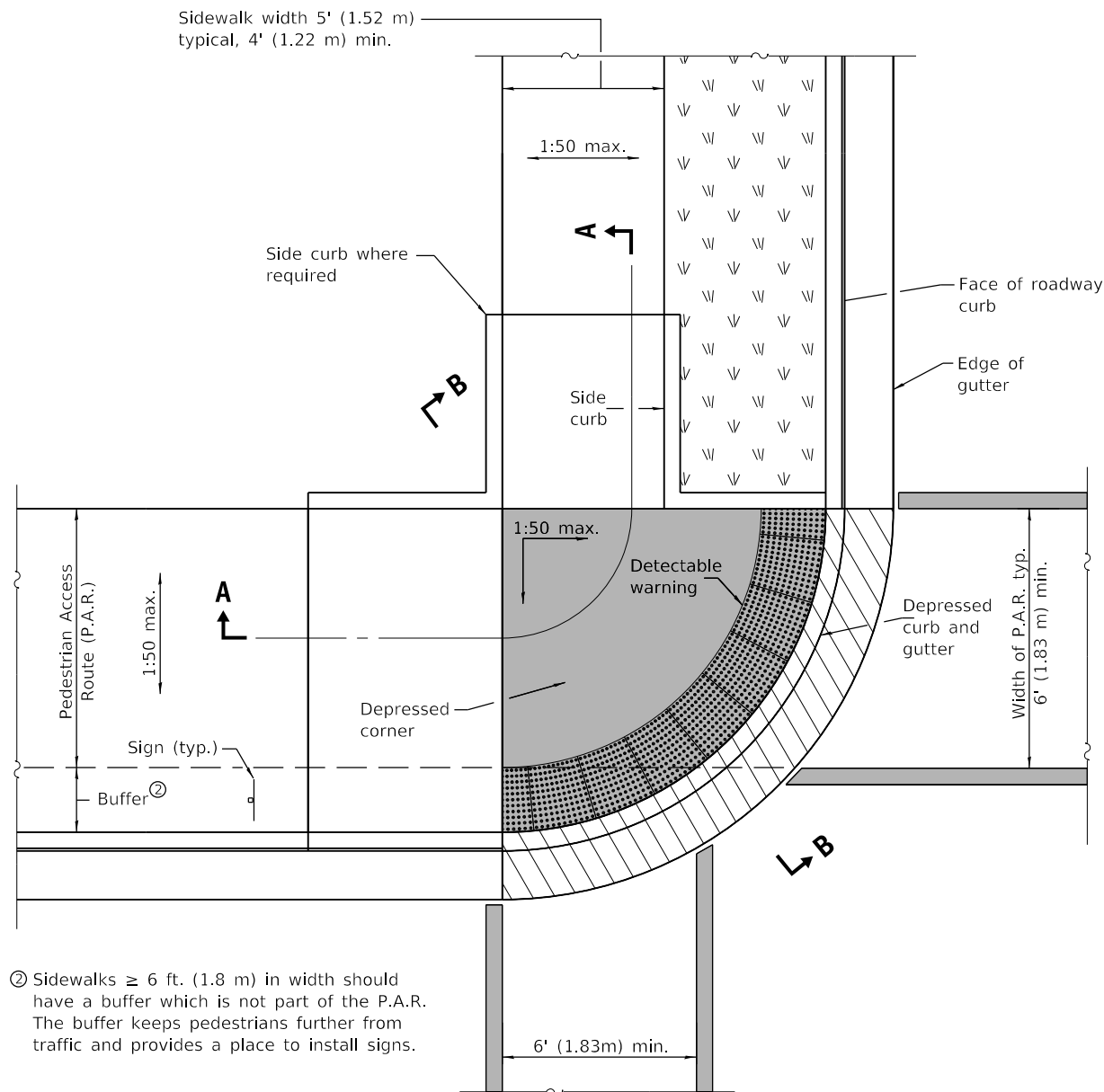

② Sidewalks \geq 6 ft. (1.8 m) in width should have a buffer which is not part of the P.A.R. The buffer keeps pedestrians further from traffic and provides a place to install signs.

DEPRESSED CORNER

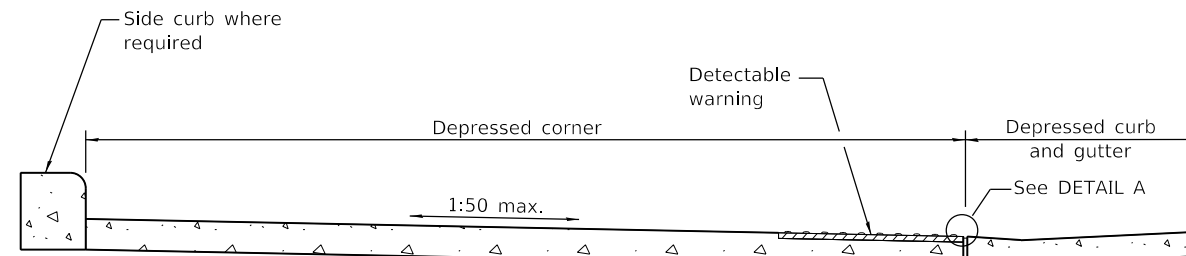

SECTION B-B

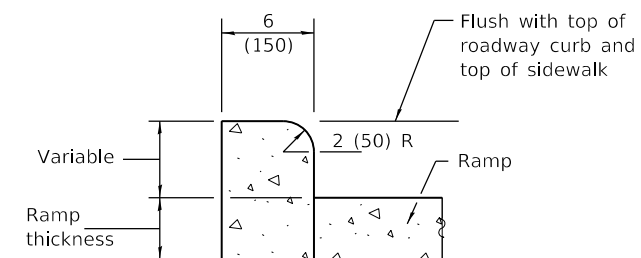

SIDE CURB DETAIL

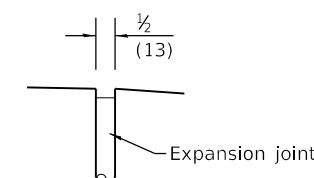

DETAIL A

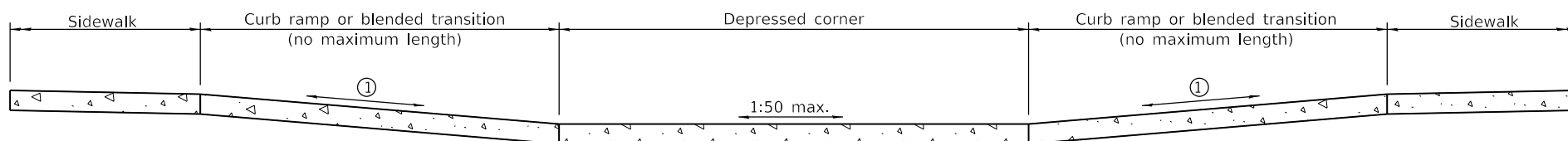

SECTION A-A

① The running slope of a curb ramp shall be 1:20 min. and 1:12 max. The running slope of a blended transition shall be 1:20 max.

GENERAL NOTES

This standard shall only be used for curb radii of 6 ft. (1.83 m) or greater.

All slope ratios are expressed as units of vertical displacement to units of horizontal displacement (V:H).

Where 1:50 maximum slope is shown, 1:64 is preferred.

Detectable warnings are shown in their ideal tolerances but the following placement tolerances are allowed.

Side Border - Detectable warnings should extend the full width of the walking surface (excluding flared sides) but a border along each side up to 2 in. (50 mm) in. width is allowed.

Curb Set-Back - Detectable warnings located at the back of curb should closely align with the curb but a gap up to 6 in. (150 mm) behind the curb is allowed.

See Standard 606001 for details of depressed curb adjacent to curb ramp.

All dimensions are in inches (millimeters) unless otherwise shown.

DATE	REVISIONS
1-1-21	Added crosswalk striping and a "buffer" for wide sidewalks.
1-1-19	Removed upper landings, added blended transition and detectable warning tolerances.

DEPRESSED CORNER FOR SIDEWALKS

STANDARD 424021-06

Illinois Department of Transportation

PASSED January 1, 2021
Michael Bond
 ENGINEER OF POLICY AND PROCEDURES

APPROVED January 1, 2021
J. E. ...
 ENGINEER OF DESIGN AND ENVIRONMENT

ISSUED 1-1-12

- ② Detectable warning shall only be installed at entrances/alleys with permanent traffic control devices (i.e. stop signs, signals).
- ③ Where possible, maintain the grade of the sidewalk across the entrance/alley to avoid the need for ramps and turning spaces.

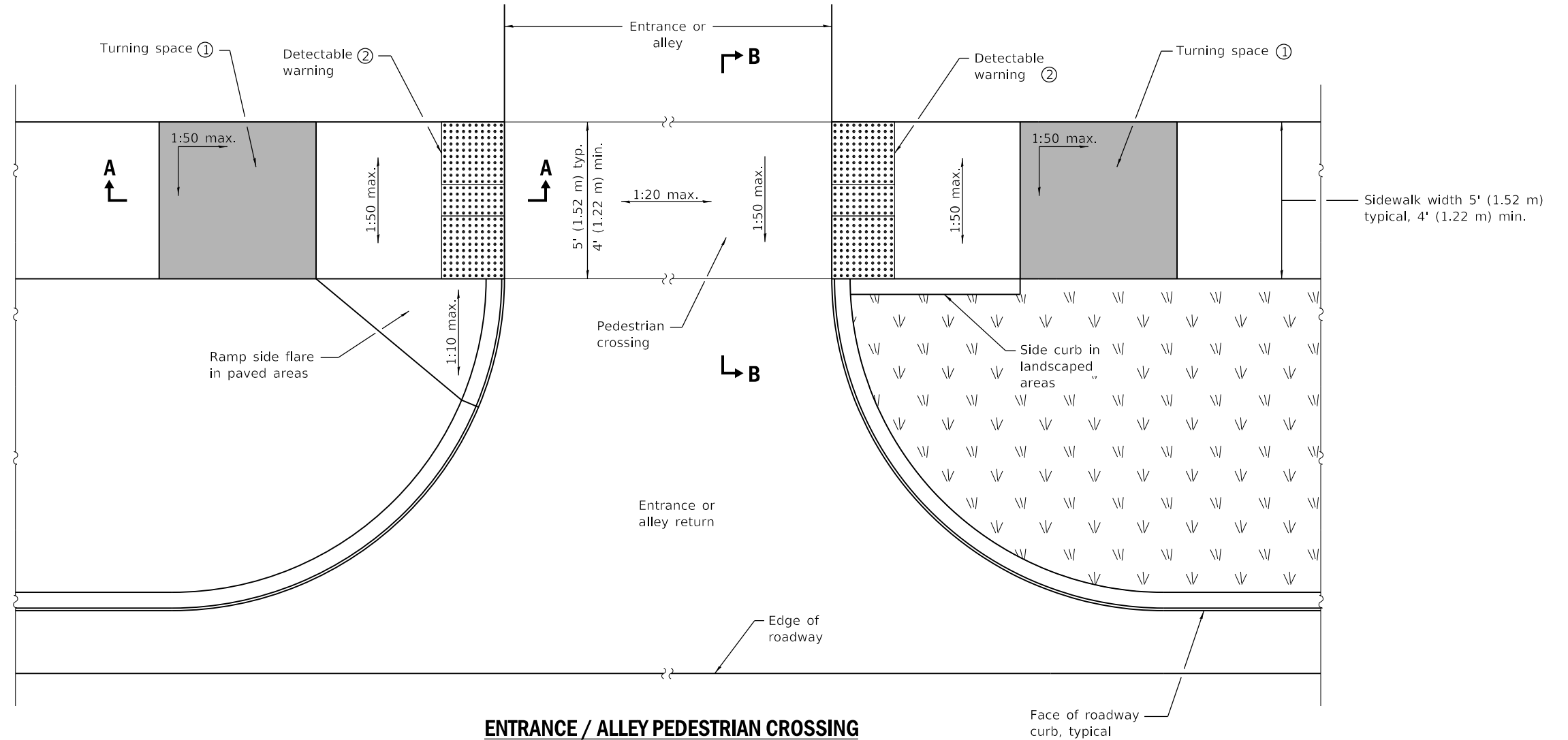

ENTRANCE / ALLEY PEDESTRIAN CROSSING

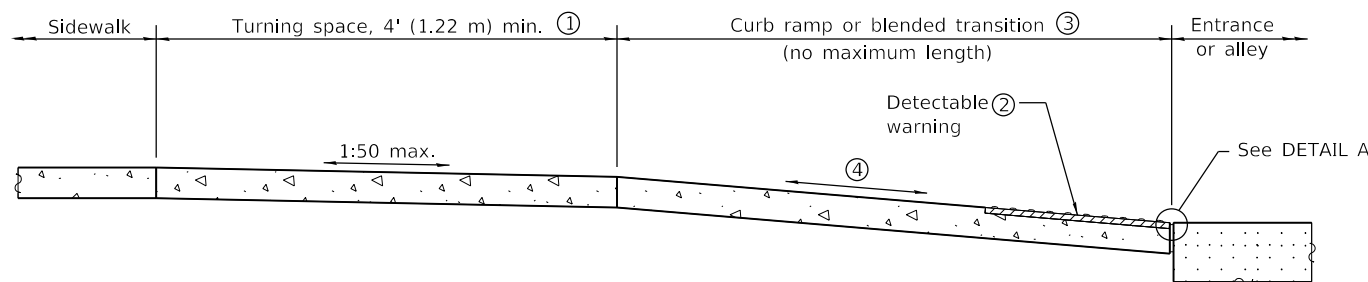

SECTION A-A

- ① Turning space not required for blended transitions.
- ④ The running slope of a curb ramp shall be 1:20 min and 1:12 max. The running slope of a blended transition shall be 1:20 max.

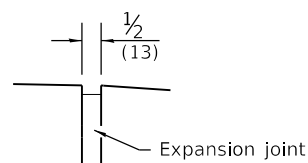

DETAIL A

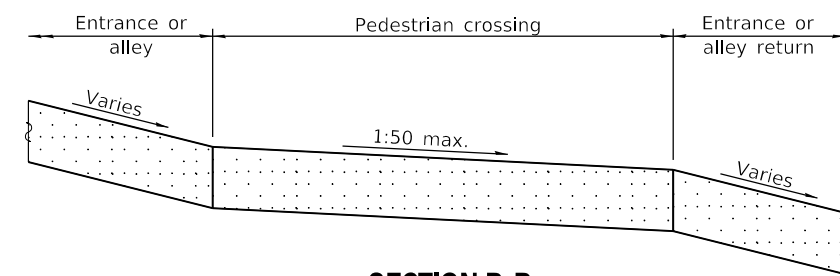

SECTION B-B

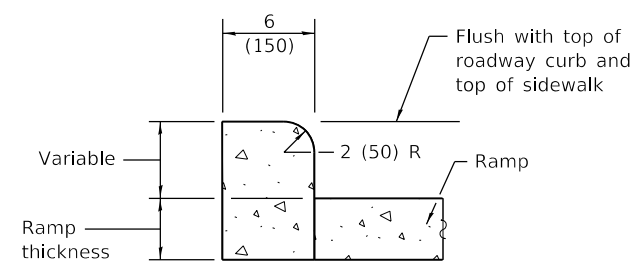

SIDE CURB DETAIL

GENERAL NOTES

All slope ratios are expressed as units of vertical displacement to units of horizontal displacement (V:H).

Where 1:50 maximum slope is shown, 1:64 is preferred.

Detectable warnings are shown in their ideal locations but the following placement tolerances are allowed.

Side Border - Detectable warnings should extend the full width of the walking surface (excluding flared sides) but a border along each side up to 2 in. (50 mm) in width is allowed.

Curb Set-Back - Detectable warnings located at the back of curb should closely align with the curb but a gap up to 6 in. (150 mm) behind the curb is allowed.

All dimensions are in inches (millimeters) unless otherwise shown.

DATE	REVISIONS
1-1-19	Added blended transitions and placement tolerances for detectable warnings.
1-1-18	Omitted diagonal slope at upper landings.

ENTRANCE / ALLEY PEDESTRIAN CROSSINGS

STANDARD 424026-03

Illinois Department of Transportation

PASSED January 1, 2019
Michael Bond
 ENGINEER OF POLICY AND PROCEDURES

APPROVED January 1, 2019
Joe E. ...
 ENGINEER OF DESIGN AND ENVIRONMENT

ISSUED 1-1-12

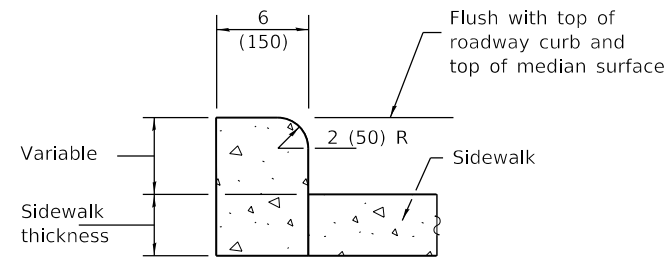

SIDE CURB DETAIL

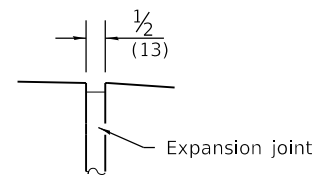

DETAIL A

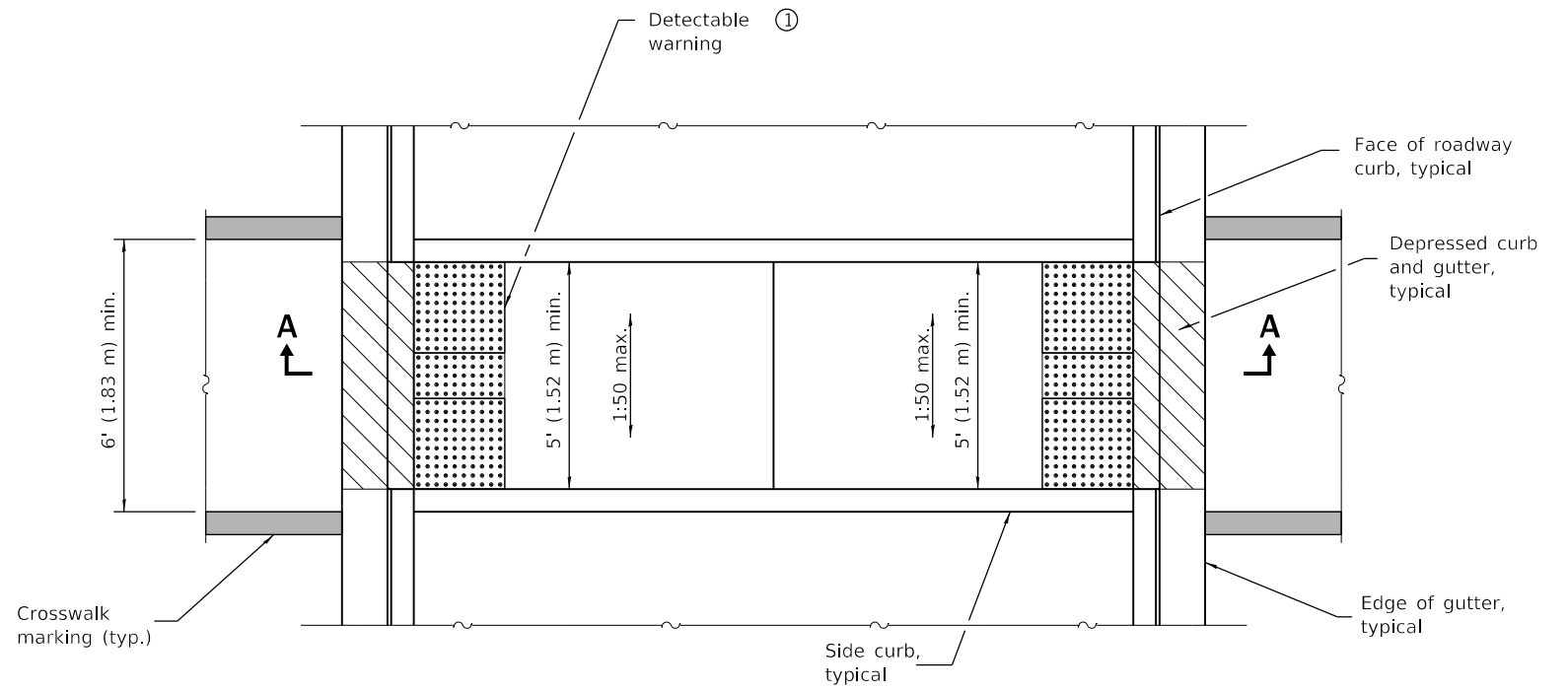

MEDIAN PEDESTRIAN CROSSING

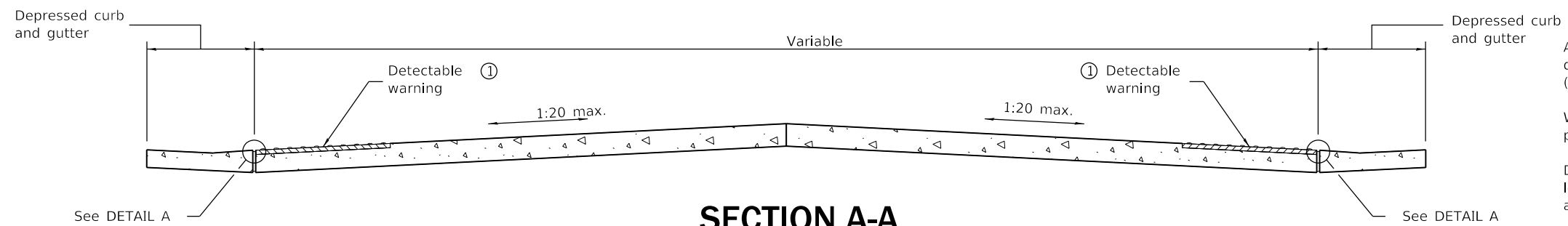

SECTION A-A

① Omit detectable warnings when distance between back of curbs is less than 6' (1.83 m).

GENERAL NOTES

All slope ratios are expressed as units of vertical displacement to units of horizontal displacement (V:H).

Where 1:50 maximum slope is shown, 1:64 is preferred.

Detectable warnings are shown in their ideal locations but the following placement tolerances are allowed.

Side Border - Detectable warnings should extend the full width of the walking surface (excluding flared sides) but a border along each side up to 2 in. (50 mm) in width is allowed.

Curb Set-Back - Detectable warnings located at the back of curb should closely align with the curb but a gap up to 6 in. (150 mm) behind the curb is allowed.

See Standard 606001 for details of depressed curb adjacent to curb ramp.

All dimensions are in inches (millimeters) unless otherwise shown.

Illinois Department of Transportation

PASSED January 1, 2019
Michael Bond
 ENGINEER OF POLICY AND PROCEDURES

APPROVED January 1, 2019
John E. ...
 ENGINEER OF DESIGN AND ENVIRONMENT

ISSUED 1-1-12

DATE	REVISIONS
1-1-19	Added placement tolerances for detectable warnings.
1-1-12	Widened crosswalk to 6' (1.83 m) min. inside dimension.
	Revised General Notes.

MEDIAN PEDESTRIAN CROSSINGS

STANDARD 424031-02

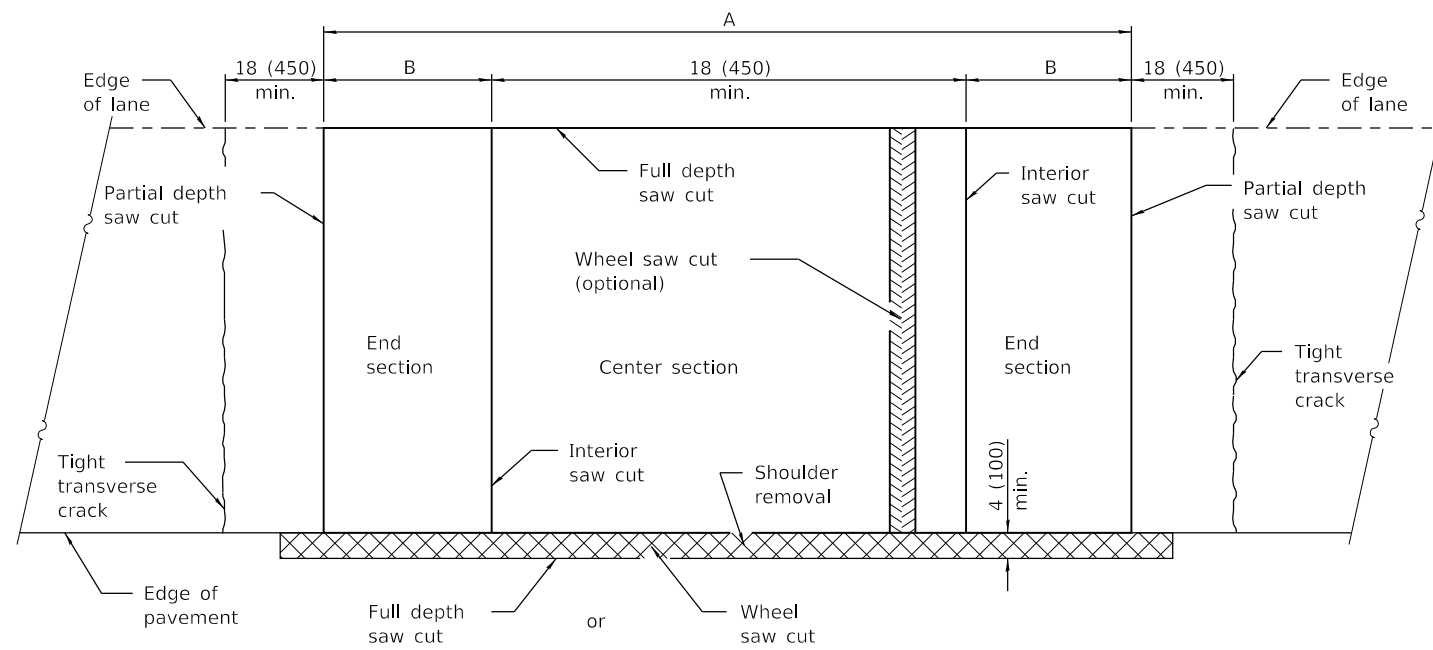

PAVEMENT SAWING DETAIL
(HMA SHOULDER)

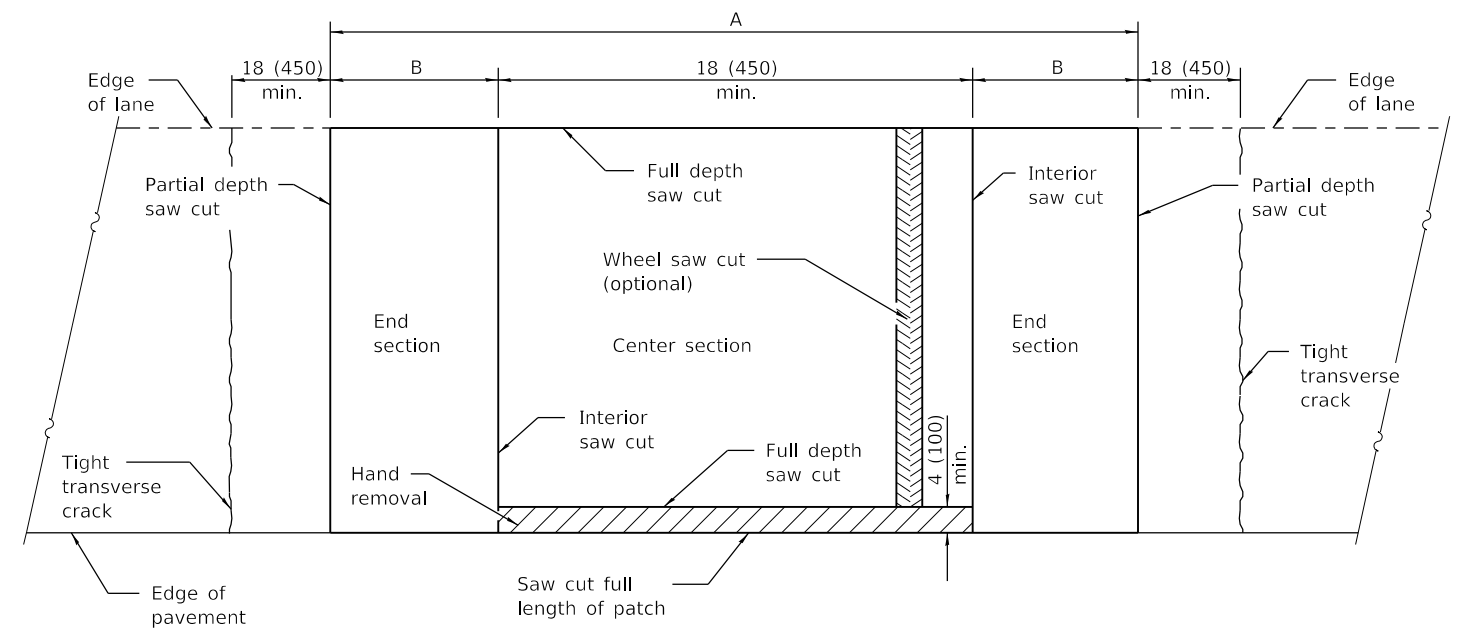

PAVEMENT SAWING DETAIL
(PCC SHOULDER)

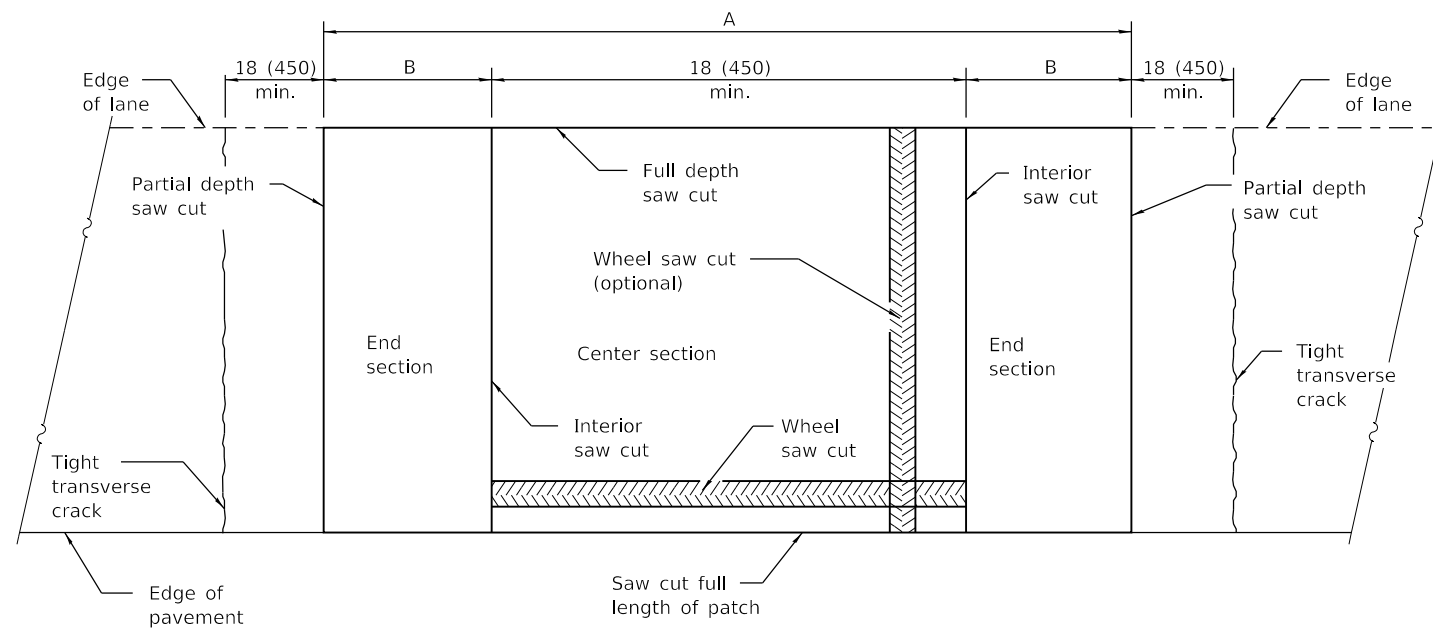

ALTERNATE SAWING DETAIL
(PCC SHOULDER)

EXISTING REINFORCEMENT BARS	A (min.)	B (min.)	C (min.)
No. 5 (No. 16)	4'-6" (1.4 m)	18 (450)	16 (400)
No. 6 (No. 19)	5'-0" (1.5 m)	21 (525)	19 (475)
No. 7 (No. 22)	5'-6" (1.7 m)	24 (600)	22 (550)
Fabric	5'-0" (1.5 m)	21 (525)	18 (450)

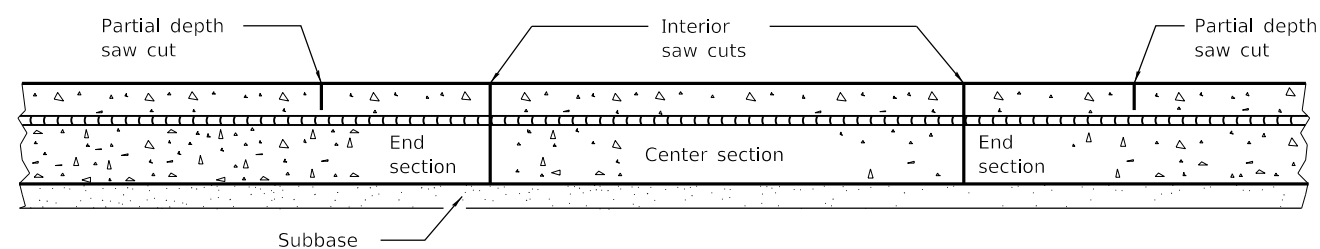

SAW CUT DETAIL

GENERAL NOTES

When patching two adjacent lanes in one operation, the longitudinal joint shall be a longitudinal sawed joint as detailed on Standard 420001; however, the groove may be either preformed or sawed.

All dimensions are in inches (millimeters) unless otherwise shown.

DATE	REVISIONS
1-1-08	Switched units to English (metric).
1-1-07	Revised General Notes.

CLASS A PATCHES

(Sheet 1 of 2)

STANDARD 442001-04

Illinois Department of Transportation

PASSED January 1, 2008
[Signature]
 ENGINEER OF POLICY AND PROCEDURES

APPROVED January 1, 2008
[Signature]
 ENGINEER OF DESIGN AND ENVIRONMENT

ISSUED 1-1-97

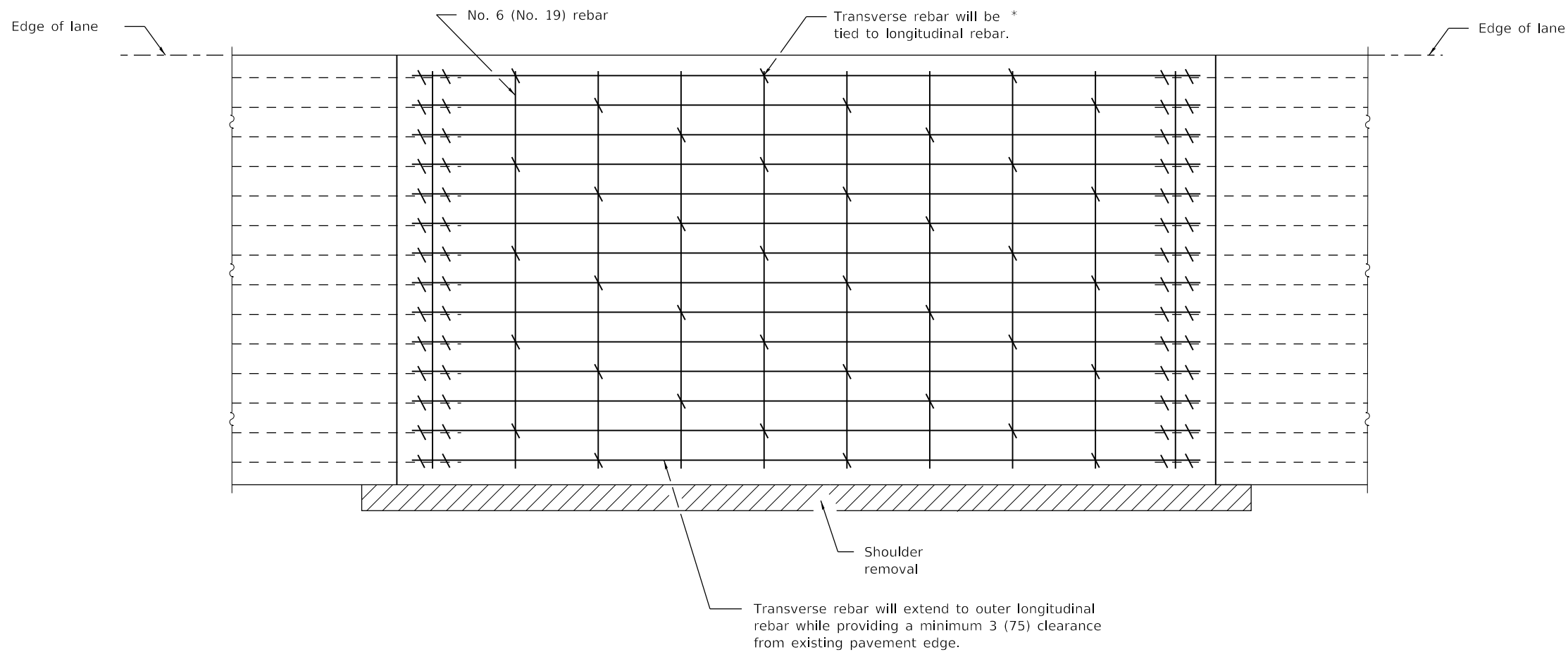

PAVEMENT REINFORCEMENT DETAIL

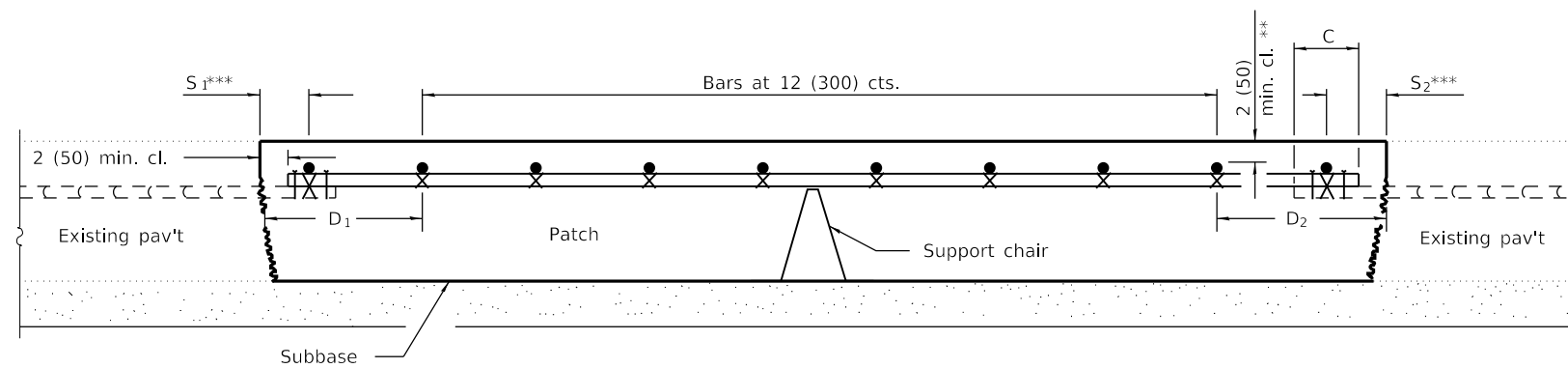

PATCHING DETAIL

- * Every 3rd intersection must be tied.
- ** When the minimum clearance cannot be obtained with the transverse bar on top then the transverse rebar shall be tied to the bottom of the longitudinal rebar.
- *** Variable: Where S_1 and S_2 are $2\frac{1}{2}$ (65) min. and 12 (300) max. $D_1 = 2(S_1)$ and $D_2 = 2(S_2)$.

Illinois Department of Transportation

PASSED January 1, 2008
[Signature]
 ENGINEER OF POLICY AND PROCEDURES

APPROVED January 1, 2008
[Signature]
 ENGINEER OF DESIGN AND ENVIRONMENT

ISSUED 1-1-97

CLASS A PATCHES

(Sheet 2 of 2)

STANDARD 442001-04

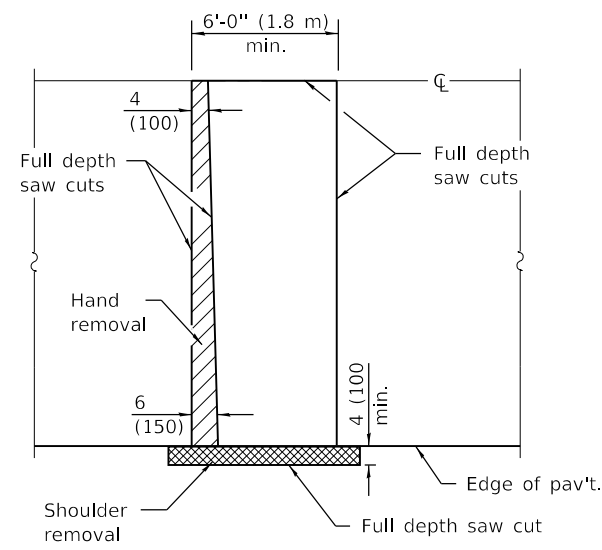

PAVEMENT SAWING DETAIL
(HMA SHOULDER)

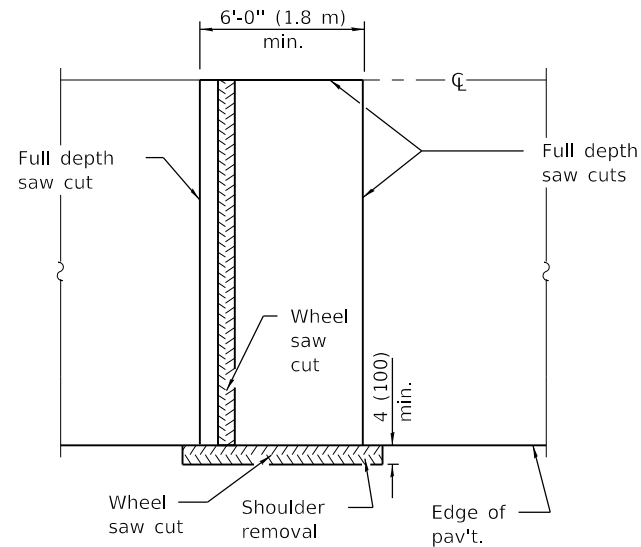

ALTERNATE SAWING DETAIL
(HMA SHOULDER)

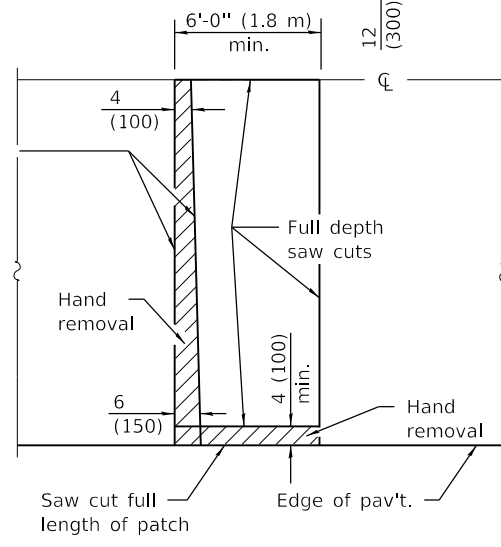

PAVEMENT SAWING DETAIL
(PCC SHOULDER)

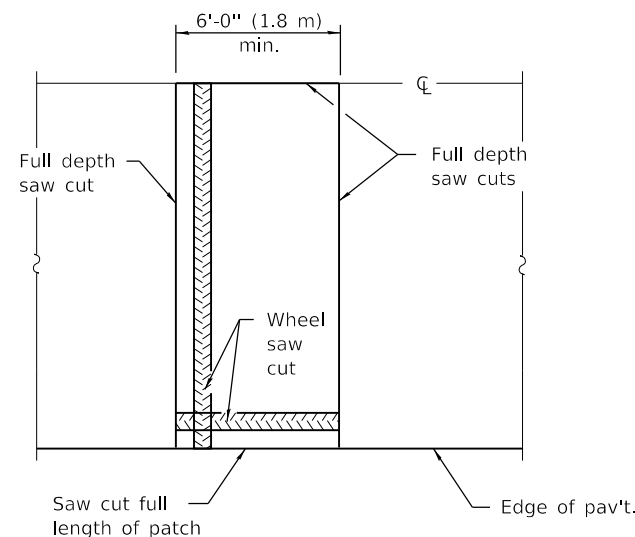

ALTERNATE SAWING DETAIL
(PCC SHOULDER)

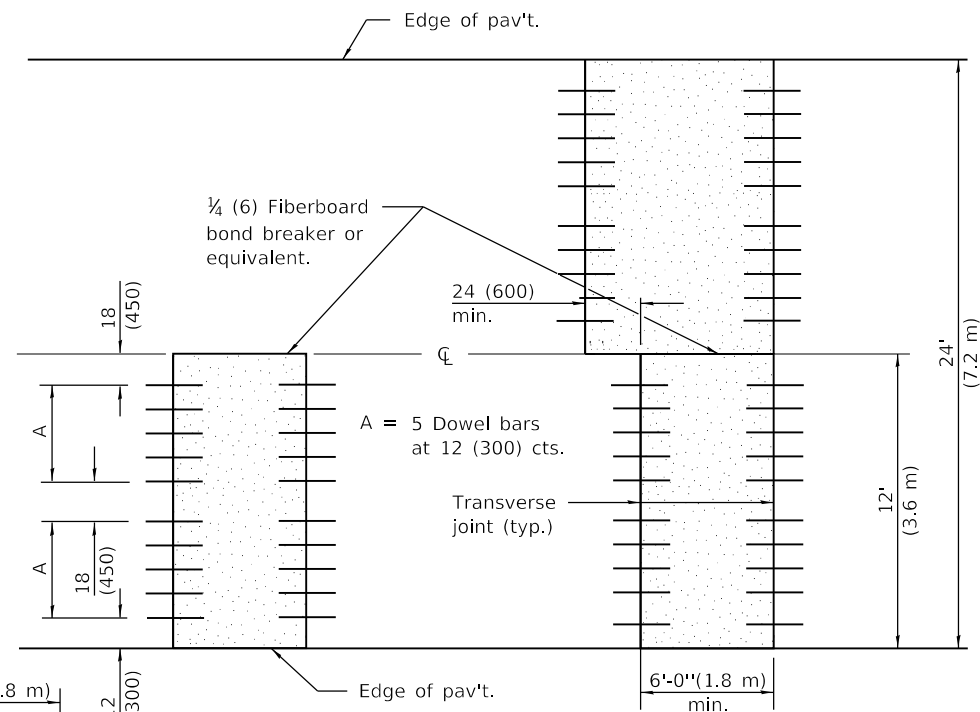

12' (3.6 m) WIDE LANES

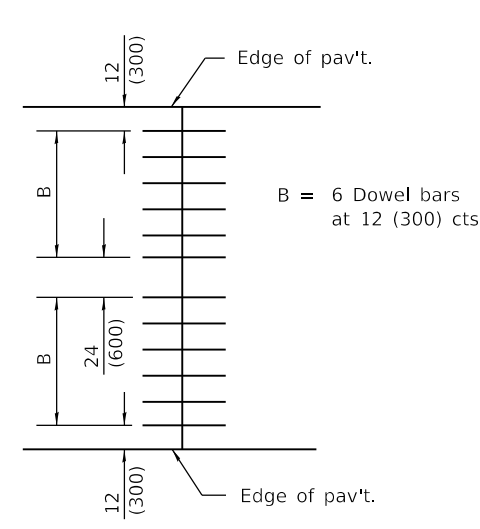

14' (4.2 m) WIDE RAMP

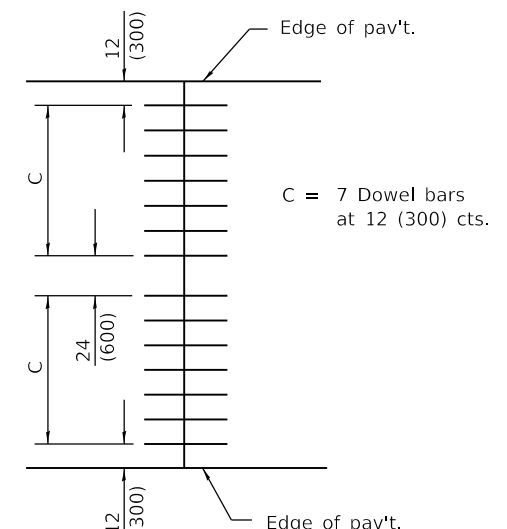

16' (4.8 m) WIDE RAMP

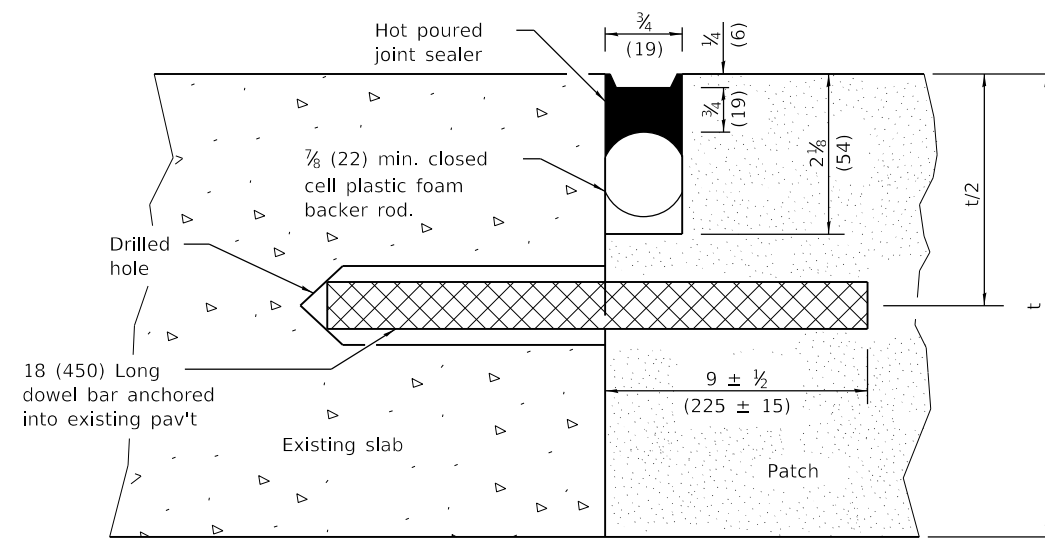

TRANSVERSE JOINT

DOWEL BAR TABLE		
PAVEMENT THICKNESS	DOWEL BAR DIAMETER	HOLE DIAMETER
10 (250) or greater	1 1/2 (38)	1 3/8 (41)
8 (200) thru 9.99 (249)	1 1/4 (32)	1 3/8 (35)
Less than 8 (200)	1 (25)	1 1/8 (29)

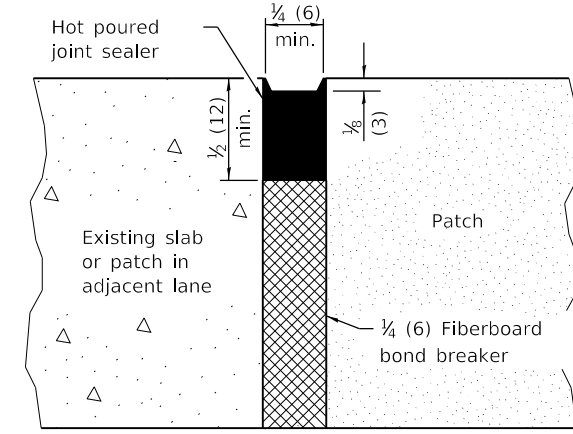

CENTERLINE JOINT

GENERAL NOTES

The transverse joints for Class B patches shall align with joints or cracks in the adjacent lane whenever possible.

See Standard 420701 for details of welded wire reinforcement.

All dimensions are in inches (millimeters) unless otherwise shown.

Illinois Department of Transportation

PASSED January 1, 2019

ENGINEER OF POLICY AND PROCEDURES

APPROVED January 1, 2019

ENGINEER OF DESIGN AND ENVIRONMENT

ISSUED 1-1-19

DATE	REVISIONS
1-1-19	Revised reference to Standard 420701 in General Notes.
1-1-18	Revised DOWEL BAR TABLE.

CLASS B PATCHES

(Sheet 1 of 2)

STANDARD 442101-09

TRANSVERSE EXPANSION JOINTS

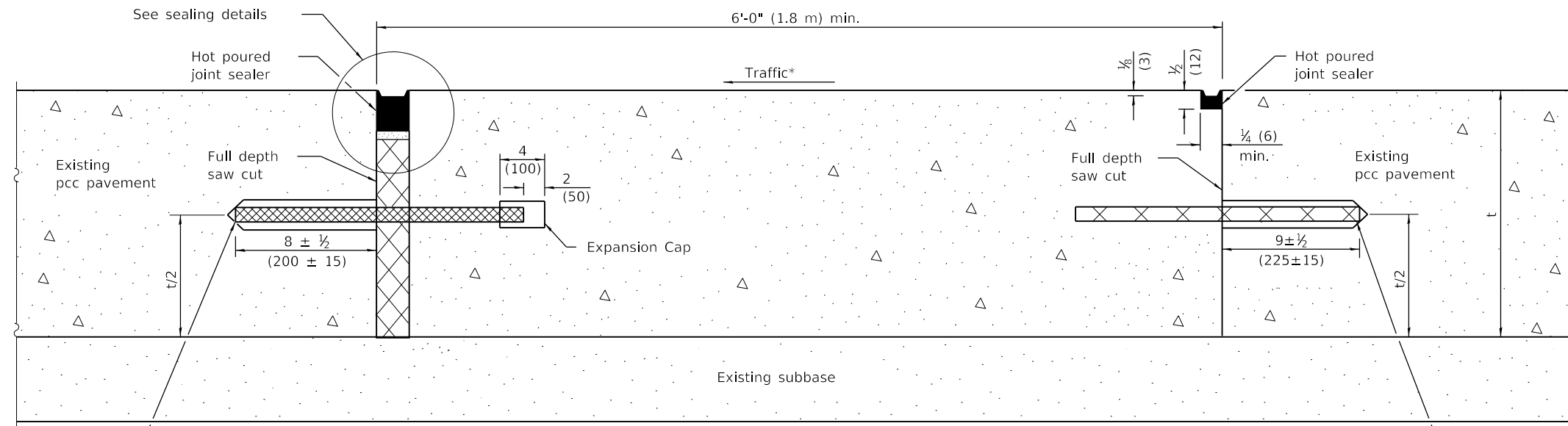

METHOD I
(Without Resurfacing)

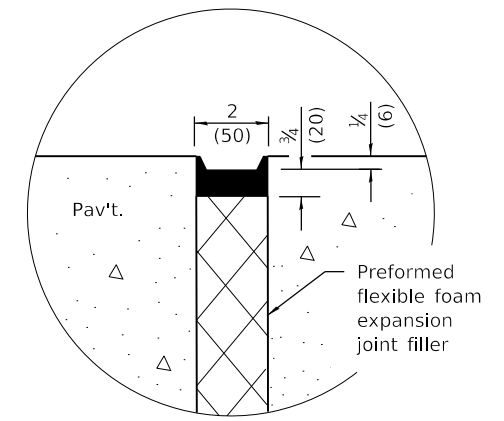

SEALING DETAIL

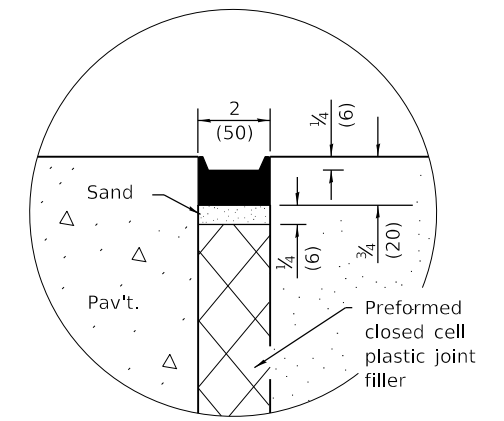

SEALING DETAIL

NOTE

* When re-establishing a transverse expansion joint on a two-lane, two-way road, reverse the orientation of the dowel bars with respect to traffic for one of the patches such that the joint will be continuous across both lanes.

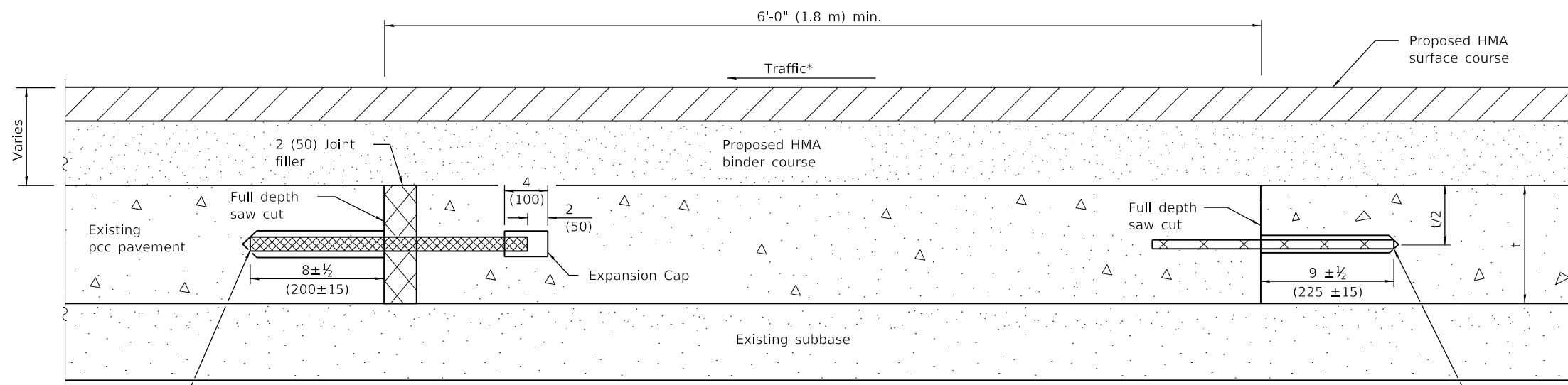

METHOD II
(With Resurfacing)

No. 10x18 (No. 32x450)
Tie bars anchored into existing pavement at 12 (300) cts.

Illinois Department of Transportation

PASSED January 1, 2019
Michael Bond
ENGINEER OF POLICY AND PROCEDURES

APPROVED January 1, 2019
John E. ...
ENGINEER OF DESIGN AND ENVIRONMENT

ISSUED 1-1-97

CLASS B PATCHES

(Sheet 2 of 2)

STANDARD 442101-09

CLASS C

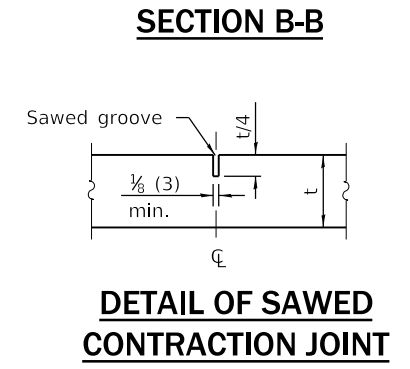
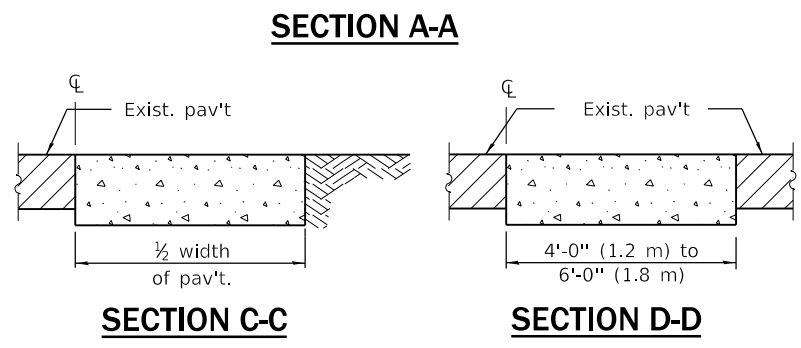
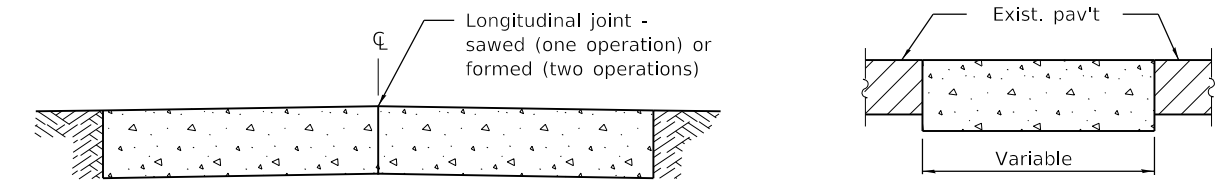
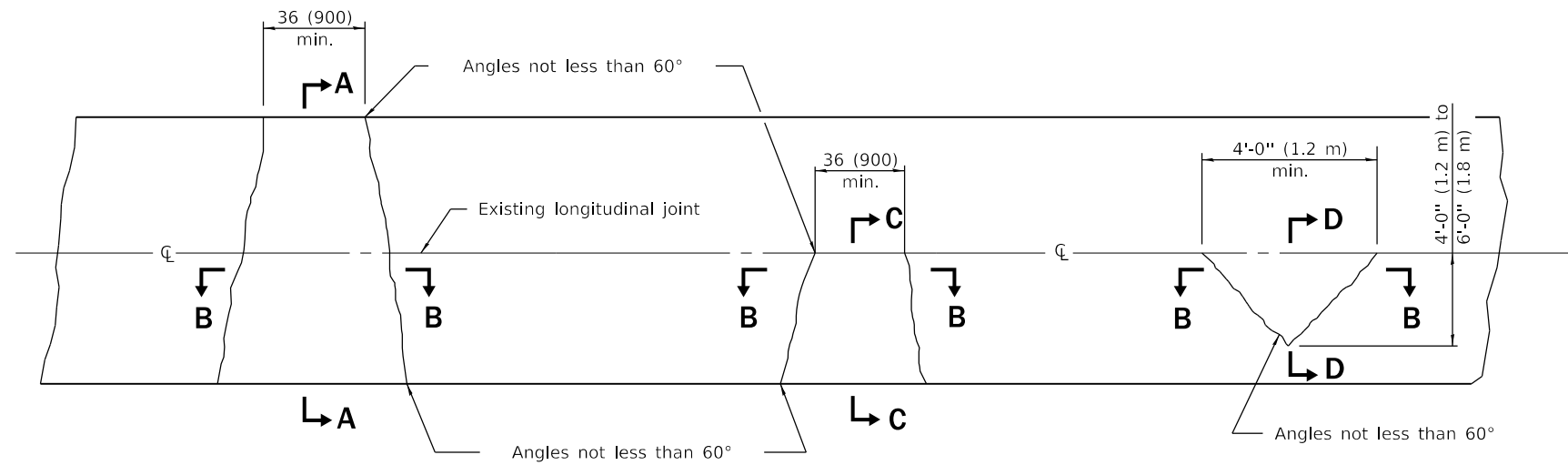

Note:
Longitudinal joints shall be as detailed on Standard 420001, except tie bars are not required for patches 20'-0" (6.0 m) or less in length.

CLASS D

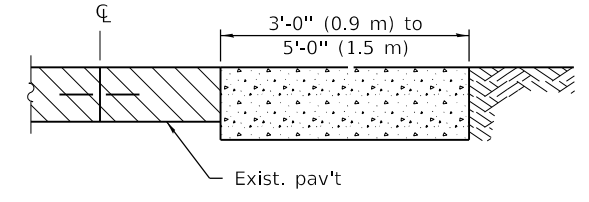
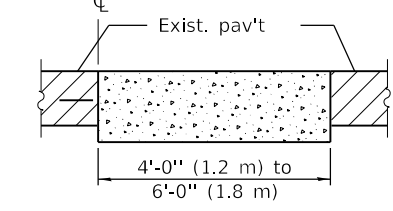
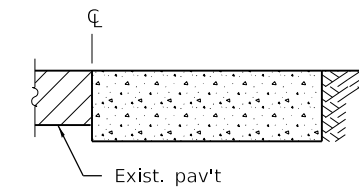
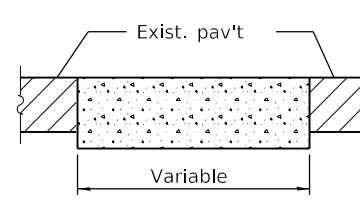
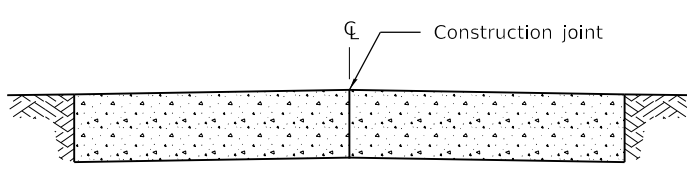
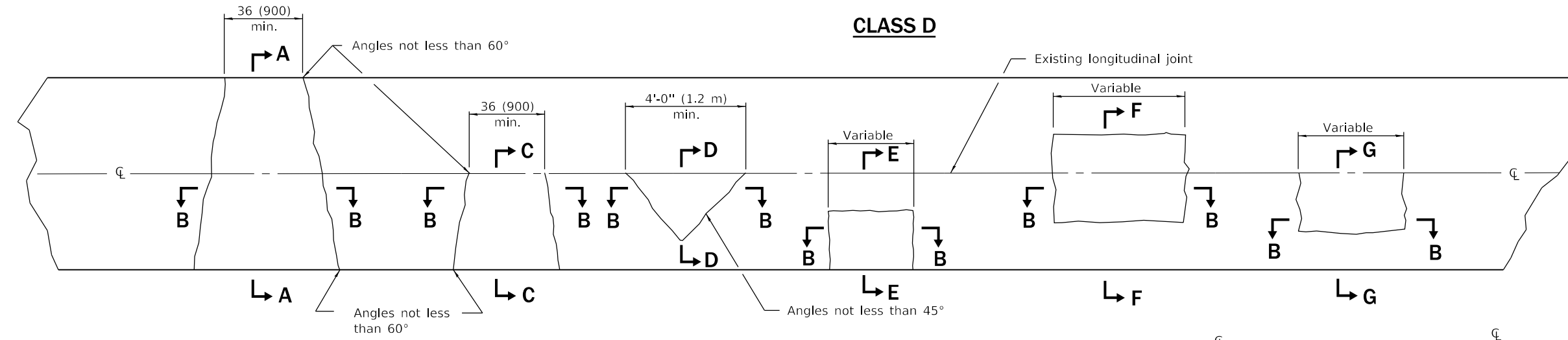

SECTION A-A
(Built in two operations)

SECTION B-B

SECTION C-C

SECTION D-D

SECTION E-E

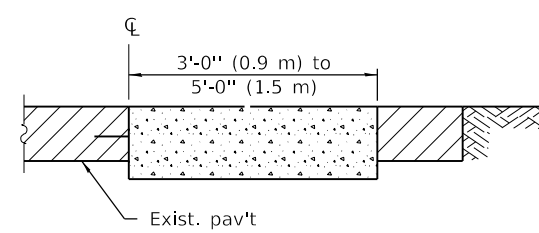
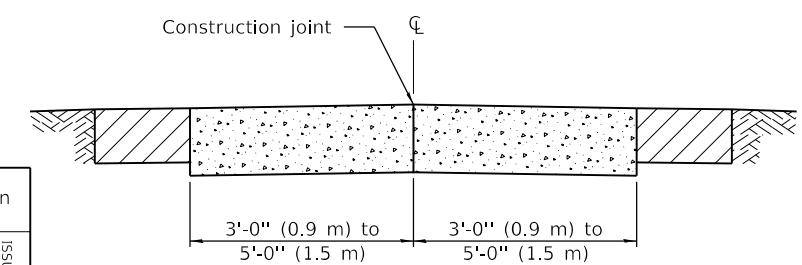

SECTION F-F
(Built in two operations)

SECTION G-G

GENERAL NOTES

Existing tie bars shall be either cut or removed. Marginal bars shall be cut.

All dimensions are in inches (millimeters) unless otherwise shown.

DATE	REVISIONS
1-1-08	Switched units to English (metric).
1-1-07	Revised Note for Class C patches.

CLASS C and D PATCHES

STANDARD 442201-03

Illinois Department of Transportation

PASSED January 1, 2008
Scott Smith
 ENGINEER OF POLICY AND PROCEDURES

APPROVED January 1, 2008
Lee E. Han
 ENGINEER OF DESIGN AND ENVIRONMENT

ISSUED 1-1-97

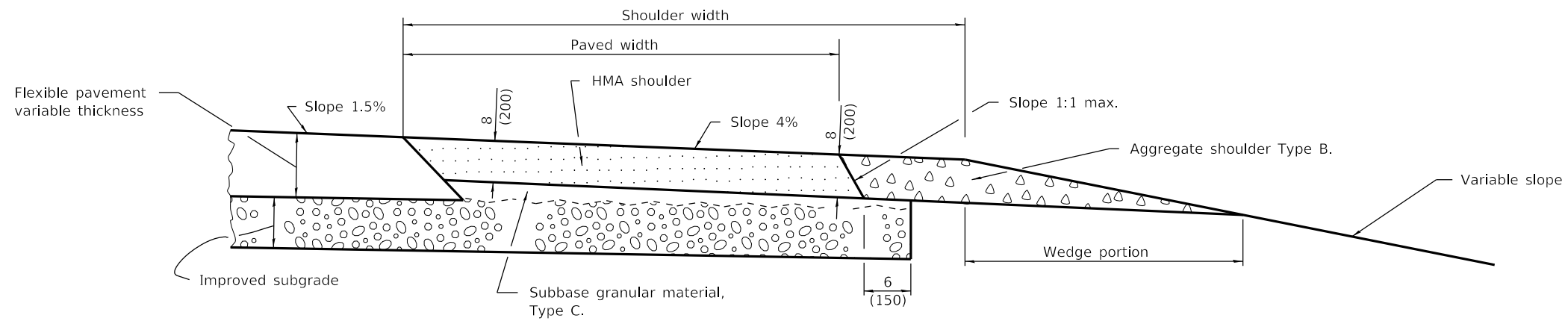

SHOULDER FOR TANGENT PAVEMENT

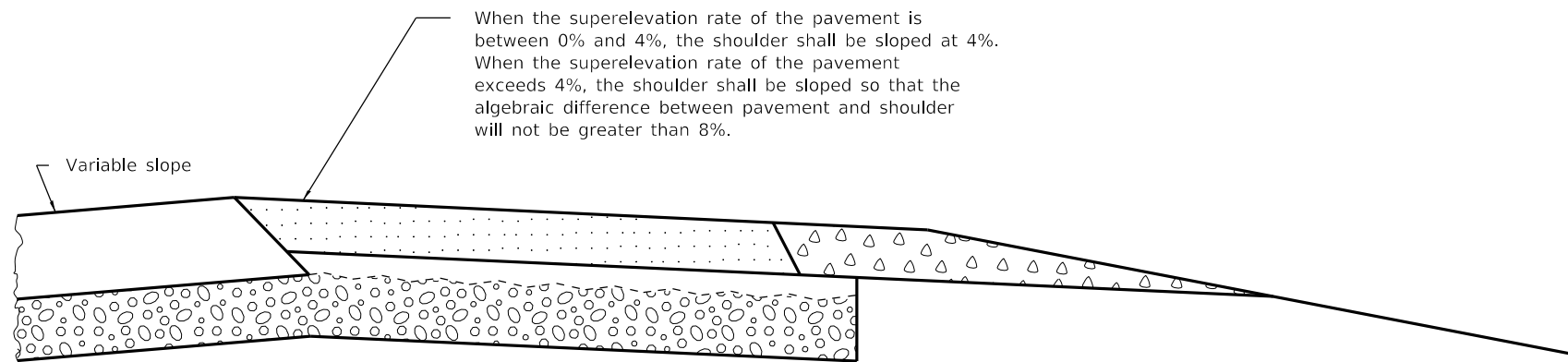

**SHOULDER FOR SUPERELEVATED PAVEMENT
(OUTSIDE OF CURVE)**

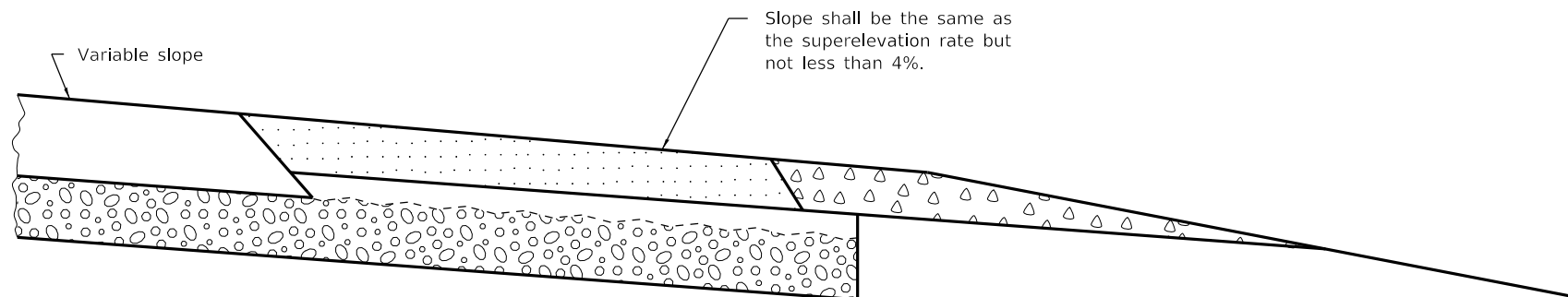

**SHOULDER FOR SUPERELEVATED PAVEMENT
(INSIDE OF CURVE)**

GENERAL NOTES

Except as noted or shown the dimensions and notes specified for the shoulder of tangent pavement are typical for the shoulders of superelevated pavement.

All dimensions are in inches (millimeters) unless otherwise shown.

Illinois Department of Transportation

PASSED January 1, 2008
[Signature]
 ENGINEER OF POLICY AND PROCEDURES

APPROVED January 1, 2008
[Signature]
 ENGINEER OF DESIGN AND ENVIRONMENT

ISSUED 1-1-97

DATE	REVISIONS
1-1-08	Switched units to English (metric).
1-1-07	Switched to Hot-Mix Asphalt (HMA) terminology.

HMA SHOULDER ADJACENT TO FLEXIBLE PAVEMENT

STANDARD 482001-02

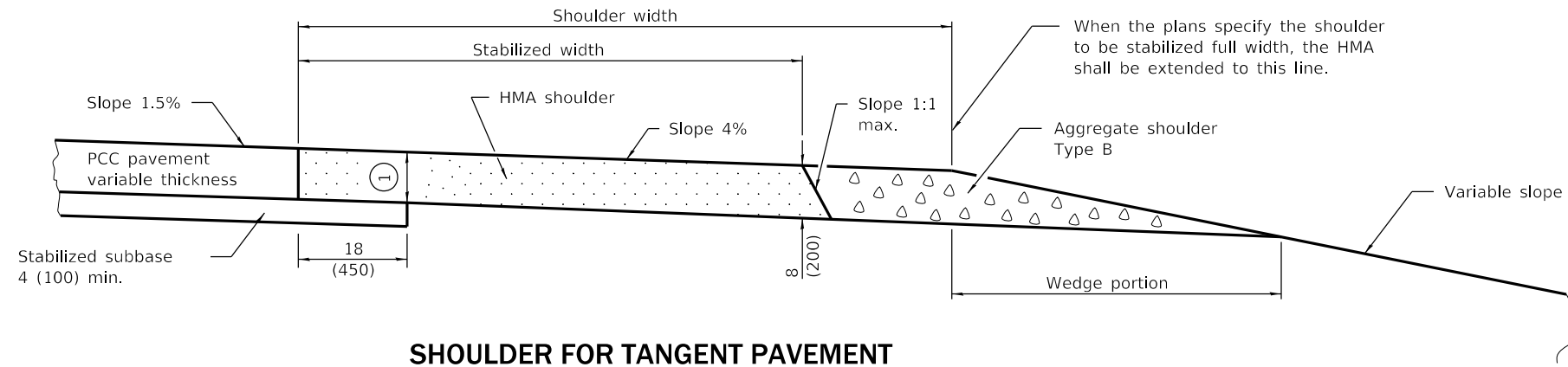

SHOULDER FOR TANGENT PAVEMENT

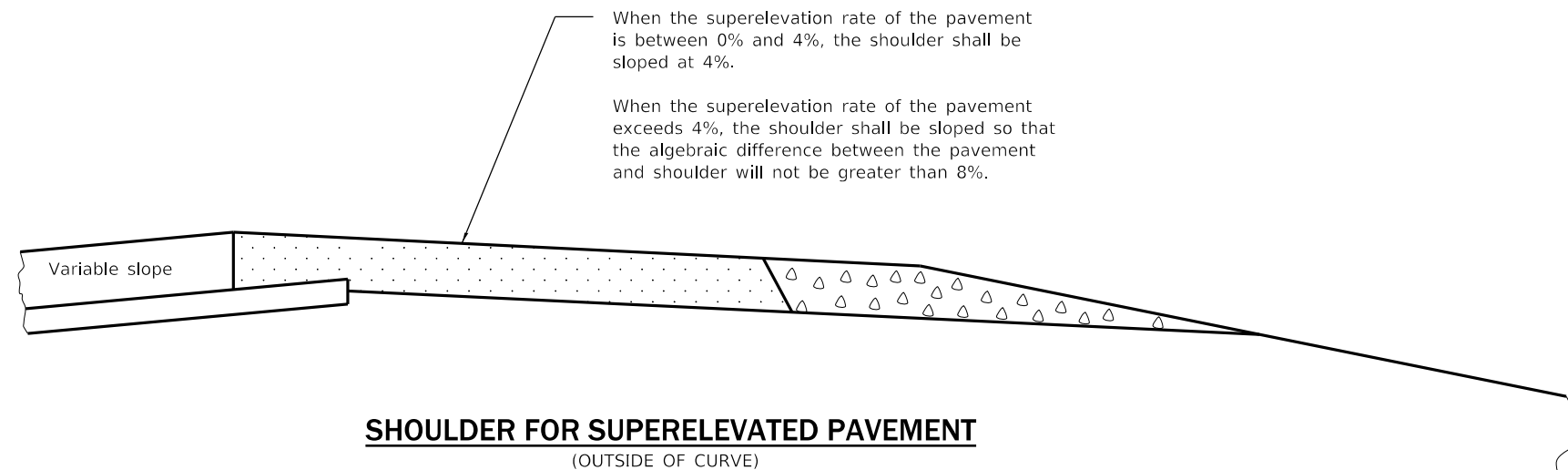

**SHOULDER FOR SUPERELEVATED PAVEMENT
(OUTSIDE OF CURVE)**

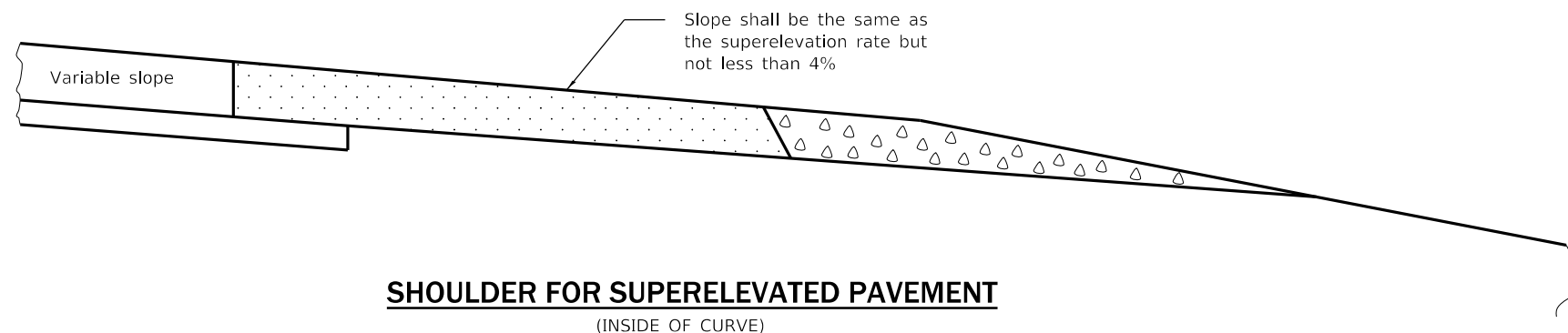

**SHOULDER FOR SUPERELEVATED PAVEMENT
(INSIDE OF CURVE)**

① (Applies only when subbase extension is to remain in place.) This thickness will vary with the thickness of pavement, extended length of subbase, and the slope of pavement. When this thickness is less than 8 (200), the stabilized shoulder shall be stepped down at this line to provide a 8 (200) minimum thickness.

GENERAL NOTES

Except as noted or shown the dimensions and notes specified for the shoulder of tangent pavement are typical for the shoulders of superelevated pavement.

All slope ratios are expressed as units of vertical displacement to units of horizontal displacement (V:H).

All dimensions are in inches (millimeters) unless otherwise shown.

Illinois Department of Transportation

PASSED January 1, 2008
[Signature]
 ENGINEER OF POLICY AND PROCEDURES

APPROVED January 1, 2008
[Signature]
 ENGINEER OF DESIGN AND ENVIRONMENT

ISSUED 1-1-97

DATE	REVISIONS
1-1-08	Switched units to English (metric).
1-1-07	Switched to Hot-Mix Asphalt (HMA) terminology.

HMA SHOULDER ADJACENT TO RIGID PAVEMENT

STANDARD 482006-03

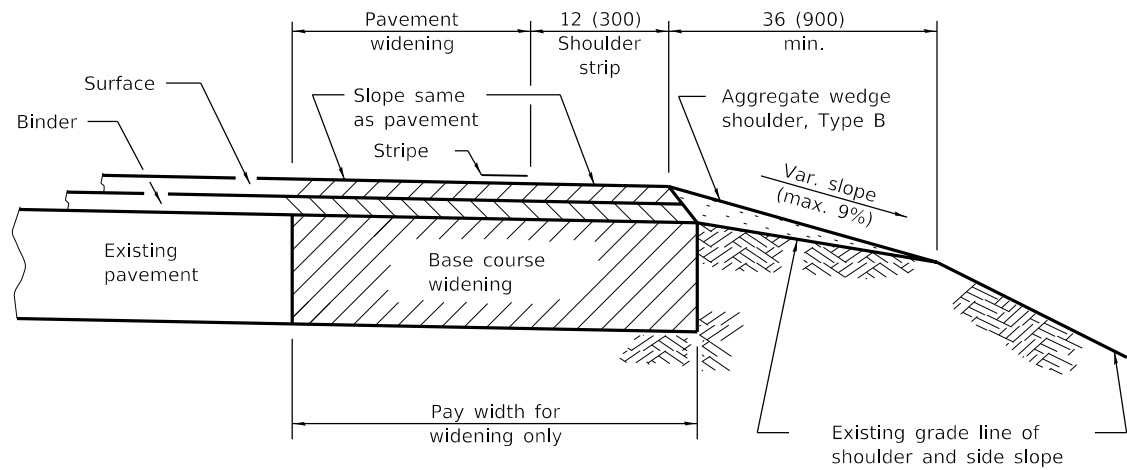

**HMA SHOULDER STRIP AND
AGGREGATE WEDGE WITH WIDENING**
(Cross-section A)

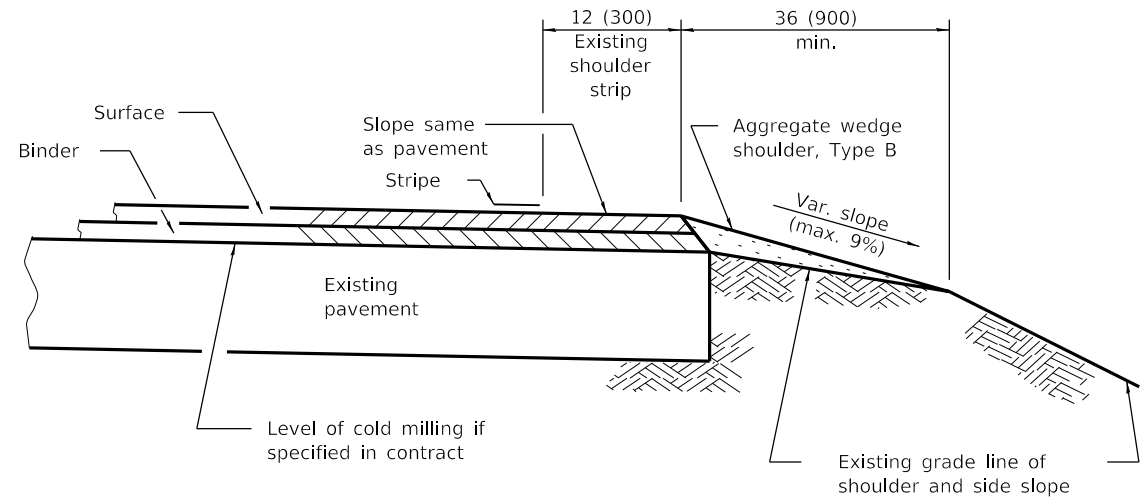

**COLD MILLING AND/OR RESURFACING OF
EXISTING PAVEMENT WITH SHOULDER STRIPS**
(Cross-section C)

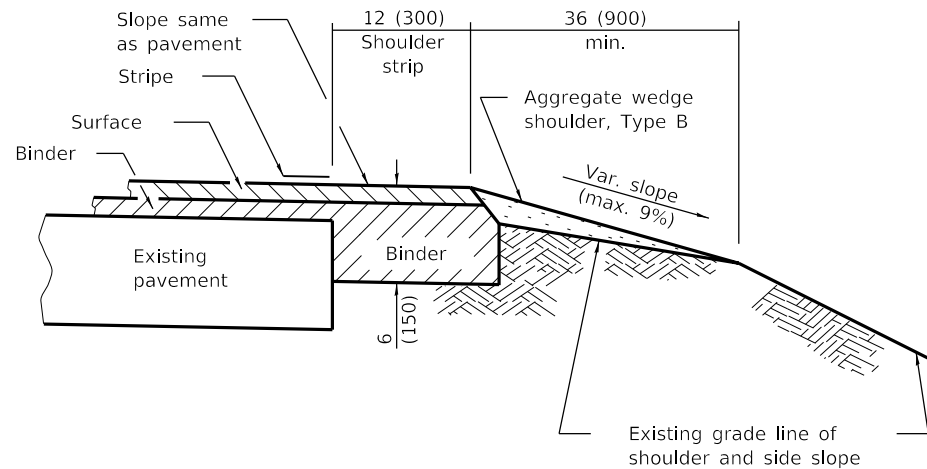

**HMA SHOULDER STRIP AND
AGGREGATE WEDGE WITH RESURFACING**
(Cross-section B)

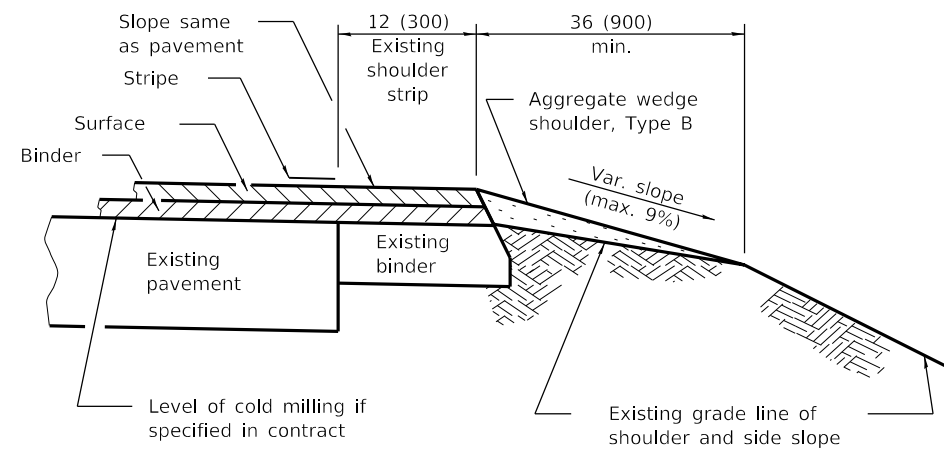

**COLD MILLING AND/OR RESURFACING OF
EXISTING PAVEMENT WITH SHOULDER STRIPS**
(Cross-section D)

All dimensions are in inches (millimeters)
unless otherwise shown.

Illinois Department of Transportation

PASSED January 1, 2008
[Signature]
ENGINEER OF POLICY AND PROCEDURES

APPROVED January 1, 2008
[Signature]
ENGINEER OF DESIGN AND ENVIRONMENT

ISSUED 1-1-97

DATE	REVISIONS
1-1-08	Switched units to English (metric).
1-1-07	Switched to Hot-Mix Asphalt (HMA) terminology.

**HMA SHLD. STRIPS/SHLDS. WITH
RESURFACING OR WIDENING
AND RESURFACING PROJECTS**

(Sheet 1 of 2)

STANDARD 482011-03

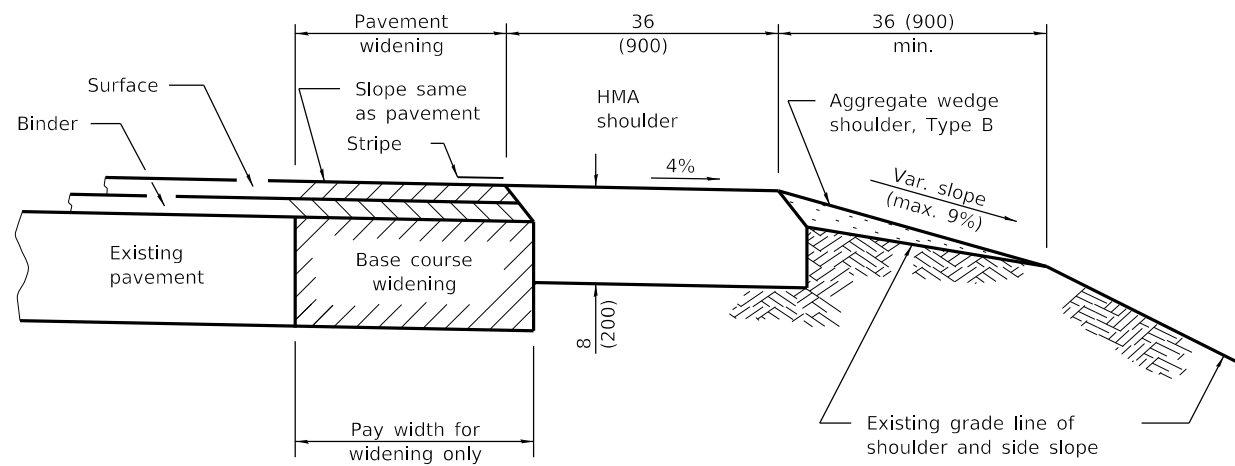

HMA SHOULDER AND AGGREGATE WEDGE WITH WIDENING

(Cross-section E)

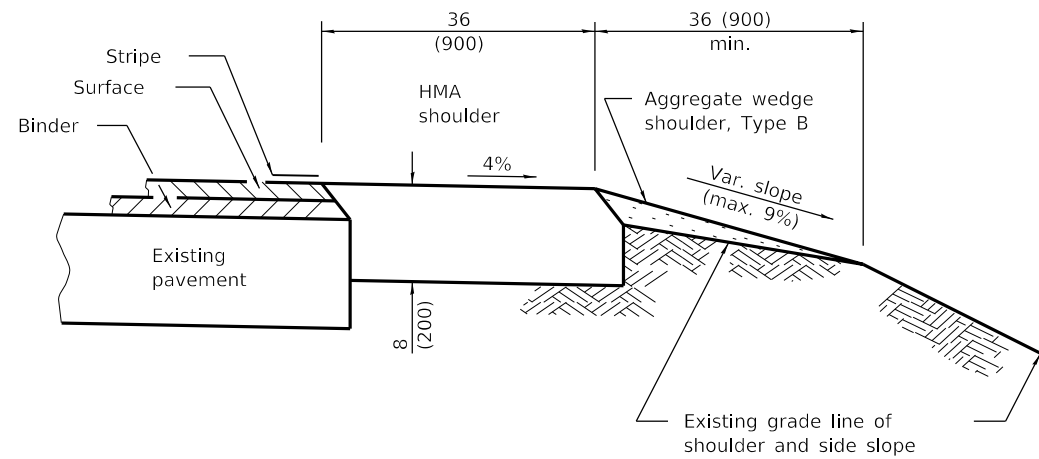

HMA SHOULDER AND AGGREGATE WEDGE WITH RESURFACING

(Cross-section G)

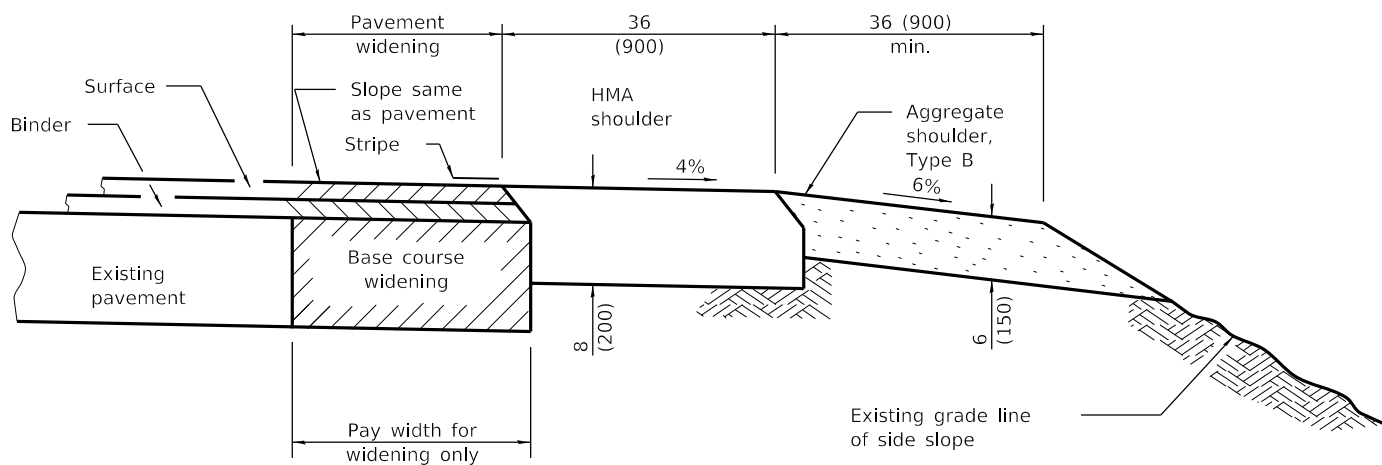

HMA AND AGGREGATE SHOULDERS WITH WIDENING

(Cross-section F)

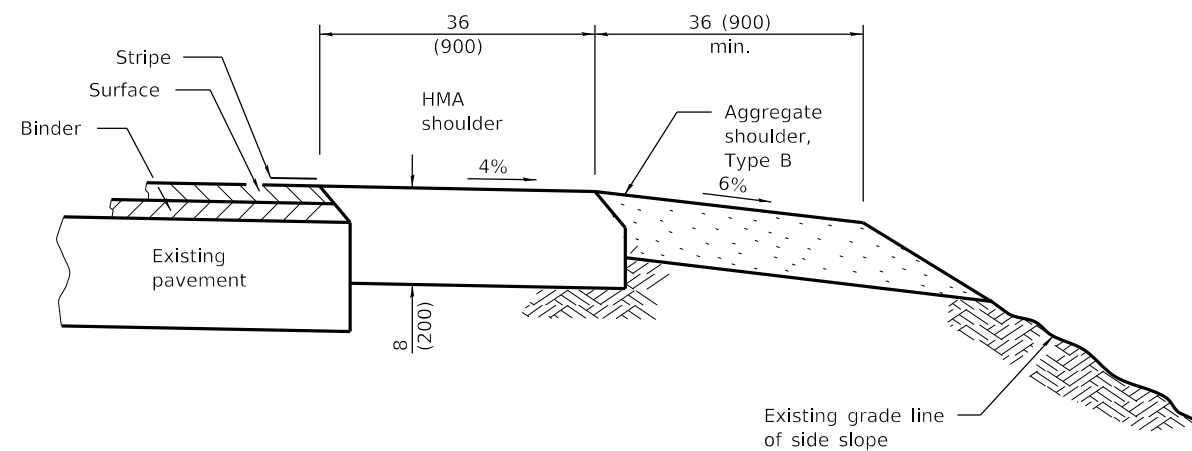

HMA AND AGGREGATE SHOULDERS WITH RESURFACING

(Cross-section H)

Illinois Department of Transportation

PASSED January 1, 2008
[Signature]
 ENGINEER OF POLICY AND PROCEDURES

APPROVED January 1, 2008
[Signature]
 ENGINEER OF DESIGN AND ENVIRONMENT

ISSUED 1-1-97

HMA SHLD. STRIPS/SHLDS. WITH RESURFACING OR WIDENING AND RESURFACING PROJECTS

(Sheet 2 of 2)

STANDARD 482011-03

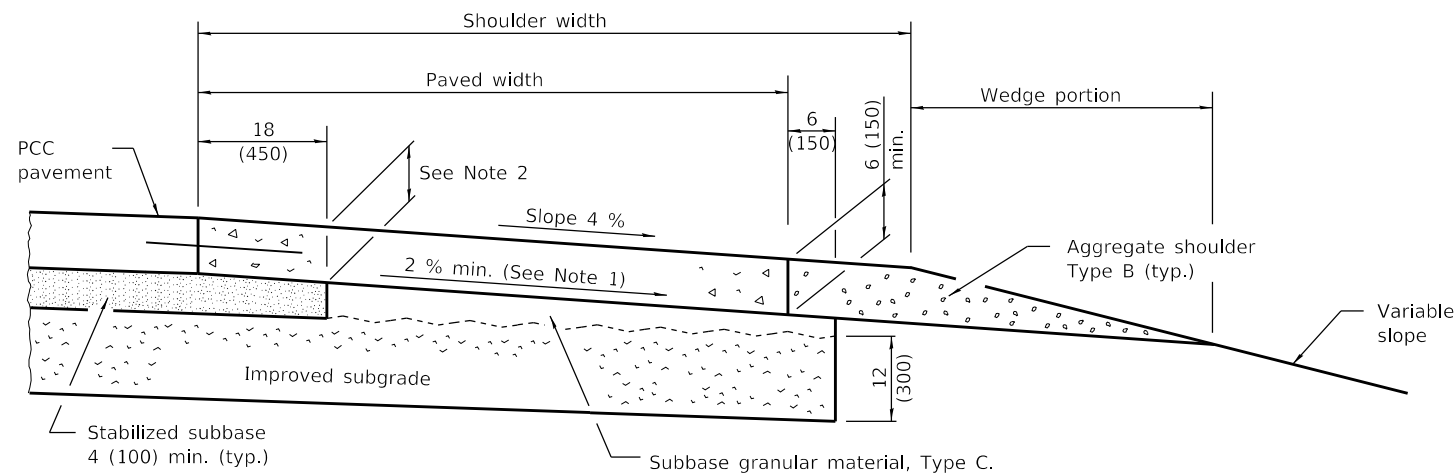

SHOULDER FOR TANGENT PAVEMENT

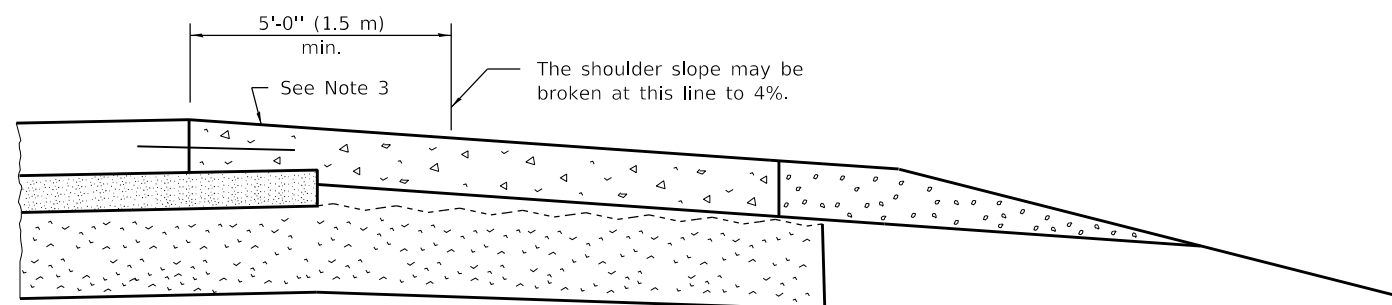

SHOULDER FOR SUPERELEVATED PAVEMENT

(Outside of curve)

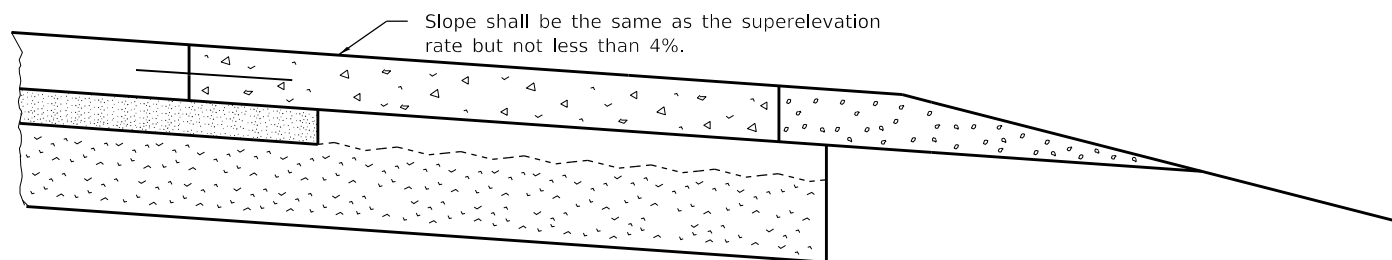

SHOULDER FOR SUPERELEVATED PAVEMENT

(Inside of curve)

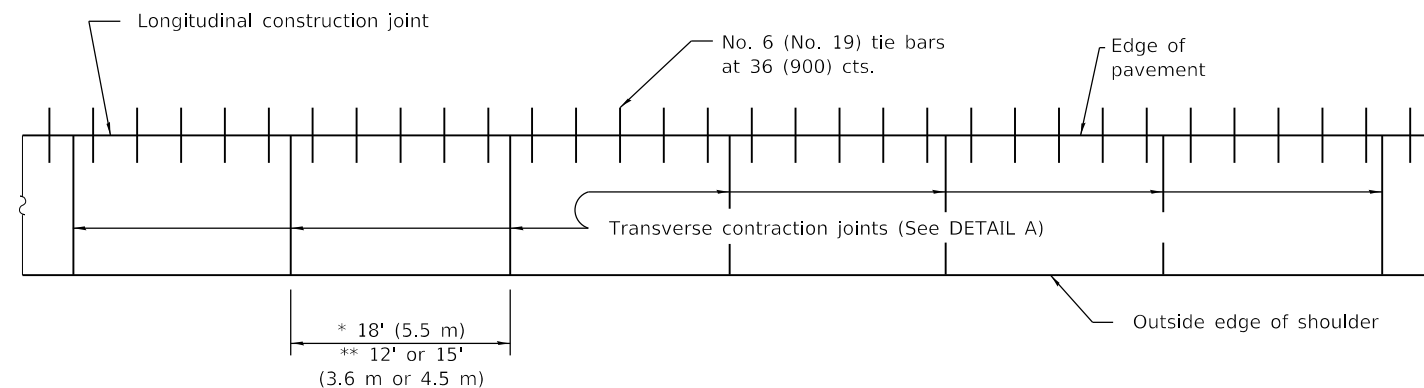

* spacing adjacent to CRC pavement
** spacing adjacent to jointed pavement to match matchline

PLAN

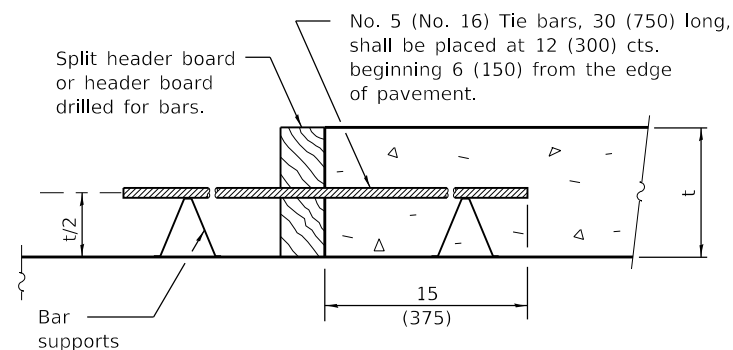

TRANSVERSE CONSTRUCTION JOINT

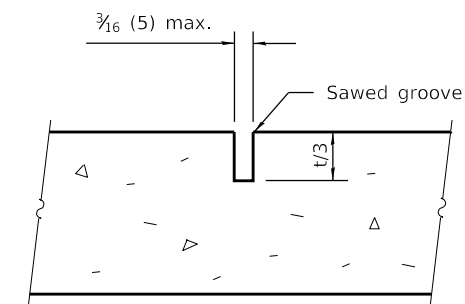

DETAIL A

TRANSVERSE CONTRACTION JOINT

NOTES

- Note 1: Does not apply when sub-surface drains are installed.
- Note 2: When the subbase is not removed, this thickness will vary with the thickness of pavement, extended length of subbase, and the slope of pavement. When this thickness is less than 6 (150), the paved shoulder shall be stepped down at this line to provide a 6 (150) minimum thickness.
- Note 3: When the superlevation rate of the pavement is between 0% and 4%, the shoulder shall be sloped at 4%. When the superlevation rate of the pavement exceeds 4%, the shoulder shall be sloped so that the algebraic difference between the pavement and shoulder slopes will not be greater than 8%.

GENERAL NOTES

Except as noted or shown, the dimensions and notes specified for the shoulder of the tangent pavement are typical for the shoulders of superelevated pavement.

Transverse expansion joints shall be as detailed on Standard 420001 except dowel bars will not be required.

See Standard 420001 for details not shown.

All dimensions are in inches (millimeters) unless otherwise shown.

Illinois Department of Transportation

PASSED January 1, 2022
Michael Brand
ENGINEER OF POLICY AND PROCEDURES

APPROVED January 1, 2022
John C. ...
ENGINEER OF DESIGN AND ENVIRONMENT

ISSUED 1-1-97

DATE	REVISIONS
1-1-22	Revised header board callout, Detail A and spacing of transverse contraction joints.
1-1-18	Modified PLAN view. Changed tie bar spacing to 36 (900).

PCC SHOULDER

STANDARD 483001-06

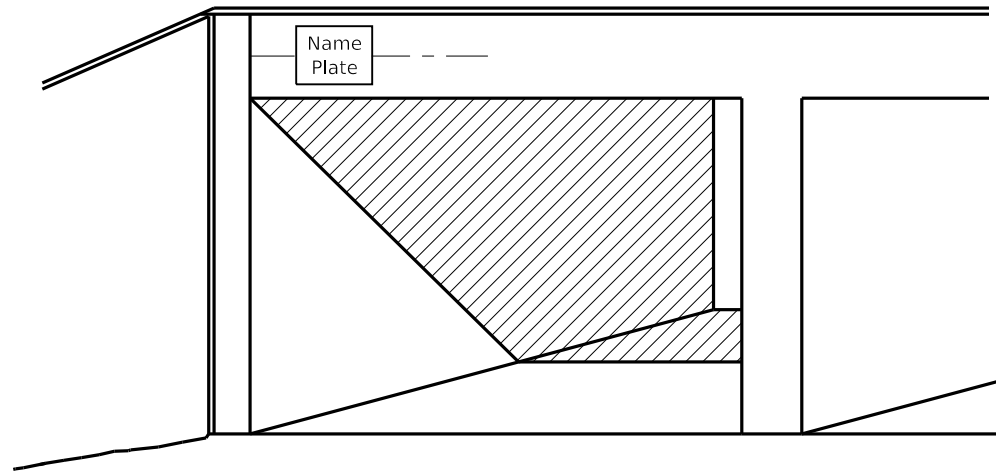

MULTI-SPAN CULVERTS

(Unless otherwise noted on the plans, name plates are not required for structures less than 20' (6.1 m) in length)

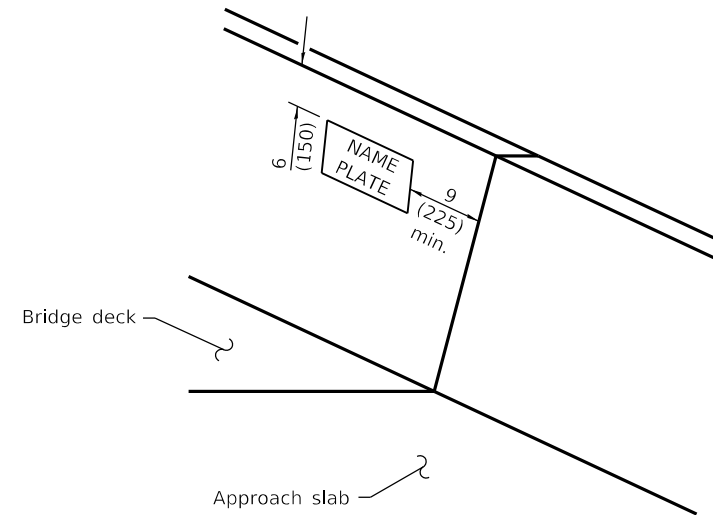

PARAPET
(Typical)

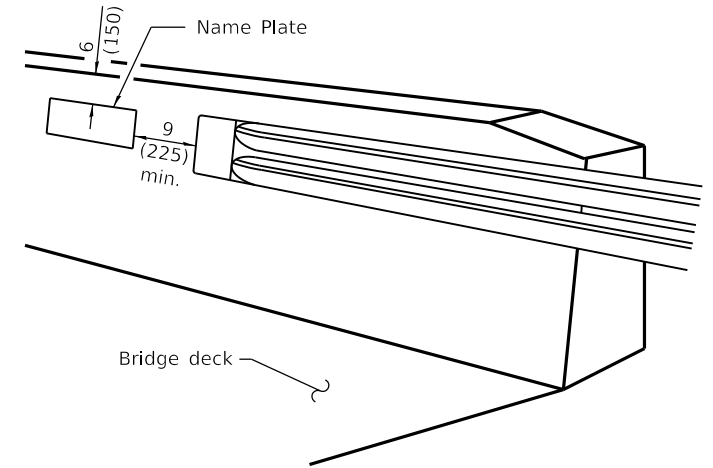

PARAPET
(Terminated at end of bridge)

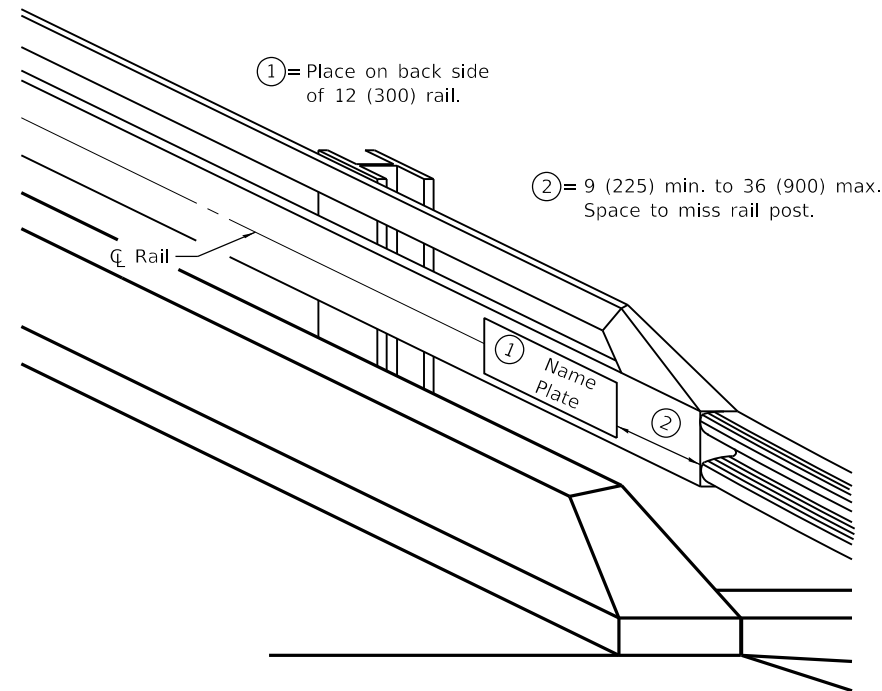

STEEL RAILS

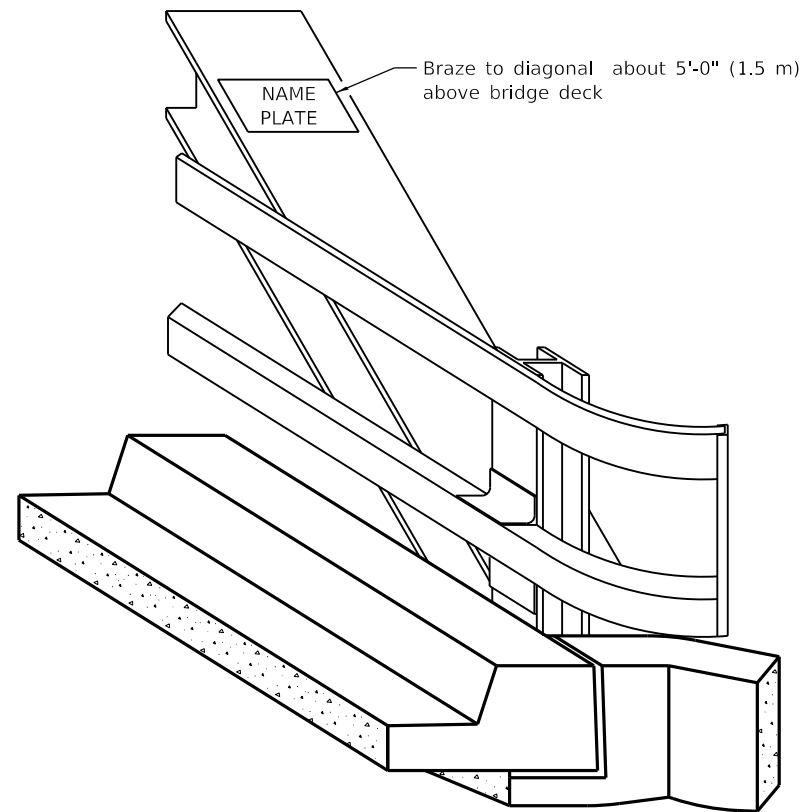

TRUSSES

For column type piers, ϕ of column nearest approaching traffic. For solid piers, 3'-0" \pm from end of pier closest to approaching traffic.

4'-0" \pm above crown of roadway elevation.

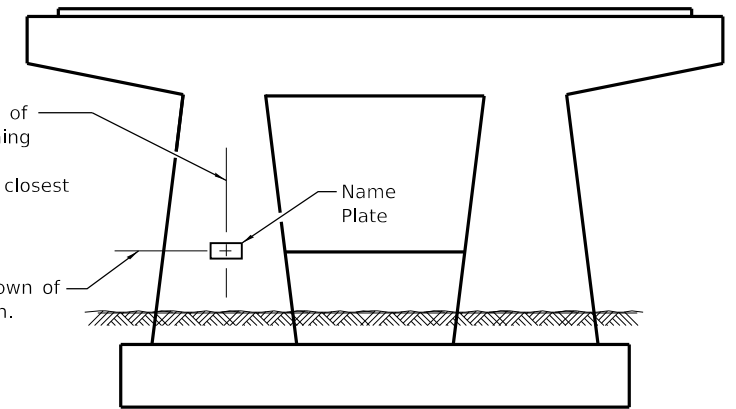

PIERS ON FAI ROUTES

GENERAL NOTES

On one-way traffic structures, place name plate on right side of approach end. On two-way traffic structures, place name plate on right side of approach end while looking in the direction of increasing stationing.

All dimensions are in inches (millimeters) unless otherwise shown.

Illinois Department of Transportation

APPROVED January 1, 2020
[Signature]
 ENGINEER OF BRIDGES AND STRUCTURES

APPROVED January 1, 2020
[Signature]
 ENGINEER OF DESIGN AND ENVIRONMENT

ISSUED 1-1-97

DATE	REVISIONS
1-1-20	Revised F-shape to constant slope parapet.
1-1-09	Switched units to English (metric). Added pier detail.
1-1-02	Removed Placing: note on sht. 2. Added braze note on sht. 1.

NAME PLATE FOR BRIDGES

(Sheet 1 of 2)

STANDARD 515001-04

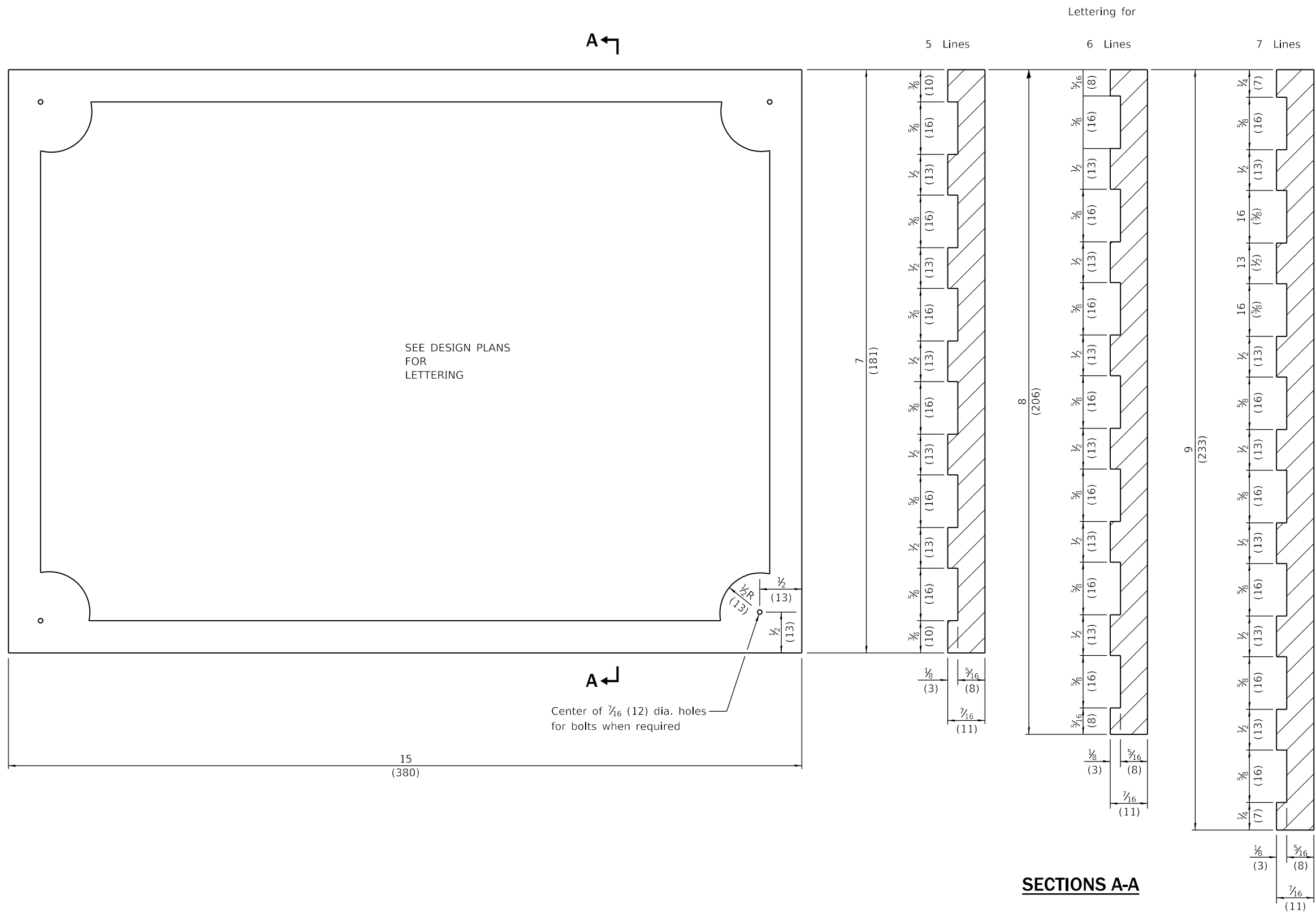

NOTE
 Border and lettering:
 Raised $\frac{1}{8}$ (3), square cut and not tapered.

Illinois Department of Transportation

APPROVED January 1, 2020

ENGINEER OF BRIDGES AND STRUCTURES

APPROVED January 1, 2020

ENGINEER OF DESIGN AND ENVIRONMENT

ISSUED 1-1-97

**NAME PLATE
 FOR BRIDGES**

(Sheet 2 of 2)

STANDARD 515001-04

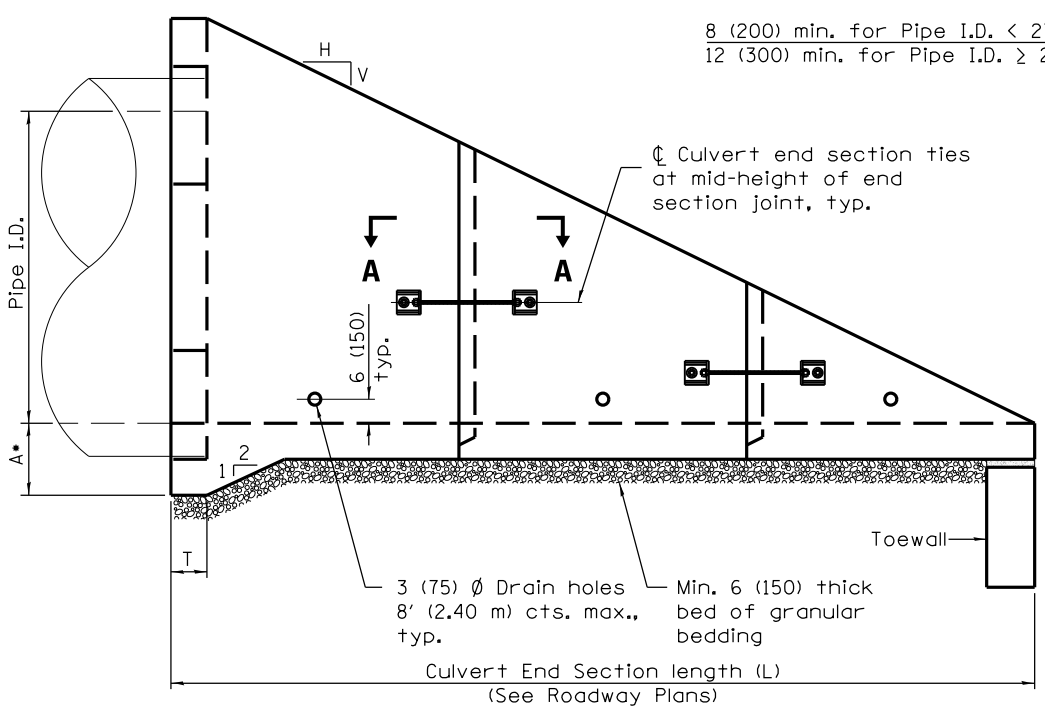

ELEVATION

• This dimension shall be increased by 1/2 (38) for CIP field construction. See General Notes.

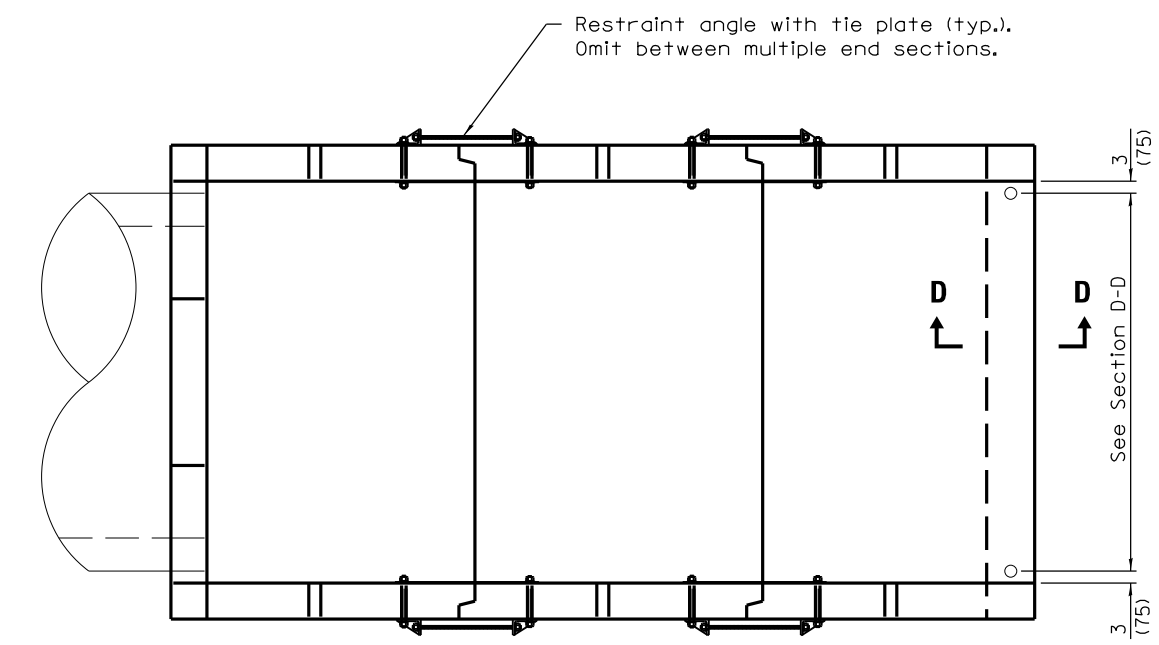

PLAN

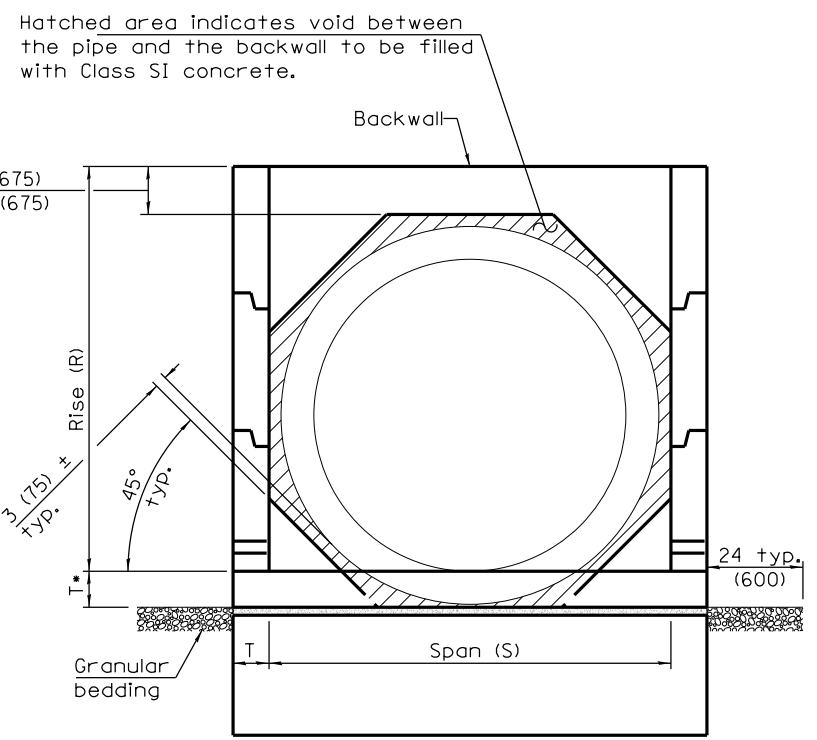

END VIEW

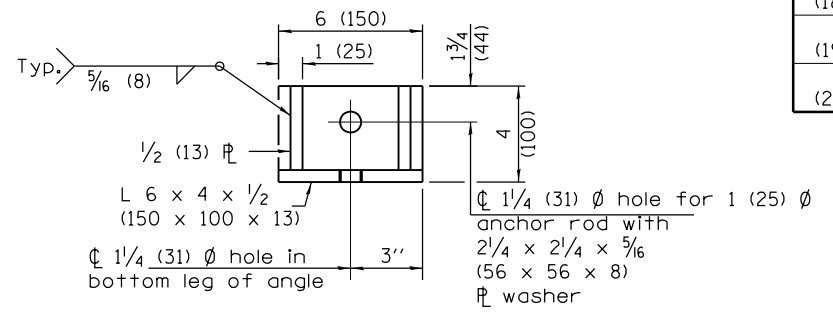

RESTRAINT ANGLE DETAIL

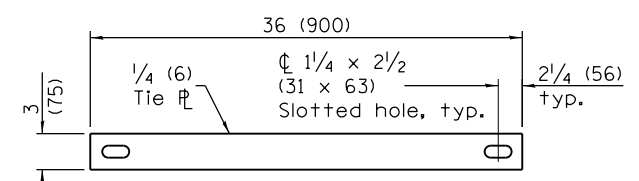

TIE PLATE DETAIL

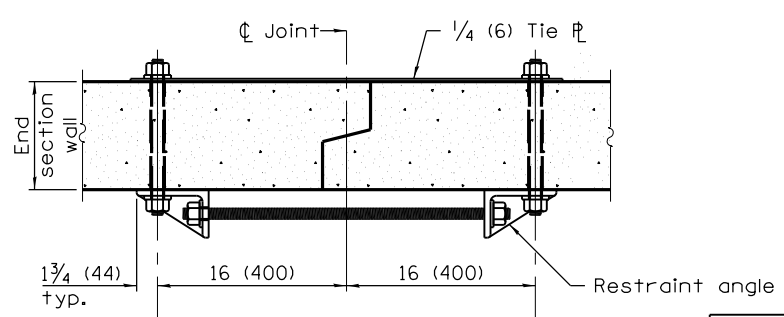

∅ 1 (25) ∅ Anchor rods with 2 1/4 x 2 1/4 x 5/16 (56 x 56 x 8) ∅ washers installed in 1/8 (28) ∅ formed holes in end section walls

SECTION A-A
(Showing end section tie details)

PIPE CULVERT END SECTION DIMENSIONS

Pipe I.D.	A	R	S	T	L			
					Slope of End Section			
					1:2	1:3	1:4	1:6
15 (375)	14 (350)	29 (737)	28 (711)	8 (200)	5'-6" (1.68 m)	7'-11" (2.42 m)	10'-4" (3.16 m)	15'-2" (4.63 m)
18 (450)	15 (375)	33 (838)	32 (813)	8 (200)	6'-2" (1.88 m)	8'-11" (2.72 m)	11'-8" (3.56 m)	17'-2" (5.24 m)
21 (525)	15 (375)	36 (914)	34 (864)	8 (200)	6'-8" (2.03 m)	9'-8" (2.95 m)	12'-8" (3.86 m)	18'-8" (5.69 m)
24 (600)	15 (375)	39 (990)	38 (970)	8 (200)	7'-2" (2.19 m)	10'-5" (3.18 m)	13'-8" (4.17 m)	20'-2" (6.15 m)
27 (675)	15 (375)	3'-10" (1.17 m)	3'-6" (1.07 m)	8 (200)	8'-4" (2.54 m)	12'-2" (3.71 m)	16'-0" (4.88 m)	23'-8" (7.21 m)
30 (750)	16 (400)	4'-2" (1.27 m)	3'-10" (1.17 m)	8 (200)	9'-0" (2.75 m)	13'-2" (4.02 m)	17'-4" (5.29 m)	25'-8" (7.83 m)
33 (825)	16 (400)	4'-5" (1.35 m)	4'-0" (1.22 m)	8 (200)	9'-6" (2.90 m)	13'-11" (4.25 m)	18'-4" (5.60 m)	27'-2" (8.29 m)
36 (900)	16 (400)	4'-8" (1.42 m)	4'-4" (1.32 m)	8 (200)	10'-0" (3.05 m)	14'-8" (4.47 m)	19'-4" (5.90 m)	28'-8" (8.74 m)
42 (1050)	17 (425)	5'-3" (1.60 m)	5'-0" (1.52 m)	8 (200)	11'-2" (3.41 m)	16'-5" (5.01 m)	21'-8" (6.61 m)	32'-2" (9.81 m)
48 (1200)	17 (425)	5'-9" (1.75 m)	5'-6" (1.68 m)	8 (200)	12'-2" (3.71 m)	17'-11" (5.46 m)	23'-8" (7.22 m)	35'-2" (10.73 m)
54 (1350)	18 (450)	6'-4" (1.93 m)	6'-2" (1.88 m)	8 (200)	13'-4" (4.07 m)	19'-8" (6.00 m)	26'-0" (7.93 m)	38'-8" (11.79 m)
60 (1500)	18 (450)	6'-10" (2.08 m)	6'-8" (2.03 m)	8 (200)	14'-4" (4.37 m)	21'-2" (6.46 m)	28'-0" (8.54 m)	41'-8" (12.71 m)
66 (1650)	19 (475)	7'-5" (2.26 m)	7'-4" (2.24 m)	8 (200)	15'-6" (4.73 m)	22'-11" (6.99 m)	30'-4" (9.26 m)	45'-2" (13.78 m)
72 (1800)	19 (475)	7'-11" (2.41 m)	7'-10" (2.39 m)	8 (200)	16'-6" (5.03 m)	24'-5" (7.45 m)	32'-4" (9.87 m)	48'-2" (14.70 m)
78 (1950)	21 (525)	8'-6" (2.59 m)	8'-6" (2.59 m)	9 (230)	17'-9" (5.41 m)	26'-3" (8.01 m)	34'-9" (10.60 m)	51'-9" (15.78 m)
84 (2100)	21 (525)	9'-0" (2.74 m)	9'-0" (2.74 m)	9 (230)	18'-9" (5.72 m)	27'-9" (8.46 m)	36'-9" (11.21 m)	54'-9" (16.70 m)

GENERAL NOTES

This Standard is for use with single pipe culverts and multi-pipe culvert installations. For multi-pipe culvert installations, place the end sections side-by-side leaving a 3 (75) space between adjacent end section walls and fill the space(s) with Class SI concrete.

The number of segments shown in elevation is for example only. The length and number of precast sections required to construct the end section shall be determined by the Contractor.

See roadway plans for slope (V:H) and pipe inside diameter.

End section may be installed up to ± 15 degrees skewed with roadway.

2 1/4 x 2 1/4 x 5/16 (56 x 56 x 8) plate washers shall be provided under each nut required for the anchor rods. Holes in the walls for the culvert tie assembly may be drilled using core bits in lieu of formed holes.

See Standard 542311 for end sections having traversable pipe grate.

All slope ratios are expressed as units of vertical displacement to units of horizontal displacement (V:H).

All dimensions are in inches (millimeters) unless otherwise shown.

DATE	REVISIONS
4-15-16	Added general note for multiple end sections.
4-1-16	Added note to omit restraint angle and tie plate for mult. end sections.

**CONCRETE END SECTIONS FOR PIPE CULVERTS
15" (375 mm) THRU 84" (2100 mm) DIA.**

(Sheet 1 of 3)

STANDARD 542001-06

Illinois Department of Transportation

APPROVED April 15, 2016
ENGINEER OF BRIDGES AND STRUCTURES

APPROVED April 15, 2016
ENGINEER OF DESIGN AND ENVIRONMENT

ISSUED 1-1-97

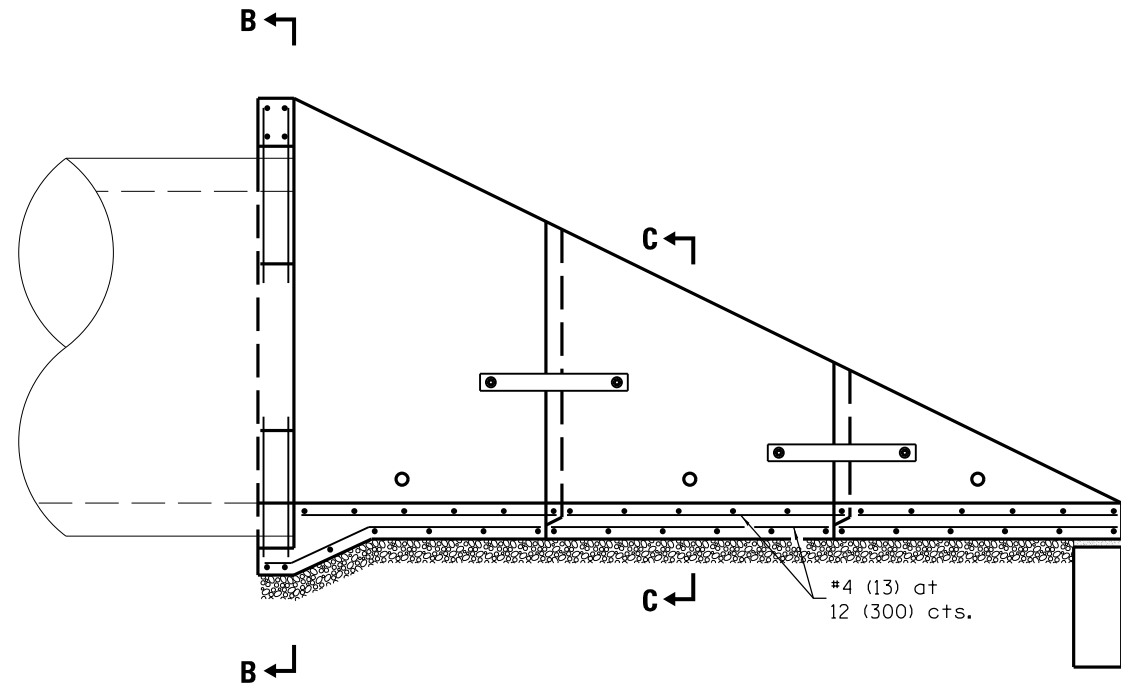

LONGITUDINAL SECTION

(Showing bottom slab and backwall reinforcement.)

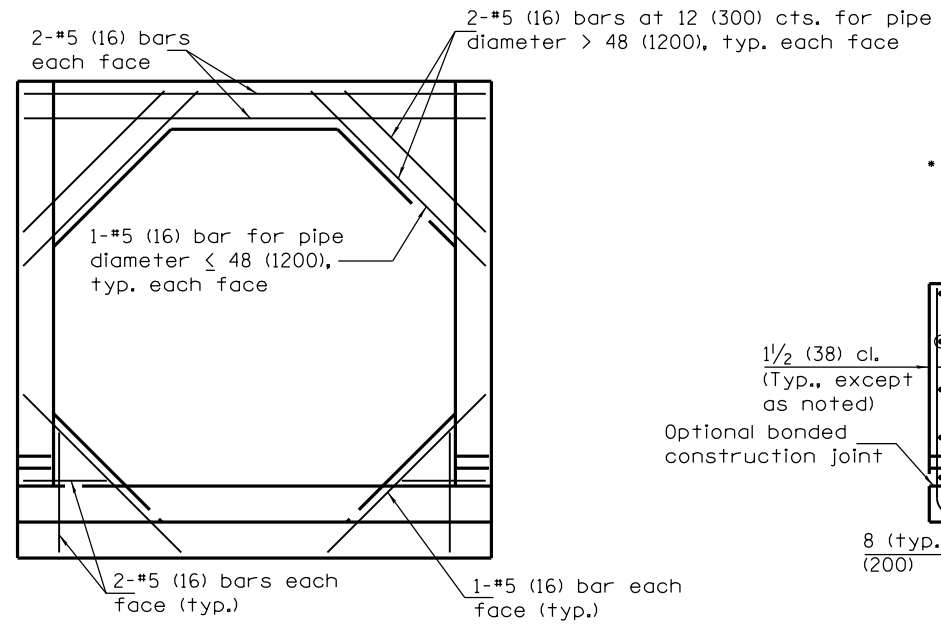

SECTION B-B

(Showing backwall reinforcement only.)
(Pipe omitted for clarity.)

LAP DIMENSION
 #4 (13) bar = 17 (425)
 #5 (16) bar = 21 (525)
 #6 (19) bar = 25 (625)

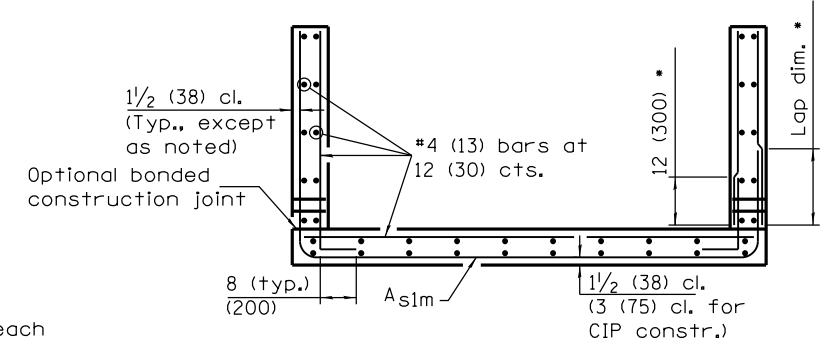

SECTION C-C

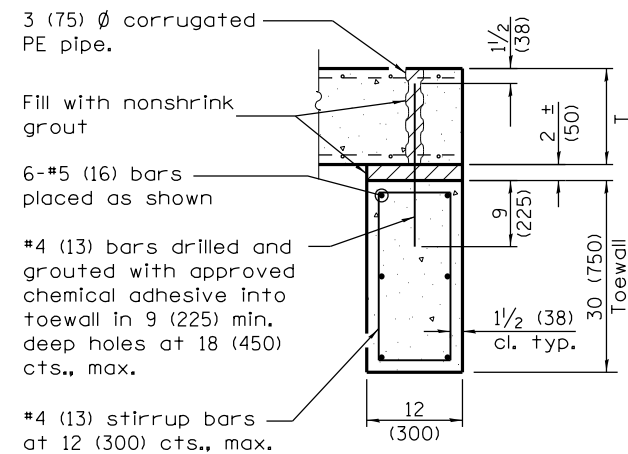

SECTION D-D

REINFORCEMENT SCHEDULE

Pipe I.D.	A _{slm}	
	Bar Size	Bar Spacing
15 (375)	4 (13)	12 (300)
18 (450)	4 (13)	12 (300)
21 (525)	4 (13)	12 (300)
24 (600)	4 (13)	12 (300)
27 (675)	4 (13)	12 (300)
30 (750)	4 (13)	12 (300)
33 (825)	4 (13)	12 (300)
36 (900)	4 (13)	12 (300)
42 (1050)	4 (13)	8 (200)
48 (1200)	4 (13)	8 (200)
54 (1350)	5 (16)	8 (200)
60 (1500)	5 (16)	8 (200)
66 (1650)	5 (16)	8 (200)
72 (1800)	6 (19)	8 (200)
78 (1950)	6 (19)	8 (200)
84 (2100)	6 (19)	8 (200)

Illinois Department of Transportation

APPROVED April 15, 2016
[Signature]
 ENGINEER OF BRIDGES AND STRUCTURES

APPROVED April 15, 2016
[Signature]
 ENGINEER OF DESIGN AND ENVIRONMENT

ISSUED 1-1-97

**CONCRETE END SECTIONS FOR PIPE CULVERTS
 15" (375 mm) THRU 84" (2100 mm) DIA.**

(Sheet 2 of 3)

STANDARD 542001-06

QUANTITIES

Pipe I.D.	Concrete yd ³ (m ³) ①				Reinforcement Without Lap lbs. (kg)				Reinforcement With Lap lbs (kg)			
	Slope of End Section				Slope of End Section				Slope of End Section			
	1:2	1:3	1:4	1:6	1:2	1:3	1:4	1:6	1:2	1:3	1:4	1:6
15 (375)	1.3 (1.0)	1.7 (1.3)	2.1 (1.6)	2.8 (2.1)	190 (85.2)	230 (104.1)	280 (123.3)	360 (159.2)	210 (94.9)	260 (117.6)	310 (140.3)	410 (182.9)
18 (450)	1.6 (1.2)	2.1 (1.6)	2.6 (2.0)	3.5 (2.7)	230 (104.3)	290 (131.1)	350 (158.0)	460 (207.3)	260 (114.8)	330 (146.0)	400 (177.3)	520 (234.0)
21 (525)	1.8 (1.4)	2.3 (1.8)	2.9 (2.2)	3.9 (3.0)	260 (114.5)	320 (143.3)	380 (172.2)	510 (229.9)	280 (126.5)	360 (159.7)	430 (193.0)	580 (259.5)
24 (600)	2.1 (1.6)	2.7 (2.1)	3.3 (2.5)	4.5 (3.4)	270 (121.9)	350 (155.8)	420 (189.3)	560 (251.5)	300 (133.9)	390 (172.8)	470 (211.6)	630 (282.6)
27 (675)	2.6 (2.0)	3.4 (2.6)	4.2 (3.2)	5.8 (4.4)	350 (155.5)	440 (198.5)	540 (244.4)	740 (336.3)	380 (169.6)	480 (217.8)	600 (269.6)	830 (373.2)
30 (750)	2.9 (2.2)	3.9 (3.0)	4.9 (3.7)	6.8 (5.2)	380 (169.6)	490 (219.2)	600 (271.9)	830 (374.0)	410 (184.5)	530 (240.0)	660 (299.2)	920 (413.9)
33 (825)	3.2 (2.4)	4.3 (3.3)	5.3 (4.1)	7.4 (5.7)	400 (179.7)	520 (234.9)	640 (290.3)	880 (397.6)	430 (195.2)	570 (257.2)	710 (319.0)	970 (438.9)
36 (900)	3.5 (2.7)	4.7 (3.6)	5.9 (4.5)	8.3 (6.3)	440 (197.8)	580 (262.4)	720 (323.8)	990 (449.4)	480 (214.2)	630 (286.1)	780 (354.0)	1090 (493.7)
42 (1050)	4.3 (3.3)	5.8 (4.4)	7.3 (5.6)	10.3 (7.9)	570 (256.4)	770 (346.4)	950 (429.0)	1330 (601.3)	620 (279.4)	840 (380.0)	1040 (471.6)	1470 (663.7)
48 (1200)	5.0 (3.8)	6.8 (5.2)	8.6 (6.6)	12.2 (9.3)	670 (301.1)	910 (409.9)	1140 (514.8)	1610 (728.2)	720 (325.6)	990 (445.8)	1240 (561.2)	1760 (796.8)
54 (1350)	6.0 (4.6)	8.2 (6.3)	10.3 (7.9)	14.7 (11.2)	890 (403.6)	1200 (544.5)	1530 (692.0)	2170 (985.0)	990 (448.6)	1340 (608.1)	1710 (775.8)	2440 (1108.2)
60 (1500)	6.8 (5.2)	9.3 (7.1)	11.8 (9.0)	16.8 (12.8)	1020 (461.5)	1400 (635.3)	1780 (806.8)	2530 (1149.8)	1120 (508.8)	1550 (704.5)	1980 (896.8)	2820 (1281.5)
66 (1650)	7.9 (6.0)	10.9 (8.3)	13.8 (10.6)	19.7 (15.1)	1150 (519.0)	1570 (712.4)	2010 (911.1)	2880 (1305.8)	1260 (570.2)	1730 (786.1)	2220 (1007.9)	3190 (1449.3)
72 (1800)	8.8 (6.7)	12.2 (9.3)	15.5 (11.9)	22.2 (17.0)	1520 (689.9)	2120 (962.1)	2690 (1222.5)	3880 (1761.3)	1710 (777.0)	2400 (1088.2)	3050 (1384.8)	4410 (2001.0)
78 (1950)	11.4 (8.7)	15.8 (12.1)	20.1 (15.4)	28.9 (22.1)	1750 (791.1)	2400 (1090.7)	3100 (1409.0)	4490 (2039.7)	1950 (885.5)	2700 (1223.1)	3490 (1583.9)	5060 (2298.9)
84 (2100)	12.6 (9.6)	17.4 (13.3)	22.3 (17.0)	32.1 (24.5)	1900 (862.7)	2680 (1217.4)	3430 (1558.6)	4960 (2254.4)	2120 (959.6)	3000 (1359.6)	3840 (1743.2)	5560 (2526.8)

① For cast-in-place construction, increase concrete volumes by approximately 12%.

Illinois Department of Transportation

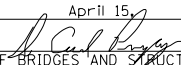
APPROVED April 15, 2016

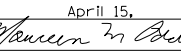
 ENGINEER OF BRIDGES AND STRUCTURES

APPROVED April 15, 2016

 ENGINEER OF DESIGN AND ENVIRONMENT

ISSUED 1-1-97

**CONCRETE END SECTIONS FOR PIPE CULVERTS
 15" (375 mm) THRU 84" (2100 mm) DIA.**

(Sheet 3 of 3)

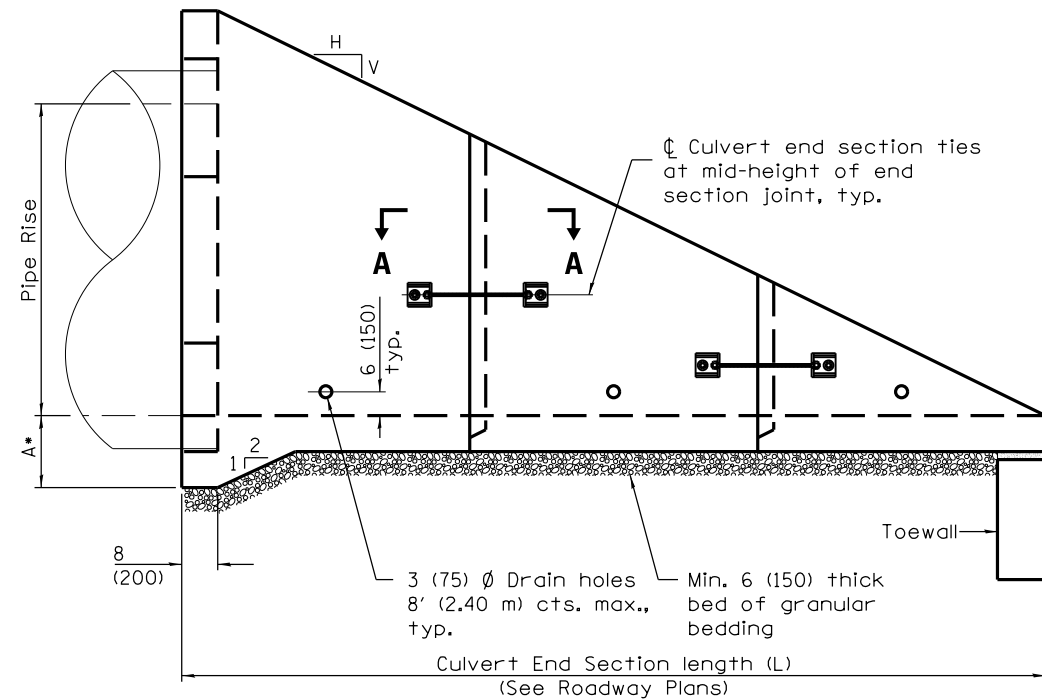
STANDARD 542001-06



ELEVATION

* This dimension shall be increased by 1/2 (38) for CIP field construction.

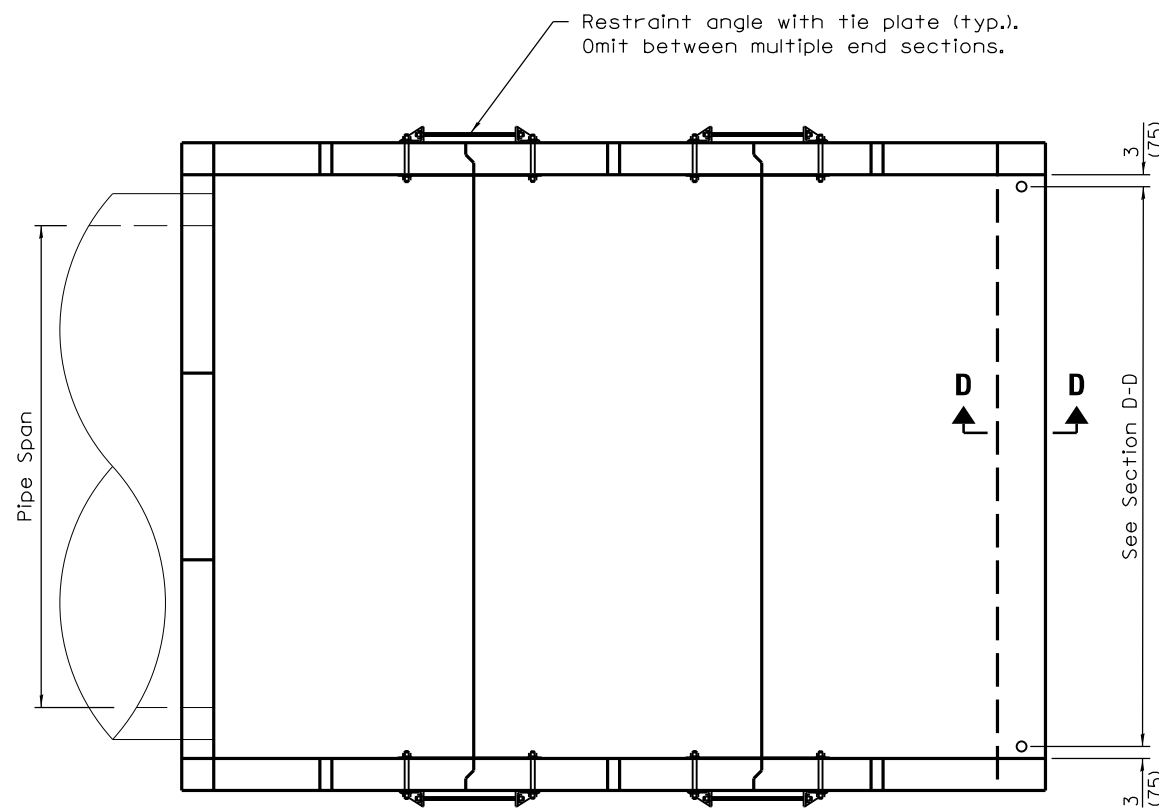

PLAN

8 (200) min. for EORS < 21 (525)
12 (300) min. for EORS ≥ 21 (525)

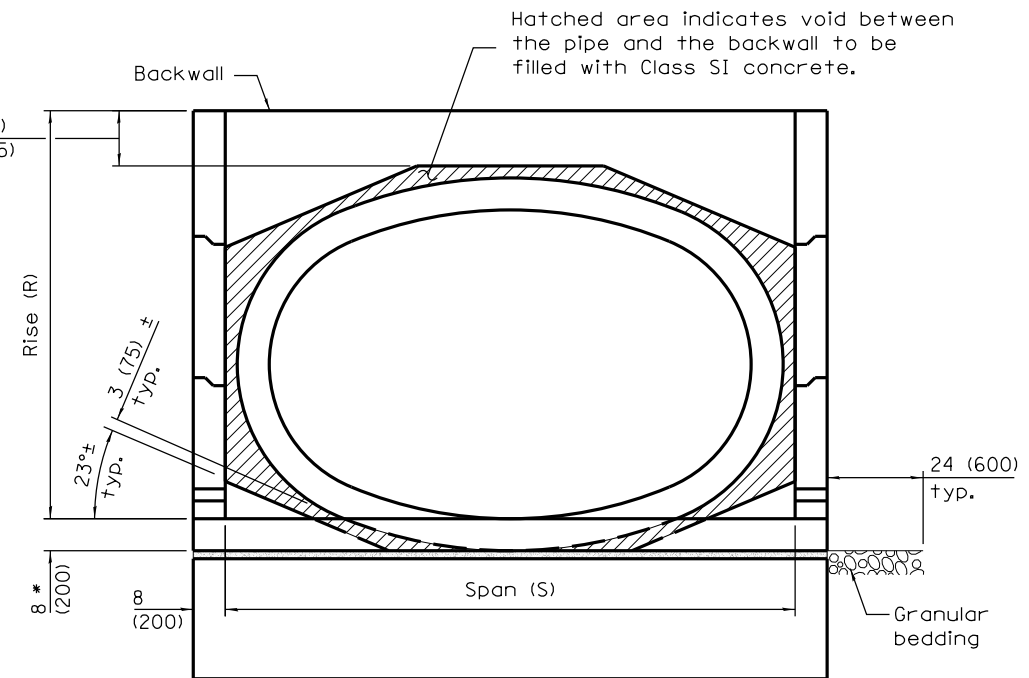

END VIEW

PIPE CULVERT END SECTION DIMENSIONS

Equivalent Round Size Pipe I.D.	Pipe Span	Pipe Rise	A	R	S	L			
						Slope of End Section			
						1:2	1:3	1:4	1:6
15 (375)	23 (575)	14 (350)	15 (375)	28 (711)	36 (914)	5'-4" (1.62 m)	7'-8" (2.34 m)	10'-0" (3.05 m)	14'-8" (4.47 m)
18 (450)	23 (575)	14 (350)	15 (375)	28 (711)	36 (914)	5'-4" (1.62 m)	7'-8" (2.34 m)	10'-0" (3.05 m)	14'-8" (4.47 m)
21 (525)	30 (750)	19 (475)	15 (375)	38 (365)	3'-8" (1.12 m)	7'-0" (2.14 m)	10'-2" (3.10 m)	13'-4" (4.07 m)	19'-8" (6.00 m)
24 (600)	30 (750)	19 (475)	15 (375)	38 (965)	3'-8" (1.12 m)	7'-0" (2.14 m)	10'-2" (3.10 m)	13'-4" (4.07 m)	19'-8" (6.00 m)
27 (675)	34 (850)	22 (550)	15 (375)	3'-5" (1.04 m)	4'-0" (1.22 m)	7'-6" (2.29 m)	10'-11" (3.33 m)	14'-4" (4.38 m)	21'-2" (6.46 m)
30 (750)	38 (950)	24 (600)	15 (375)	3'-7" (1.09 m)	4'-4" (1.32 m)	7'-10" (2.39 m)	11'-5" (3.48 m)	15'-0" (4.57 m)	22'-2" (6.75 m)
36 (900)	45 (1125)	29 (725)	16 (400)	4'-1" (1.24 m)	5'-0" (1.52 m)	8'-10" (2.69 m)	12'-11" (3.94 m)	17'-0" (5.18 m)	25'-2" (7.67 m)
42 (1050)	53 (1325)	34 (850)	16 (400)	4'-6" (1.37 m)	5'-10" (1.78 m)	9'-8" (2.95 m)	14'-2" (4.32 m)	18'-8" (5.69 m)	27'-8" (8.44 m)
48 (1200)	60 (1500)	38 (950)	17 (425)	4'-11" (1.50 m)	6'-6" (1.98 m)	10'-6" (3.20 m)	15'-5" (4.71 m)	20'-4" (6.21 m)	30'-2" (9.21 m)
54 (1350)	68 (1700)	43 (1075)	17 (425)	5'-4" (1.63 m)	7'-2" (2.18 m)	11'-4" (3.45 m)	16'-8" (5.08 m)	22'-0" (6.71 m)	32'-8" (9.96 m)
60 (1500)	76 (1900)	48 (1200)	18 (450)	5'-10" (1.78 m)	8'-0" (2.44 m)	12'-4" (3.76 m)	18'-2" (5.54 m)	24'-0" (7.32 m)	35'-8" (10.87 m)
66 (1650)	83 (2075)	53 (1325)	18 (450)	6'-3" (1.91 m)	8'-8" (2.64 m)	13'-2" (4.02 m)	19'-5" (5.92 m)	25'-8" (7.83 m)	38'-2" (11.64 m)
72 (1800)	91 (2275)	58 (1450)	19 (475)	6'-9" (2.06 m)	9'-4" (2.84 m)	14'-2" (4.32 m)	20'-11" (6.38 m)	27'-8" (8.44 m)	41'-2" (12.56 m)

See Sheet 3 for GENERAL NOTES.

DATE	REVISIONS
4-15-16	Added general note for multiple end sections.
4-1-16	Added note to omit restraint angle and tie plate for mult. end sections.

CONCRETE END SECTIONS FOR ELLIPTICAL PIPE CULVERTS 15" (375 mm) THRU 72" (1800 mm) EQUIVALENT DIAMETER

(Sheet 1 of 3)

STANDARD 542011-02

Illinois Department of Transportation

APPROVED April 15, 2016
ENGINEER OF BRIDGES AND STRUCTURES

APPROVED April 15, 2016
ENGINEER OF DESIGN AND ENVIRONMENT

ISSUED 1-1-13

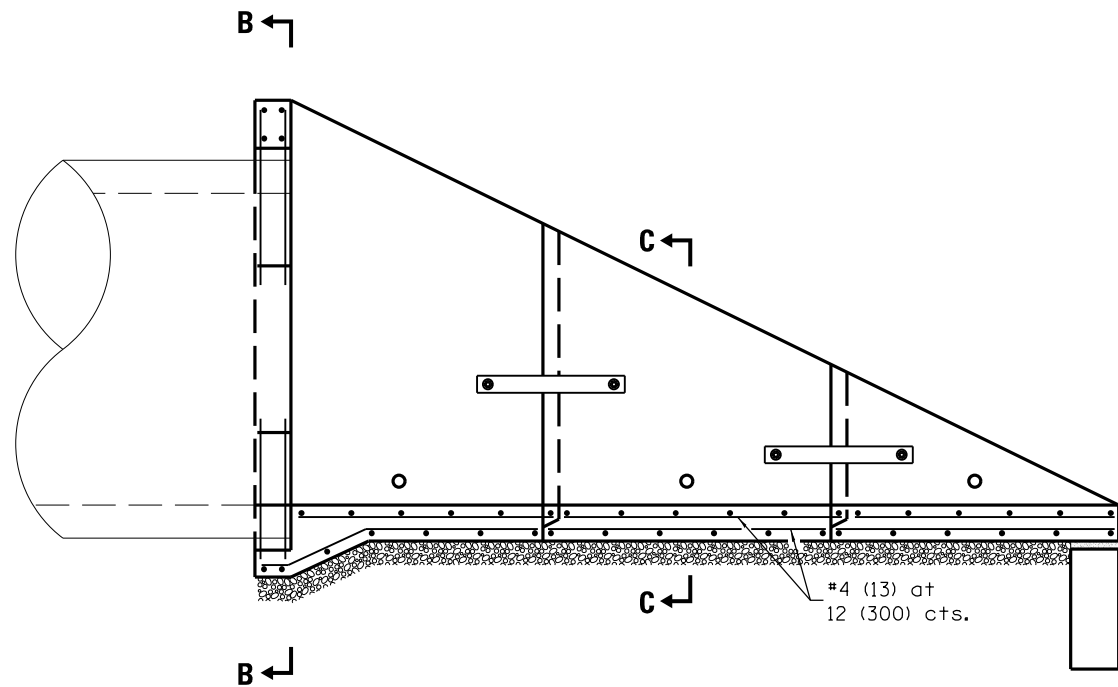

LONGITUDINAL SECTION
(Showing bottom slab and backwall reinforcement.)

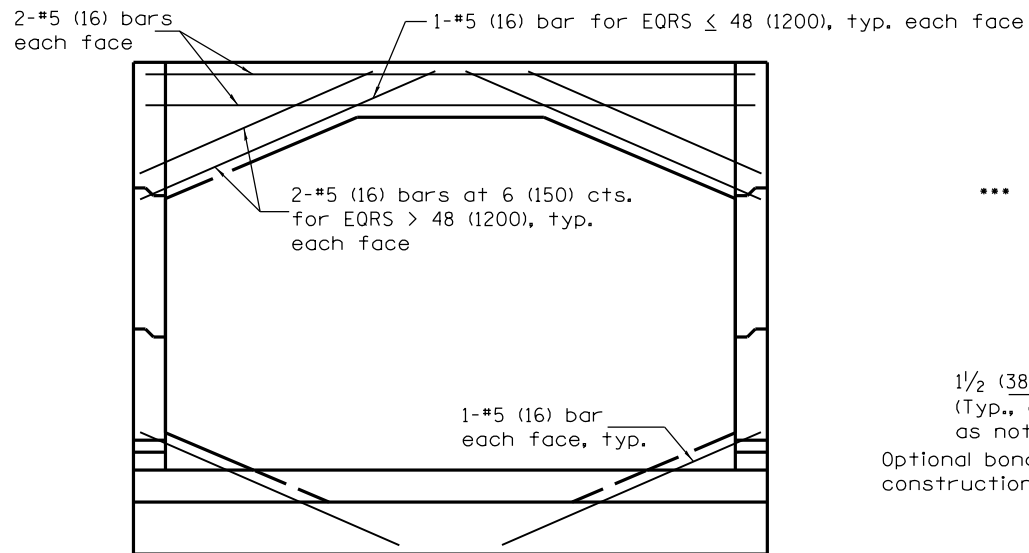

SECTION B-B
(Showing backwall reinforcement only.)
(Pipe omitted for clarity.)

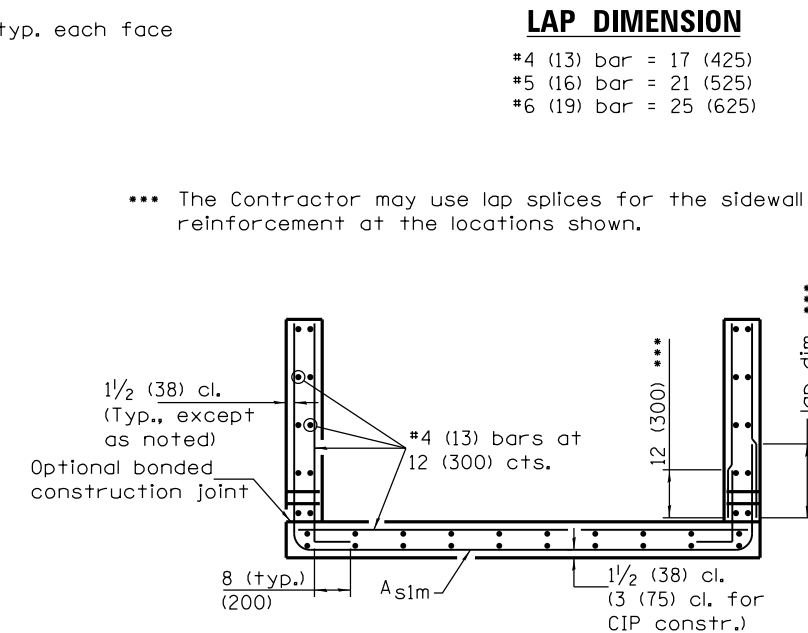

SECTION C-C

LAP DIMENSION

- #4 (13) bar = 17 (425)
- #5 (16) bar = 21 (525)
- #6 (19) bar = 25 (625)

*** The Contractor may use lap splices for the sidewall reinforcement at the locations shown.

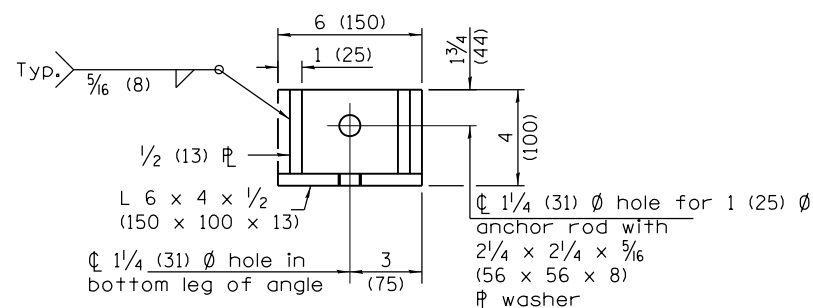

RESTRAINT ANGLE DETAIL

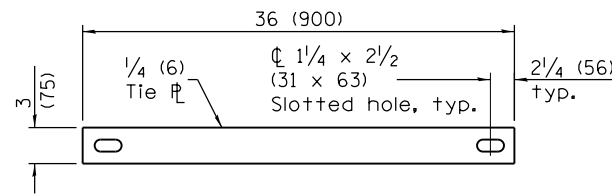

TIE PLATE DETAIL

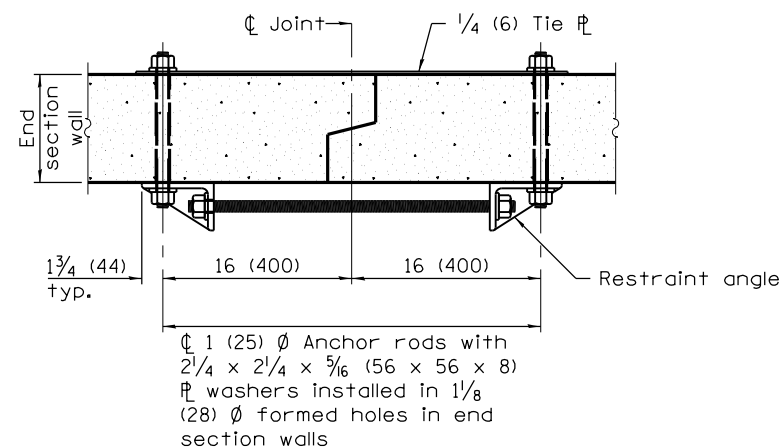

SECTION A-A
(Showing end section tie details.)

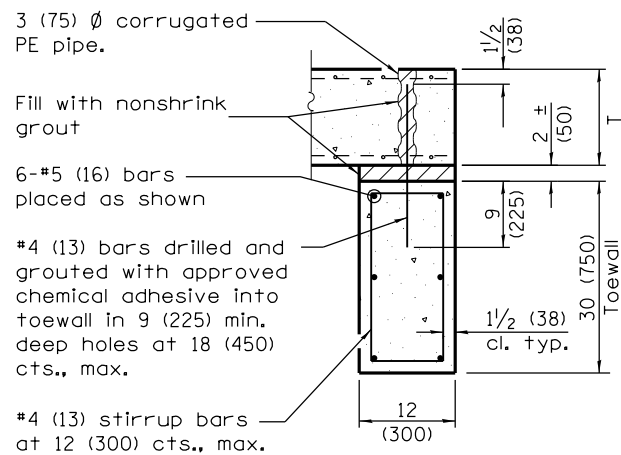

SECTION D-D

REINFORCEMENT SCHEDULE

Equivalent Round Size Pipe I.D.	A _{s1m}	
	Bar Size	Bar Spacing
15 (375)	4 (13)	12 (300)
18 (450)	4 (13)	12 (300)
21 (525)	4 (13)	12 (300)
24 (600)	4 (13)	12 (300)
27 (700)	4 (13)	12 (300)
30 (750)	4 (13)	12 (300)
36 (900)	4 (13)	12 (300)
42 (1050)	4 (13)	12 (300)
48 (1200)	4 (13)	8 (200)
54 (1350)	4 (13)	8 (200)
60 (1500)	4 (13)	8 (200)
66 (1650)	5 (16)	8 (200)
72 (1800)	5 (16)	8 (200)

CONCRETE END SECTIONS FOR ELLIPTICAL PIPE CULVERTS 15" (375 mm) THRU 72" (1800 mm) EQUIVALENT DIAMETER

(Sheet 2 of 3)

STANDARD 542011-02

Illinois Department of Transportation

APPROVED April 15, 2016
[Signature]
 ENGINEER OF BRIDGES AND STRUCTURES

APPROVED April 15, 2016
[Signature]
 ENGINEER OF DESIGN AND ENVIRONMENT

ISSUED 1-1-13

QUANTITIES

Equivalent Round Size Pipe I.D.	Concrete yd ³ (m ³) ①				Reinforcement Without Lap lbs. (kg)				Reinforcement With Lap lbs (kg)			
	Slope of End Section				Slope of End Section				Slope of End Section			
	1:2	1:3	1:4	1:6	1:2	1:3	1:4	1:6	1:2	1:3	1:4	1:6
15 (375)	1.5 (1.1)	1.9 (1.6)	2.3 (1.8)	3.0 (2.3)	220 (120.8)	270 (148.3)	320 (172.9)	420 (228.5)	240 (132.3)	300 (164.3)	350 (192.8)	470 (257.4)
18 (450)	1.5 (1.3)	1.9 (1.6)	2.3 (1.8)	3.0 (2.3)	220 (120.8)	270 (148.3)	320 (172.9)	420 (228.5)	240 (132.3)	300 (164.3)	350 (192.8)	470 (257.4)
21 (525)	2.2 (1.7)	2.8 (2.1)	3.5 (2.7)	4.8 (3.7)	310 (167.2)	390 (172.9)	470 (211.5)	630 (285.2)	330 (181.8)	420 (189.3)	520 (232.9)	700 (316.3)
24 (600)	2.2 (1.7)	2.8 (2.1)	3.5 (2.7)	4.8 (3.7)	310 (167.2)	390 (172.9)	470 (211.5)	630 (285.2)	330 (181.8)	420 (189.3)	520 (232.9)	700 (316.3)
27 (700)	2.5 (1.9)	3.2 (2.4)	3.9 (3.0)	5.4 (4.1)	330 (181.7)	420 (190.1)	510 (231.4)	690 (310.5)	360 (197.0)	460 (208.0)	560 (254.3)	760 (343.1)
30 (750)	2.7 (2.1)	3.5 (2.7)	4.3 (3.3)	5.9 (4.5)	350 (193.1)	450 (201.9)	540 (244.9)	730 (331.3)	380 (209.5)	490 (220.4)	600 (268.7)	810 (365.3)
36 (900)	3.3 (2.5)	4.4 (3.4)	5.4 (4.1)	7.5 (5.7)	430 (237.6)	560 (252.2)	690 (309.3)	940 (423.4)	470 (255.8)	610 (273.0)	740 (335.9)	1020 (461.8)
42 (1050)	4.0 (3.1)	5.3 (4.1)	6.6 (5.0)	9.2 (7.0)	510 (279.8)	660 (295.6)	820 (369.1)	1120 (508.5)	550 (299.8)	700 (317.9)	880 (398.7)	1220 (551.3)
48 (1200)	4.7 (3.6)	6.2 (4.7)	7.8 (6.0)	10.9 (8.3)	660 (362.5)	870 (391.5)	1070 (485.4)	1490 (672.8)	710 (389.5)	940 (422.8)	1160 (525.7)	1610 (731.4)
54 (1350)	5.3 (4.1)	7.2 (5.5)	9.0 (6.9)	12.6 (9.6)	730 (400.1)	960 (434.4)	1190 (540.2)	1670 (756.6)	780 (428.9)	1030 (467.9)	1290 (583.7)	1810 (820.5)
60 (1500)	6.3 (4.8)	8.5 (6.5)	10.7 (8.2)	15.1 (11.5)	830 (458.1)	1110 (500.0)	1390 (629.0)	1950 (882.2)	890 (488.7)	1180 (535.9)	1490 (676.2)	2100 (951.4)
66 (1650)	7.1 (5.4)	9.6 (7.3)	12.2 (9.3)	17.2 (13.2)	1080 (596.0)	1470 (665.5)	1840 (836.2)	2610 (1185.3)	1180 (650.1)	1610 (729.0)	2030 (918.3)	2880 (1306.3)
72 (1800)	8.2 (6.3)	11.1 (8.5)	14.0 (10.7)	19.8 (14.9)	1190 (653.9)	1620 (734.2)	2050 (931.6)	2930 (1328.9)	1290 (710.7)	1770 (801.7)	2250 (1019.9)	3220 (1460.0)

① For cast-in-place construction, increase concrete volumes by approximately 13%.

GENERAL NOTES

This Standard is used with single pipe culverts and multi-pipe culvert installations. For multi-pipe culvert installations, place the end sections side-by-side leaving a 3 (75) space between adjacent end section walls and fill the space(s) with Class SI concrete.

The number of segments shown in elevation is for example only. The length and number of precast sections required to construct the end section shall be determined by the Contractor.

See roadway plans for slope (V:H) and pipe inside diameter.

End section may be installed up to ± 15 degrees skewed with roadway.

2/4 x 2/4 x 5/16 (56 x 56 x 8) plate washers shall be provided under each nut required for the anchor rods. Holes in the walls for the culvert tie assembly may be drilled using core bits in lieu of formed holes.

See Standard 542311 for end sections having traversable pipe grate.

All slope ratios are expressed as units of vertical displacement to units of horizontal displacement (V:H).

All dimensions are in inches (millimeters) unless otherwise shown.

CONCRETE END SECTIONS FOR ELLIPTICAL PIPE CULVERTS 15" (375 mm) THRU 72" (1800 mm) EQUIVALENT DIAMETER

(Sheet 3 of 3)

STANDARD 542011-02

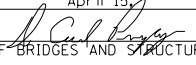
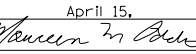
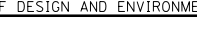
 Illinois Department of Transportation	ISSUED 1-1-13
APPROVED <u>April 15, 2016</u>  ENGINEER OF BRIDGES AND STRUCTURES	
APPROVED <u>April 15, 2016</u>  ENGINEER OF DESIGN AND ENVIRONMENT	
APPROVED <u>April 15, 2016</u>  ENGINEER OF DESIGN AND ENVIRONMENT	

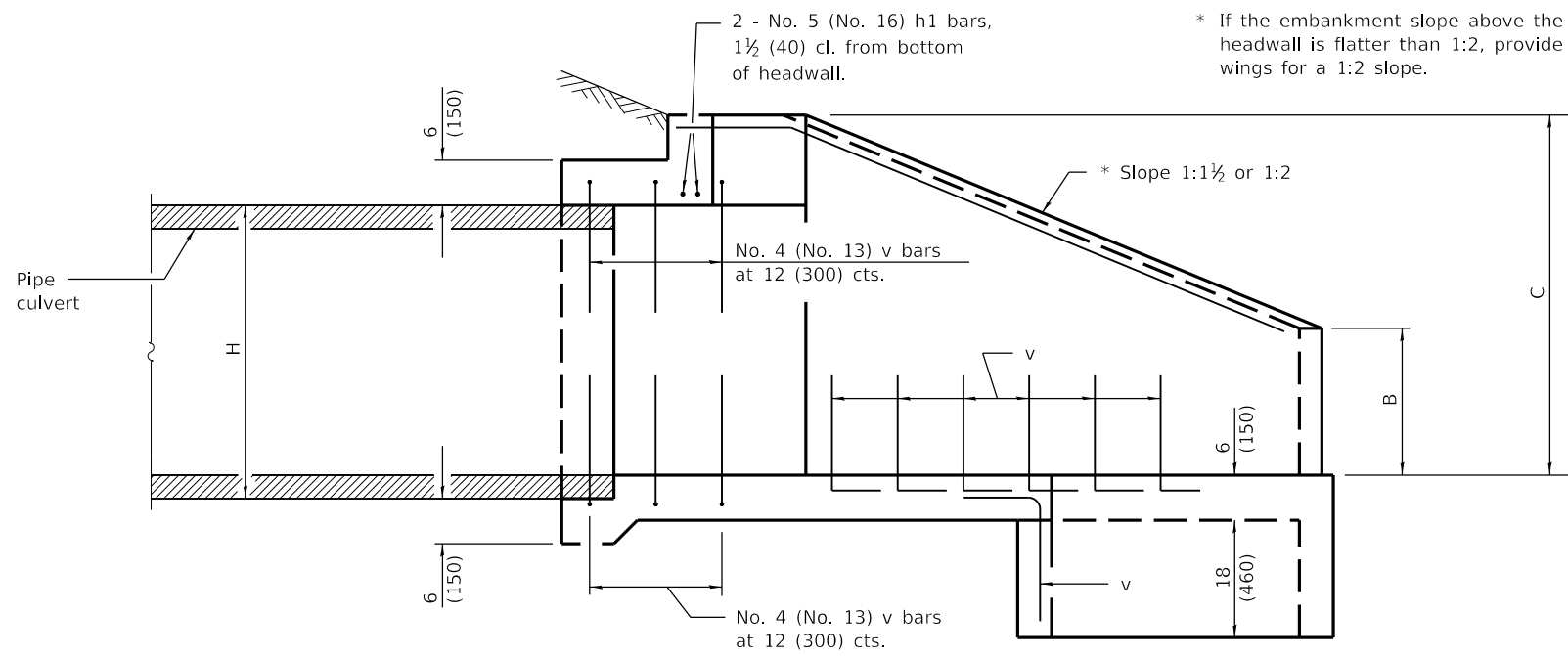

SECTION A-A

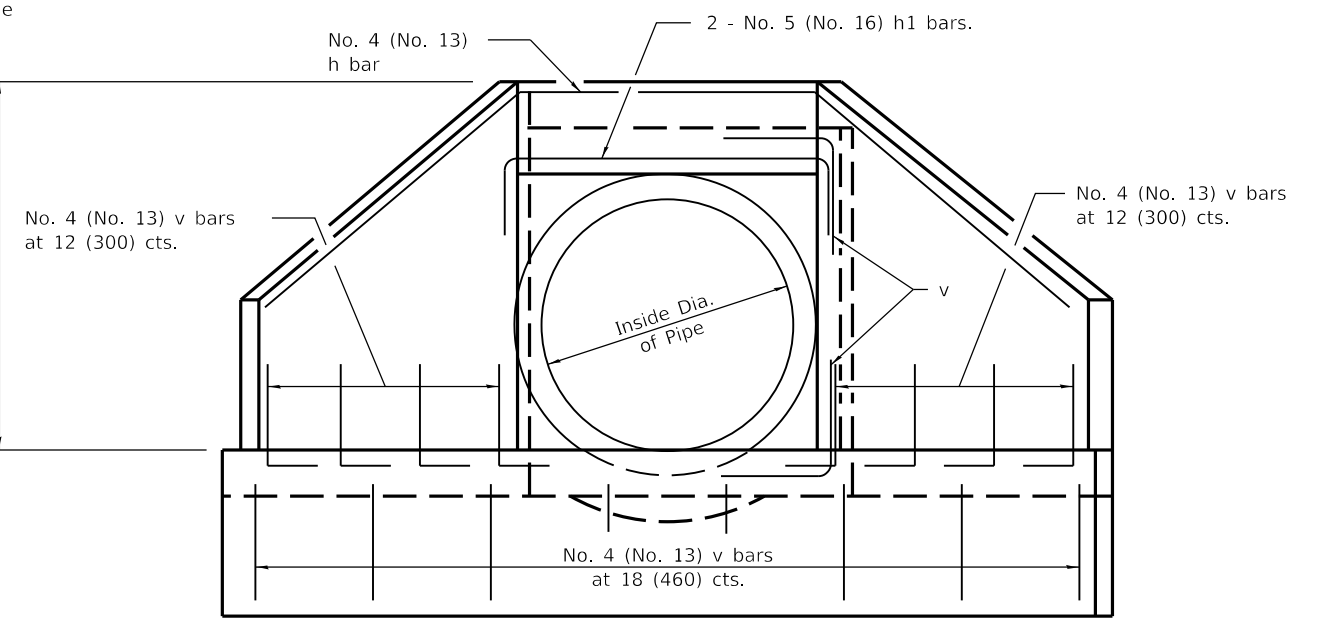

END VIEW

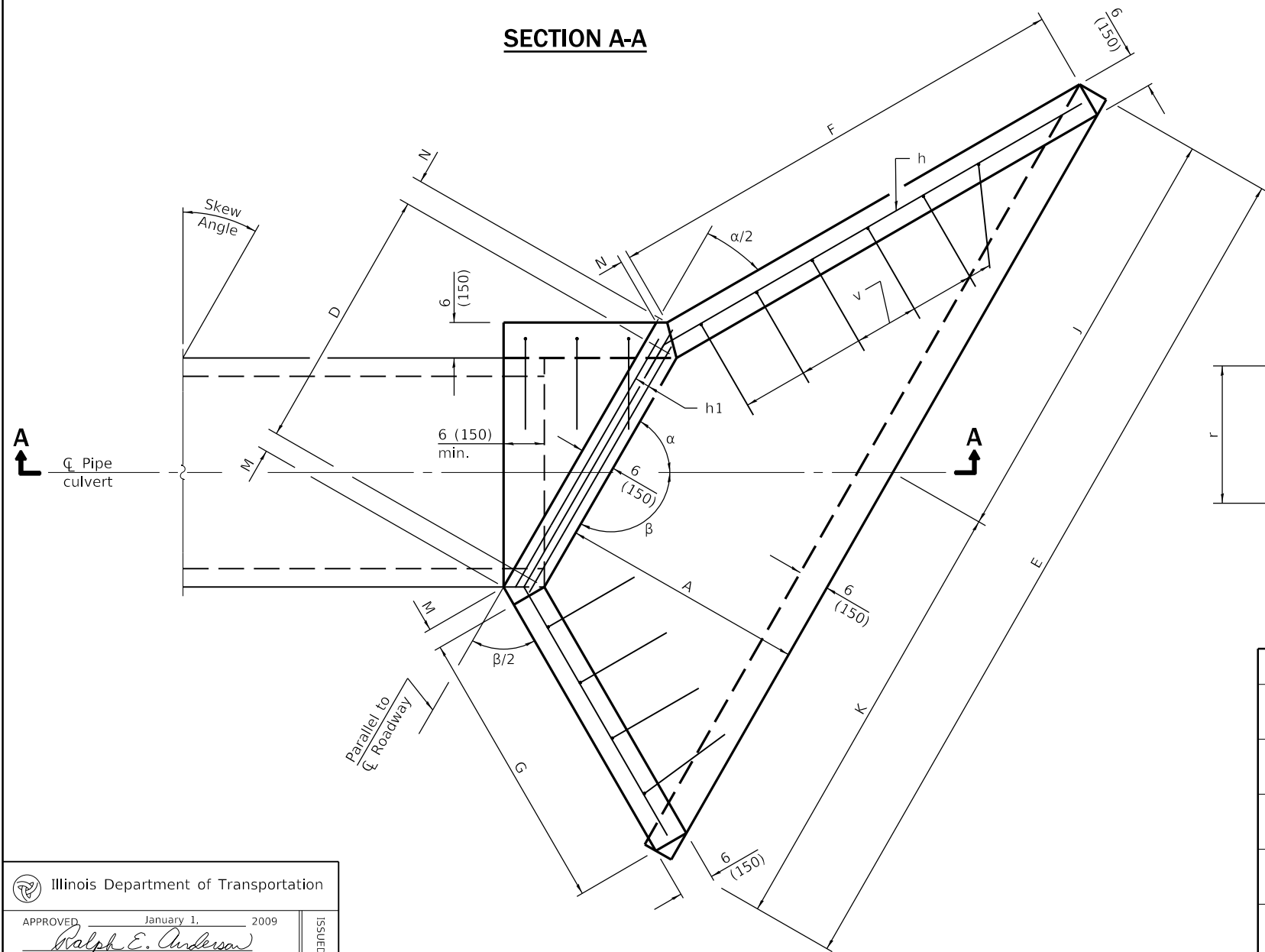

PLAN

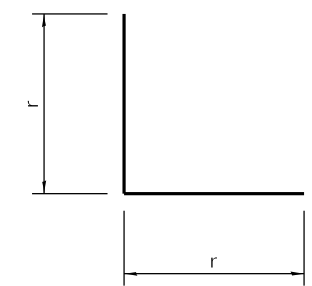

BAR - v

Dia.	r
15 (375)	21 (551)
18 (450)	24 (626)
24 (600)	30 (765)
30 (750)	36 (917)
36 (900)	3'-6" (1.08 m)

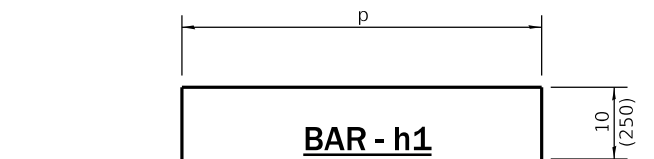

BAR - h1

Bent in field, two req. for each headwall.

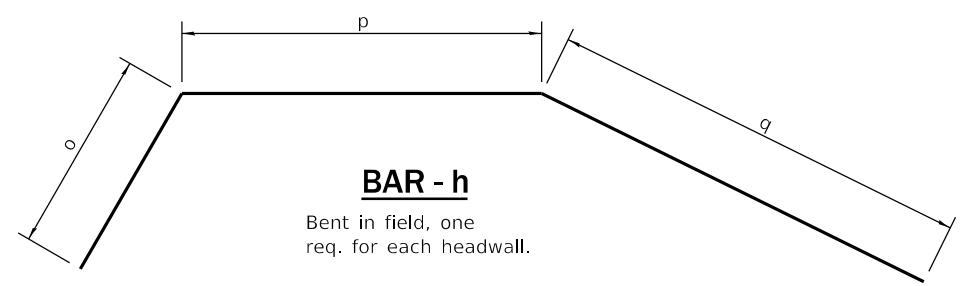

BAR - h

Bent in field, one req. for each headwall.

GENERAL NOTES

Build tops of headwalls parallel to grade line.
 All slope ratios are expressed as units of vertical displacement to units of horizontal displacement (V:H).
 All dimensions are in inches (millimeters) unless otherwise shown.

DATE	REVISIONS
1-1-09	Switched units to English (metric).
1-1-07	Soft converted metric reinforcement bars.
	Added h bars.

**REINFORCED CONCRETE END SECTIONS
 FOR PIPE CULVERTS
 15" (375 mm) THRU 36" (900 mm) DIA.
 SKEWED WITH ROADWAY**

(Sheet 1 of 5)

STANDARD 542201-02

Illinois Department of Transportation

APPROVED January 1, 2009
Ralph E. Anderson
 ENGINEER OF BRIDGES AND STRUCTURES

APPROVED January 1, 2009
Lee E. Han
 ENGINEER OF DESIGN AND ENVIRONMENT

ISSUED 1-1-97

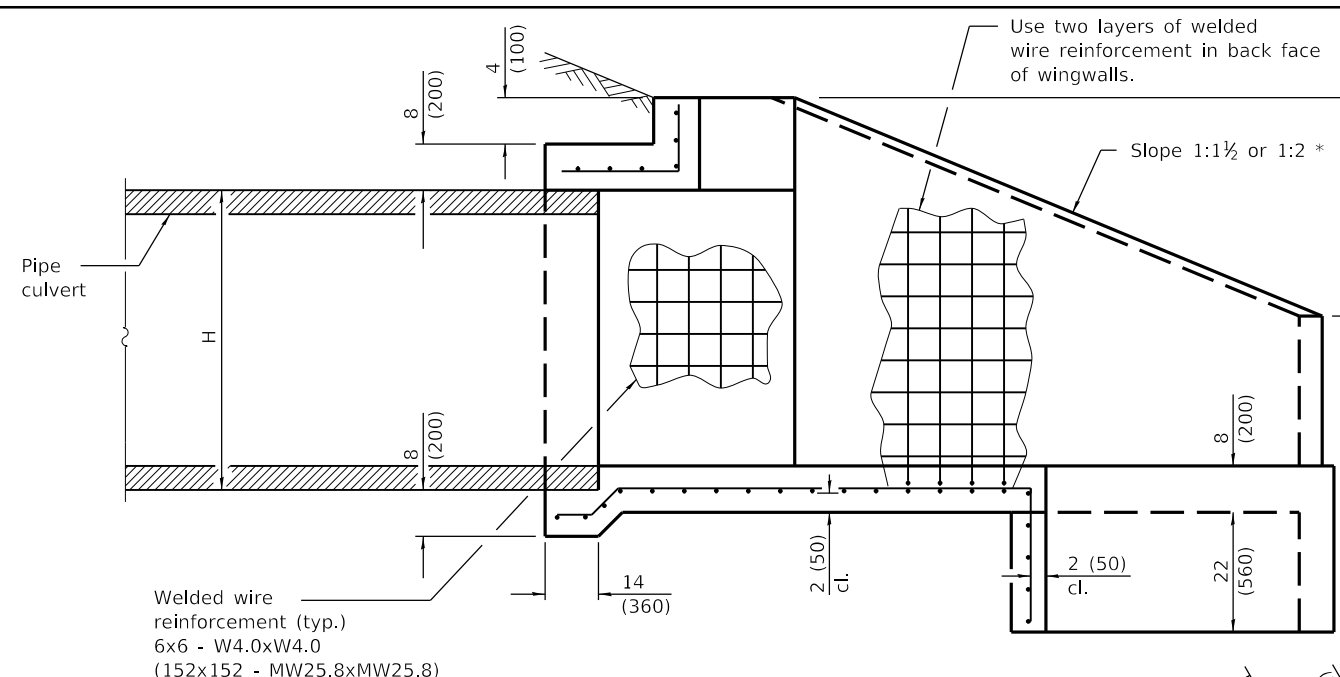

SECTION A-A

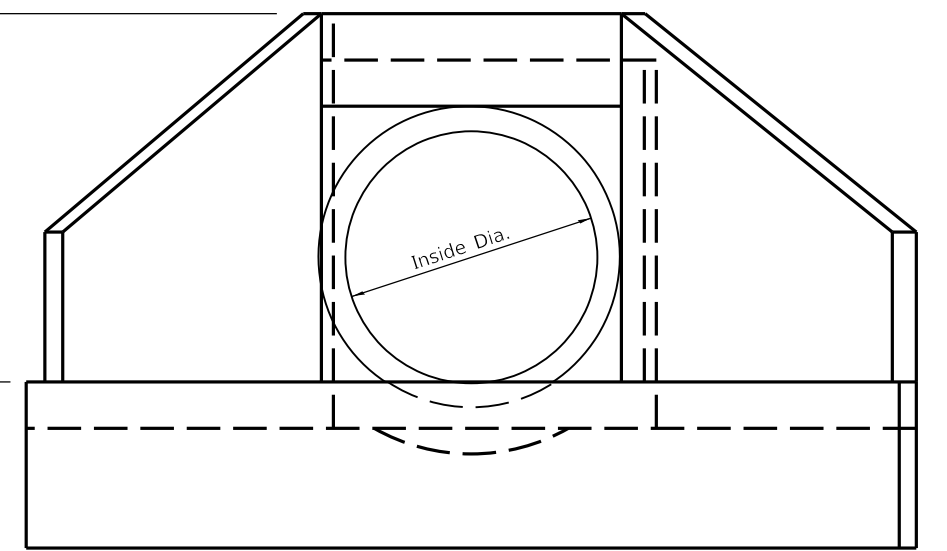

END VIEW

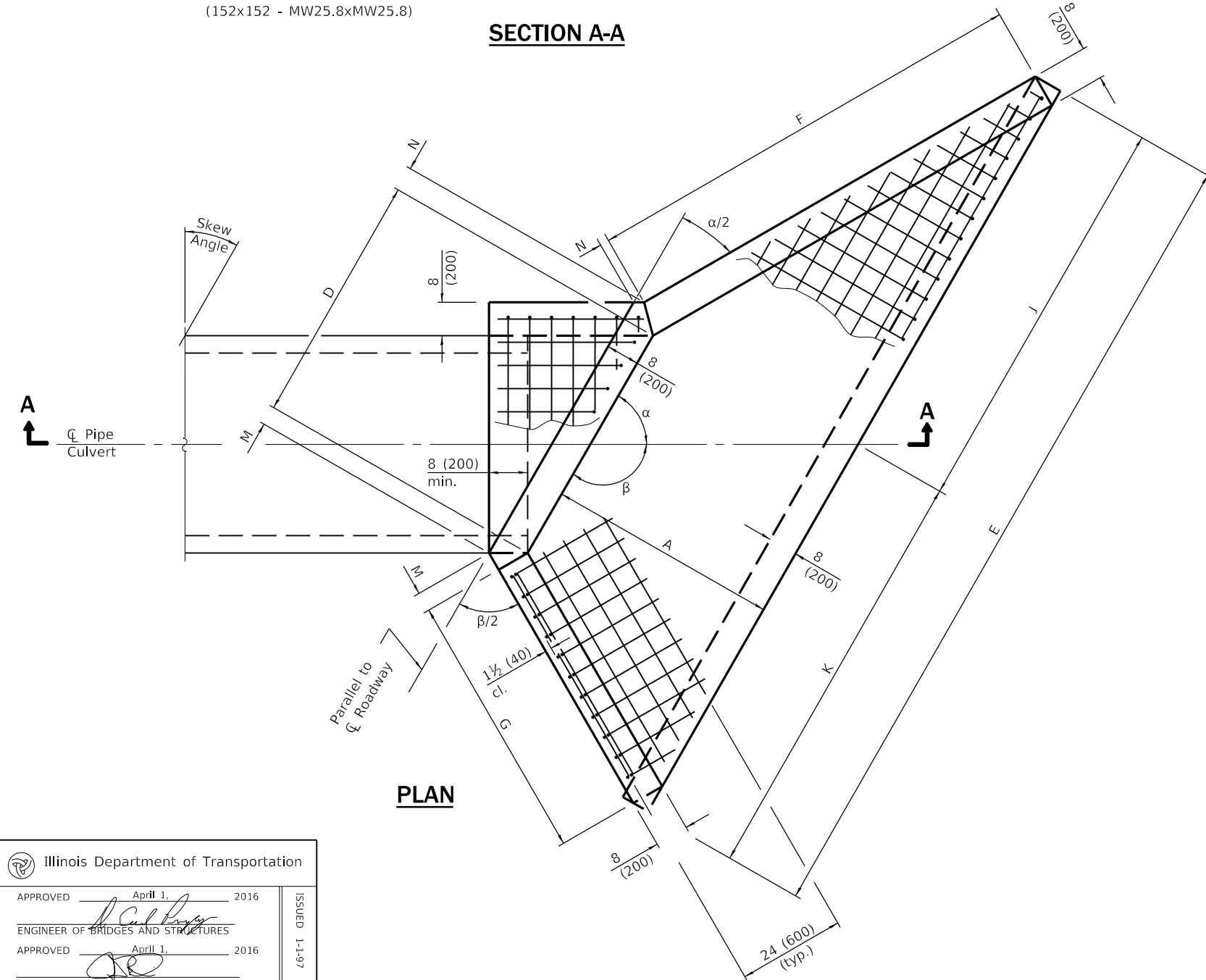

PLAN

GENERAL NOTES

Build tops of headwalls parallel to grade line.

When lapping sheets of welded wire reinforcement, the overlap measured between the outermost cross wires of each reinforcement sheet shall not be less than 8 (200).

All slope ratios are expressed as units of vertical displacement to units of horizontal displacement (V:H).

All dimensions are in inches (millimeters) unless otherwise shown.

Illinois Department of Transportation

APPROVED April 1, 2016

ENGINEER OF BRIDGES AND STRUCTURES

APPROVED April 1, 2016

ENGINEER OF DESIGN AND ENVIRONMENT

ISSUED 1-1-97

DATE	REVISIONS
4-1-16	Changed terminology to 'welded wire reinforcement'.
1-1-14	Corrected skew angles in table on Sheet 5.

**REINFORCED CONCRETE END SECTIONS
FOR PIPE CULVERTS
42" (1050 mm) THRU 60" (1500 mm) DIA.
SKEWED WITH ROADWAY**

(Sheet 1 of 5)

STANDARD 542206-04

WINGS FOR 1:1 1/2 SLOPE

Skew Angle	Nominal Pipe Dia.	Dimensions for Concrete													Concrete 2 End Secs. cu. yd. (m ³)	Welded Wire Reinforcement 2 End Secs. sq. yd. (m ²)
		A	B	C	D	E	F	G	H	J	K	M	N	α		
5°	42 (1050)	4'-1"	26 (660)	4'-10 1/2"	4'-3 1/4"	13'-5"	6'-0 1/2"	5'-6 1/2"	4'-3"	6'-8 1/4"	6'-8 3/4"	3 1/2 (90)	3 (80)	85°	6.0 (4.6)	46 (38)
	48 (1200)	4'-6"	29 (740)	5'-5"	4'-10 1/4"	14'-10"	6'-8"	6'-1 1/4"	4'-10"	7'-4 3/4"	7'-5 1/4"	3 1/2 (90)	3 (80)	85°	7.2 (5.5)	53 (44)
	54 (1350)	4'-11"	32 (810)	5'-11 1/2"	5'-5 1/4"	16'-3"	7'-3 1/4"	6'-8"	5'-5"	8'-1 1/4"	8'-1 1/4"	3 1/2 (90)	3 (80)	85°	8.4 (6.4)	65 (55)
	60 (1500)	5'-4"	35 (890)	6'-6"	6'-0 1/4"	17'-8"	7'-10 3/4"	7'-2 3/4"	6'-0"	8'-9 3/4"	8'-10 1/4"	3 1/2 (90)	3 (80)	85°	9.8 (7.5)	71 (59)
10°	42 (1050)	4'-1"	26 (660)	4'-10 1/2"	4'-3 3/4"	13'-6 1/2"	6'-4 1/4"	5'-4"	4'-3"	6'-8 3/4"	6'-9 3/4"	3 3/4 (100)	3 (80)	80°	6.3 (4.8)	47 (39)
	48 (1200)	4'-6"	29 (740)	5'-5"	4'-11"	15'-0"	7'-0"	5'-10 1/2"	4'-10"	7'-5 1/2"	7'-6 1/2"	3 3/4 (100)	3 (80)	80°	7.5 (5.7)	54 (45)
	54 (1350)	4'-11"	32 (810)	5'-11 1/2"	5'-6"	16'-5"	7'-7 3/4"	6'-5"	5'-5"	8'-2"	8'-3"	3 3/4 (100)	3 (80)	80°	8.8 (6.7)	66 (56)
	60 (1500)	5'-4"	35 (890)	6'-6"	6'-1"	17'-10 1/2"	8'-3 1/2"	6'-11 1/2"	6'-0"	8'-10 3/4"	8'-11 3/4"	3 3/4 (100)	3 (80)	80°	10.3 (7.9)	73 (61)
15°	42 (1050)	4'-1"	26 (660)	4'-10 1/2"	4'-4 3/4"	13'-9 1/2"	6'-8 1/2"	5'-1 3/4"	4'-3"	6'-10"	6'-11 1/2"	4 (100)	2 1/4 (70)	75°	6.6 (5.0)	48 (40)
	48 (1200)	4'-6"	29 (740)	5'-5"	5'-0"	15'-3"	7'-4 3/4"	5'-8"	4'-10"	7'-6 3/4"	7'-8 1/4"	4 (100)	2 3/4 (70)	75°	7.9 (6.0)	55 (46)
	54 (1350)	4'-11"	32 (810)	5'-11 1/2"	5'-7 1/4"	16'-8 3/4"	8'-1"	6'-2 1/4"	5'-5"	8'-3 3/4"	8'-5"	4 (100)	2 3/4 (70)	75°	9.3 (7.1)	68 (57)
	60 (1500)	5'-4"	35 (890)	6'-6"	6'-2 1/2"	18'-2 1/4"	8'-9 1/4"	6'-8 3/4"	6'-0"	9'-0 1/2"	9'-1 1/4"	4 (100)	2 3/4 (70)	75°	10.8 (8.3)	75 (62)
20°	42 (1050)	4'-1"	26 (660)	4'-10 1/2"	4'-6 1/4"	14'-1 1/4"	7'-1 1/2"	4'-11 3/4"	4'-3"	7'-0"	7'-1 3/4"	4 1/4 (105)	2 1/2 (70)	70°	7.0 (5.4)	49 (41)
	48 (1200)	4'-6"	29 (740)	5'-5"	5'-1 3/4"	15'-7 3/4"	7'-10 1/4"	5'-6"	4'-10"	7'-9"	7'-10 3/4"	4 1/4 (105)	2 1/2 (70)	70°	8.4 (6.4)	57 (48)
	54 (1350)	4'-11"	32 (810)	5'-11 1/2"	5'-9 1/4"	17'-2"	8'-6 3/4"	6'-0"	5'-5"	8'-6"	8'-8"	4 1/4 (105)	2 1/2 (70)	70°	9.9 (7.6)	70 (59)
	60 (1500)	5'-4"	35 (890)	6'-6"	6'-4 1/2"	18-8"	9'-3 1/2"	6'-6 1/4"	6'-0"	9'-3"	9'-5"	4 1/4 (105)	2 1/2 (70)	70°	11.5 (8.8)	77 (64)
25°	42 (1050)	4'-1"	26 (660)	4'-10 1/2"	4'-8 1/4"	14'-7 1/2"	7'-7 1/4"	4'-10"	4'-3"	7'-2 1/2"	7'-5"	4 1/2 (110)	2 1/4 (60)	65°	7.4 (5.7)	51 (43)
	48 (1200)	4'-6"	29 (740)	5'-5"	5'-4"	16'-2 1/4"	8'-4 1/2"	5'-4"	4'-10"	8'-0"	8'-2 1/4"	4 1/2 (110)	2 1/4 (60)	65°	8.9 (6.8)	59 (49)
	54 (1350)	4'-11"	32 (810)	5'-11 1/2"	5'-11 3/4"	17'-9"	9'-1 3/4"	5'-10"	5'-5"	8'-9 1/4"	8'-11 3/4"	4 1/2 (110)	2 1/4 (60)	65°	10.5 (8.0)	73 (61)
	60 (1500)	5'-4"	35 (890)	6'-6"	6'-7 1/2"	19'-3 3/4"	9'-11"	6'-4"	6'-0"	9'-6 3/4"	9'-9"	4 1/2 (110)	2 1/4 (60)	65°	12.2 (9.3)	80 (67)
30°	42 (1050)	4'-1"	26 (660)	4'-10 1/2"	4'-11"	15'-3"	8'-2"	4'-8 1/2"	4'-3"	7'-6"	7'-9"	4 1/2 (120)	2 1/4 (60)	60°	7.9 (6.0)	53 (45)
	48 (1200)	4'-6"	29 (740)	5'-5"	5'-7"	16'-10 1/2"	9'-0"	5'-2 1/2"	4'-10"	8'-3 3/4"	8'-6 3/4"	4 1/2 (120)	2 1/4 (60)	60°	9.5 (7.3)	62 (52)
	54 (1350)	4'-11"	32 (810)	5'-11 1/2"	6'-3"	18'-6 1/4"	9'-10"	5'-8"	5'-5"	9'-1 3/4"	9'-4 1/2"	4 1/2 (120)	2 1/4 (60)	60°	11.2 (8.6)	77 (64)
	60 (1500)	5'-4"	35 (890)	6'-6"	6'-11 1/4"	20'-2"	10'-8"	6'-2"	6'-0"	9'-11 1/2"	10'-2 1/2"	4 1/2 (120)	2 1/4 (60)	60°	13.1 (10.0)	84 (70)

Illinois Department of Transportation
 APPROVED April 1, 2016
 ENGINEER OF BRIDGES AND STRUCTURES
 APPROVED April 1, 2016
 ENGINEER OF DESIGN AND ENVIRONMENT

ISSUED 1-1-97

**REINFORCED CONCRETE END SECTIONS
 FOR PIPE CULVERTS
 42" (1050 mm) THRU 60" (1500 mm) DIA.
 SKEWED WITH ROADWAY**
 (Sheet 2 of 5)
STANDARD 542206-04

WINGS FOR 1:1 1/2 SLOPE

Skew Angle	Nominal Pipe Dia.	Dimensions for Concrete													Concrete 2 End Secs. cu. yd. (m ³)	Welded Wire Reinforcement 2 End Secs. sq. yd. (m ²)
		A	B	C	D	E	F	G	H	J	K	M	N	α		
35°	42 (1050)	4'-1" (1.25 m)	26 (660)	4'-10 1/2" (1.49 m)	5'-2 1/4" (1.58 m)	16'-0 3/4" (4.59 m)	8'-10" (2.71 m)	4'-7 1/4" (1.41 m)	4'-3" (1.295 m)	7'-10 3/4" (2.4 m)	8'-2" (2.49 m)	4 3/4 (120)	2 (50)	55°	8.5 (6.5)	56 (47)
	48 (1200)	4'-6" (1.35 m)	29 (740)	5'-5" (1.64 m)	5'-10 3/4" (1.798 m)	17'-9 1/2" (5.36 m)	9'-9" (2.93 m)	5'-1" (1.53 m)	4'-10" (1.473 m)	8'-9" (2.64 m)	9'-0 1/2" (2.73 m)	4 3/4 (120)	2 (50)	55°	10.2 (7.8)	66 (55)
	54 (1350)	4'-11 1/2" (1.56 m)	32 (810)	5'-11 1/2" (1.85 m)	6'-7 1/4" (2.015 m)	19'-6 1/4" (6.1 m)	10'-7 3/4" (3.38 m)	5'-6 1/2" (1.76 m)	5'-5" (1.651 m)	9'-7 1/2" (3.01 m)	9'-10 3/4" (3.09 m)	4 3/4 (120)	2 (50)	55°	12.0 (9.2)	81 (68)
	60 (1500)	5'-4" (1.62 m)	35 (890)	6'-6" (1.97 m)	7'-4" (2.232 m)	21'-3" (6.46 m)	11'-6 1/2" (3.51 m)	6'-0 1/4" (1.83 m)	6'-0" (1.829 m)	10'-5 3/4" (3.19 m)	10'-9 1/4" (3.27 m)	4 3/4 (120)	2 (50)	55°	14.1 (10.8)	89 (74)
40°	42 (1050)	4'-1" (1.25 m)	26 (660)	4'-10 1/2" (1.49 m)	5'-6 1/2" (1.69 m)	17'-1 1/4" (5.21 m)	9'-8" (2.95 m)	4'-6" (1.38 m)	4'-3" (1.295 m)	8'-4 3/4" (2.56 m)	8'-8 1/2" (2.65 m)	5 (130)	1 3/4 (50)	50°	9.1 (7.0)	60 (50)
	48 (1200)	4'-6" (1.35 m)	29 (740)	5'-5" (1.64 m)	6'-3 3/4" (1.922 m)	18'-11 1/4" (5.72 m)	10'-7 3/4" (3.2 m)	4'-11 1/2" (1.49 m)	4'-10" (1.473 m)	9'-3 3/4" (2.81 m)	9'-7 1/2" (2.91 m)	5 (130)	1 3/4 (50)	50°	11.0 (8.4)	70 (58)
	54 (1350)	4'-11 1/2" (1.56 m)	32 (810)	5'-11 1/2" (1.85 m)	7'-0 3/4" (2.155 m)	20'-9 1/2" (6.5 m)	11'-7 1/2" (3.69 m)	5'-5" (1.72 m)	5'-5" (1.651 m)	10'-2 3/4" (3.2 m)	10'-6 3/4" (3.3 m)	5 (130)	1 3/4 (50)	50°	13.0 (9.9)	86 (72)
	60 (1500)	5'-4" (1.62 m)	35 (890)	6'-6" (1.97 m)	7'-10" (2.387 m)	22'-7 3/4" (6.89 m)	12'-7 1/2" (3.84 m)	6'-0" (1.79 m)	6'-0" (1.829 m)	11'-2" (3.4 m)	11'-5 3/4" (3.49 m)	5 (130)	1 3/4 (50)	50°	15.2 (11.6)	95 (79)
45°	42 (1050)	4'-1" (1.25 m)	26 (660)	4'-10 1/2" (1.49 m)	6'-0" (1.831 m)	18'-5 1/4" (5.62 m)	10'-8" (3.26 m)	4'-5" (1.35 m)	4'-3" (1.295 m)	9'-0 1/2" (2.76 m)	9'-4 3/4" (2.86 m)	5 1/4 (140)	1 1/2 (40)	45°	10.0 (7.6)	65 (54)
	48 (1200)	4'-6" (1.35 m)	29 (740)	5'-5" (1.64 m)	6'-10" (2.083 m)	20'-5 1/4" (6.17 m)	11'-9" (3.53 m)	4'-10 1/2" (1.46 m)	4'-10" (1.473 m)	10'-0 1/2" (3.03 m)	10'-4 3/4" (3.14 m)	5 1/4 (140)	1 1/2 (40)	45°	12.0 (9.2)	75 (63)
	54 (1350)	4'-11 1/2" (1.56 m)	32 (810)	5'-11 1/2" (1.85 m)	7'-8" (2.334 m)	22'-5 1/4" (7.01 m)	12'-10 1/4" (4.08 m)	5'-3 3/4" (1.69 m)	5'-5" (1.651 m)	11'-0 1/2" (3.45 m)	11'-4 3/4" (3.56 m)	5 1/4 (140)	1 1/2 (40)	45°	14.2 (10.9)	93 (78)
	60 (1500)	5'-4" (1.62 m)	35 (890)	6'-6" (1.97 m)	8'-5 3/4" (2.586 m)	24'-5 1/4" (7.43 m)	13'-11 1/4" (4.24 m)	5'-9 1/4" (1.76 m)	6'-0" (1.829 m)	12'-0 1/2" (3.66 m)	12'-4 3/4" (3.77 m)	5 1/4 (140)	1 1/2 (40)	45°	16.7 (12.8)	103 (86)
50°	42 (1050)	4'-1" (1.25 m)	26 (660)	4'-10 1/2" (1.49 m)	6'-7 1/4" (2.014 m)	20'-2" (6.15 m)	11'-11 1/4" (3.64 m)	4'-4 1/4" (1.33 m)	4'-3" (1.295 m)	9'-10 1/2" (3.01 m)	10'-3 1/2" (3.14 m)	5 1/2 (140)	1 1/2 (40)	40°	11.0 (8.4)	71 (59)
	48 (1200)	4'-6" (1.35 m)	29 (740)	5'-5" (1.64 m)	7'-6 1/4" (2.291 m)	22'-4 1/2" (6.75 m)	13'-2" (3.95 m)	4'-9 1/2" (1.44 m)	4'-10" (1.473 m)	10'-11 3/4" (3.31 m)	11'-4 3/4" (3.44 m)	5 1/2 (140)	1 1/2 (40)	40°	13.3 (10.2)	82 (69)
	54 (1350)	4'-11 1/2" (1.56 m)	32 (810)	5'-11 1/2" (1.85 m)	8'-5" (2.568 m)	24'-7" (7.68 m)	14'-4 1/2" (4.56 m)	5'-2 3/4" (1.66 m)	5'-5" (1.651 m)	12'-1" (3.78 m)	12'-6" (3.9 m)	5 1/2 (140)	1 1/2 (40)	40°	15.8 (12.1)	102 (85)
	60 (1500)	5'-4" (1.62 m)	35 (890)	6'-6" (1.97 m)	9'-4" (2.845 m)	26'-9 1/4" (8.15 m)	15'-7 1/4" (4.72 m)	5'-8" (1.73 m)	6'-0" (1.829 m)	13'-2 1/4" (4.02 m)	13'-7" (4.13 m)	5 1/2 (140)	1 1/2 (40)	40°	18.5 (14.1)	112 (94)
55°	42 (1050)	4'-1" (1.25 m)	26 (660)	4'-10 1/2" (1.49 m)	7'-5" (2.257 m)	22'-5 3/4" (6.85 m)	13'-7" (4.14 m)	4'-3 1/2" (1.31 m)	4'-3" (1.295 m)	11'-0 1/4" (3.36 m)	11'-5 1/2" (3.49 m)	5 3/4 (150)	1 1/4 (30)	35°	12.3 (9.4)	79 (66)
	48 (1200)	4'-6" (1.35 m)	29 (740)	5'-5" (1.64 m)	8'-5" (2.568 m)	24'-11 1/2" (7.53 m)	14'-11 1/2" (4.49 m)	4'-8 1/2" (1.42 m)	4'-10" (1.473 m)	12'-3" (3.7 m)	12'-8 1/2" (3.83 m)	5 3/4 (150)	1 1/4 (30)	35°	14.9 (11.4)	92 (77)
	54 (1350)	4'-11 1/2" (1.56 m)	32 (810)	5'-11 1/2" (1.85 m)	9'-5 1/4" (2.878 m)	27'-5" (8.57 m)	16'-4 1/4" (5.19 m)	5'-1 3/4" (1.64 m)	5'-5" (1.651 m)	13'-6" (4.22 m)	13'-11" (4.35 m)	5 3/4 (150)	1 1/4 (30)	35°	17.7 (13.5)	113 (95)
	60 (1500)	5'-4" (1.62 m)	35 (890)	6'-6" (1.97 m)	10'-5 1/2" (3.188 m)	29'-10 3/4" (9.09 m)	17'-8 3/4" (5.39 m)	5'-7" (1.7 m)	6'-0" (1.829 m)	14'-8 3/4" (4.48 m)	15'-2" (4.61 m)	5 3/4 (150)	1 1/4 (30)	35°	20.8 (15.9)	125 (104)
60°	42 (1050)	4'-1" (1.25 m)	26 (660)	4'-10 1/2" (1.49 m)	8'-6" (2.59 m)	25'-7 3/4" (7.82 m)	15'-9 1/4" (4.81 m)	4'-2 3/4" (1.29 m)	4'-3" (1.295 m)	12'-7" (3.84 m)	13'-0 3/4" (3.98 m)	6 1/4 (160)	1 (30)	30°	14.1 (10.8)	89 (75)
	48 (1200)	4'-6" (1.35 m)	29 (740)	5'-5" (1.64 m)	9'-8" (2.946 m)	28'-5 3/4" (8.59 m)	17'-4 3/4" (5.22 m)	4'-8" (1.4 m)	4'-10" (1.473 m)	14'-0" (4.22 m)	14'-5 3/4" (4.37 m)	6 1/4 (160)	1 (30)	30°	17.0 (13.0)	104 (87)
	54 (1350)	4'-11 1/2" (1.56 m)	32 (810)	5'-11 1/2" (1.85 m)	10'-10" (3.302 m)	31'-3 3/4" (9.79 m)	19'-0" (6.03 m)	5'-1" (1.62 m)	5'-5" (1.651 m)	15'-5" (4.82 m)	15'-10 3/4" (4.97 m)	6 1/4 (160)	1 (30)	30°	20.3 (15.5)	129 (108)
	60 (1500)	5'-4" (1.62 m)	35 (890)	6'-6" (1.97 m)	12'-0" (3.658 m)	34'-1 3/4" (10.39 m)	20'-7 1/4" (6.26 m)	5'-6 1/4" (1.68 m)	6'-0" (1.829 m)	16'-10" (5.12 m)	17'-3 3/4" (5.27 m)	6 1/4 (160)	1 (30)	30°	23.8 (18.2)	142 (119)

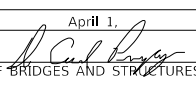
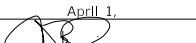
 Illinois Department of Transportation
 APPROVED April 1, 2016

 ENGINEER OF BRIDGES AND STRUCTURES
 APPROVED April 1, 2016

 ENGINEER OF DESIGN AND ENVIRONMENT

ISSUED 1-1-97

**REINFORCED CONCRETE END SECTIONS
 FOR PIPE CULVERTS
 42" (1050 mm) THRU 60" (1500 mm) DIA.
 SKEWED WITH ROADWAY**
 (Sheet 3 of 5)

STANDARD 542206-04

WINGS FOR 1:2 SLOPE

Skew Angle	Nominal Pipe Dia.	Dimensions for Concrete													Concrete 2 End Secs. cu. yd. (m ³)	Welded Wire Reinforcement 2 End Secs. sq. yd. (m ²)
		A	B	C	D	E	F	G	H	J	K	M	N	α		
5°	42 (1050)	5'-5"	26 (660)	4'-10½"	4'-3¼"	16'-1"	8'-0¼"	7'-4½"	4'-3"	8'-0¼"	8'-0¼"	3½	3	85°	8.0 (6.1)	61 (51)
	48 (1200)	6'-0"	29 (740)	5'-5"	4'-10¼"	17'-10"	8'-10½"	8'-1¾"	1.473 m (4'-10")	8'-10¾"	8'-11¼"	3½	3	85°	9.6 (7.3)	71 (59)
	54 (1350)	6'-7"	32 (810)	5'-11½"	5'-5¼"	19'-7"	9'-9"	8'-11¼"	1.651 m (5'-5")	9'-9¼"	9'-9¾"	3½	3	85°	11.3 (8.6)	88 (74)
	60 (1500)	7'-2"	35 (890)	6'-6"	6'-0¼"	21'-4¼"	10'-7¼"	9'-8¾"	1.829 m (6'-0")	10'-8"	10'-8¼"	3½	3	85°	13.2 (10.1)	96 (80)
10°	42 (1050)	5'-5"	26 (660)	4'-10½"	4'-3¾"	16'-3"	8'-5"	7'-0¾"	1.295 m (4'-3")	8'-1"	8'-2"	3¾	3	80°	8.3 (6.3)	62 (52)
	48 (1200)	6'-0"	29 (740)	5'-5"	4'-11"	18'-0½"	9'-4"	7'-10"	1.473 m (4'-10")	8'-11¼"	9'-0¾"	3¾	3	80°	9.9 (7.6)	72 (60)
	54 (1350)	6'-7"	32 (810)	5'-11½"	5'-6"	19'-9¾"	10'-3"	8'-7½"	1.651 m (5'-5")	9'-10½"	9'-11¼"	3¾	3	80°	11.7 (8.9)	90 (75)
	60 (1500)	7'-2"	35 (890)	6'-6"	6'-1"	21'-7"	11'-1¾"	9'-4½"	1.829 m (6'-0")	10'-9"	10'-10"	3¾	3	80°	13.7 (10.5)	98 (82)
15°	42 (1050)	5'-5"	26 (660)	4'-10½"	4'-4¾"	16'-6½"	8'-10¾"	6'-10"	1.295 m (4'-3")	8'-2½"	8'-4"	4	2¾	75°	8.6 (6.6)	64 (53)
	48 (1200)	6'-0"	29 (740)	5'-5"	5'-0"	18'-4½"	9'-10¼"	7'-6¾"	1.473 m (4'-10")	9'-1½"	9'-3"	4	2¾	75°	10.4 (8.0)	74 (62)
	54 (1350)	6'-7"	32 (810)	5'-11½"	5'-7¼"	20'-2"	10'-9¾"	8'-3½"	1.651 m (5'-5")	10'-0¼"	10'-1¾"	4	2¾	75°	12.3 (9.4)	92 (77)
	60 (1500)	7'-2"	35 (890)	6'-6"	6'-2½"	21'-11¾"	11'-9¼"	9'-0½"	1.829 m (6'-0")	10'-11¼"	11'-0½"	4	2¾	75°	14.3 (10.9)	100 (84)
20°	42 (1050)	5'-5"	26 (660)	4'-10½"	4'-6½"	16'-11¾"	9'-5½"	6'-7¼"	1.295 m (4'-3")	8'-5"	8'-6¾"	4¼	2½	70°	9.0 (6.9)	66 (55)
	48 (1200)	6'-0"	29 (740)	5'-5"	5'-1¾"	18'-10"	10'-5½"	7'-4"	1.473 m (4'-10")	9'-4"	9'-6"	4¼	2½	70°	10.9 (8.3)	76 (64)
	54 (1350)	6'-7"	32 (810)	5'-11½"	5'-9¼"	20'-8½"	11'-5¾"	8'-0½"	1.651 m (5'-5")	10'-3¼"	10'-5¼"	4¼	2½	70°	12.9 (9.9)	94 (79)
	60 (1500)	7'-2"	35 (890)	6'-6"	6'-4½"	22'-6¾"	12'-6"	8'-9"	1.829 m (6'-0")	11'-2½"	11'-4¼"	4¼	2½	70°	15.1 (11.5)	103 (86)
25°	42 (1050)	5'-5"	26 (660)	4'-10½"	4'-8¾"	17'-6¾"	10'-1"	6'-5"	1.295 m (4'-3")	8'-8½"	8'-10½"	4½	2¼	65°	9.5 (7.3)	65 (55)
	48 (1200)	6'-0"	29 (740)	5'-5"	5'-4"	19'-6"	11'-2"	7'-1¼"	1.473 m (4'-10")	9'-7¾"	9'-10¼"	4½	2¼	65°	11.5 (8.8)	79 (66)
	54 (1350)	6'-7"	32 (810)	5'-11½"	5'-11¾"	21'-5"	12'-3"	7'-9¾"	1.651 m (5'-5")	10'-7¼"	10'-9¾"	4½	2¼	65°	13.6 (10.4)	98 (82)
	60 (1500)	7'-2"	35 (890)	6'-6"	6'-7½"	23'-4¼"	13'-4"	8'-6"	1.829 m (6'-0")	11'-7"	11'-9¼"	4½	2¼	65°	15.9 (12.2)	107 (90)
30°	42 (1050)	5'-5"	26 (660)	4'-10½"	4'-11"	18'-4"	10'-10"	6'-3"	1.295 m (4'-3")	9'-0½"	9'-3½"	4½	2¼	60°	10.1 (7.7)	71 (59)
	48 (1200)	6'-0"	29 (740)	5'-5"	5'-7"	20'-4¼"	12'-0"	6'-11¼"	1.473 m (4'-10")	10'-0¾"	10'-3½"	4½	2¼	60°	12.2 (9.3)	82 (69)
	54 (1350)	6'-7"	32 (810)	5'-11½"	6'-3"	22'-4½"	13'-2"	7'-7¼"	1.651 m (5'-5")	11'-0¾"	11'-3¾"	4½	2¼	60°	14.4 (11.0)	102 (86)
	60 (1500)	7'-2"	35 (890)	6'-6"	6'-11¼"	24'-4¾"	14'-4"	8'-3¾"	1.829 m (6'-0")	12'-1"	12'-3¾"	4½	2¼	60°	16.9 (12.9)	112 (93)

Illinois Department of Transportation

APPROVED April 1, 2016

ENGINEER OF BRIDGES AND STRUCTURES

APPROVED April 1, 2016

ENGINEER OF DESIGN AND ENVIRONMENT

ISSUED 1-1-97

**REINFORCED CONCRETE END SECTIONS
FOR PIPE CULVERTS
42" (1050 mm) THRU 60" (1500 mm) DIA.
SKEWED WITH ROADWAY**

(Sheet 4 of 5)

STANDARD 542206-04

WINGS FOR 1:1 1/2 SLOPE

Skew Angle	Nominal Pipe Dia.	Dimensions for Concrete														Concrete 2 End Secs. cu. yd. (m ³)	Welded Wire Reinforcement 2 End Secs. sq. yd. (m ²)
		A	B	C	D	E	F	G	H	J	K	M	N	α			
35°	42 (1050)	5'-5"	26 (660)	4'-10 1/2"	5'-2 1/4"	19'-3 3/4"	11'-8 3/4"	6'-1 1/4"	4'-3"	9'-6 1/4"	9'-9 1/2"	4 3/4	2 (50)	55°	10.8 (8.3)	75 (63)	
	48 (1200)	6'-0"	29 (740)	5'-5"	5'-10 3/4"	21'-5 1/2"	13'-0"	6'-9 1/4"	4'-10"	10'-7"	10'-10 1/2"	4 3/4	2 (50)	55°	13.0 (9.9)	87 (73)	
	54 (1350)	6'-7"	32 (810)	5'-11 1/2"	6'-7 1/4"	23'-7"	14'-3"	7'-5"	5'-5"	11'-7 3/4"	11'-11 1/4"	4 3/4	2 (50)	55°	15.4 (11.8)	108 (90)	
	60 (1500)	7'-2"	35 (890)	6'-6"	7'-4"	25'-8 3/4"	15'-6 1/4"	8'-1"	6'-0"	12'-8 3/4"	13'-0"	4 3/4	2 (50)	55°	18.1 (13.8)	118 (99)	
40°	42 (1050)	5'-5"	26 (660)	4'-10 1/2"	5'-6 1/2"	20'-7"	12'-9 3/4"	5'-11 3/4"	4'-3"	10'-1 1/2"	10'-5 1/2"	5 1 3/4	1 3/4 (50)	50°	11.6 (8.9)	80 (67)	
	48 (1200)	6'-0"	29 (740)	5'-5"	6'-3 3/4"	22'-10 1/4"	14'-2 1/4"	6'-7 1/2"	4'-10"	11'-3 1/4"	11'-7"	5 1 3/4	1 3/4 (50)	50°	14.0 (10.7)	93 (77)	
	54 (1350)	6'-7"	32 (810)	5'-11 1/2"	7'-0 3/4"	25'-1 3/4"	15'-7"	7'-3 1/2"	5'-5"	12'-5"	12'-8 3/4"	5 1 3/4	1 3/4 (50)	50°	16.7 (12.8)	115 (96)	
	60 (1500)	7'-2"	35 (890)	6'-6"	7'-10"	27'-5 1/4"	16'-11 1/2"	7'-11"	6'-0"	13'-6 3/4"	13'-10 1/2"	5 1 3/4	1 3/4 (50)	50°	19.5 (14.9)	126 (105)	
45°	42 (1050)	5'-5"	26 (660)	4'-10 1/2"	6'-0"	22'-2 1/2"	14'-1 3/4"	5'-10 1/4"	4'-3"	10'-11"	11'-3 1/2"	5 1/4	1 1/2 (40)	45°	12.6 (9.6)	86 (72)	
	48 (1200)	6'-0"	29 (740)	5'-5"	6'-10"	24'-8 1/4"	15'-8 1/4"	6'-6"	4'-10"	12'-2"	12'-6 1/4"	5 1/4	1 1/2 (40)	45°	15.2 (12.0)	100 (83)	
	54 (1350)	6'-7"	32 (810)	5'-11 1/2"	7'-8"	27'-1 3/4"	17'-2 1/2"	7'-1 1/2"	5'-5"	13'-4 3/4"	13'-9"	5 1/4	1 1/2 (40)	45°	18.2 (13.9)	124 (104)	
	60 (1500)	7'-2"	35 (890)	6'-6"	8'-5 3/4"	29'-7 1/2"	18'-8 3/4"	7'-9"	6'-0"	14'-7 1/2"	15'-0"	5 1/4	1 1/2 (40)	45°	21.3 (16.3)	136 (114)	
50°	42 (1050)	5'-5"	26 (660)	4'-10 1/2"	6'-7 1/4"	24'-3 3/4"	15'-10"	5'-9 1/4"	4'-3"	11'-11 1/2"	12'-4 1/4"	5 1/2	1 1/2 (40)	40°	13.9 (10.6)	94 (78)	
	48 (1200)	6'-0"	29 (740)	5'-5"	7'-6 1/4"	27'-0 1/2"	17'-6 1/2"	6'-4 1/2"	4'-10"	13'-3 3/4"	13'-8 3/4"	5 1/2	1 1/2 (40)	40°	16.8 (12.8)	109 (91)	
	54 (1350)	6'-7"	32 (810)	5'-11 1/2"	8'-5"	29'-9 1/4"	19'-3"	7'-0"	5'-5"	14'-8 1/4"	15'-1"	5 1/2	1 1/2 (40)	40°	20.0 (15.3)	135 (113)	
	60 (1500)	7'-2"	35 (890)	6'-6"	9'-4"	32'-5 3/4"	20'-11 1/2"	7'-7 1/2"	6'-0"	16'-0 1/2"	16'-5 1/4"	5 1/2	1 1/2 (40)	40°	23.5 (18.0)	148 (124)	
55°	42 (1050)	5'-5"	26 (660)	4'-10 1/2"	7'-5"	27'-1 1/2"	18'-0 1/4"	5'-8 1/4"	4'-3"	13'-4 1/4"	13'-9 1/4"	5 3/4	1 1/4 (30)	35°	15.5 (11.9)	104 (87)	
	48 (1200)	6'-0"	29 (740)	5'-5"	8'-5"	30'-2 1/4"	19'-11 1/2"	6'-3 1/2"	4'-10"	14'-10 1/2"	15'-3 3/4"	5 3/4	1 1/4 (30)	35°	18.8 (14.4)	121 (101)	
	54 (1350)	6'-7"	32 (810)	5'-11 1/2"	9'-5 1/4"	33'-2 3/4"	21'-10 3/4"	6'-10 3/4"	5'-5"	16'-4 3/4"	16'-10"	5 3/4	1 1/4 (30)	35°	22.4 (17.1)	150 (125)	
	60 (1500)	7'-2"	35 (890)	6'-6"	10'-5 1/2"	36'-3 1/2"	23'-10"	7'-6 1/4"	6'-0"	17'-11 1/4"	18'-4 1/4"	5 3/4	1 1/4 (30)	35°	26.4 (20.2)	165 (138)	
60°	42 (1050)	5'-5"	26 (660)	4'-10 1/2"	8'-6"	30'-11 3/4"	20'-11 1/4"	5'-7 1/4"	4'-3"	15'-3"	15'-8 3/4"	6 1/4	1 (30)	30°	17.7 (13.5)	118 (98)	
	48 (1200)	6'-0"	29 (740)	5'-5"	9'-8"	34'-5 3/4"	23'-2 1/4"	6'-2 1/2"	4'-10"	17'-0"	17'-5 3/4"	6 1/4	1 (30)	30°	21.5 (16.4)	137 (115)	
	54 (1350)	6'-7"	32 (810)	5'-11 1/2"	10'-10"	37'-11 3/4"	25'-5 1/4"	6'-9 3/4"	5'-5"	18'-9"	19'-2 3/4"	6 1/4	1 (30)	30°	25.7 (19.6)	170 (142)	
	60 (1500)	7'-2"	35 (890)	6'-6"	12'-0"	41'-5 3/4"	27'-8 1/4"	7'-5"	6'-0"	20'-6"	20'-11 3/4"	6 1/4	1 (30)	30°	30.2 (23.1)	187 (157)	



 Illinois Department of Transportation
 APPROVED April 1, 2016
[Signature]
 ENGINEER OF BRIDGES AND STRUCTURES
 APPROVED April 1, 2016
[Signature]
 ENGINEER OF DESIGN AND ENVIRONMENT

ISSUED 1-1-97

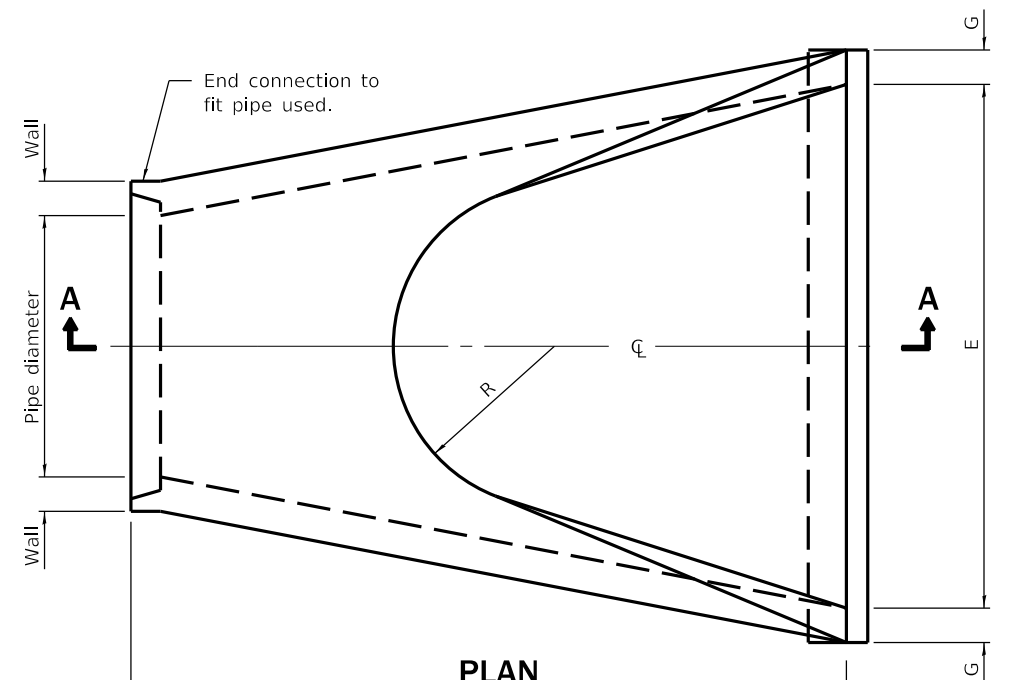
**REINFORCED CONCRETE END SECTIONS
 FOR PIPE CULVERTS
 42" (1050 mm) THRU 60" (1500 mm) DIA.
 SKEWED WITH ROADWAY**
 (Sheet 5 of 5)
STANDARD 542206-04

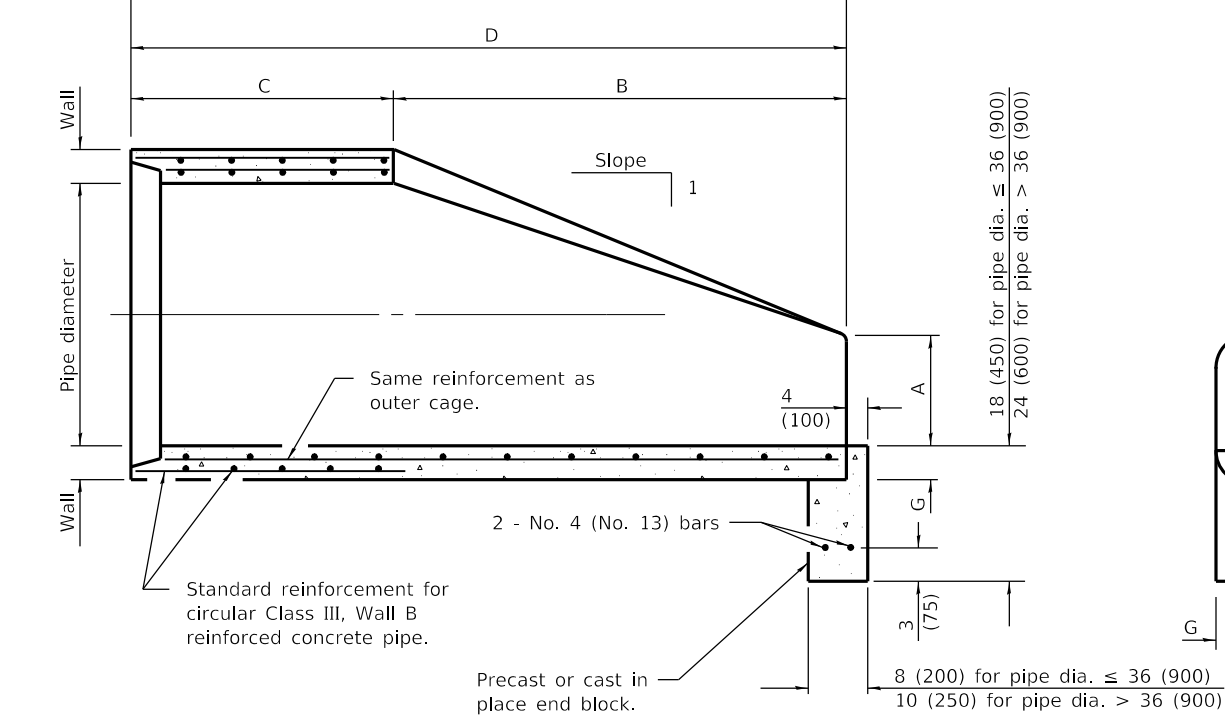

PLAN



SECTION A-A

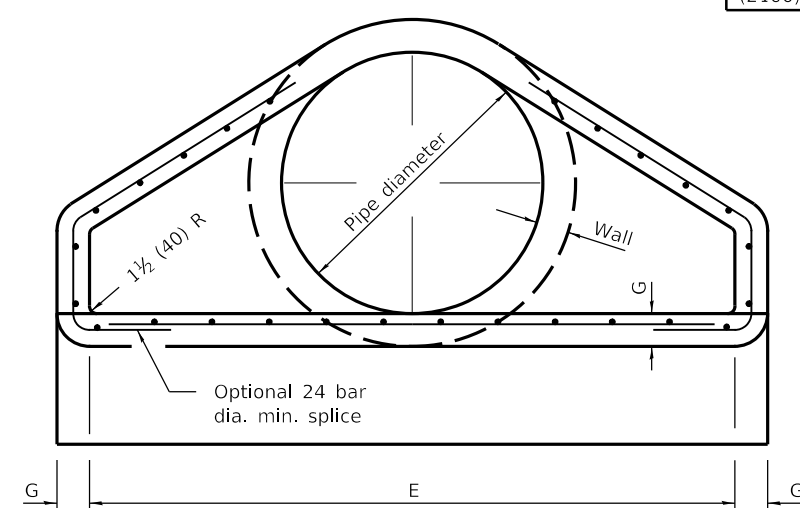

END VIEW

PIPE DIA.	APPROX. QTY. lbs. (kg)	WALL	A	B	C	D	E	G	R	APPROX. SLOPE
12 (300)	530 (240)	2 (51)	4 (102)	24 (610)	4'-0 7/8" (1.241 m)	6'-0 7/8" (1.851 m)	24 (610)	2 (51)	9 (229)	1:2.4
15 (375)	740 (335)	2 1/4 (57)	6 (152)	27 (686)	3'-10" (1.168 m)	6'-1" (1.854 m)	30 (762)	2 1/4 (57)	11 (280)	1:2.4
18 (450)	990 (450)	2 1/2 (64)	9 (229)	27 (686)	3'-10" (1.168 m)	6'-1" (1.854 m)	36 (914)	2 1/2 (64)	12 (305)	1:2.4
21 (525)	1280 (580)	2 3/4 (70)	9 (229)	35 (889)	38 (965)	6'-1" (1.854 m)	3'-6" (1.067 m)	2 3/4 (70)	13 (330)	1:2.4
24 (600)	1520 (690)	3 (76)	9 1/2 (241)	30 (762)	3'-7 1/2" (1.105 m)	6'-1 1/2" (1.867 m)	4'-0" (1.219 m)	3 (76)	14 (356)	1:2.5
27 (675)	1930 (875)	3 1/4 (83)	10 1/2 (267)	4'-0" (1.219 m)	25 1/2 (648)	6'-1 1/2" (1.867 m)	4'-6" (1.372 m)	3 1/4 (83)	14 1/2 (368)	1:2.4
30 (750)	2190 (995)	3 1/2 (89)	12 (305)	4'-6" (1.375 m)	19 3/4 (502)	6'-1 3/4" (1.874 m)	5'-0" (1.524 m)	3 1/2 (89)	15 (381)	1:2.5
33 (825)	3200 (1450)	3 3/4 (95)	13 1/2 (343)	4'-10 1/2" (1.486 m)	39 1/4 (997)	8'-1 3/4" (2.483 m)	5'-6" (1.676 m)	3 3/4 (95)	17 1/2 (445)	1:2.5
36 (900)	4100 (1860)	4 (102)	15 (381)	5'-3" (1.6 m)	34 3/4 (883)	8'-1 3/4" (2.483 m)	6'-0" (1.829 m)	4 (102)	20 (508)	1:2.5
42 (1050)	5380 (2440)	4 1/2 (114)	21 (533)	5'-3" (1.6 m)	35 (889)	8'-2" (2.489 m)	6'-6" (1.981 m)	4 1/2 (114)	22 (559)	1:2.5
48 (1200)	6550 (2970)	5 (127)	24 (610)	6'-0" (1.829 m)	26 (660)	8'-2" (2.489 m)	7'-0" (2.134 m)	5 (127)	22 (559)	1:2.5
54 (1350)	8240 (3740)	5 1/2 (140)	27 (686)	5'-5" (1.651 m)	35 (889)	8'-4" (2.54 m)	7'-6" (2.286 m)	5 1/2 (140)	24 (610)	1:2.0
60 (1500)	8730 (3960)	6 (152)	35 (889)	5'-0" (1.524 m)	39 (991)	8'-3" (2.515 m)	8'-0" (2.438 m)	5 (127)	*	1:1.9
66 (1650)	10710 (4860)	6 1/2 (165)	30 (762)	6'-0" (1.829 m)	27 (686)	8'-3" (2.515 m)	8'-6" (2.591 m)	5 1/2 (140)	*	1:1.7
72 (1800)	12520 (5680)	7 (178)	36 (914)	6'-6" (1.981 m)	21 (533)	8'-3" (2.514 m)	9'-0" (2.743 m)	6 (152)	*	1:1.8
78 (1950)	14770 (6700)	7 1/2 (191)	36 (914)	7'-6" (2.286 m)	21 (533)	9'-3" (2.819 m)	9'-6" (2.896 m)	6 1/2 (165)	*	1:1.8
84 (2100)	18160 (8240)	8 (203)	36 (914)	7'-6 1/2" (2.299 m)	21 (533)	9'-3 1/2" (2.832 m)	10'-0" (3.048 m)	6 1/2 (165)	*	1:1.6

* Radius as furnished by manufacturer

GENERAL NOTES

All slope ratios are expressed as units of vertical displacement to units of horizontal displacement (V:H).

All dimensions are in inches (millimeters) unless otherwise shown.

DATE	REVISIONS
1-1-11	Clarified ref. to pipe dia. on Section A-A. Changed 'inner' to 'outer' cage ref.
1-1-09	Switched units to English (metric).

PRECAST REINFORCED CONCRETE FLARED END SECTION

STANDARD 542301-03

Illinois Department of Transportation

APPROVED January 1, 2011
Ralph E. Anderson
 ENGINEER OF BRIDGES AND STRUCTURES

APPROVED January 1, 2011
Scott Schick
 ENGINEER OF DESIGN AND ENVIRONMENT

ISSUED 1-1-97

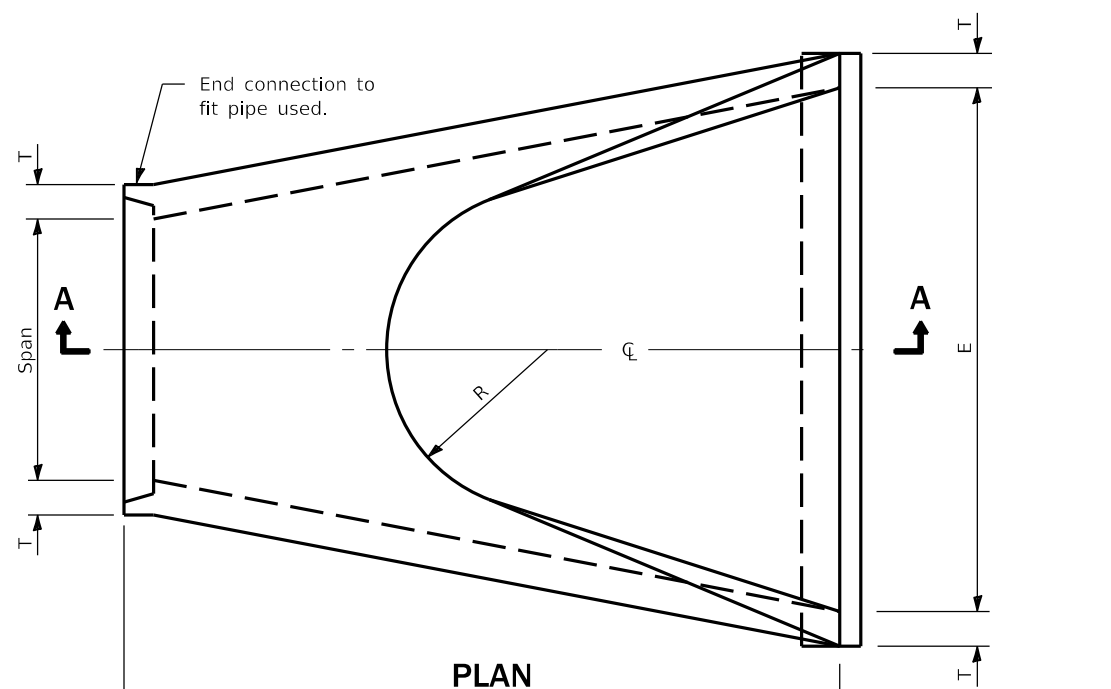

PLAN

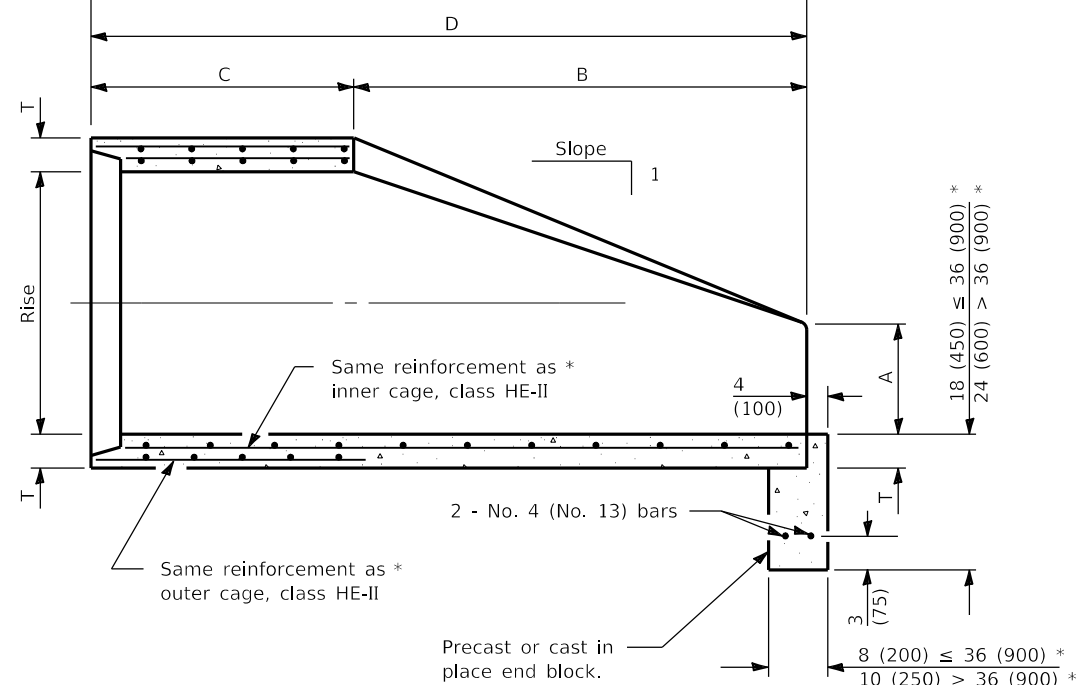

SECTION A-A

* Refers to the equivalent pipe diameter.

SPAN	RISE	EQUIV. DIA.	WALL T	A	B	C	D	E	H	R	R ₁	R ₂	APPROX. SLOPE
23 (584)	14 (356)	18 (450)	2 3/4 (70)	8 (203)	27 (686)	3'-9" (1.143 m)	6'-0" (1.829 m)	36 (914)	5 3/8 (137)	6 (152)	6 (152)	20 (508)	1:3.1
30 (762)	19 (483)	24 (600)	3 1/4 (83)	8 1/2 (216)	39 (991)	33 (838)	6'-0" (1.829 m)	4'-0" (1.219 m)	6 7/8 (175)	7 (178)	8 1/4 (210)	26 1/4 (667)	1:2.8
34 (864)	22 (559)	27 (675)	3 1/2 (89)	9 (229)	4'-0" (1.219 m)	24 (610)	6'-0" (1.829 m)	4'-6" (1.372 m)	7 3/4 (197)	8 (203)	9 1/4 (235)	29 1/4 (743)	1:2.9
38 (965)	24 (610)	30 (750)	3 1/2 (95)	9 1/2 (241)	4'-6" (1.372 m)	18 (475)	6'-0" (1.829 m)	5'-0" (1.524 m)	8 5/8 (219)	9 (229)	10 1/4 (260)	32 3/4 (832)	1:2.9
45 (1143)	29 (737)	36 (900)	4 1/2 (114)	11 1/4 (286)	5'-0" (1.524 m)	36 (914)	8'-0" (2.438 m)	6'-0" (1.829 m)	10 1/2 (267)	12 (305)	12 1/4 (311)	39 1/4 (997)	1:2.7
53 (1346)	34 (864)	42 (1050)	5 (127)	15 3/4 (400)	5'-0" (1.524 m)	36 (914)	8'-0" (2.438 m)	6'-6" (1.981 m)	12 1/2 (308)	13 (330)	14 1/2 (368)	3'-10" (1.168 m)	1:2.6
60 (1524)	38 (965)	48 (1200)	5 1/2 (140)	21 (533)	5'-0" (1.524 m)	36 (914)	8'-0" (2.438 m)	7'-0" (2.134 m)	13 1/2 (343)	14 (356)	16 1/2 (419)	4'-3 1/2" (1.308 m)	1:2.7
68 (1727)	43 (1092)	54 (1350)	6 (152)	26 (660)	5'-0" (1.524 m)	36 (914)	8'-0" (2.438 m)	7'-6" (2.286 m)	15 1/4 (387)	16 (406)	18 3/4 (476)	4'-10 1/2" (1.486 m)	1:2.6
76 (1930)	48 (1219)	60 (1500)	6 1/2 (165)	31 (787)	5'-0" (1.524 m)	36 (914)	8'-0" (2.438 m)	8'-0" (2.439 m)	17 (432)	18 (457)	20 3/4 (527)	5'-5" (1.651 m)	1:2.6

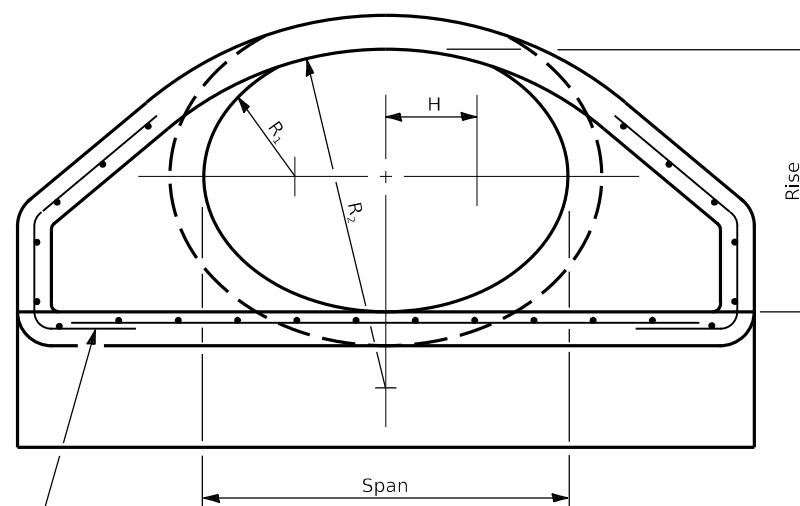

END VIEW

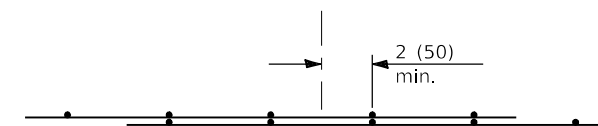

OPTIONAL WELDED WIRE REINFORCEMENT LAP

GENERAL NOTES

All slope ratios are expressed as units of vertical displacement to units of horizontal displacement (V:H).

All dimensions are in inches (millimeters) unless otherwise shown.

DATE	REVISIONS
4-1-16	Changed terminology to 'welded wire reinforcement'.
	Corrected min. lap dimension.
1-1-09	Switched units to English (metric).

PRECAST REINFORCED CONCRETE ELLIPTICAL FLARED END SECTION

STANDARD 542306-03

Illinois Department of Transportation

APPROVED April 1, 2016

ENGINEER OF BRIDGES AND STRUCTURES

APPROVED April 1, 2016

ENGINEER OF DESIGN AND ENVIRONMENT

ISSUED 1-1-97

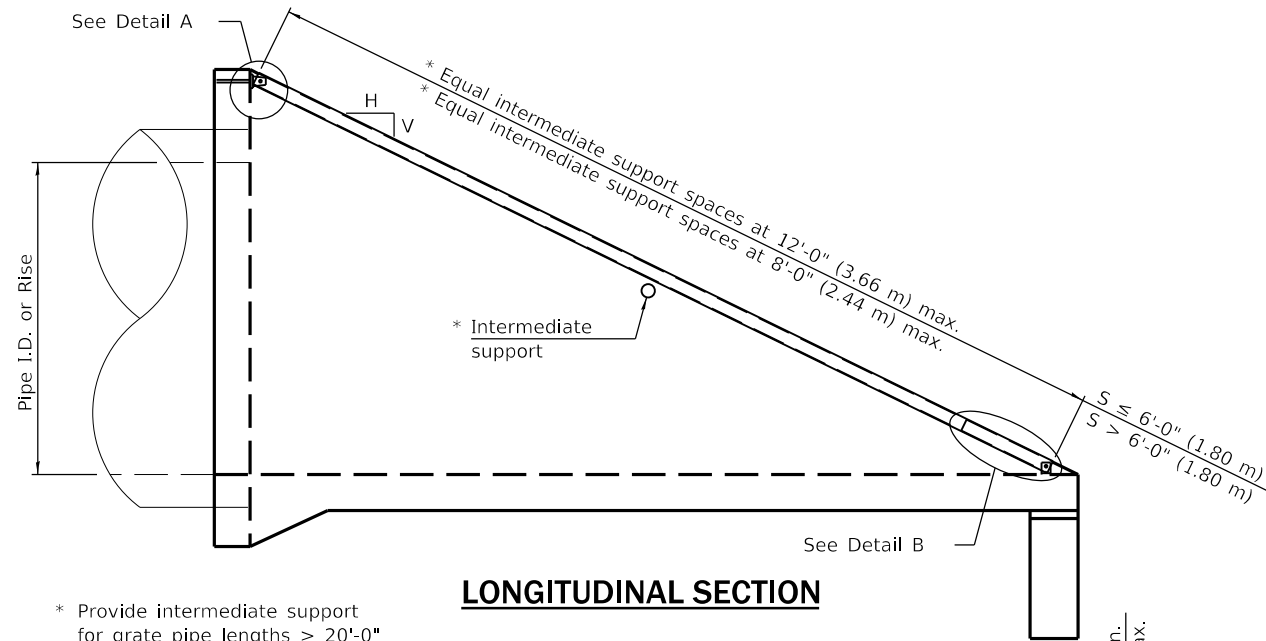

* Provide intermediate support for grate pipe lengths > 20'-0" (6.00 m).

LONGITUDINAL SECTION

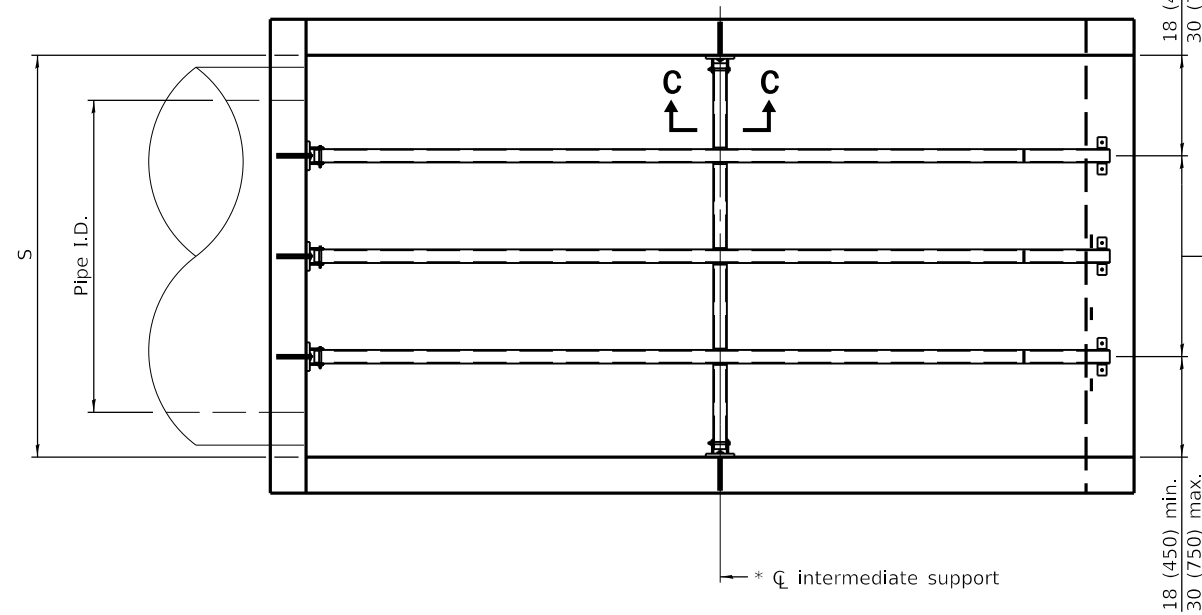

PLAN VIEW

Steel pipes at 18 (450) cts. min. 30 (750) cts. max.

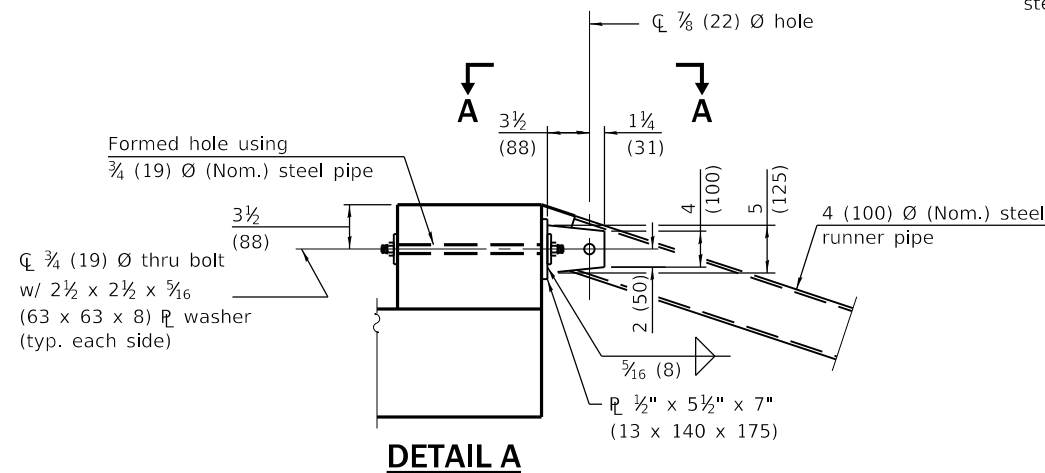

DETAIL A

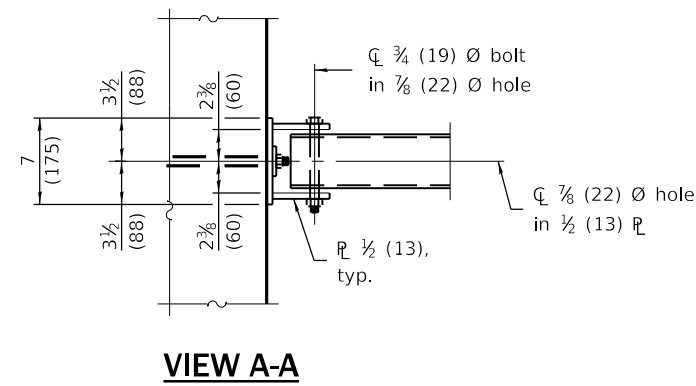

VIEW A-A

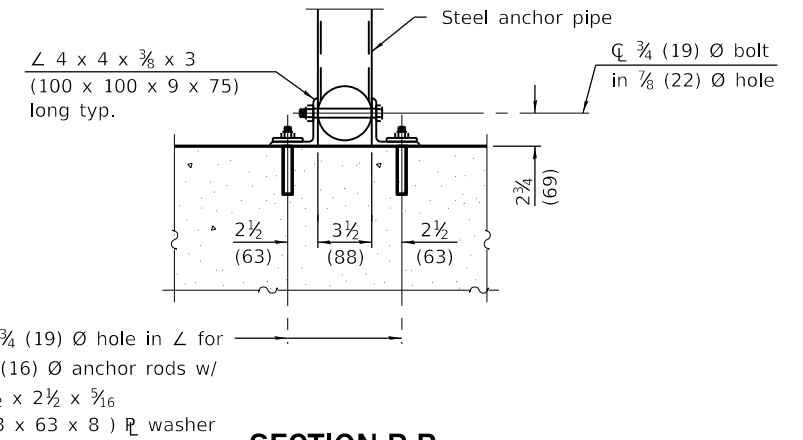

SECTION B-B

C 3/4 (19) Ø hole in L for 5/8 (16) Ø anchor rods w/ 2 1/2 x 2 1/2 x 3/16 (63 x 63 x 8) R washer

6 1/2 (165) for 1:3 slope **
7 (178) for 1:4 slope **
7 3/8 for 1:6 slope **

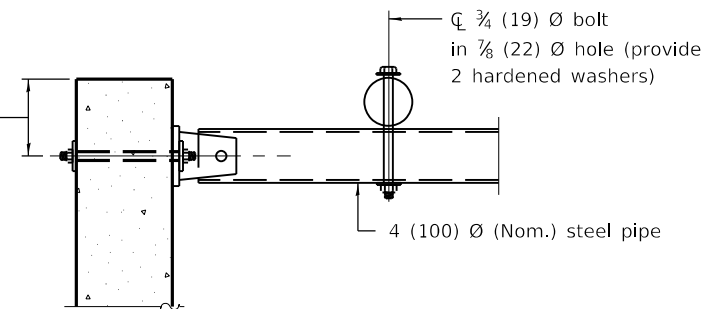

SECTION D-D

** Measured perpendicular to top of culvert wall. In addition, formed hole shall be located a minimum of 6 (150) measured horizontally from any vertical joints necessary for construction of the culvert end section.

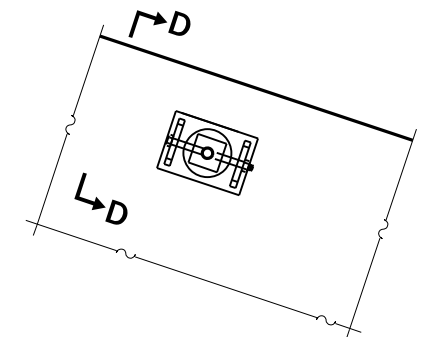

VIEW C-C

(See Detail A for dimensions and details not shown.)

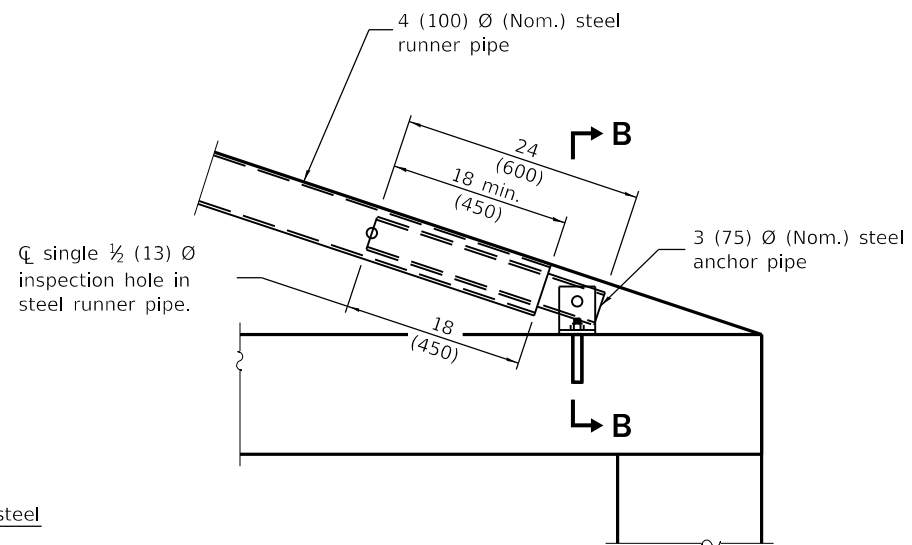

DETAIL B

GENERAL NOTES

This standard shall only be used on concrete end sections not skewed more than ± 15 degrees with roadway.

The minimum distance from the center of a hole to the free edge of a structural shape or plate shall be 1 1/2 (38) unless noted otherwise.

All dimensions are in inches (millimeters) unless otherwise shown.

DATE	REVISIONS
1-1-18	Corrected value in elliptical pipe table. Renamed standard.
4-1-16	Corrected typo.

TRAVERSABLE PIPE GRATE FOR CONCRETE END SECTIONS

(Sheet 1 of 2)

STANDARD 542311-07

Illinois Department of Transportation

APPROVED January 1, 2018

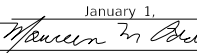
 ENGINEER OF BRIDGES AND STRUCTURES

APPROVED January 1, 2018

 ENGINEER OF DESIGN AND ENVIRONMENT

ISSUED 1-1-97

PIPE-GRATE SCHEDULE FOR PIPE CULVERT END SECTIONS

Pipe I.D.	Slope of End Section								
	1:3			1:4			1:6		
	Main Pipe No. / Length	Int. Support No. / Length	Total Length of Pipe	Main Pipe No. / Length	Int. support No. / Length	Total Length of Pipe	Main Pipe No. / Length	Int. Support No. / Length	Total Length of Pipe
27 (675)	1 @ 9'-8" 1 @ (2.95 m)	N/A	9'-8" (2.95 m)	1 @ 12'-11" 1 @ (3.94 m)	N/A	12'-11" (3.94 m)	1 @ 19'-7" 1 @ (5.97 m)	N/A	19'-7" (5.97 m)
30 (750)	1 @ 11'-4" 1 @ (3.43 m)	N/A	11'-4" (3.43 m)	1 @ 14'-10" 1 @ (4.52 m)	N/A	14'-10" (4.52 m)	1 @ 21'-10" 1 @ (6.65 m)	1 @ 3'-6" 1 @ (1.07 m)	25'-4" (7.72 m)
33 (825)	1 @ 12'-1" 1 @ (3.68 m)	N/A	12'-1" (3.68 m)	1 @ 15'-10" 1 @ (4.83 m)	N/A	15'-10" (4.83 m)	1 @ 23'-5" 1 @ (7.14 m)	1 @ 3'-7" 1 @ (1.09 m)	27'-0" (8.23 m)
36 (900)	1 @ 12'-10" 1 @ (3.91 m)	N/A	12'-10" (3.91 m)	1 @ 16'-10" 1 @ (5.13 m)	N/A	16'-10" (5.13 m)	1 @ 24'-11" 1 @ (7.59 m)	2 @ 3'-11" 2 @ (1.19 m)	32'-9" (9.97 m)
42 (1050)	2 @ 14'-9" 2 @ (4.50 m)	N/A	29'-6" (9.00 m)	2 @ 19'-3" 2 @ (5.87 m)	N/A	38'-6" (11.74 m)	2 @ 28'-6" 2 @ (8.69 m)	2 @ 4'-7" 2 @ (1.40 m)	66'-2" (20.18 m)
48 (1200)	2 @ 16'-4" 2 @ (4.98 m)	N/A	32'-8" (9.96 m)	2 @ 21'-4" 2 @ (6.50 m)	1 @ 5'-1" 1 @ (1.55 m)	47'-9" (14.55 m)	2 @ 31'-6" 2 @ (9.60 m)	2 @ 5'-1" 2 @ (1.55 m)	73'-2" (22.30 m)
54 (1350)	2 @ 18'-2" 2 @ (5.54 m)	N/A	36'-4" (11.08 m)	2 @ 23'-9" 2 @ (7.24 m)	2 @ 5'-9" 2 @ (1.75 m)	59'-0" (16.23 m)	2 @ 35'-1" 2 @ (10.69 m)	4 @ 5'-9" 4 @ (1.75 m)	93'-2" (28.38 m)
60 (1500)	2 @ 19'-9" 2 @ (6.02 m)	N/A	39'-6" (12.04 m)	2 @ 25'-10" 2 @ (7.87 m)	3 @ 6'-3" 3 @ (1.91 m)	70'-5" (21.47 m)	2 @ 38'-1" 2 @ (11.61 m)	4 @ 6'-3" 4 @ (1.91 m)	101'-2" (30.86 m)
66 (1650)	2 @ 21'-7" 2 @ (6.58 m)	2 @ 6'-11" 2 @ (2.11 m)	57'-0" (17.38 m)	2 @ 28'-2" 2 @ (8.59 m)	3 @ 6'-11" 3 @ (2.11 m)	77'-1" (23.51 m)	2 @ 41'-11" 2 @ (12.78 m)	5 @ 6'-11" 5 @ (2.11 m)	127'-5" (36.11 m)
72 (1800)	3 @ 23'-2" 3 @ (7.06 m)	2 @ 7'-5" 2 @ (2.26 m)	84'-4" (25.70 m)	3 @ 30'-3" 3 @ (9.22 m)	3 @ 7'-5" 3 @ (2.26 m)	113'-0" (34.44 m)	3 @ 44'-8" 3 @ (13.61 m)	5 @ 7'-5" 5 @ (2.26 m)	171'-1" (52.13 m)
78 (1950)	3 @ 25'-0" 3 @ (7.62 m)	3 @ 8'-1" 3 @ (2.46 m)	99'-3" (30.24 m)	3 @ 32'-8" 3 @ (9.96 m)	4 @ 8'-1" 4 @ (2.46 m)	130'-4" (39.72 m)	3 @ 48'-3" 3 @ (14.71 m)	6 @ 8'-1" 6 @ (2.46 m)	193'-3" (58.89 m)
84 (2100)	3 @ 26'-7" 3 @ (8.10 m)	3 @ 8'-7" 3 @ (2.62 m)	105'-6" (32.16 m)	3 @ 34'-9" 3 @ (10.59 m)	4 @ 8'-7" 4 @ (2.62 m)	138'-7" (42.25 m)	3 @ 51'-3" 3 @ (15.62 m)	6 @ 8'-7" 6 @ (2.62 m)	206'-3" (62.58 m)

PIPE-GRATE SCHEDULE FOR ELLIPTICAL PIPE CULVERT END SECTIONS

Pipe I.D. (Equiv. Round)	Slope of End Section								
	1:3			1:4			1:6		
	Main Pipe No. / Length	Int. Support No. / Length	Total Length of Pipe	Main Pipe No. / Length	Int. Support No. / Length	Total Length of Pipe	Main Pipe No. / Length	Int. Support No. / Length	Total Length of Pipe
21 (525)	1 @ 8'-2" 1 @ (2.49 m)	N/A	8'-2" (2.49 m)	1 @ 11'-2" 1 @ (3.40 m)	N/A	11'-2" (3.40 m)	1 @ 17'-5" 1 @ (5.31 m)	N/A	17'-5" (5.31 m)
24 (600)	1 @ 8'-2" 1 @ (2.49 m)	N/A	8'-2" (2.49 m)	1 @ 11'-2" 1 @ (3.40 m)	N/A	11'-2" (3.40 m)	1 @ 17'-5" 1 @ (5.31 m)	N/A	17'-5" (5.31 m)
27 (675)	1 @ 8'-11" 1 @ (2.72 m)	N/A	8'-11" (2.72 m)	1 @ 12'-2" 1 @ (3.71 m)	N/A	12'-2" (3.71 m)	1 @ 18'-11" 1 @ (5.77 m)	N/A	18'-11" (5.77 m)
30 (750)	1 @ 9'-5" 1 @ (2.87 m)	N/A	9'-5" (2.87 m)	1 @ 12'-11" 1 @ (3.94 m)	N/A	12'-11" (3.94 m)	1 @ 19'-11" 1 @ (6.07 m)	N/A	19'-11" (6.07 m)
36 (900)	2 @ 11'-0" 2 @ (3.35 m)	N/A	22'-0" (6.70 m)	2 @ 14'-11" 2 @ (4.55 m)	N/A	29'-10" (9.10 m)	2 @ 22'-11" 2 @ (6.99 m)	1 @ 4'-7" 1 @ (1.40 m)	50'-5" (15.38 m)
42 (1050)	2 @ 12'-4" 2 @ (3.76 m)	N/A	24'-8" (7.52 m)	2 @ 16'-8" 2 @ (5.08 m)	N/A	33'-4" (10.16 m)	2 @ 25'-6" 2 @ (7.77 m)	2 @ 5'-5" 2 @ (1.65 m)	61'-10" (18.84 m)
48 (1200)	2 @ 13'-8" 2 @ (4.17 m)	N/A	27'-4" (8.34 m)	2 @ 18'-5" 2 @ (5.61 m)	N/A	36'-10" (11.22 m)	2 @ 28'-0" 2 @ (8.53 m)	3 @ 6'-1" 3 @ (1.85 m)	74'-3" (22.61 m)
54 (1350)	2 @ 15'-0" 2 @ (4.75 m)	N/A	30'-0" (9.50 m)	2 @ 20'-1" 2 @ (6.12 m)	2 @ 6'-9" 2 @ (2.06 m)	53'-8" (16.36 m)	2 @ 30'-7" 2 @ (9.32 m)	3 @ 6'-9" 3 @ (2.06 m)	81'-5" (24.82 m)
60 (1500)	3 @ 16'-7" 3 @ (5.05 m)	N/A	49'-9" (15.15 m)	3 @ 22'-2" 3 @ (6.76 m)	2 @ 7'-7" 2 @ (2.31 m)	81'-8" (24.90 m)	3 @ 33'-7" 3 @ (10.24 m)	4 @ 7'-7" 4 @ (2.31 m)	131'-1" (39.96 m)
66 (1650)	3 @ 17'-11" 3 @ (5.46 m)	N/A	53'-9" (16.38 m)	3 @ 23'-11" 3 @ (7.29 m)	2 @ 8'-3" 2 @ (2.51 m)	88'-3" (26.89 m)	3 @ 36'-2" 3 @ (11.02 m)	4 @ 8'-3" 4 @ (2.51 m)	141'-6" (43.10 m)
72 (1800)	3 @ 19'-6" 3 @ (5.94 m)	N/A	58'-6" (17.82 m)	3 @ 25'-11" 3 @ (7.90 m)	3 @ 8'-11" 3 @ (2.72 m)	104'-6" (31.86 m)	3 @ 39'-2" 3 @ (11.94 m)	4 @ 8'-11" 4 @ (2.72 m)	153'-2" (46.70 m)

Illinois Department of Transportation

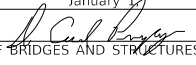
APPROVED January 1, 2018

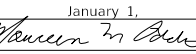
 ENGINEER OF BRIDGES AND STRUCTURES

APPROVED January 1, 2018

 ENGINEER OF DESIGN AND ENVIRONMENT

ISSUED 1-1-97

**TRAVERSABLE PIPE GRATE
FOR CONCRETE END
SECTIONS** (Sheet 2 of 2)

STANDARD 542311-07

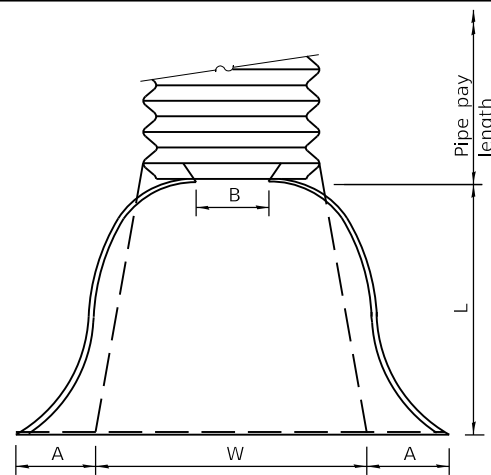
PIPE DIA.	THICKNESS	DIMENSIONS					SLOPE (Approx.) (V:H)	BODY
		A	B	H	L	W		
12 (300)	0.064 (1.63)	1± (25)	(max.) 6	1± (25)	1½± (38)	2± (50)	1:2½	1 Pc.
15 (375)	0.064 (1.63)	7	8	6	26	30	1:2½	1 Pc.
18 (450)	0.064 (1.63)	8	10	6	31	36	1:2½	1 Pc.
21 (525)	0.064 (1.63)	9	12	6	36	42	1:2½	1 Pc.
24 (600)	0.064 (1.63)	10	13	6	41	48	1:2½	1 Pc.
30 (750)	0.079 (2.01)	12	16	8	51	60	1:2½	1 Pc.
36 (900)	0.079 (2.01)	14	19	9	60	72	1:2½	2 Pc.
42 (1050)	0.109 (2.77)	16	22	11	69	84	1:2½	2 Pc.
48 (1200)	0.109 (2.77)	18	27	12	78	90	1:2¼	2 Pc.
54 (1350)	0.109 (2.77)	18	30	12	84	102	1:2	2 Pc.
60 (1500)	0.109 (2.77)	18	33	12	87	114	1:1¾	3 Pc.
66 (1650)	0.109 (2.77)	18	36	12	87	120	1:1½	3 Pc.
72 (1800)	0.109 (2.77)	18	39	12	87	126	1:1⅓	3 Pc.
78 (1950)	0.109 (2.77)	18	42	12	87	132	1:1¼	3 Pc.
84 (2250)	0.109 (2.77)	18	45	12	87	138	1:1⅓	3 Pc.



PLAN

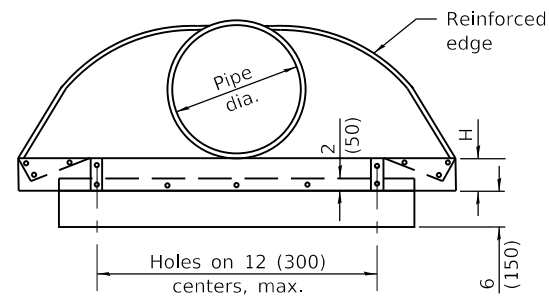

END VIEW

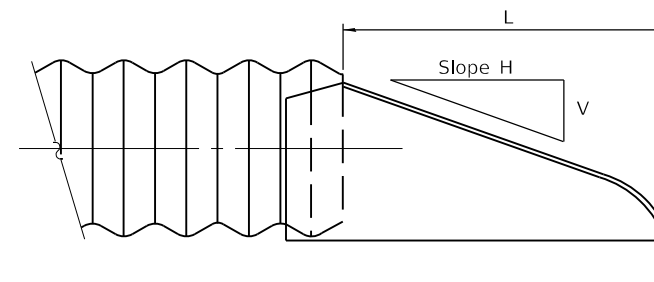

SIDE VIEW

END SECTION

NOTES

For 60 (1500) thru 84 (2250) sizes, reinforced edges shall be supplemented with stiffener angles. The angles shall be 2x2x¼(51x51x6.4) for 60 (1500) thru 72 (1800) diameter and 2½x2½x¼ (64x64x6.4) for 78 (1950) thru 84 (2250) diameter. The angles shall be attached by ⅝ (M10) rivets or bolts.

All slope ratios are expressed as units of vertical displacement to units of horizontal displacement (V:H).

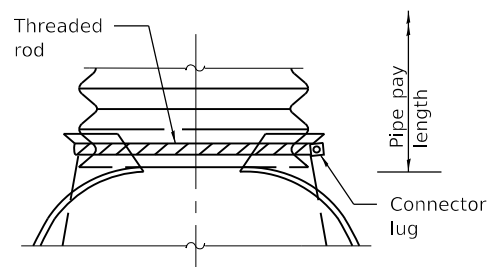

TYPE 1

For 12 (300) thru 24 (600) only (See Note 1)

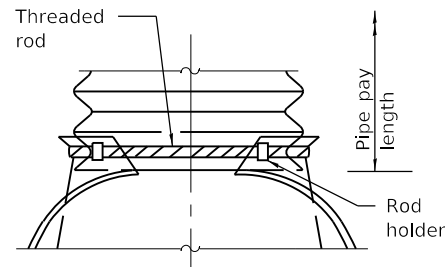

TYPE 2

For 30 (750) and 36 (900) only (See Note 1)

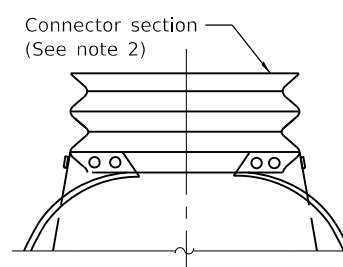

TYPE 3

(See Note 2)

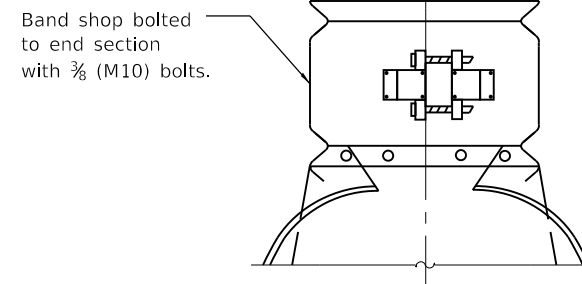

TYPE 4

(See Note 3)

NOTES

- Types 1 and 2 for pipes with annular ends only.
- Type 3 connection may be used for all pipe sizes and includes 12 (300) of the pipe length. The connector section shall be attached to the end section by rivets or bolts and shall be the same metal thickness as the end section. Stub shall be either 2⅔ (68) pitch x ½ (13) depth or 3 (75) pitch x 1 (25) depth annular corrugated pipe.
- Type 4 connection can be used for all pipe sizes. Coupler shall be 2⅔ x ½ (68x13) dimple, hugger, or annular band of 3x1 (75x25). The dimple, hugger, or annular band may be used with corrugated metal pipes having annular ends. For corrugated metal pipes having helical ends, only the dimple band will be allowed.

All dimensions are in inches (millimeters) unless otherwise shown.

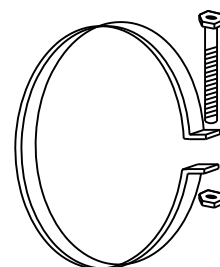

ALTERNATE STRAP CONNECTOR

(For Type 1 only)

1 (25) wide, 0.109 (2.77) thick strap with standard ½x6 (M12x150) band bolt and nut.

CONNECTIONS OF END SECTIONS

DATE	REVISIONS
1-1-21	Revised THICKNESS values in table.
1-1-18	Renamed standard.

METAL FLARED END SECTION FOR PIPE CULVERTS

STANDARD 542401-04

Illinois Department of Transportation

PASSED January 1, 2021

 ENGINEER OF POLICY AND PROCEDURES

APPROVED January 1, 2021

 ENGINEER OF DESIGN AND ENVIRONMENT

ISSUED 1-1-97

PIPE ARCH DIMENSIONS		THICKNESS	DIMENSIONS					SLOPE (Approx.) (V:H)	BODY
SPAN	RISE		A	B	H	L	W		
17 (432)	13 (330)	0.064 (1.63)	7 (180)	9 (230)	6 (150)	19 (485)	30 (760)	1:2½	1 Pc.
21 (533)	15 (381)	0.064 (1.63)	7 (180)	10 (255)	6 (150)	23 (585)	36 (915)	1:2½	1 Pc.
24 (610)	18 (457)	0.064 (1.63)	8 (205)	12 (305)	6 (150)	28 (710)	42 (1,065 m)	1:2½	1 Pc.
28 (711)	20 (508)	0.064 (1.63)	9 (230)	14 (355)	6 (150)	32 (815)	48 (1,220 m)	1:2½	1 Pc.
35 (889)	24 (610)	0.079 (2.01)	10 (255)	16 (405)	6 (150)	39 (990)	60 (1,525 m)	1:2½	1 Pc.
42 (1067)	29 (737)	0.079 (2.01)	12 (305)	18 (460)	8 (205)	53 (1,170 m)	75 (1,905 m)	1:2½	1 Pc.
49 (1245)	33 (838)	0.109 (2.77)	13 (330)	21 (535)	9 (230)	46 (1,345 m)	85 (2,160 m)	1:2½	2 Pc.
57 (1448)	38 (965)	0.109 (2.77)	18 (460)	26 (660)	12 (305)	63 (1,600 m)	90 (2,285 m)	1:2½	2 Pc.
64 (1626)	43 (1092)	0.109 (2.77)	18 (460)	30 (760)	12 (305)	70 (1,780 m)	102 (2,590 m)	1:2¼	2 Pc.
71 (1803)	47 (1194)	0.109 (2.77)	18 (460)	33 (840)	12 (305)	77 (1,955 m)	114 (2,895 m)	1:2¼	3 Pc.
77 (1956)	52 (1321)	0.109 (2.77)	18 (460)	36 (915)	12 (305)	77 (1,955 m)	126 (3,200 m)	1:2	3 Pc.
83 (2108)	57 (1448)	0.109 (2.77)	18 (460)	39 (990)	12 (305)	77 (1,955 m)	138 (3,505 m)	1:2	3 Pc.

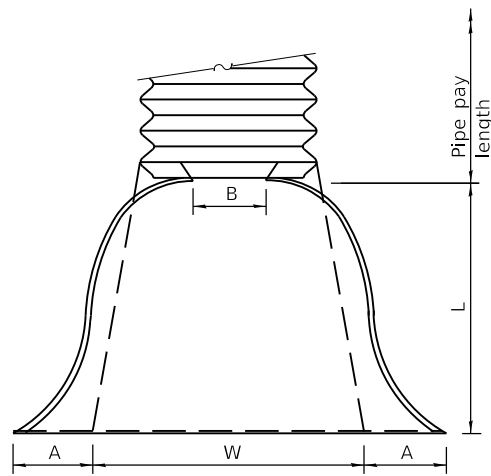

PLAN

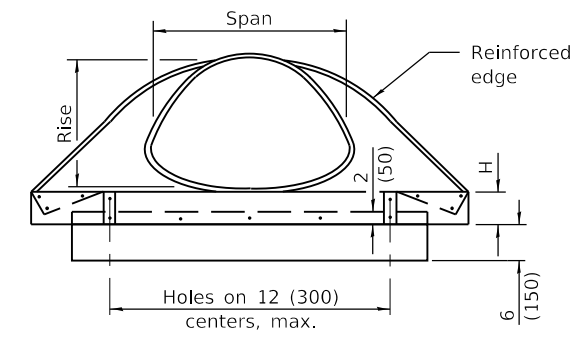

END VIEW

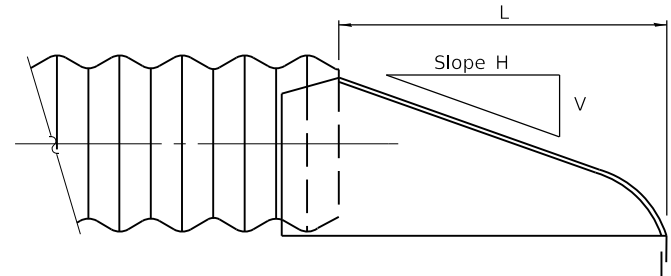

SIDE VIEW

END SECTION

NOTES

For the 77x52 (1956x1321) and 83x57 (2108x1448) sizes, reinforced edges shall be supplemented with 2x2x¼ (51x51x6.4) stiffener angles. The angles shall be attached by ⅜ (M10) rivets or bolts.

Angle reinforcement shall be placed under the center panel seams on the 77x52 (1956x1321) and 83x57 (2108x1448) sizes.

All slope ratios are expressed as units of vertical displacement to units of horizontal displacement (V:H).

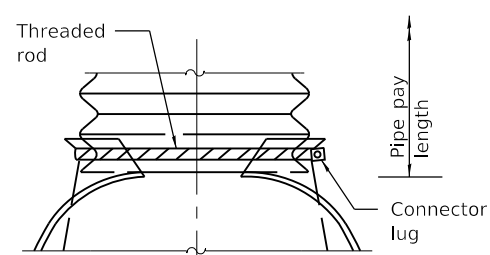

TYPE 1

For 17x13 (432x330) thru 28x20 (711x508) only (See Note 1)

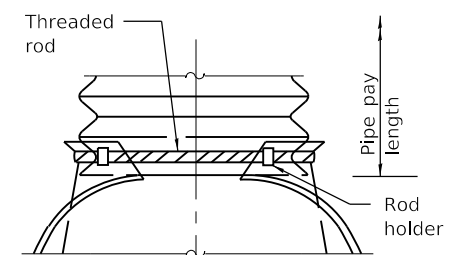

TYPE 2

For 17x13 (432x330) thru 57x38 (1448x965) only (See Note 1)

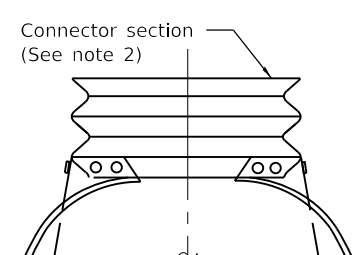

TYPE 3

(See Note 2)

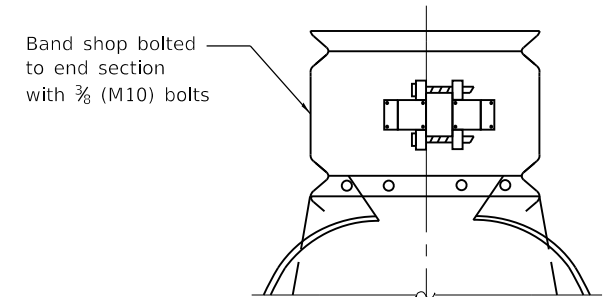

TYPE 4

(See Note 3)

NOTES

- Type 1 and 2 connection shall be used only with pipes with annular ends.
- Type 3 connection can be used with all pipe arch sizes and includes 12 (300) of the pipe length. The annular connector section shall be attached to the end section by rivets or bolts and shall be the same metal thickness as the end section. When coupling the type 3 end section to a pipe with helical ends, only the dimple type coupling band shall be used.
- Type 4 connection can be used with all pipe arch sizes. The end section band shall be either a dimple, hugger, or annular band and can be used with pipes having annular ends. For pipes having helical ends, only the dimple end section band will be allowed.

All dimensions are in inches (millimeters) unless otherwise shown.

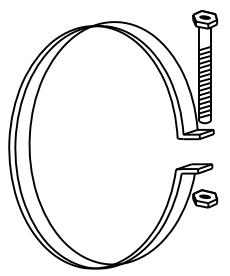

ALTERNATE STRAP CONNECTOR

(For Type 1 only)

1 (25) wide, 0.109 (2.77) thick strap with standard ½x6 (M12x150) band bolt and nut.

CONNECTIONS OF END SECTIONS

DATE	REVISIONS
1-1-21	Revised THICKNESS values in table.
1-1-18	Renamed standard.

METAL FLARED END SECTION FOR PIPE ARCHES

STANDARD 542406-04

Illinois Department of Transportation

PASSED January 1, 2021

 ENGINEER OF POLICY AND PROCEDURES

APPROVED January 1, 2021

 ENGINEER OF DESIGN AND ENVIRONMENT

ISSUED 1-1-97

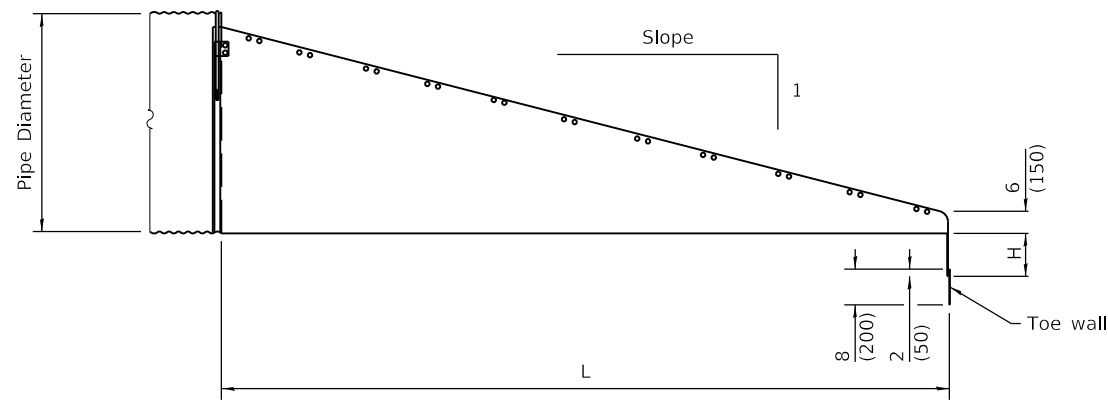

ELEVATION

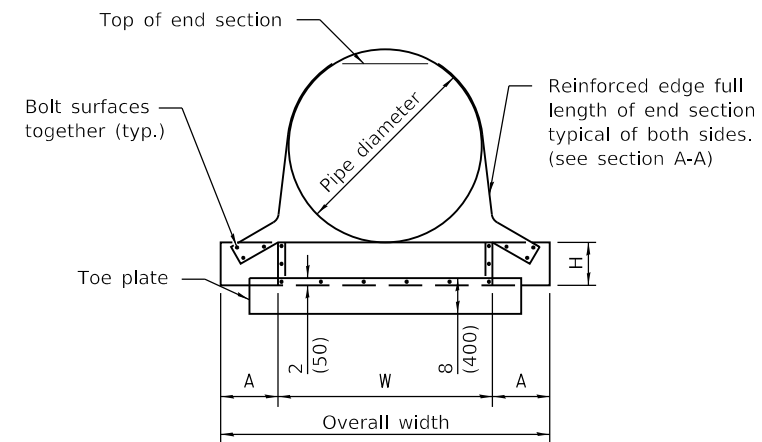

END VIEW

½ (M12) galvanized threaded rod over top of end section. Side lugs shall be bolted to end section

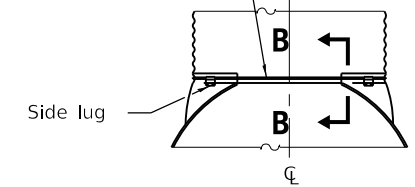

CONNECTIONS OF END SECTION

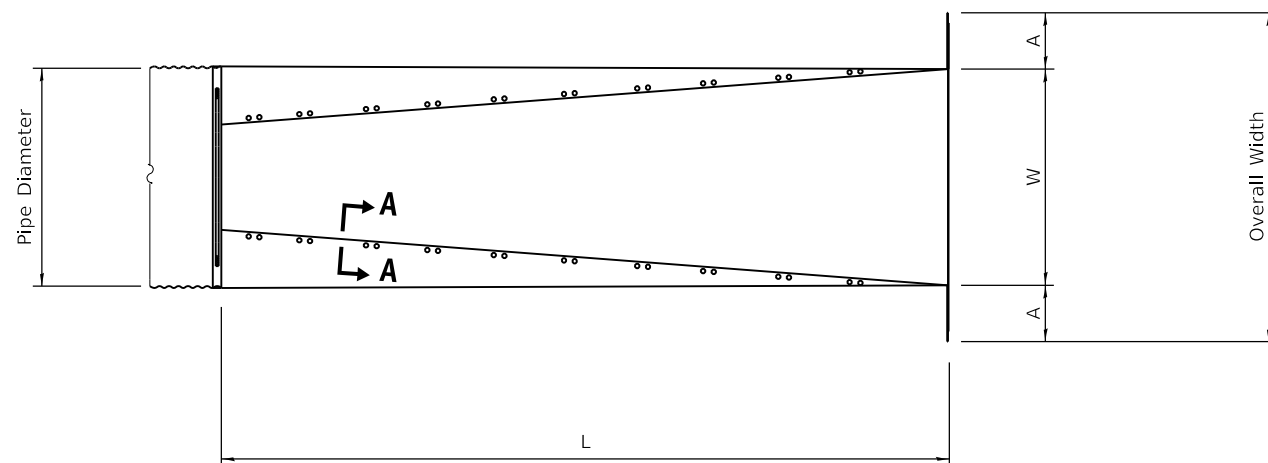

PLAN

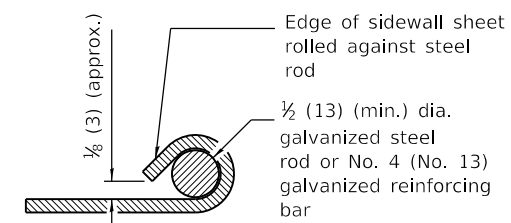

SECTION A-A

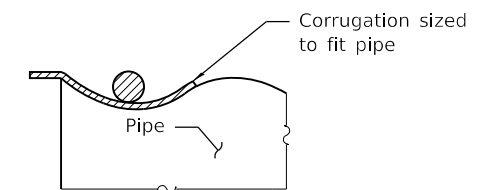

SECTION B-B

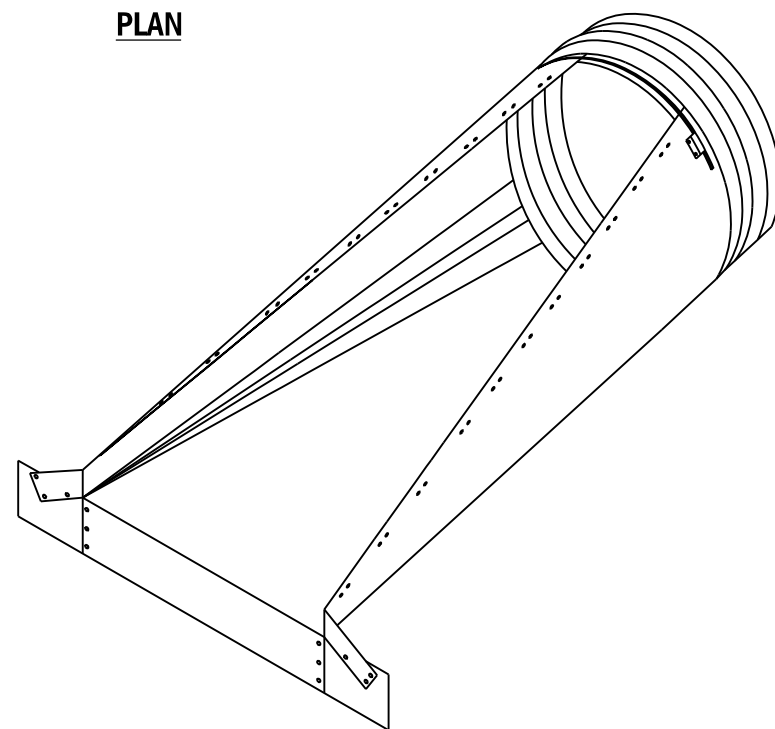

**END SECTION
PERSPECTIVE VIEW**

METAL END SECTIONS FOR ROUND PIPE CULVERT

PIPE DIA.	METAL THICK. (min.)	DIMENSIONS					
		A	H	W	OVERALL WIDTH	L	
						SLOPE 1:4	SLOPE 1:6
15 (375)	0.064 (1.63)	8 (200)	6 (150)	21 (525)	37 (950)	20 (500)	30 (750)
18 (450)	0.064 (1.63)	8 (200)	6 (150)	24 (600)	40 (1000)	32 (800)	48 (1200)
21 (525)	0.064 (1.63)	8 (200)	6 (150)	27 (700)	43 (1100)	44 (1100)	60 (1500)
24 (600)	0.064 (1.63)	8 (200)	6 (150)	30 (750)	46 (1150)	55 (1400)	83 (2100)
30 (750)	0.109 (2.77)	12 (300)	9 (230)	36 (900)	60 (1500)	79 (2000)	118 (3000)
36 (900)	0.109 (2.77)	12 (300)	9 (230)	42 (1050)	66 (1650)	102 (2600)	154 (3900)
42 (1050)	0.109 (2.77)	16 (400)	12 (300)	48 (1200)	80 (2000)	126 (3200)	189 (4800)
48 (1200)	0.109 (2.77)	16 (400)	12 (300)	54 (1350)	86 (2150)	150 (3800)	224 (5700)
54 (1350)	0.109 (2.77)	16 (400)	12 (300)	60 (1500)	92 (2300)	173 (4400)	260 (6600)
60 (1500)	0.109 (2.77)	16 (400)	12 (300)	66 (1650)	98 (2450)	197 (5000)	295 (7500)

GENERAL NOTES

See roadway plans for slope (V:H) and pipe diameter.

Provide traversable pipe grate when specified.

All slope ratios are expressed as units of vertical displacement to units of horizontal displacement (V:H).

All dimensions are in inches (millimeters) unless otherwise shown.

DATE	REVISIONS
1-1-18	New standard.

**SLOPED METAL END SECTIONS
FOR PIPE CULVERTS 15" (375 mm)
THRU 60" (1500 mm) DIA.**
(Sheet 1 of 2)

STANDARD 542411

Illinois Department of Transportation

PASSED January 1, 2018
Michael Beard
ENGINEER OF POLICY AND PROCEDURES

APPROVED January 1, 2018
Marcus M. Adams
ENGINEER OF DESIGN AND ENVIRONMENT

ISSUED 1-1-18

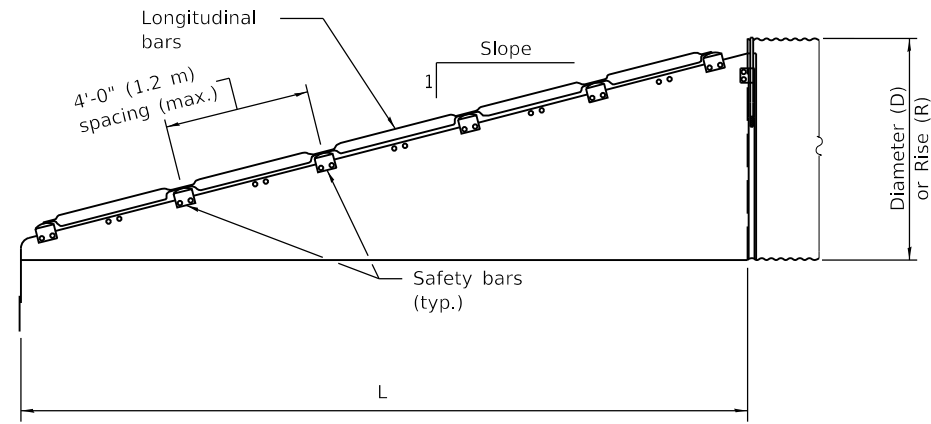

**CROSS DRAINAGE
END SECTION - ELEVATION**

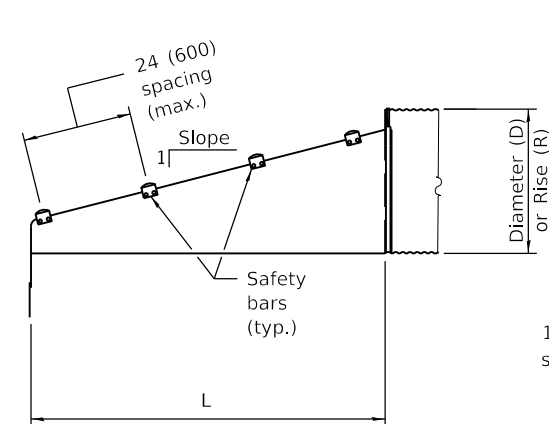

**PARALLEL DRAINAGE
END SECTION - ELEVATION**

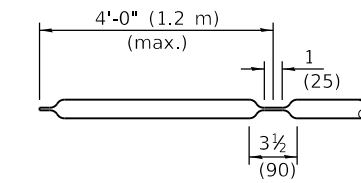

LONGITUDINAL DRAINAGE BAR

1 x 5/8 (25 x 16) slots

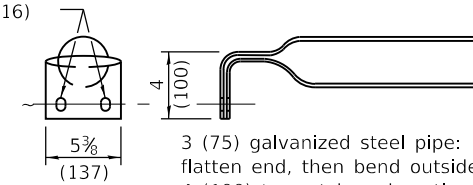

3 (75) galvanized steel pipe: flatten end, then bend outside 4 (100) to match end section sides.

PARALLEL BARS

SAFETY BAR DETAILS

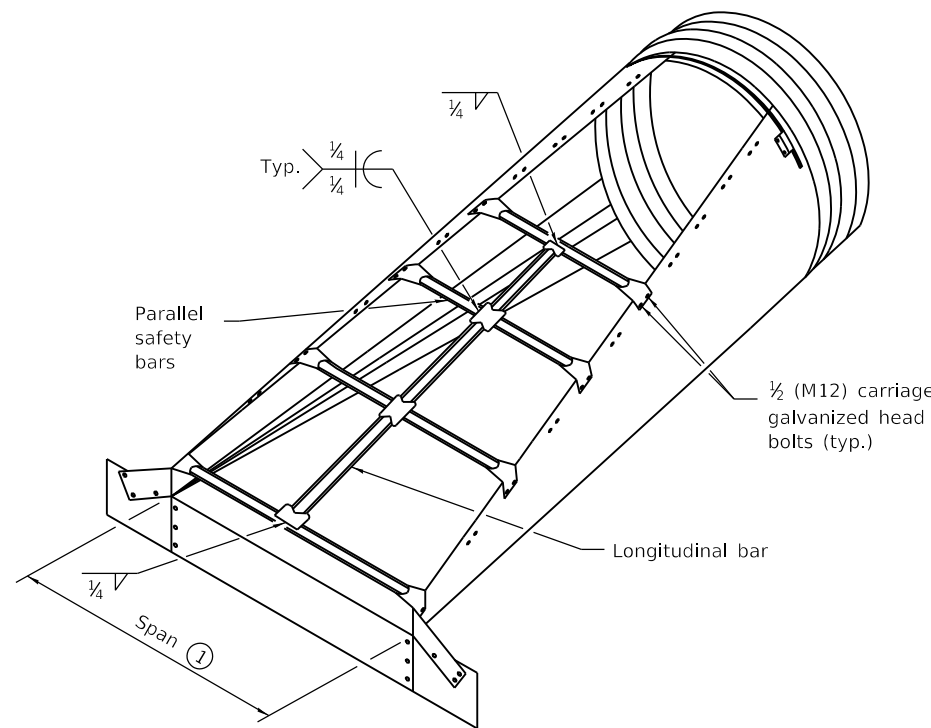

CROSS DRAINAGE END SECTION

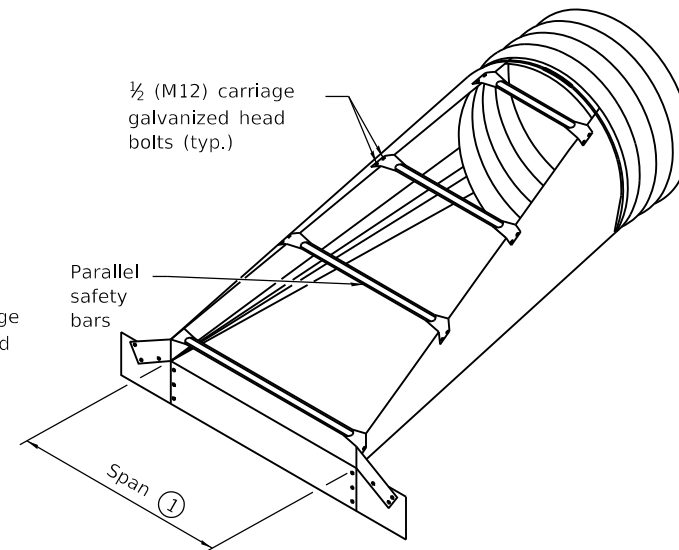

**PARALLEL DRAINAGE
END SECTION**

① Provide longitudinal bar(s) when the span exceeds 30 (750). Provide additional longitudinal bars as needed so that spacing does not exceed 30 (750) for larger end sections.

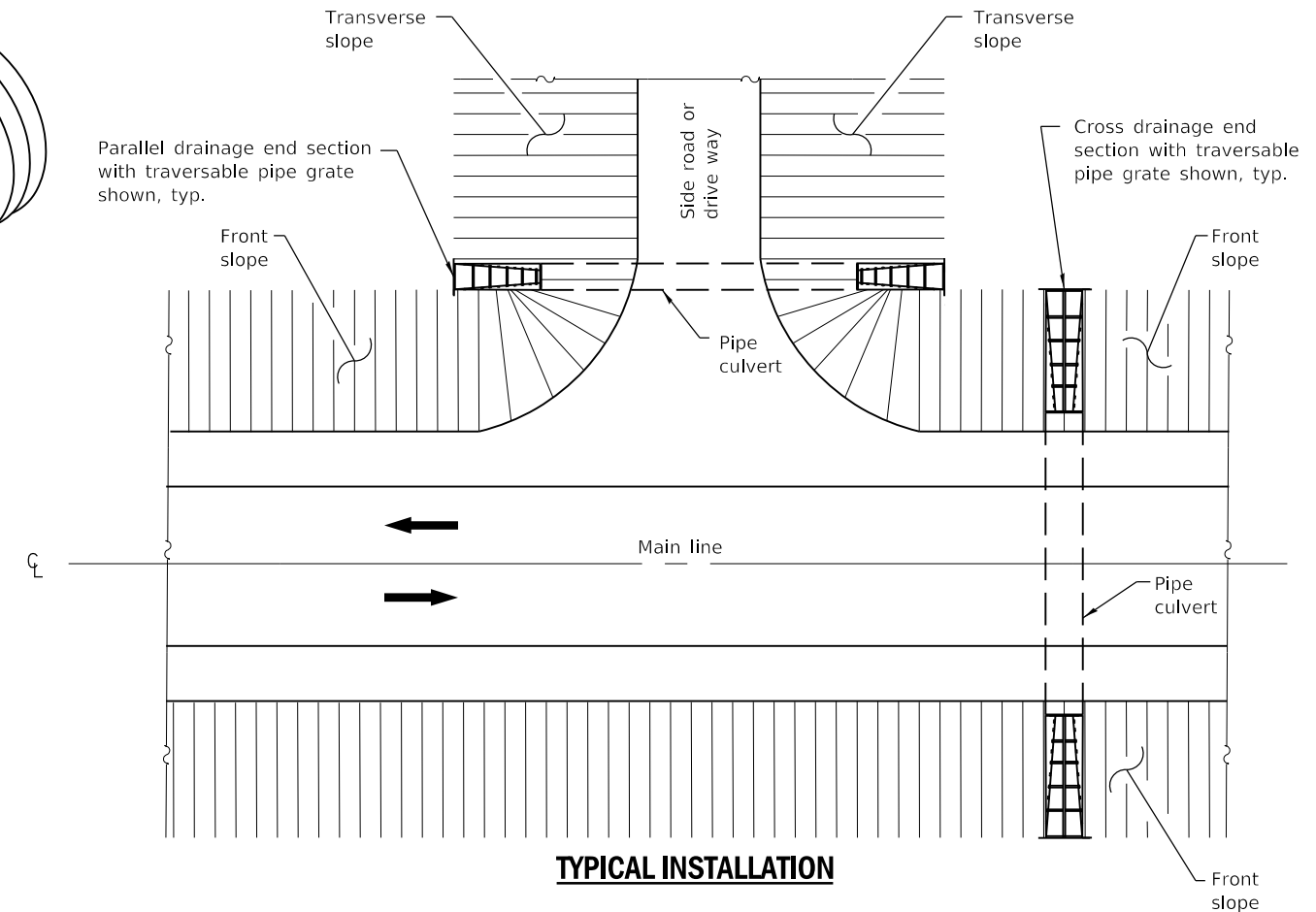

TYPICAL INSTALLATION

Illinois Department of Transportation

PASSED January 1, 2018
Michael Beard
 ENGINEER OF POLICY AND PROCEDURES

APPROVED January 1, 2018
Marcus M. Beck
 ENGINEER OF DESIGN AND ENVIRONMENT

ISSUED 1-1-18

**SLOPED METAL END SECTIONS
FOR PIPE CULVERTS 15" (375 mm)
THRU 60" (1500 mm) DIA.**

(Sheet 2 of 2)

STANDARD 542411

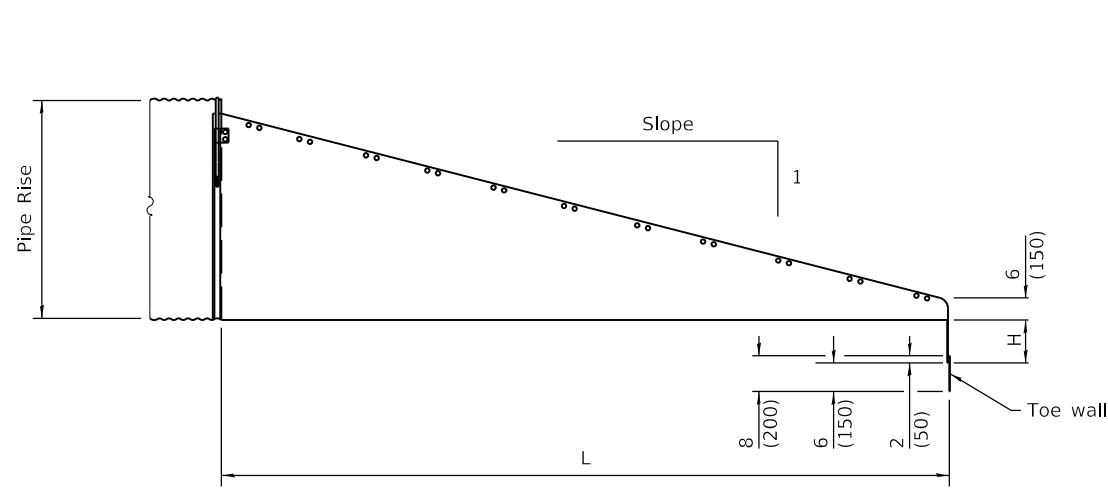

ELEVATION

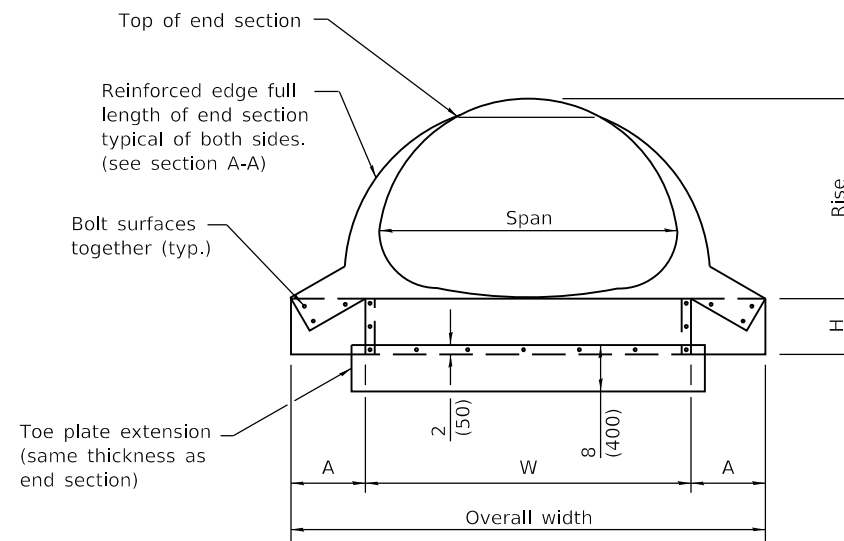

END VIEW

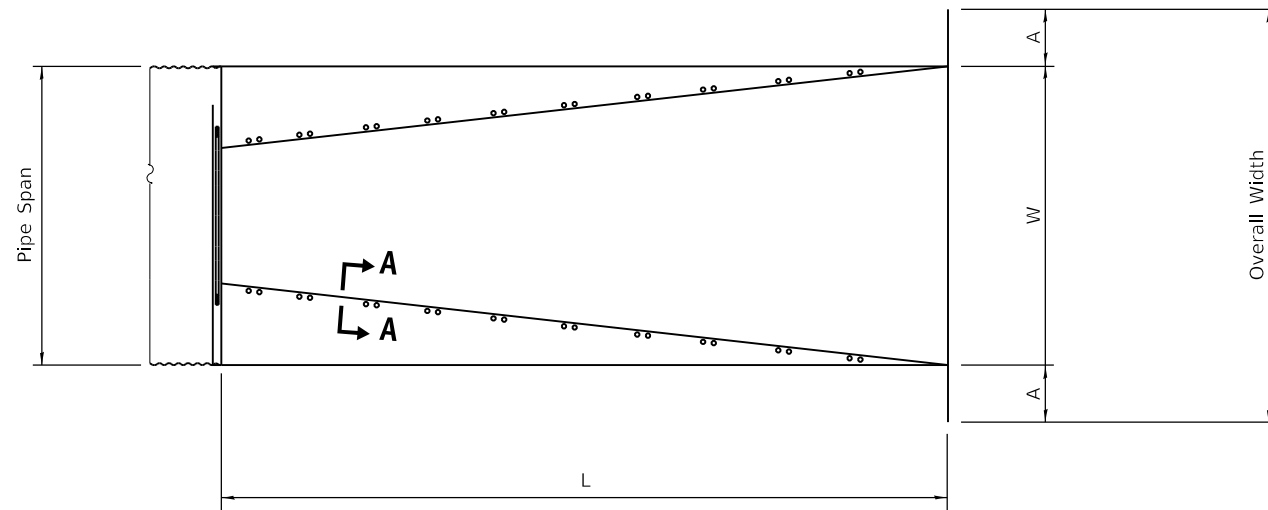

PLAN

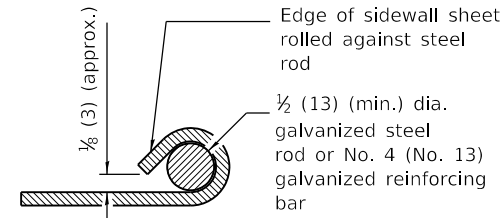

SECTION A-A

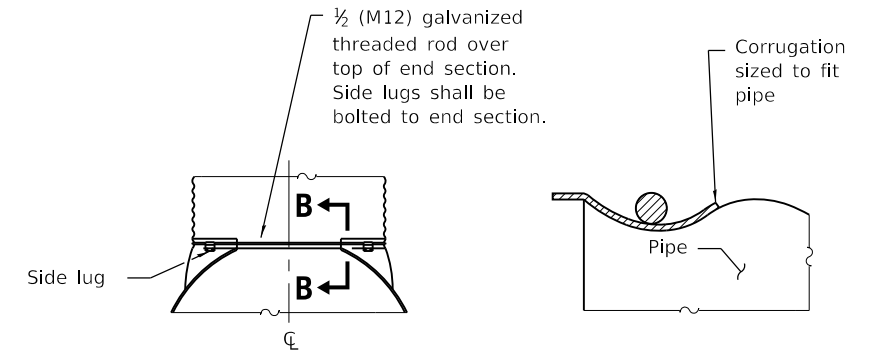

CONNECTIONS OF END SECTION

SECTION B-B

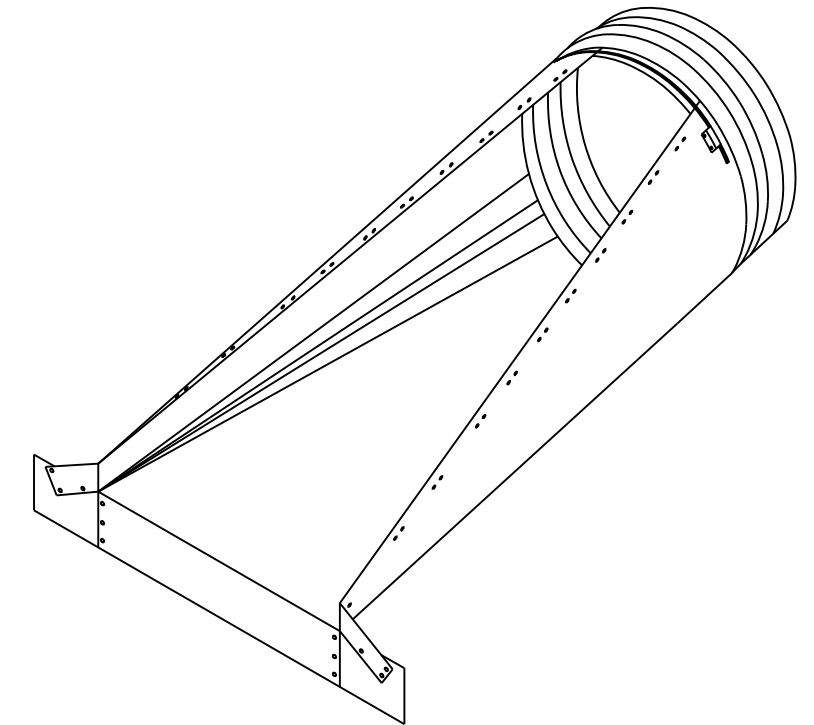

END SECTION PERSPECTIVE VIEW

METAL END SECTIONS FOR PIPE ARCH CULVERT

PIPE EQUIV. ROUND DIA.	METAL THICK. (min.)	DIMENSIONS											
		A	H	W	OVERALL WIDTH	CORRIGATION 2 1/2 x 1/2				CORRIGATION 3 x 1 OR 5 x 1			
						SPAN	RISE	L		SPAN	RISE	L	
								SLOPE 1:4	SLOPE 1:6			SLOPE 1:4	SLOPE 1:6
15 (375)	0.064 (1.63)	8 (200)	6 (150)	23 (585)	39 (1000)	17 (430)	13 (330)	12 (300)	18 (460)	—	—	—	—
18 (450)	0.064 (1.63)	8 (200)	6 (150)	27 (700)	43 (1100)	21 (530)	15 (380)	20 (500)	30 (750)	—	—	—	—
21 (525)	0.064 (1.63)	8 (200)	6 (150)	30 (750)	46 (1150)	24 (610)	18 (460)	32 (810)	48 (1220)	—	—	—	—
24 (600)	0.064 (1.63)	8 (200)	6 (150)	33 (830)	49 (1250)	28 (700)	20 (500)	40 (1000)	60 (1500)	—	—	—	—
30 (750)	0.109 (2.77)	12 (300)	9 (225)	40 (1025)	64 (1625)	35 (870)	24 (630)	55 (1400)	83 (2100)	—	—	—	—
36 (900)	0.109 (2.77)	12 (300)	9 (225)	47 (1200)	71 (1800)	42 (1060)	29 (740)	75 (1900)	112 (2850)	—	—	—	—
42 (1050)	0.109 (2.77)	16 (400)	12 (300)	54 (1375)	86 (2175)	49 (1240)	33 (840)	90 (2300)	136 (3450)	—	—	—	—
48 (1200)	0.109 (2.77)	16 (400)	12 (300)	62 (1575)	94 (2375)	57 (1440)	38 (970)	110 (2800)	165 (4200)	53 (1340)	41 (1050)	124 (3150)	186 (4720)
54 (1350)	0.109 (2.77)	16 (400)	12 (300)	69 (1750)	101 (2550)	64 (1620)	43 (1100)	130 (3300)	195 (4950)	60 (1520)	46 (1170)	144 (3660)	216 (5490)
60 (1500)	0.109 (2.77)	16 (400)	12 (300)	76 (1925)	107 (2725)	71 (1800)	47 (1200)	146 (3700)	218 (5550)	66 (1670)	51 (1300)	164 (4170)	246 (6250)
66 (1650)	0.109 (2.77)	16 (400)	12 (300)	79 (2000)	111 (2800)	77 (1950)	52 (1320)	180 (4600)	270 (6850)	73 (1850)	55 (1400)	180 (4580)	270 (6860)
72 (1800)	0.109 (2.77)	16 (400)	12 (300)	88 (2225)	120 (3025)	83 (2100)	57 (1450)	185 (4700)	278 (7050)	81 (2050)	59 (1500)	196 (4980)	294 (7470)

GENERAL NOTES

See roadway plans for slope (V:H) and pipe diameter.

Provide traversable pipe grate when specified.

All slope ratios are expressed as units of vertical displacement to units of horizontal displacement (V:H).

All dimensions are in inches (millimeters) unless otherwise shown.

DATE	REVISIONS
1-1-18	New standard.

SLOPED METAL END SECTIONS FOR PIPE ARCH CULVERTS 15" (375 mm) THRU 72" (1800 mm) EQUIVALENT DIA.

(Sheet 1 of 2)

STANDARD 542416

Illinois Department of Transportation

PASSED January 1, 2018
Michael Brand
 ENGINEER OF POLICY AND PROCEDURES

APPROVED January 1, 2018
Marcus M. Adams
 ENGINEER OF DESIGN AND ENVIRONMENT

ISSUED 1-1-18

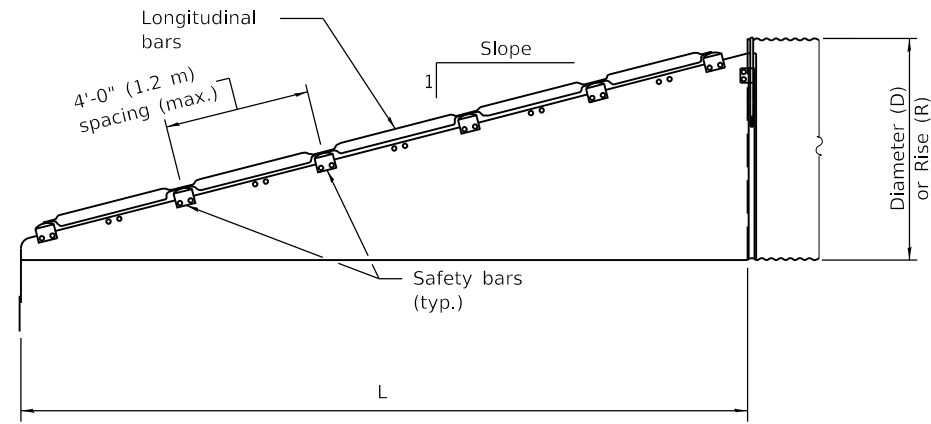

**CROSS DRAINAGE
END SECTION - ELEVATION**

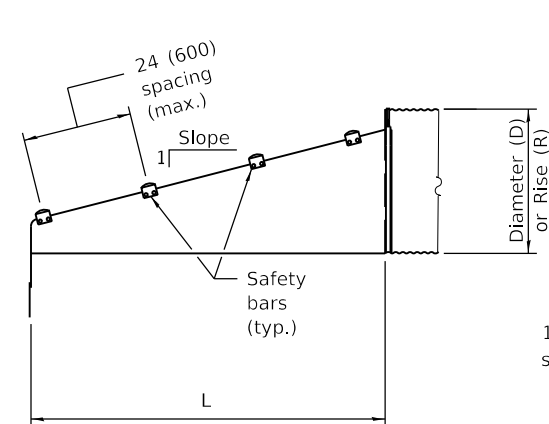

**PARALLEL DRAINAGE
END SECTION - ELEVATION**

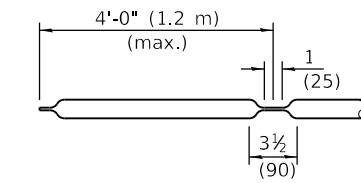

LONGITUDINAL DRAINAGE BAR

1 x 5/8 (25 x 16) slots

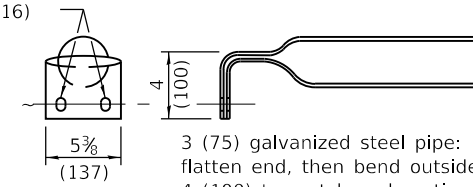

3 (75) galvanized steel pipe: flatten end, then bend outside 4 (100) to match end section sides.

PARALLEL BARS

SAFETY BAR DETAILS

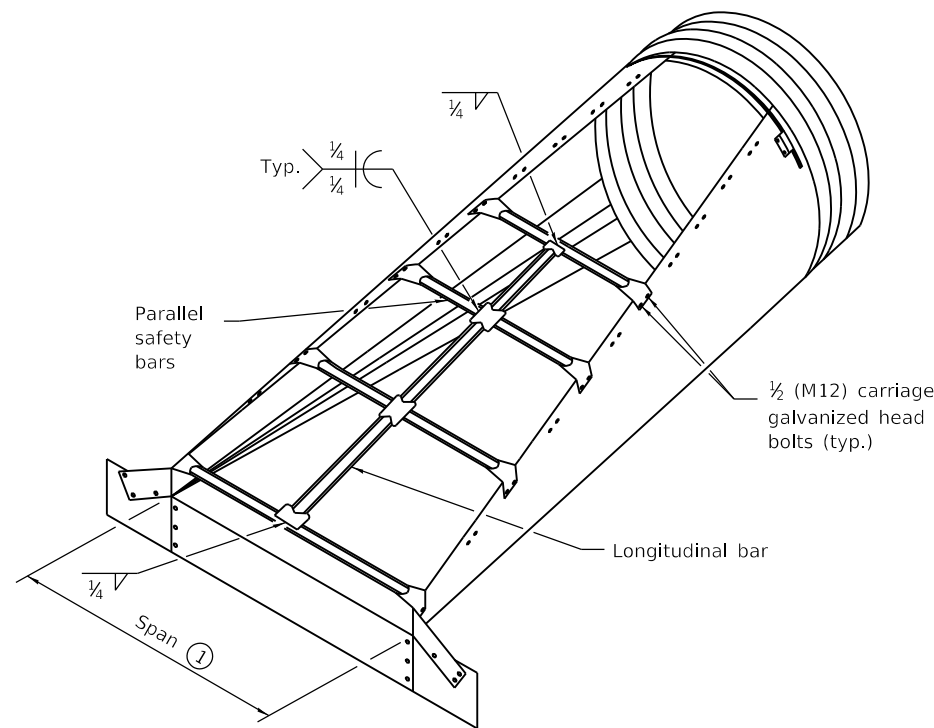

CROSS DRAINAGE END SECTION

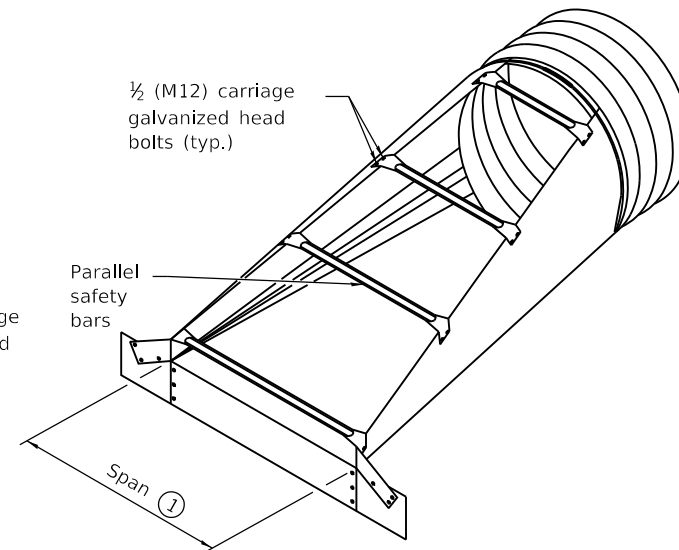

**PARALLEL DRAINAGE
END SECTION**

① Provide longitudinal bar(s) when the span exceeds 30 (750). Provide additional longitudinal bars as needed so that spacing does not exceed 30 (750) for larger end sections.

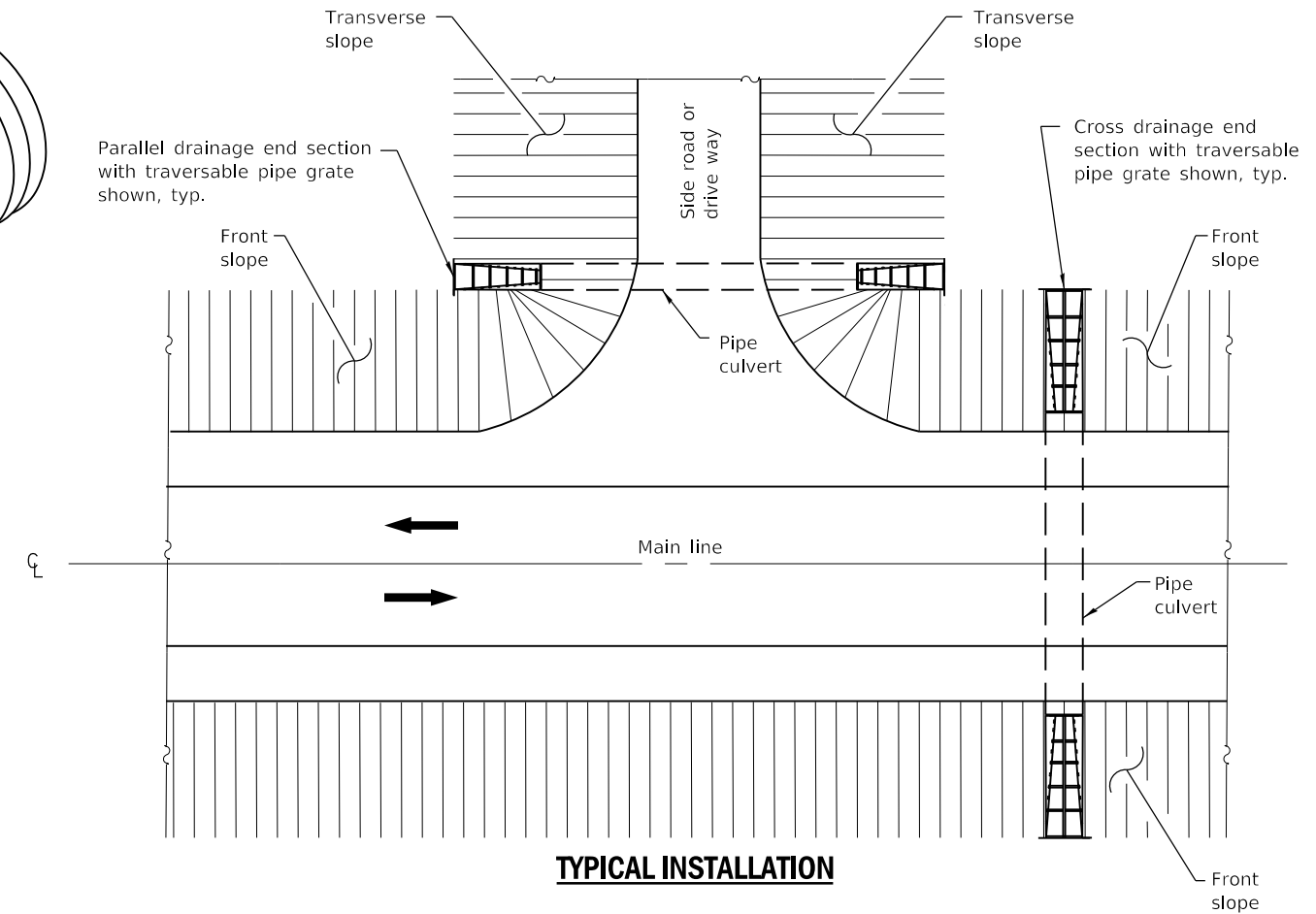

TYPICAL INSTALLATION

Illinois Department of Transportation

PASSED January 1, 2018
Michael Beard
 ENGINEER OF POLICY AND PROCEDURES

APPROVED January 1, 2018
Maureen M. Beck
 ENGINEER OF DESIGN AND ENVIRONMENT

ISSUED 1-1-18

**SLOPED METAL END SECTIONS FOR PIPE
ARCH CULVERTS 15" (375 mm) THRU
72" (1800 mm) EQUIVALENT DIA.**

(Sheet 2 of 2)

STANDARD 542416

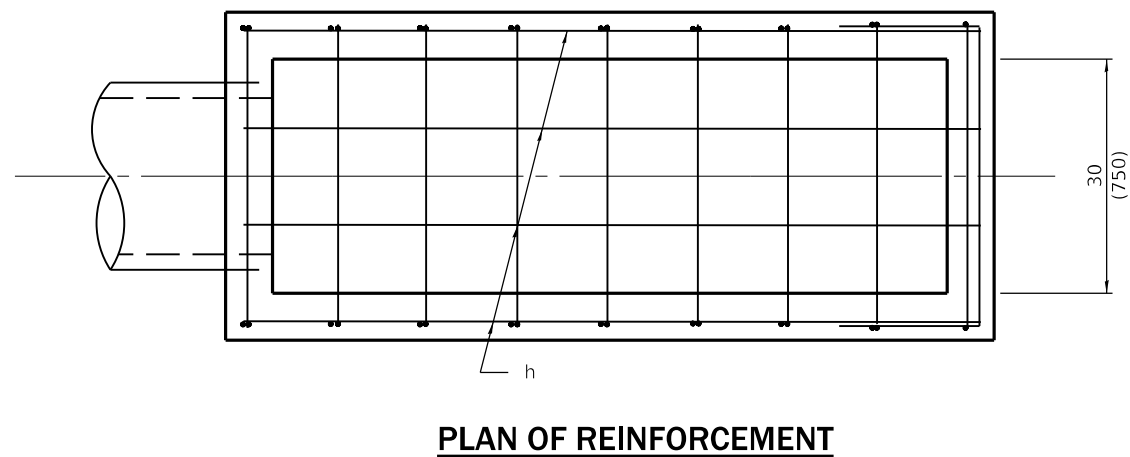
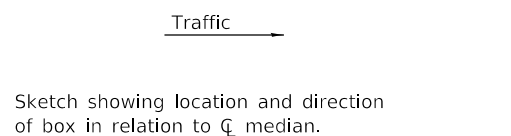
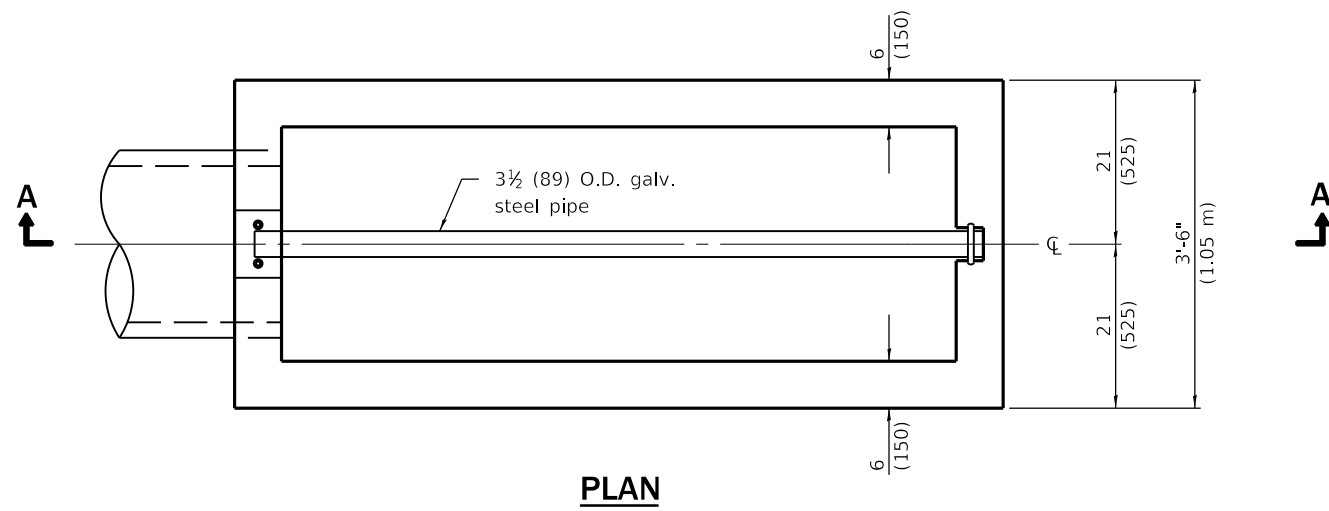
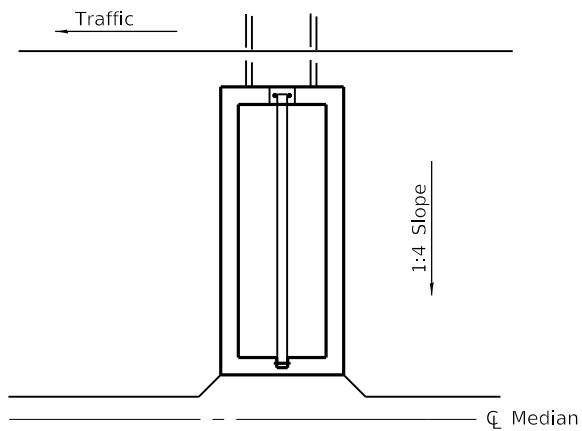
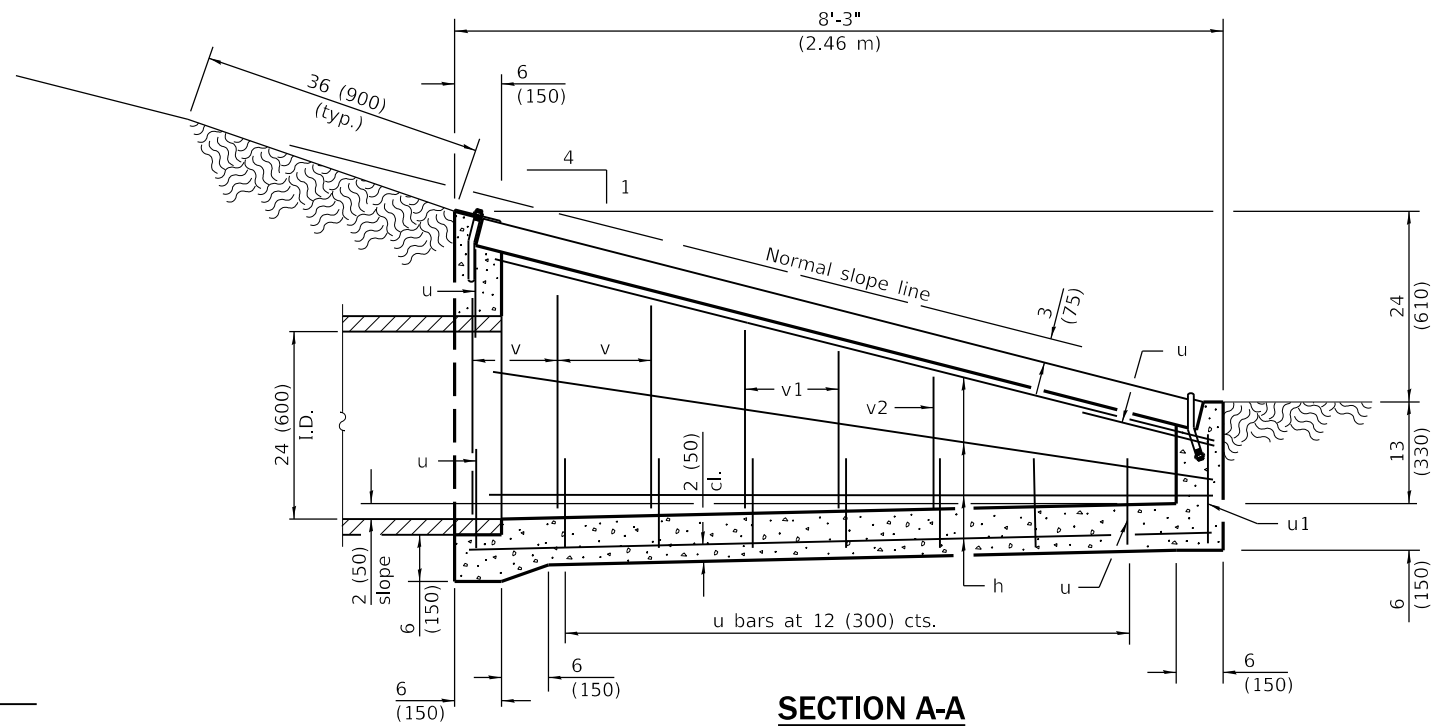

Material required for one inlet box

Bar	Qty.	Size	Length
h	10	No. 4 (No. 13)	7'-9" (2.35 m)
u	10	No. 4 (No. 13)	6'-3" (1.90 m)
u1	1	No. 4 (No. 13)	5'-8" (1.70 m)
v	6	No. 4 (No. 13)	30 (760)
v1	4	No. 4 (No. 13)	24 (610)
v2	2	No. 4 (No. 13)	18 (460)
Galv. Steel Pipe		3 1/2 (89) O.D.	8'-0" (2.38 m)
Concrete		cu. yds. (m ³)	1.2 (0.9)
Reinf. Bars		lbs. (kg)	115 (52.2)

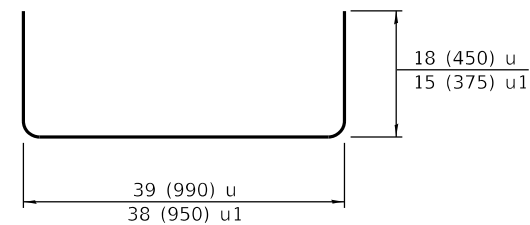

Bars u & u1

GENERAL NOTES
 All slope ratios are expressed as units of vertical displacement to units of horizontal displacement (V:H).
 All dimensions are in inches (millimeters) unless otherwise shown.

DATE	REVISIONS
1-1-09	Switched units to English (metric).
1-1-07	Soft converted metric reinforcement bars.

**INLET BOX
 TYPE 24 (600) A**

(Sheet 1 of 2)

STANDARD 542501-02

Illinois Department of Transportation

PASSED January 1, 2009
 ENGINEER OF POLICY AND PROCEDURES

APPROVED January 1, 2009
 ENGINEER OF DESIGN AND ENVIRONMENT

ISSUED 1-1-09

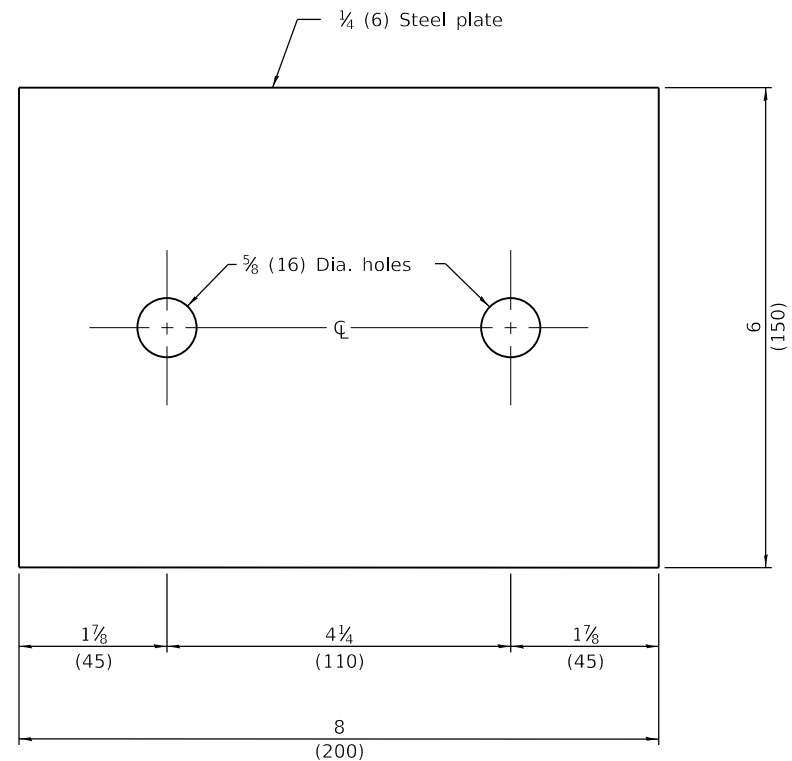

TOP ANCHOR PLATE

(1 - required)

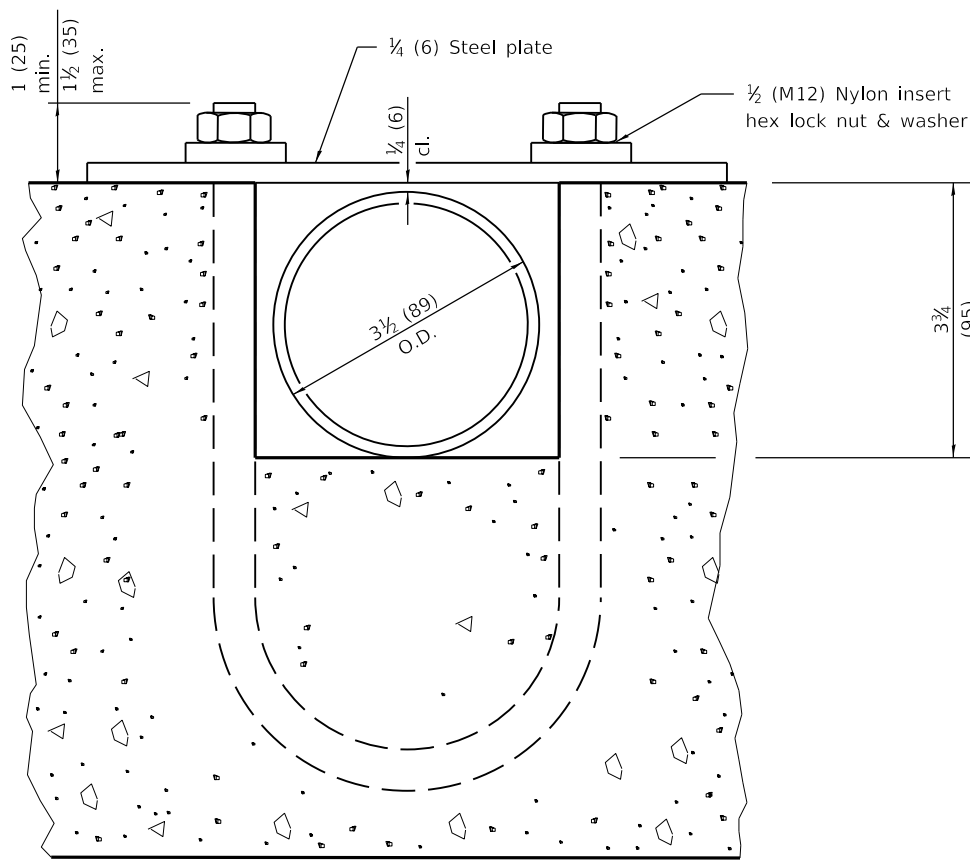

SECTION B-B

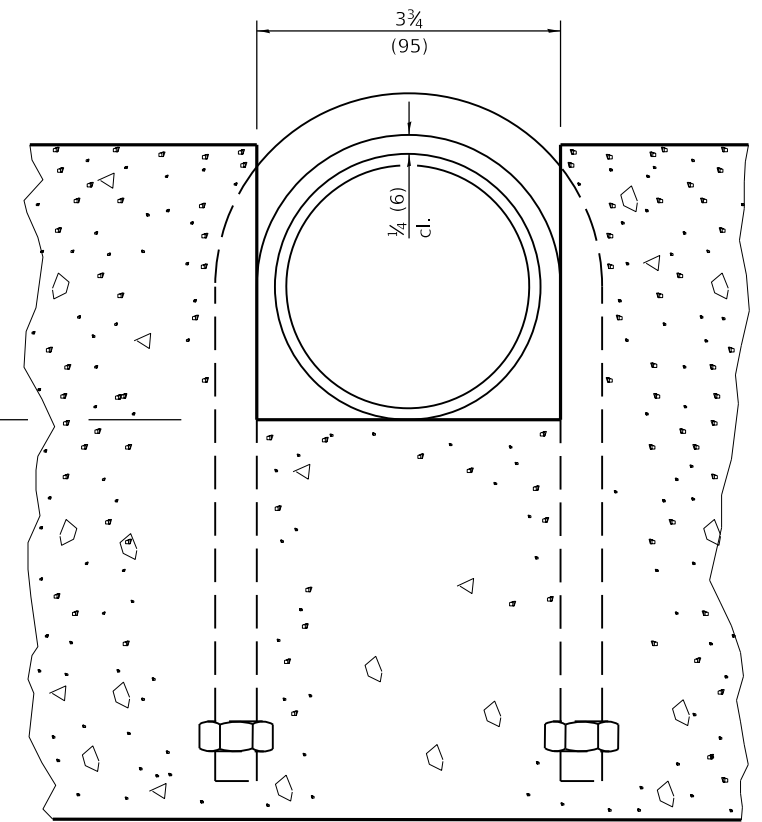

SECTION C-C

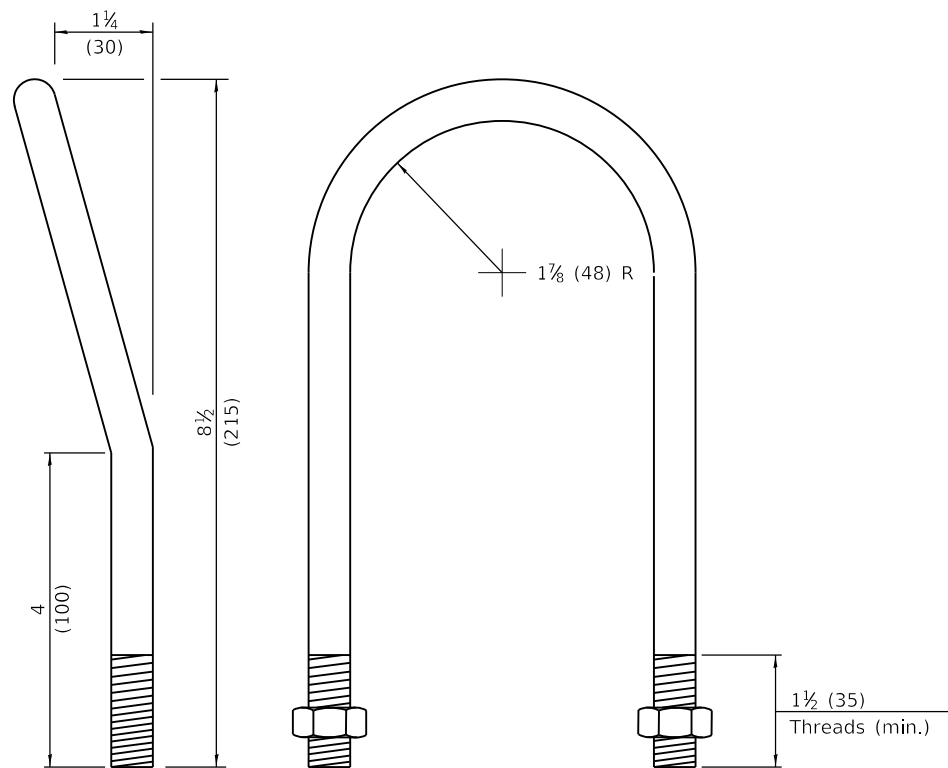

1/2 (M12) U BOLT

(2 - required)

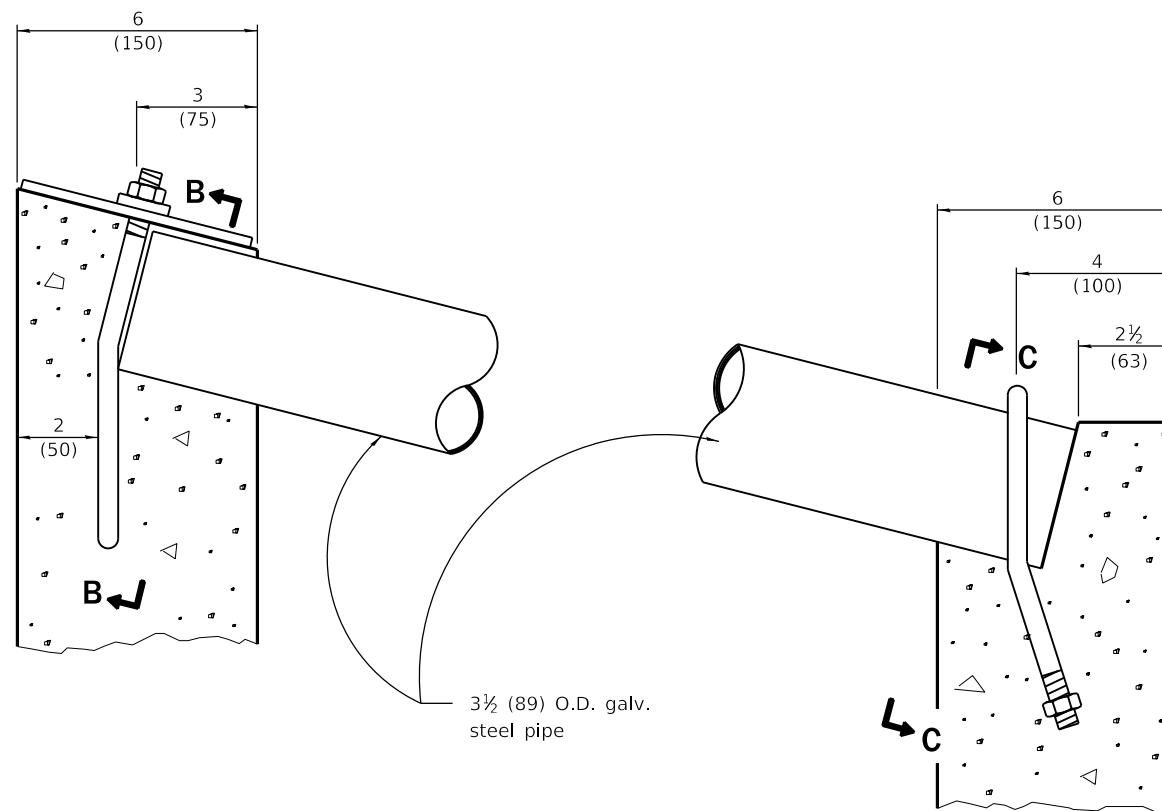

DETAIL AT BLOCKOUTS

Illinois Department of Transportation

PASSED January 1, 2009

ENGINEER OF POLICY AND PROCEDURES

APPROVED January 1, 2009

ENGINEER OF DESIGN AND ENVIRONMENT

ISSUED 1-1-97

**INLET BOX
TYPE 24 (600) A**

(Sheet 2 of 2)

STANDARD 542501-02

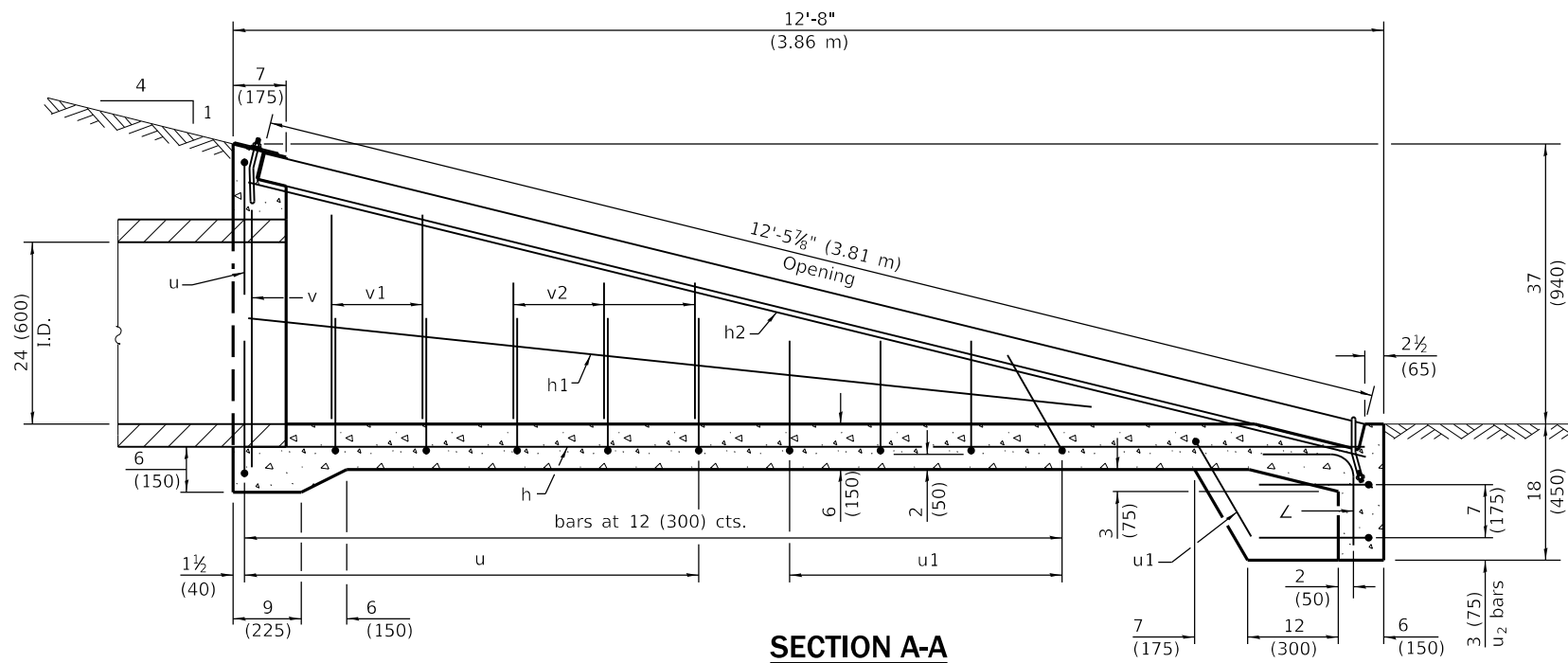

SECTION A-A

Material required for one inlet box

Bar	Qty.	Size	Length
h	4	No. 4 (No. 13)	12'-4" (3.76 m)
h1	2	No. 4 (No. 13)	9'-4" (2.84 m)
h2	2	No. 4 (No. 13)	12'-8" (3.86 m)
∟	4	No. 4 (No. 13)	2'-0" (0.60 m)
u	7	No. 4 (No. 13)	6'-5" (1.95 m)
u1	5	No. 4 (No. 13)	5'-11" (1.80 m)
u2	2	No. 4 (No. 13)	5'-10" (1.75 m)
v	2	No. 4 (No. 13)	34 (864)
v1	4	No. 4 (No. 13)	27 (680)
v2	6	No. 4 (No. 13)	18 (460)
Concrete		cu. yds. (m ³)	1.9 (1.5)
Reinf. Bars		lbs. (kg)	141 (64.0)
Galv. Steel Pipe		3 1/2 (89) O.D.	12'-5 7/8" (3.80 m)

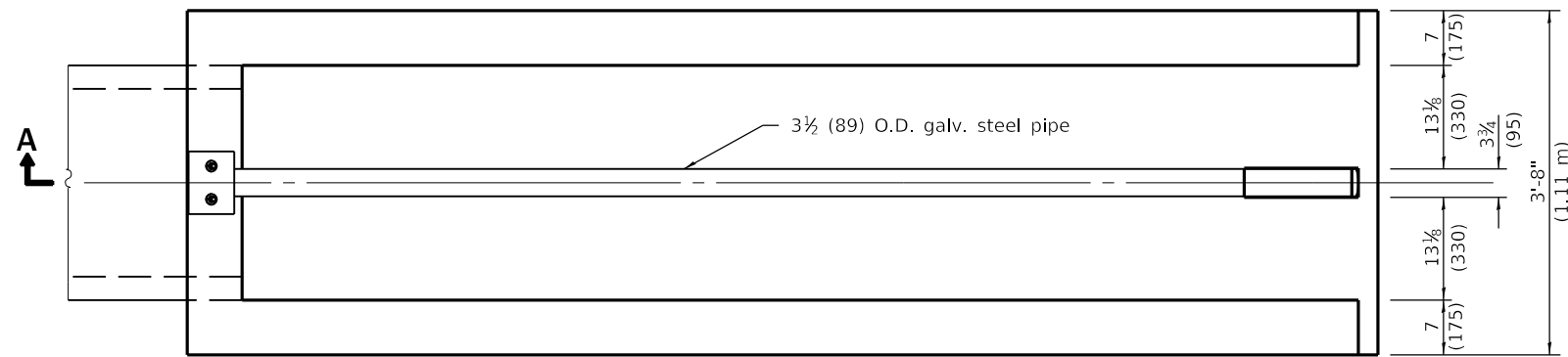
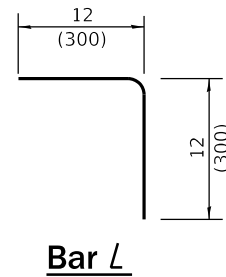

PLAN

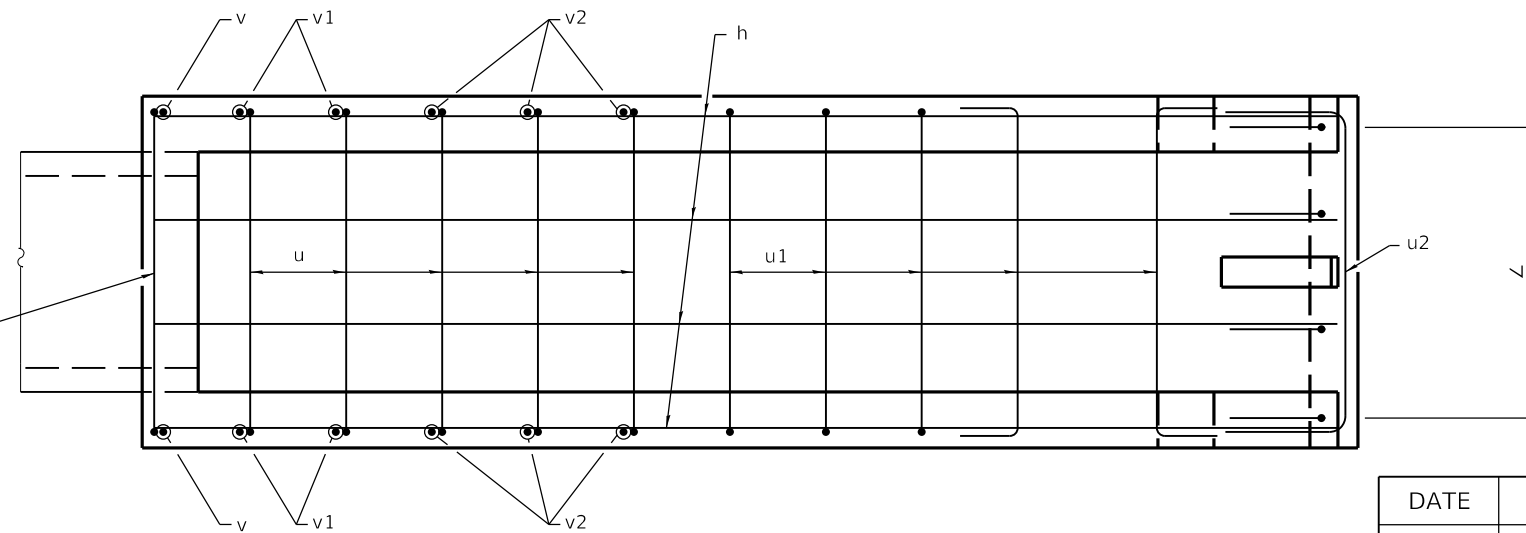
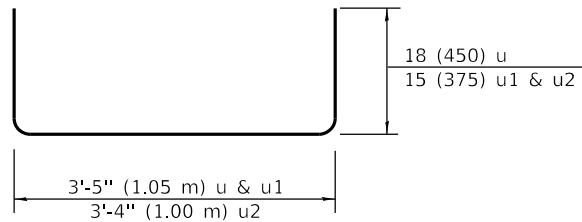
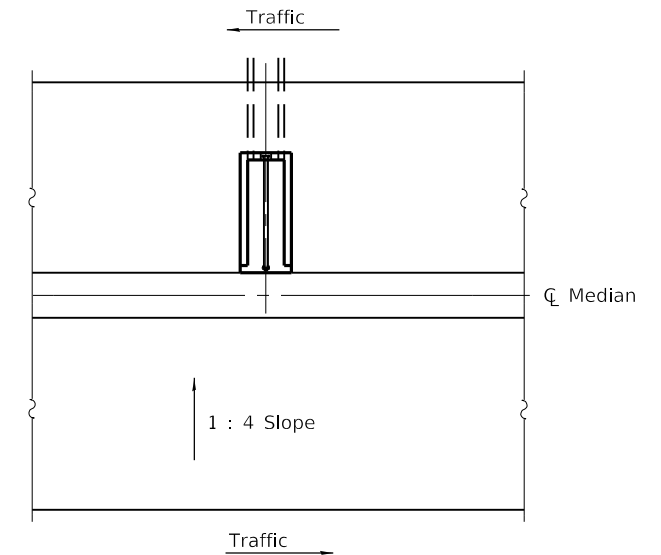

PLAN OF REINFORCEMENT

Sketch showing location and direction of box in relation to \bar{C} median.

GENERAL NOTES

All slope ratios are expressed as units of vertical displacement to units of horizontal displacement (V:H).

All dimensions are in inches (millimeters) unless otherwise shown.

DATE	REVISIONS
4-1-16	Increased length of inlet box to provide clearance for top u-bolt.
1-1-09	Switched units to English (metric).

**INLET BOX
TYPE 24 (600) B**

(Sheet 1 of 2)

STANDARD 542506-03

Illinois Department of Transportation

PASSED April 1, 2016

Michael Beard
ENGINEER OF POLICY AND PROCEDURES

APPROVED April 1, 2016

[Signature]
ENGINEER OF DESIGN AND ENVIRONMENT

ISSUED 1-1-09

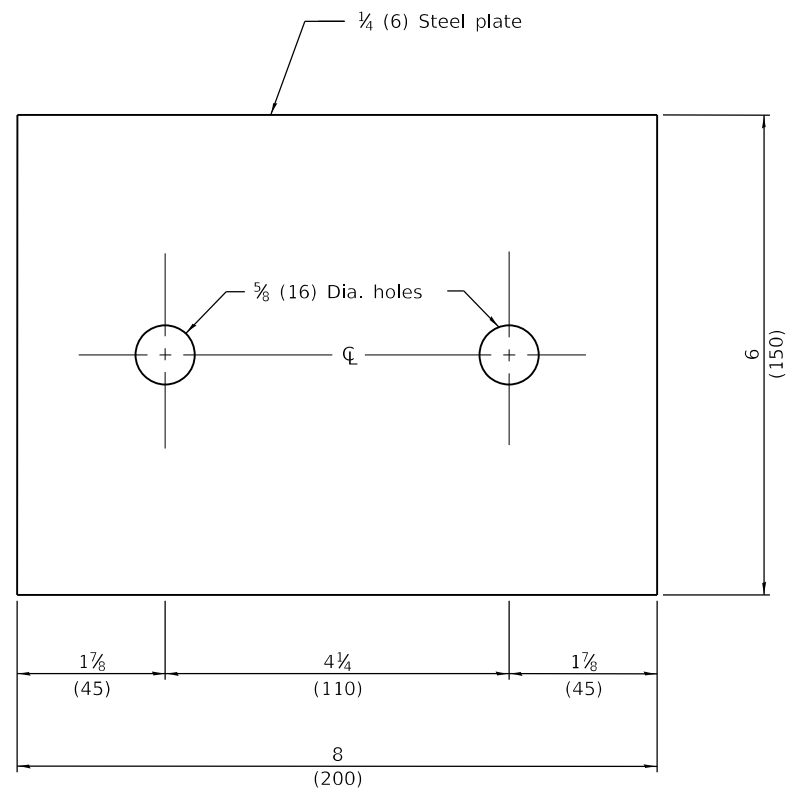

TOP ANCHOR PLATE
(1 - required)

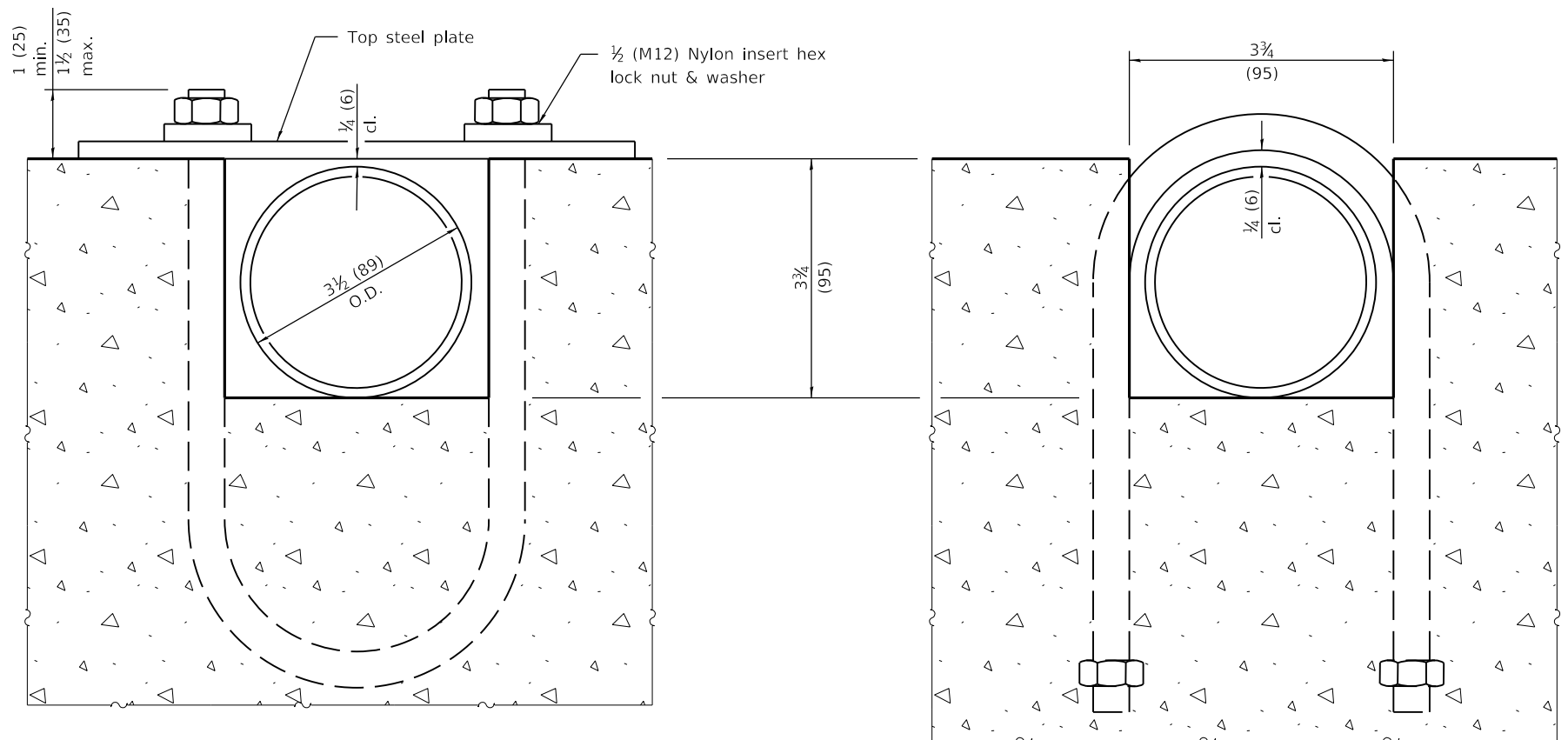

SECTION B-B

SECTION C-C

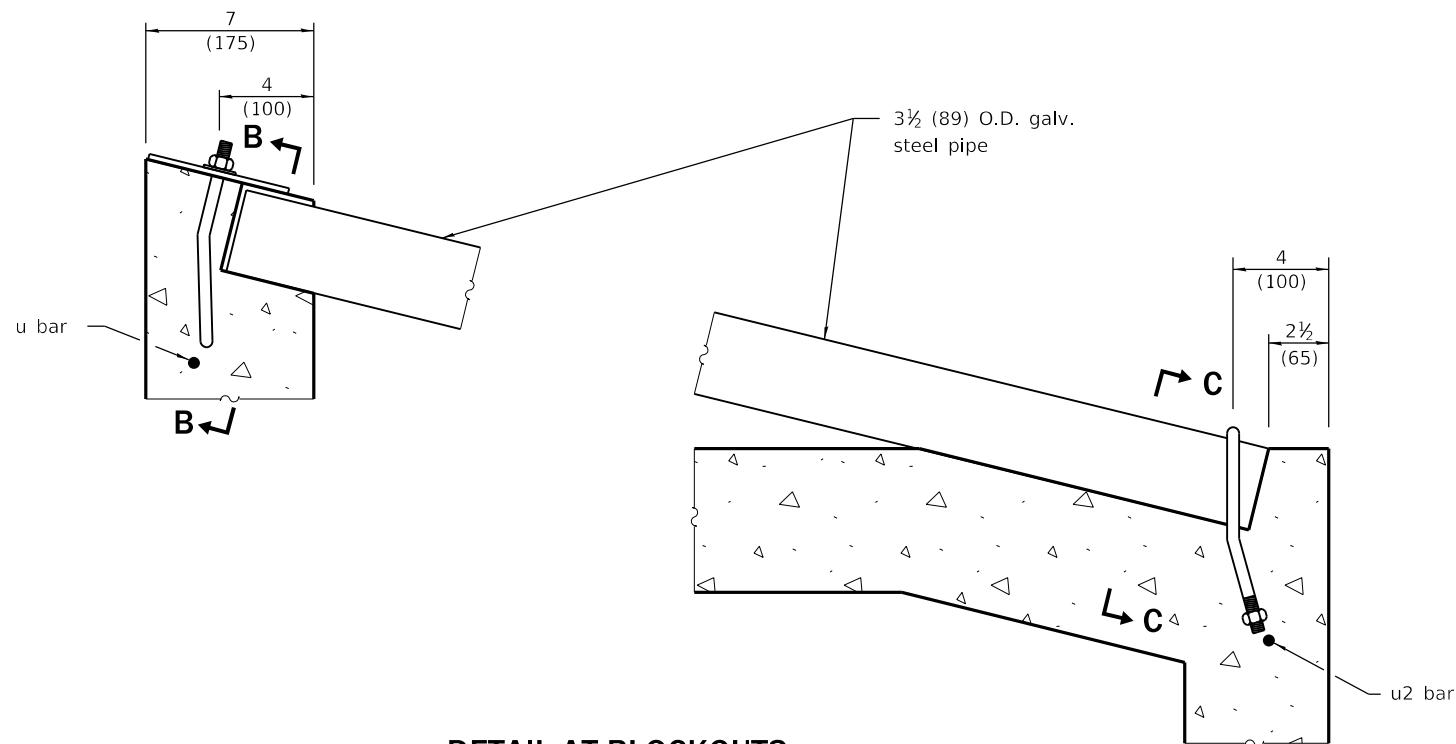

DETAIL AT BLOCKOUTS

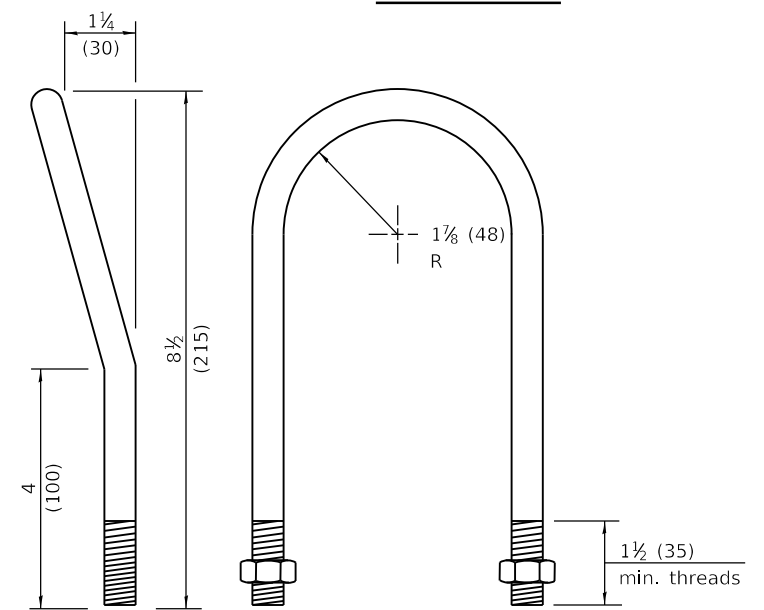

1/2 (M12) U BOLT
(2 - required)

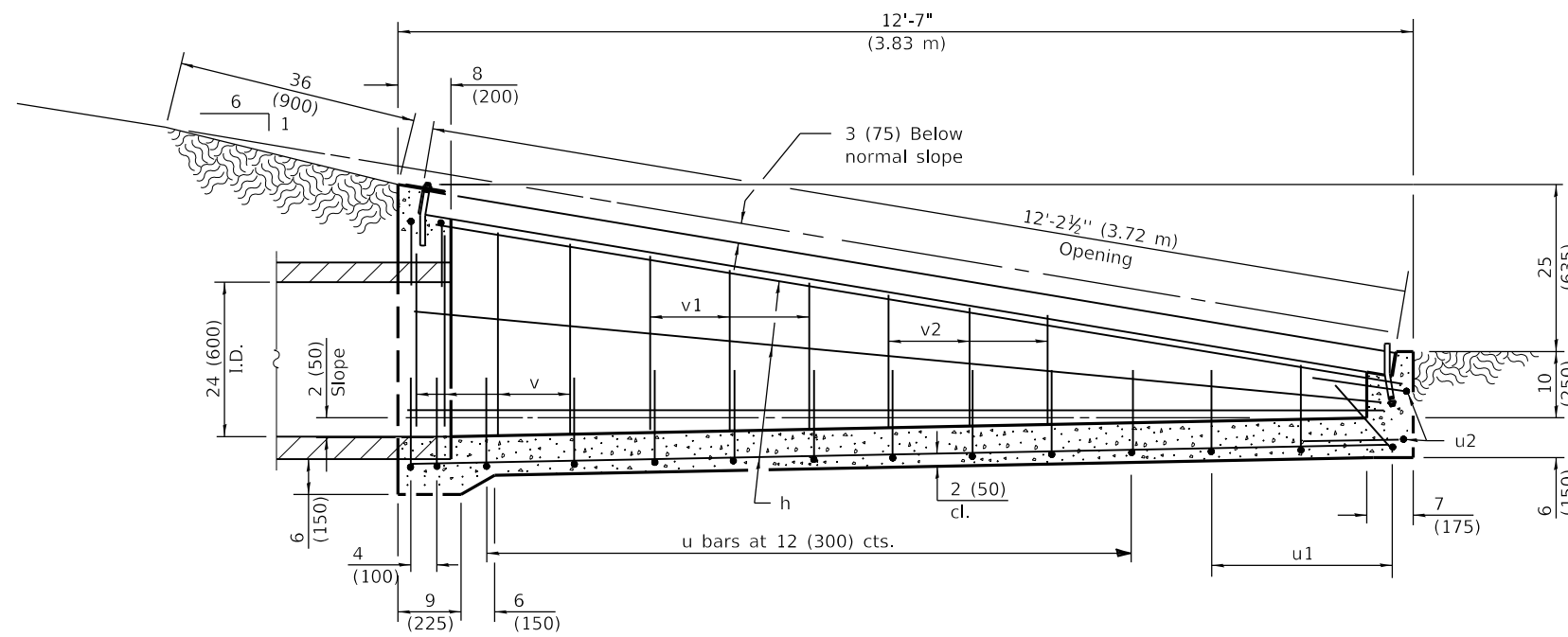

SECTION A-A

Material required for one inlet box

Bar	Qty.	Size	Length
h	10	No. 4 (No. 13)	12'-0" (3.65 m)
u	13	No. 4 (No. 13)	6'-5" (1.95 m)
u1	3	No. 4 (No. 13)	5'-11" (1.80 m)
u2	2	No. 4 (No. 13)	5'-10" (1.75 m)
v	8	No. 4 (No. 13)	30 (760)
v1	6	No. 4 (No. 13)	24 (610)
v2	6	No. 4 (No. 13)	18 (460)
Concrete	cu. yds. (m ³)		1.9 (1.45)
Reinf. Bars	lbs. (kg)		83 (183)
Galv. Steel Pipe	3 1/2 (89) O.D.		12'-2 1/4" (3.71 m)

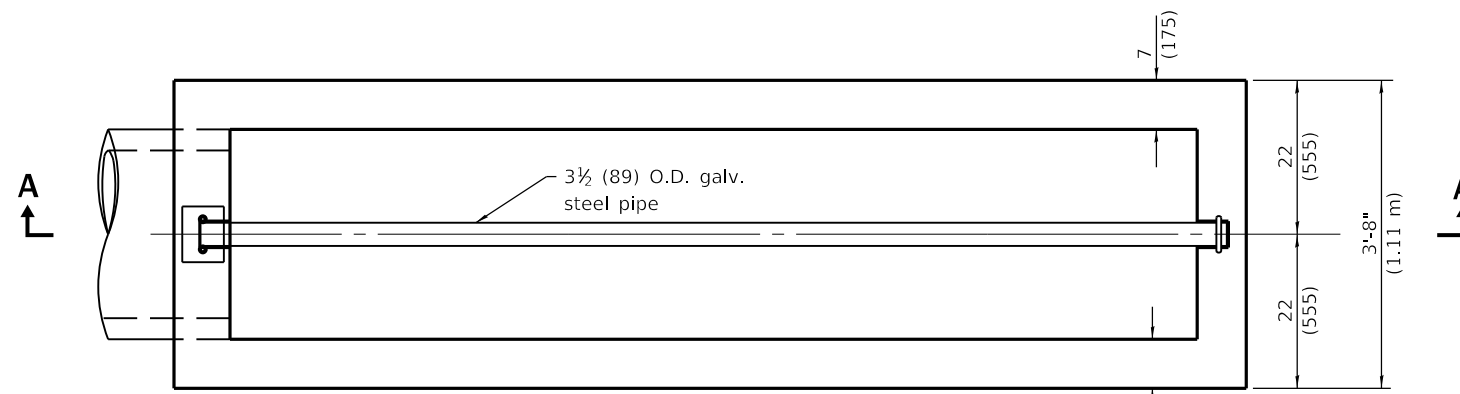

PLAN

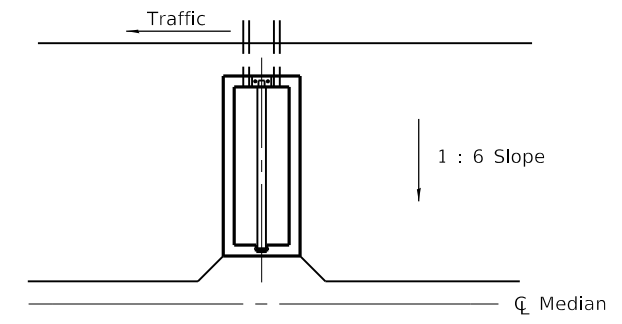

Sketch showing location and direction of box in relation to median.

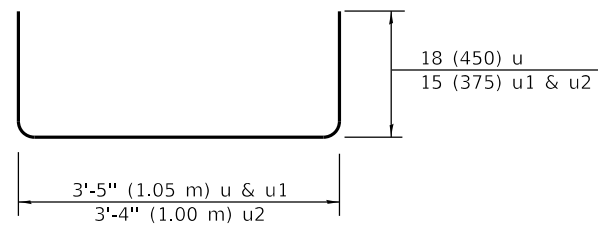

Bars u, u1 & u2

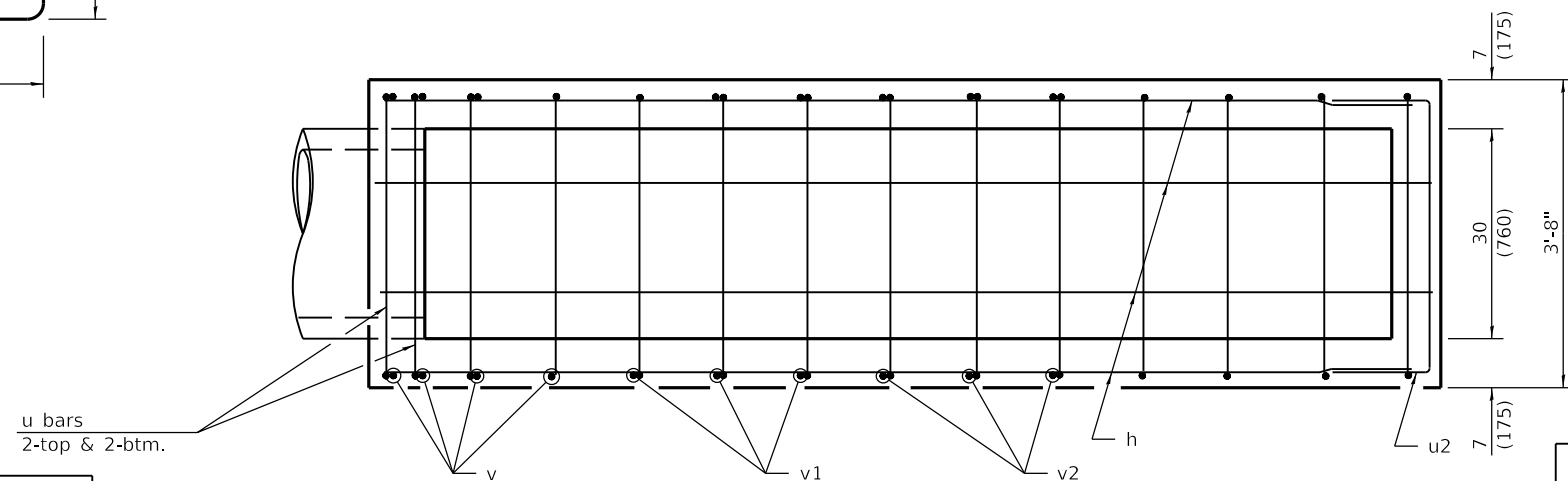

PLAN OF REINFORCEMENT

GENERAL NOTES

All slope ratios are expressed as units of vertical displacement to units of horizontal displacement (V:H).

All dimensions are in inches (millimeters) unless otherwise shown.

DATE	REVISIONS
1-1-09	Switched units to English (metric).
1-1-07	Soft converted metric reinforcement bars.

**INLET BOX
TYPE 24 (600) C**

(Sheet 1 of 2)

STANDARD 542511-02

Illinois Department of Transportation

PASSED January 1, 2009

ENGINEER OF POLICY AND PROCEDURES

APPROVED January 1, 2009

ENGINEER OF DESIGN AND ENVIRONMENT

ISSUED 1-1-97

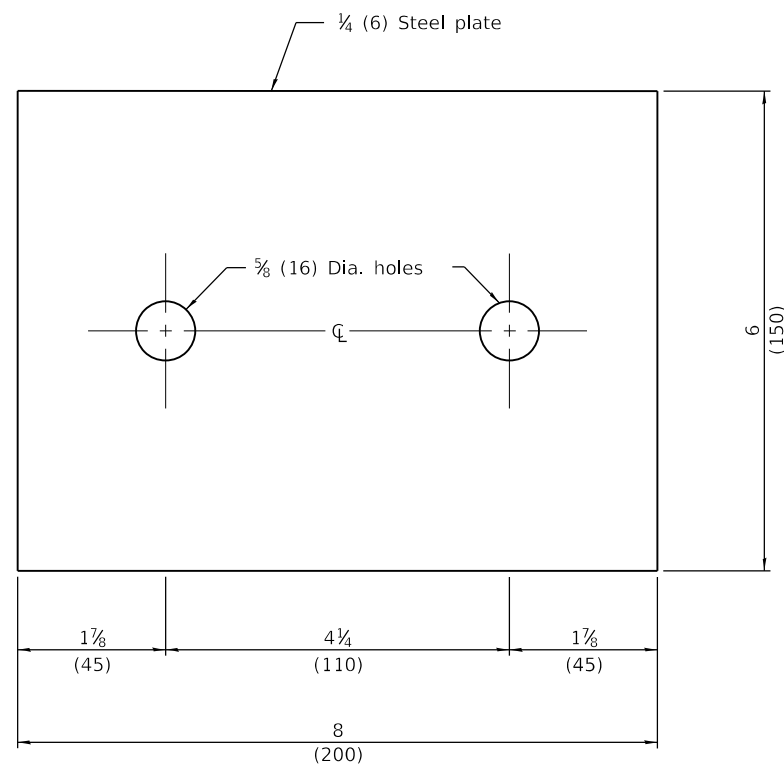

TOP ANCHOR PLATE
(1 - required)

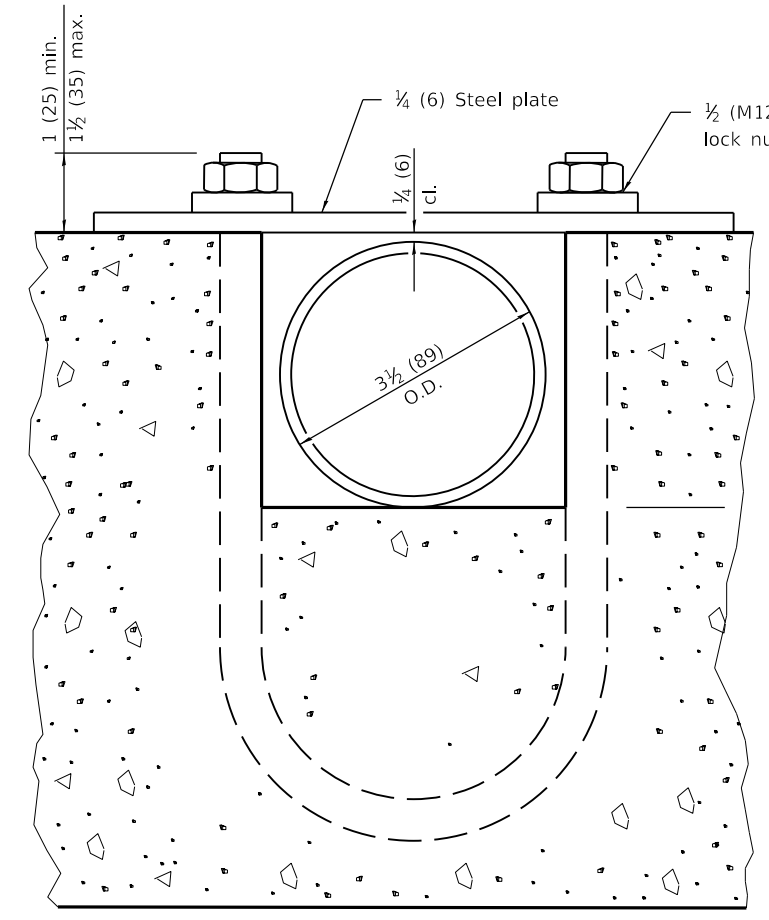

SECTION B-B

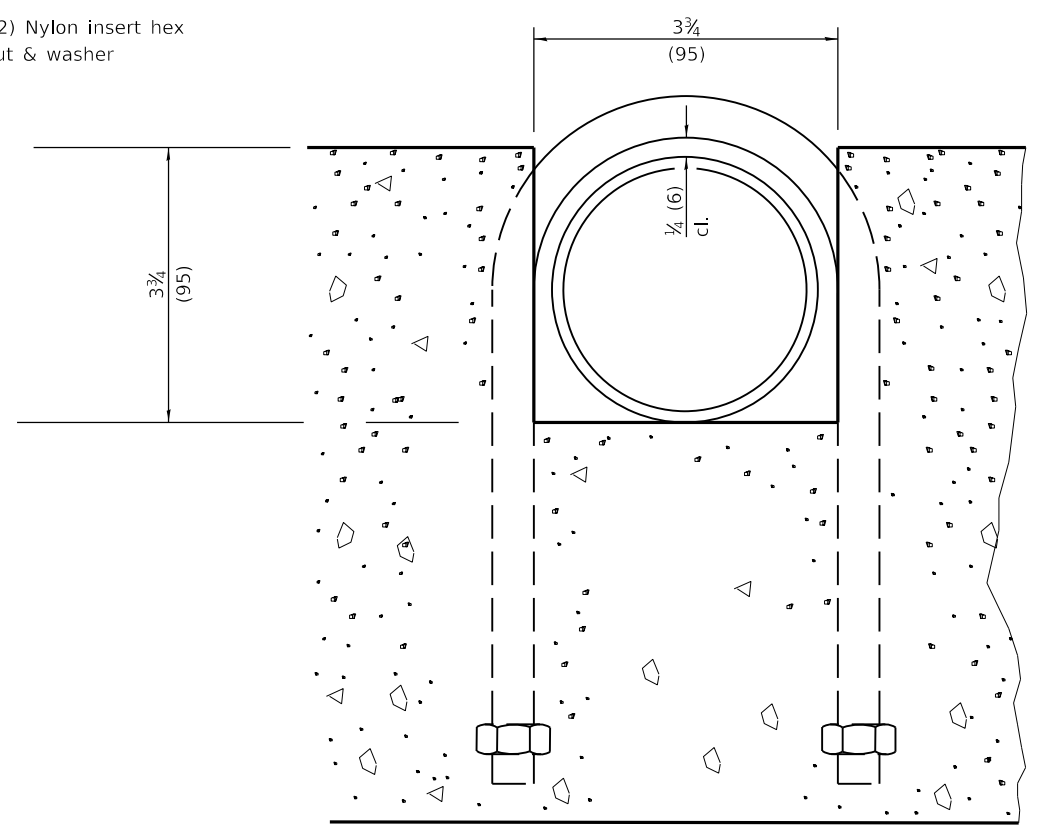

SECTION C-C

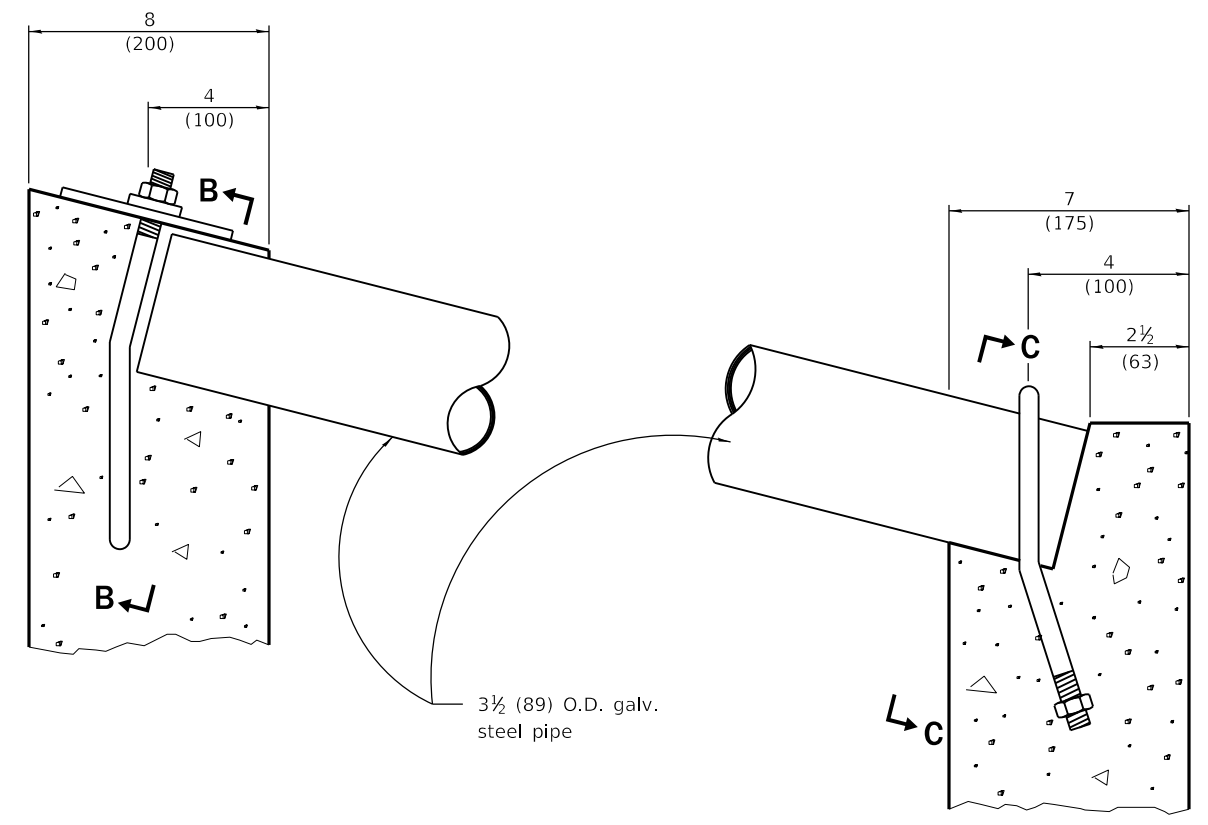

DETAIL AT BLOCKOUTS

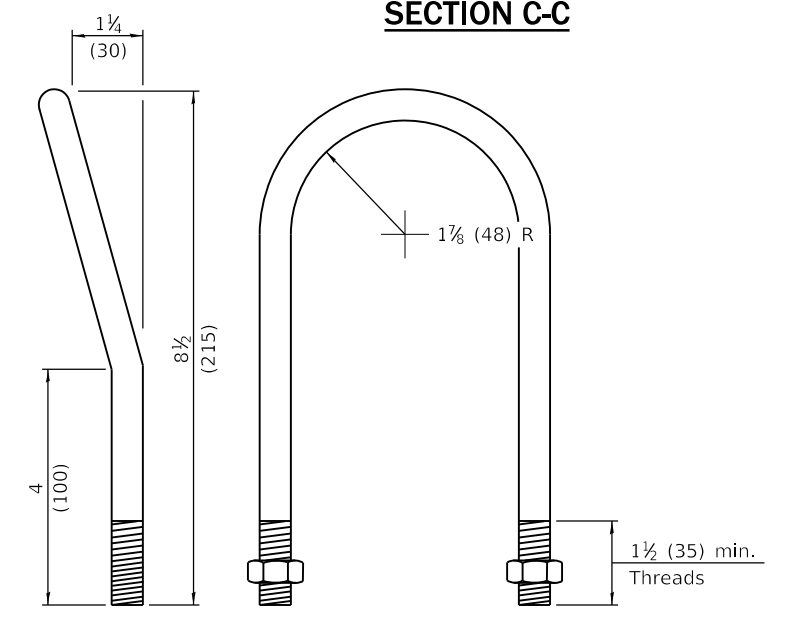

1/2 (M12) U BOLT
(2 - required)

Illinois Department of Transportation
 PASSED January 1, 2009
 ENGINEER OF POLICY AND PROCEDURES
 APPROVED January 1, 2009
 ENGINEER OF DESIGN AND ENVIRONMENT

ISSUED 1-1-97

INLET BOX
TYPE 24 (600) C
 (Sheet 2 of 2)
STANDARD 542511-02

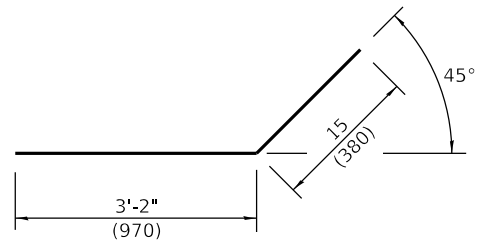

Bar h1

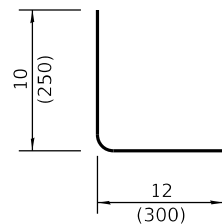

Bar L

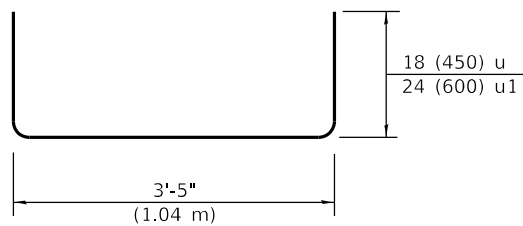

Bar u & u1

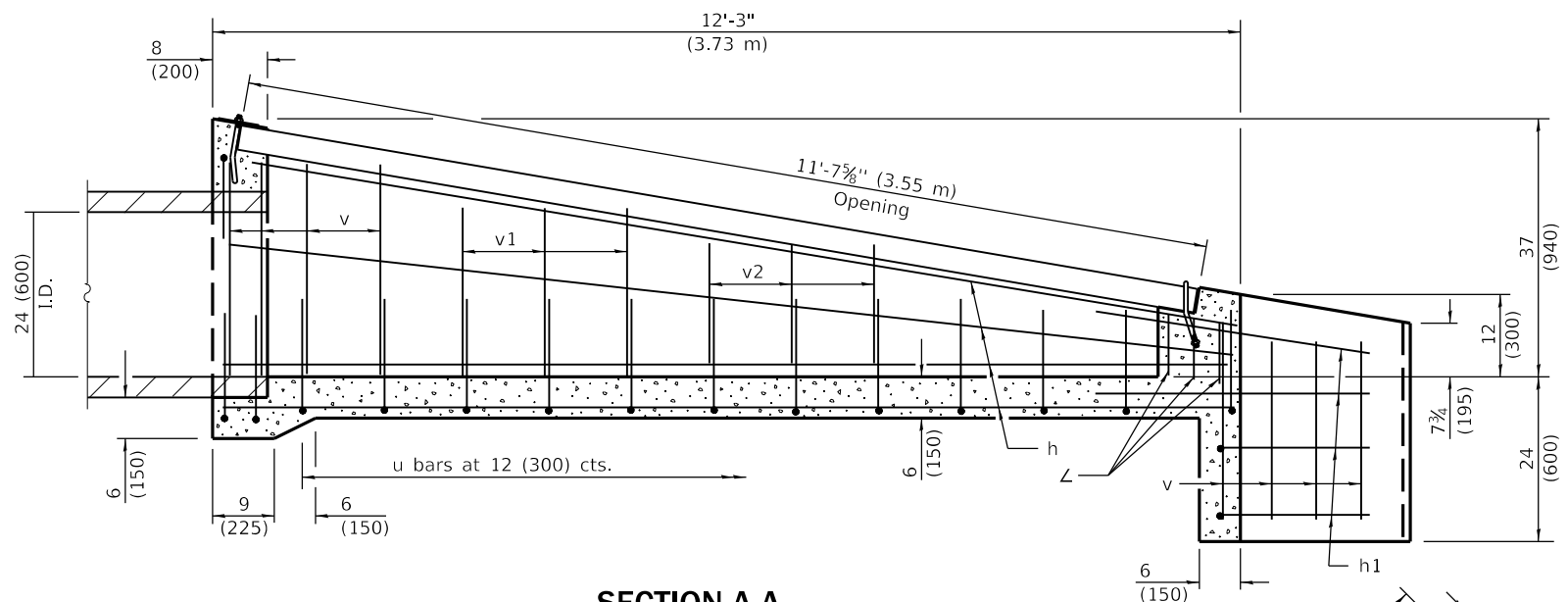

SECTION A-A

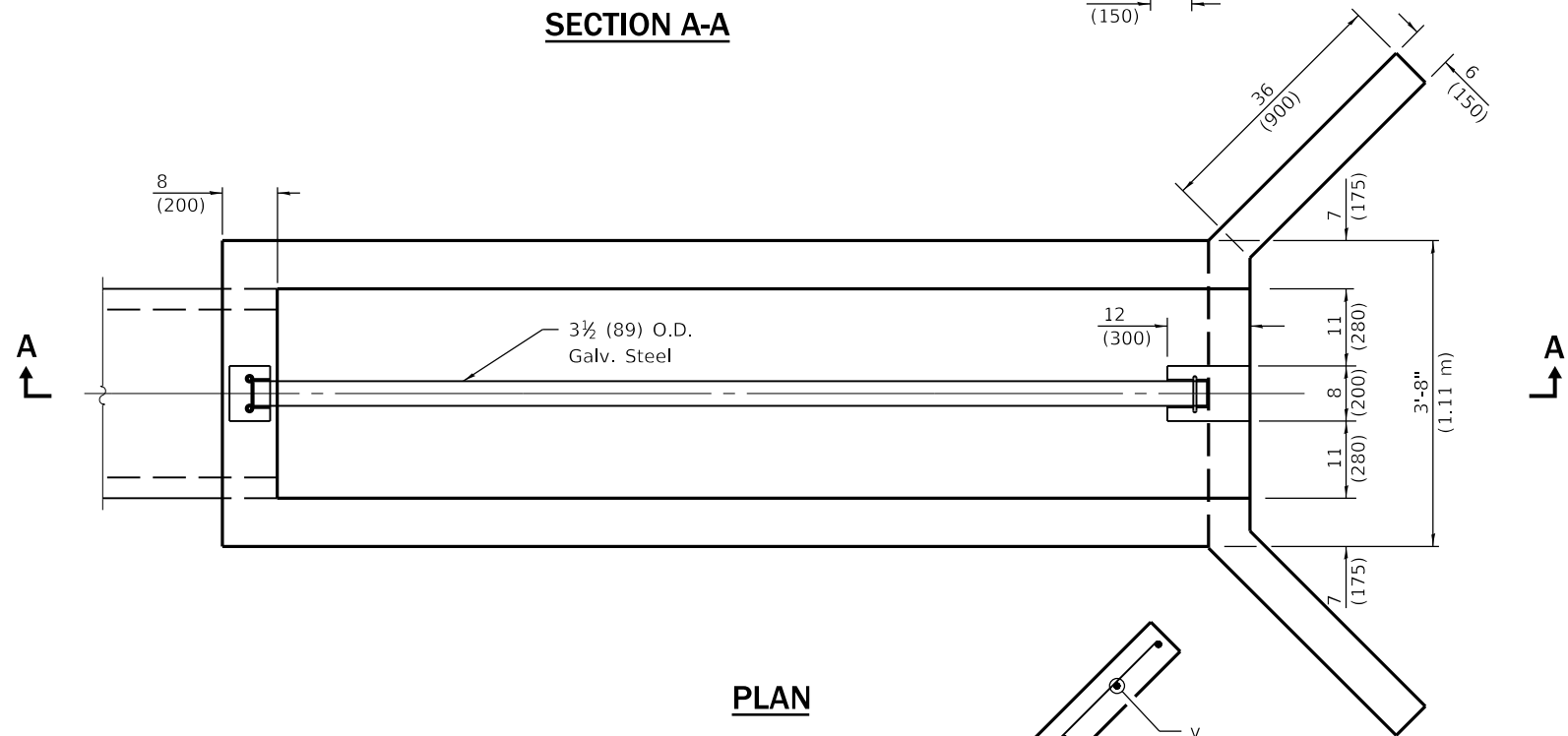

PLAN

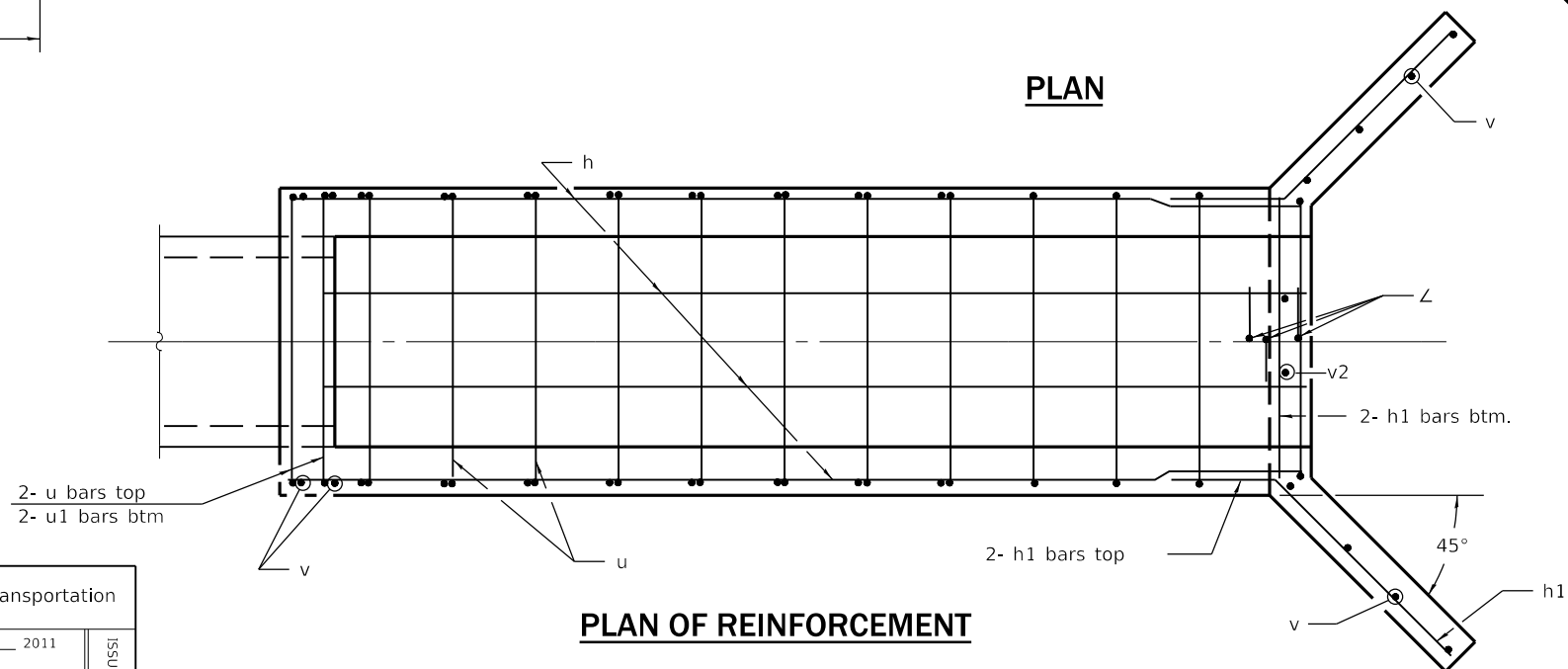

PLAN OF REINFORCEMENT

Material required for one inlet box

Bar	Qty.	Size	Length
h	10	No. 4 (No. 13)	12'-0" (3.66 m)
h1	8	No. 4 (No. 13)	4'-5" (1.35 m)
L	3	No. 4 (No. 13)	22 (550)
u	14	No. 4 (No. 13)	6'-5" (1.94 m)
u1	2	No. 4 (No. 13)	7'-5" (2.24 m)
v	16	No. 4 (No. 13)	30 (760)
v1	6	No. 4 (No. 13)	24 (610)
v2	8	No. 4 (No. 13)	18 (460)
Concrete		cu. yds. (m ³)	2.2 (1.68)
Reinf. Bars		lbs. (kg)	220 (99.8)
Galv. Steel Pipe		3 1/2 (89) O.D.	11'-7 1/2" (3.55 m)

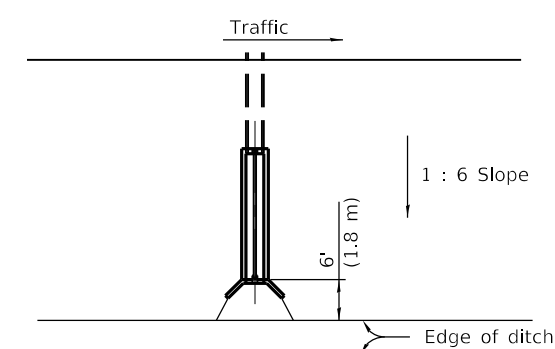

Sketch showing location and direction of box in relation to ditch.

GENERAL NOTES

All slope ratios are expressed as units of vertical displacement to units of horizontal displacement (V:H).

All dimensions are in inches (millimeters) unless otherwise shown.

DATE	REVISIONS
1-1-11	Corrected two bars in weir to 'v2'.
1-1-09	Switched units to English (metric).

**INLET BOX
TYPE 24 (600) D**

(Sheet 1 of 2)

STANDARD 542516-03

Illinois Department of Transportation

PASSED January 1, 2011
Michael Beard
 ENGINEER OF POLICY AND PROCEDURES

APPROVED January 1, 2011
Scott Schick
 ENGINEER OF DESIGN AND ENVIRONMENT

ISSUED 1-1-97

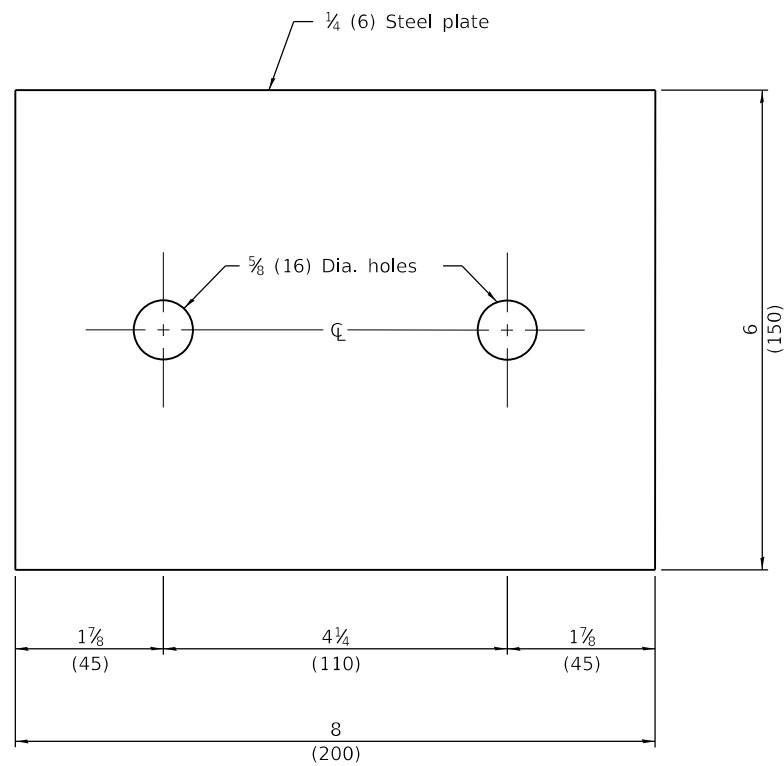

TOP ANCHOR PLATE
(1-required)

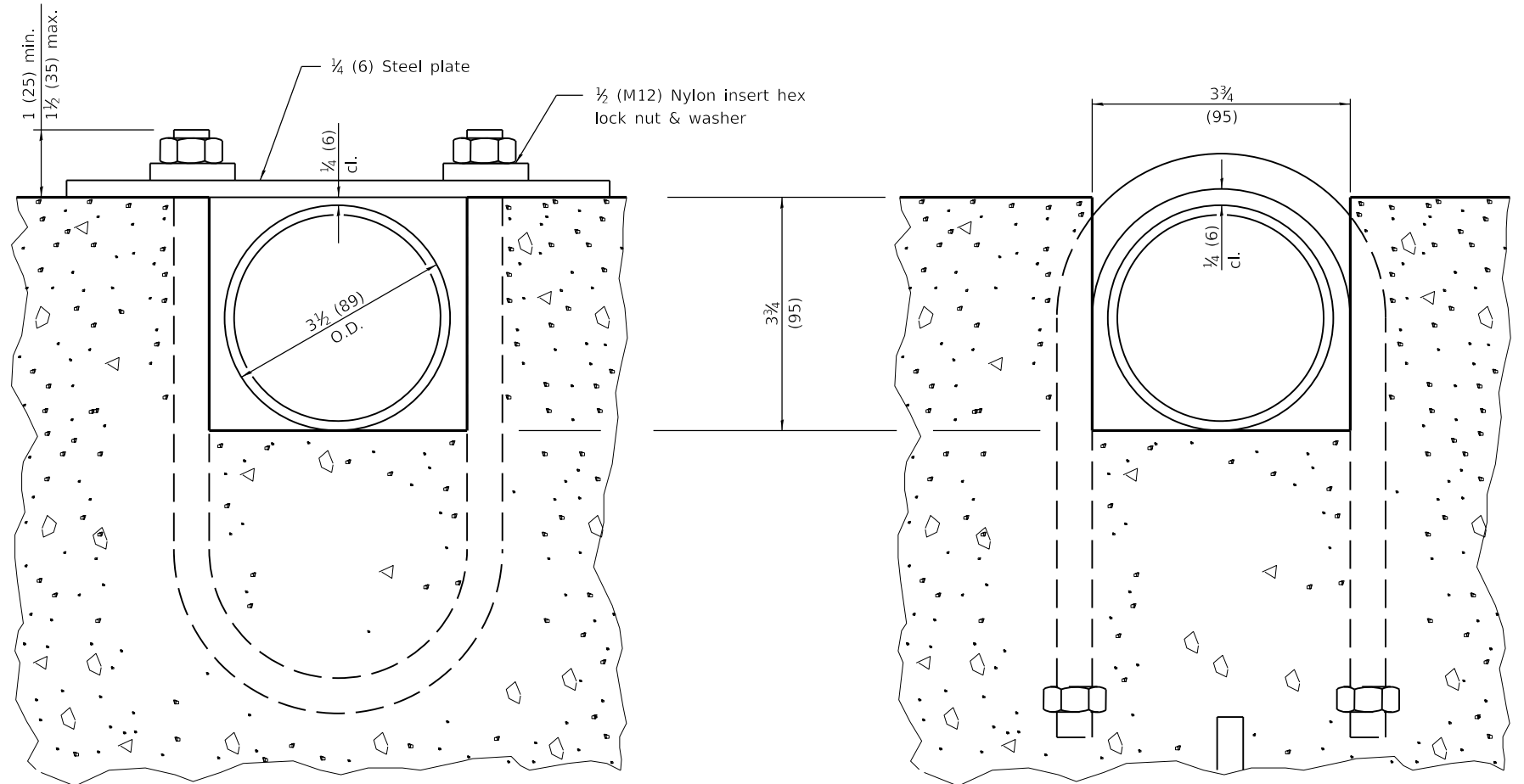

SECTION B-B

SECTION C-C

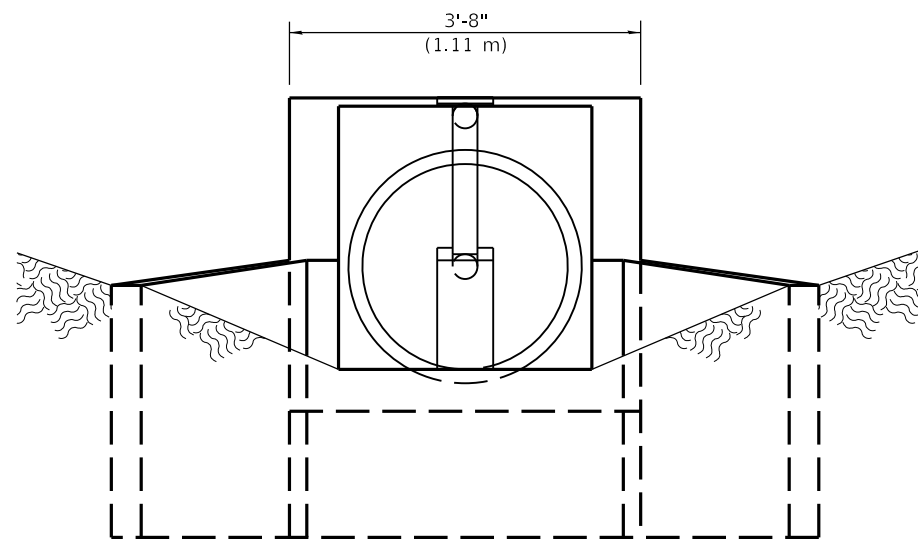

END VIEW

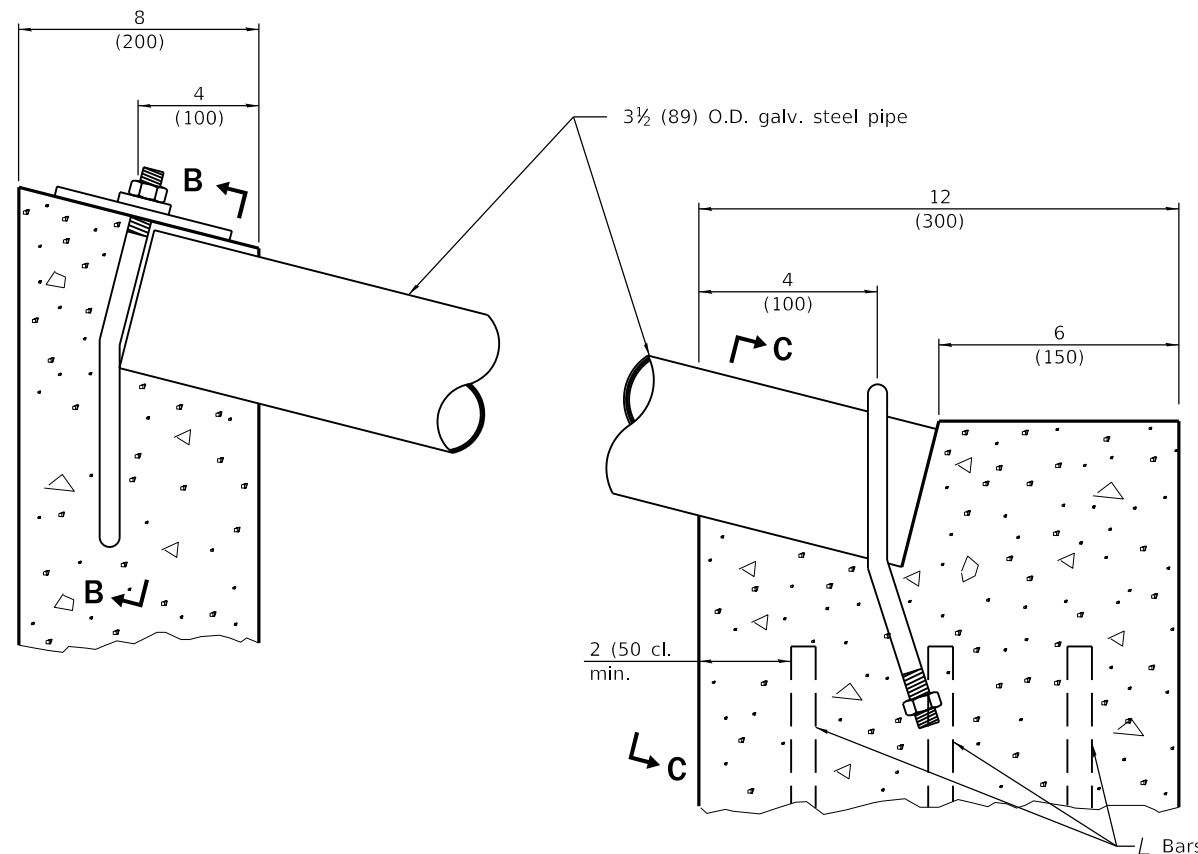

DETAIL AT BLOCKOUTS

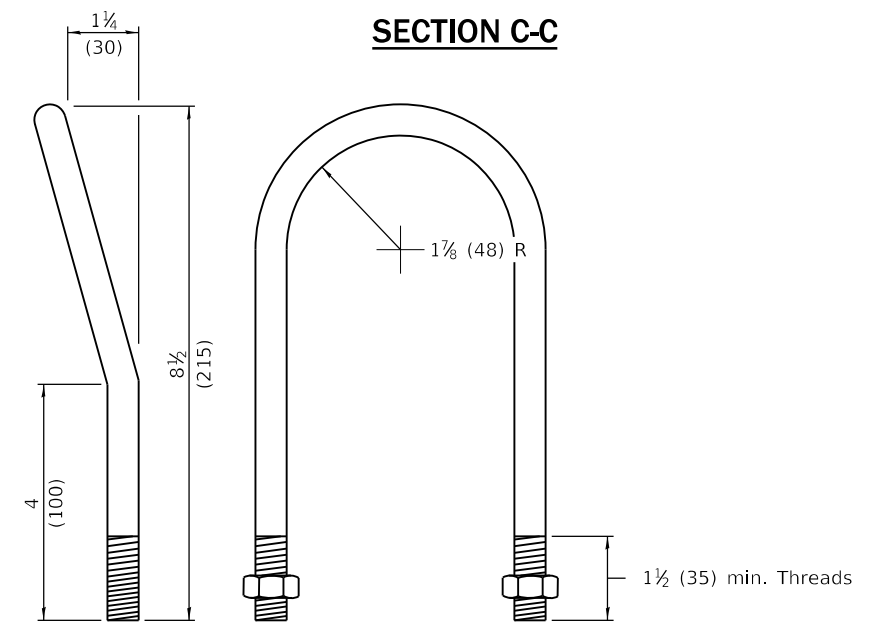

1/2 (M12) U BOLT
(2-required)

**INLET BOX
TYPE 24 (600) D**

(Sheet 2 of 2)

STANDARD 542516-03

	PASSED January 1, 2011 <i>Michael Beard</i> ENGINEER OF POLICY AND PROCEDURES		ISSUED 1-1-97
	APPROVED January 1, 2011 <i>[Signature]</i> ENGINEER OF DESIGN AND ENVIRONMENT		
	PASSED January 1, 2011 <i>[Signature]</i> ENGINEER OF POLICY AND PROCEDURES		
	APPROVED January 1, 2011 <i>[Signature]</i> ENGINEER OF DESIGN AND ENVIRONMENT		

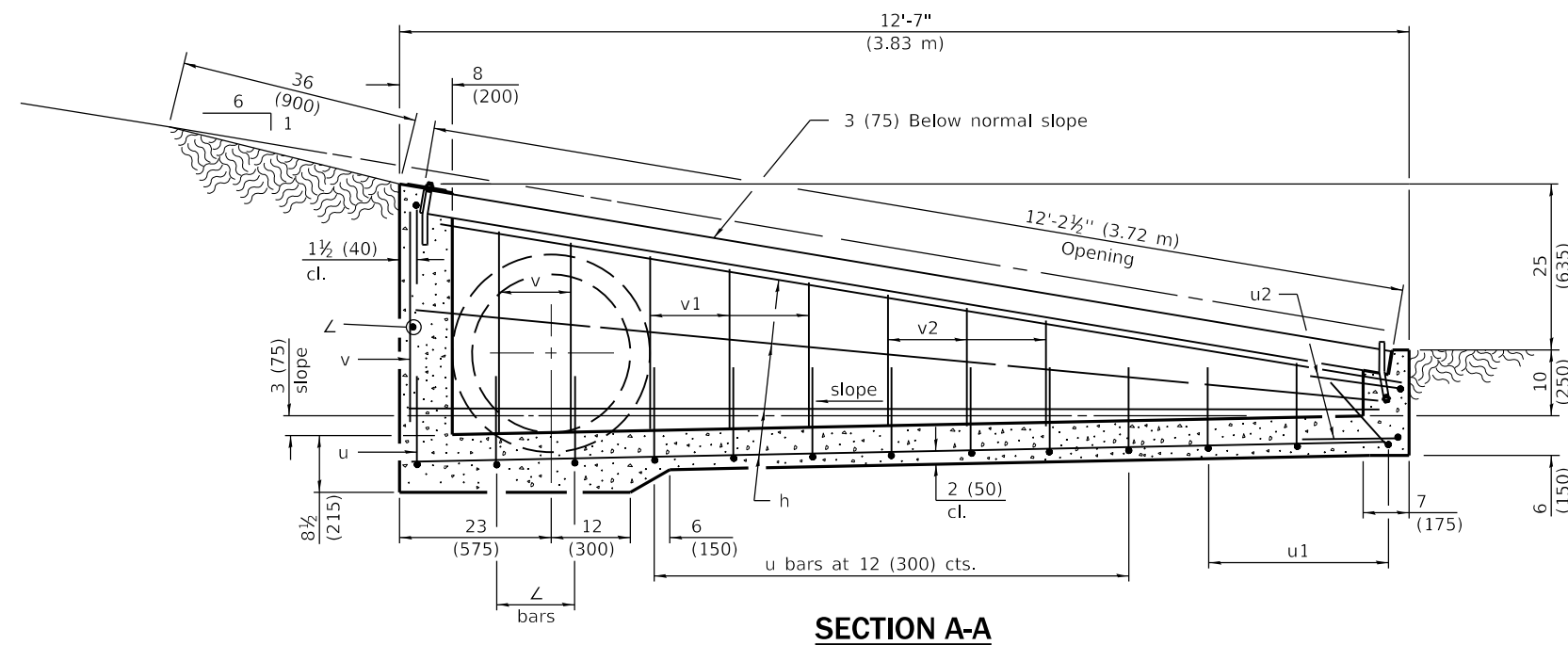

SECTION A-A

Material required for one inlet box

Bar	Qty.	Size	Length
h	8	No. 4 (No. 13)	12'-0" (3.66 m)
h1	2	No. 4 (No. 13)	9'-0" (2.75 m)
L	5	No. 4 (No. 13)	5'-0" (1.50 m)
u	9	No. 4 (No. 13)	6'-5" (1.95 m)
u1	3	No. 4 (No. 13)	5'-11" (1.80 m)
u2	2	No. 4 (No. 13)	5'-10" (1.75 m)
v	6	No. 4 (No. 13)	30 (760)
v1	6	No. 4 (No. 13)	24 (610)
v2	6	No. 4 (No. 13)	18 (460)
Concrete		cu. yds. (m ³)	2.0 (1.5)
Reinforcement Bars		lbs. (kg)	175 (79.4)
Galv. Steel Pipe		3 1/2 (89) O.D.	12'-2 1/4" (3.71 m)

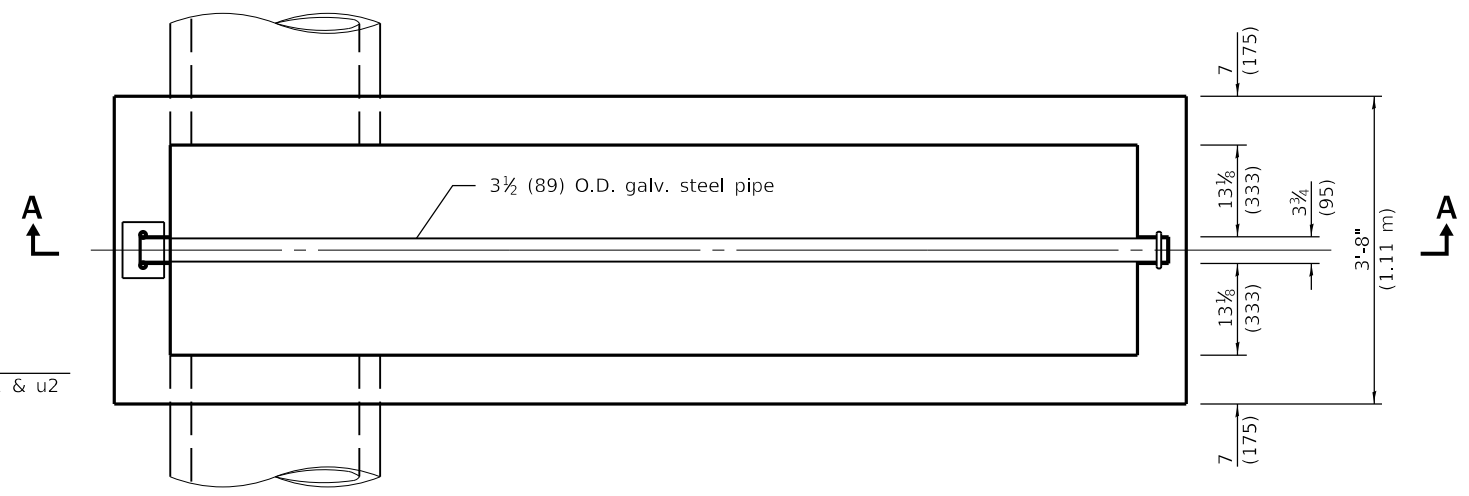

PLAN

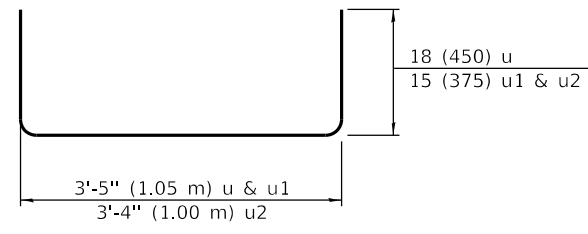

Bars u, u1 & u2

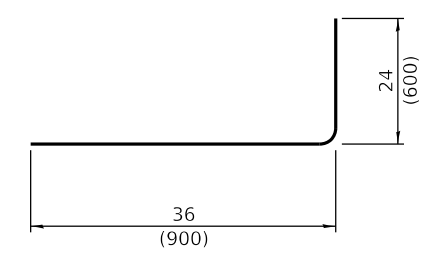

Bar L

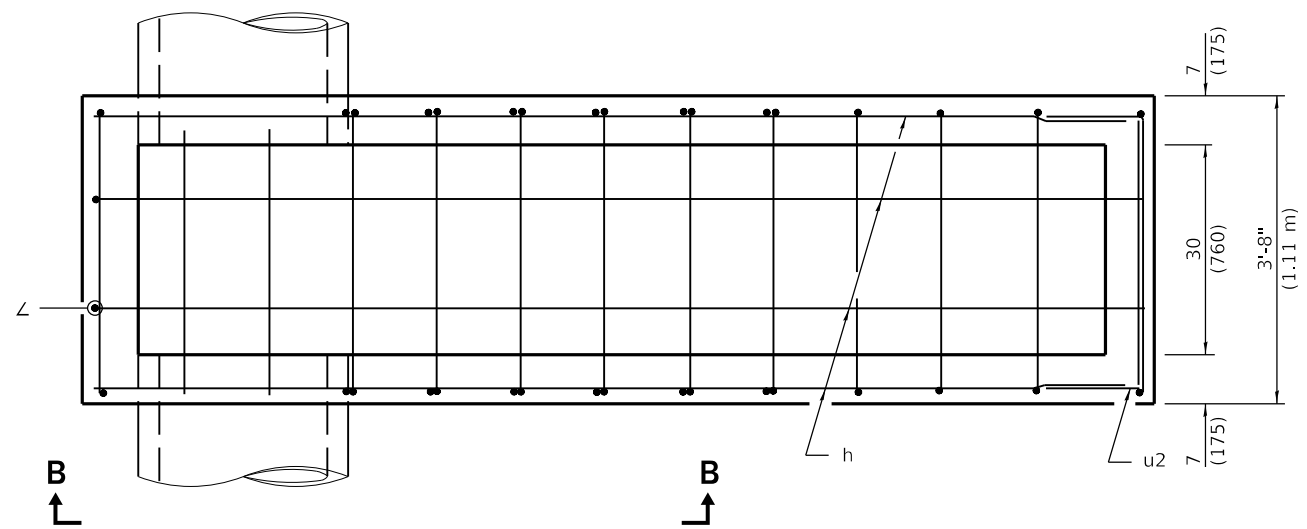

PLAN OF REINFORCEMENT

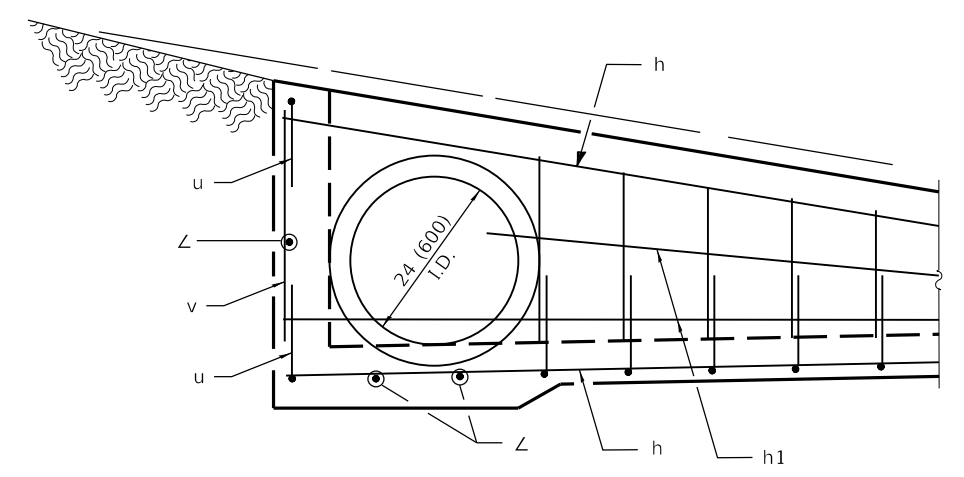

SECTION B-B

GENERAL NOTES

All slope ratios are expressed as units of vertical displacement to units of horizontal displacement (V:H).

All dimensions are in inches (millimeters) unless otherwise shown.

DATE	REVISIONS
1-1-09	Switched units to English (metric).
1-1-07	Soft converted metric reinforcement bars.

**INLET BOX
TYPE 24 (600) E**

(Sheet 1 of 2)

STANDARD 542521-02

Illinois Department of Transportation

PASSED January 1, 2009

ENGINEER OF POLICY AND PROCEDURES

APPROVED January 1, 2009

ENGINEER OF DESIGN AND ENVIRONMENT

ISSUED 46-T-1-03/05

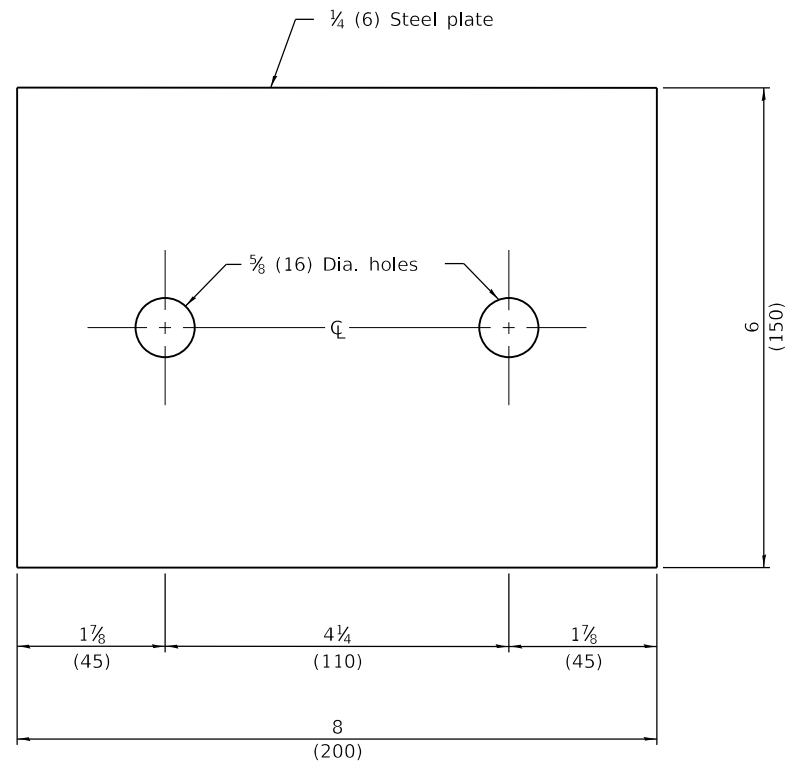

TOP ANCHOR PLATE
(1 - required)

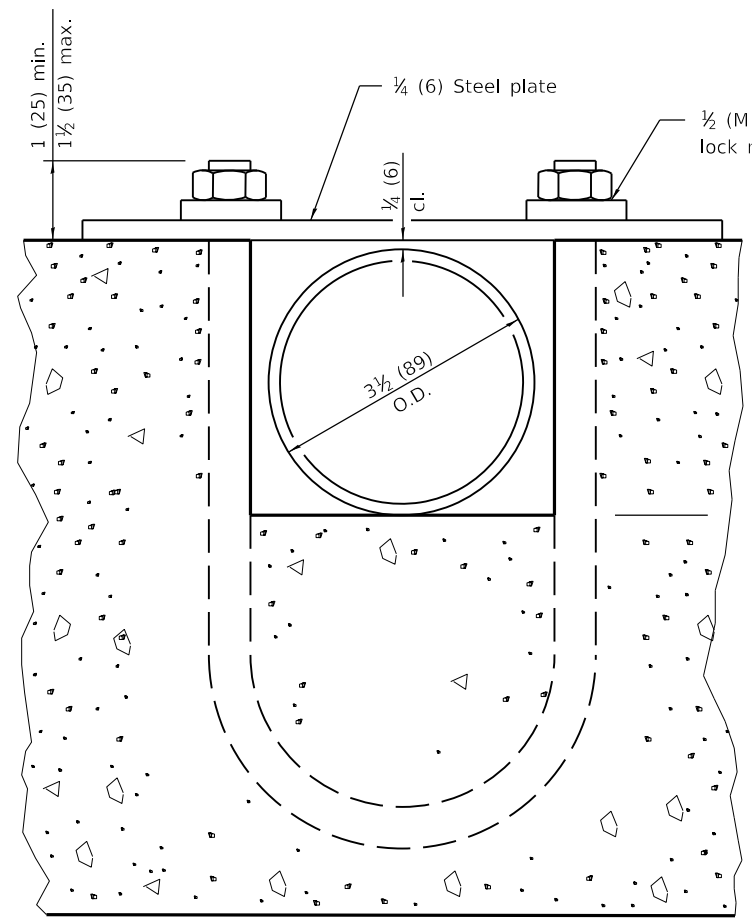

SECTION D-D

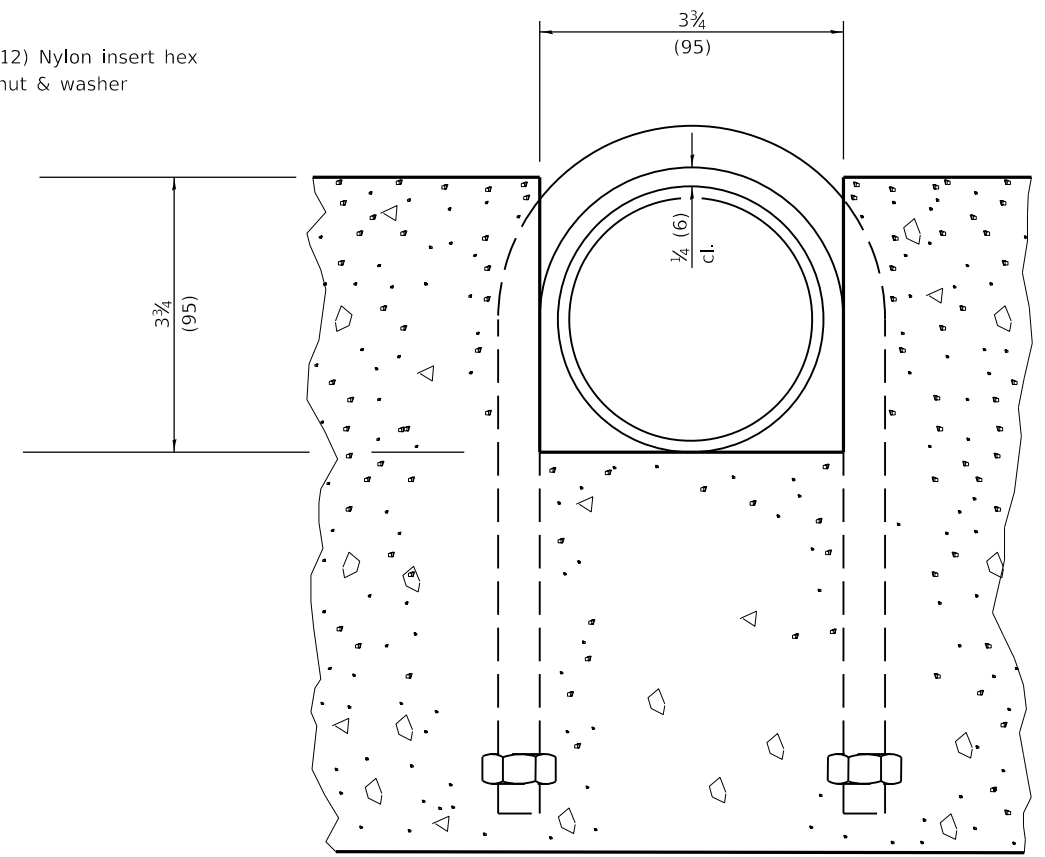

SECTION C-C

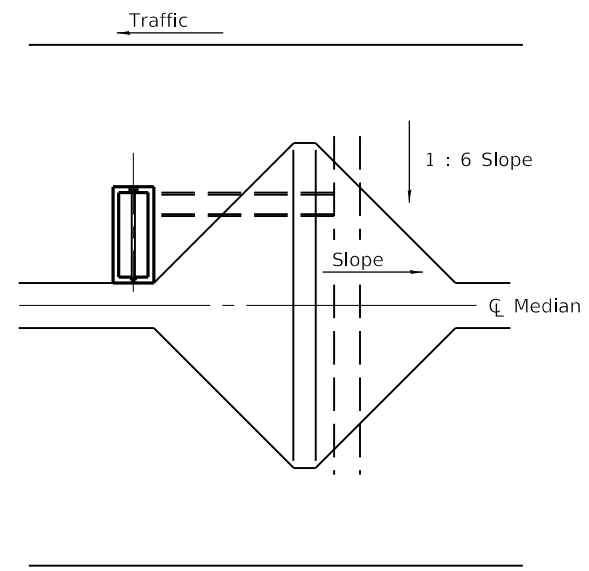

Sketch showing location and direction of box in relation to median.

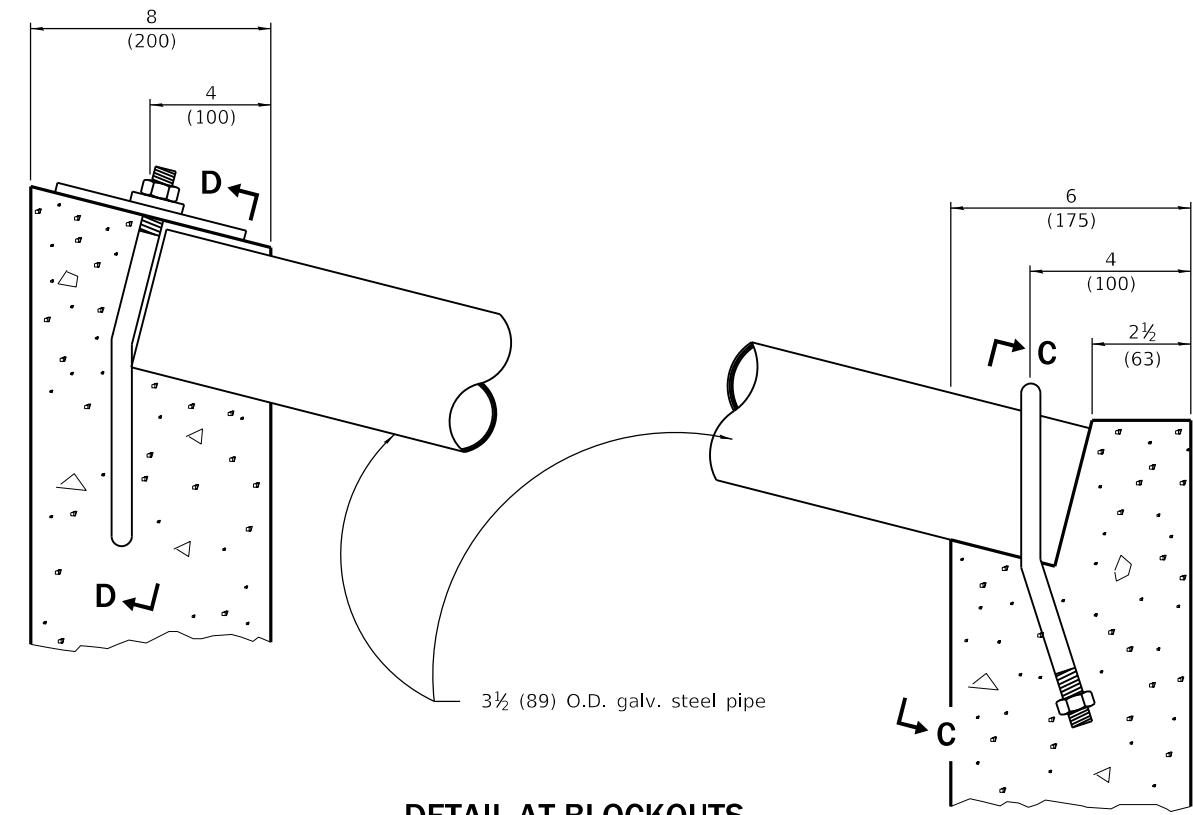

DETAIL AT BLOCKOUTS

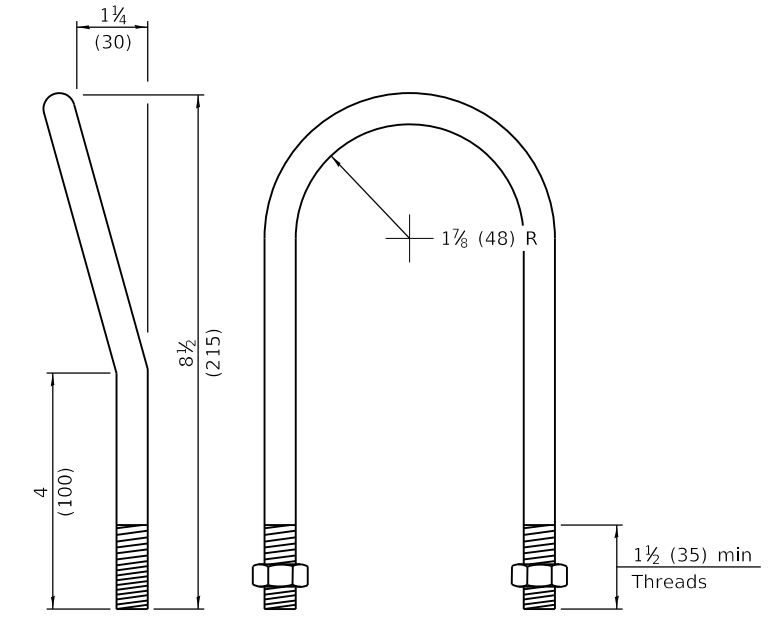

1/2 (M12) U BOLT
(2- required)

**INLET BOX
TYPE 24 (600) E**

(Sheet 2 of 2)

STANDARD 542521-02

Illinois Department of Transportation

PASSED January 1, 2009

ENGINEER OF POLICY AND PROCEDURES

APPROVED January 1, 2009

ENGINEER OF DESIGN AND ENVIRONMENT

ISSUED 1-1-97

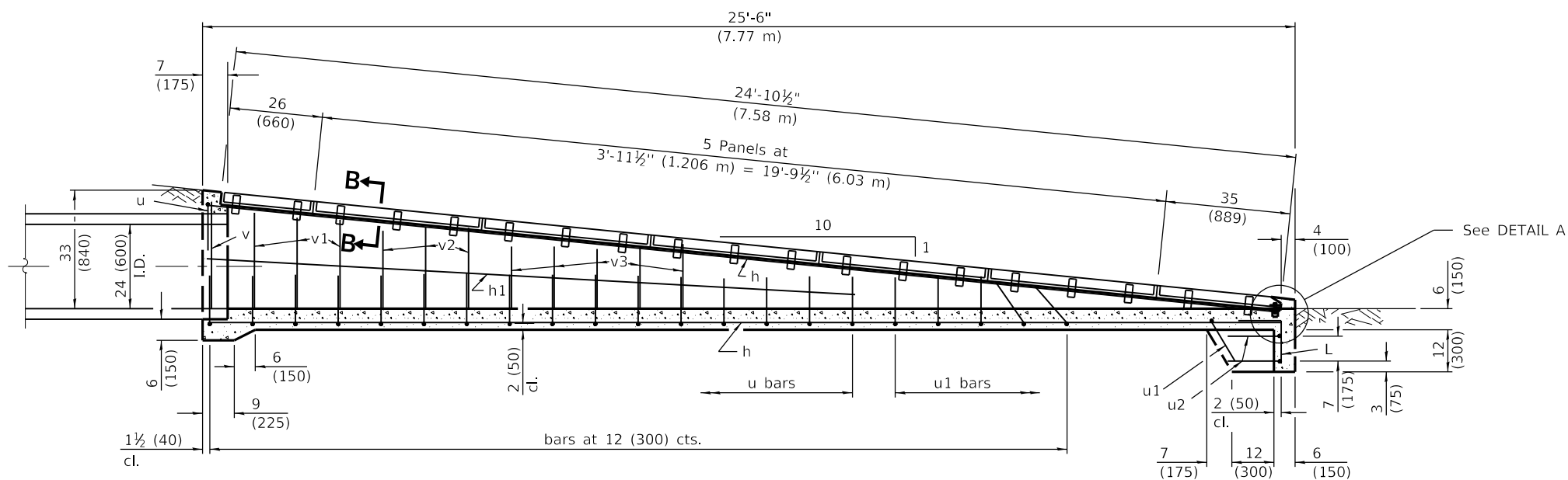

SECTION A-A

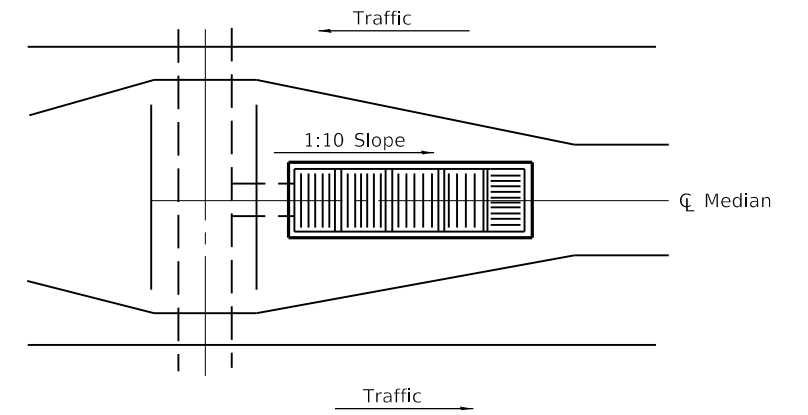

Sketch showing location and direction of main bearing bars in relation to CL median

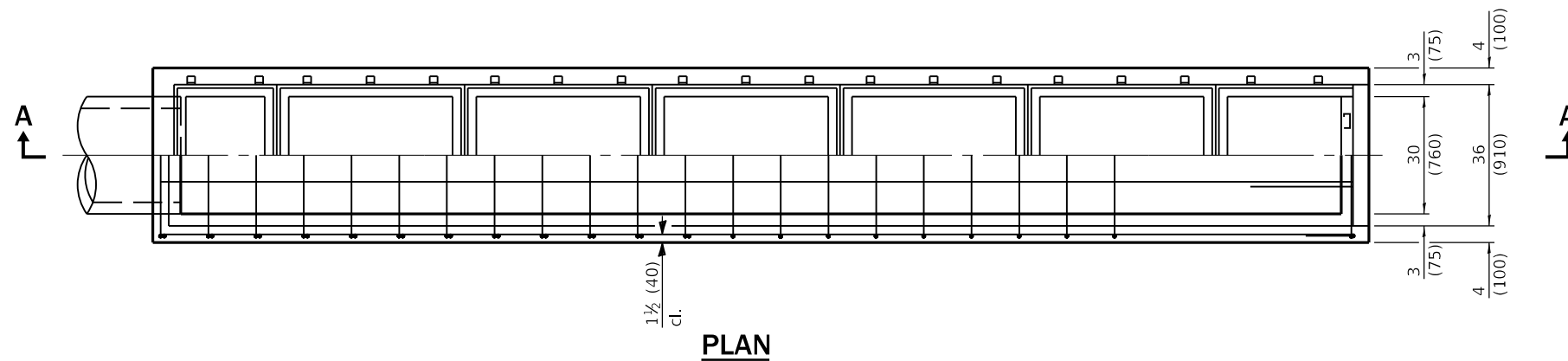

PLAN

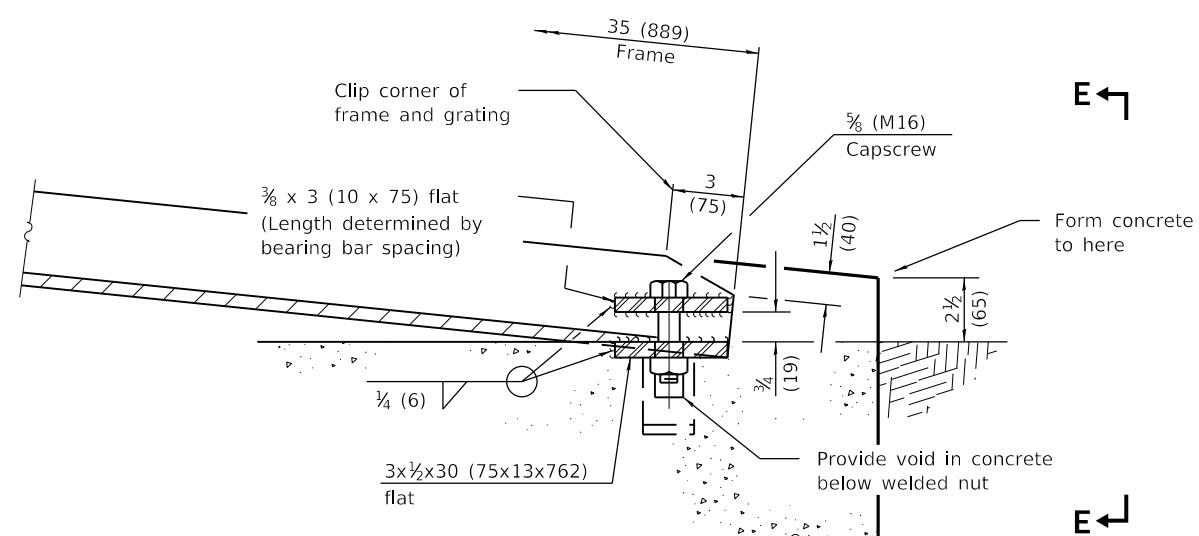

DETAIL A

GENERAL NOTES

If field conditions permit, the bottom of the inlet box shall have a 2 (50) slope.

All slope ratios are expressed as units of vertical displacement to units of horizontal displacement (V:H).

All dimensions are in inches (millimeters) unless otherwise shown.

DATE	REVISIONS
1-1-11	Corrected weld symbols on Sheet 2.
1-1-09	Switched units to English (metric). Revised General Notes.

**INLET BOX
TYPE 24 (600) F**

(Sheet 1 of 2)

STANDARD 542526-03

Illinois Department of Transportation

PASSED January 1, 2011
Michael Beard
 ENGINEER OF POLICY AND PROCEDURES

APPROVED January 1, 2011
[Signature]
 ENGINEER OF DESIGN AND ENVIRONMENT

ISSUED 1-1-97
 76-T

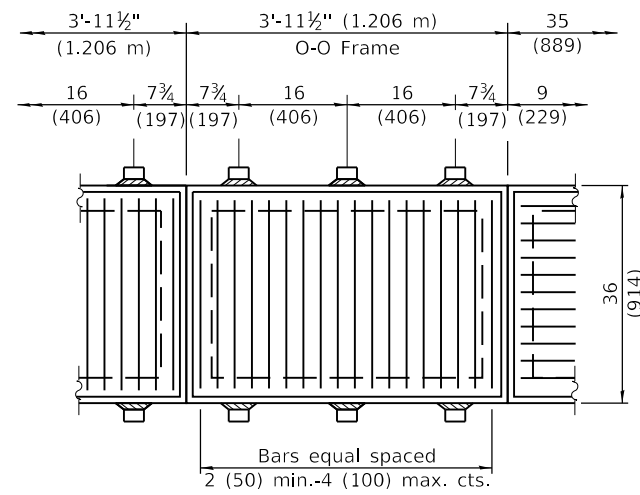

TYPICAL STEEL GRATING

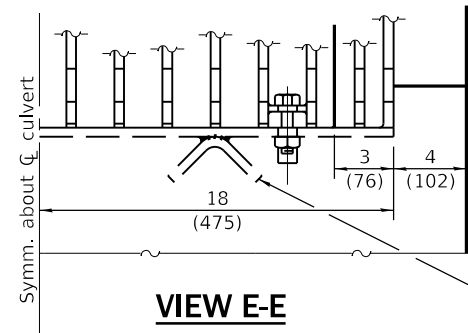

1/2 x 1 1/2 x 5 (12.7 x 40 x 125)
1/4 (6) cfw to 1/2 x 3 (12.7 x 75) flat

Material Required for One Inlet Box

Bar	No.	Size	Length
h	6	No. 4 (No. 13)	25'-0" (7.62 m)
h1	2	No. 4 (No. 13)	11'-0" (3.35 m)
L	4	No. 4 (No. 13)	24 (600)
u	17	No. 4 (No. 13)	6'-5" (1.96 m)
u1	6	No. 4 (No. 13)	5'-11" (1.80 m)
u2	2	No. 4 (No. 13)	5'-10" (1.78 m)
v	2	No. 4 (No. 13)	30 (760)
v1	6	No. 4 (No. 13)	27 (690)
v2	6	No. 4 (No. 13)	24 (610)
v3	10	No. 4 (No. 13)	18 (460)
Concrete		cu. yds. (m ³)	3.4 (2.6)
Reinf. Bars		lbs. (kg)	250 (113)
Grating		(sq. ft.) (m ²)	70.4 (6.54)

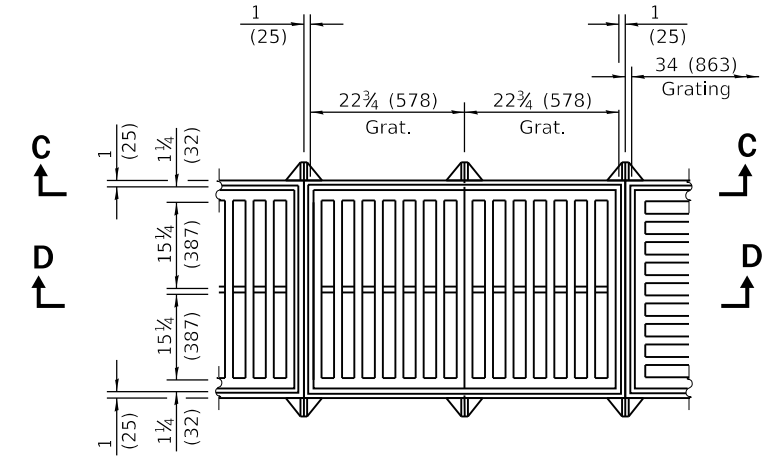

TYPICAL CAST GRATING

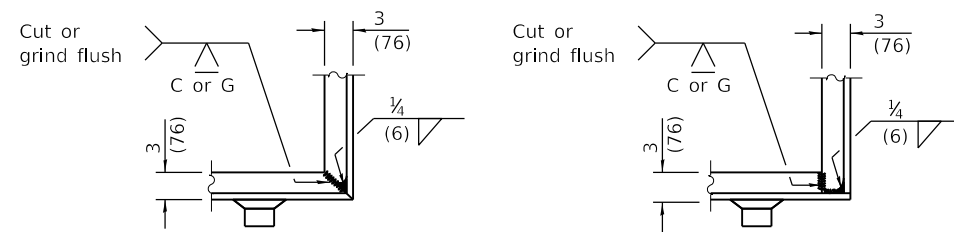

TYPICAL CORNER OF STEEL GRATING FRAME

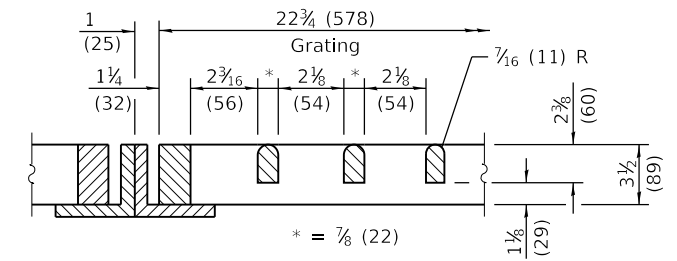

DETAIL B

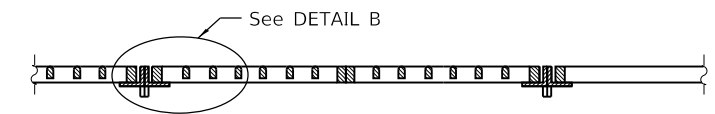

SECTION C-C

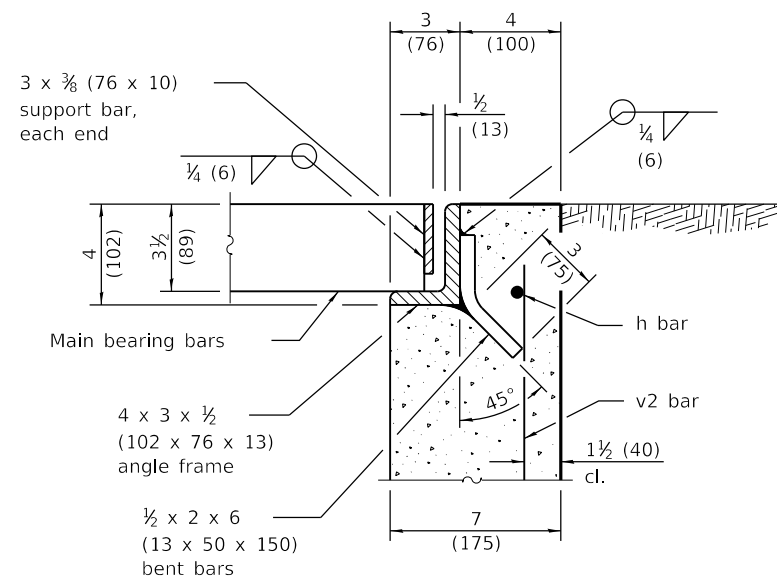

SECTION B-B

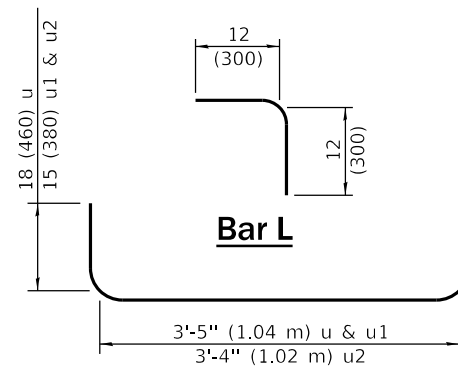

BARS u, u1 & u2

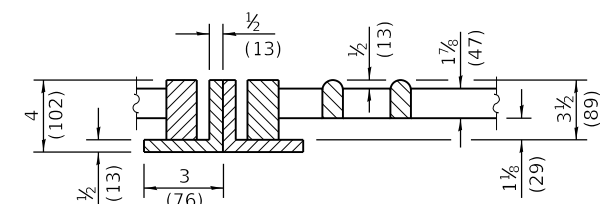

DETAIL C

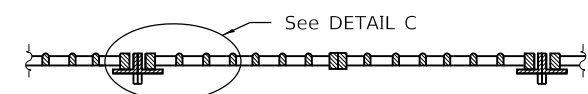

SECTION D-D

**INLET BOX
TYPE 24 (600) F**

(Sheet 2 of 2)

STANDARD 542526-03

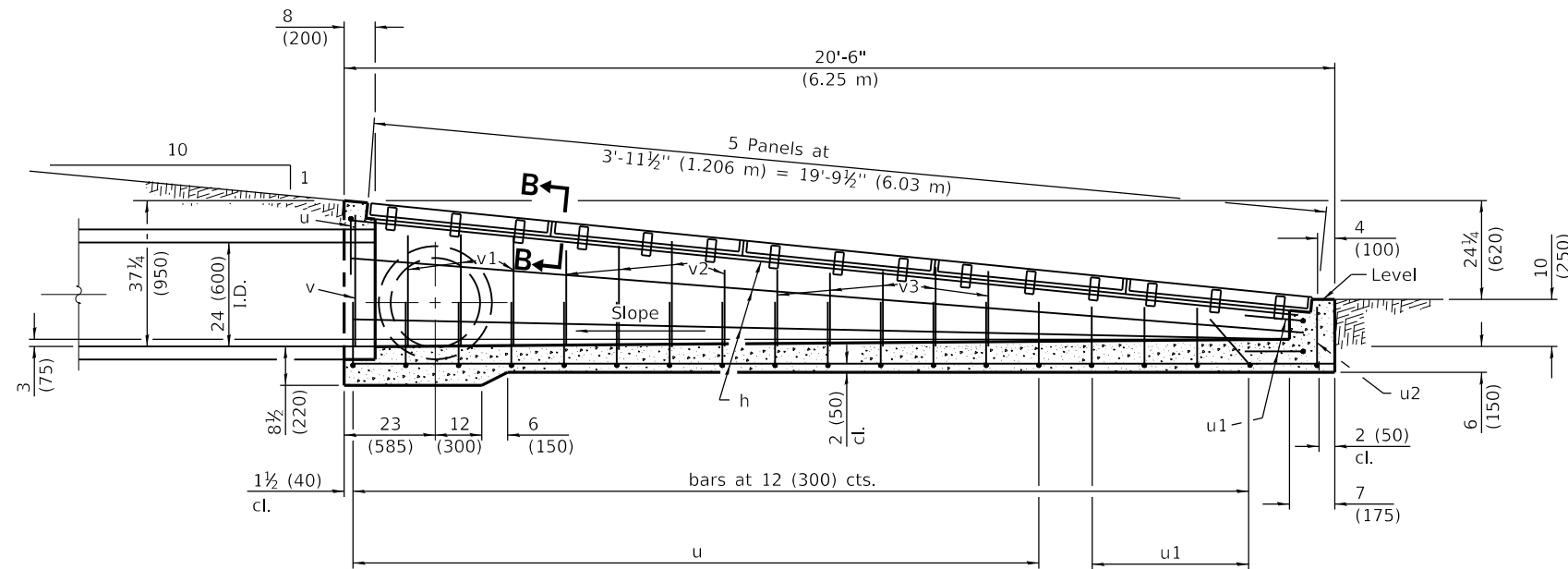

SECTION A-A

NOTE:
Culvert pipe may exit from the side (or sides) by changing reinforcement bars in that area and in the headwall end of box.

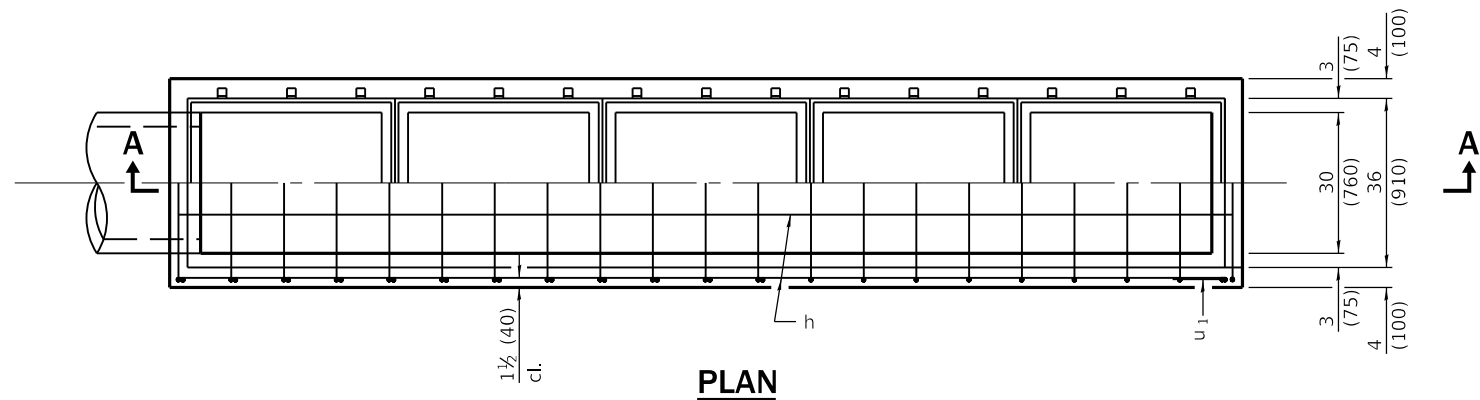

PLAN

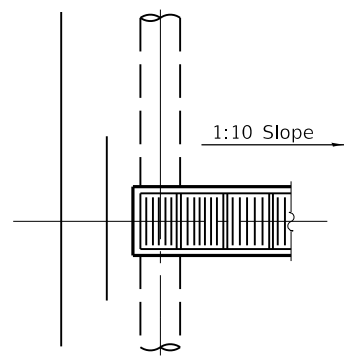

Detail showing exit from side (or sides)

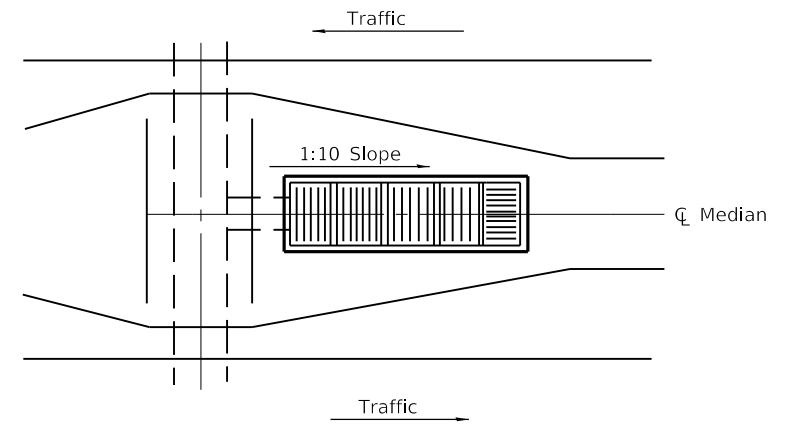

Sketch showing location and direction of main bearing bars in relation to C Median (showing exit from end)

GENERAL NOTES

If field conditions will permit, bottom of inlet box shall have 2 (50) slope.

All slope ratios are expressed as units of vertical displacement to units of horizontal displacement (V:H).

All dimensions are in inches (millimeters) unless otherwise shown.

DATE	REVISIONS
1-1-11	Added 36 (910) dimension to plan view. Corrected weld symbols on Sheet 2.
1-1-09	Switched units to English (metric). Revised General Notes.

**INLET BOX
TYPE 24 (600) G**

(Sheet 1 of 2)

STANDARD 542531-04

Illinois Department of Transportation

PASSED January 1, 2011
Michael Beard
ENGINEER OF POLICY AND PROCEDURES

APPROVED January 1, 2011
Scott Schick
ENGINEER OF DESIGN AND ENVIRONMENT

ISSUED 1-1-97

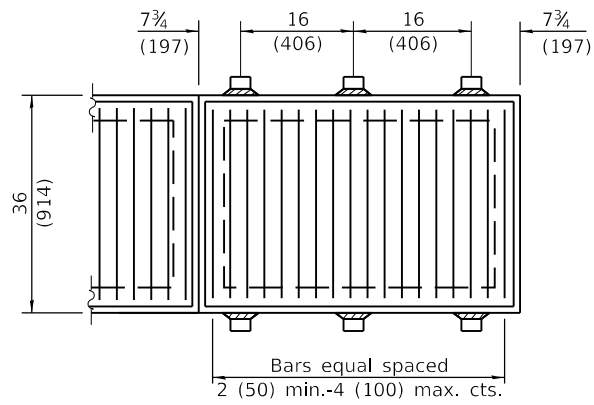

TYPICAL STEEL GRATING

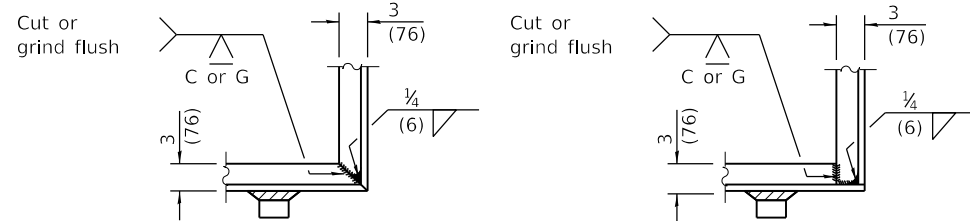

TYPICAL CORNER OF STEEL GRATING FRAME

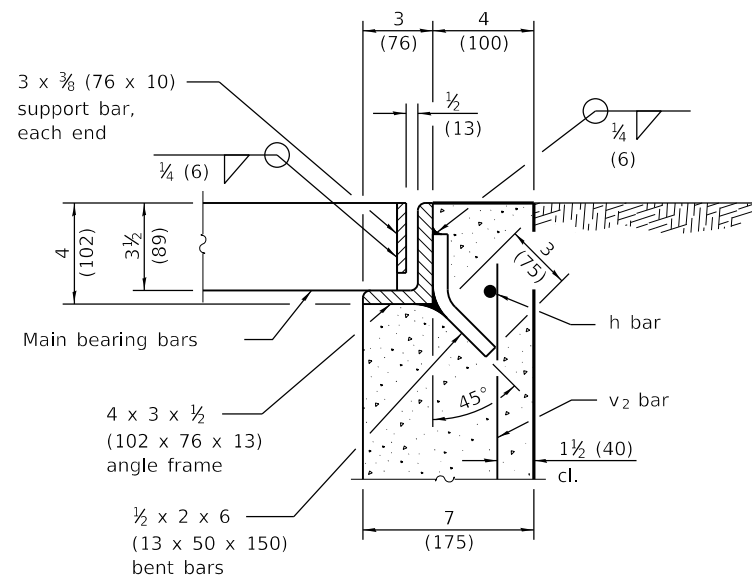

SECTION B-B

Material Required for One Inlet Box

Bar	No.	Size	Length
h	10	No. 4 (No. 13)	20'-0" (6.10 m)
u	17	No. 4 (No. 13)	6'-5" (1.96 m)
u1	6	No. 4 (No. 13)	5'-11" (1.80 m)
u2	1	No. 4 (No. 13)	5'-6" (1.68 m)
v	2	No. 4 (No. 13)	33 (840)
v1	6	No. 4 (No. 13)	30 (760)
v2	10	No. 4 (No. 13)	24 (610)
v3	10	No. 4 (No. 13)	18 (460)
Concrete		cu. yds. (m ³)	3.2 (2.45)
Reinf. Bars		lbs. (kg)	270 (122)
Grating		(sq. ft.) (m ²)	56.0 (5.20)

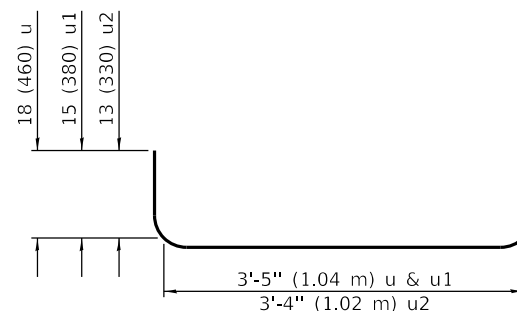

BARS u, u1 & u2

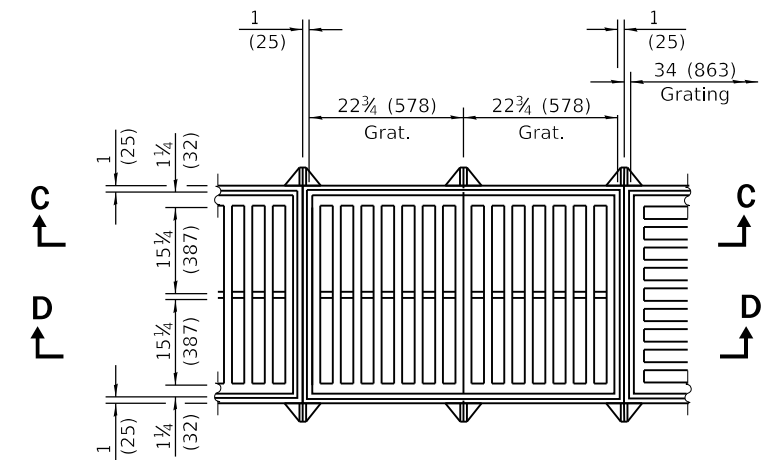

TYPICAL CAST GRATING

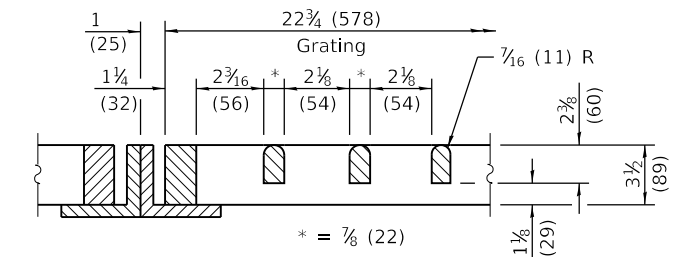

DETAIL B

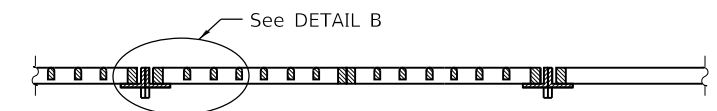

SECTION C-C

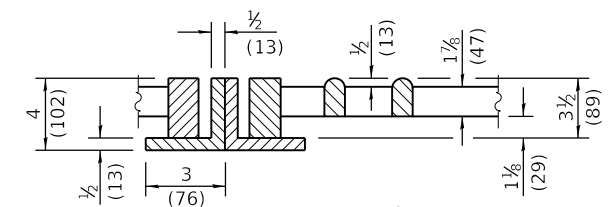

DETAIL C

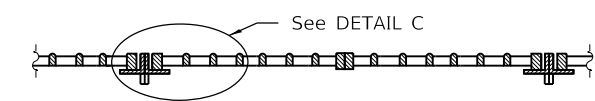

SECTION D-D

Illinois Department of Transportation

PASSED January 1, 2011
Michael Beard
 ENGINEER OF POLICY AND PROCEDURES

APPROVED January 1, 2011
Scott Schick
 ENGINEER OF DESIGN AND ENVIRONMENT

ISSUED 1-1-97

**INLET BOX
TYPE 24 (600) G**

(Sheet 2 of 2)

STANDARD 542531-04

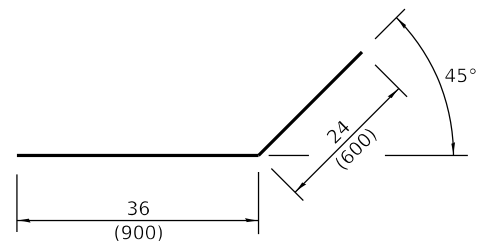

Bar h2

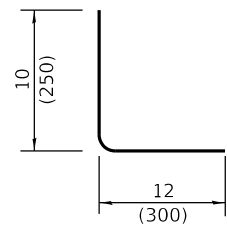

Bar L

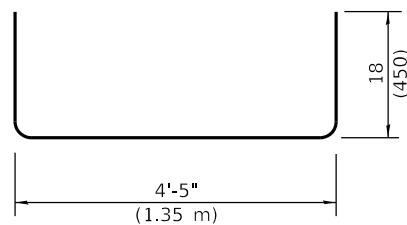

Bar u

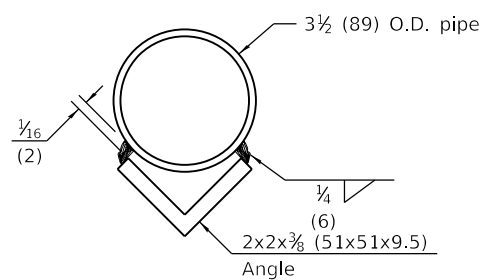

SECTION D-D

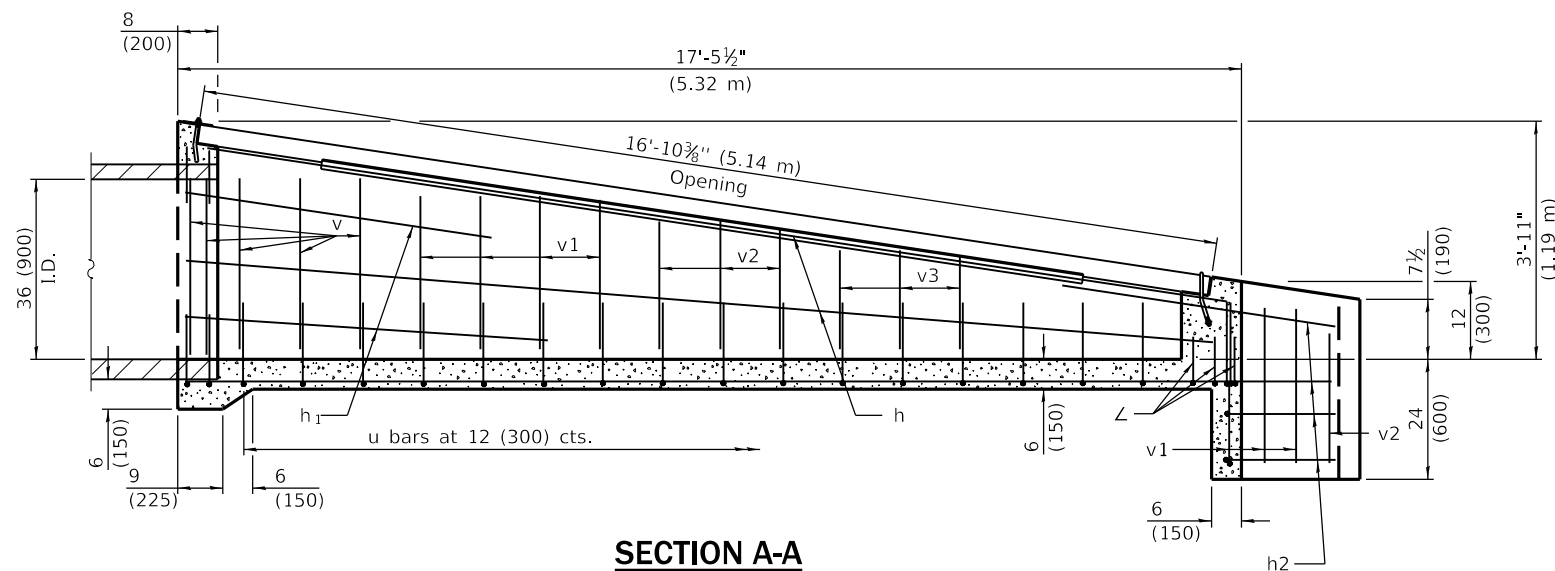

SECTION A-A

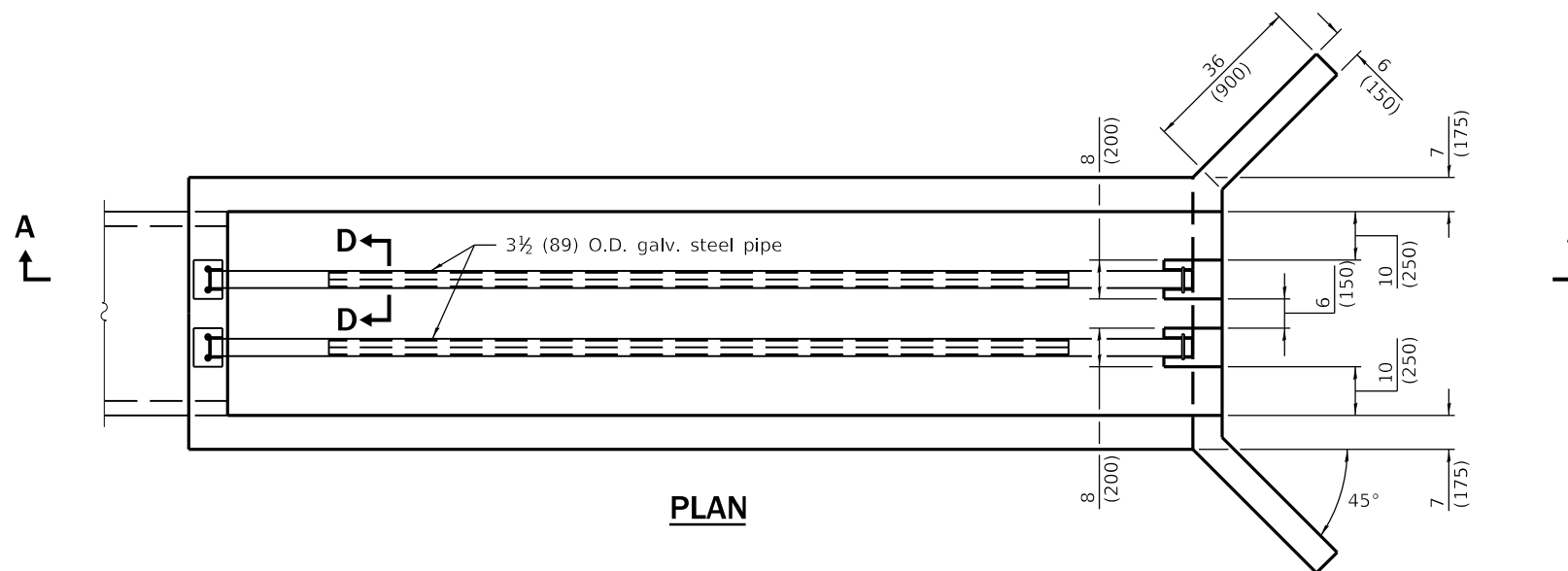

PLAN

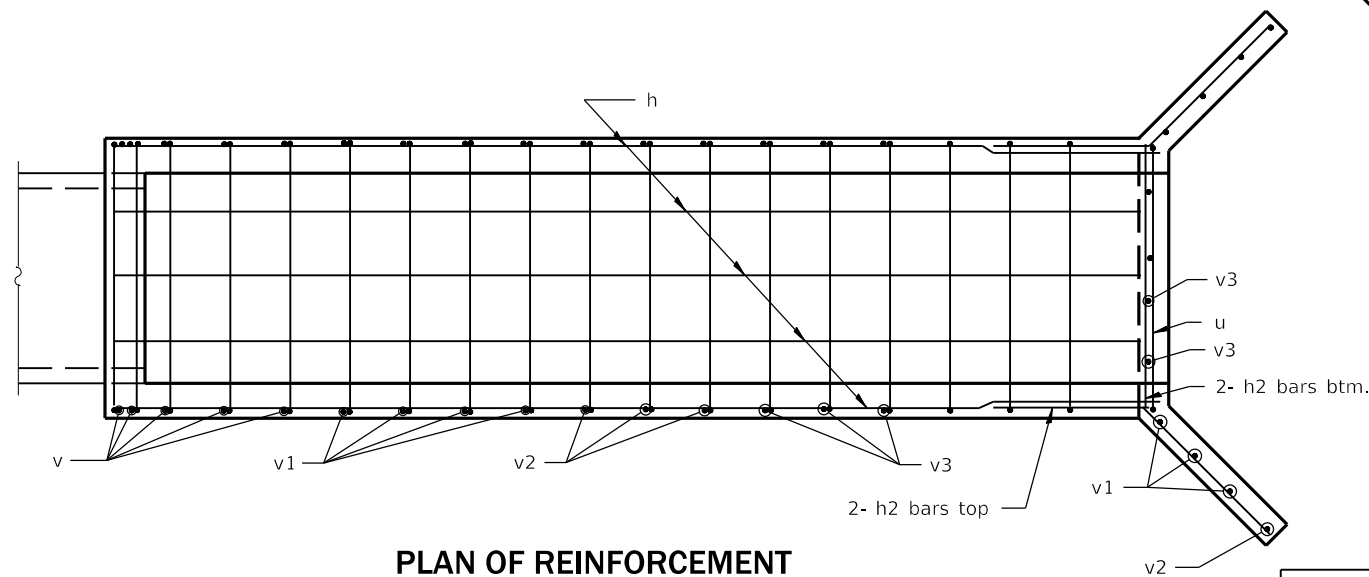

PLAN OF REINFORCEMENT

Material required for one inlet box

Bar	Qty.	Size	Length
h	9	No. 4 (No. 13)	17'-0" (5.18 m)
h1	4	No. 4 (No. 13)	6'-3" (1.90 m)
h2	8	No. 4 (No. 13)	5'-0" (1.50 m)
L	6	No. 4 (No. 13)	22 (550)
u	21	No. 4 (No. 13)	7'-5" (2.25 m)
v	10	No. 4 (No. 13)	36 (910)
v1	14	No. 4 (No. 13)	30 (760)
v2	8	No. 4 (No. 13)	24 (610)
v3	10	No. 4 (No. 13)	18 (460)
Concrete	cu. yds. (m ³)		3.9 (3.0)
Reinf. Bars	lbs. (kg)		319 (145)
Galv. Steel Pipe	3 1/2 (89) O.D.	2 at 16'-10 3/8" (5.15 m)	
Galv. Steel Angle	2x2x3/8 (51x51x9.5)	2 at 12'-10" (3.90 m)	

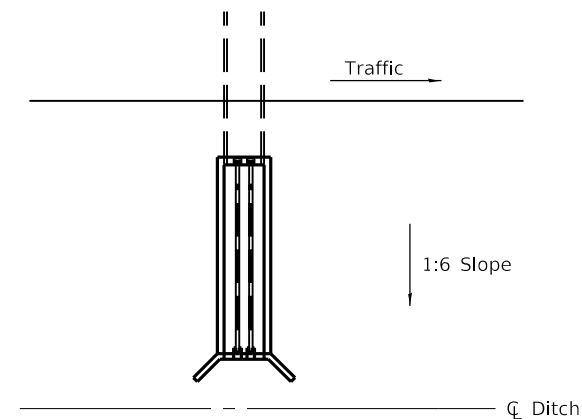

Sketch showing location and direction of box in relation to C of ditch.

GENERAL NOTES

All slope ratios are expressed as units of vertical displacement to units of horizontal displacement (V:H).

All dimensions are in inches (millimeters) unless otherwise shown.

DATE	REVISIONS
1-1-10	Corrected 3'-11" vertical dimension line in Section A-A.
1-1-09	Switched units to English (metric).

**INLET BOX
TYPE 36 (900) A**

(Sheet 1 of 2)

STANDARD 542536-03

Illinois Department of Transportation

PASSED January 1, 2010
[Signature]
 ENGINEER OF POLICY AND PROCEDURES

APPROVED January 1, 2010
[Signature]
 ENGINEER OF DESIGN AND ENVIRONMENT

ISSUED 1-1-97

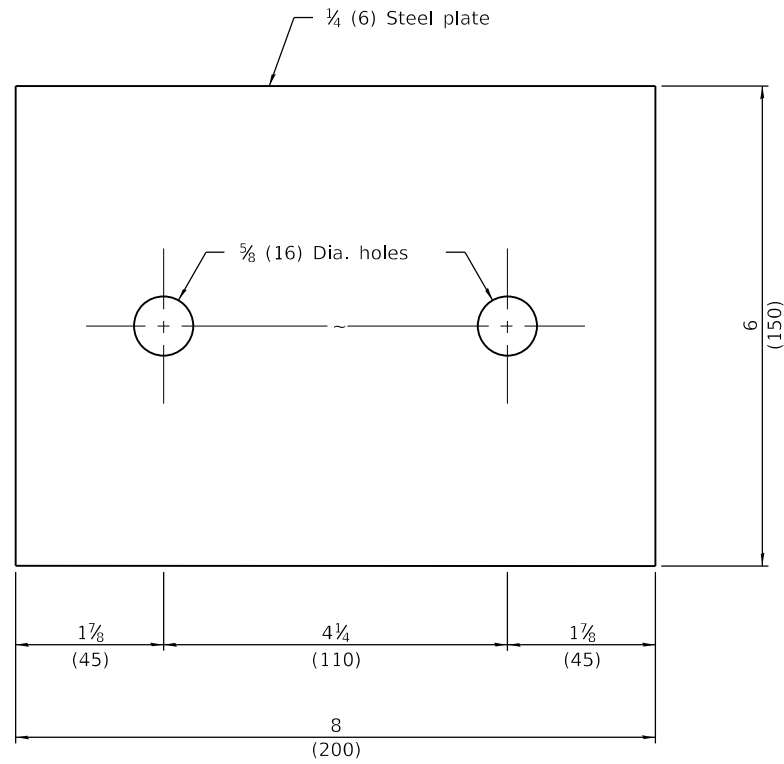

TOP ANCHOR PLATE
(2 - required)

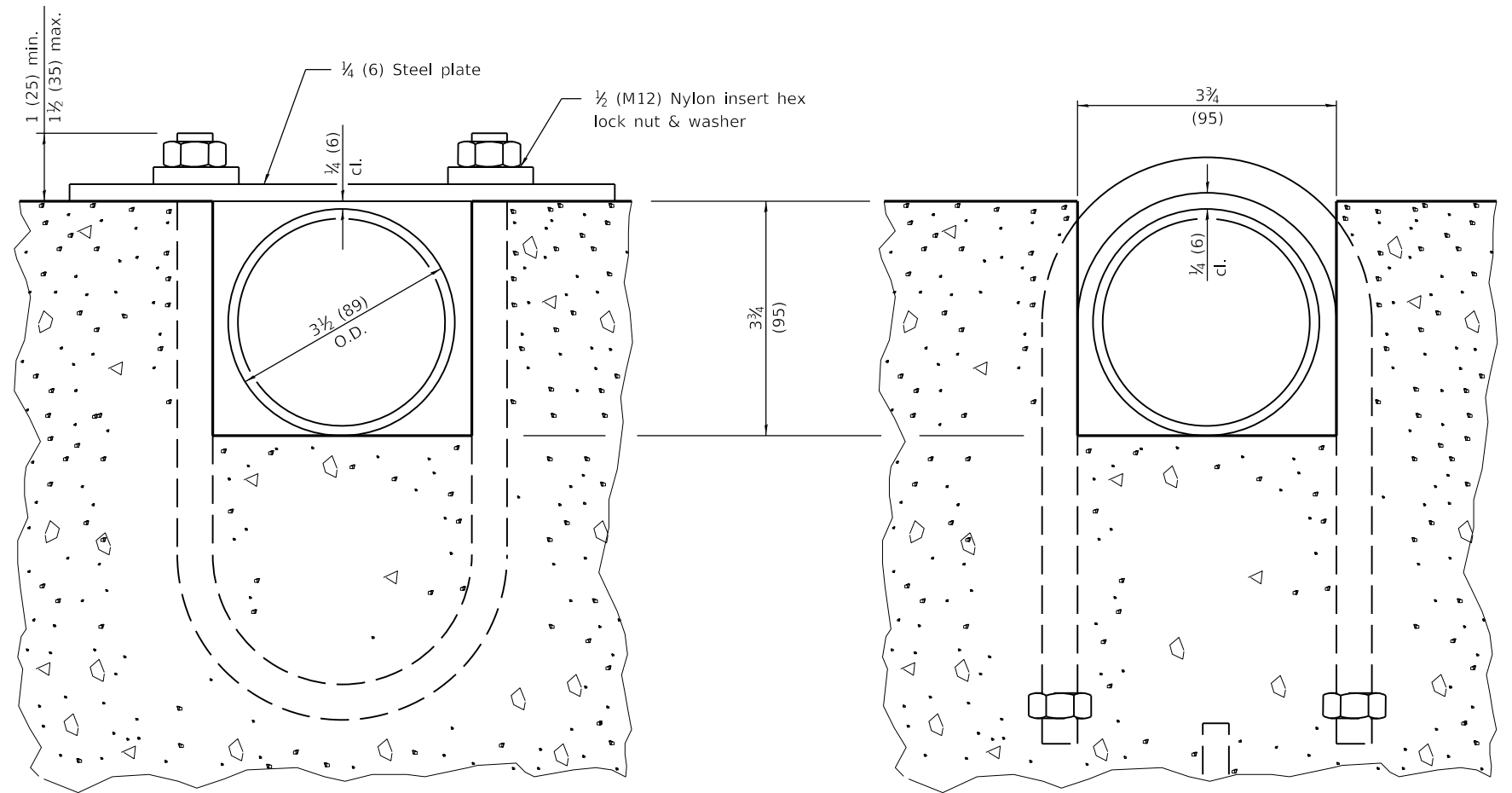

SECTION B-B

SECTION C-C

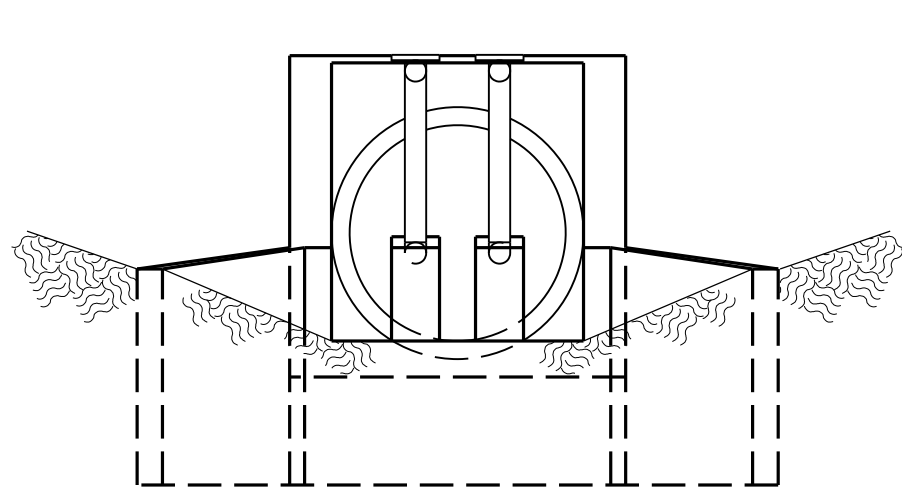

END VIEW

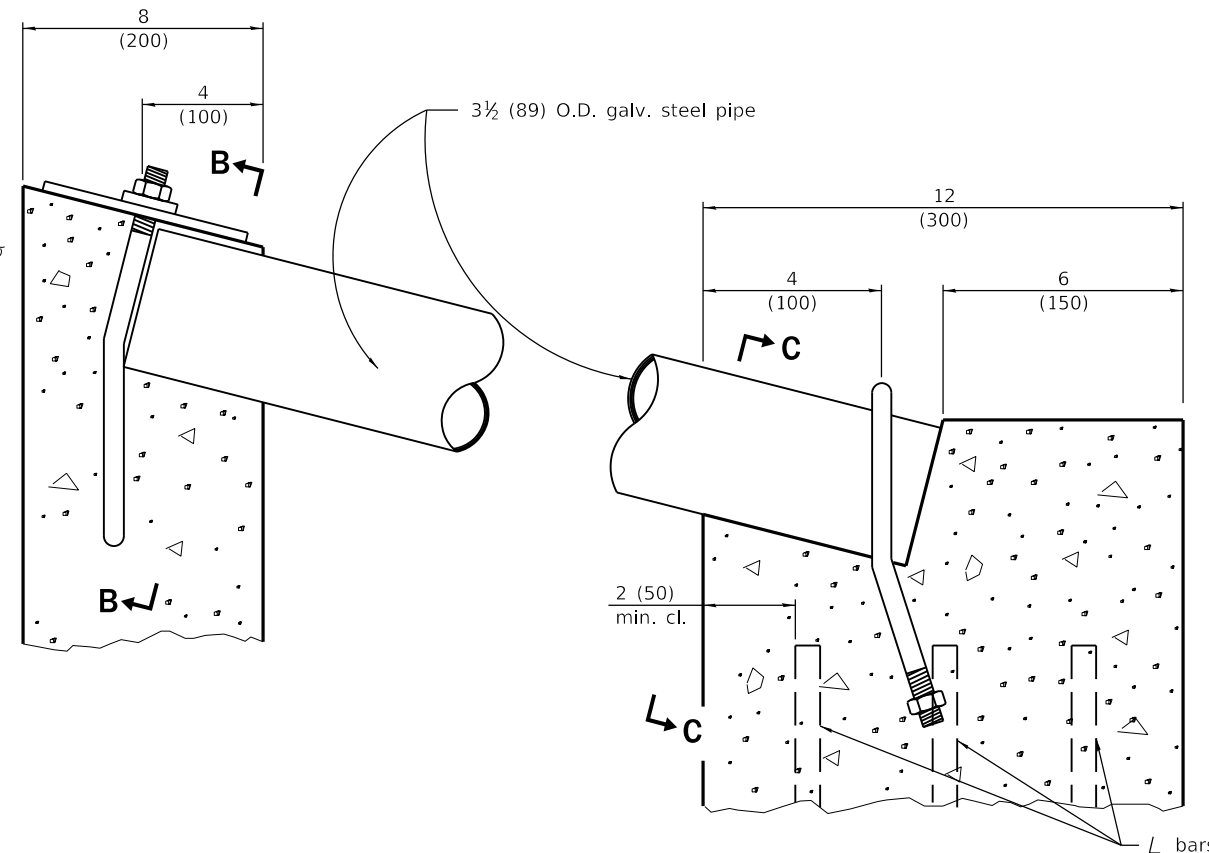

DETAIL AT BLOCKOUTS

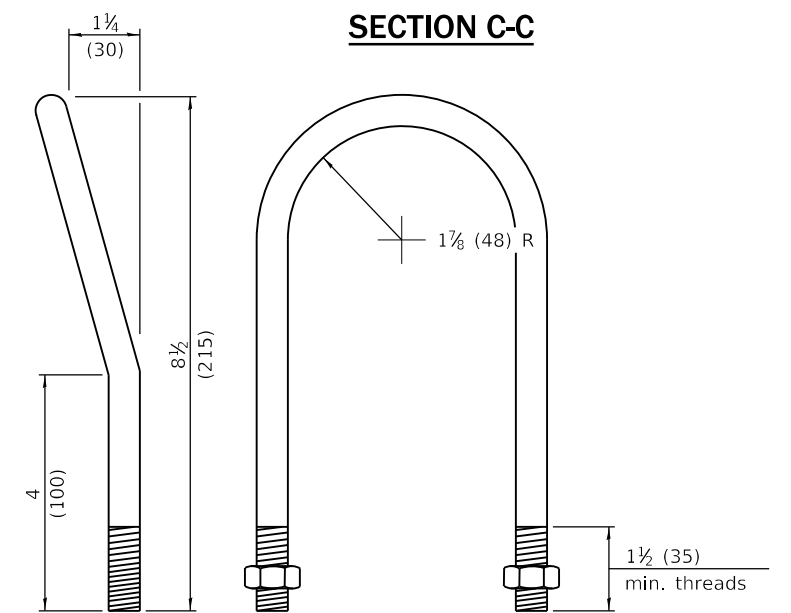

1/2 (M12) U BOLT
(4 - required)

INLET BOX
TYPE 36 (900) A

(Sheet 2 of 2)

STANDARD 542536-03

Illinois Department of Transportation

PASSED January 1, 2010

ENGINEER OF POLICY AND PROCEDURES

APPROVED January 1, 2010

ENGINEER OF DESIGN AND ENVIRONMENT

ISSUED 1-1-97

Material required for one inlet box

Bar	Qty.	Size	Length
h	11	No. 4 (No. 13)	14'-5" (4.40 m)
h2	8	No. 4 (No. 13)	4'-8" (1.40 m)
h3	2	No. 4 (No. 13)	5'-6" (1.70 m)
L	6	No. 4 (No. 13)	22 (550)
u	16	No. 4 (No. 13)	8'-9" (2.67 m)
u1	2	No. 4 (No. 13)	9'-9" (2.97 m)
v	8	No. 4 (No. 13)	4'-3" (1.30 m)
v1	6	No. 4 (No. 13)	3'-6" (1.07 m)
v2	13	No. 4 (No. 13)	33 (840)
v3	10	No. 4 (No. 13)	21 (530)
Concrete		cu. yds. (m ³)	5.0 (3.80)
Reinf. Bars		lbs. (kg)	324 (147)
Galv. Steel Pipe		3½ (89) O.D.	2 at 14'-3¼" (4.35 m)

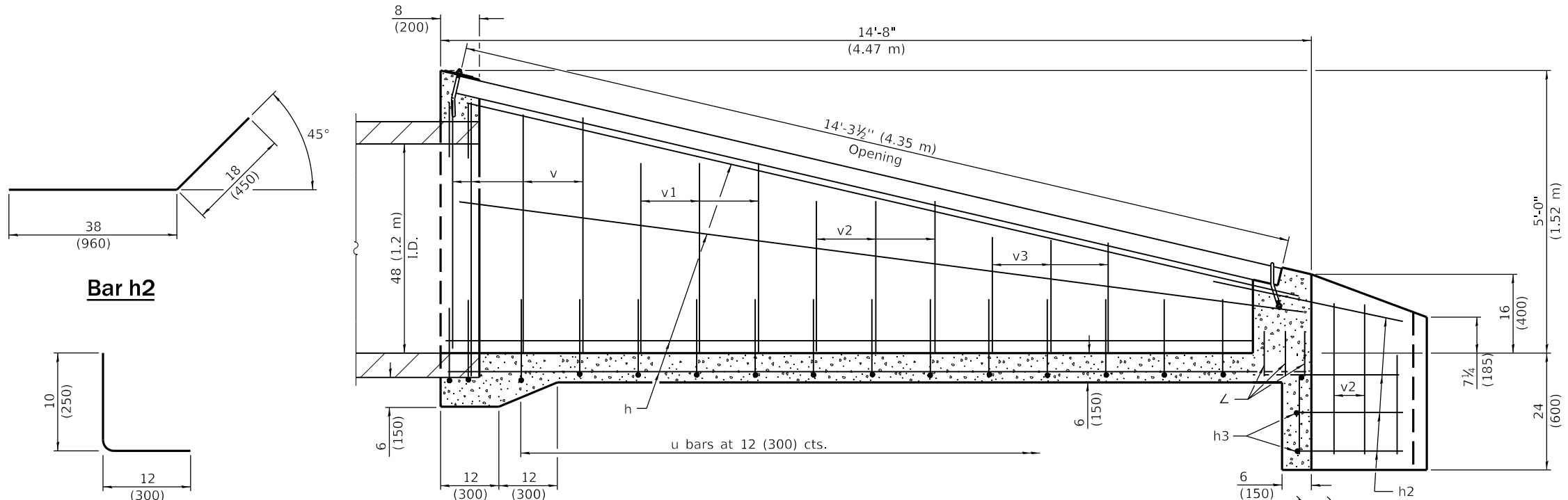

SECTION A-A

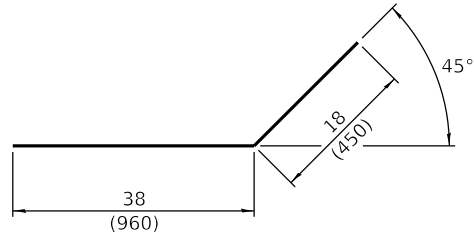

Bar h2

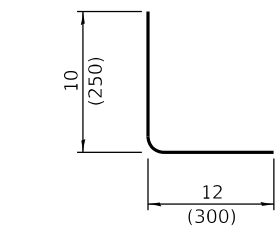

Bar L

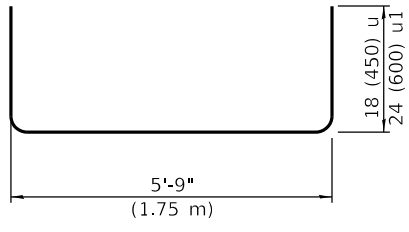

Bar u & u1

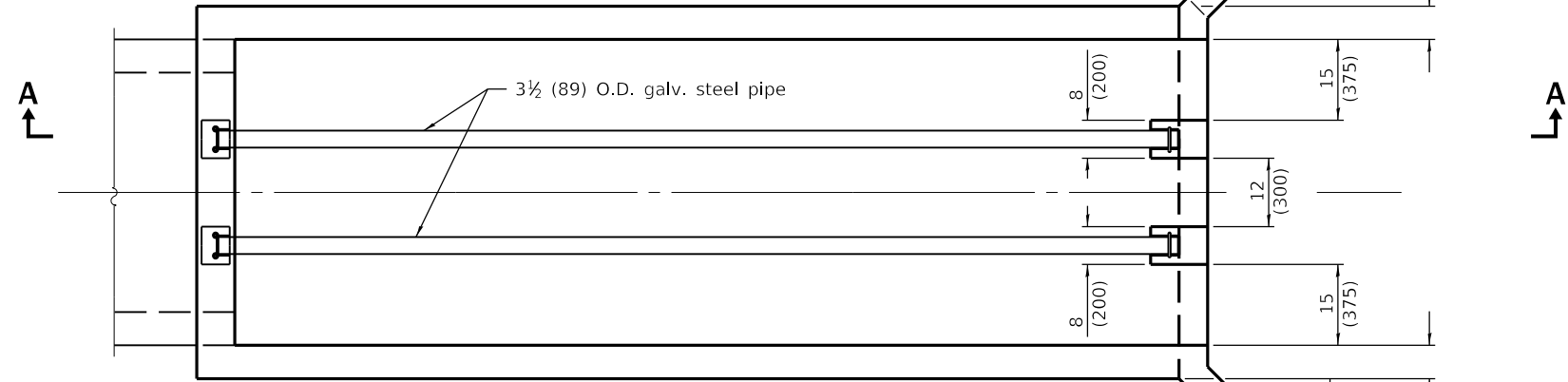

PLAN

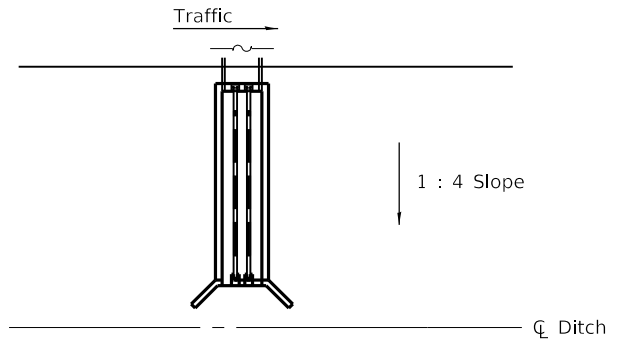

Sketch showing location and direction of box in relation to \bar{C} of ditch.

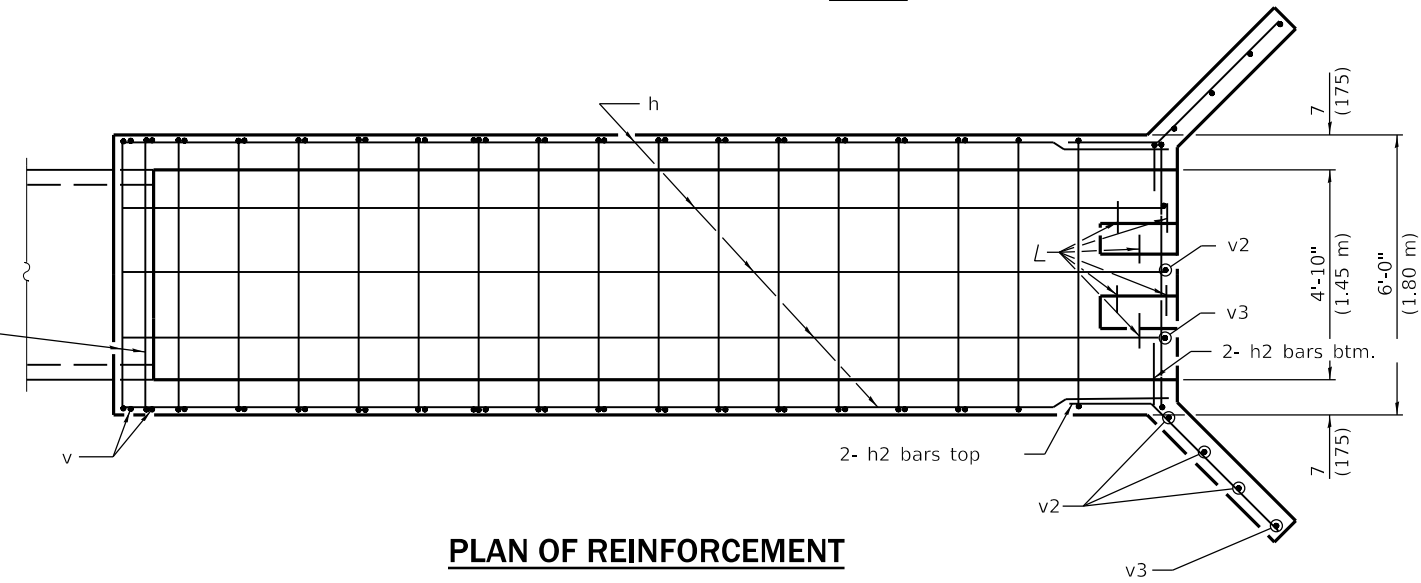

PLAN OF REINFORCEMENT

GENERAL NOTES

All slope ratios are expressed as units of vertical displacement to units of horizontal displacement (V:H).

All dimensions are in inches (millimeters) unless otherwise shown.

DATE	REVISIONS
1-1-09	Switched units to English (metric).
1-1-07	Soft converted metric rebars.

**INLET BOX
TYPE 48 (1200) A**

(Sheet 1 of 2)

STANDARD 542541-02

Illinois Department of Transportation

PASSED January 1, 2009

ENGINEER OF POLICY AND PROCEDURES

APPROVED January 1, 2009

ENGINEER OF DESIGN AND ENVIRONMENT

ISSUED 1-1-97

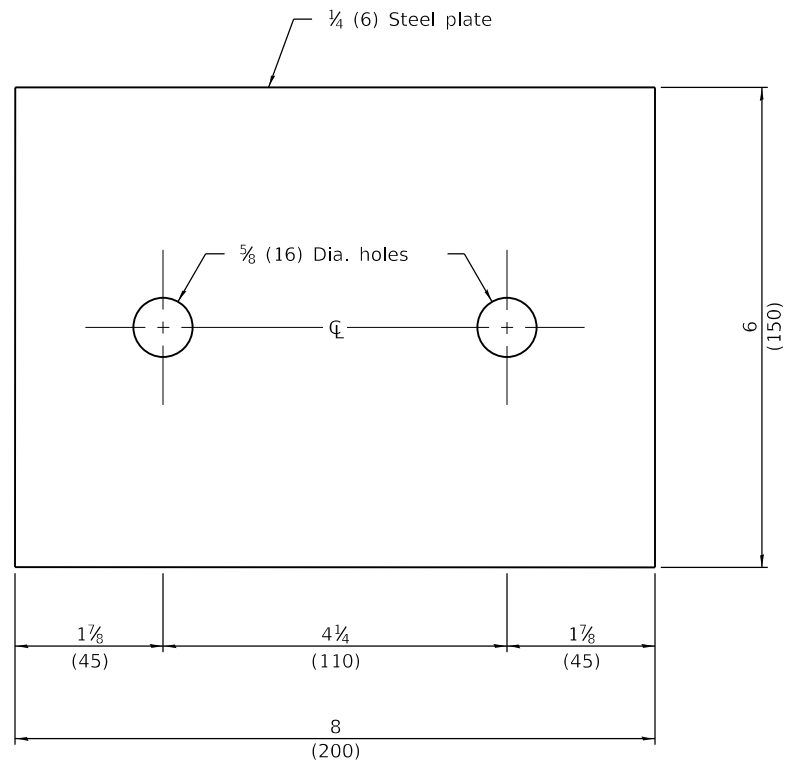

TOP ANCHOR PLATE
(2 - required)

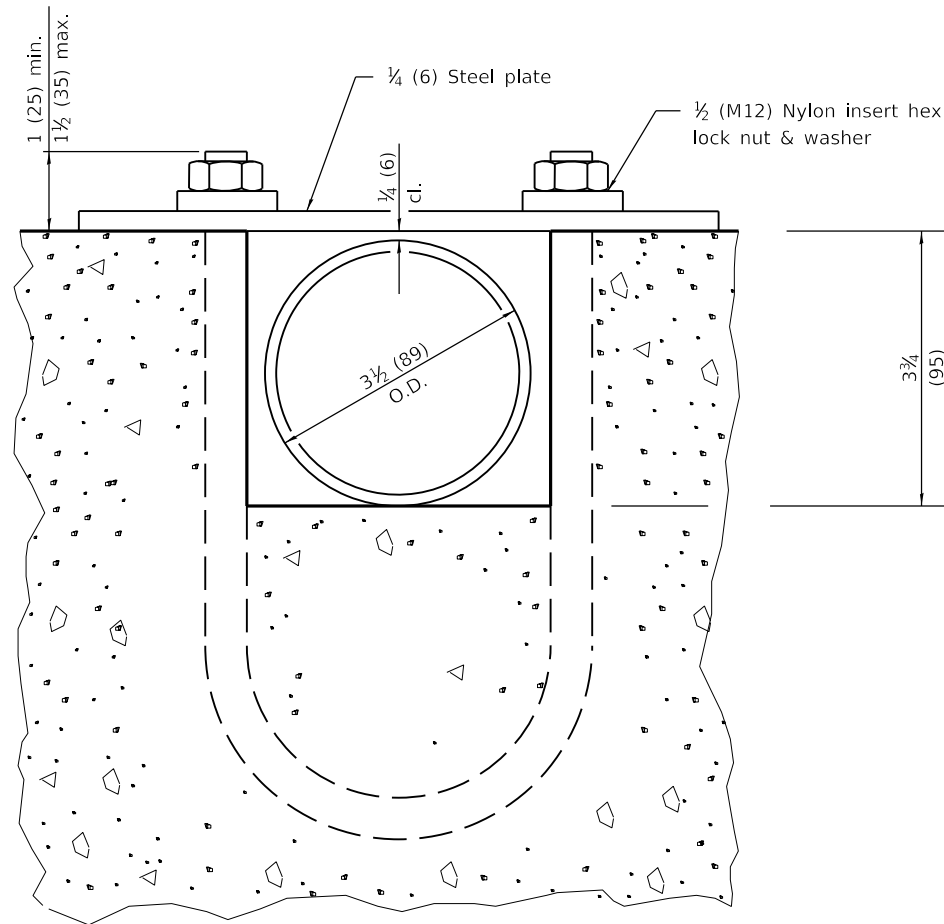

SECTION B-B

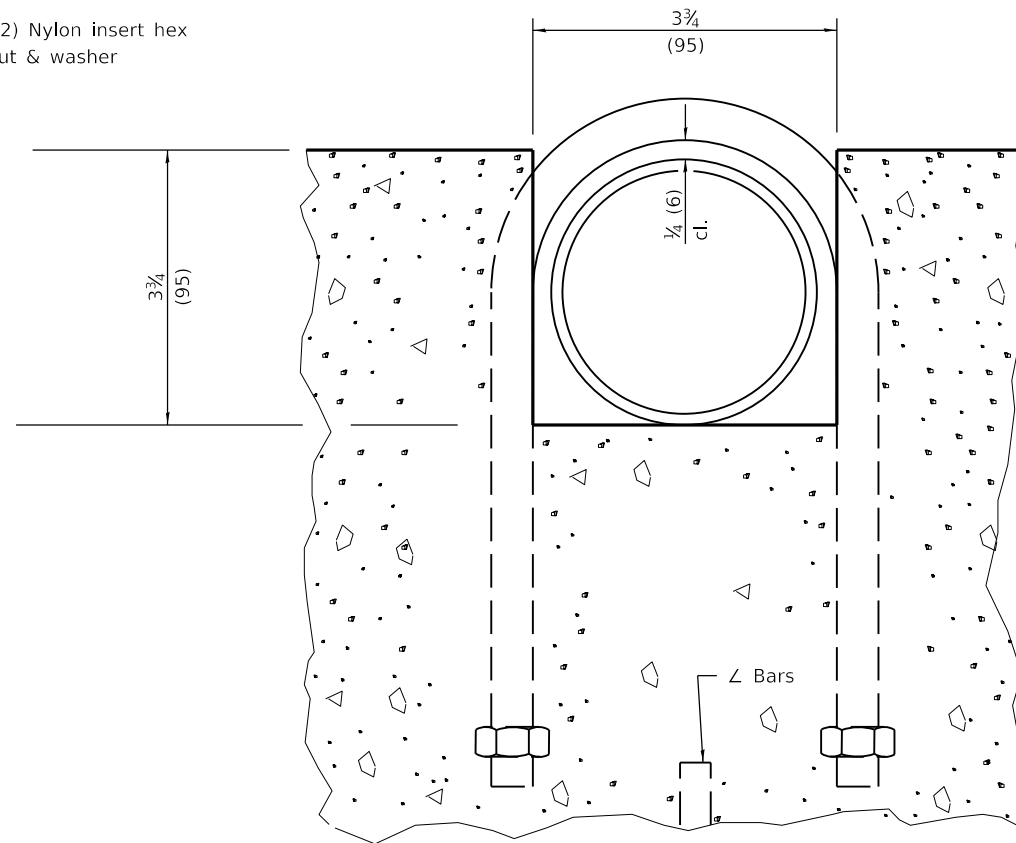

SECTION C-C

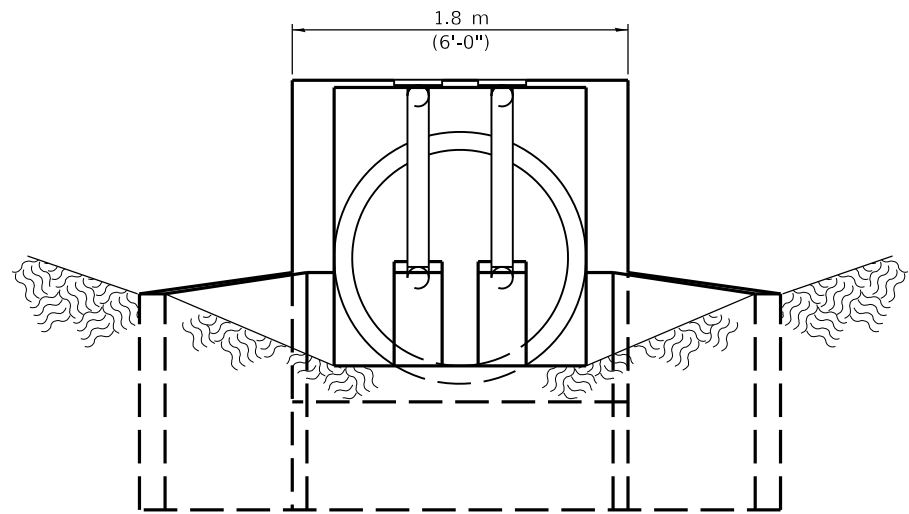

END VIEW

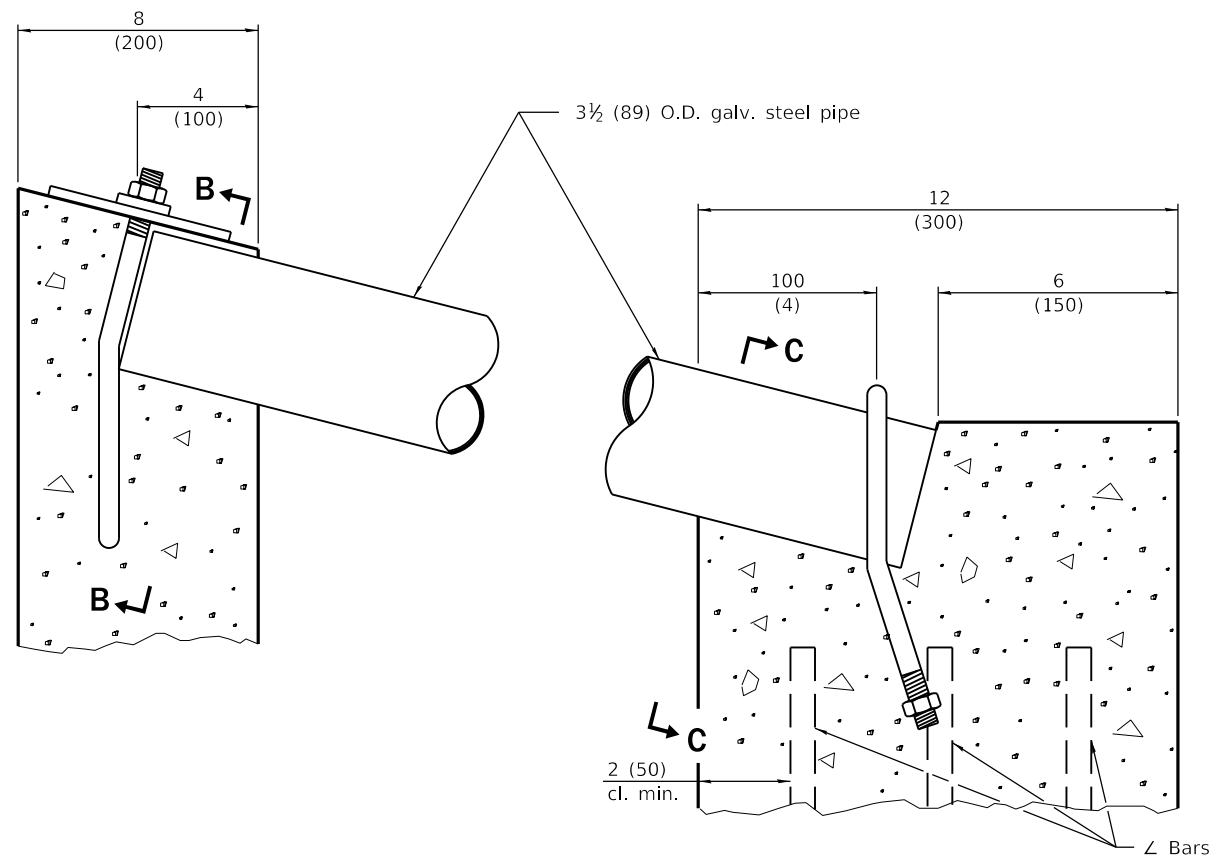

DETAIL AT BLOCKOUTS

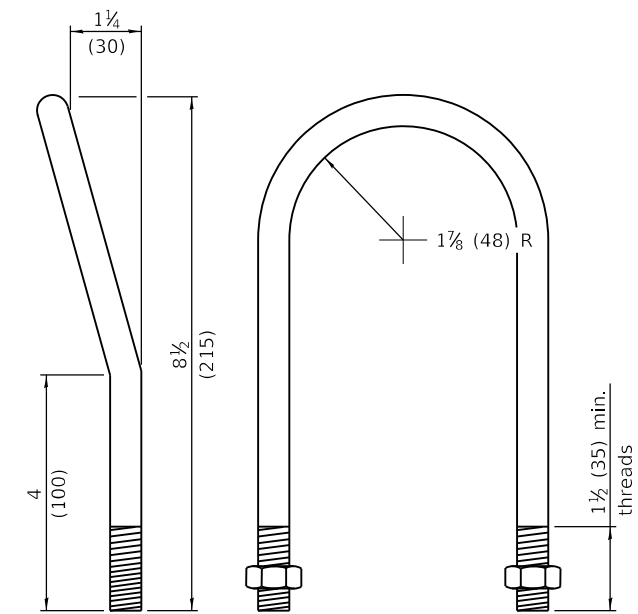

1/2 (M12) U BOLT
(4 - required)

**INLET BOX
TYPE 48 (1200) A**

(Sheet 2 of 2)

STANDARD 542541-02

Illinois Department of Transportation

PASSED January 1, 2009

ENGINEER OF POLICY AND PROCEDURES

APPROVED January 1, 2009

ENGINEER OF DESIGN AND ENVIRONMENT

ISSUED 1-1-97

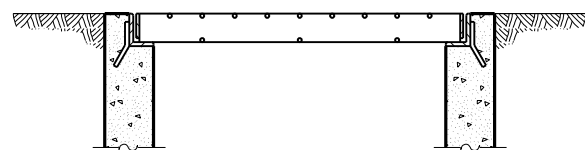
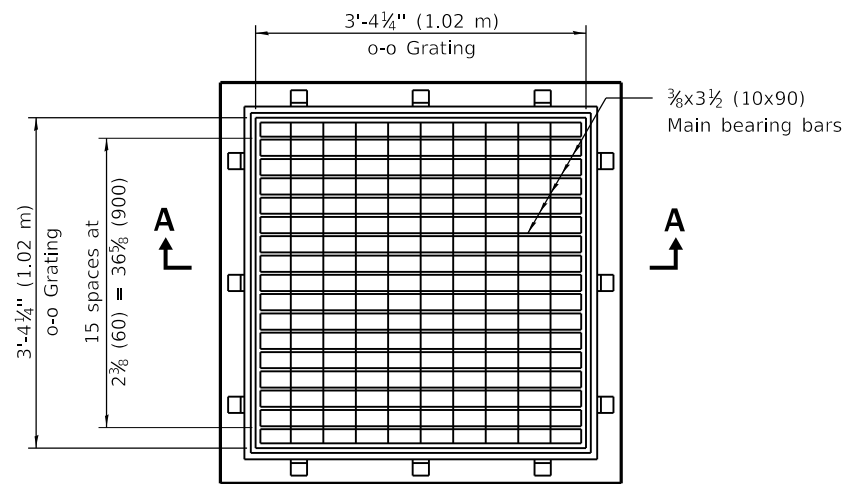

SECTION A-A

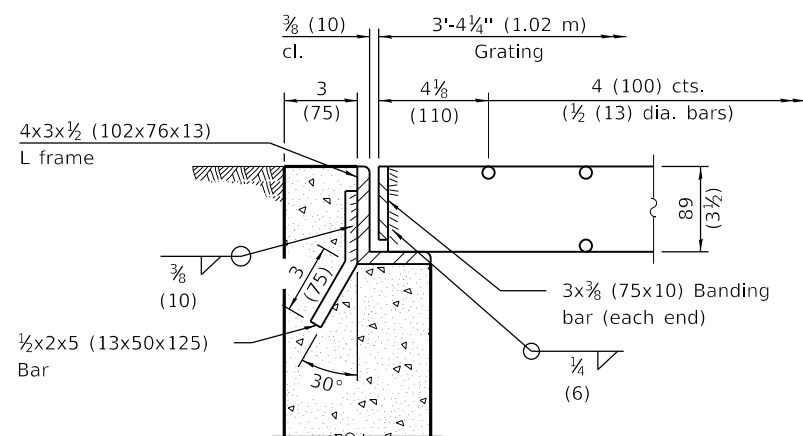

STEEL FRAME & GRATE

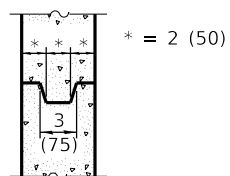

DETAIL of OPTIONAL JOINT

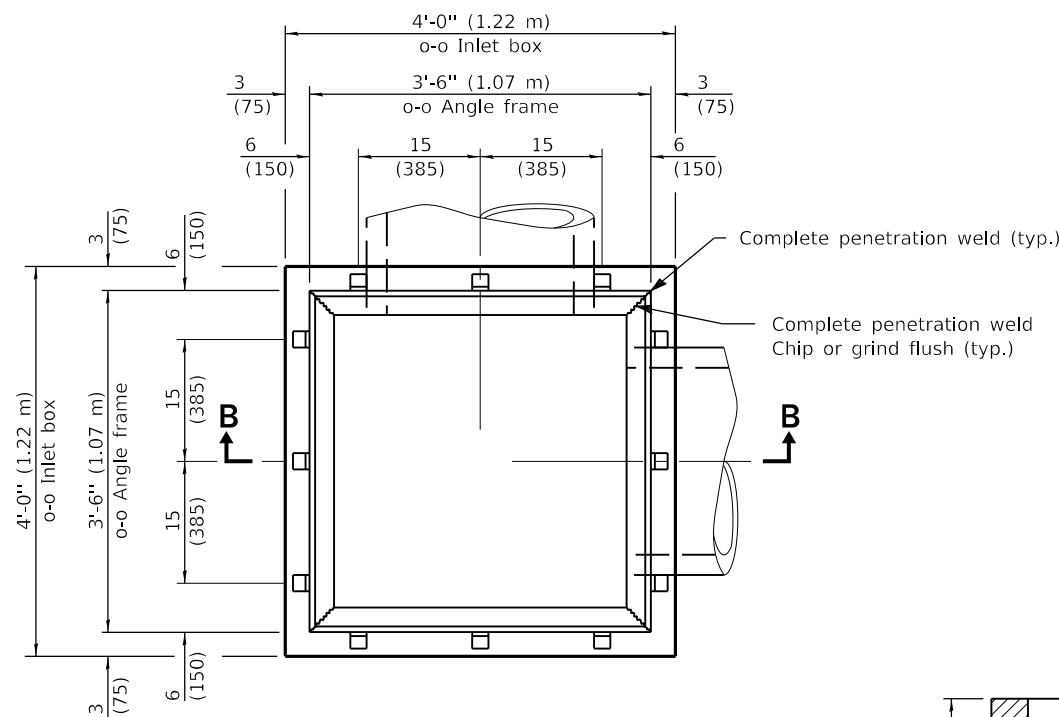

PLAN
(Grating omitted for clarity)

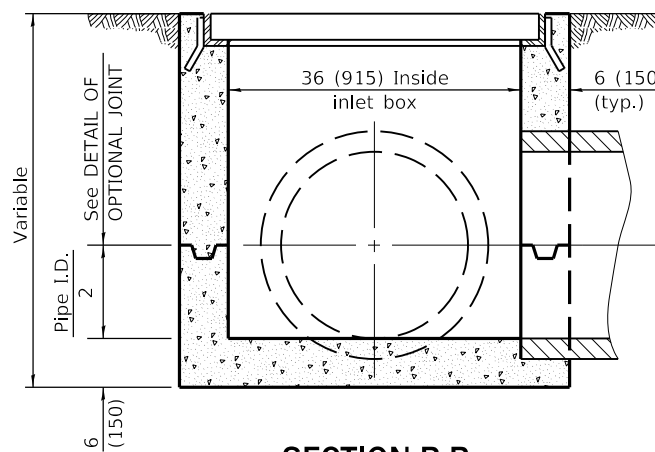

SECTION B-B

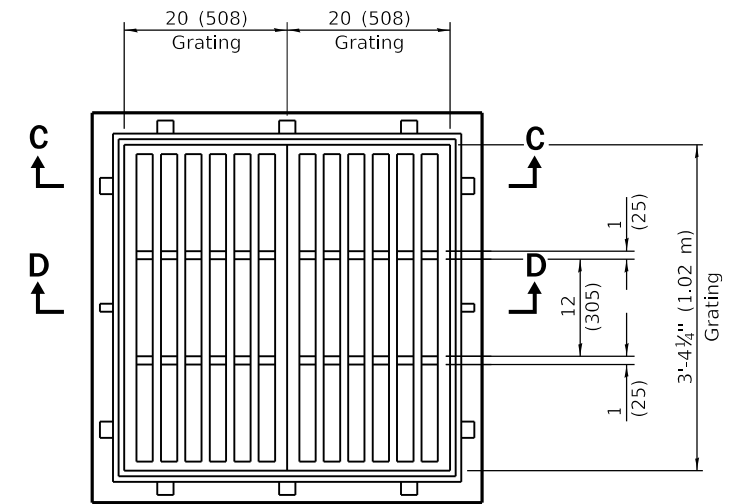

SECTION C-C

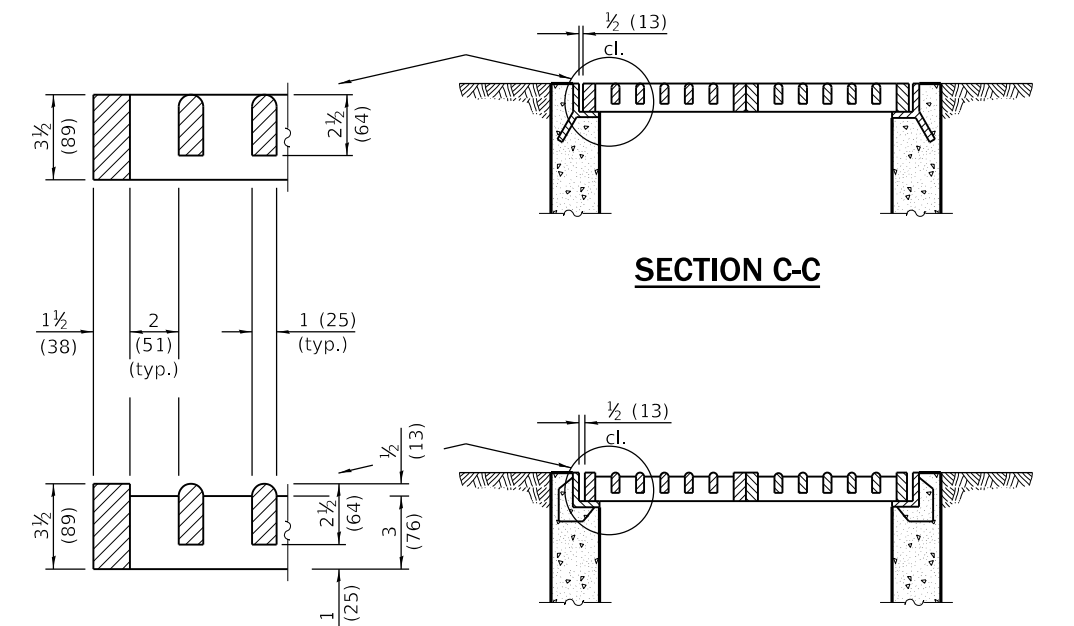

**SECTION D-D
CAST FRAME & GRATE**

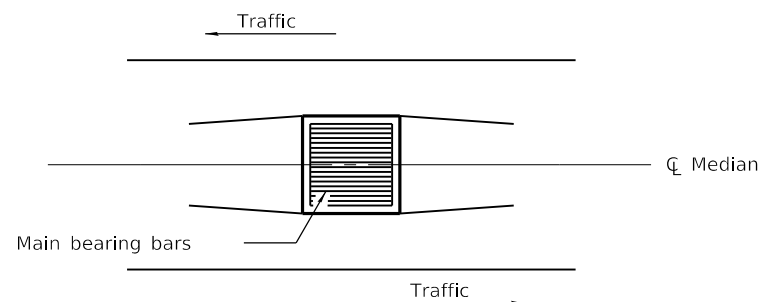

Sketch showing location and direction of main bearing bars in relation to \bar{C} Median

All dimensions are in inches (millimeters) unless otherwise shown.

DATE	REVISIONS
1-1-09	Switched units to English (metric).
1-1-97	Renum. Standard 2240-6.

**FLUSH INLET BOX
FOR MEDIAN**

STANDARD 542546-01

Illinois Department of Transportation

PASSED January 1, 2009

ENGINEER OF POLICY AND PROCEDURES

APPROVED January 1, 2009

ENGINEER OF DESIGN AND ENVIRONMENT

ISSUED 1-1-97

Remove concrete along these lines. Clean reinforcement for either tied or welded laps of longitudinal and circumferential reinforcement.

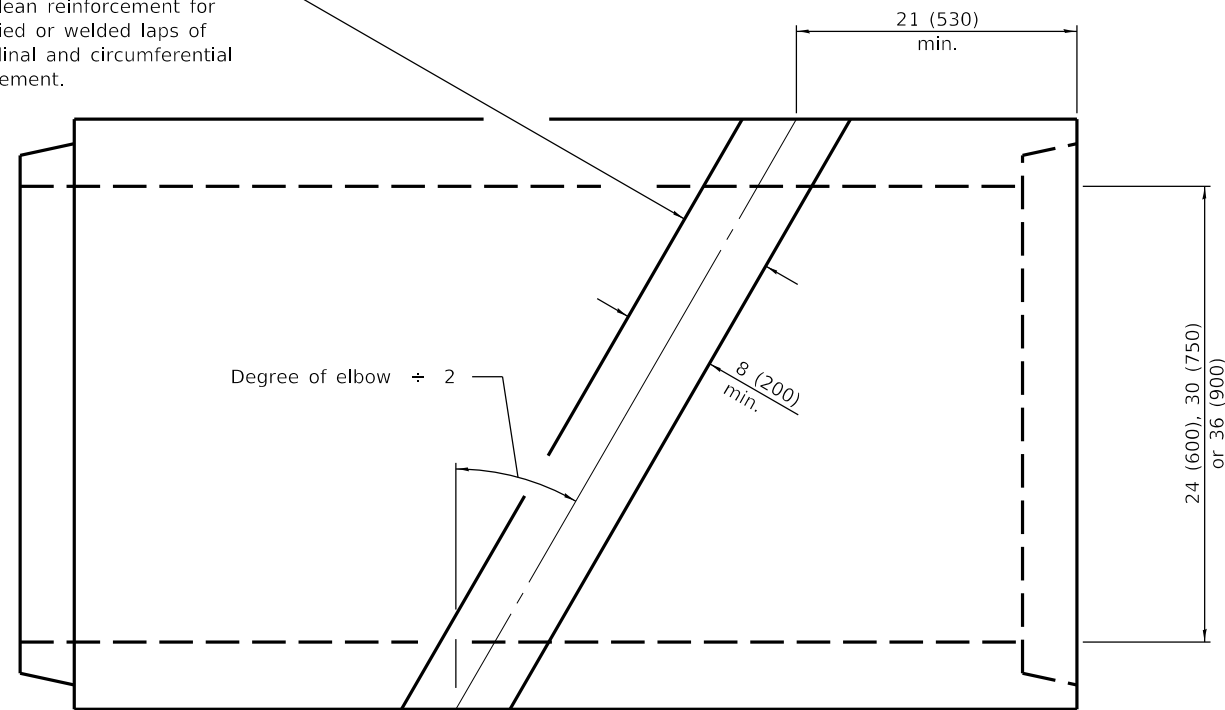

PLAN
(Reinforced concrete pipe)

1½ (40) min., 2½ (65) max. (Tied lap)
1½ (40) min., 6 (150) max. (Welded lap)

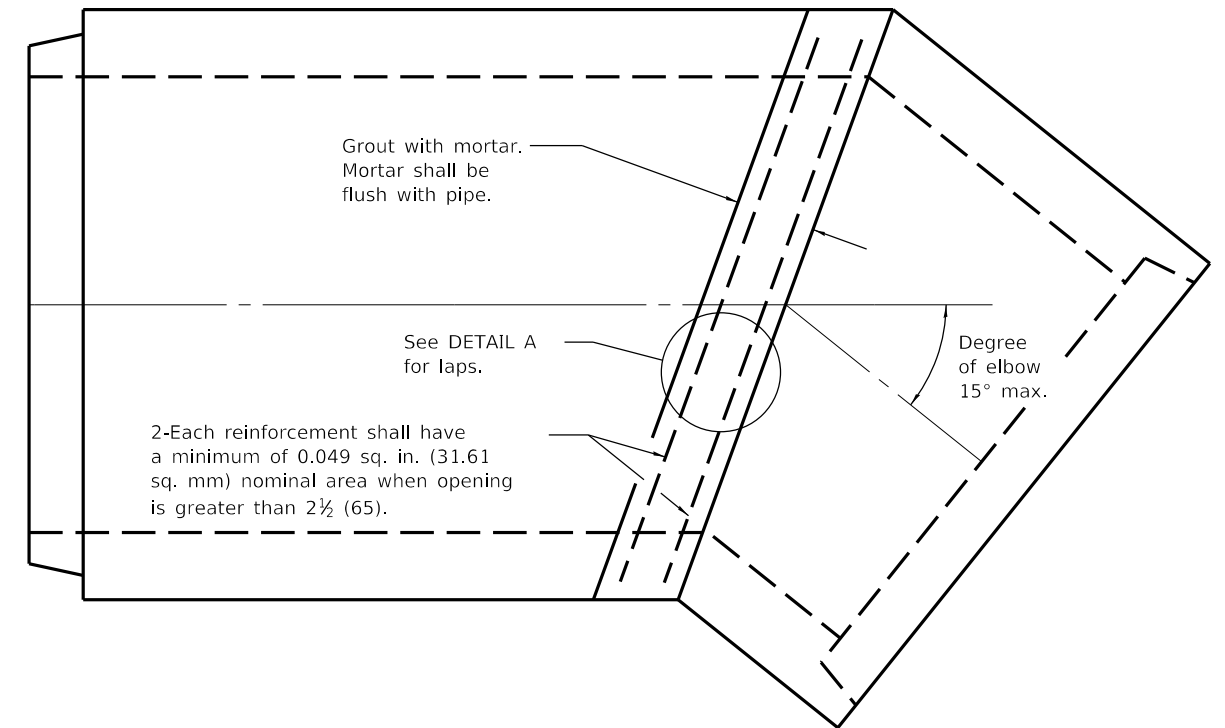

PLAN
(Reinforced concrete pipe elbow)

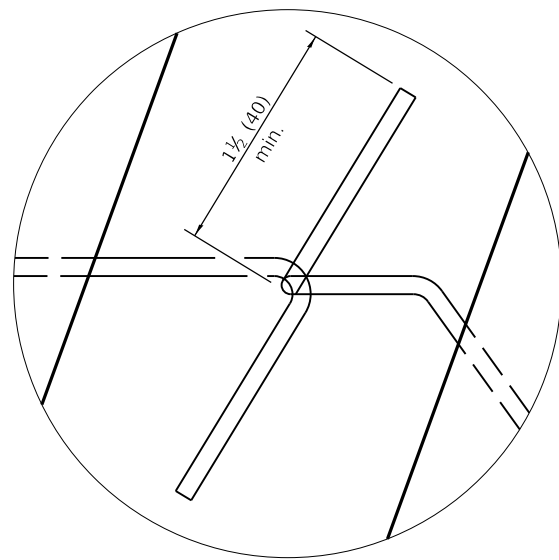

TIED LAP

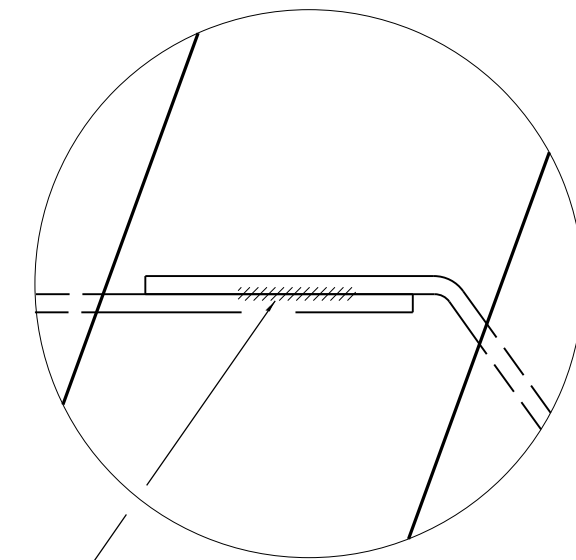

For wire dia. W14 - W6 (10.72 - 7.01),
length of weld shall be ¼ (20) min.
For wire dia. W5.5 - W2.9 (6.73 - 4.88),
length of weld shall be ⅜ (10) min.
Other wire dia. shall be tied per detail.

DETAIL A

WELDED LAP

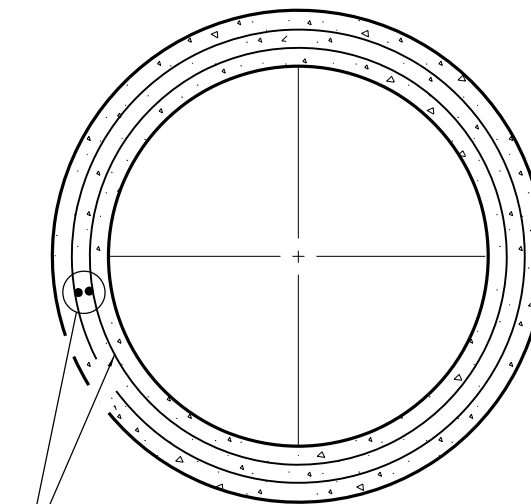

TRANSVERSE SECTION

All dimensions are in inches (millimeters)
unless otherwise shown.

DATE	REVISIONS
1-1-11	Corr. weld sym. on WELDED LAP det. Added pipe dia. to title. Set elbow to 15° max.
1-1-10	Corrected pipe diameter dimension lines.

**REINFORCED CONCRETE PIPE
ELBOW 24", 30" OR 36"
(600 mm, 750 mm OR 900 mm)**

STANDARD 542601-03

Illinois Department of Transportation

PASSED January 1, 2011
Michael Brand
ENGINEER OF POLICY AND PROCEDURES

APPROVED January 1, 2011
Scott S. Smith
ENGINEER OF DESIGN AND ENVIRONMENT

ISSUED 1-1-97

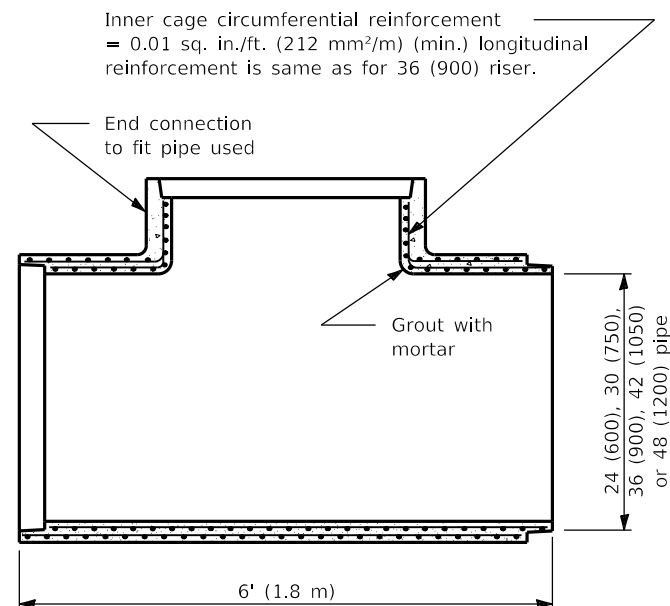

LONGITUDINAL SECTION

For wire W12 thru W2 (10.008 thru 7.188), length of weld shall be $\frac{3}{4}$ (20) min.
 For wire W5.5 thru W2.5 (6.655 thru 4.496), length of weld shall be $\frac{5}{8}$ (10) min.
 Other wire gauges shall be tied per detail.

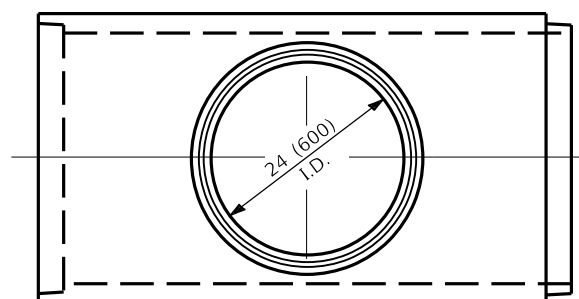

**PLAN
TEE WITH 24 (600) RISER**

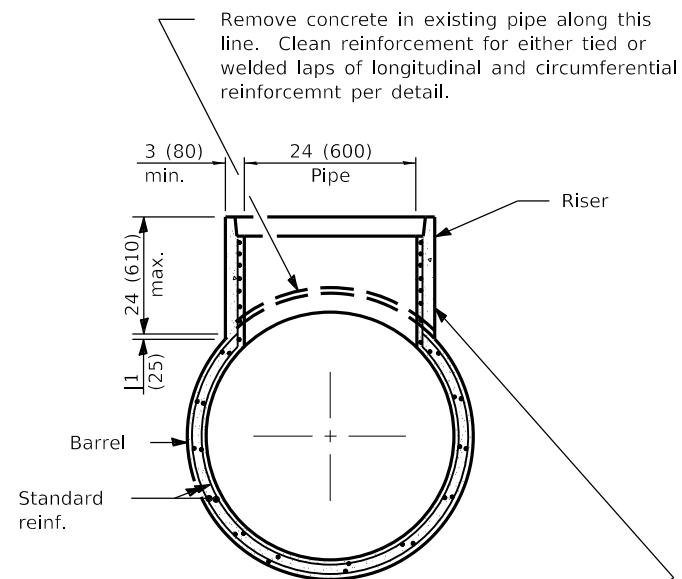

TRANSVERSE SECTION

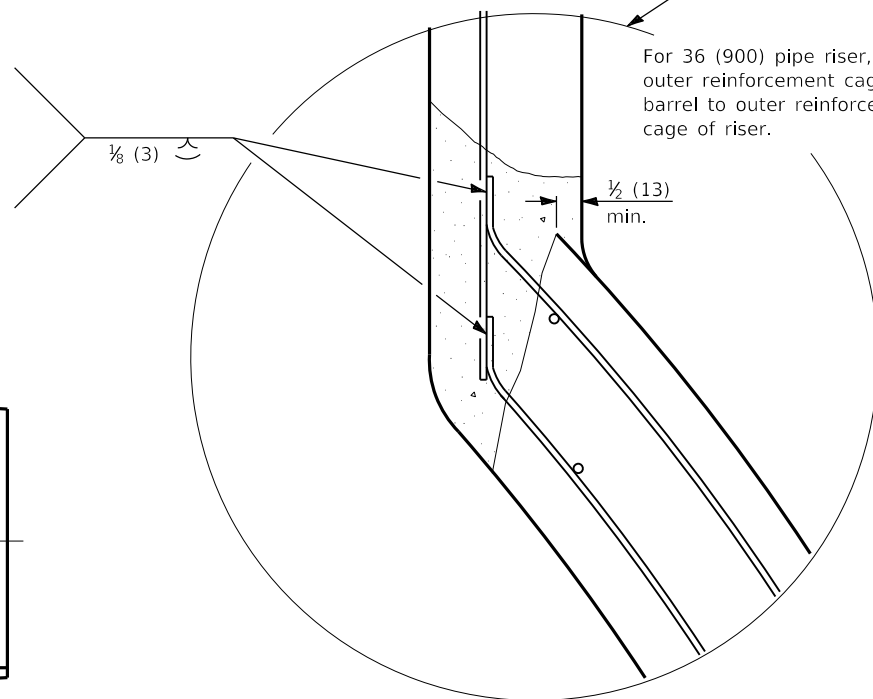

WELDED LAP

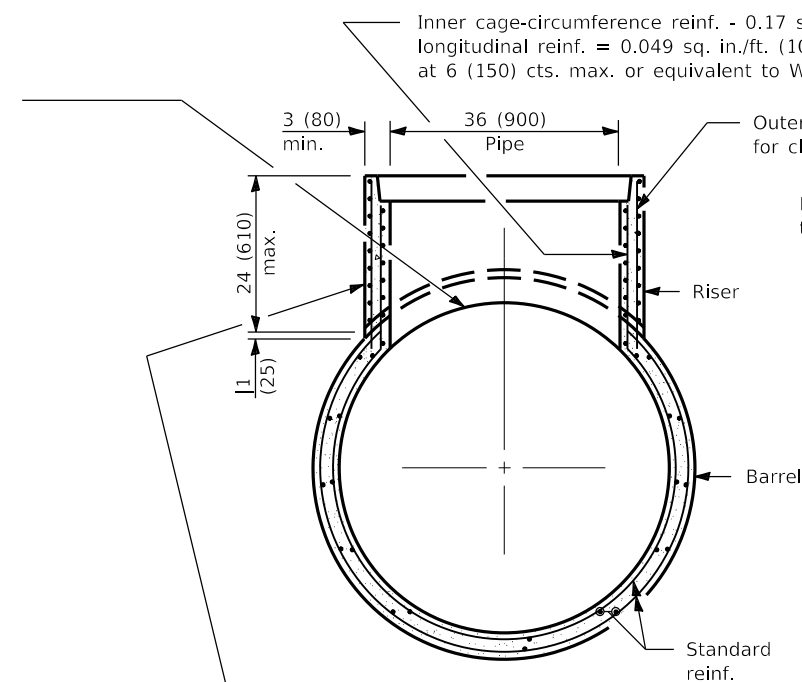

TRANSVERSE SECTION

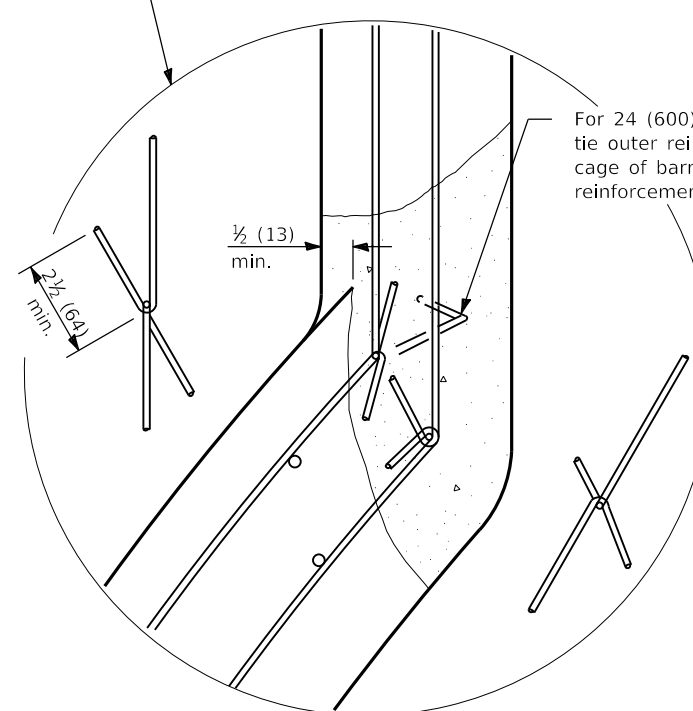

TIED LAP

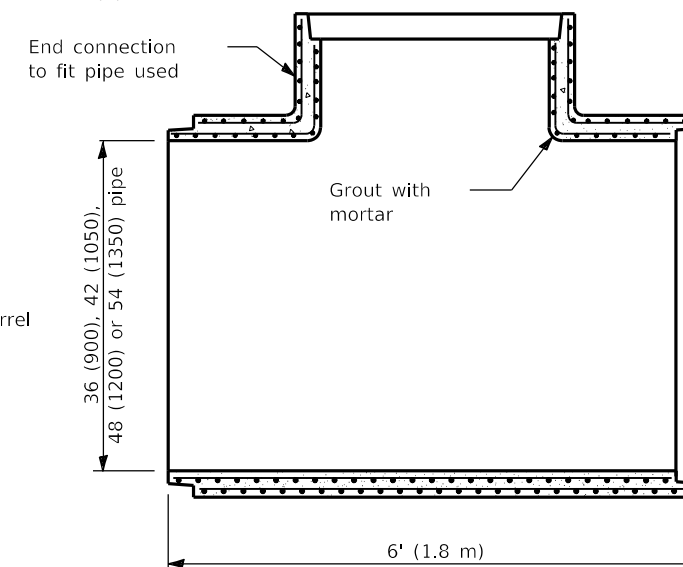

LONGITUDINAL SECTION

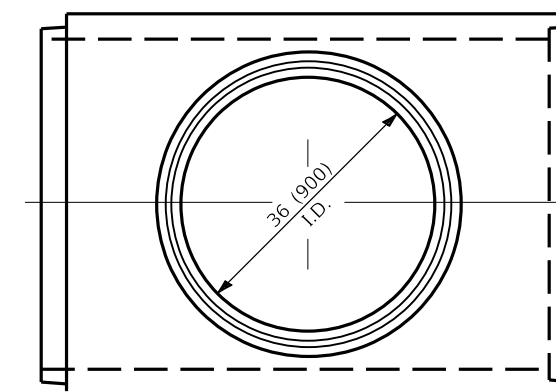

**PLAN
TEE WITH 36 (900) RISER**

All dimensions are in inches (millimeters) unless otherwise shown.

DATE	REVISIONS
1-1-11	Corrected weld symbol on Welded Lap detail.
1-1-09	Switched units to English (metric).

**REINFORCED CONCRETE
PIPE TEE**

STANDARD 542606-02

Illinois Department of Transportation

PASSED January 1, 2011
Michael Beard
 ENGINEER OF POLICY AND PROCEDURES

APPROVED January 1, 2011
Scott Schick
 ENGINEER OF DESIGN AND ENVIRONMENT

ISSUED 1-1-97

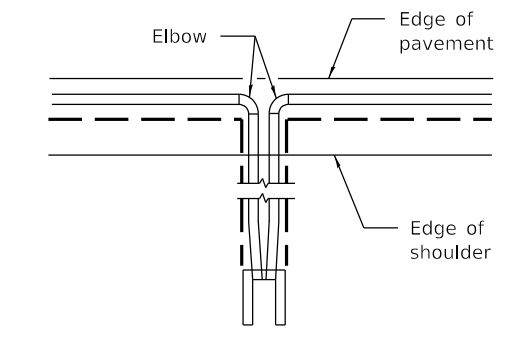
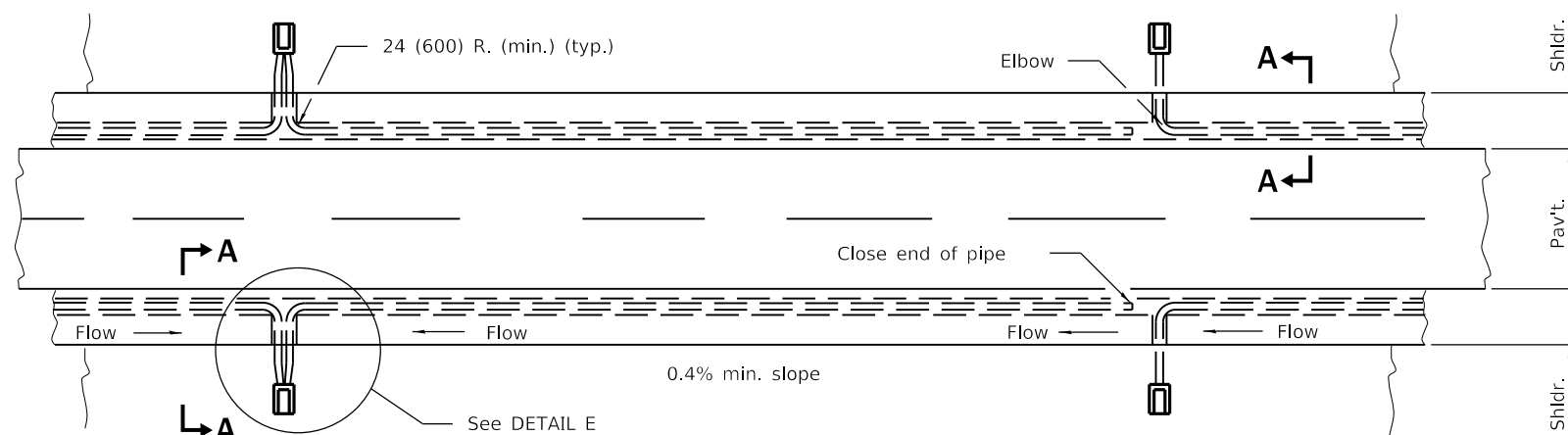

Width min. = O.D. + 4 (100)
Width max. = 12 (300)

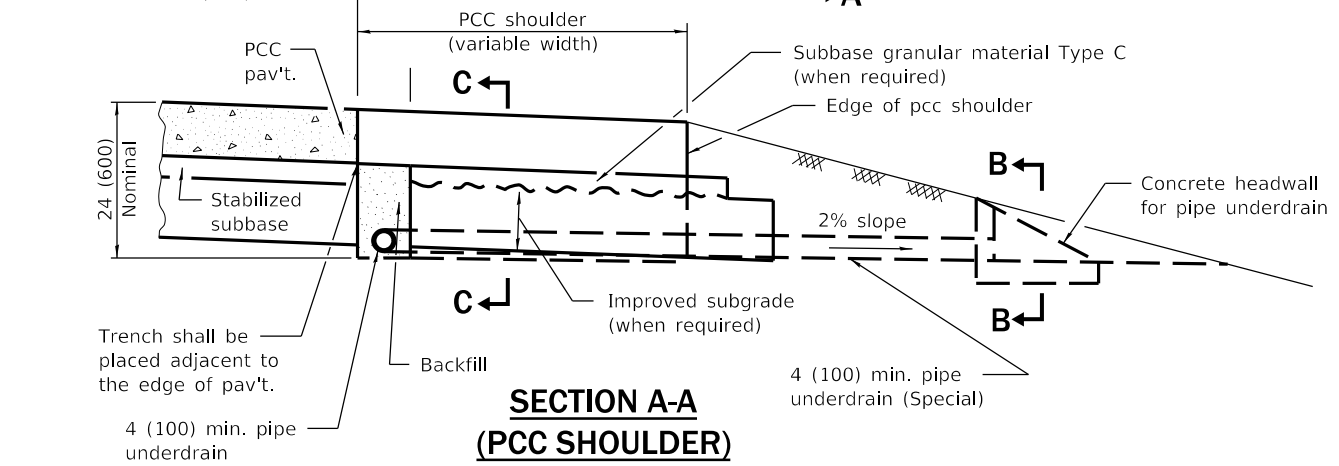

PLAN

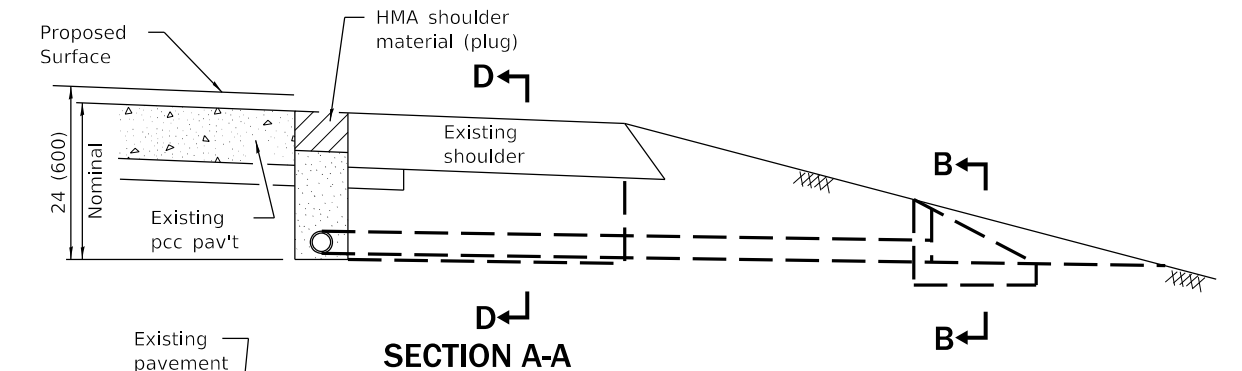

SECTION A-A

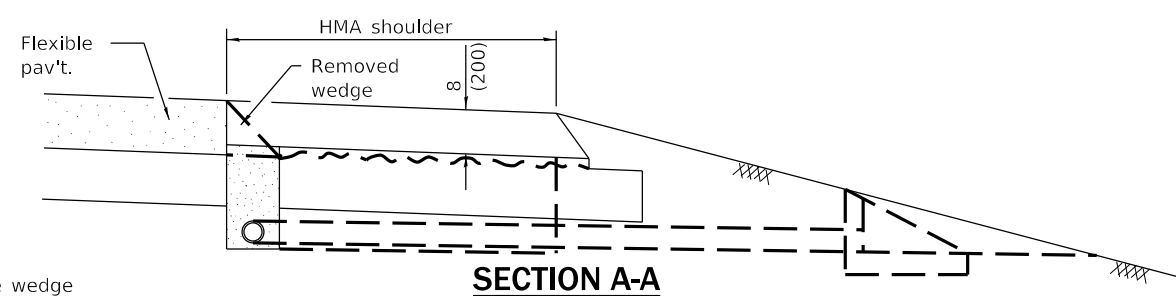

SECTION A-A (HMA SHOULDER)

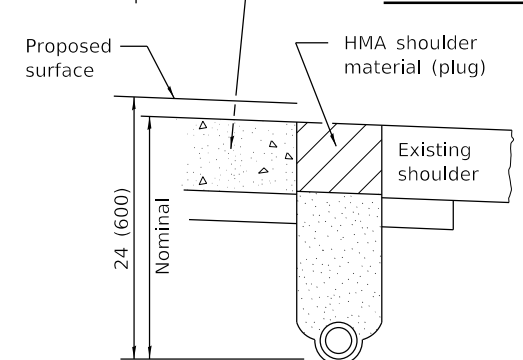

SECTION A-A

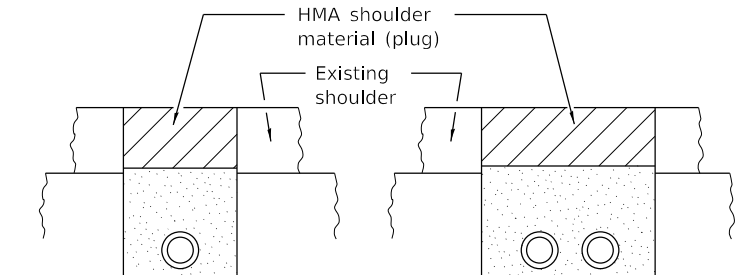

SECTION D-D

SECTION D-D (Sag Locations)

TRENCH FOR CORRUGATED POLYETHYLENE TUBING ALTERNATE

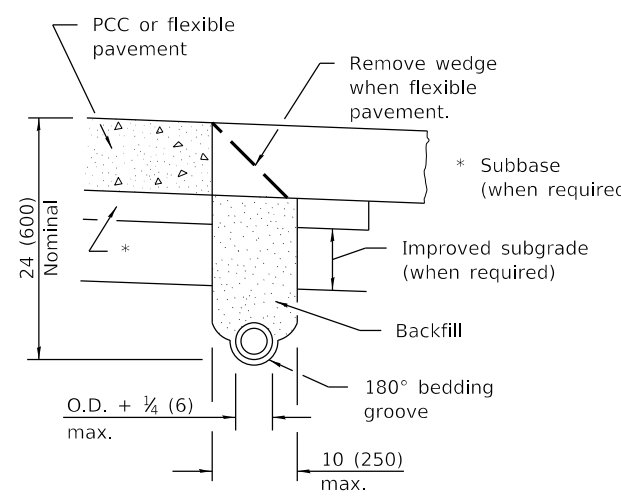

TRENCH FOR CORRUGATED POLYETHYLENE TUBING ALTERNATE

(Dimensions and notes not shown shall be as shown in the above Section A-A)

Width min. = (2xO.D.) + 6 (150)
Width max. = 18 (450)

Width min. = O.D. + 4 (100)
Width max. = 12 (300)

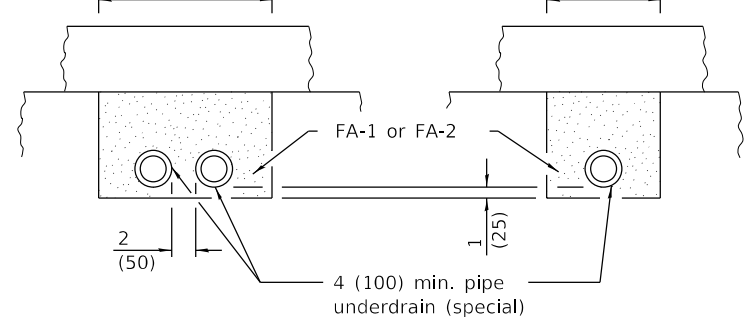

SECTION C-C (Sag Locations)

SECTION C-C (Sag Locations)

NEW CONSTRUCTION

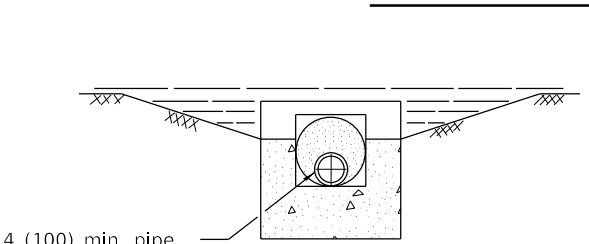

SECTION B-B

4 (100) min. pipe underdrain (special)

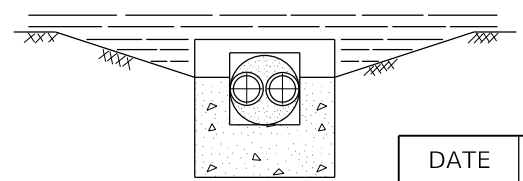

SECTION B-B (Sag Locations)

EXISTING CONSTRUCTION

(Except as noted or shown, dimensions and notes specified for Existing Construction are the same as those of New Construction)

GENERAL NOTES

See Standard 601101 for details of concrete headwall.

See Standards 482001, 482006 and 483001 for details of shoulders not shown.

The 24 (600) radius on the drainage fitting is only a minimum. Larger radii meeting the approval of the Engineer may be substituted.

All dimensions are in inches (millimeters) unless otherwise shown.

DATE	REVISIONS
4-1-16	Renamed standard. Omitted drainage mat option.
1-1-11	Added 'PCC' and 'HMA' to SECTION A-A titles on Sheet 2.

PIPE UNDERDRAINS

STANDARD 601001-05

Illinois Department of Transportation

PASSED April 1, 2016
Michael Beard
ENGINEER OF POLICY AND PROCEDURES

APPROVED April 1, 2016
[Signature]
ENGINEER OF DESIGN AND ENVIRONMENT

ISSUED 1-1-97

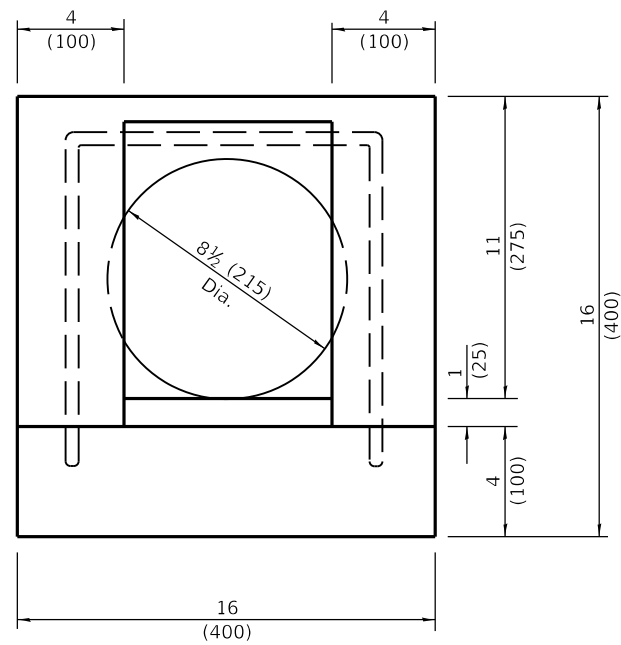

FRONT VIEW

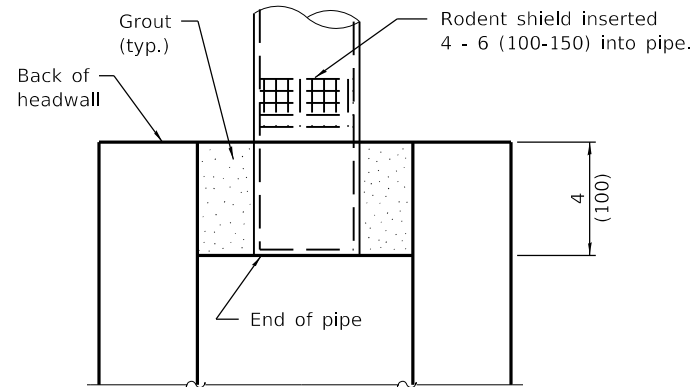

RODENT SHIELD PLACEMENT

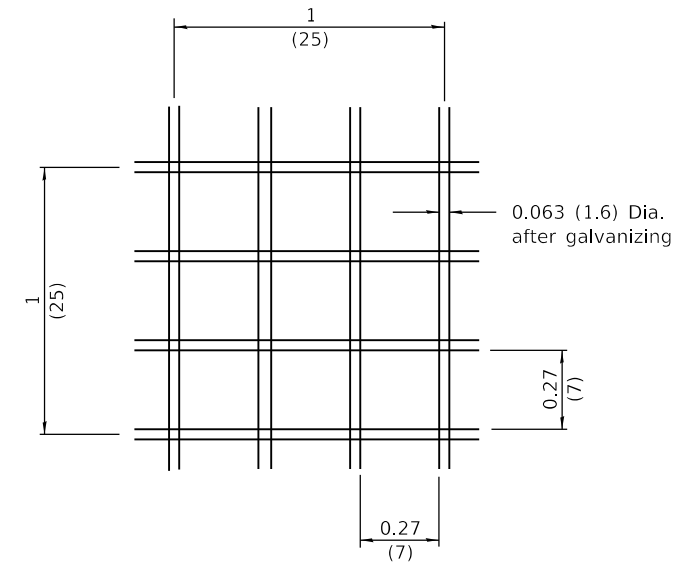

SECTION A-A

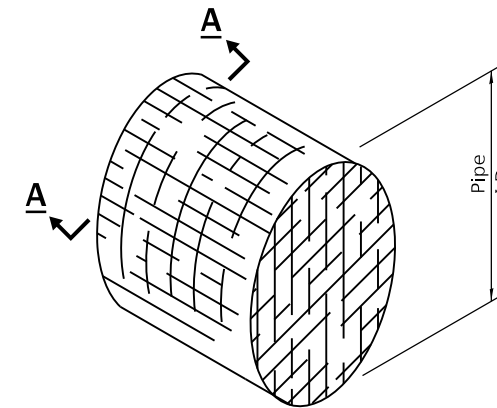

DETAIL OF RODENT SHIELD

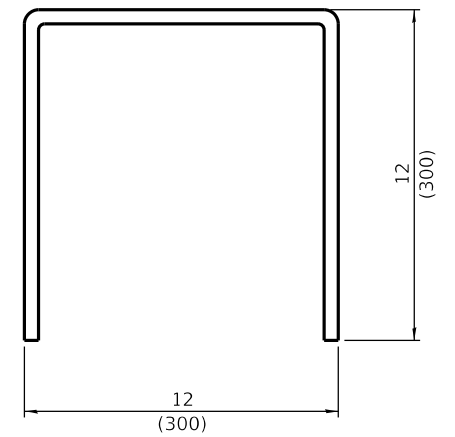

BAR h

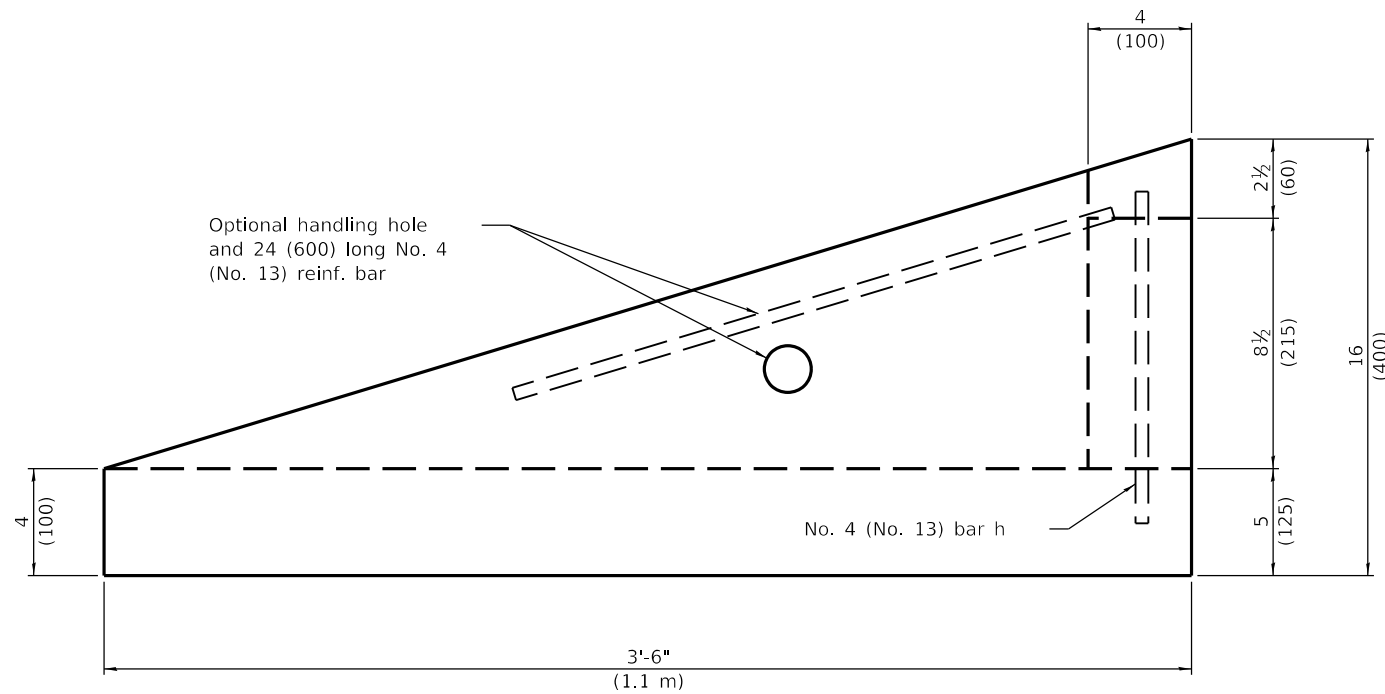

SIDE VIEW

GENERAL NOTES

An alternate paved invert meeting the approval of the Engineer may be substituted for that shown in side view.

All dimensions are in inches (millimeters) unless otherwise shown.

DATE	REVISIONS
4-1-16	Renamed standard to be consistent with specs and other standards.
1-1-09	Switched units to English (metric).

CONCRETE HEADWALL FOR PIPE UNDERDRAINS

STANDARD 601101-02

Illinois Department of Transportation

PASSED April 1, 2016

Michael Beard
ENGINEER OF POLICY AND PROCEDURES

APPROVED April 1, 2016

[Signature]
ENGINEER OF DESIGN AND ENVIRONMENT

ISSUED 1-1-97

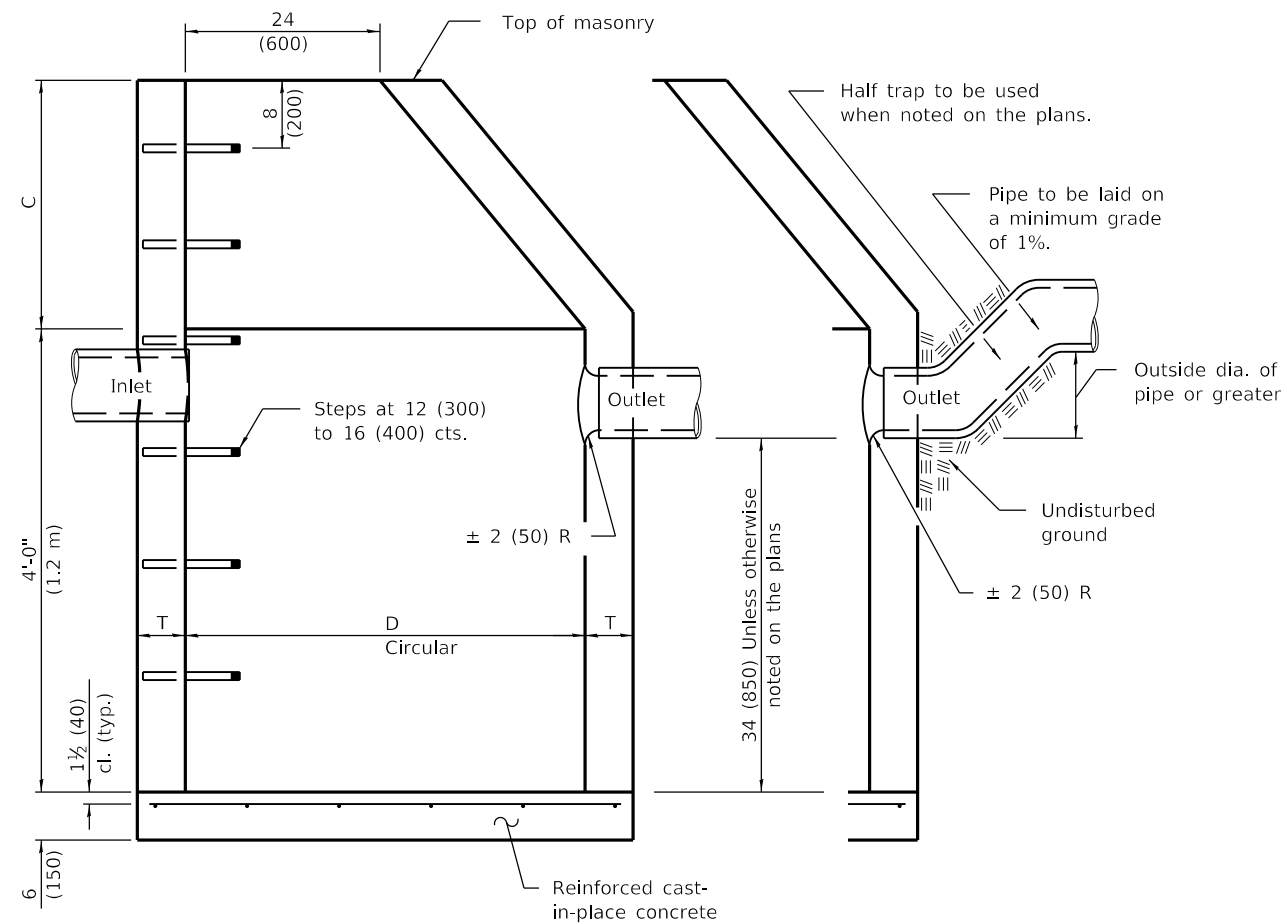

ELEVATION
(Standard Outlet)

ELEVATION
(Half Trap)

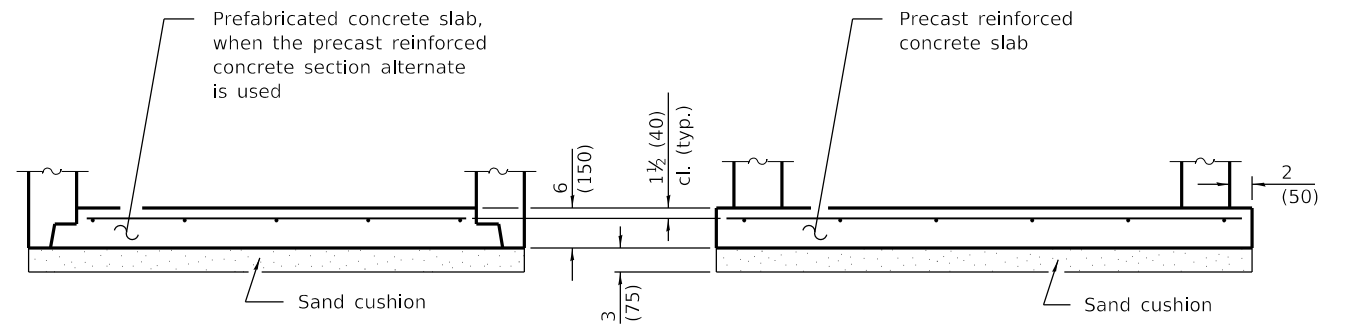

ALTERNATE BOTTOM SLAB

ALTERNATE MATERIALS FOR WALLS	D	C*	T (min.)
Concrete Masonry Unit	4'-0" (1.2 m)	30 (750)	5 (125)
	5'-0" (1.5 m)	3'-9" (1.15 m)	5 (125)
Brick Masonry	4'-0" (1.2 m)	30 (750)	8 (200)
	5'-0" (1.5 m)	3'-9" (1.15 m)	8 (200)
Precast Reinforced Concrete Section	4'-0" (1.2 m)	30 (750)	4 (100)
	5'-0" (1.5 m)	3'-9" (1.15 m)	5 (125)
Cast-in-place Concrete	4'-0" (1.2 m)	30 (750)	6 (150)
	5'-0" (1.5 m)	3'-9" (1.15 m)	6 (150)

* For precast reinforced concrete sections, dimension "C" may vary from the dimension given to plus 6 (150).

GENERAL NOTES

Bottom slabs shall be reinforced with a minimum of 0.20 sq. in./ft (420 sq. mm/m) in both directions with a maximum spacing of 12 (300).

Bottom slabs may be connected to the riser as determined by the fabricator; however, only a single row of reinforcement around the perimeter may be utilized.

See Standard 602601 for optional precast reinforced concrete flat slab top.

See Standard 602701 for details of steps.

All dimensions are in inches (millimeters) unless otherwise shown.

Illinois Department of Transportation

PASSED January 1, 2011
Michael Beard
 ENGINEER OF POLICY AND PROCEDURES

APPROVED January 1, 2011
Scott Schick
 ENGINEER OF DESIGN AND ENVIRONMENT

ISSUED 1-1-97

DATE	REVISIONS
1-1-11	Added 'Outside' to half trap note. Detail rein. in slabs.
	Revised general notes.
1-1-09	Switched units to English (metric).

**CATCH BASIN
TYPE A**

STANDARD 602001-02

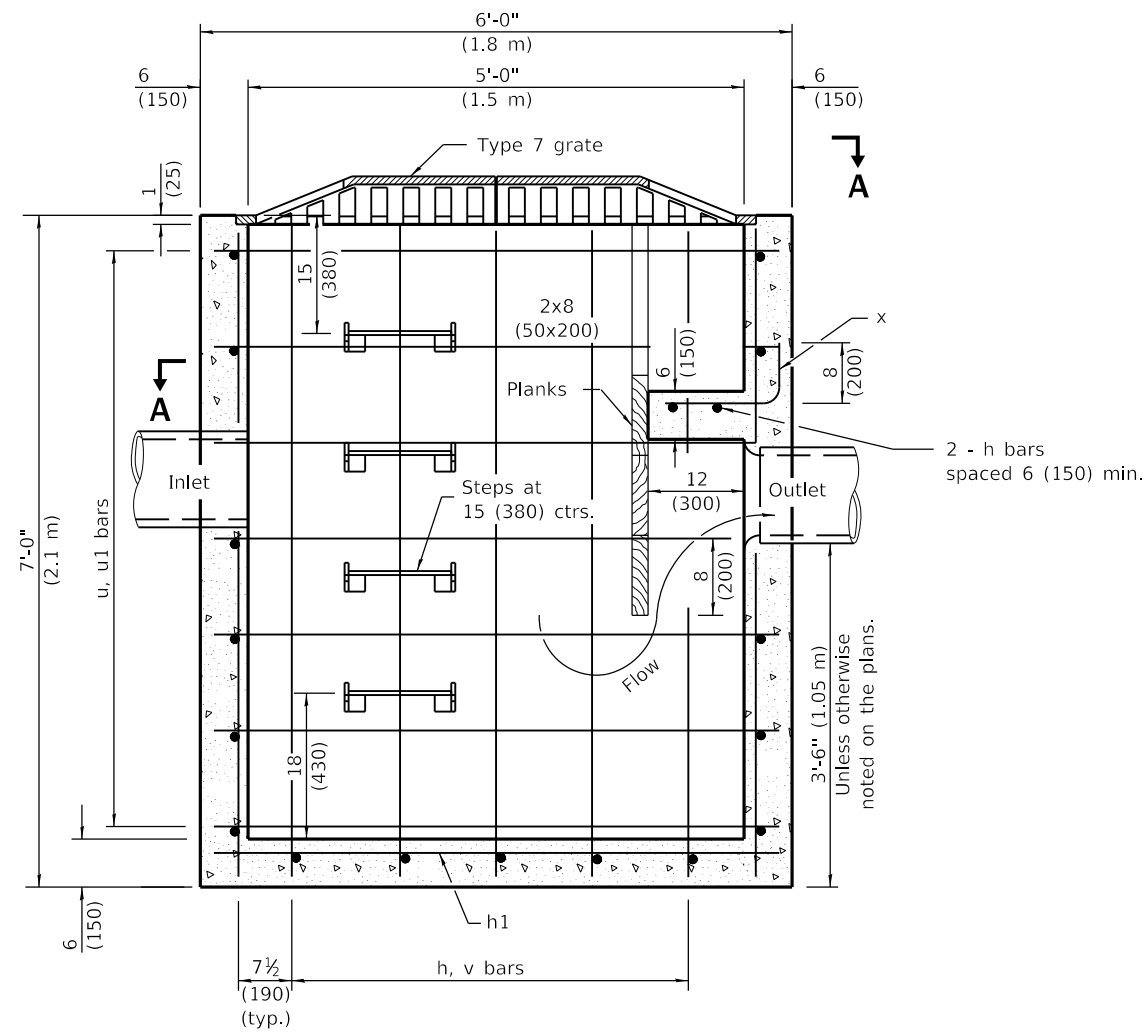

ELEVATION

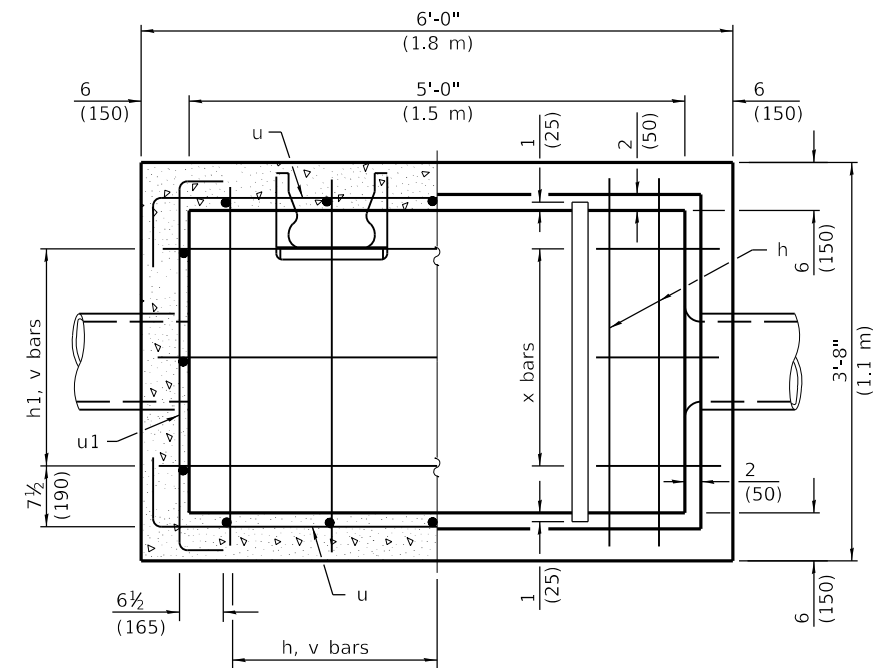

SECTION A-A
(Grating removed to show plan of baffles.)

**MATERIALS REQUIRED FOR ONE (1)
TYPE B CATCH BASIN**

Bar	Qty.	Size	Shape	Length
h	7	No. 4 (No. 13)	—	3'-5" (1.02 m)
h1	3	No. 4 (No. 13)	—	5'-9" (1.72 m)
u	14	No. 4 (No. 13)	┌	7'-0" (2.10 m)
u1	14	No. 4 (No. 13)	┌	4'-6" (1.35 m)
v	16	No. 4 (No. 13)	—	6'-9" (2.02 m)
x	3	No. 4 (No. 13)	┌	1'-11" (580)
Concrete			cu. yd. (m ³)	2.5 (1.90)
Reinforcement bars			lbs. (kg)	210 (95)

All bars shall be at 12 (300) centers unless otherwise shown. Reinforcement bar clearance shall be 1½ (40).

GENERAL NOTES

See Standard 602701 for details of steps.

All dimensions are in inches (millimeters) unless otherwise shown.

DATE	REVISIONS
1-1-13	Revised and relocated steps.
1-1-11	Added additional bar identification.

**CATCH BASIN
TYPE B**

STANDARD 602006-04

Illinois Department of Transportation

PASSED January 1, 2013
Michael Beard
 ENGINEER OF POLICY AND PROCEDURES

APPROVED January 1, 2013
[Signature]
 ENGINEER OF DESIGN AND ENVIRONMENT

ISSUED 1-1-97

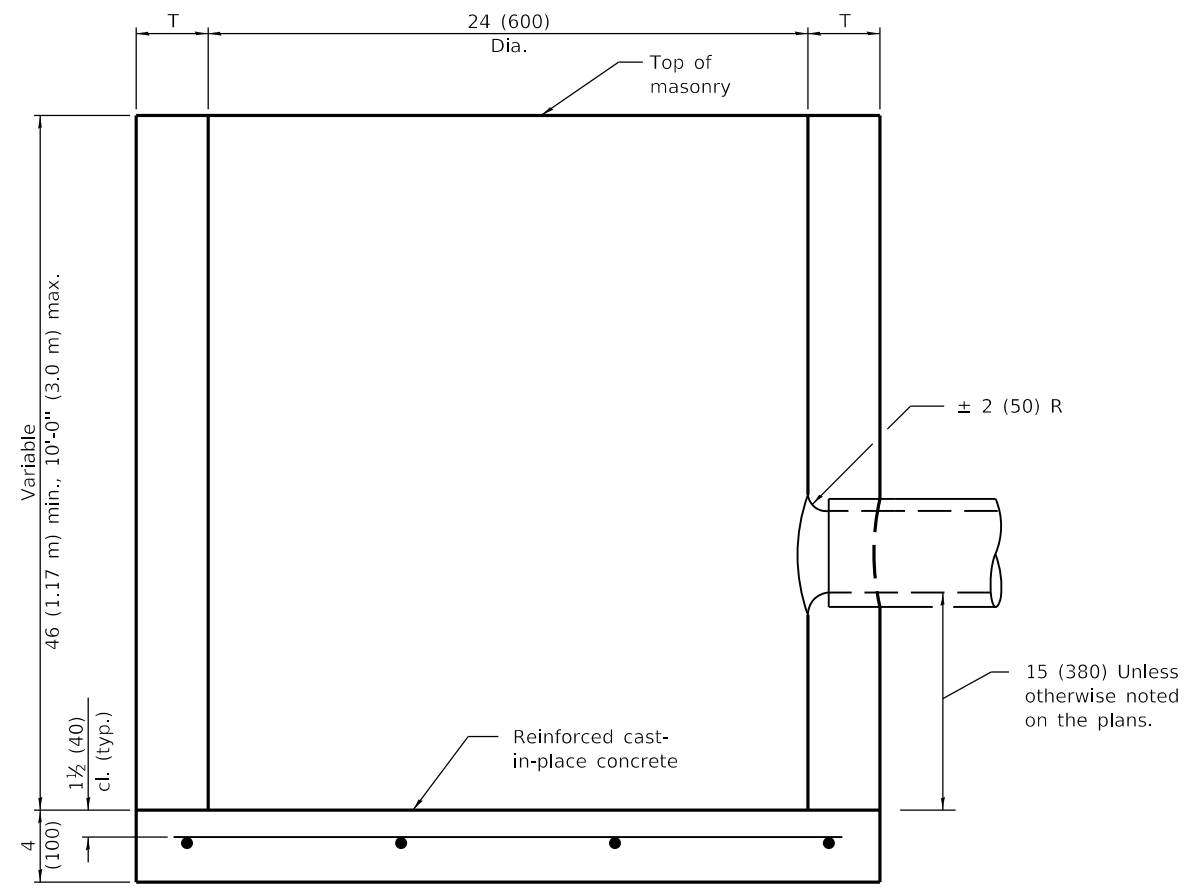

ALTERNATE MATERIALS FOR WALLS	T (min)
Precast Reinforced Concrete Section	3 (75)
Concrete Masonry Unit	5 (125)
Cast-in-Place Concrete	6 (150)
Brick Masonry	8 (200)

ELEVATION

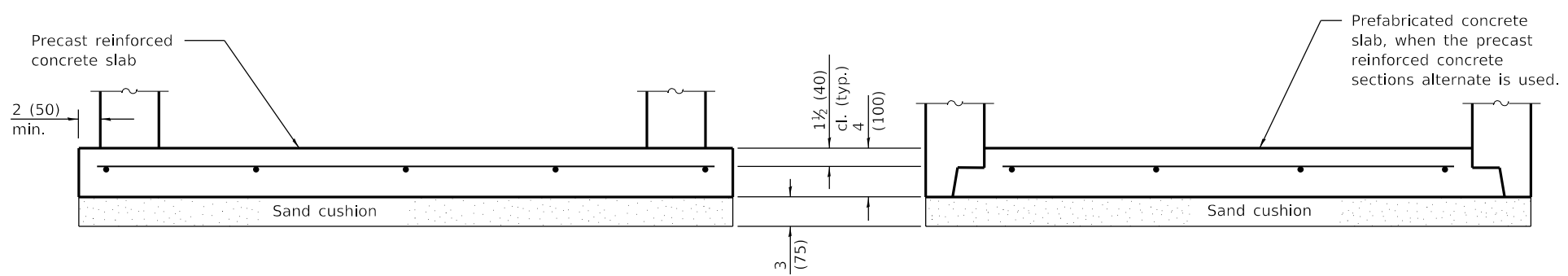

ALTERNATE BOTTOM SLAB

GENERAL NOTES

Bottom slabs shall be reinforced with a minimum of 0.27 sq. in./ft. (570 sq. mm/m) in both directions with a maximum spacing of 9 (230).

Bottom slabs may be connected to the riser as determined by the fabricator; however, only a single row of reinforcement around the perimeter may be utilized.

All dimensions are in inches (millimeters) unless otherwise shown.

DATE	REVISIONS
1-1-11	Detailed rein. in slabs.
	Added max. limit to height.
	Added general notes.
1-1-09	Switched units to
	English (metric).

CATCH BASIN TYPE C

STANDARD 602011-02

Illinois Department of Transportation

PASSED January 1, 2011
Michael Beard
 ENGINEER OF POLICY AND PROCEDURES

APPROVED January 1, 2011
[Signature]
 ENGINEER OF DESIGN AND ENVIRONMENT

ISSUED 1-1-97

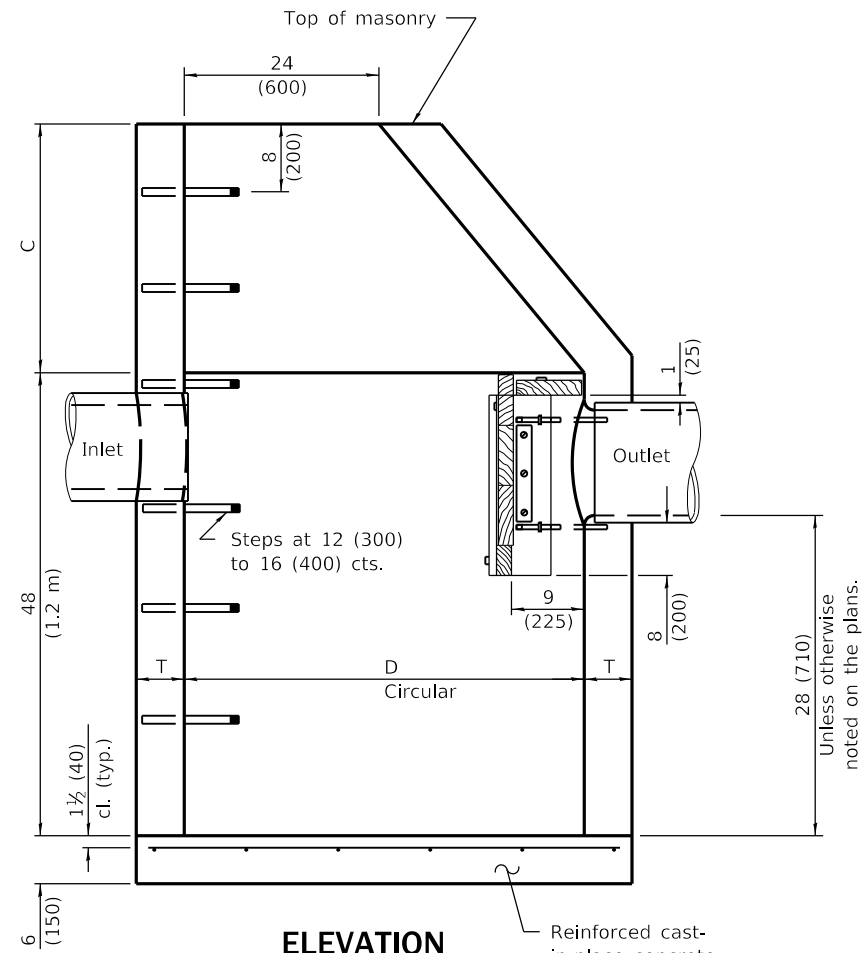

ELEVATION

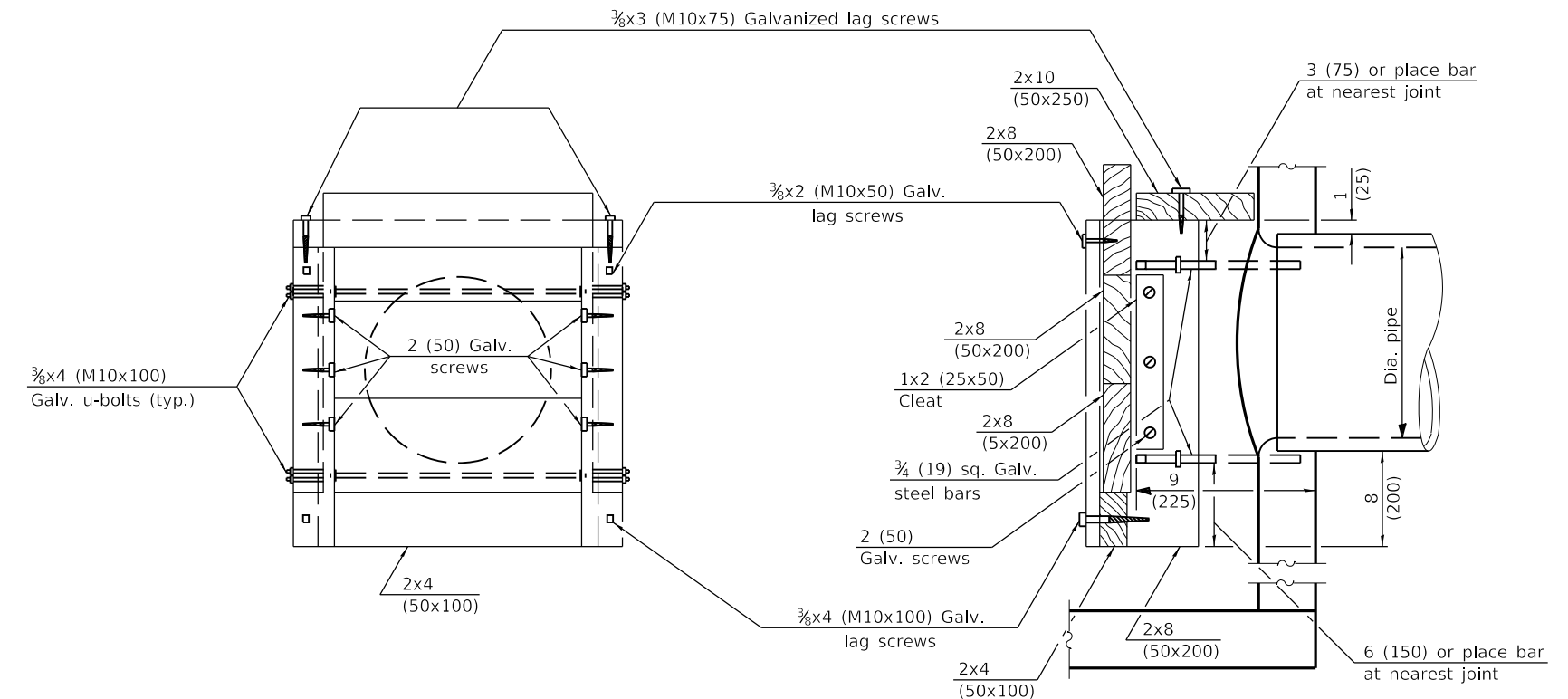

ELEVATION

SECTION A-A

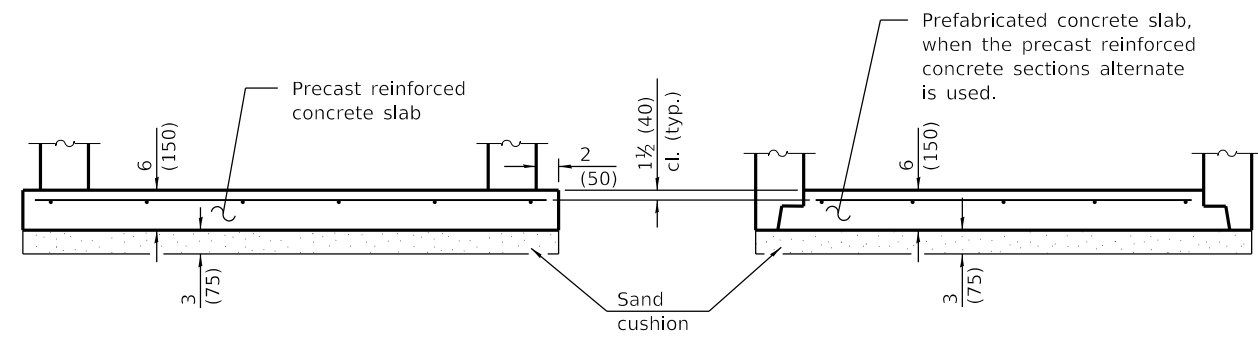

ALTERNATE BOTTOM SLAB

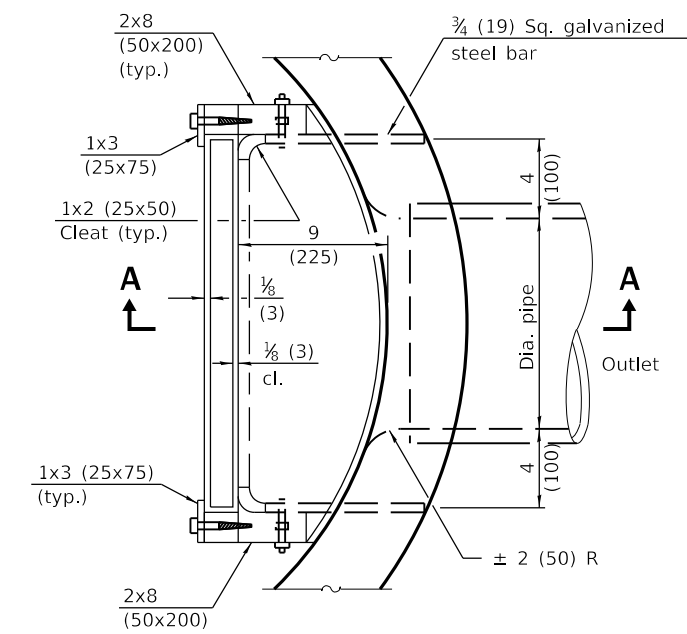

PLAN

ALTERNATE MATERIALS FOR WALLS	D	C*	T (min.)
Concrete Masonry Unit	36 (900) 4'-0" (1.20 m)	15 (380) 30 (760)	5 (125) 5 (125)
Brick Masonry	36 (900) 4'-0" (1.20 m)	15 (380) 30 (760)	8 (200) 8 (200)
Precast Reinforced Concrete Section	36 (900) 4'-0" (1.20 m)	15 (380) 30 (760)	3 (75) 4 (100)
Cast-in-Place Concrete	36 (900) 4'-0" (1.20 m)	15 (380) 30 (760)	6 (150) 6 (150)

* For precast reinforced concrete sections, dimension "C" may vary from the dimension given to plus 6 (150).

GENERAL NOTES

Bottom slabs shall be reinforced with a minimum of 0.20 sq. in./ft. (420 sq. mm/m) in both directions with a maximum spacing of 12 (300).

Bottom slabs may be connected to the riser as determined by the fabricator; however, only a single row of reinforcement around the perimeter may be utilized.

See Standard 602701 for details of steps.

See Standard 602601 for optional precast reinforced concrete flat slab top.

All dimensions are in inches (millimeters) unless otherwise shown.

DATE	REVISIONS
1-1-11	Detailed reinforcement in slabs. Revised general notes.
1-1-09	Switched units to English (metric).

CATCH BASIN TYPE D

STANDARD 602016-02

Illinois Department of Transportation

PASSED January 1, 2011
Michael Beard
 ENGINEER OF POLICY AND PROCEDURES

APPROVED January 1, 2011
[Signature]
 ENGINEER OF DESIGN AND ENVIRONMENT

ISSUED 1-1-97

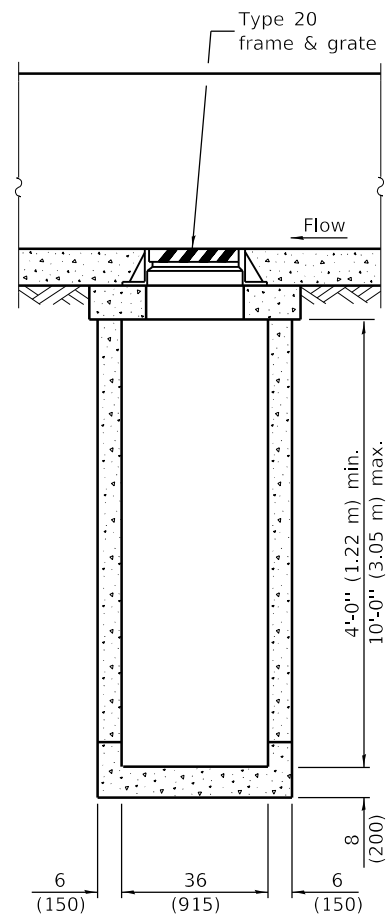

FRONT ELEVATION - TYPE 4

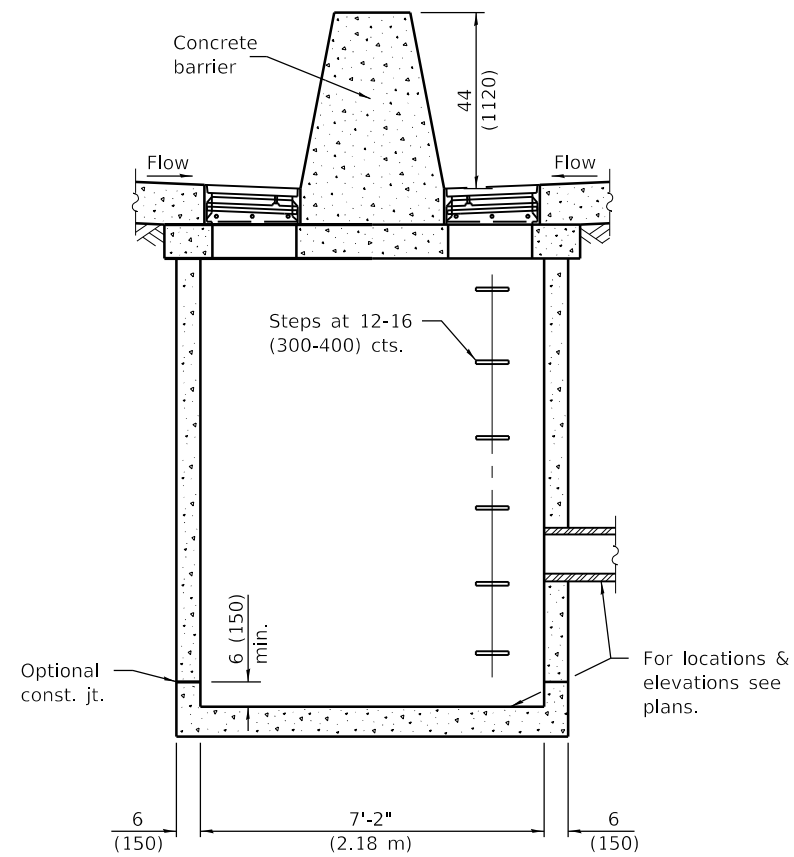

SIDE ELEVATION - TYPE 4 & 5

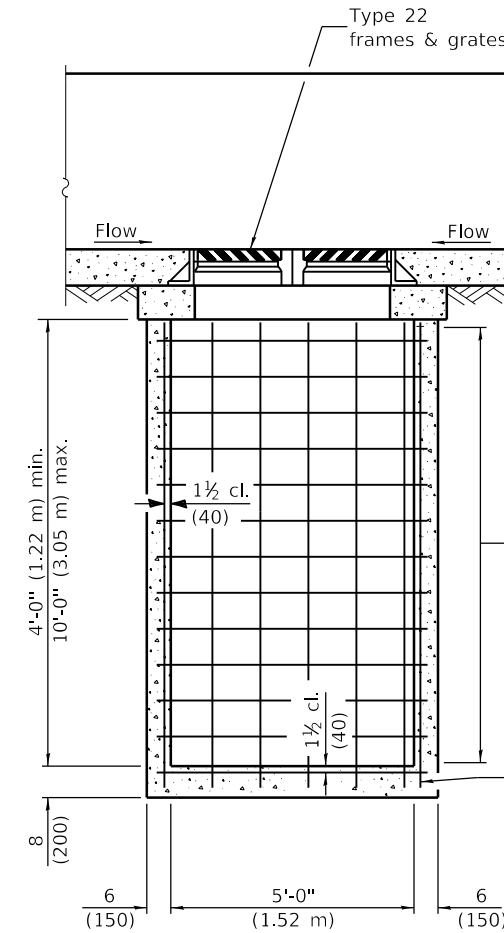

FRONT ELEVATION - TYPE 5

For 4'-0" (1.22 m) to 8'-0" (2.44 m) use No. 5 (No. 16) bars at 8 (200) cts. (all sides).
Over 8'-0" (2.44 m) to 10'-0" use No. 5 (No. 16) bars at 7 (175) cts. (all sides).

No. 5 (No. 16) Bars at 12 (300) cts. (all sides)

GENERAL NOTES

These structures are for use with concrete barrier, double face, 44 (1120) height (Standard 637006).

The reinforcement shown in the front elevation of the Type 5 is typical for both elevations of all types.

See Standard 602701 for details of steps.

Exposed edges shall be beveled 3/4 (19).

All dimensions are in inches (millimeters) unless otherwise shown.

Illinois Department of Transportation

PASSED January 1, 2021
Michael Bond
ENGINEER OF POLICY AND PROCEDURES

APPROVED January 1, 2021
J. C. Egan
ENGINEER OF DESIGN AND ENVIRONMENT

ISSUED 4-1-04

DATE	REVISIONS
1-1-21	Revised openings in lid to fit the 36 (915) width of the revised concrete median barrier.
1-1-19	Deleted Type 6 and revised Types 4 and 5 to fit with 44 (1120) height, constant slope barrier.

**DRAINAGE STRUCTURES
TYPES 4 & 5**

(Sheet 1 of 2)

STANDARD 602106-03

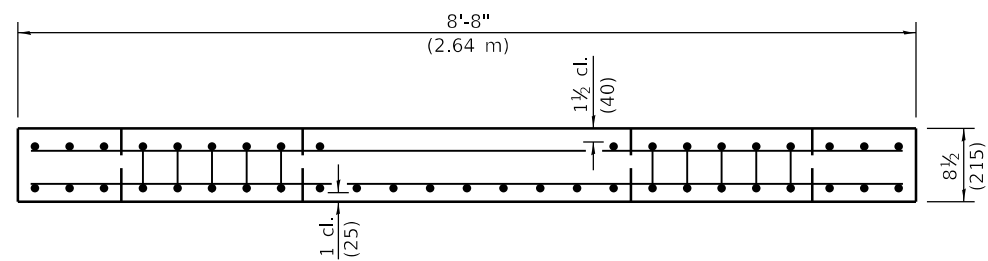
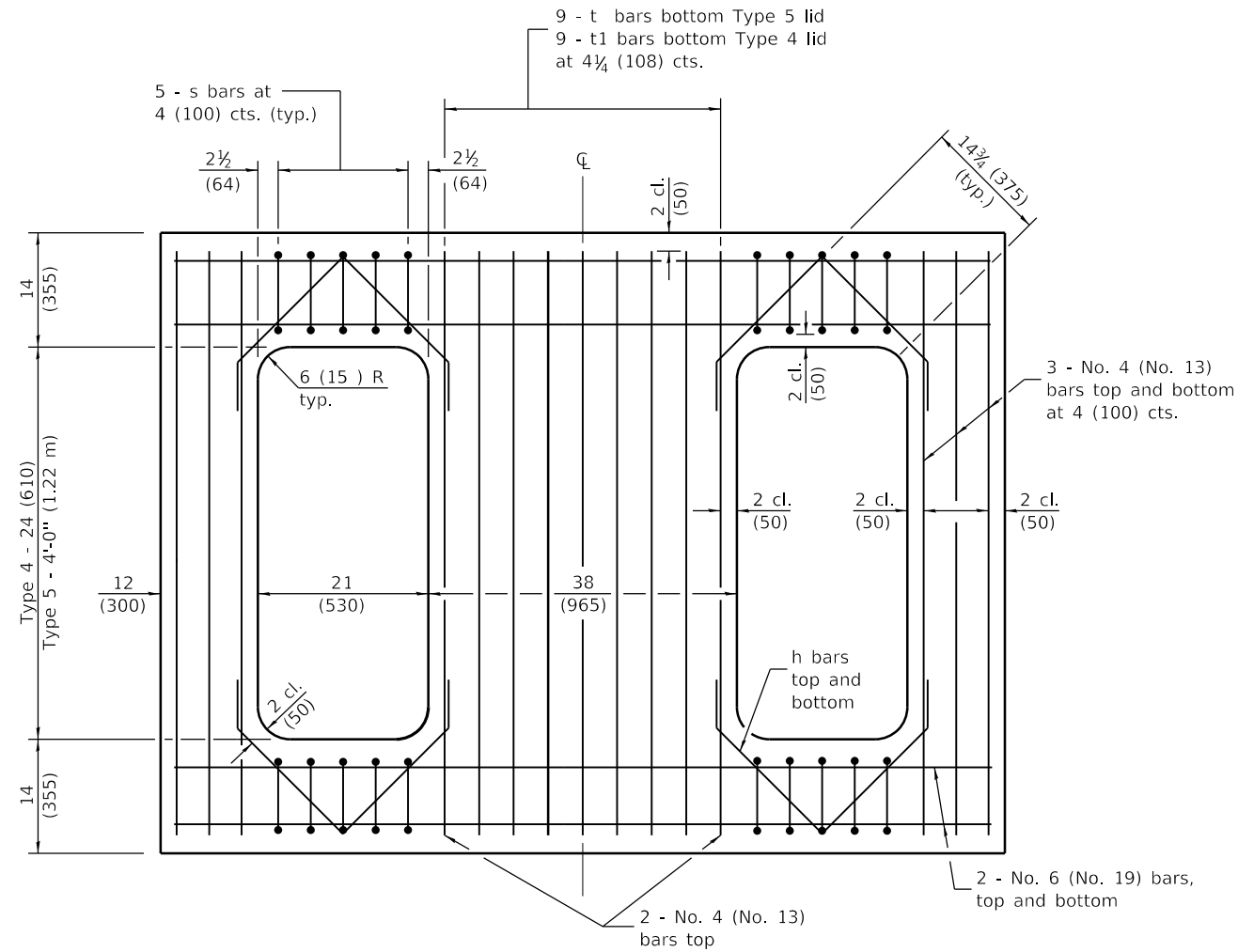

REINFORCED LID - TYPE 4 & 5

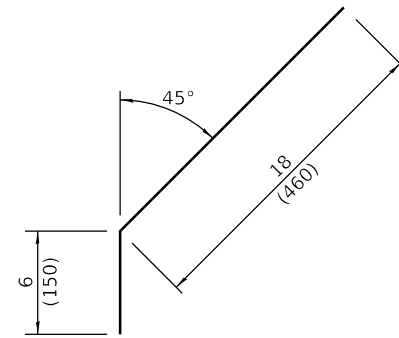

No. 4 (No. 13) Bar h

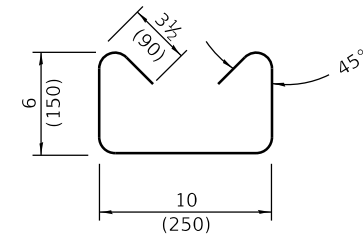

No. 3 (No. 10) Bar s

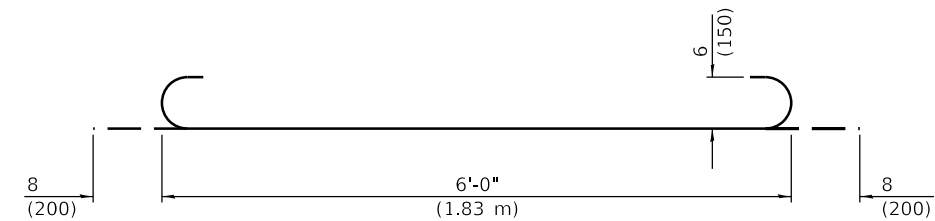

No. 6 (No. 19) Bar t

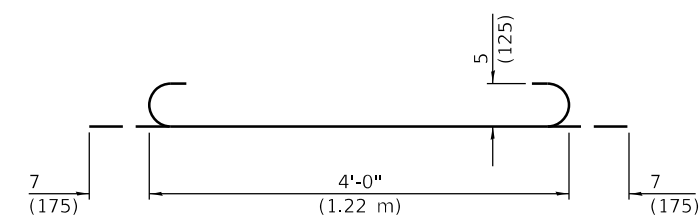

No. 5 (No. 16) Bar t1

Illinois Department of Transportation

PASSED January 1, 2021
Michael Bond
 ENGINEER OF POLICY AND PROCEDURES

APPROVED January 1, 2021
J. E. Egan
 ENGINEER OF DESIGN AND ENVIRONMENT

ISSUED 4-1-04

**DRAINAGE STRUCTURES
 TYPES 4 & 5**

(Sheet 2 of 2)

STANDARD 602106-03

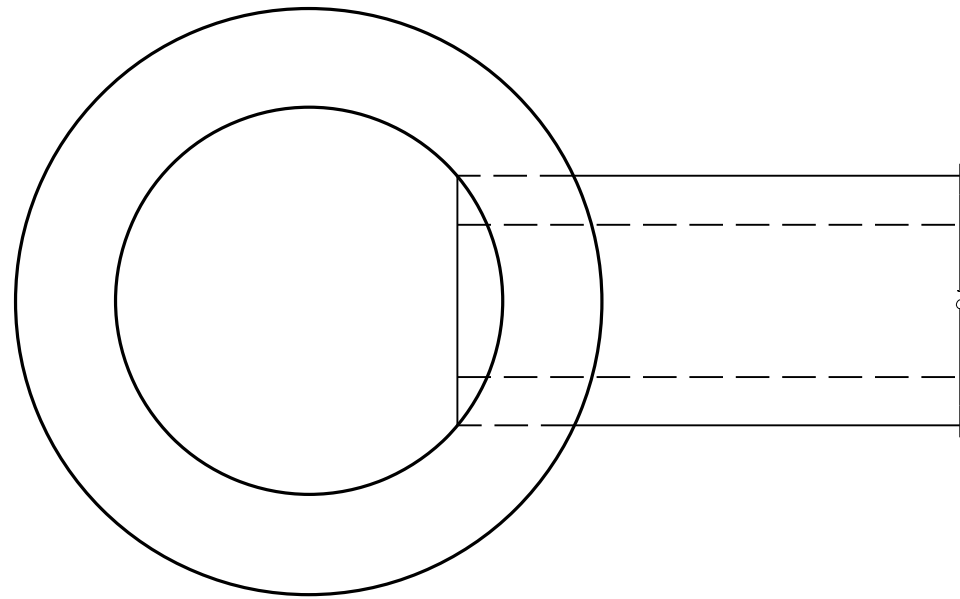

PLAN

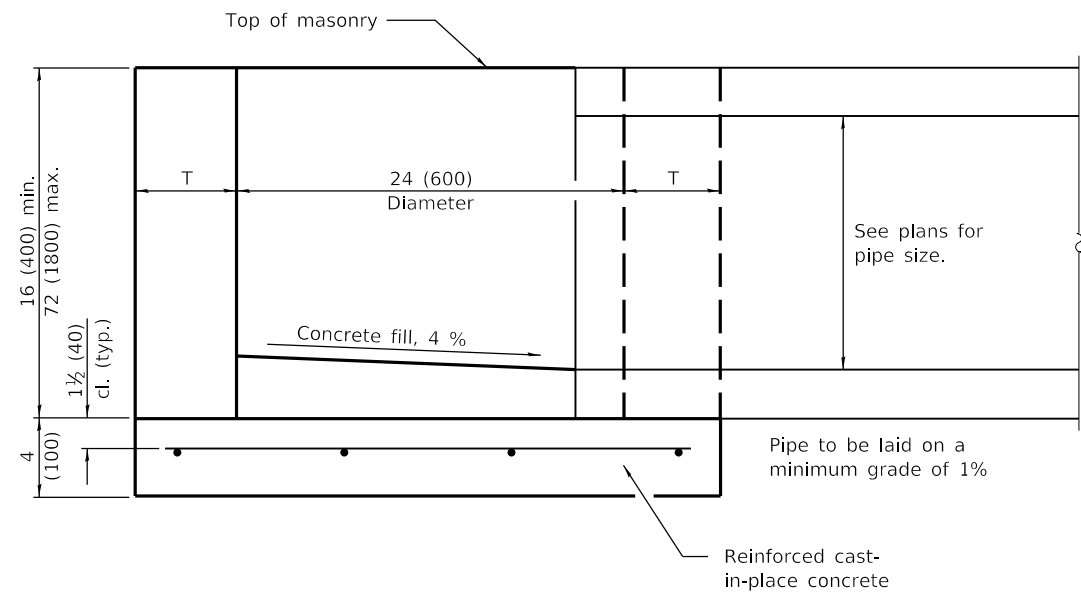

ELEVATION

ALTERNATE MATERIALS FOR WALLS	T
BRICK MASONRY	8 (200)
CAST-IN-PLACE CONCRETE	6 (150)
CONCRETE MASONRY UNIT	5 (125)
PRECAST REINFORCED CONCRETE SECTION	3 (75)

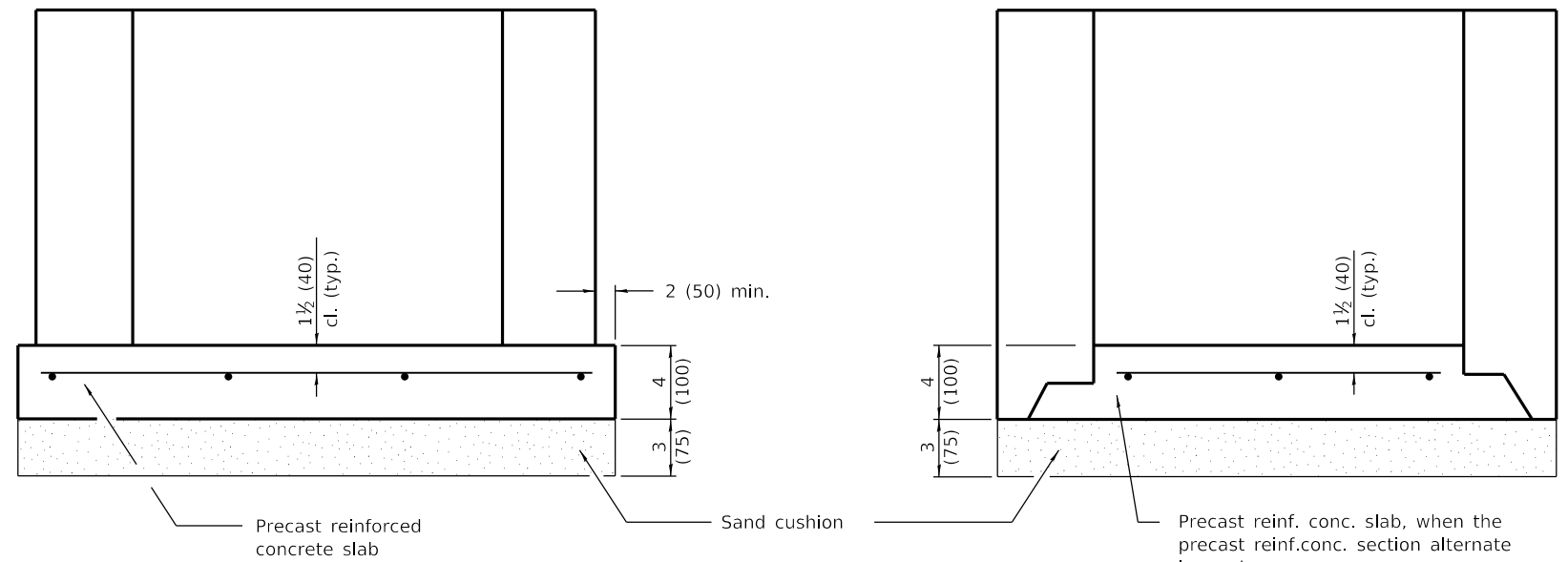

ALTERNATE METHODS

GENERAL NOTES

Bottom slabs shall be reinforced with a minimum of 0.24 sq. in./ft. (510 sq. mm/m) in both directions with a maximum spacing of 10 (250).

Bottom slabs may be connected to the riser as determined by the fabricator; however, only a single row of reinforcement around the perimeter may be utilized.

All dimensions are in inches (millimeters) unless otherwise shown.

DATE	REVISIONS
1-1-14	Increased height to 72 (1800) maximum.
1-1-11	Detailed rein. in slabs.
	Added max. limit to height.
	Added general notes.

INLET - TYPE A

STANDARD 602301-04

Illinois Department of Transportation

PASSED January 1, 2014
Michael Beard
 ENGINEER OF POLICY AND PROCEDURES

APPROVED January 1, 2014
[Signature]
 ENGINEER OF DESIGN AND ENVIRONMENT

ISSUED 1-1-97

* For precast reinforced concrete sections, this dimension may vary from the dimension given to plus 6 (150).

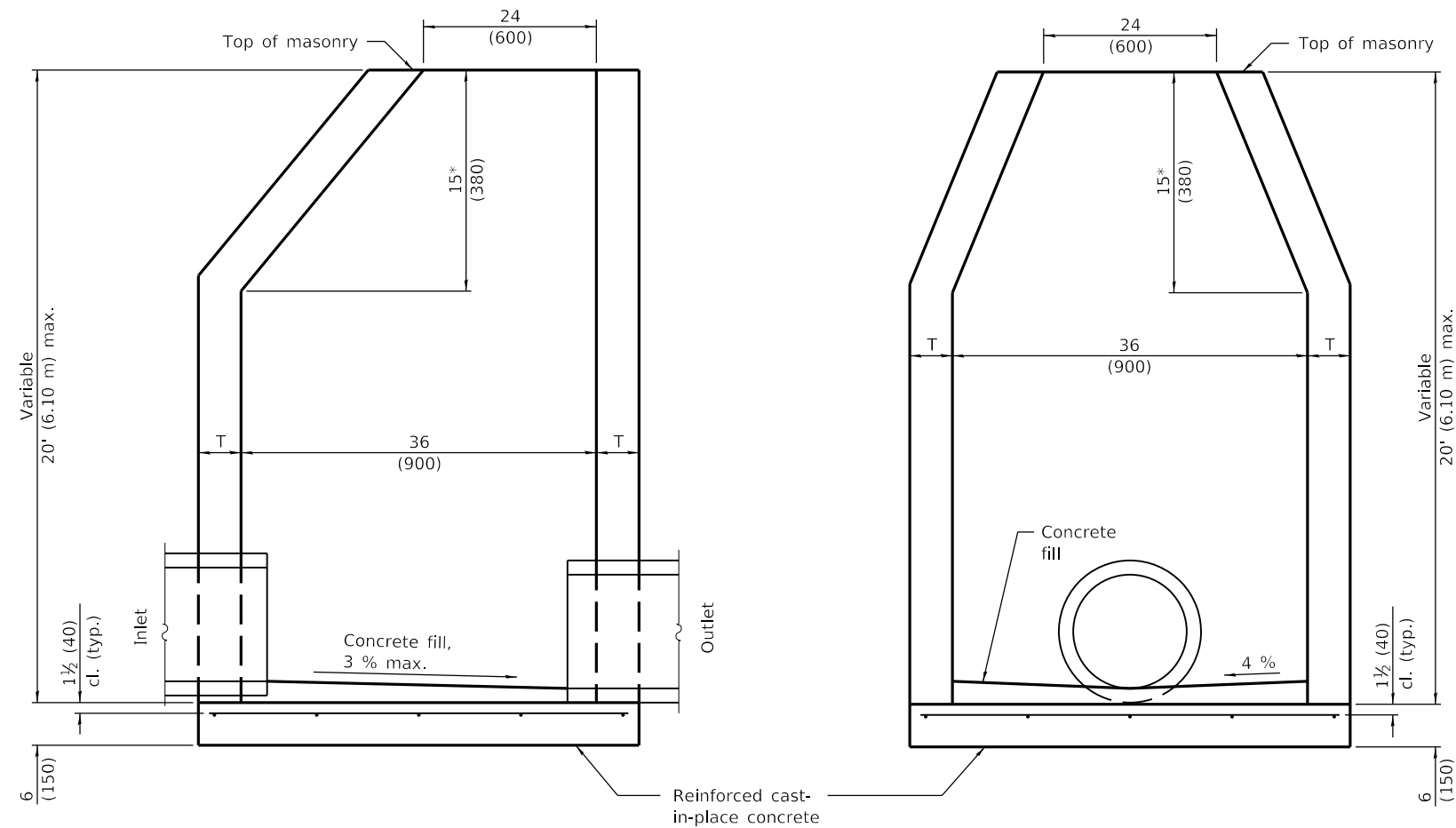

ELEVATION - ECCENTRIC

ELEVATION - CONCENTRIC

ALTERNATE MATERIALS FOR WALLS	T (min.)
Concrete Masonry Unit	5 (125)
Brick Masonry	8 (200)
Precast Reinforced Concrete Section	3 (75)
Cast-in-Place Concrete	6 (150)

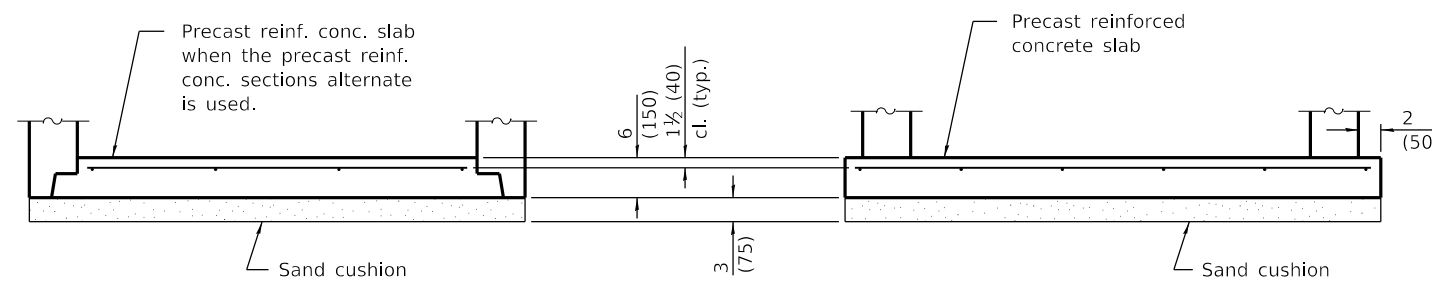

ALTERNATE BOTTOM SLAB

GENERAL NOTES

Bottom slabs shall be reinforced with a minimum of 0.20 sq. in./ft. (420 sq. mm/m) in both directions with a maximum spacing of 12 (300).

Bottom slabs may be connected to the riser as determined by the fabricator; however, only a single row of reinforcement around the perimeter may be utilized.

See Standard 602601 for optional Precast Reinforced Concrete Flat Slab Top.

All dimensions are in inches (millimeters) unless otherwise shown.

DATE	REVISIONS
1-1-11	Detailed rein. in slabs.
	Added max. limit to height.
	Revised general notes.
1-1-09	Switched units to
	English (metric).

INLET - TYPE B

STANDARD 602306-03

Illinois Department of Transportation

PASSED January 1, 2011
Michael Beard
 ENGINEER OF POLICY AND PROCEDURES

APPROVED January 1, 2011
Scott Schick
 ENGINEER OF DESIGN AND ENVIRONMENT

ISSUED 1-1-97

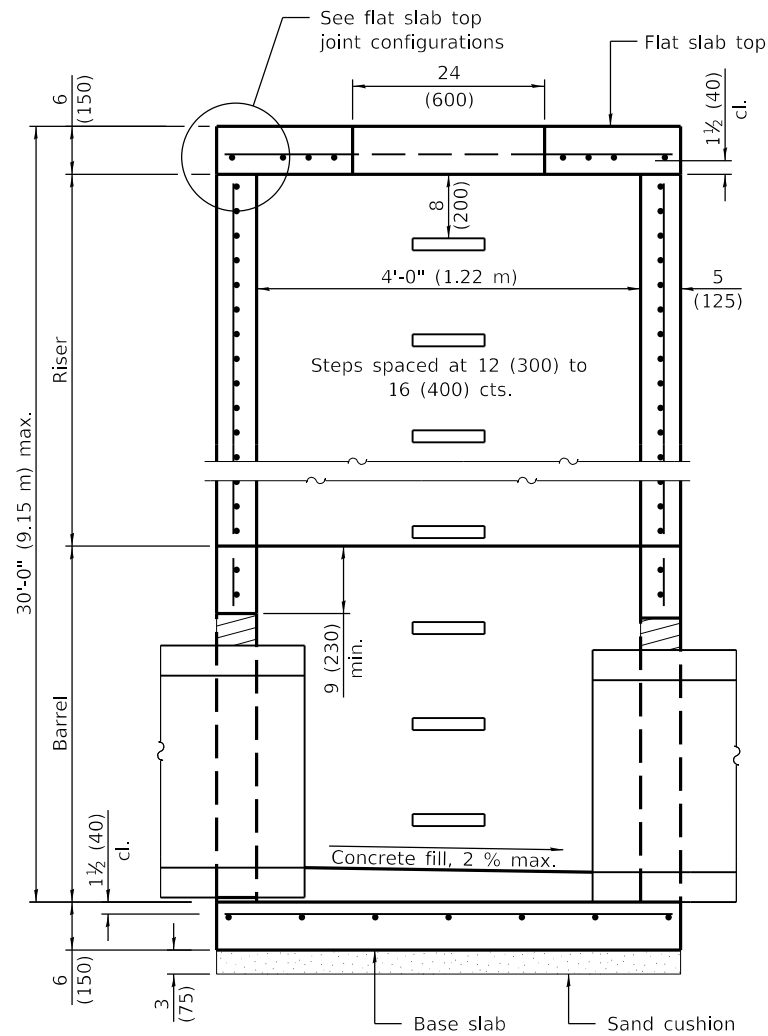

SECTION PARALLEL TO PIPE
(Without conical top riser)

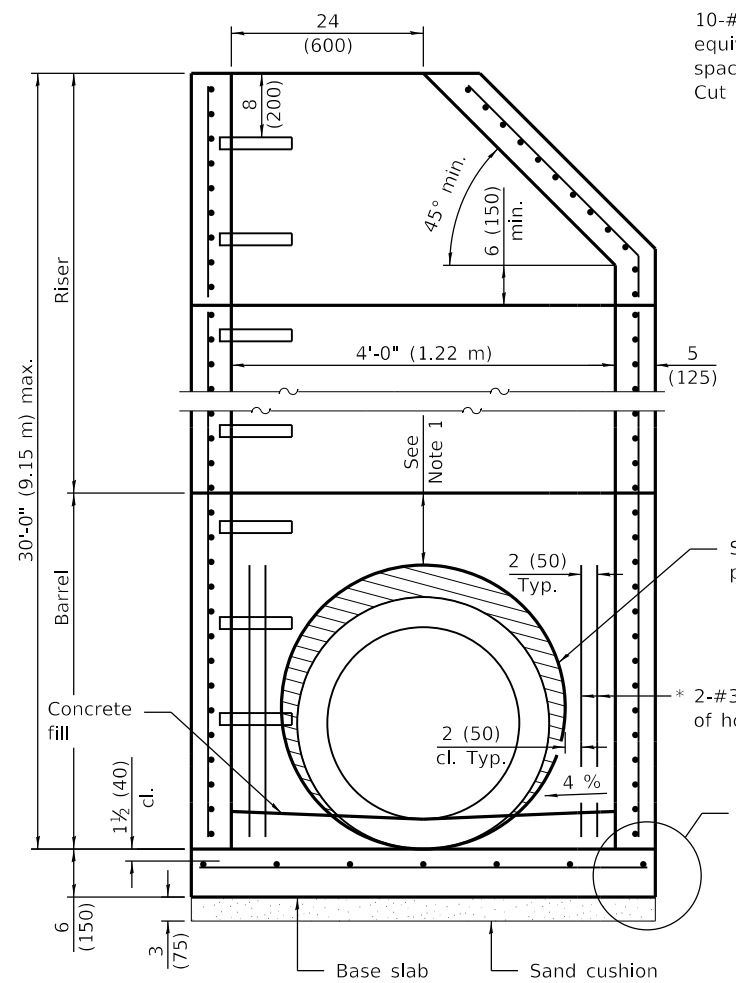

SECTION PERPENDICULAR TO PIPE
(With conical top riser)

* As an alternate, the barrel wall reinforcement may be reduced to riser wall reinforcement with #3 (#10) bars placed around the pipe penetration holes as shown. This option may be utilized when the pipe penetration holes are formed as opposed to cored.

GEOMETRIC LIMITS FOR PIPE PENETRATION HOLES

- Note 1: A minimum of 9 (230) of monolithic reinforced concrete shall be maintained above pipe penetration holes > 24 (600).
- Note 2: A minimum 12 (300) inside arc length of reinforced concrete shall be maintained between pipe penetration holes > 15 (380).
- Note 3: A maximum of 60 percent of the inside perimeter of the reinforced concrete manhole walls may be removed.
- Note 4: Horizontal joints that intersect pipe penetration holes > 15 (380) shall have one joint splice for every location around the perimeter of the joint where the inside arc length between pipe penetration holes is < 24 (600). See joint splice detail.
- Note 5: The recommended pipe penetration hole is equal to the O.D. of the pipe plus 4 (100).
- Note 6: Only pipe penetration holes ≤ 15 (380) are allowed in riser sections.

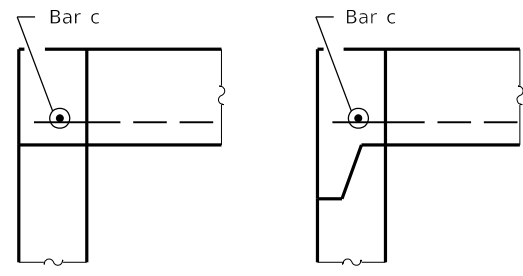

FLAT SLAB TOP JOINT CONFIGURATIONS
(Shown at access hole)

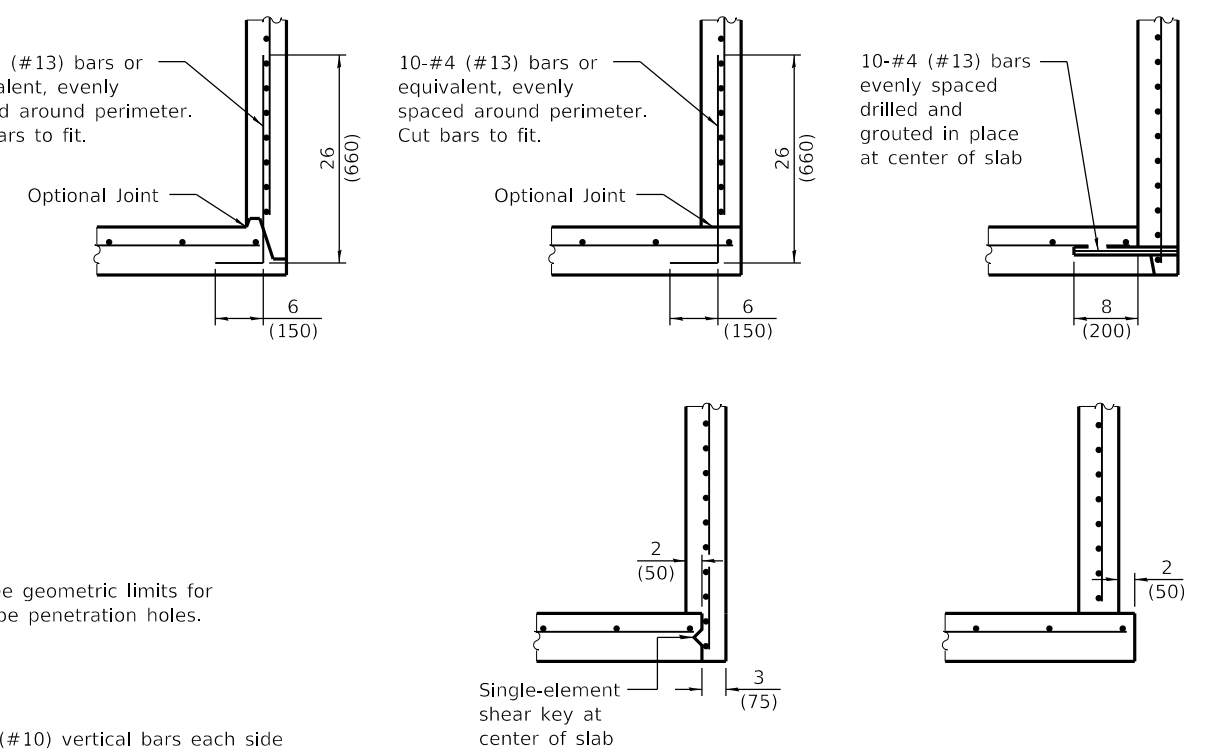

BASE SLAB JOINT CONFIGURATIONS

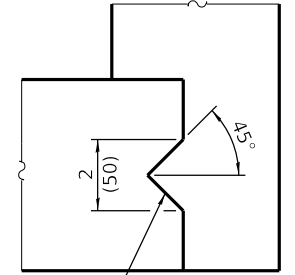

Single-element shear key at center of slab
SHEAR KEY GEOMETRY
(Reinforcement not shown for clarity)

GENERAL NOTES

The manufacturer shall ensure that all precast manhole sections are additionally reinforced where required to resist damage from handling, shipping and installation stresses.

Lifting holes shall be located in the sections as per the manufacturer's recommendations.

See Standard 602701 for details of manhole steps.

All dimensions are in inches (millimeters) unless otherwise noted.

DATE	REVISIONS
1-1-21	Revised Note 1 and lifting hole general note.
3-1-19	Moved wall reinforcement from inside face to middle.

PRECAST MANHOLE TYPE A
4' (1.22 m) DIAMETER
(Sheet 1 of 2)

STANDARD 602401-07

Illinois Department of Transportation

PASSED January 1, 2021
Michael Bond
ENGINEER OF POLICY AND PROCEDURES

APPROVED January 1, 2021
John E. G...
ENGINEER OF DESIGN AND ENVIRONMENT

ISSUED 1-1-97

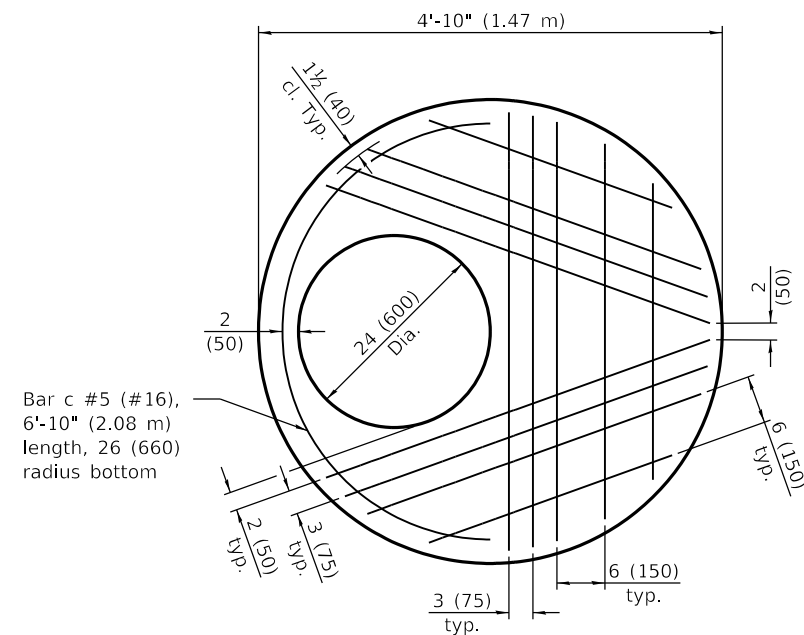

PLAN - FLAT SLAB TOP

(Showing layout of reinforcement bars and c bars)

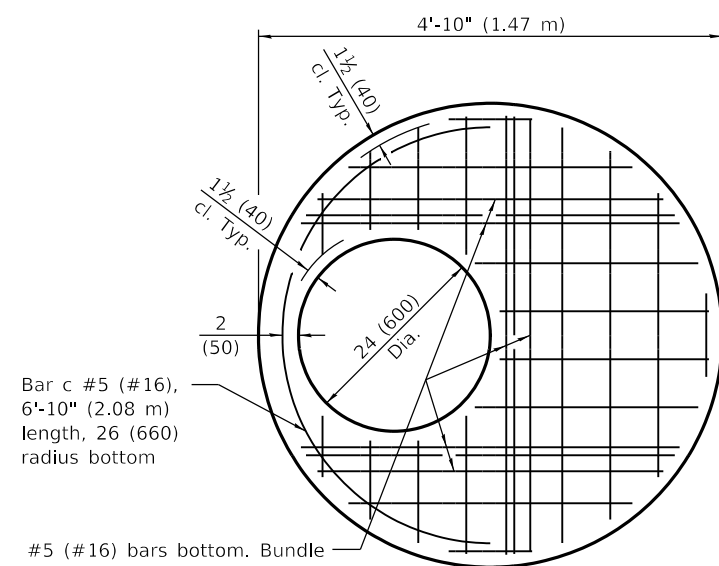

PLAN - FLAT SLAB TOP

(Showing layout of welded wire reinforcement and c bars)

Bar c #5 (#16), 6'-10" (2.08 m) length, 26 (660) radius bottom

#5 (#16) bars bottom. Bundle first bar with closest WWR bar to the opening and place second bar ±3 (75) away.

1 (25) Ø Threaded rods with 2 1/4 x 2 1/4 x 3/16 (55x55x8) washers under each nut. All nuts shall be brought to a snug tight condition. Holes in the walls may be drilled using core bits in lieu of formed holes.

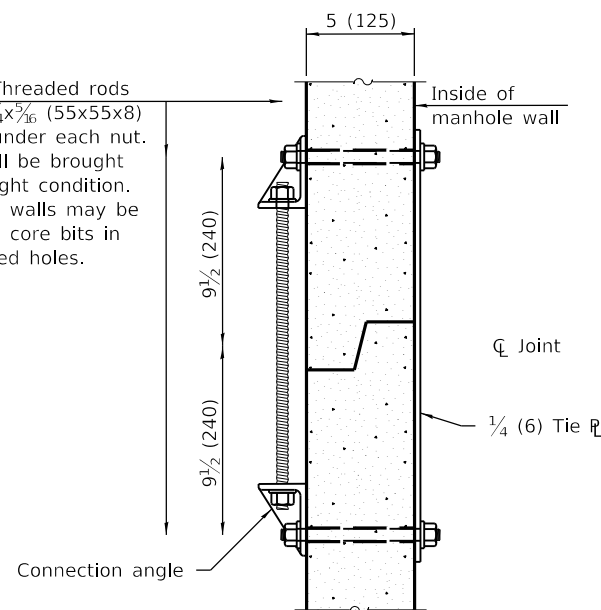

JOINT SPLICE

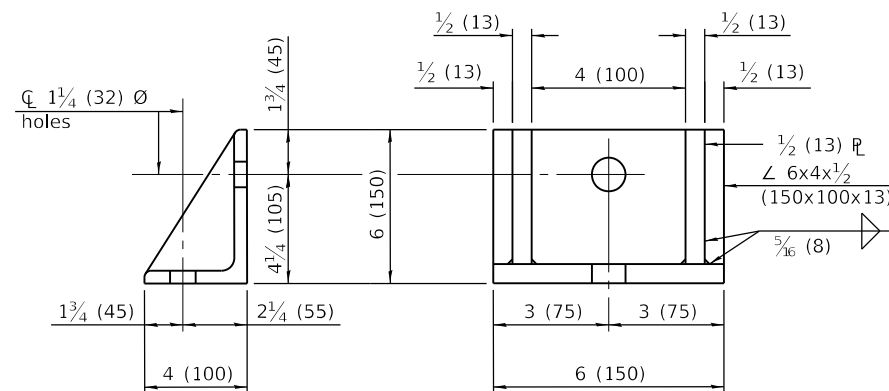

CONNECTION ANGLE

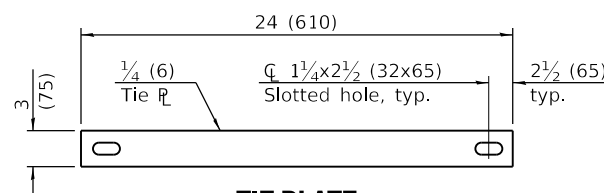

TIE PLATE

FLAT SLAB TOP REINFORCEMENT

Location	WWR (each direction)		Rebar		
	A _s (min.)	Spacing (max.)	A _s (min.)	Spacing (max.)	Bar Size
Bottom Mat	** 0.62 sq. in./ft. (1312 sq. mm/m)	6 (150)	See plan view for rebar orientation and spacing and this table for bar size		#5 (#16)

** Only one layer of WWR permitted to avoid congestion.

WALL REINFORCEMENT

Location	Orientation	WWR or Rebar	
		A _s (min.)	Spacing (max.)
Riser	Circumferential	0.12 sq. in./ft. (254 sq. mm/m)	6 (150)
	Vertical	0.045 sq. in./ft. (95 sq. mm/m)	8 (200)
Barrel	Circumferential	0.12 sq. in./ft. (254 sq. mm/m)	6 (150)
	Vertical	0.16 sq. in./ft. (339 sq. mm/m)	4 (100)

BASE SLAB REINFORCEMENT

Location	Total Height	WWR or Rebar (each direction)	
		A _s (min.)	Spacing (max.)
Top Mat	≤ 20 ft. (6.10 m)	0.24 sq. in./ft. (508 sq. mm/m)	10 (250)
	> 20 ft. (6.10 m)	0.24 sq. in./ft. (508 sq. mm/m)	10 (250)

Illinois Department of Transportation

PASSED January 1, 2021
Michael Bond
 ENGINEER OF POLICY AND PROCEDURES

APPROVED January 1, 2021
J. E. ...
 ENGINEER OF DESIGN AND ENVIRONMENT

ISSUED 1-1-97

PRECAST MANHOLE TYPE A
4' (1.22 m) DIAMETER
 (Sheet 2 of 2)

STANDARD 602401-07

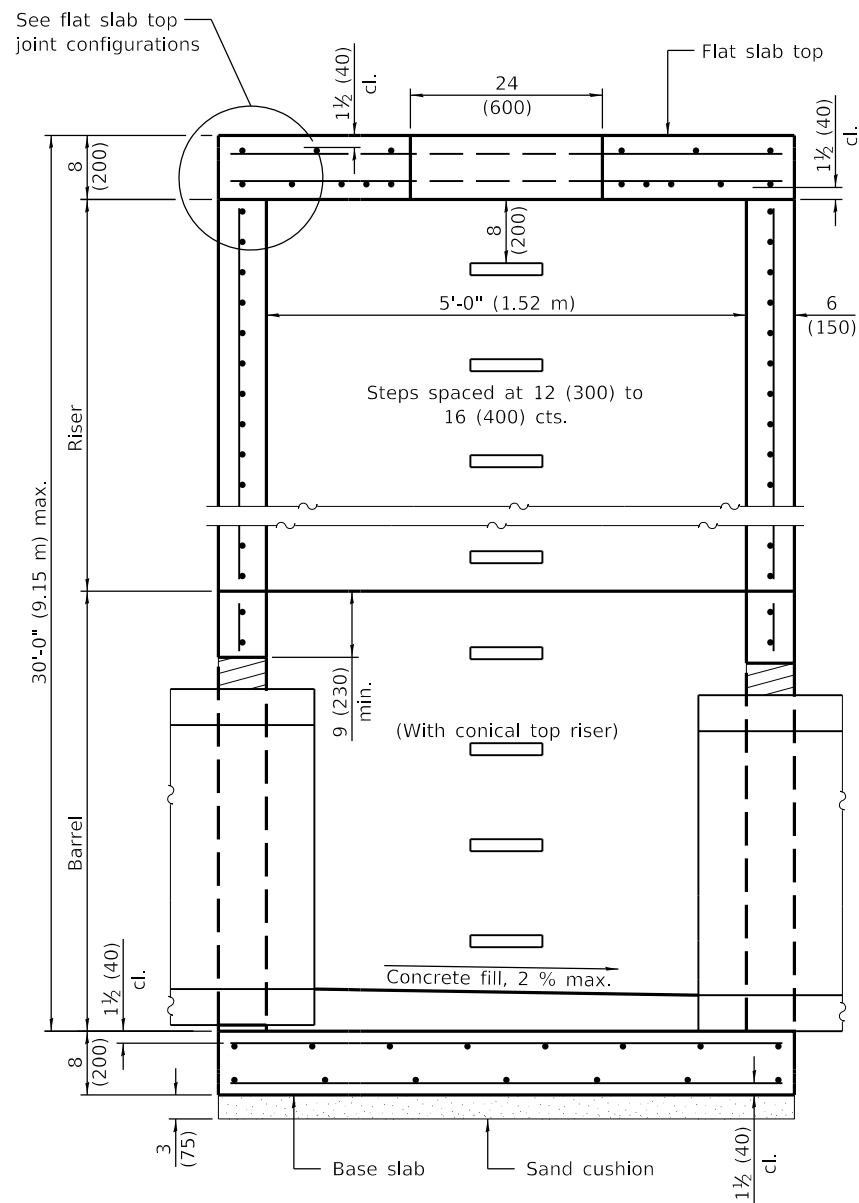

SECTION PARALLEL TO PIPE
(Without conical top riser)

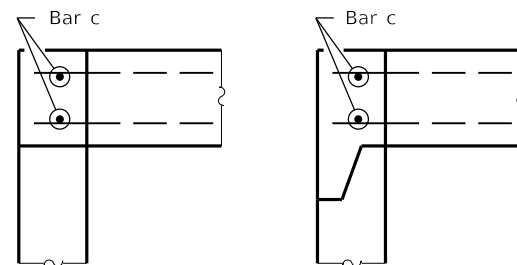

FLAT SLAB TOP JOINT CONFIGURATIONS
(Shown at access hole)

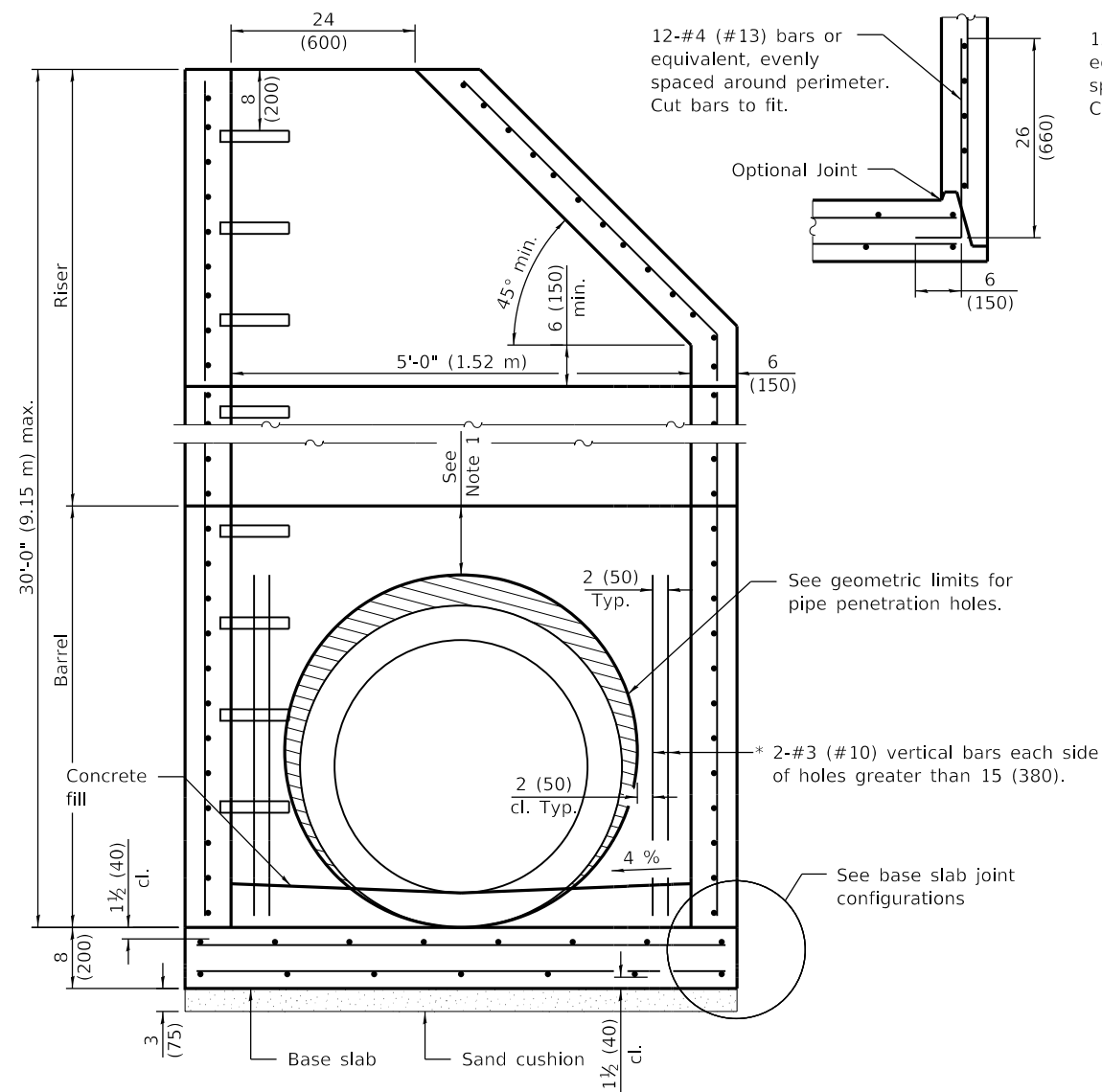

SECTION PERPENDICULAR TO PIPE
(With conical top riser)

* As an alternate, the barrel wall reinforcement may be reduced to riser wall reinforcement with #3 (#10) bars placed around the pipe penetration holes as shown. This option may be utilized when the pipe penetration holes are formed as opposed to cored.

GEOMETRIC LIMITS FOR PIPE PENETRATION HOLES

- Note 1: A minimum of 9 (230) of monolithic reinforced concrete shall be maintained above pipe penetration holes > 32 (810).
- Note 2: A minimum 12 (300) inside arc length of reinforced concrete shall be maintained between pipe penetration holes > 15 (380).
- Note 3: A maximum of 60 percent of the inside perimeter of the reinforced concrete manhole walls may be removed.
- Note 4: Horizontal joints that intersect pipe penetration holes > 15 (380) shall have one joint splice for every location around the perimeter of the joint where the inside arc length between pipe penetration holes is < 24 (600). See joint splice detail.
- Note 5: The recommended pipe penetration hole is equal to the O.D. of the pipe plus 4 (100).
- Note 6: Only pipe penetration holes ≤ 15 (380) are allowed in riser sections.

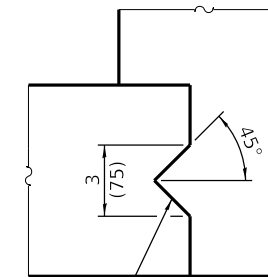

Single-element shear key at center of slab

SHEAR KEY GEOMETRY
(Reinforcement not shown for clarity)

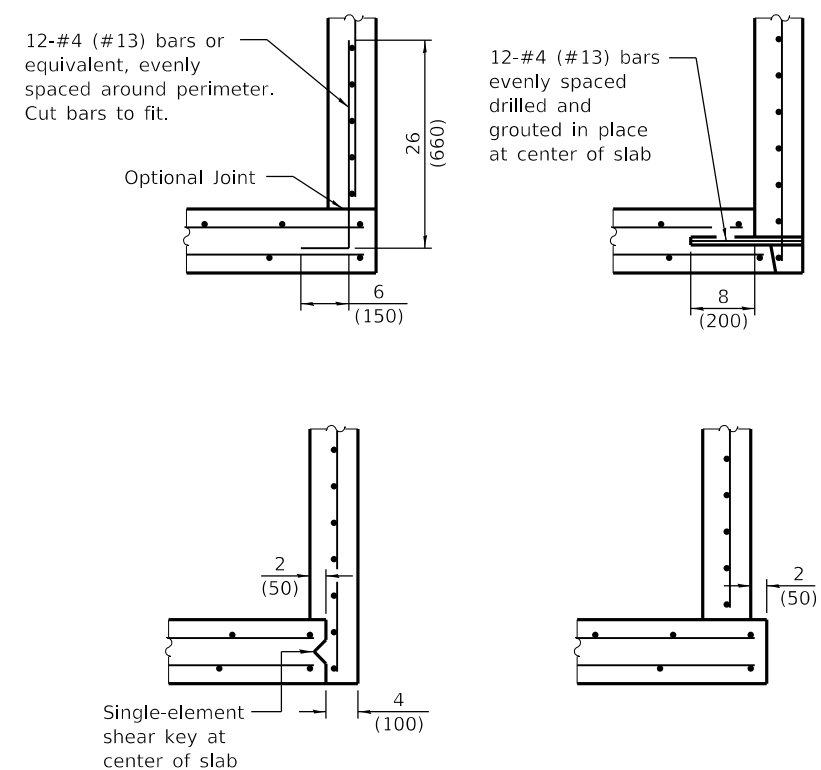

BASE SLAB JOINT CONFIGURATIONS

GENERAL NOTES

- The manufacturer shall ensure that all precast manhole sections are additionally reinforced where required to resist damage from handling, shipping and installation stresses.
- Lifting holes shall be located in the sections as per the manufacturer's recommendations.
- See Standard 602701 for details of manhole steps.
- All dimensions are in inches (millimeters) unless otherwise noted.

DATE	REVISIONS
1-1-21	Revised Note 1 and lifting hole general note.
3-1-19	Moved wall reinforcement from inside face to middle.

PRECAST MANHOLE TYPE A
5' (1.52 m) DIAMETER

(Sheet 1 of 2)

STANDARD 602402-03

Illinois Department of Transportation

PASSED January 1, 2021

 ENGINEER OF POLICY AND PROCEDURES

APPROVED January 1, 2021

 ENGINEER OF DESIGN AND ENVIRONMENT

ISSUES
 81-1-1 QMS/SL

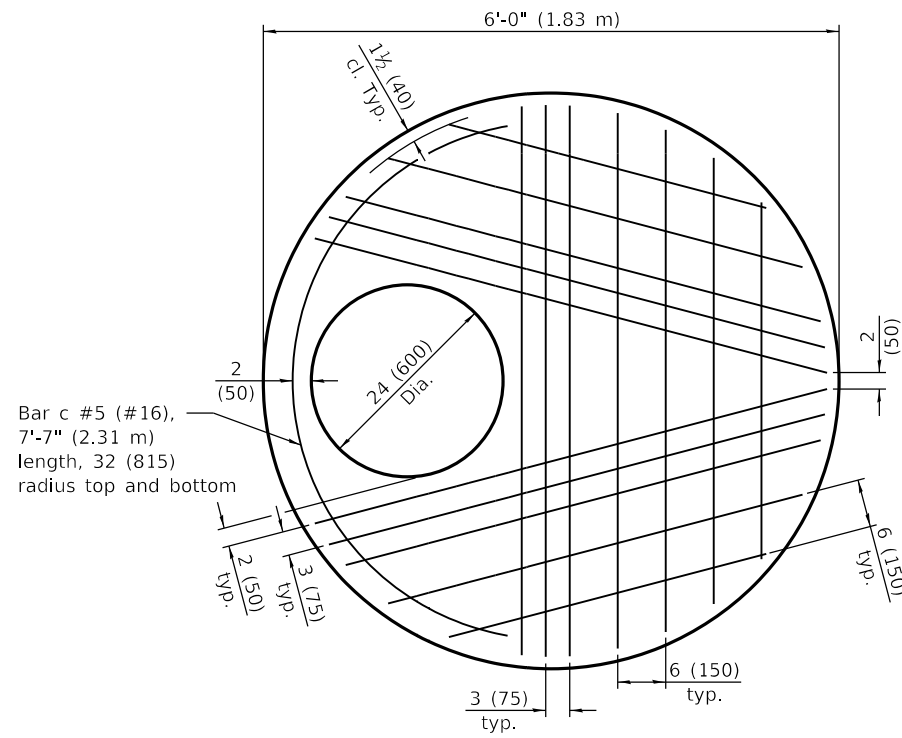

PLAN - FLAT SLAB TOP

(Showing layout of bottom reinforcement bars and c bars)

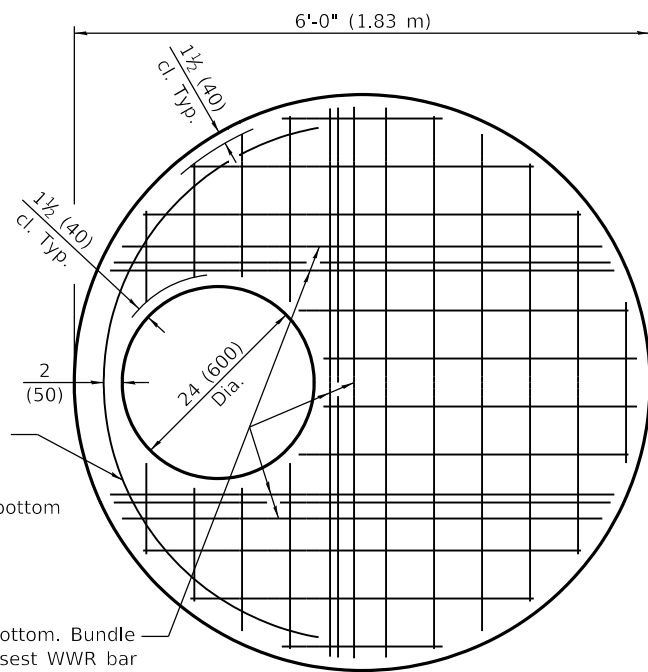

PLAN - FLAT SLAB TOP

(Showing layout of welded wire reinforcement and c bars)

1(25) \varnothing Threaded rods with $2\frac{1}{4} \times 2\frac{1}{4} \times \frac{5}{16}$ (55x55x8) \varnothing washers under each nut. All nuts shall be brought to a snug tight condition. Holes in the walls may be drilled using core bits in lieu of formed holes.

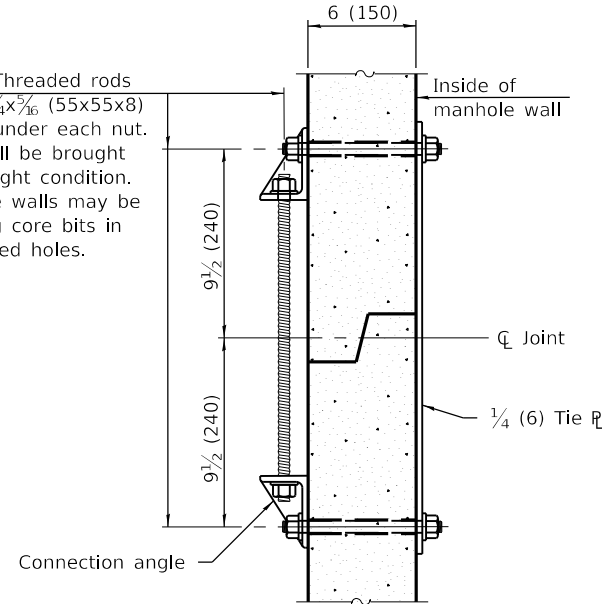

JOINT SPLICE

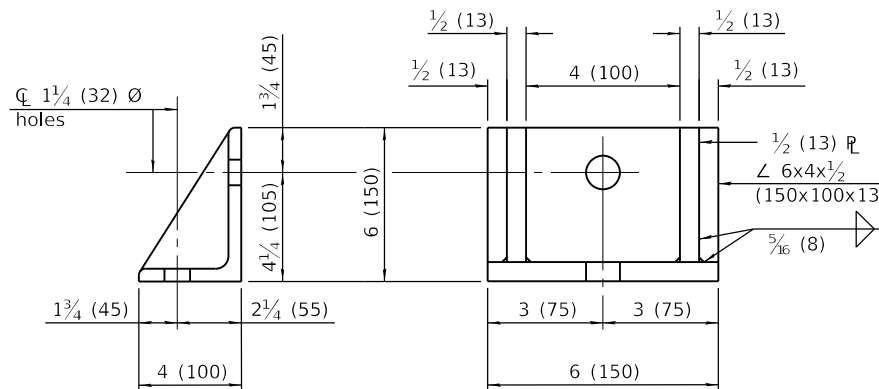

CONNECTION ANGLE

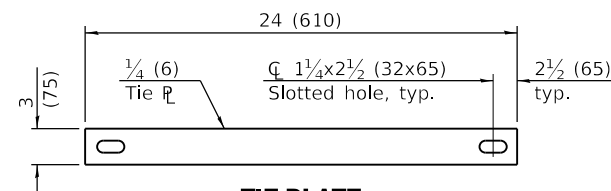

TIE PLATE

FLAT SLAB TOP REINFORCEMENT

Location	WWR (each direction)		Rebar (each direction except as noted)		
	A _s (min.)	Spacing (max.)	A _s (min.)	Spacing (max.)	Bar Size
Top Mat	0.11 sq. in./ft. (233 sq. mm/m)	18 (450)	0.11 sq. in./ft. (233 sq. mm/m)	18 (450)	#3 or #4 (#10) (#13)
Bottom Mat	** 0.40 sq. in./ft. (847 sq. mm/m)	6 (150)	See plan view for rebar orientation and spacing and this table for bar size		#4 (#13)

** Only one layer of WWR permitted to avoid congestion.

WALL REINFORCEMENT

Location	Orientation	WWR or Rebar	
		A _s (min.)	Spacing (max.)
Riser	Circumferential	0.15 sq. in./ft. (318 sq. mm/m)	6 (150)
	Vertical	0.045 sq. in./ft. (95 sq. mm/m)	8 (200)
Barrel	Circumferential	0.15 sq. in./ft. (318 sq. mm/m)	6 (150)
	Vertical	0.16 sq. in./ft. (339 sq. mm/m)	4 (100)

BASE SLAB REINFORCEMENT

Location	Total Height	WWR or Rebar (each direction)	
		A _s (min.)	Spacing (max.)
Top Mat	≤ 20 ft. (6.10 m)	0.24 sq. in./ft. (508 sq. mm/m)	10 (250)
	> 20 ft. (6.10 m)	0.28 sq. in./ft. (593 sq. mm/m)	8 (200)
Bottom Mat	All	0.11 sq. in./ft. (233 sq. mm/m)	18 (450)

Illinois Department of Transportation

PASSED January 1, 2021

ENGINEER OF POLICY AND PROCEDURES

APPROVED January 1, 2021

ENGINEER OF DESIGN AND ENVIRONMENT

ISSUED 1-1-18

PRECAST MANHOLE TYPE A
5' (1.52 m) DIAMETER

(Sheet 2 of 2)

STANDARD 602402-03

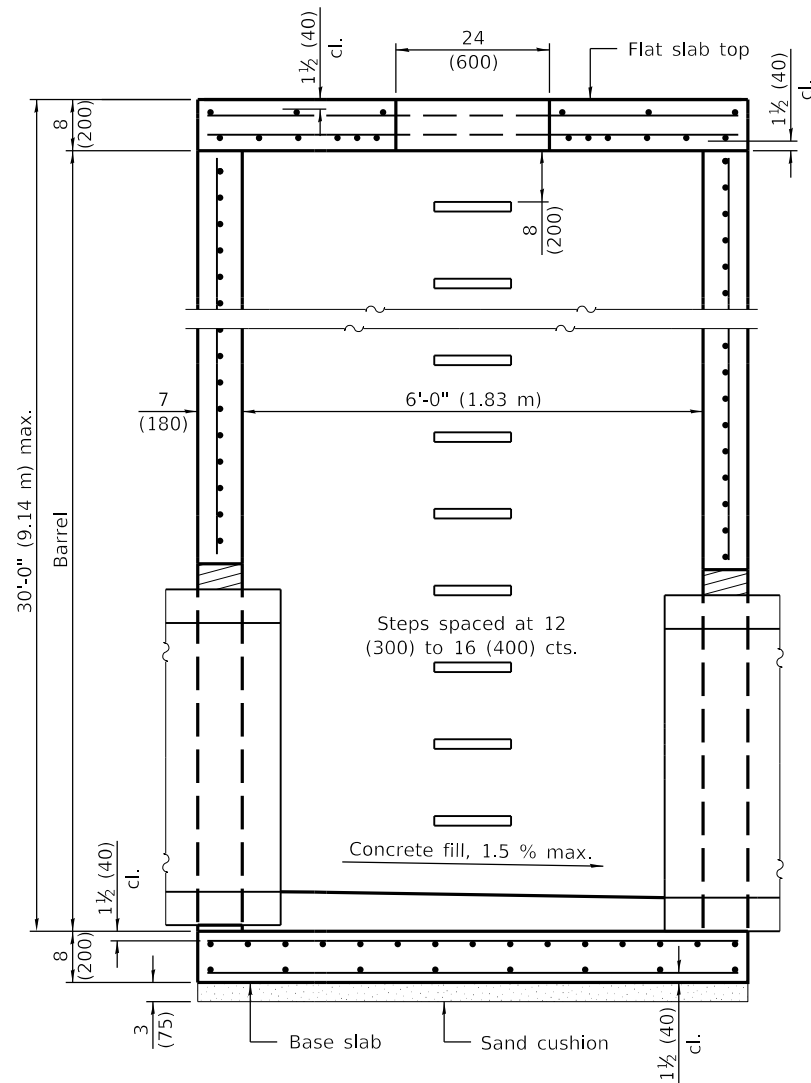

SECTION PARALLEL TO PIPE
(Without conical top riser)

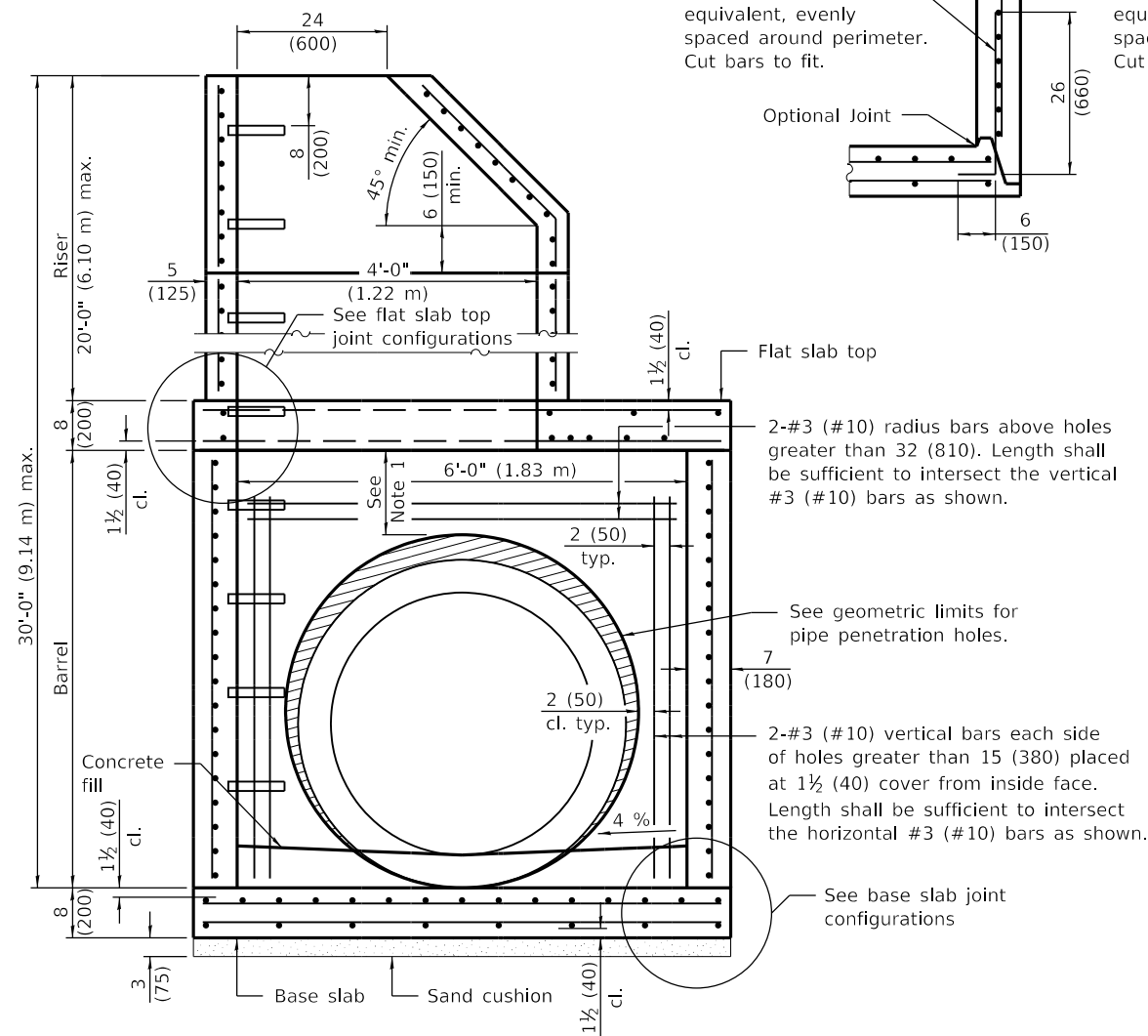

SECTION PERPENDICULAR TO PIPE
(With conical top riser)

11-#4 (#13) bars or equivalent, evenly spaced around perimeter. Cut bars to fit.

11-#4 (#13) bars or equivalent, evenly spaced around perimeter. Cut bars to fit.

14-#5 (#16) bars evenly spaced drilled and grouted in place at center of slab

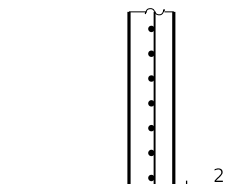
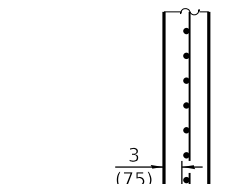
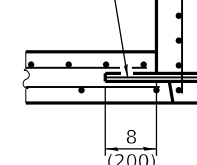
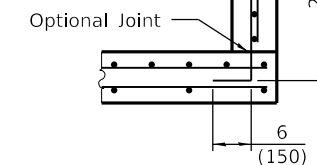
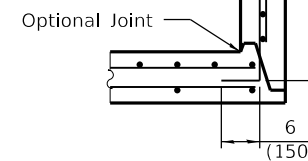

Single-element shear key at center of slab

BASE SLAB JOINT CONFIGURATIONS

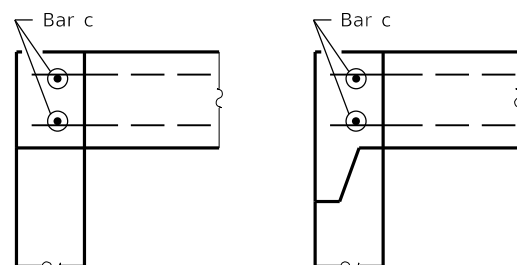

FLAT SLAB TOP JOINT CONFIGURATIONS
(Shown at access hole)

GEOMETRIC LIMITS FOR PIPE PENETRATION HOLES

- Note 1: A minimum of 9 (230) of monolithic reinforced concrete shall be maintained above pipe penetration holes > 32 (810).
- Note 2: A minimum 12 (300) inside arc length of reinforced concrete shall be maintained between pipe penetration holes > 15 (380).
- Note 3: A maximum of 60 percent of the inside perimeter of the reinforced concrete manhole walls may be removed.
- Note 4: Horizontal joints that intersect pipe penetration holes > 15 (380) shall have one joint splice for every location around the perimeter of the joint where the inside arc length between pipe penetration holes is < 24 (600). See joint splice detail.
- Note 5: The recommended pipe penetration hole is equal to the O.D. of the pipe plus 4 (100).
- Note 6: Only pipe penetration holes ≤ 15 (380) are allowed in riser sections.

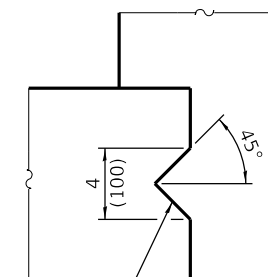

Single-element shear key at center of slab

SHEAR KEY GEOMETRY
(Reinforcement not shown for clarity)

GENERAL NOTES

- Pipe holes shall be formed to facilitate proper placement of hole reinforcement.
- The manufacturer shall ensure that all precast manhole sections are additionally reinforced where required to resist damage from handling, shipping and installation stresses.
- Lifting holes shall be located in the sections as per the manufacturer's recommendations.
- See Standard 602701 for details of manhole steps.
- All dimensions are in inches (millimeters) unless otherwise noted.

DATE	REVISIONS
1-1-21	Revised Note 1, Note 2 and lifting hole general note.
3-1-19	Moved wall reinforcement from inside face to middle.

PRECAST MANHOLE TYPE A
6' (1.83 m) DIAMETER
(Sheet 1 of 3)

STANDARD 602406-11

Illinois Department of Transportation

PASSED January 1, 2021
Michael Bond
ENGINEER OF POLICY AND PROCEDURES

APPROVED January 1, 2021
J. E. C.
ENGINEER OF DESIGN AND ENVIRONMENT

ISSUED 1-1-21
46-1

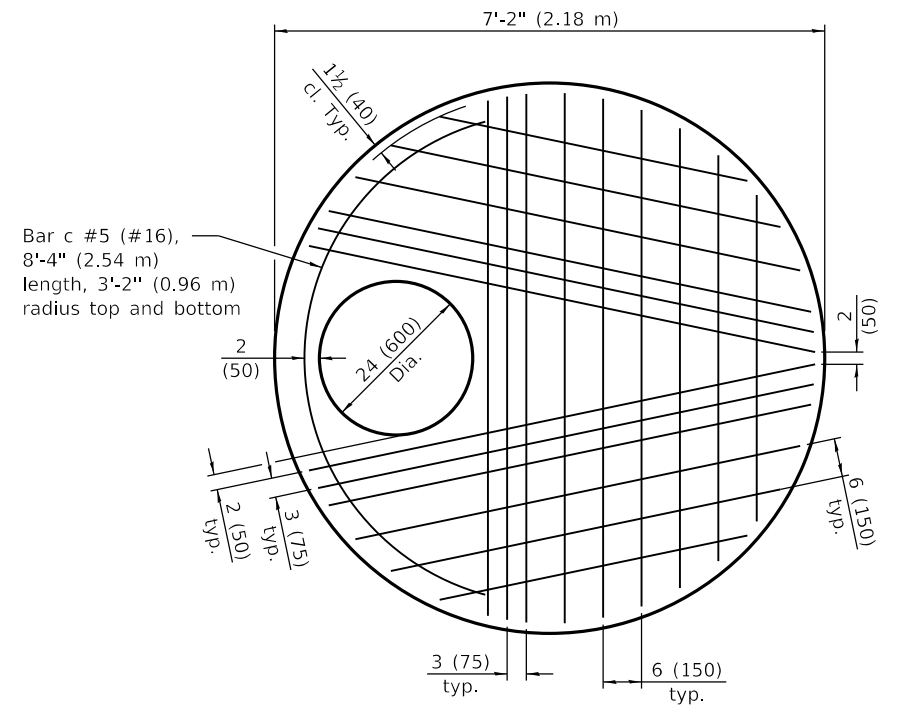
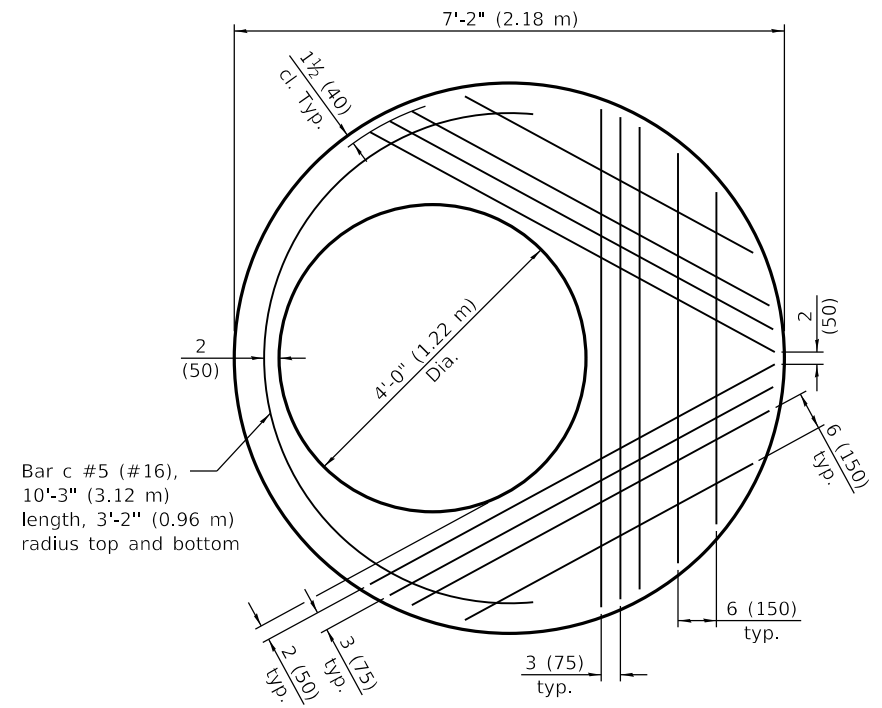

PLAN - FLAT SLAB TOP

(Showing layout of bottom reinforcement bars and c bars)

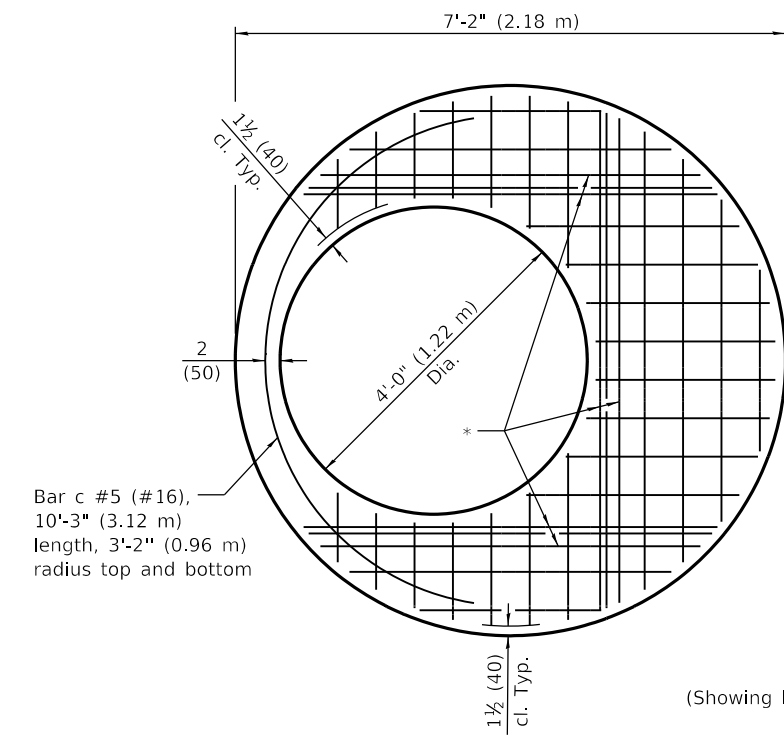

PLAN - FLAT SLAB TOP

(Showing layout of welded wire reinforcement and c bars)

Bar c #5 (#16),
8'-4" (2.54 m)
length, 3'-2" (0.96 m)
radius top and bottom

Bar c #5 (#16),
8'-4" (2.54 m)
length, 3'-2" (0.96 m)
radius top and bottom

* #5 (#16) bars for risers ≤ 10 ft. (3.05 m) tall or #6 (#19) bars for risers > 10 ft. (3.05 m) tall bottom. Bundle first bar with closest WWR bar to the opening and place second bar ±3 (75) away.

Illinois Department of Transportation

PASSED January 1, 2021

 ENGINEER OF POLICY AND PROCEDURES

APPROVED January 1, 2021

 ENGINEER OF DESIGN AND ENVIRONMENT

ISSUED 1-1-97

PRECAST MANHOLE TYPE A
6' (1.83 m) DIAMETER
 (Sheet 2 of 3)

STANDARD 602406-11

\varnothing 1(25) \varnothing Threaded rods with $2\frac{1}{4} \times 2\frac{1}{4} \times \frac{3}{16}$ (55x55x8) \varnothing washers under each nut. All nuts shall be brought to a snug tight condition. Holes in the walls may be drilled using core bits in lieu of formed holes.

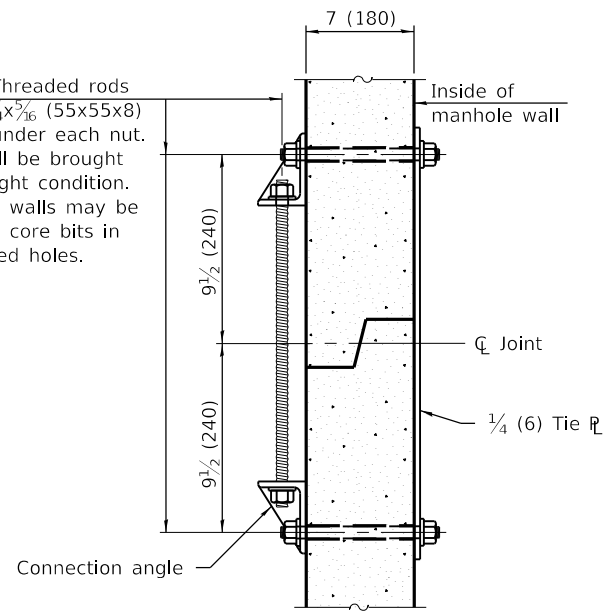

JOINT SPLICE

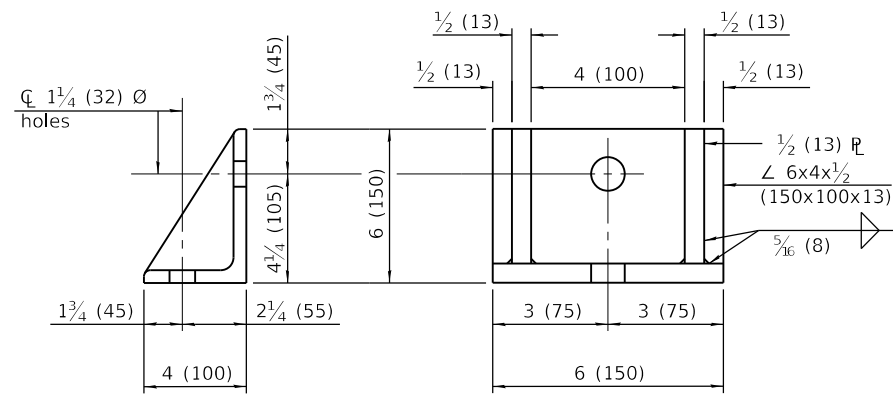

CONNECTION ANGLE

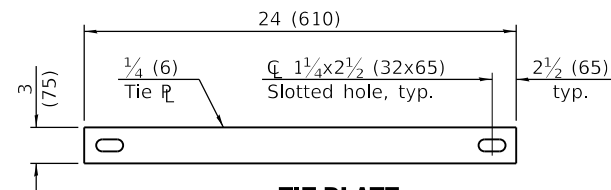

TIE PLATE

FLAT SLAB TOP REINFORCEMENT

Location	Riser Height (RH)	WWR (each direction)		Rebar (each direction except as noted)		
		A_s (min.)	Spacing (max.)	A_s (min.)	Spacing (max.)	Bar Size
Top Mat	All	0.11 sq. in./ft. (233 sq. mm/m)	18 (450)	0.11 sq. in./ft. (233 sq. mm/m)	18 (450)	#3 or #4 (#10) (#13)
Bottom Mat	RH \leq 10 ft. (3.05 m)	** 0.62 sq. in./ft. (1312 sq. mm/m)	6 (150)	See plan view for rebar orientation and spacing and this table for bar size		#5 (#16)
	RH > 10 ft. (3.05 m)	** 0.88 sq. in./ft. (1863 sq. mm/m)	6 (150)			#6 (#19)

** Only one layer of WWR permitted to avoid congestion.

WALL REINFORCEMENT

Location	Orientation	WWR or Rebar	
		A_s (min.)	Spacing (max.)
4 ft. (1.22 m) \varnothing Riser	Circumferential	0.12 sq. in./ft. (254 sq. mm/m)	6 (150)
	Vertical	0.045 sq. in./ft. (95 sq. mm/m)	8 (200)
6 ft. (1.83 m) \varnothing Barrel	Circumferential	0.18 sq. in./ft. (381 sq. mm/m)	6 (150)
	Vertical	0.045 sq. in./ft. (95 sq. mm/m)	8 (200)

BASE SLAB REINFORCEMENT

Location	Riser Height (RH)/ Total Height (TH)	WWR or Rebar (each direction)	
		A_s (min.)	Spacing (max.)
Top Mat	RH \leq 10 ft. (3.05 m) & TH \leq 20 ft. (6.10 m)	0.28 sq. in./ft. (593 sq. mm/m)	6 (150)
	RH > 10 ft. (3.05 m) or TH > 20 ft. (6.10 m)	0.40 sq. in./ft. (847 sq. mm/m)	6 (150)
Bottom Mat	All	0.11 sq. in./ft. (233 sq. mm/m)	18 (450)

Illinois Department of Transportation
 PASSED January 1, 2021
 ENGINEER OF POLICY AND PROCEDURES
 APPROVED January 1, 2021
 ENGINEER OF DESIGN AND ENVIRONMENT

ISSUED 1-1-97

**PRECAST MANHOLE TYPE A
6' (1.83 m) DIAMETER**

(Sheet 3 of 3)

STANDARD 602406-11

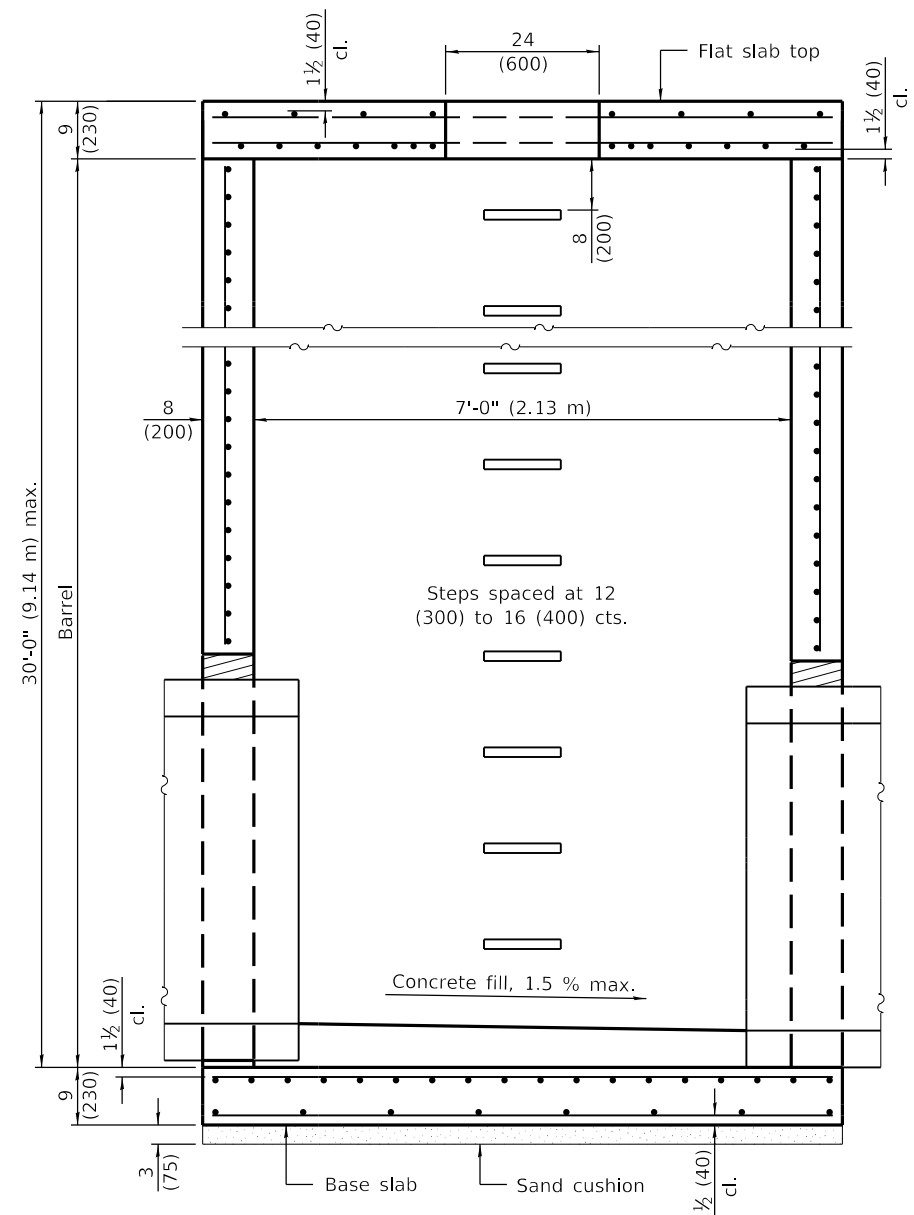

SECTION PARALLEL TO PIPE
(Without conical top riser)

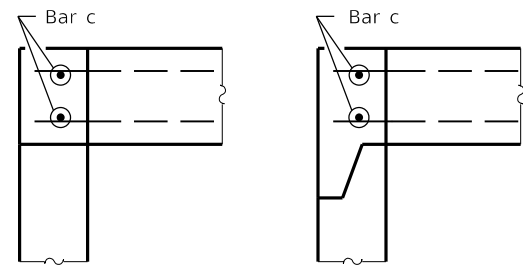

FLAT SLAB TOP JOINT CONFIGURATIONS
(Shown at access hole)

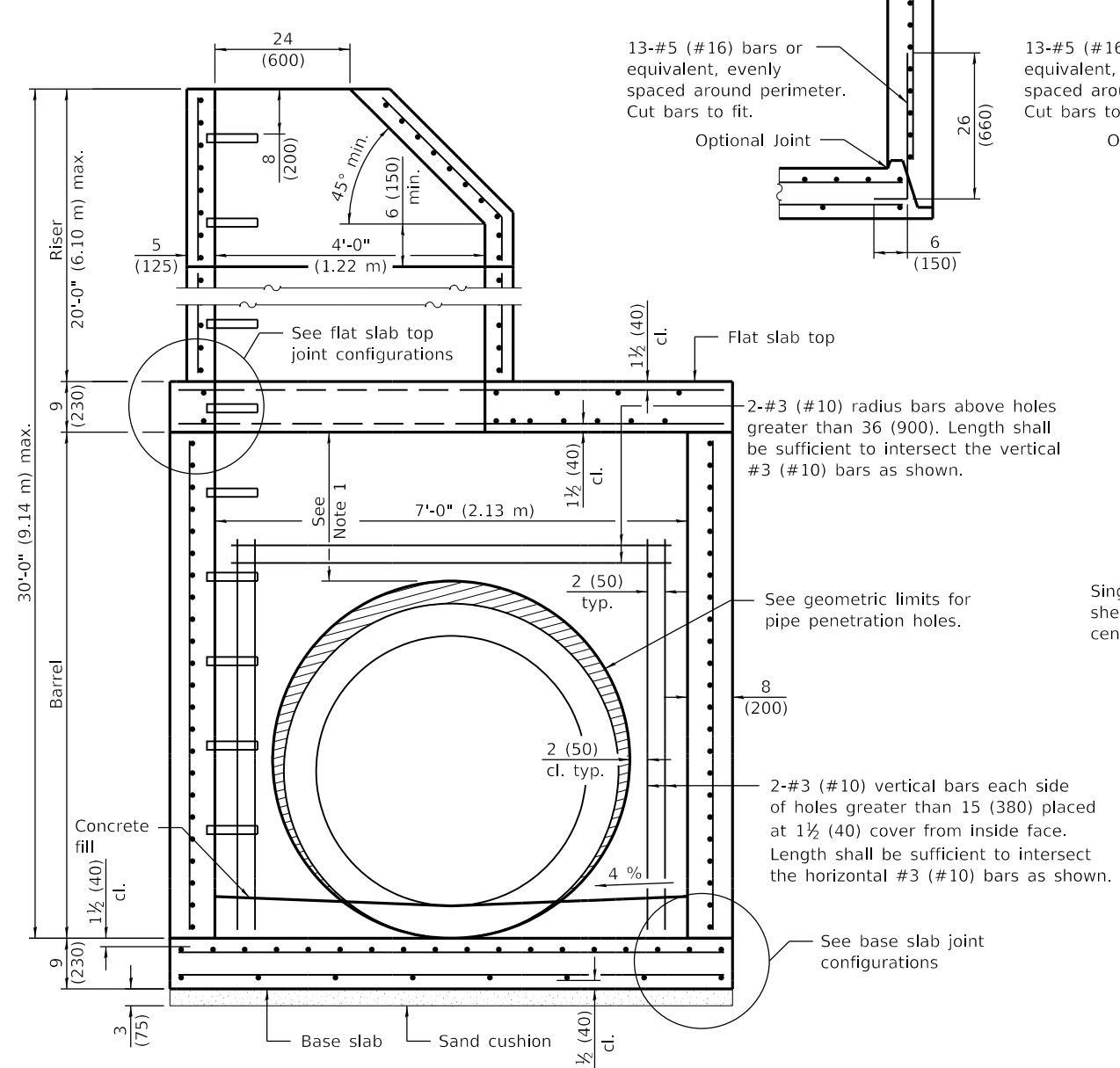

SECTION PERPENDICULAR TO PIPE
(With conical top riser)

GEOMETRIC LIMITS FOR PIPE PENETRATION HOLES

- Note 1: A minimum of 12 (300) of monolithic reinforced concrete shall be maintained above pipe penetration holes > 36 (900).
- Note 2: A minimum 12 (300) inside arc length of reinforced concrete shall be maintained between pipe penetration holes > 15 (380).
- Note 3: A maximum of 60 percent of the inside perimeter of the reinforced concrete manhole walls may be removed.
- Note 4: Horizontal joints that intersect pipe penetration holes > 15 (380) shall have one joint splice for every location around the perimeter of the joint where the inside arc length between pipe penetration holes is < 24 (600). See joint splice detail.
- Note 5: The recommended pipe penetration hole is equal to the O.D. of the pipe plus 4 (100).
- Note 6: Only pipe penetration holes ≤ 15 (380) are allowed in riser sections.

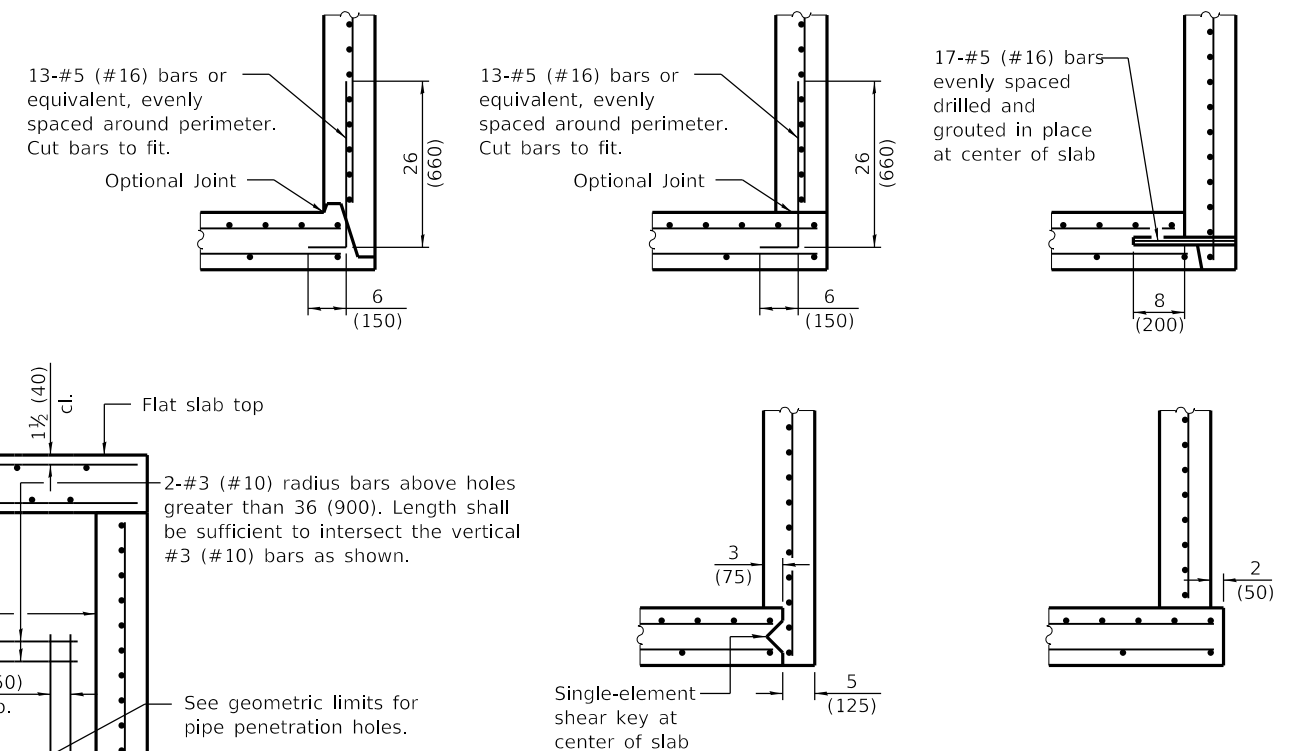

BASE SLAB JOINT CONFIGURATIONS

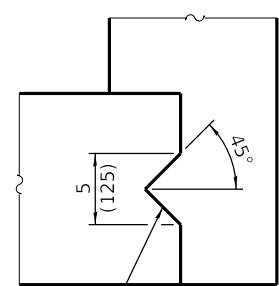

SHEAR KEY GEOMETRY
(Reinforcement not shown for clarity)

GENERAL NOTES

- Pipe holes shall be formed to facilitate proper placement of hole reinforcement.
- The manufacturer shall ensure that all precast manhole sections are additionally reinforced where required to resist damage from handling, shipping and installation stresses.
- Lifting holes shall be located in the sections as per the manufacturer's recommendations.
- See Standard 602701 for details of manhole steps.
- All dimensions are in inches (millimeters) unless otherwise noted.

Illinois Department of Transportation

PASSED January 1, 2021

 ENGINEER OF POLICY AND PROCEDURES

APPROVED January 1, 2021

 ENGINEER OF DESIGN AND ENVIRONMENT

ISSUED 4-1-06

DATE	REVISIONS
1-1-21	Revised Note 1 and lifting hole general note.
3-1-19	Moved wall reinforcement from inside face to middle.

PRECAST MANHOLE TYPE A
7' (2.13 m) DIAMETER
 (Sheet 1 of 3)

STANDARD 602411-09

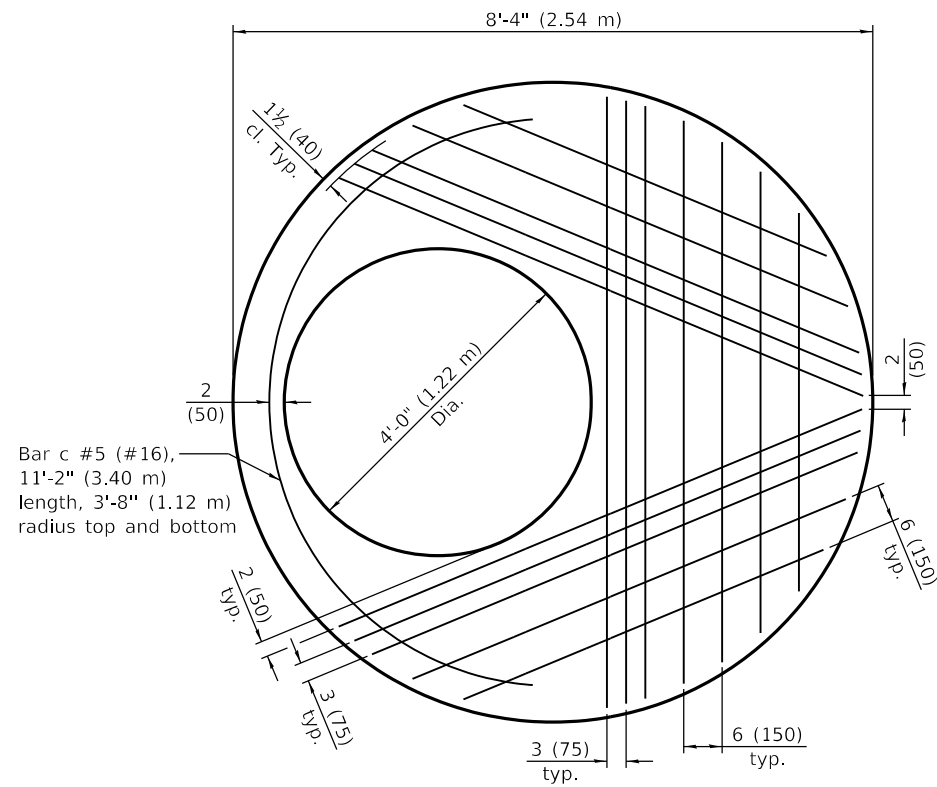

PLAN - FLAT SLAB TOP

(Showing layout of bottom reinforcement bars and c bars)

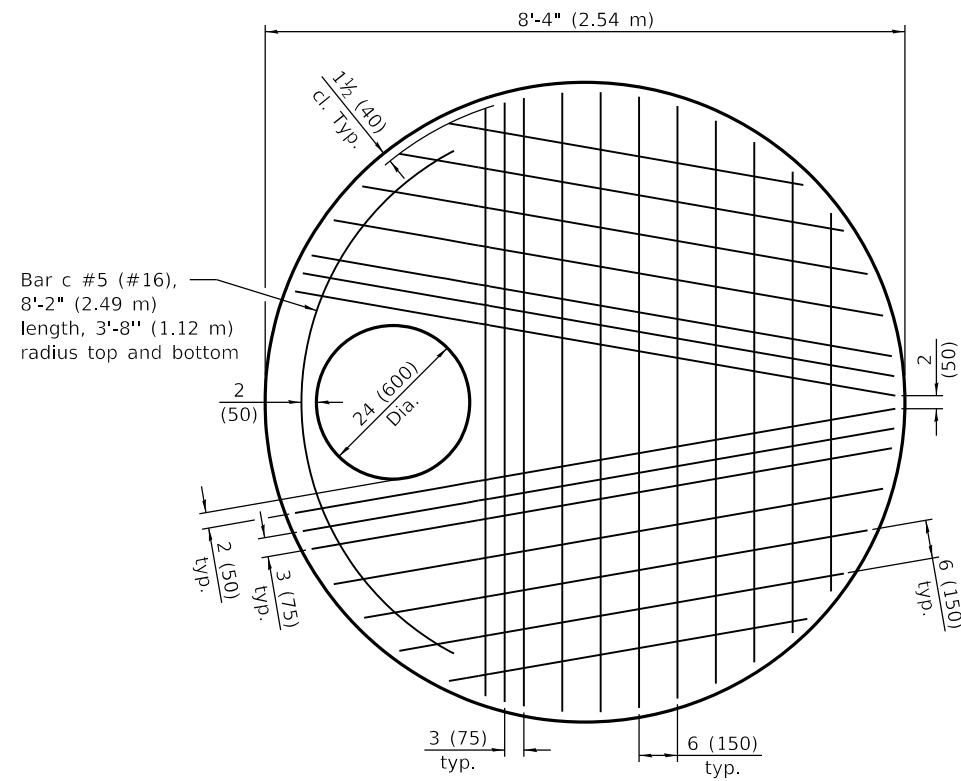

PLAN - FLAT SLAB TOP

(Showing layout of Welded Wire Reinforcement and c bars)
WWR not permitted for riser heights > 10' (3.05 m).

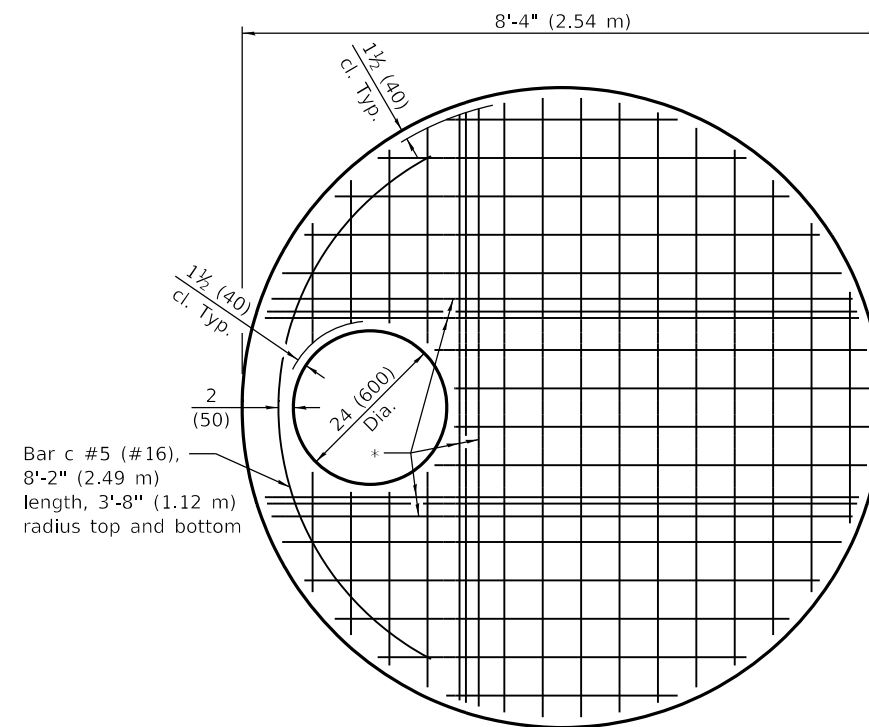
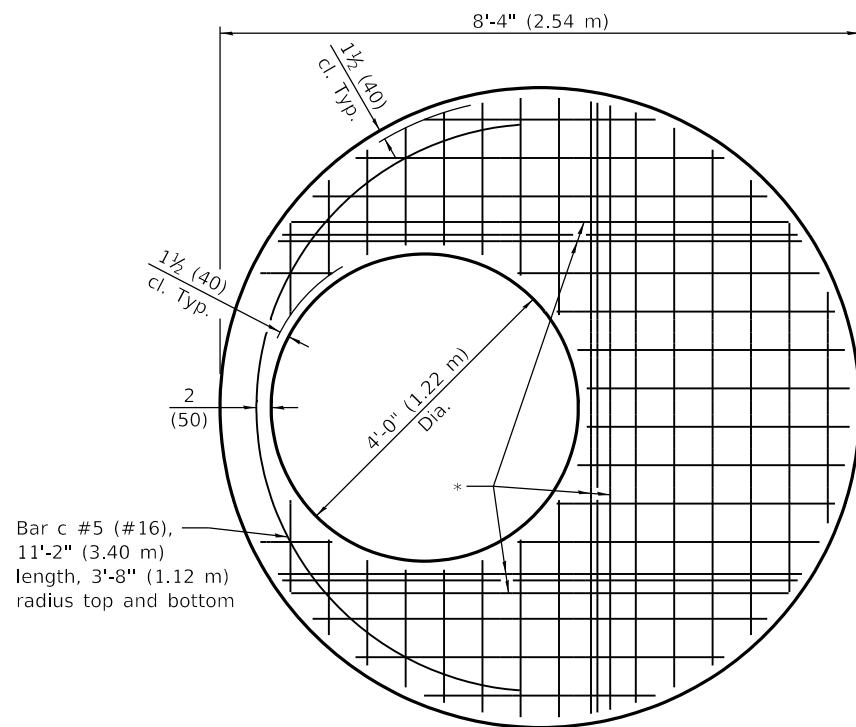

* #5 (#16) bars bottom. Bundle first bar with closest WWR bar to the opening and place second bar ±3 (75) away.

PRECAST MANHOLE TYPE A
7' (2.13 m) DIAMETER

(Sheet 2 of 3)

STANDARD 602411-09

Illinois Department of Transportation

PASSED January 1, 2021
Michael Bond
ENGINEER OF POLICY AND PROCEDURES

ISSUED 4-1-06

APPROVED January 1, 2021
J. E. C.
ENGINEER OF DESIGN AND ENVIRONMENT

1(25) \varnothing Threaded rods with $2\frac{1}{4} \times 2\frac{1}{4} \times \frac{5}{16}$ (55x55x8) \varnothing washers under each nut. All nuts shall be brought to a snug tight condition. Holes in the walls may be drilled using core bits in lieu of formed holes.

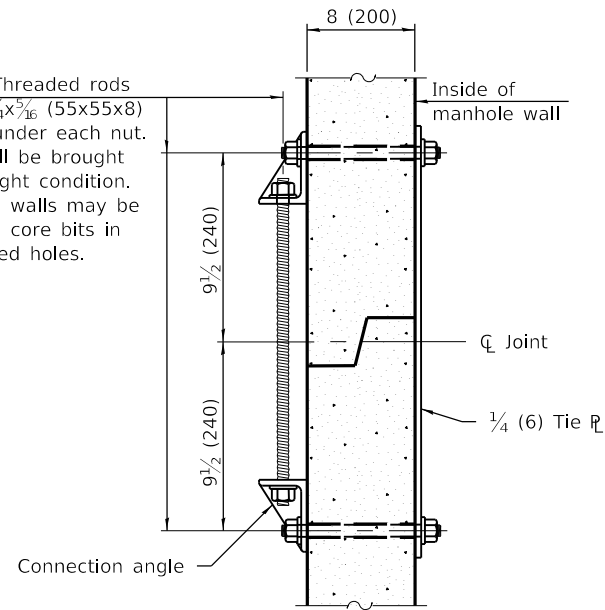

JOINT SPLICE

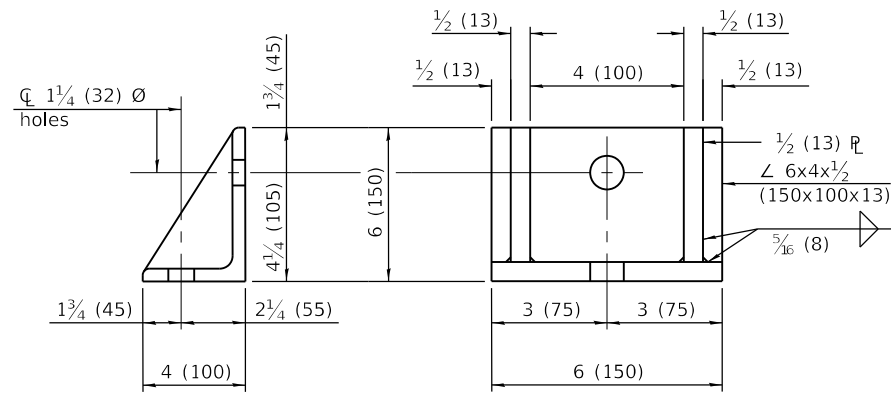

CONNECTION ANGLE

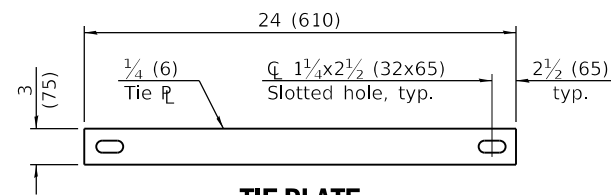

TIE PLATE

FLAT SLAB TOP REINFORCEMENT

Location	Riser Height (RH)	WWR (each direction)		Rebar (each direction except as noted)		
		A _s (min.)	Spacing (max.)	A _s (min.)	Spacing (max.)	Bar Size
Top Mat	All	0.11 sq. in./ft. (233 sq. mm/m)	18 (450)	0.11 sq. in./ft. (233 sq. mm/m)	18 (450)	#3 or #4 (#10) (#13)
Bottom Mat	RH ≤ 10 ft. (3.05 m)	** 0.62 sq. in./ft. (312 sq. mm/m)	6 (150)	See plan view for rebar orientation and spacing and this table for bar size		#5 (#16)
	RH > 10 ft. (3.05 m)	WWR not permitted				#7 (#22)

** Only one layer of WWR permitted to avoid congestion.

WALL REINFORCEMENT

Location	Orientation	WWR or Rebar	
		A _s (min.)	Spacing (max.)
4 ft. (1.22 m) \varnothing Riser	Circumferential	0.12 sq. in./ft. (254 sq. mm/m)	6 (150)
	Vertical	0.045 sq. in./ft. (95 sq. mm/m)	8 (200)
7 ft. (2.13 m) \varnothing Barrel	Circumferential	0.21 sq. in./ft. (445 sq. mm/m)	6 (150)
	Vertical	0.045 sq. in./ft. (95 sq. mm/m)	8 (200)

BASE SLAB REINFORCEMENT

Location	Riser Height (RH)/ Total Height (TH)	WWR or Rebar (each direction)	
		A _s (min.)	Spacing (max.)
Top Mat	RH ≤ 10 ft. (3.05 m) & TH ≤ 20 ft. (6.10 m)	0.32 sq. in./ft. (677 sq. mm/m)	6 (150)
	RH > 10 ft. (3.05 m) or TH > 20 ft. (6.10 m)	0.52 sq. in./ft. (1101 sq. mm/m)	6 (150)
Bottom Mat	All	0.11 sq. in./ft. (233 sq. mm/m)	18 (450)

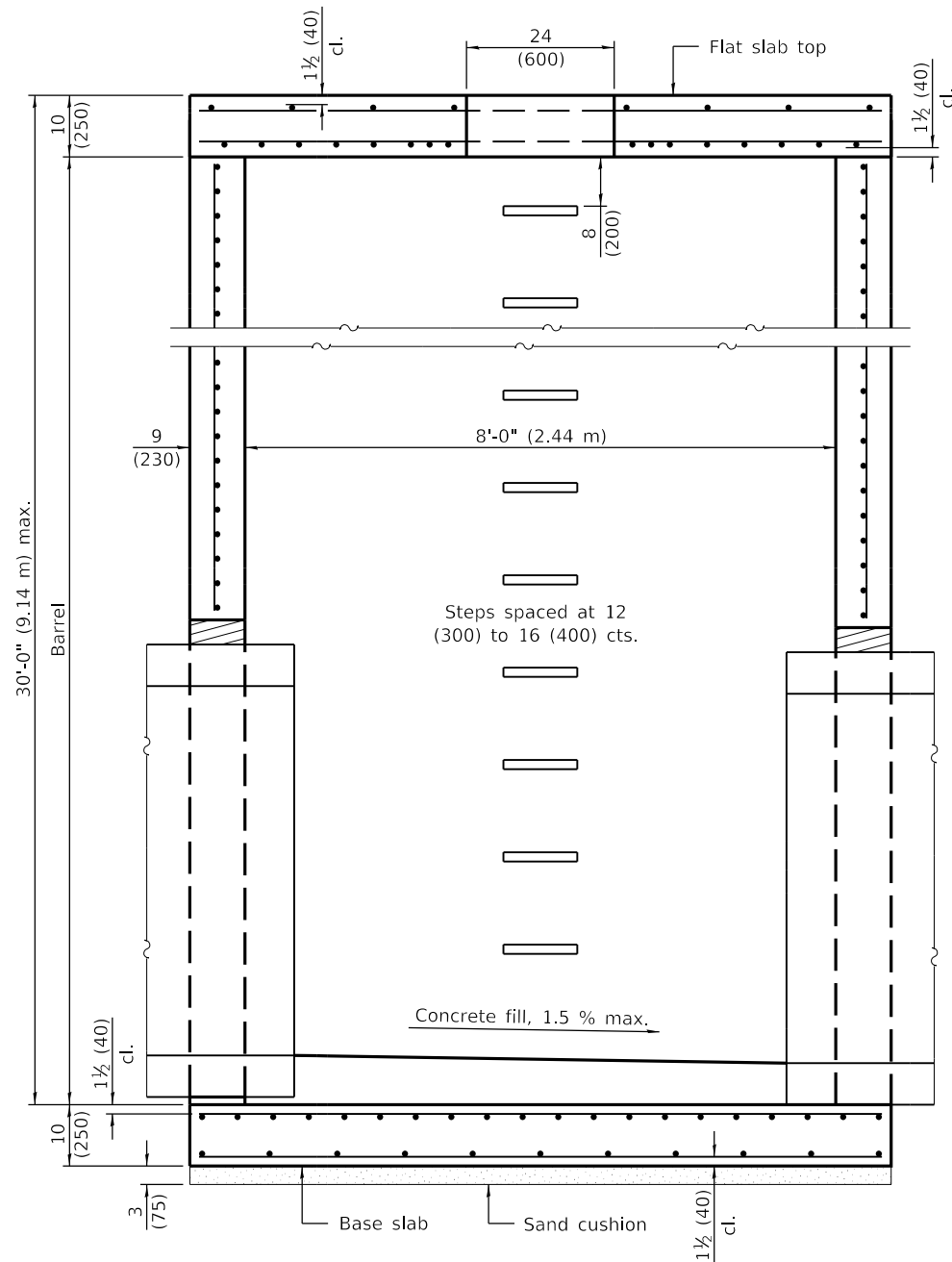

SECTION PARALLEL TO PIPE
(Without conical top riser)

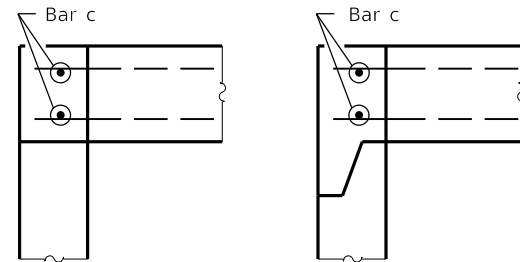

FLAT SLAB TOP JOINT CONFIGURATIONS
(Shown at access hole)

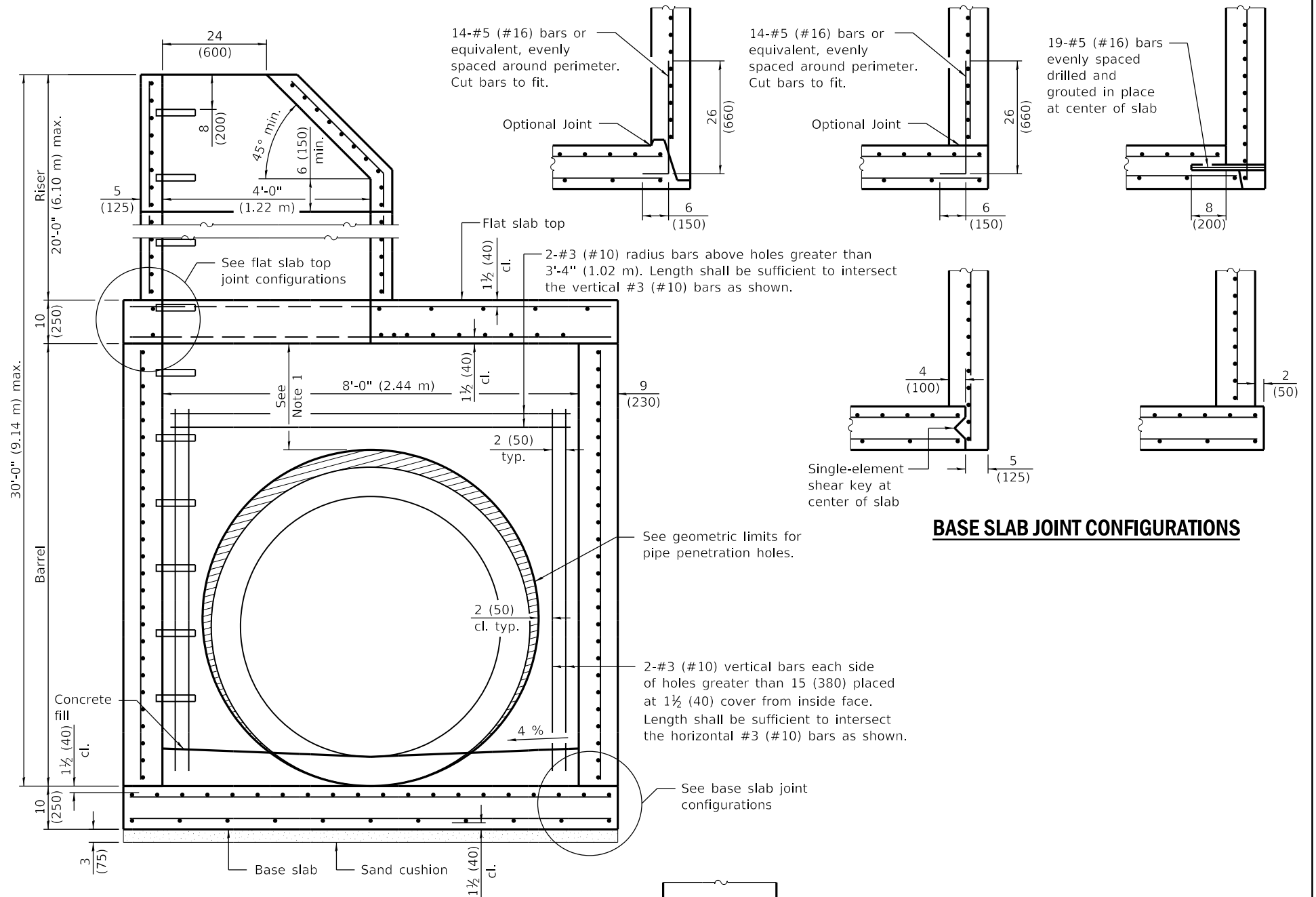

SECTION PERPENDICULAR TO PIPE
(With conical top riser)

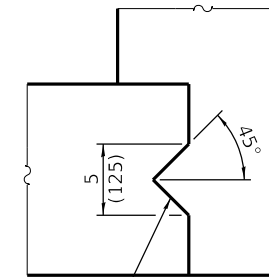

Single-element shear key at center of slab

SHEAR KEY GEOMETRY
(Reinforcement not shown for clarity)

BASE SLAB JOINT CONFIGURATIONS

GEOMETRIC LIMITS FOR PIPE PENETRATION HOLES

- Note 1: A minimum of 12 (300) of monolithic reinforced concrete shall be maintained above pipe penetration holes > 3'-4" (1.02 m).
- Note 2: A minimum 12 (300) inside arc length of reinforced concrete shall be maintained between pipe penetration holes > 15 (380).
- Note 3: A maximum of 60 percent of the inside perimeter of the reinforced concrete manhole walls may be removed.
- Note 4: Horizontal joints that intersect pipe penetration holes > 15 (380) shall have one joint splice for every location around the perimeter of the joint where the inside arc length between pipe penetration holes is < 24 (600). See joint splice detail.
- Note 5: The recommended pipe penetration hole is equal to the O.D. of the pipe plus 4 (100).
- Note 6: Only pipe penetration holes ≤ 15 (380) are allowed in riser sections.

GENERAL NOTES

- Pipe holes shall be formed to facilitate proper placement of hole reinforcement.
- The manufacturer shall ensure that all precast manhole sections are additionally reinforced where required to resist damage from handling, shipping and installation stresses.
- Lifting holes shall be located in the sections as per the manufacturer's recommendations.
- See Standard 602701 for details of manhole steps.
- All dimensions are in inches (millimeters) unless otherwise noted.

DATE	REVISIONS
1-1-21	Revised Note 1 and lifting hole general note.
3-1-19	Moved wall reinforcement from inside face to middle.

PRECAST MANHOLE TYPE A
8' (2.44 m) DIAMETER
(Sheet 1 of 3)

STANDARD 602416-09

Illinois Department of Transportation

PASSED January 1, 2021
Michael Bond
ENGINEER OF POLICY AND PROCEDURES

APPROVED January 1, 2021
J. E. ...
ENGINEER OF DESIGN AND ENVIRONMENT

ISSUED 4-1-06

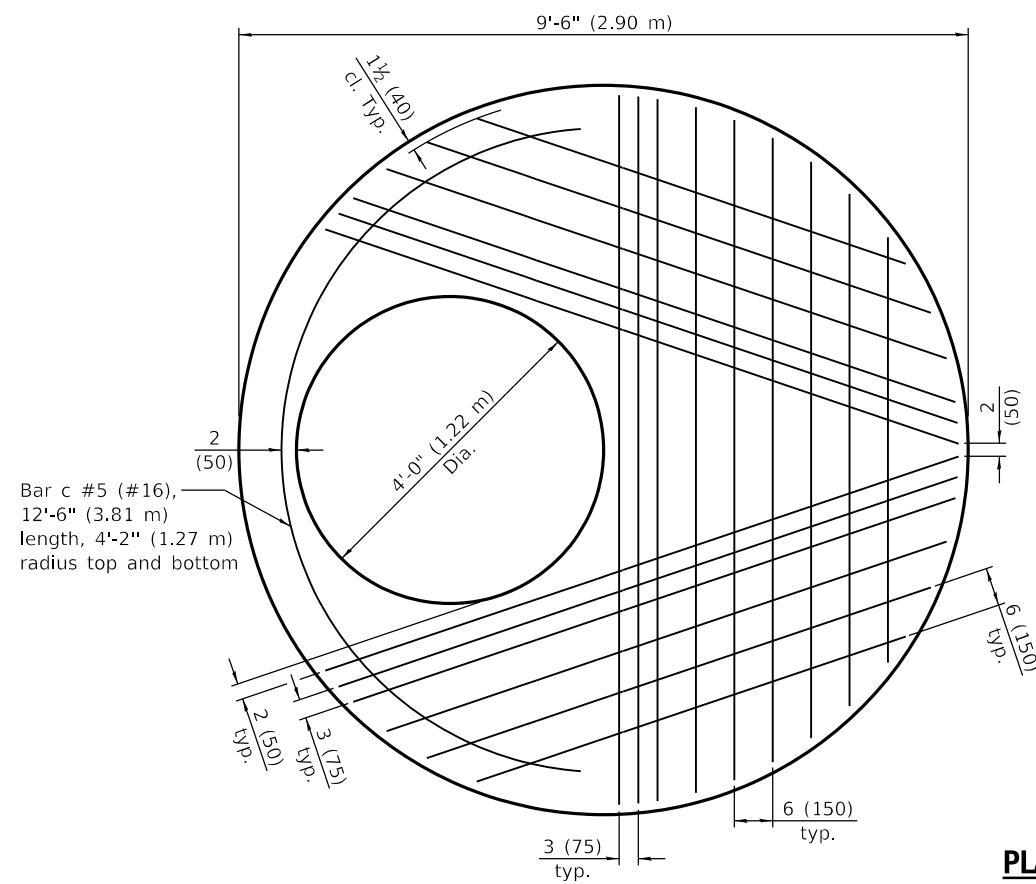

PLAN - FLAT SLAB TOP

(Showing layout of bottom reinforcement bars and c bars)

Bar c #5 (#16),
9'-2" (2.79 m)
length, 4'-2" (1.27 m)
radius top and bottom

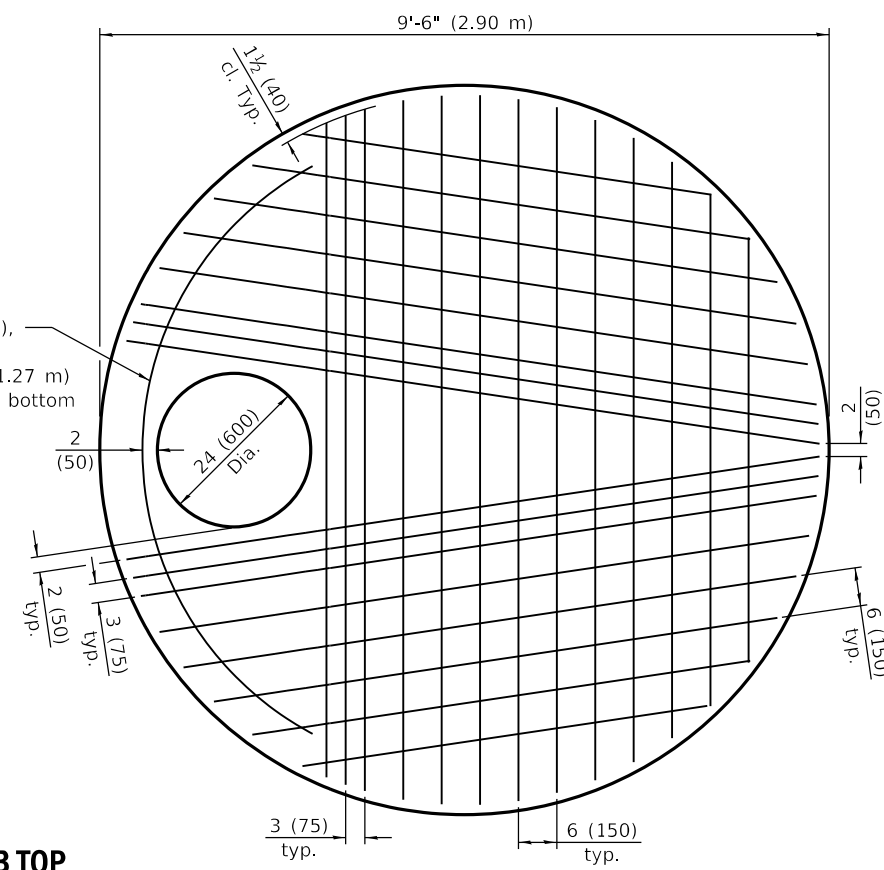

PLAN - FLAT SLAB TOP

(Showing layout of Welded Wire Reinforcement and c bars)
WWR not permitted for riser heights > 10' (3.05 m).

Bar c #5 (#16),
9'-2" (2.79 m)
length, 4'-2" (1.27 m)
radius top and bottom

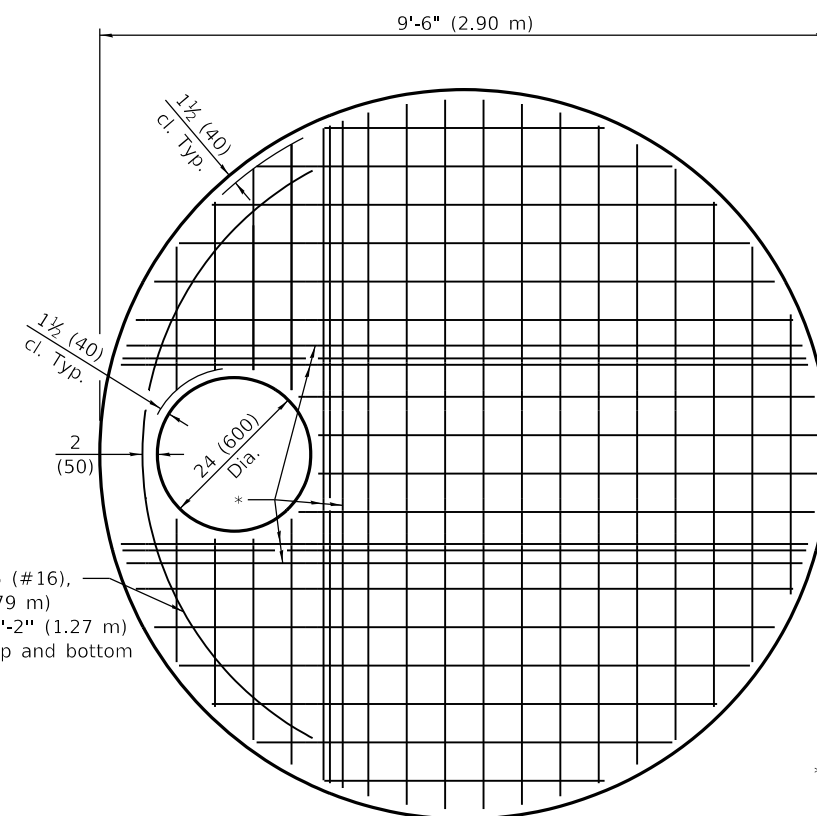
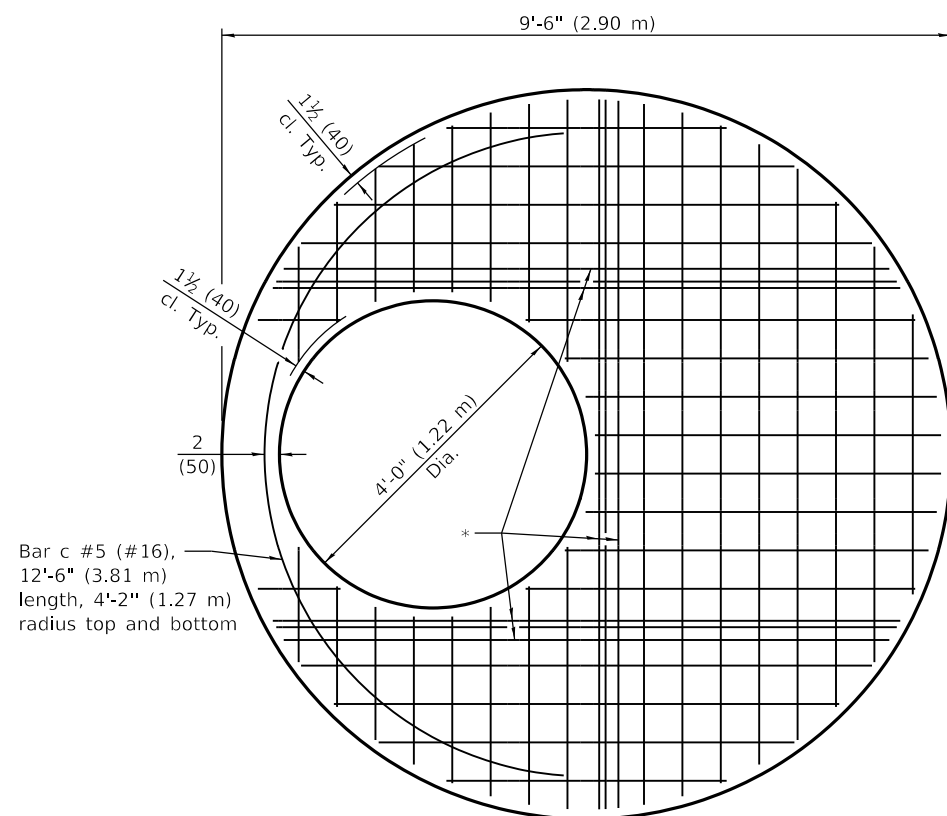

* #6 (#19) bars bottom. Bundle first bar with closest WWR bar to the opening and place second bar ±3 (75) away.

PRECAST MANHOLE TYPE A
8' (2.44 m) DIAMETER

(Sheet 2 of 3)

STANDARD 602416-09

Illinois Department of Transportation

PASSED January 1, 2021
Michael Bond
ENGINEER OF POLICY AND PROCEDURES

APPROVED January 1, 2021
J. E. C. G.
ENGINEER OF DESIGN AND ENVIRONMENT

ISSUED 4-1-06

\varnothing 1(25) \varnothing Threaded rods
 with $2\frac{1}{4} \times 2\frac{1}{4} \times \frac{5}{16}$ (55x55x8)
 \varnothing washers under each nut.
 All nuts shall be brought
 to a snug tight condition.
 Holes in the walls may be
 drilled using core bits in
 lieu of formed holes.

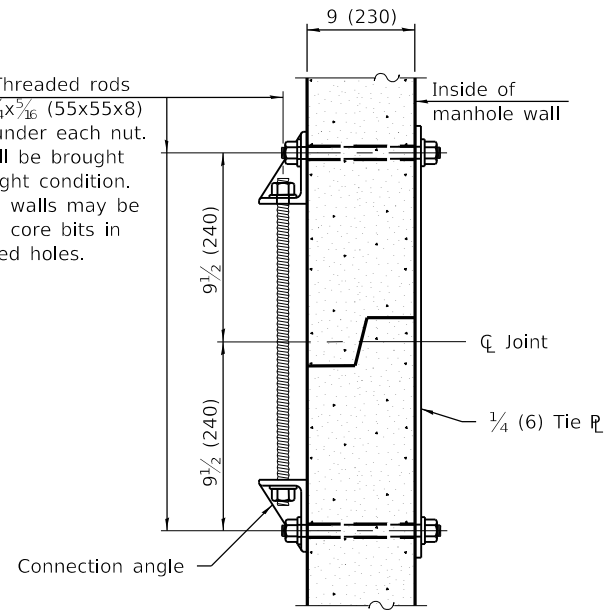

JOINT SPLICE

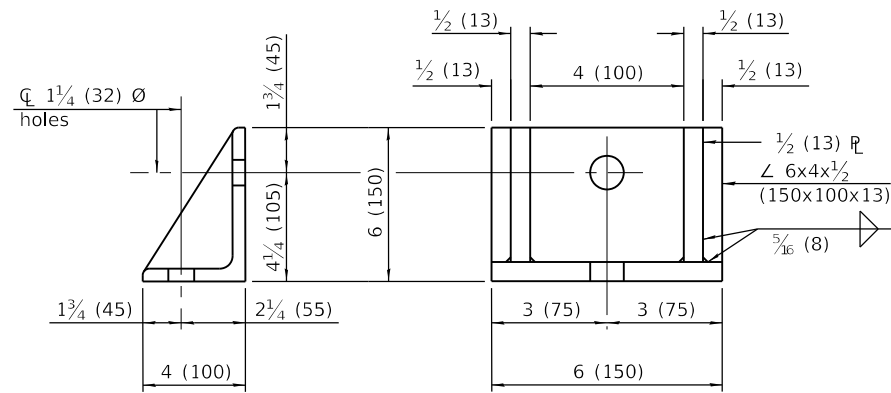

CONNECTION ANGLE

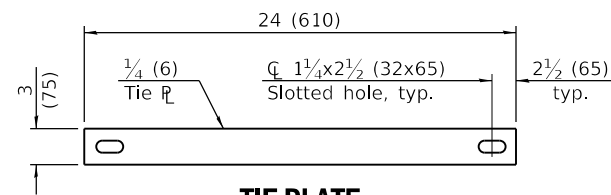

TIE PLATE

FLAT SLAB TOP REINFORCEMENT

Location	Riser Height (RH)	WWR (each direction)		Rebar (each direction except as noted)		
		A _s (min.)	Spacing (max.)	A _s (min.)	Spacing (max.)	Bar Size
Top Mat	All	0.11 sq. in./ft. (233 sq. mm/m)	18 (450)	0.11 sq. in./ft. (233 sq. mm/m)	18 (450)	#3 or #4 (#10) (#13)
Bottom Mat	RH ≤ 10 ft. (3.05 m)	** 0.88 sq. in./ft. (1863 sq. mm/m)	6 (150)	See plan view for rebar orientation and spacing and this table for bar size		#6 (#19)
	RH > 10 ft. (3.05 m)	WWR not permitted				#7 (#22)

** Only one layer of WWR permitted to avoid congestion.

WALL REINFORCEMENT

Location	Orientation	WWR or Rebar	
		A _s (min.)	Spacing (max.)
4 ft. (1.22 m) \varnothing Riser	Circumferential	0.12 sq. in./ft. (254 sq. mm/m)	6 (150)
	Vertical	0.045 sq. in./ft. (95 sq. mm/m)	8 (200)
8 ft. (2.44 m) \varnothing Barrel	Circumferential	0.24 sq. in./ft. (508 sq. mm/m)	6 (150)
	Vertical	0.045 sq. in./ft. (95 sq. mm/m)	8 (200)

BASE SLAB REINFORCEMENT

Location	Riser Height (RH)/ Total Height (TH)	WWR or Rebar (each direction)	
		A _s (min.)	Spacing (max.)
Top Mat	RH ≤ 10 ft. (3.05 m) & TH ≤ 20 ft. (6.10 m)	0.36 sq. in./ft. (762 sq. mm/m)	6 (150)
	RH > 10 ft. (3.05 m) or TH > 20 ft. (6.10 m)	0.60 sq. in./ft. (1270 sq. mm/m)	6 (150)
Bottom Mat	All	0.11 sq. in./ft. (233 sq. mm/m)	18 (450)

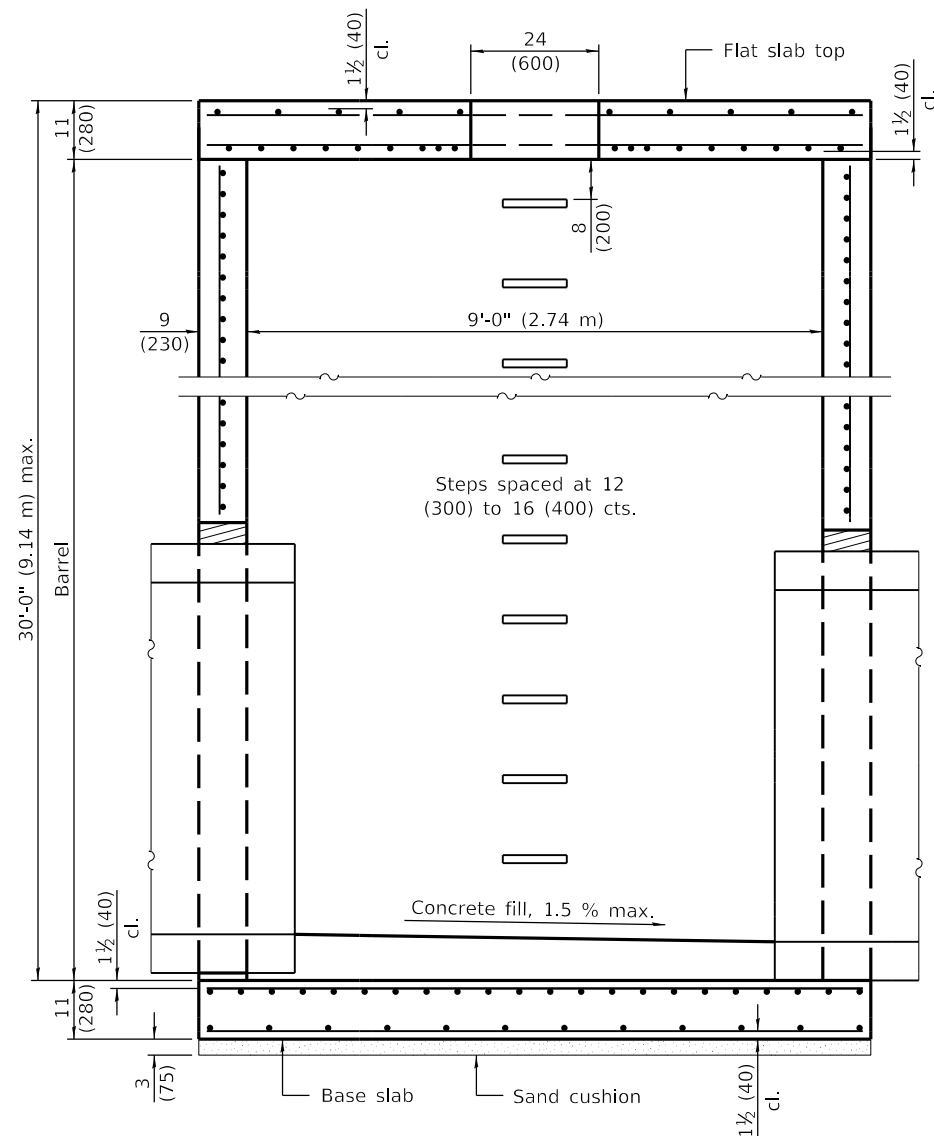

SECTION PARALLEL TO PIPE
(Without conical top riser)

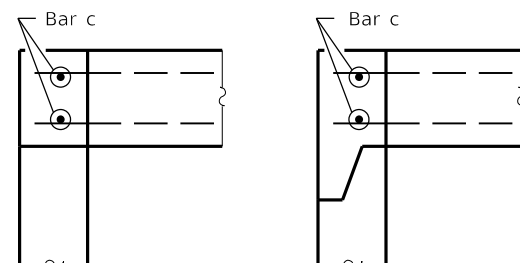

FLAT SLAB TOP JOINT CONFIGURATIONS
(Shown at access hole)

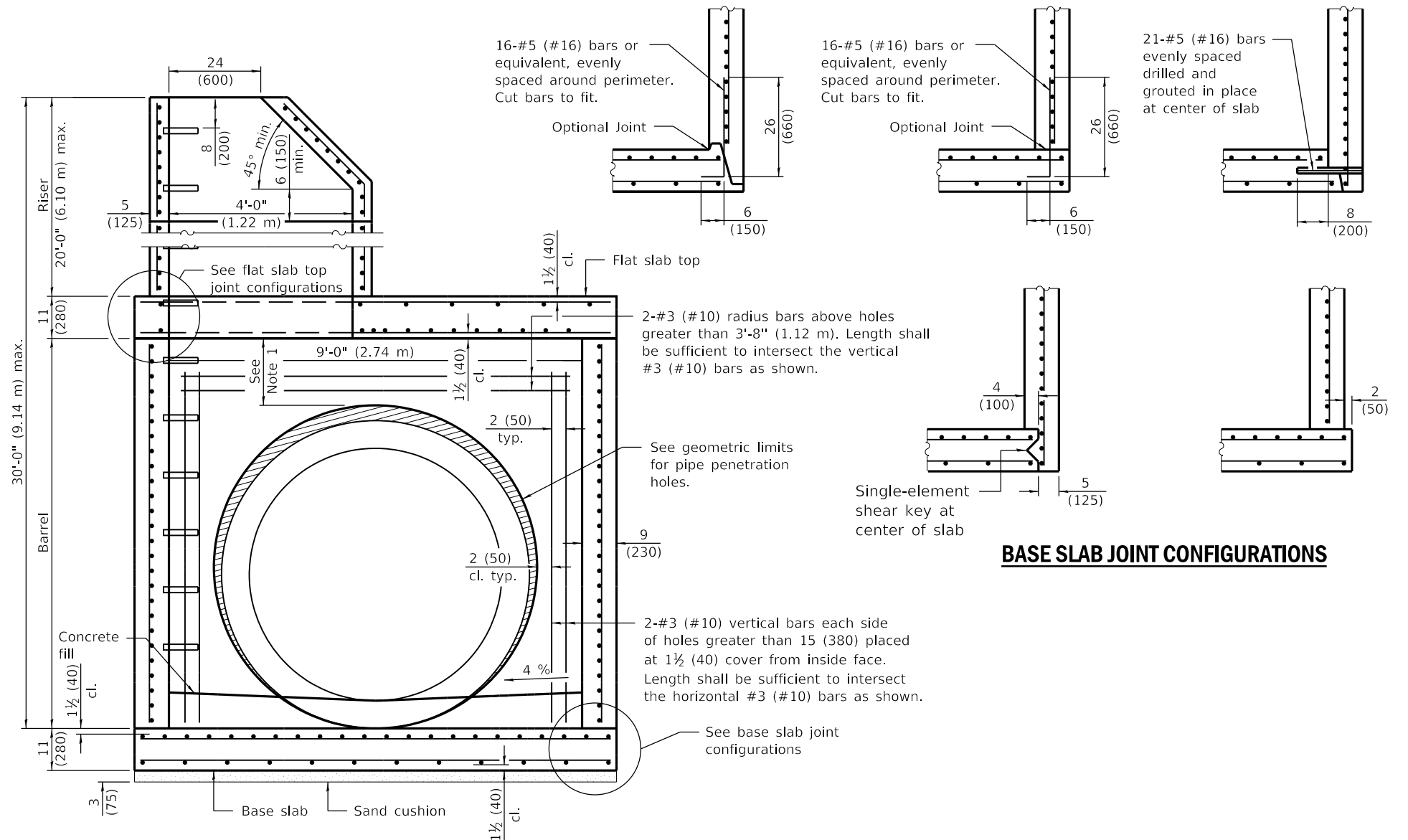

SECTION PERPENDICULAR TO PIPE
(With conical top riser)

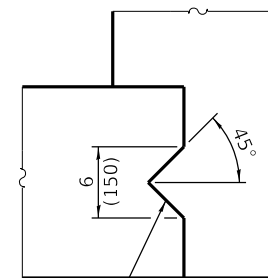

Single-element shear key at center of slab

SHEAR KEY GEOMETRY
(Reinforcement not shown for clarity)

BASE SLAB JOINT CONFIGURATIONS

GEOMETRIC LIMITS FOR PIPE PENETRATION HOLES

- Note 1: A minimum of 12 (300) of monolithic reinforced concrete shall be maintained above pipe penetration holes > 3'-8" (1.12 m).
- Note 2: A minimum 12 (300) inside arc length of reinforced concrete shall be maintained between pipe penetration holes > 15 (380).
- Note 3: A maximum of 60 percent of the inside perimeter of the reinforced concrete manhole walls may be removed.
- Note 4: Horizontal joints that intersect pipe penetration holes > 15 (380) shall have one joint splice for every location around the perimeter of the joint where the inside arc length between pipe penetration holes is < 24 (600). See joint splice detail.
- Note 5: The recommended pipe penetration hole is equal to the O.D. of the pipe plus 4 (100).
- Note 6: Only pipe penetration holes ≤ 15 (380) are allowed in riser sections.

DATE	REVISIONS
1-1-21	Revised Note 1 and lifting hole general note.
3-1-19	Moved wall reinforcement from inside face to middle.

GENERAL NOTES

- Pipe holes shall be formed to facilitate proper placement of hole reinforcement.
- The manufacturer shall ensure that all precast manhole sections are additionally reinforced where required to resist damage from handling, shipping and installation stresses.
- Lifting holes shall be located in the sections as per the manufacturer's recommendations.
- See Standard 602701 for details of manhole steps.
- All dimensions are in inches (millimeters) unless otherwise noted.

PRECAST MANHOLE TYPE A
9' (2.74 m) DIAMETER

(Sheet 1 of 3)

STANDARD 602421-09

Illinois Department of Transportation

PASSED January 1, 2021
Michael Bond
ENGINEER OF POLICY AND PROCEDURES

APPROVED January 1, 2021
J. E. ...
ENGINEER OF DESIGN AND ENVIRONMENT

ISSUED 4-1-06

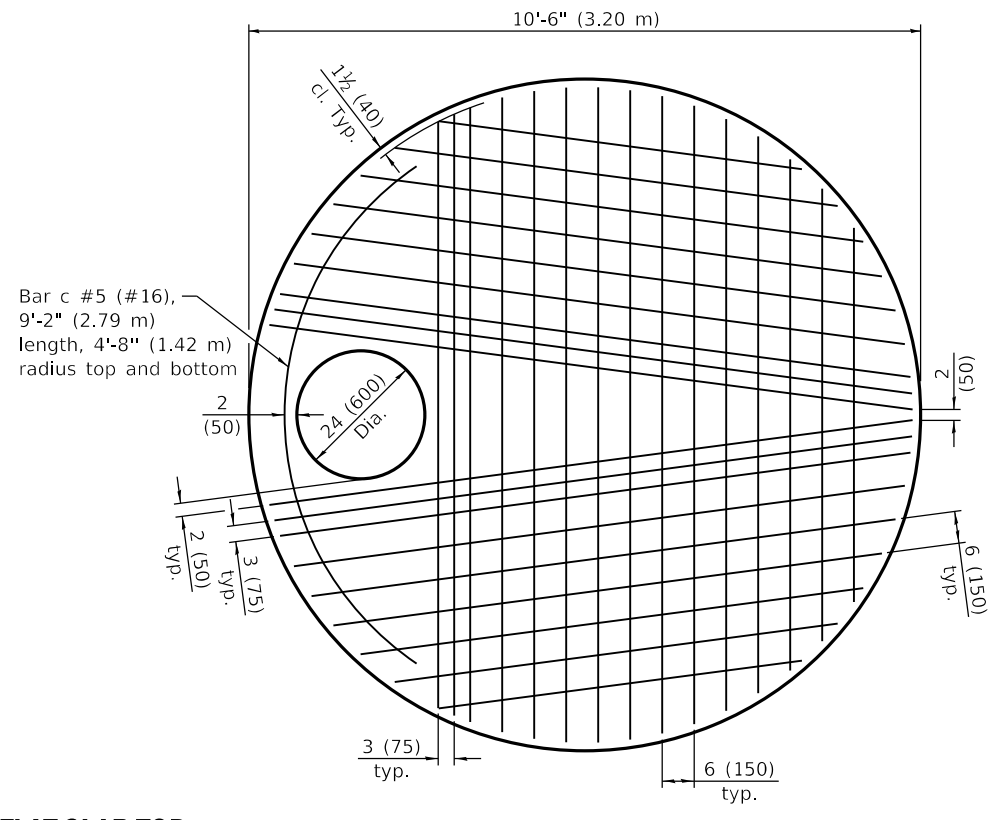
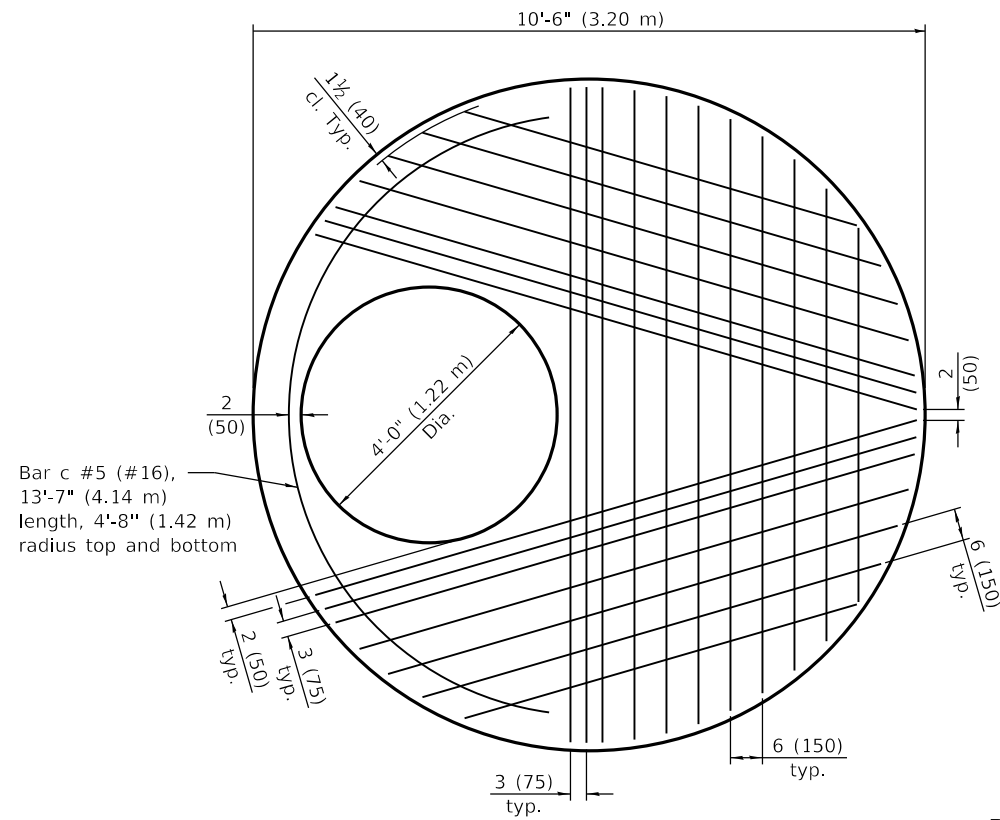

PLAN - FLAT SLAB TOP

(Showing layout of bottom reinforcement bars and c bars)

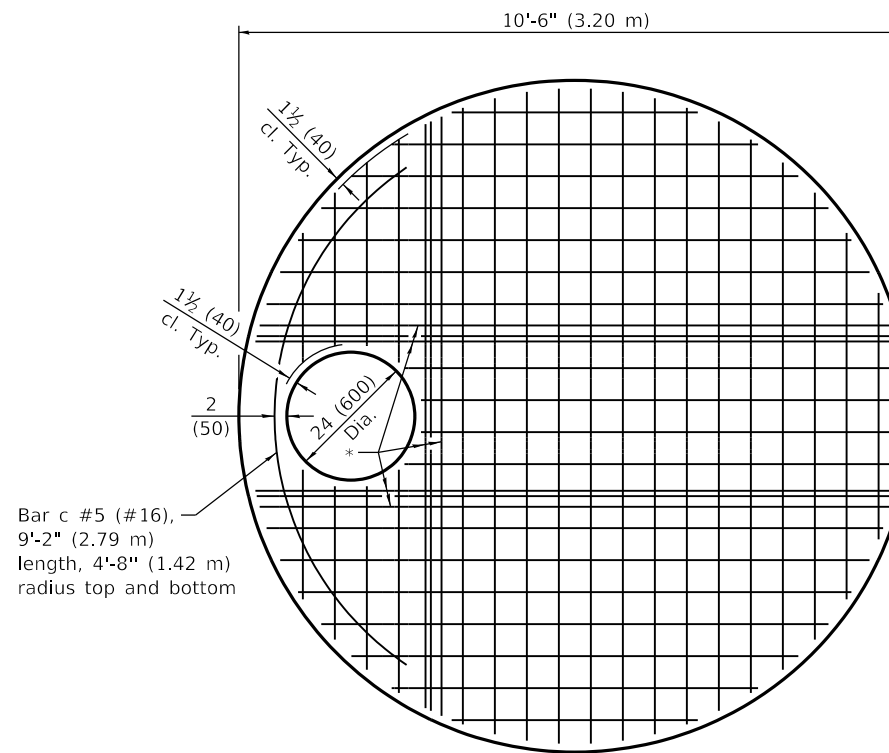
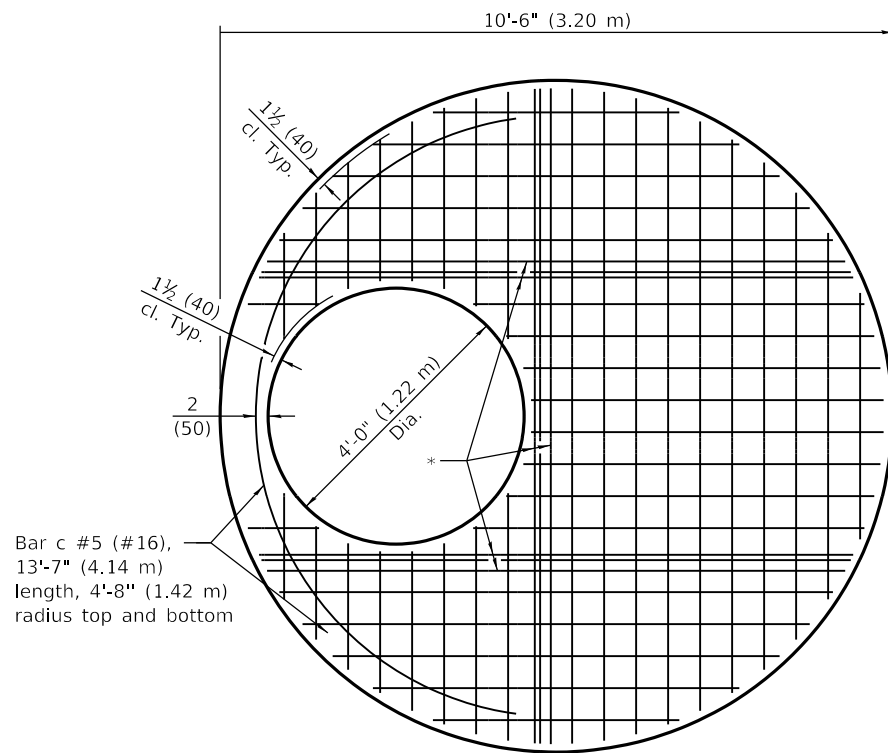

PLAN - FLAT SLAB TOP

(Showing layout of welded wire reinforcement and c bars)
WWR not permitted for riser heights > 10' (3.05 m).

* #6 (#19) bars bottom. Bundle first bar with closest WWR bar to the opening and place second bar ±3 (75) away.

Illinois Department of Transportation

PASSED January 1, 2021

 ENGINEER OF POLICY AND PROCEDURES

APPROVED January 1, 2021

 ENGINEER OF DESIGN AND ENVIRONMENT

ISSUED 4-1-06

PRECAST MANHOLE TYPE A
9' (2.74 m) DIAMETER

(Sheet 2 of 3)

STANDARD 602421-09

\varnothing 1(25) \varnothing Threaded rods with $2\frac{1}{4} \times 2\frac{1}{4} \times \frac{5}{16}$ (55x55x8) \varnothing washers under each nut. All nuts shall be brought to a snug tight condition. Holes in the walls may be drilled using core bits in lieu of formed holes.

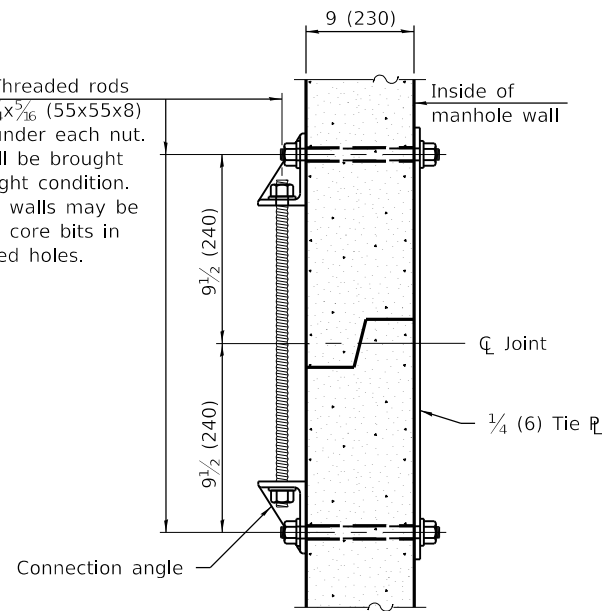

JOINT SPLICE

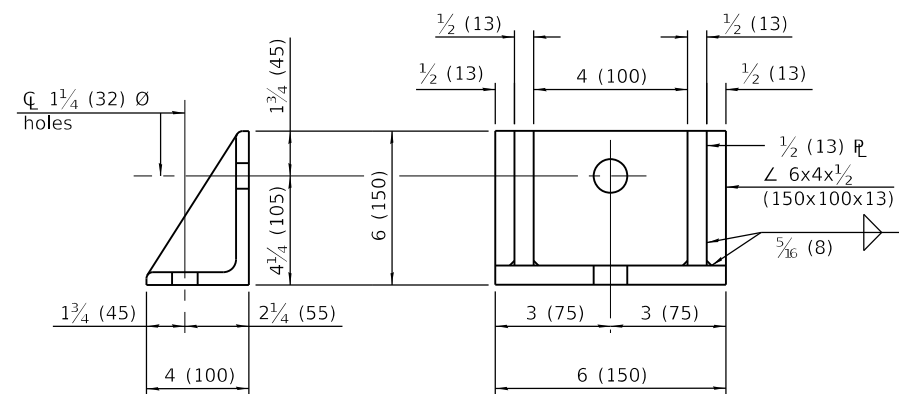

CONNECTION ANGLE

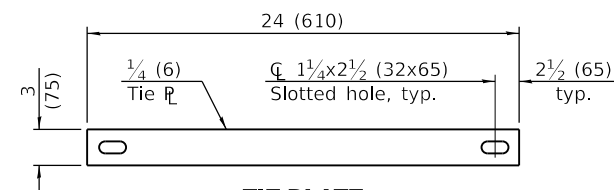

TIE PLATE

FLAT SLAB TOP REINFORCEMENT

Location	Riser Height (RH)	WWR (each direction)		Rebar (each direction except as noted)		
		A_s (min.)	Spacing (max.)	A_s (min.)	Spacing (max.)	Bar Size
Top Mat	All	0.11 sq. in./ft. (233 sq. mm/m)	18 (450)	0.11 sq. in./ft. (233 sq. mm/m)	18 (450)	#3 or #4 (#10) (#13)
Bottom Mat	RH \leq 10 ft. (3.05 m)	** 0.88 sq. in./ft. (1863 sq. mm/m)	6 (150)	See plan view for rebar orientation and spacing and this table for bar size		#6 (#19)
	RH > 10 ft. (3.05 m)	WWR not permitted				#8 (#25)

** Only one layer of WWR permitted to avoid congestion.

WALL REINFORCEMENT

Location	Orientation	WWR or Rebar	
		A_s (min.)	Spacing (max.)
4 ft. (1.22 m) \varnothing Riser	Circumferential	0.12 sq. in./ft. (254 sq. mm/m)	6 (150)
	Vertical	0.045 sq. in./ft. (95 sq. mm/m)	8 (200)
9 ft. (2.74 m) \varnothing Barrel	Circumferential	0.27 sq. in./ft. (572 sq. mm/m)	6 (150)
	Vertical	0.045 sq. in./ft. (95 sq. mm/m)	8 (200)

BASE SLAB REINFORCEMENT

Location	Riser Height (RH)/ Total Height (TH)	WWR or Rebar (each direction)	
		A_s (min.)	Spacing (max.)
Top Mat	RH \leq 10 ft. (3.05 m) & TH \leq 20 ft. (6.10 m)	0.44 sq. in./ft. (931 sq. mm/m)	6 (150)
	RH > 10 ft. (3.05 m) or TH > 20 ft. (6.10 m)	0.72 sq. in./ft. (1524 sq. mm/m)	6 (150)
Bottom Mat	All	0.11 sq. in./ft. (233 sq. mm/m)	18 (450)

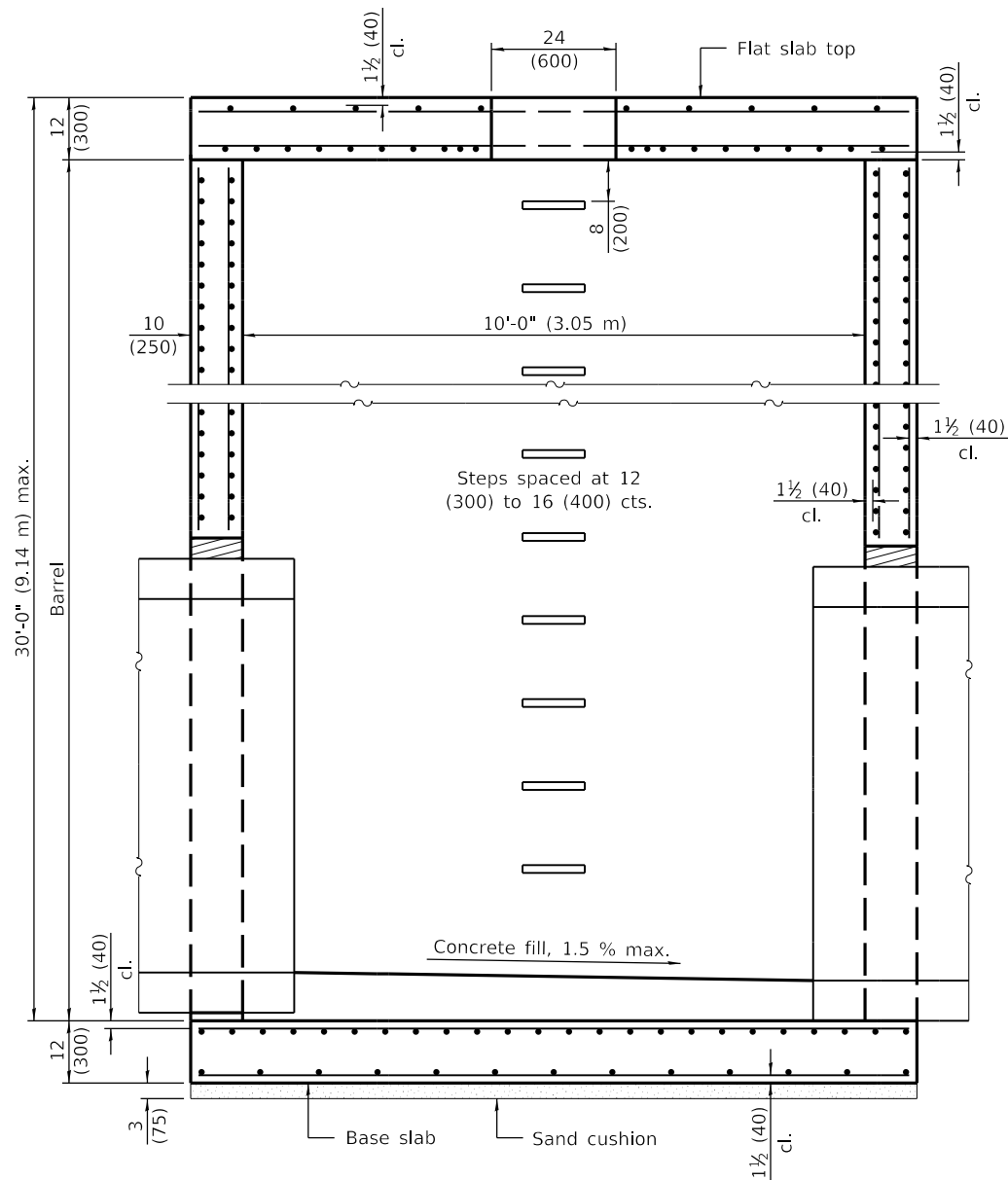

SECTION PARALLEL TO PIPE
(Without conical top riser)

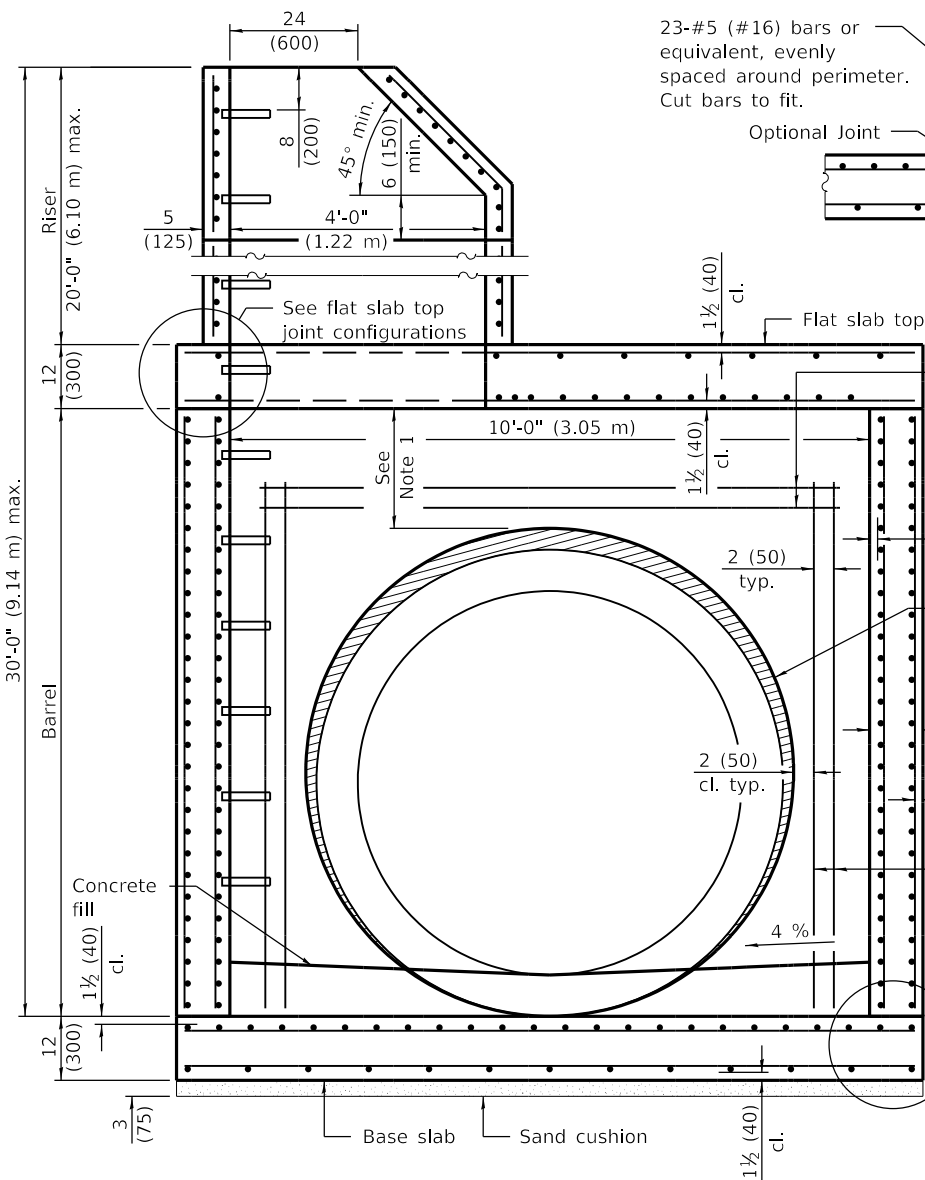

SECTION PERPENDICULAR TO PIPE
(With conical top riser)

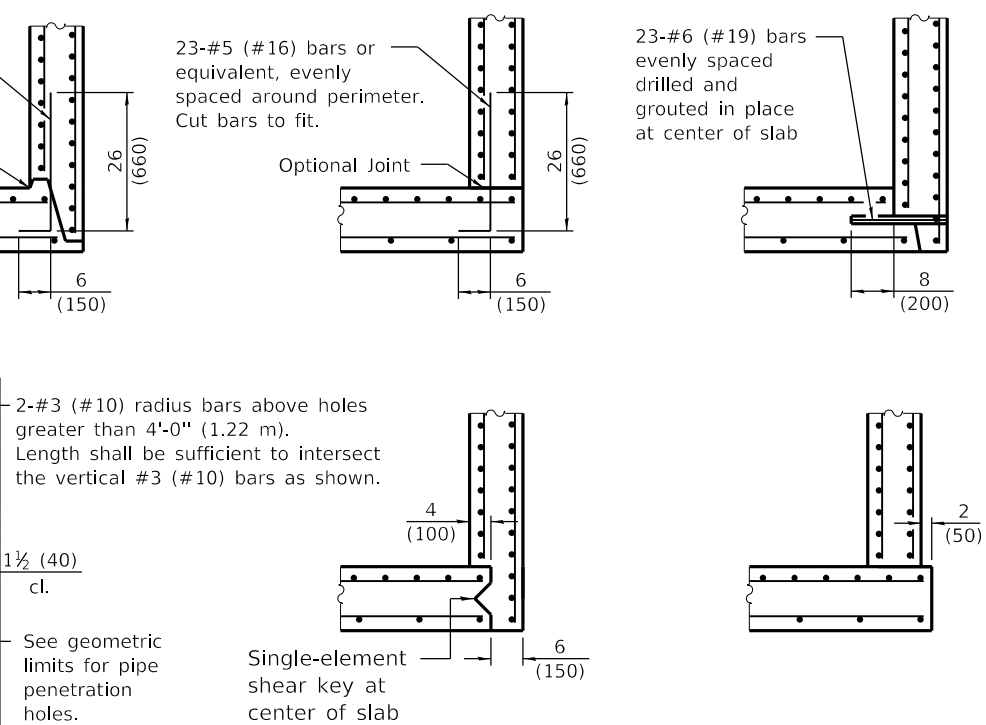

BASE SLAB JOINT CONFIGURATIONS

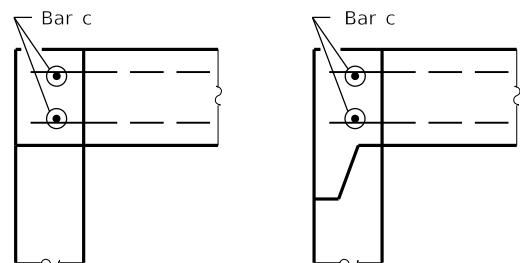

FLAT SLAB TOP JOINT CONFIGURATIONS
(Shown at access hole)

GEOMETRIC LIMITS FOR PIPE PENETRATION HOLES

- Note 1: A minimum of 12 (300) of monolithic reinforced concrete shall be maintained above pipe penetration holes > 4'-0" (1.22 m).
- Note 2: A minimum 12 (300) inside arc length of reinforced concrete shall be maintained between pipe penetration holes > 15 (380).
- Note 3: A maximum of 60 percent of the inside perimeter of the reinforced concrete manhole walls may be removed.
- Note 4: Horizontal joints that intersect pipe penetration holes > 15 (380) shall have one joint splice for every location around the perimeter of the joint where the inside arc length between pipe penetration holes is < 24 (600). See joint splice detail.
- Note 5: The recommended pipe penetration hole is equal to the O.D. of the pipe plus 4 (100).
- Note 6: Only pipe penetration holes ≤ 15 (380) are allowed in riser sections.

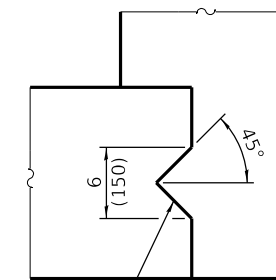

Single-element shear key at center of slab

SHEAR KEY GEOMETRY
(Reinforcement not shown for clarity)

GENERAL NOTES

- Pipe holes shall be formed to facilitate proper placement of hole reinforcement.
- The manufacturer shall ensure that all precast manhole sections are additionally reinforced where required to resist damage from handling, shipping and installation stresses.
- Lifting holes shall be located in the sections as per the manufacturer's recommendations.
- See Standard 602701 for details of manhole steps.
- All dimensions are in inches (millimeters) unless otherwise noted.

DATE	REVISIONS
1-1-21	Revised Note 1.
3-1-19	Moved wall reinforcement of 4'-0" (1.22 m) riser from inside face to middle.

PRECAST MANHOLE TYPE A
10' (3.05 m) DIAMETER

(Sheet 1 of 3)

STANDARD 602426-03

Illinois Department of Transportation

PASSED January 1, 2021

ENGINEER OF POLICY AND PROCEDURES

APPROVED January 1, 2021

ENGINEER OF DESIGN AND ENVIRONMENT

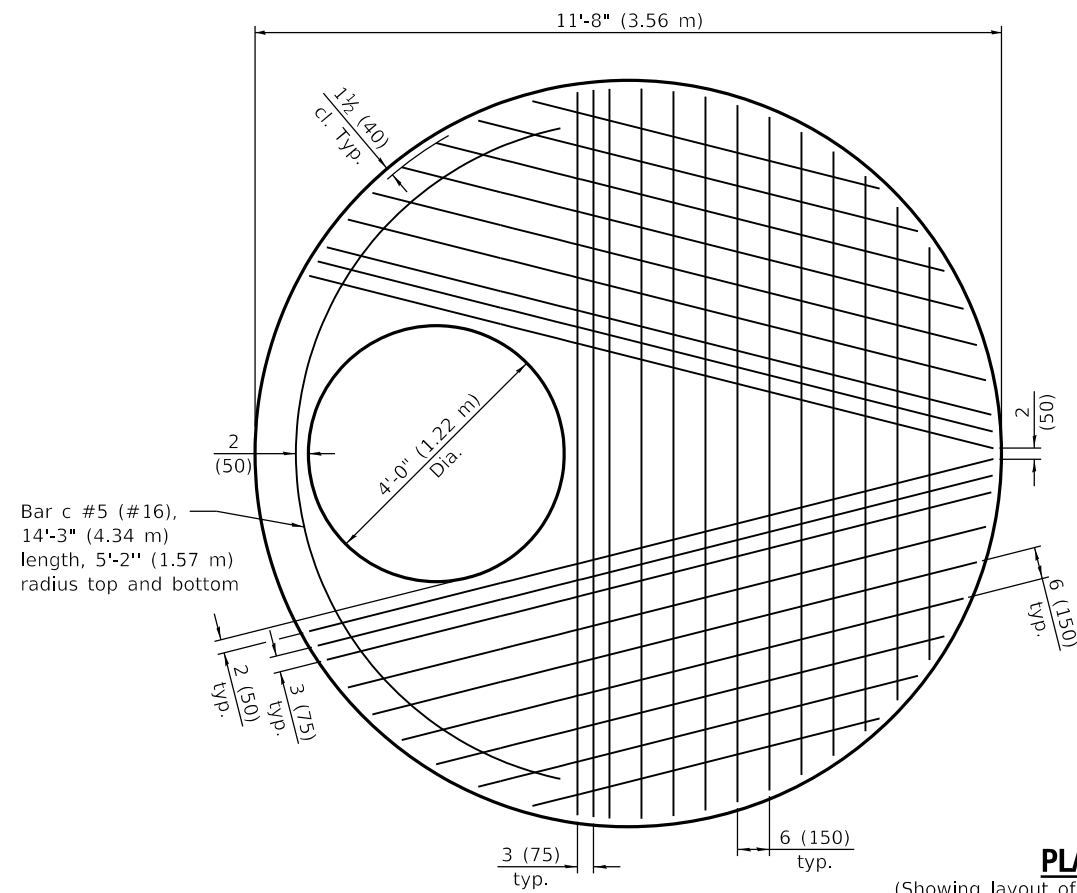

PLAN - FLAT SLAB TOP

(Showing layout of bottom reinforcement bars and c bars)

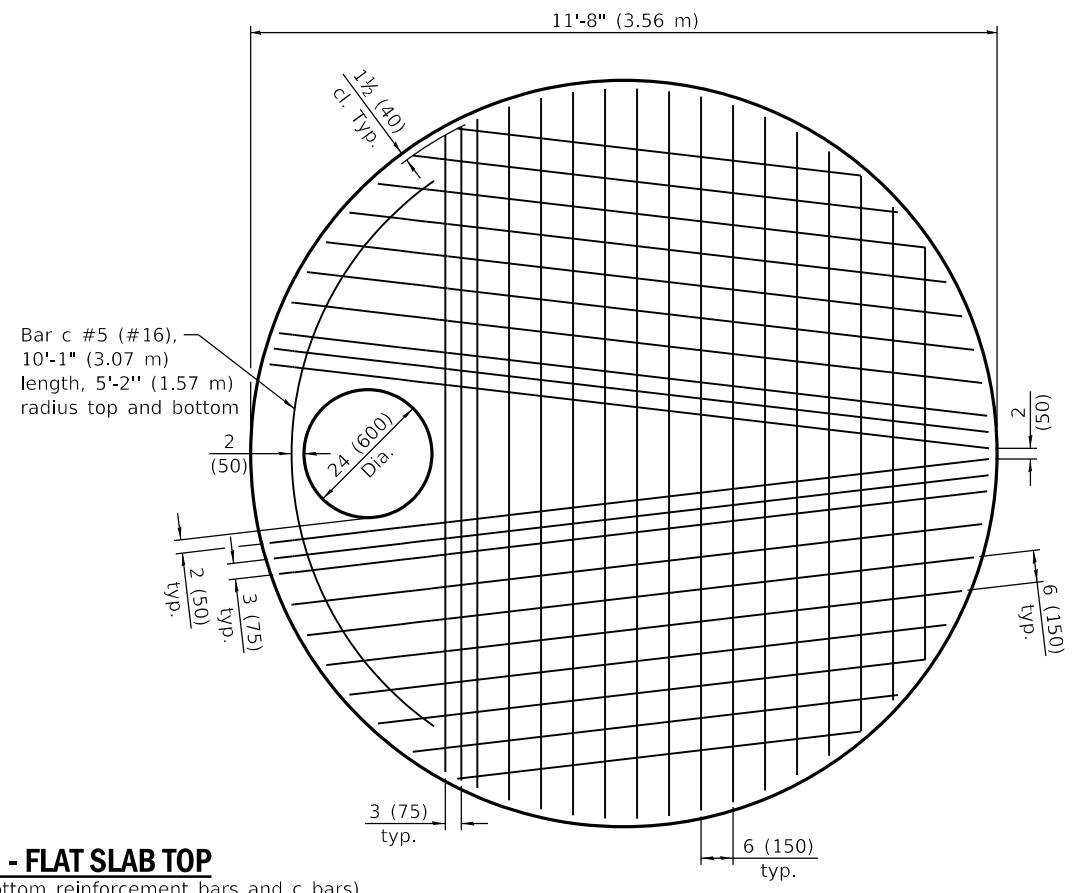

PLAN - FLAT SLAB TOP

(Showing layout of welded wire reinforcement and c bars)
WWR not permitted for riser heights > 10' (3.05 m).

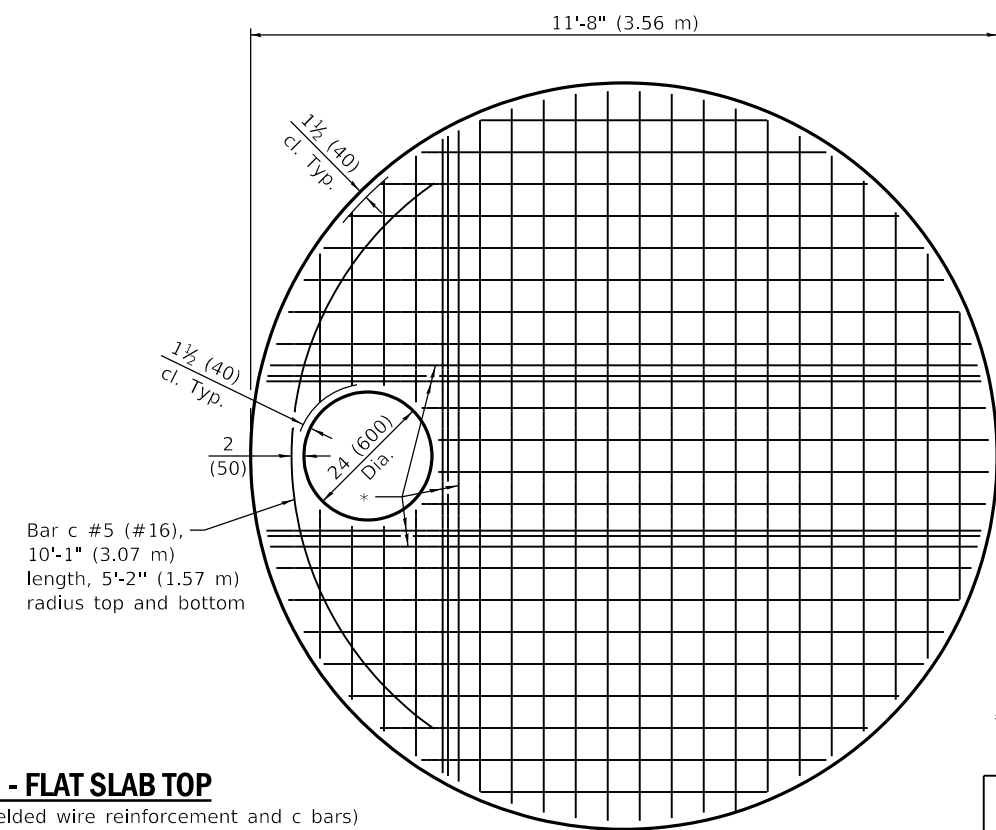
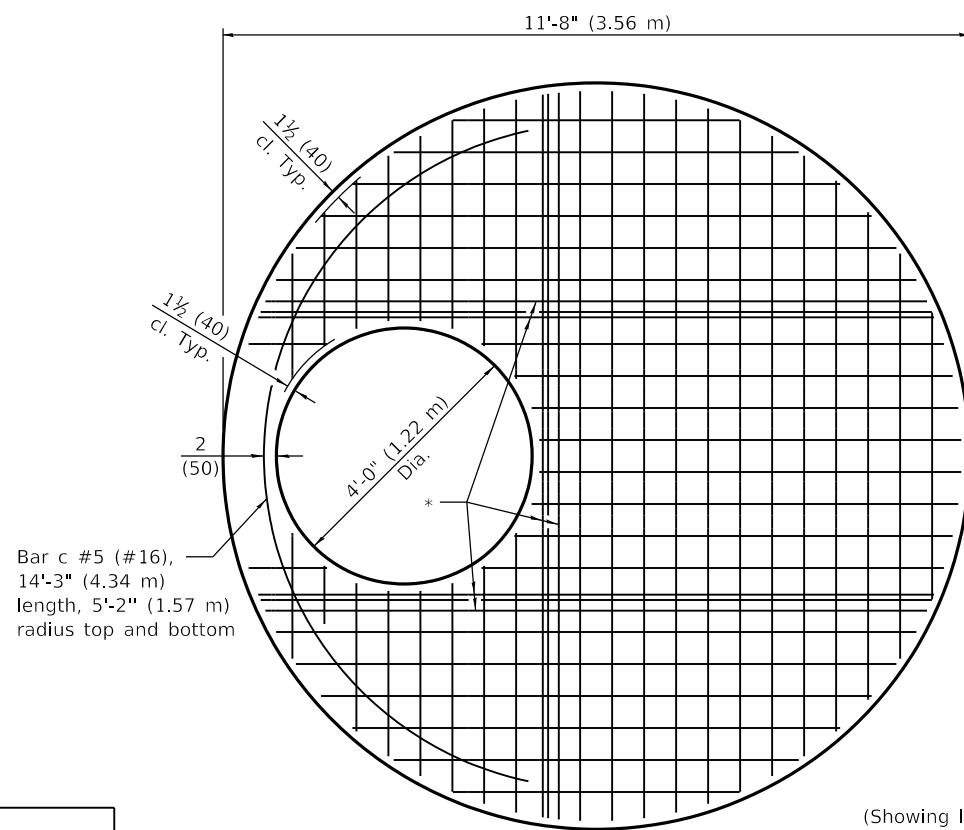

* #6 (#19) bars bottom. Bundle first bar with closest WWR bar to the opening and place second bar ±3 (75) away.

Illinois Department of Transportation

PASSED January 1, 2021
Michael Bond
ENGINEER OF POLICY AND PROCEDURES

APPROVED January 1, 2021
J. E. C. G.
ENGINEER OF DESIGN AND ENVIRONMENT

ISSUED 1-1-18

**PRECAST MANHOLE TYPE A
10' (3.05 m) DIAMETER**

(Sheet 2 of 3)

STANDARD 602426-03

\varnothing 1(25) \varnothing Threaded rods with $2\frac{1}{4} \times 2\frac{1}{4} \times \frac{3}{16}$ (55x55x8) \varnothing washers under each nut. All nuts shall be brought to a snug tight condition. Holes in the walls may be drilled using core bits in lieu of formed holes.

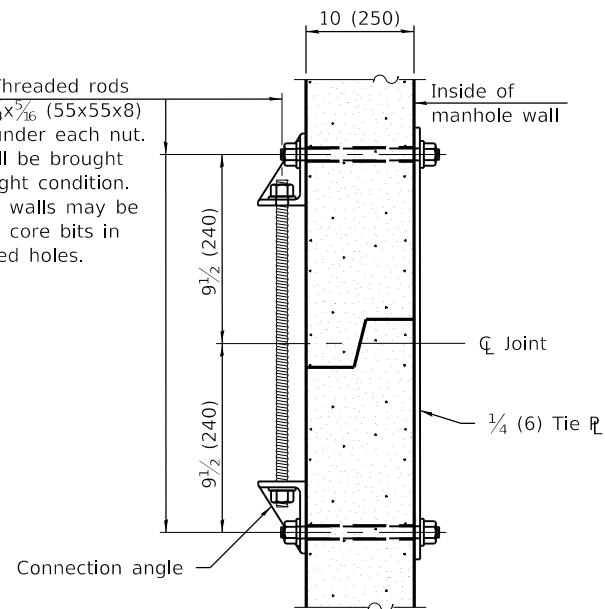

JOINT SPLICE

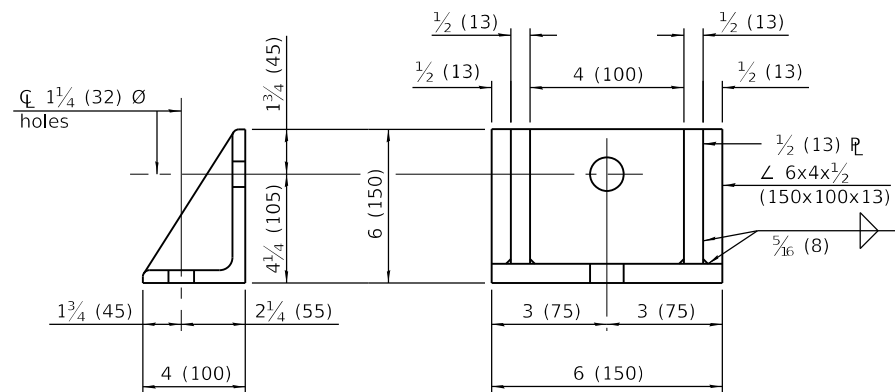

CONNECTION ANGLE

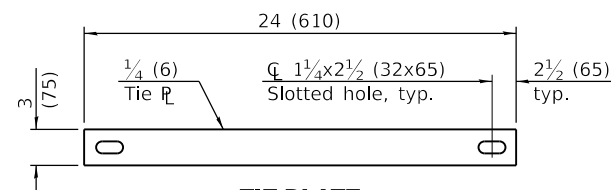

TIE PLATE

FLAT SLAB TOP REINFORCEMENT

Location	Riser Height (RH)	WWR (each direction)		Rebar (each direction except as noted)		
		A _s (min.)	Spacing (max.)	A _s (min.)	Spacing (max.)	Bar Size
Top Mat	All	0.11 sq. in./ft. (233 sq. mm/m)	18 (450)	0.11 sq. in./ft. (233 sq. mm/m)	18 (450)	#3 or #4 (#10) (#13)
Bottom Mat	RH ≤ 10 ft. (3.05 m)	** 0.88 sq. in./ft. (1863 sq. mm/m)	6 (150)	See plan view for rebar orientation and spacing and this table for bar size		#6 (#19)
	RH > 10 ft. (3.05 m)	WWR not permitted				#8 (#25)

** Only one layer of WWR permitted to avoid congestion.

WALL REINFORCEMENT

Location	Orientation	WWR or Rebar	
		A _s (min.)	Spacing (max.)
4 ft. (1.22 m) \varnothing Riser	Circumferential	0.12 sq. in./ft. (254 sq. mm/m)	6 (150)
	Vertical	0.045 sq. in./ft. (95 sq. mm/m)	8 (200)
10 ft. (3.05 m) \varnothing Barrel Inside Mat	Circumferential	0.30 sq. in./ft. (635 sq. mm/m)	6 (150)
	Vertical	0.045 sq. in./ft. (95 sq. mm/m)	8 (200)
10 ft. (3.05 m) \varnothing Barrel Outside Mat	Circumferential	0.11 sq. in./ft. (233 sq. mm/m)	6 (150)
	Vertical	0.045 sq. in./ft. (95 sq. mm/m)	8 (200)

BASE SLAB REINFORCEMENT

Location	Riser Height (RH)/ Total Height (TH)	WWR or Rebar (each direction)	
		A _s (min.)	Spacing (max.)
Top Mat	RH ≤ 10 ft. (3.05 m) & TH ≤ 20 ft. (6.10 m)	0.48 sq. in./ft. (889 sq. mm/m)	6 (150)
	RH > 10 ft. (3.05 m) or TH > 20 ft. (6.10 m)	0.78 sq. in./ft. (1651 sq. mm/m)	6 (150)
Bottom Mat	All	0.11 sq. in./ft. (233 sq. mm/m)	18 (450)

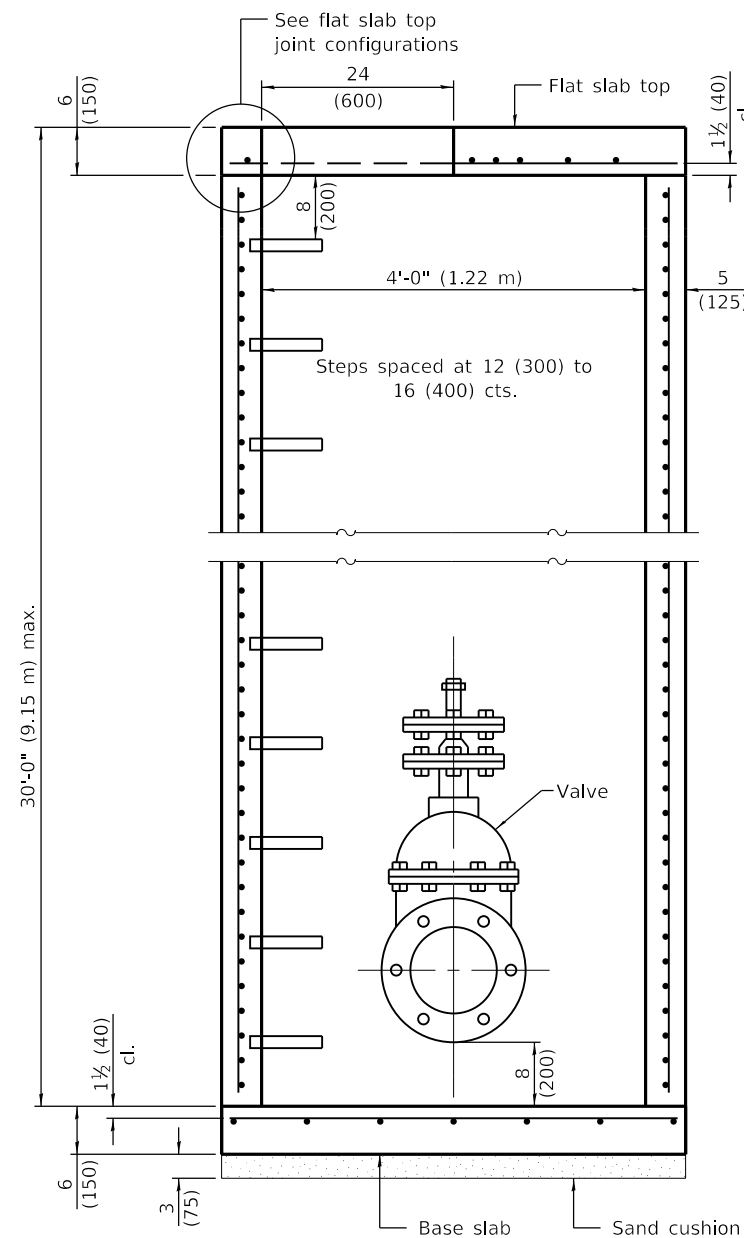

SECTION THRU VALVE VAULT
(Without conical top)

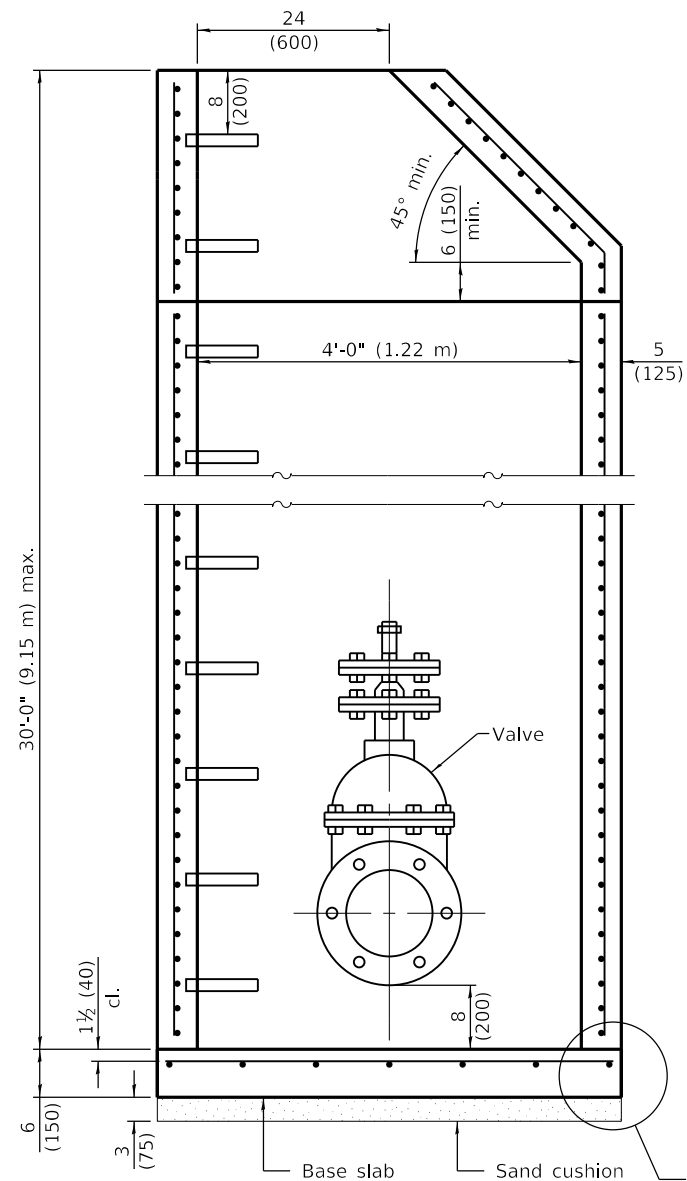

SECTION THRU VALVE VAULT
(With conical top)

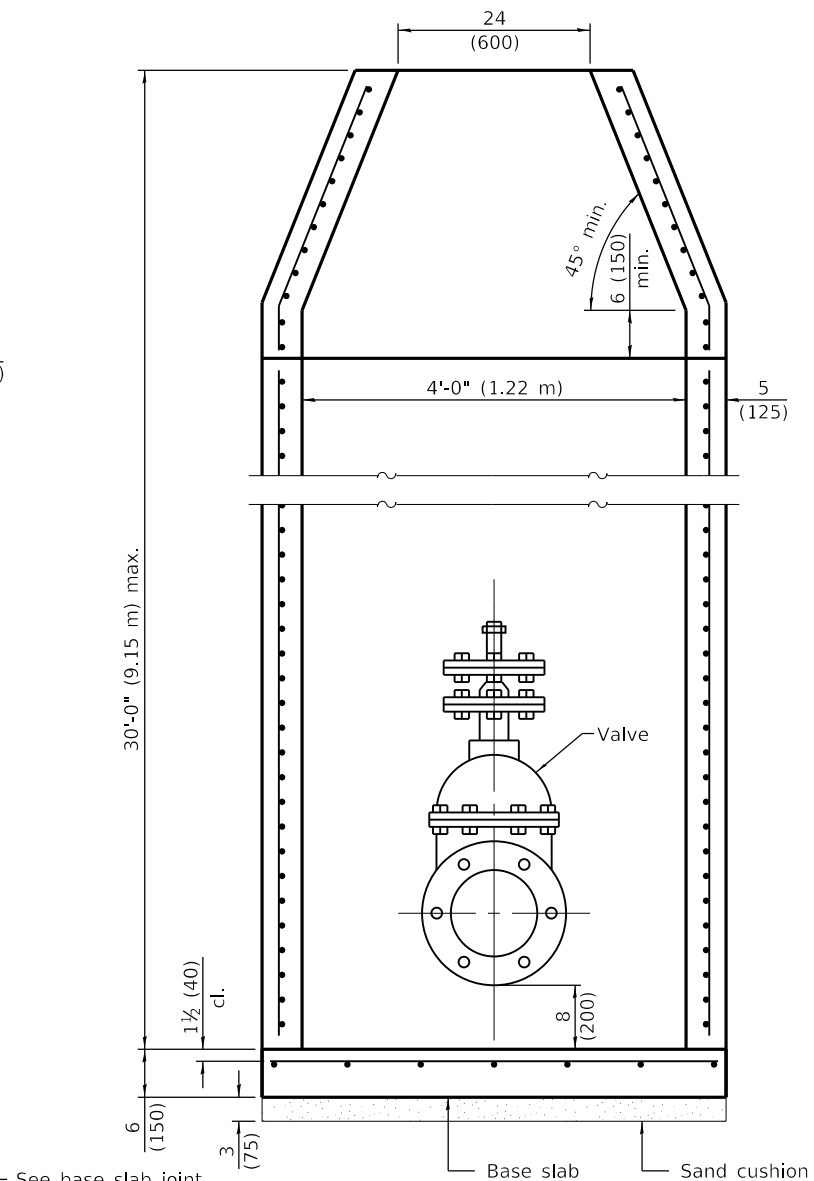

SECTION THRU VALVE VAULT
(With concentric conical top)

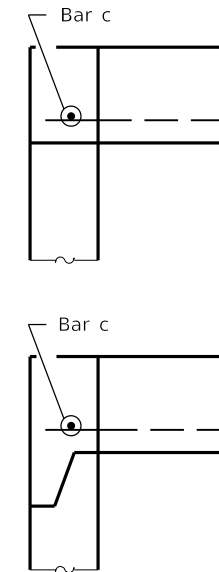

FLAT SLAB TOP JOINT CONFIGURATIONS
(Shown at access hole)

GENERAL NOTES

Use this standard for water mains \leq 8 (200).

The manufacturer shall ensure that all precast manhole sections are additionally reinforced where required to resist damage from handling, shipping and installation stresses.

Lifting holes shall be located in the sections as per the manufacturer's recommendations.

See Standard 602701 for details of manhole steps.

All dimensions are in inches (millimeters) unless otherwise noted.

DATE	REVISIONS
1-1-21	Revised lifting hole general note.
3-1-19	Moved wall reinforcement from inside face to middle.

PRECAST VALVE VAULT TYPE A
4' (1.22 m) DIAMETER

(Sheet 1 of 2)

STANDARD 602501-06

Illinois Department of Transportation

PASSED January 1, 2021

 ENGINEER OF POLICY AND PROCEDURES

APPROVED January 1, 2021

 ENGINEER OF DESIGN AND ENVIRONMENT

ISSUED 1-1-97

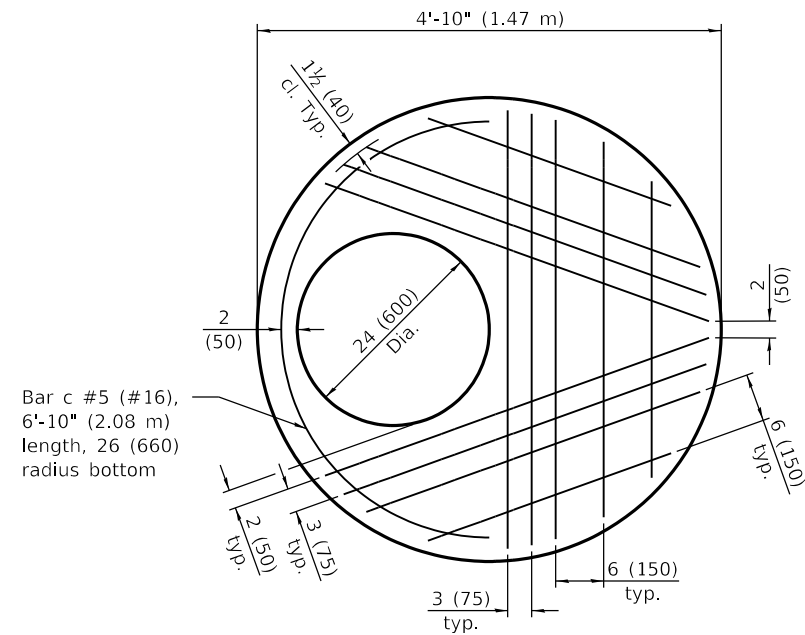

Bar c #5 (#16),
6'-10" (2.08 m)
length, 26 (660)
radius bottom

PLAN - FLAT SLAB TOP

(Showing layout of reinforcement bars and c bars)

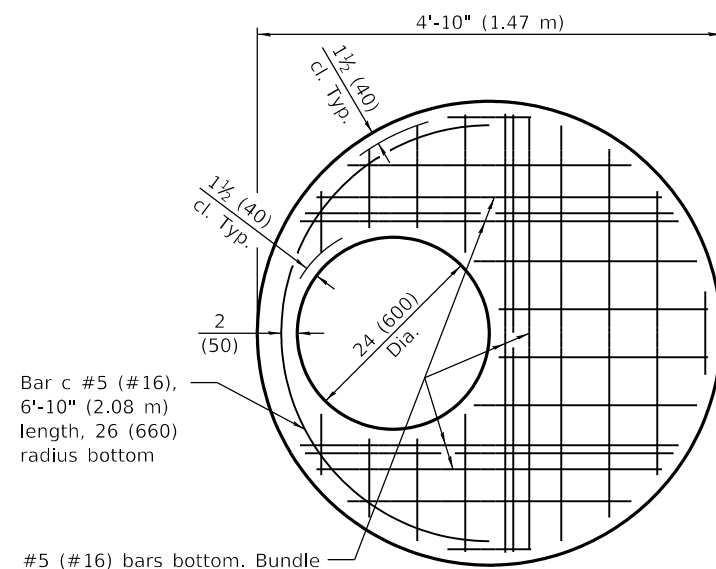

Bar c #5 (#16),
6'-10" (2.08 m)
length, 26 (660)
radius bottom

#5 (#16) bars bottom. Bundle
first bar with closest WWR bar
to the opening and place
second bar ±3 (75) away.

PLAN - FLAT SLAB TOP

(Showing layout of welded wire reinforcement and c bars)

FLAT SLAB TOP REINFORCEMENT

Location	WWR (each direction)		Rebar		
	A _s (min.)	Spacing (max.)	A _s (min.)	Spacing (max.)	Bar Size
Bottom Mat	* 0.62 sq. in./ft. (1312 sq. mm/m)	6 (150)	See plan view for rebar orientation and spacing and this table for bar size		#5 (#16)

* Only one layer of WWR permitted to avoid congestion.

WALL REINFORCEMENT

Orientation	WWR or Rebar	
	A _s (min.)	Spacing (max.)
Circumferential	0.12 sq. in./ft. (254 sq. mm/m)	6 (150)
Vertical	0.045 sq. in./ft. (95 sq. mm/m)	8 (200)

BASE SLAB REINFORCEMENT

Location	Total Height	WWR or Rebar (each direction)	
		A _s (min.)	Spacing (max.)
Top Mat	≤ 20 ft. (6.10 m)	0.24 sq. in./ft. (508 sq. mm/m)	10 (250)
	> 20 ft. (6.10 m)	0.24 sq. in./ft. (508 sq. mm/m)	10 (250)

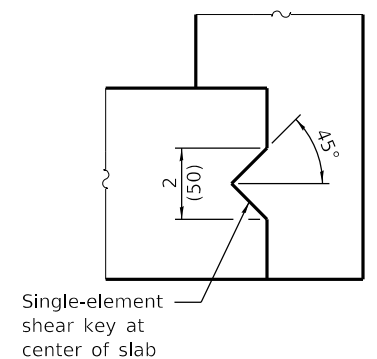
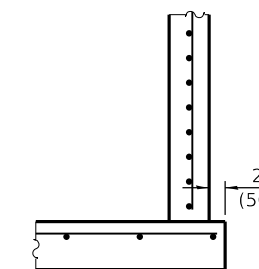
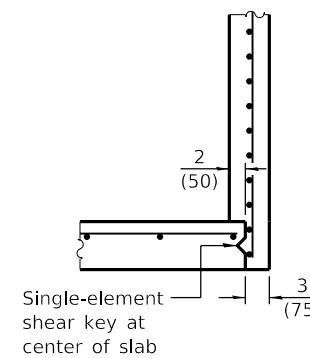
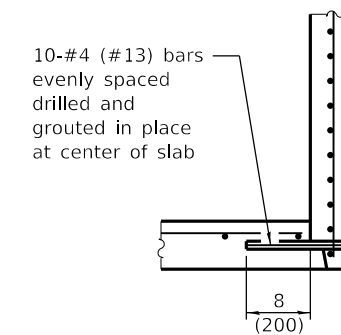
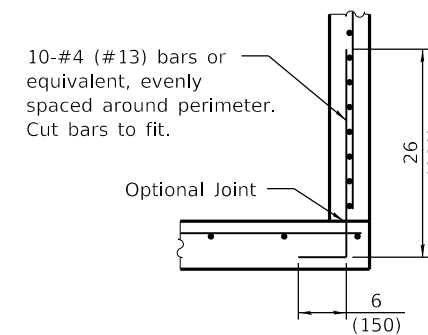
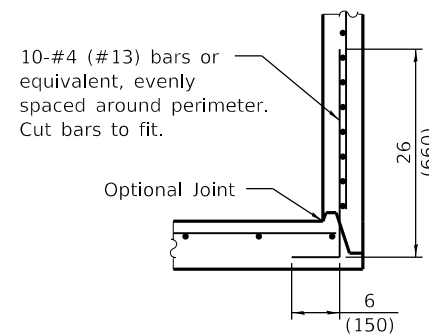

SHEAR KEY GEOMETRY
(Reinforcement not shown for clarity)

BASE SLAB JOINT CONFIGURATIONS

Illinois Department of Transportation

PASSED January 1, 2021

 ENGINEER OF POLICY AND PROCEDURES

APPROVED January 1, 2021

 ENGINEER OF DESIGN AND ENVIRONMENT

ISSUED 1-1-97

PRECAST VALVE VAULT TYPE A
4' (1.22 m) DIAMETER

(Sheet 2 of 2)

STANDARD 602501-06

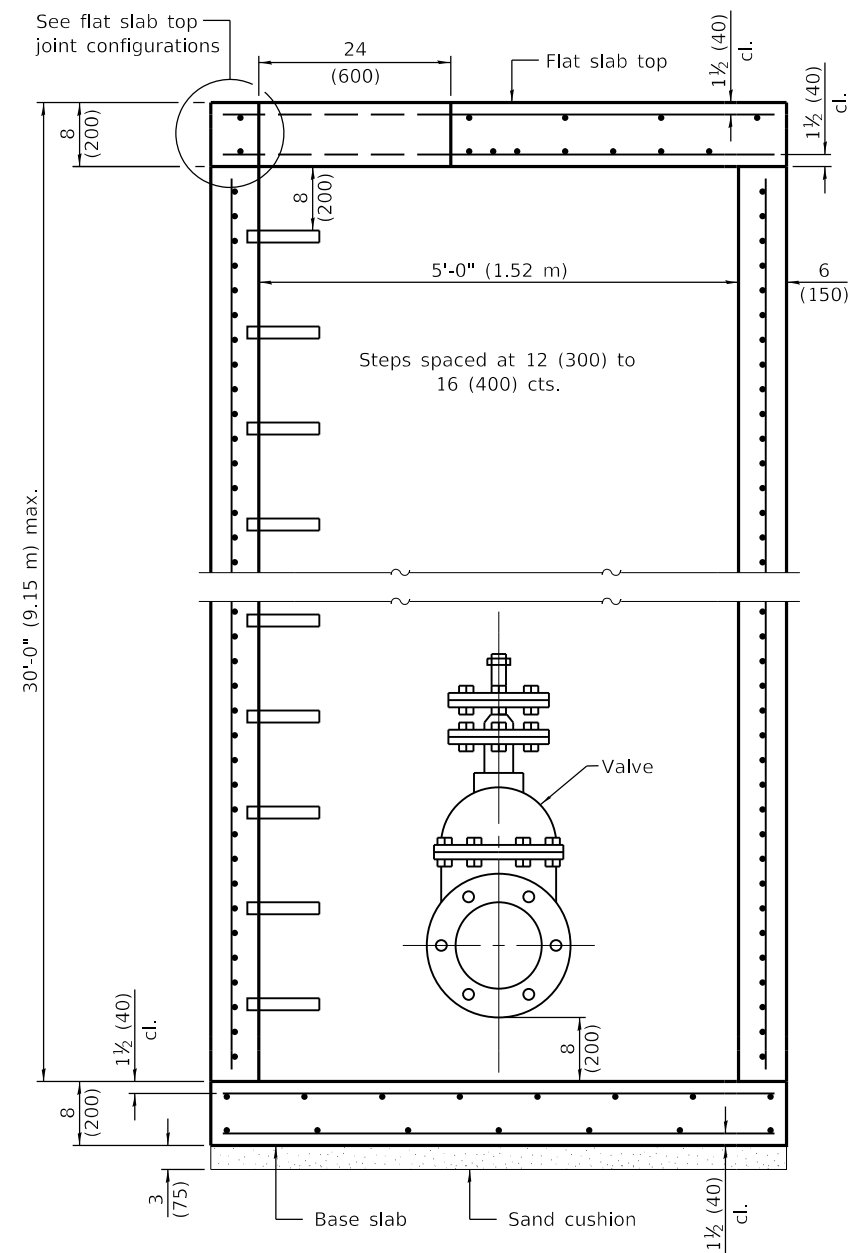

SECTION THRU VALVE VAULT
(Without conical top)

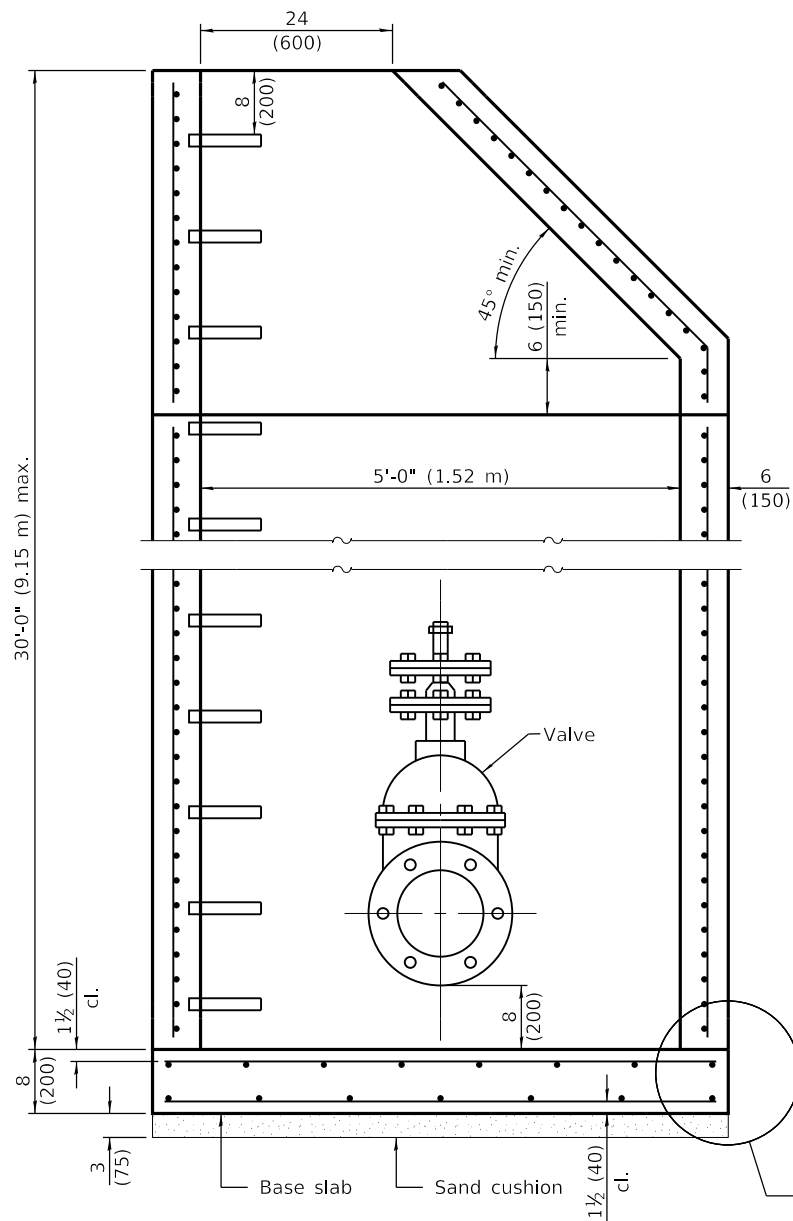

SECTION THRU VALVE VAULT
(With conical top)

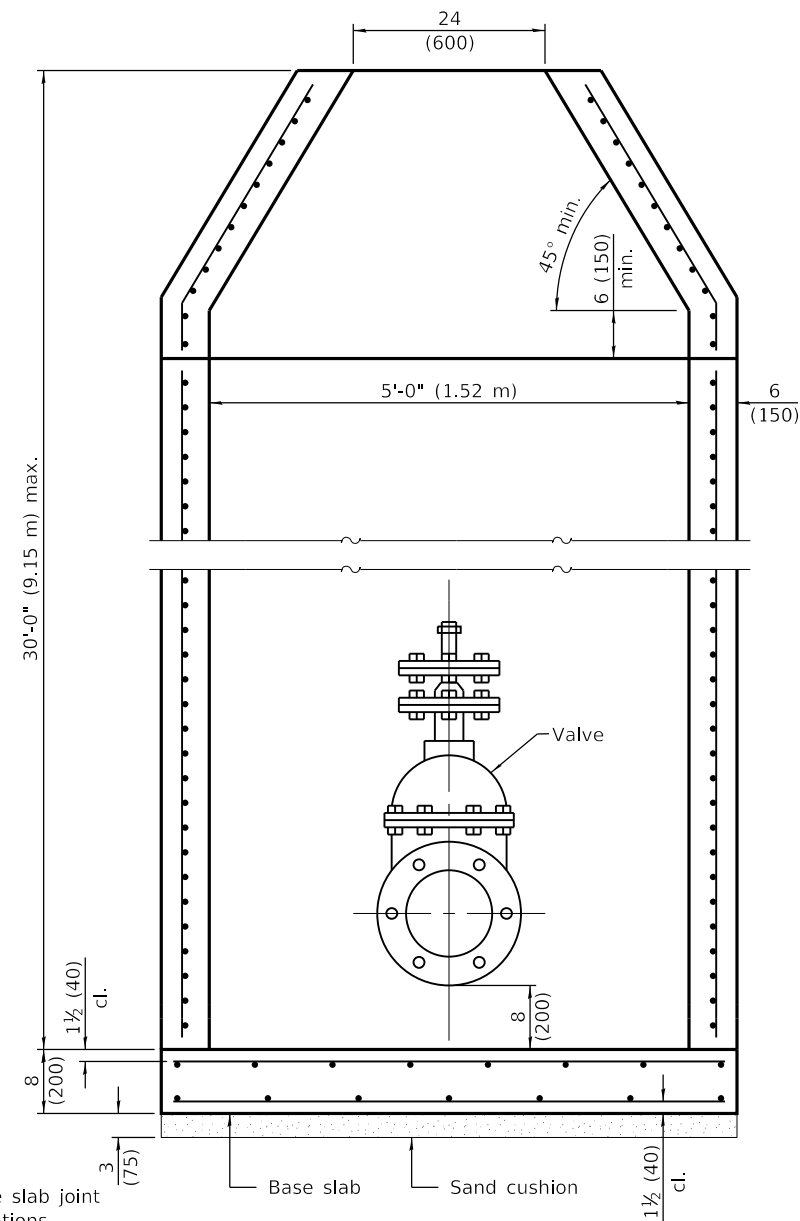

SECTION THRU VALVE VAULT
(With concentric conical top)

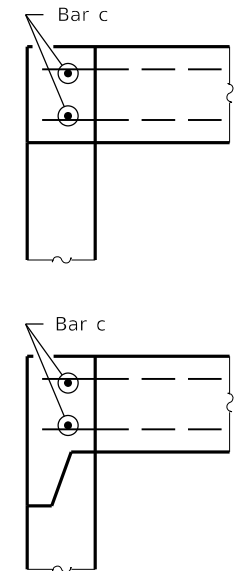

**FLAT SLAB TOP
JOINT CONFIGURATIONS**
(Shown at access hole)

GENERAL NOTES

Use this standard for water mains ≥ 10 (250).

The manufacturer shall ensure that all precast manhole sections are additionally reinforced where required to resist damage from handling, shipping and installation stresses.

Lifting holes shall be located in the sections as per the manufacturer's recommendations.

See Standard 602701 for details of manhole steps.

All dimensions are in inches (millimeters) unless otherwise noted.

Illinois Department of Transportation

PASSED January 1, 2021
Michael Bond
 ENGINEER OF POLICY AND PROCEDURES

APPROVED January 1, 2021
J. E. ...
 ENGINEER OF DESIGN AND ENVIRONMENT

ISSUED 1-1-18

DATE	REVISIONS
1-1-21	Revised lifting hole general note.
3-1-19	Moved wall reinforcement from inside face to middle.

PRECAST VALVE VAULT TYPE A
5' (1.52 m) DIAMETER

(Sheet 1 of 2)

STANDARD 602506-03

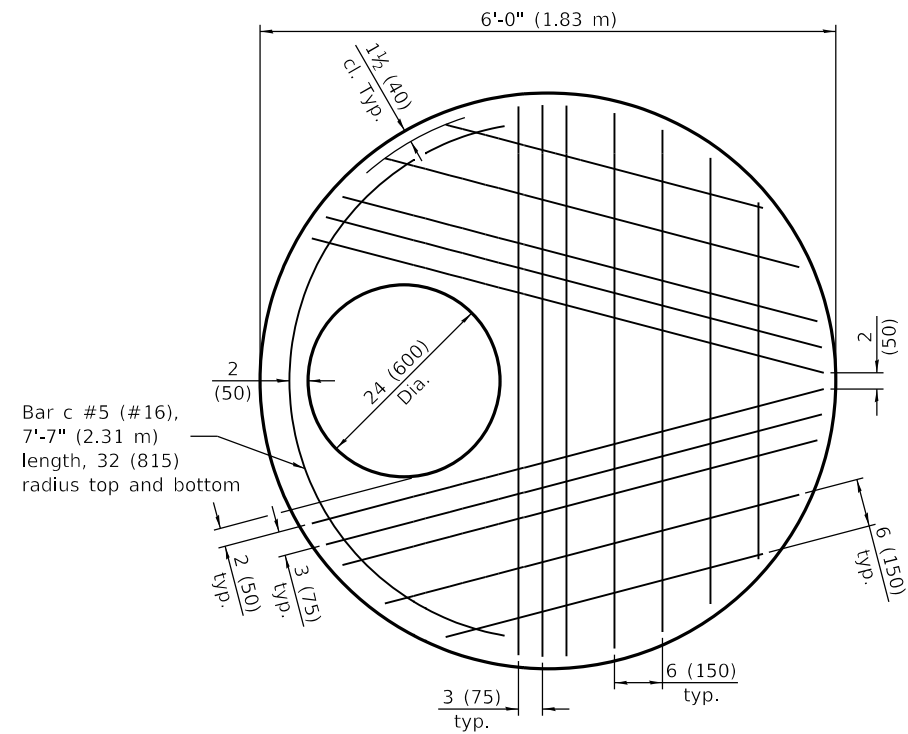

PLAN - FLAT SLAB TOP

(Showing layout of bottom reinforcement bars and c bars)

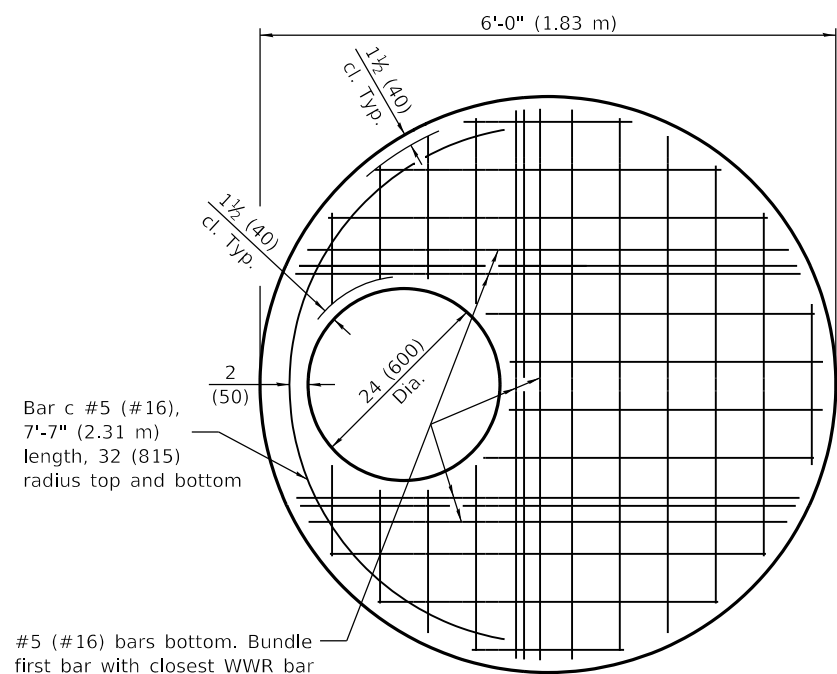

PLAN - FLAT SLAB TOP

(Showing layout of welded wire reinforcement and c bars)

FLAT SLAB TOP REINFORCEMENT

Location	WWR (each direction)		Rebar (each direction except as noted)		
	A _s (min.)	Spacing (max.)	A _s (min.)	Spacing (max.)	Bar Size
Top Mat	0.11 sq. in./ft. (233 sq. mm/m)	18 (450)	0.11 sq. in./ft. (233 sq. mm/m)	18 (450)	#3 or #4 (#10) (#13)
Bottom Mat	* 0.40 sq. in./ft. (847 sq. mm/m)	6 (150)	See plan view for rebar orientation and spacing and this table for bar size		#4 (#13)

* Only one layer of WWR permitted to avoid congestion.

WALL REINFORCEMENT

Orientation	WWR or Rebar	
	A _s (min.)	Spacing (max.)
Circumferential	0.15 sq. in./ft. (318 sq. mm/m)	6 (150)
Vertical	0.045 sq. in./ft. (95 sq. mm/m)	8 (200)

BASE SLAB REINFORCEMENT

Location	Total Height	WWR or Rebar (each direction)	
		A _s (min.)	Spacing (max.)
Top Mat	≤ 20 ft. (6.10 m)	0.24 sq. in./ft. (508 sq. mm/m)	10 (250)
	> 20 ft. (6.10 m)	0.28 sq. in./ft. (593 sq. mm/m)	8 (200)
Bottom Mat	All	0.11 sq. in./ft. (233 sq. mm/m)	18 (450)

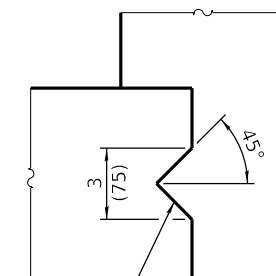
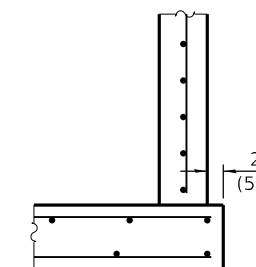
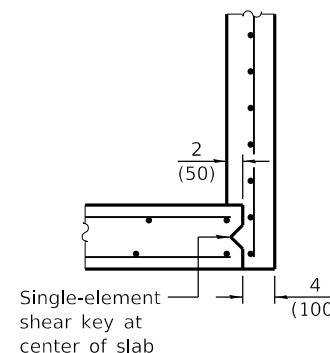
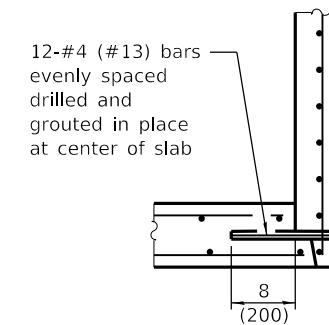
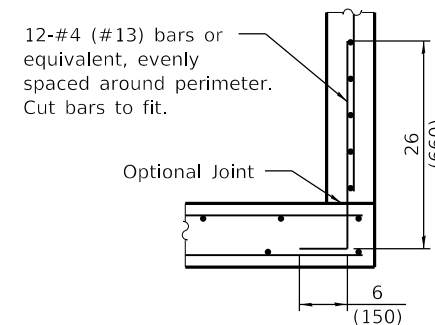
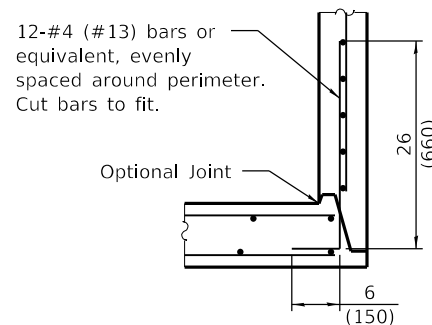

Single-element shear key at center of slab

SHEAR KEY GEOMETRY

(Reinforcement not shown for clarity)

BASE SLAB JOINT CONFIGURATIONS

PRECAST VALVE VAULT TYPE A
5' (1.52 m) DIAMETER

(Sheet 2 of 2)

STANDARD 602506-03

Illinois Department of Transportation

PASSED January 1, 2021

 ENGINEER OF POLICY AND PROCEDURES

APPROVED January 1, 2021

 ENGINEER OF DESIGN AND ENVIRONMENT

ISSUED 1-1-18

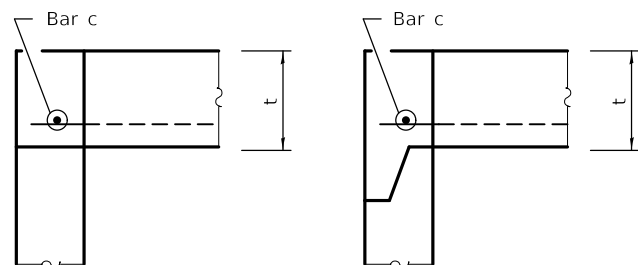

**FLAT SLAB TOP JOINT CONFIGURATIONS
FOR D = 36 (900) AND D = 4'-0" (1.22 m)**

(Shown at access hole)

See Top Slab Joint Configurations for D=36 (900) and D=4'-0" (1.22 m)

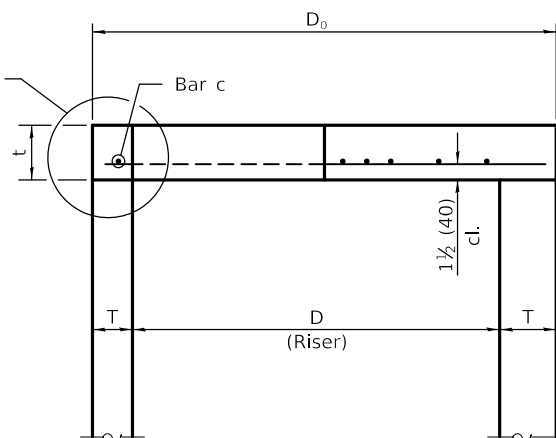

**SECTION THRU FLAT SLAB TOP
FOR D = 36 (900) AND D = 4'-0" (1.22 m)**

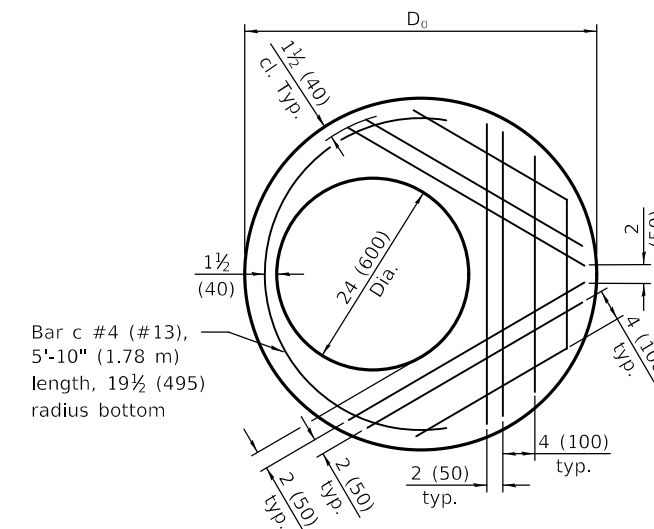

PLAN - FLAT SLAB TOP FOR D = 36 (900)

(Showing layout of reinforcement bars and c bars)

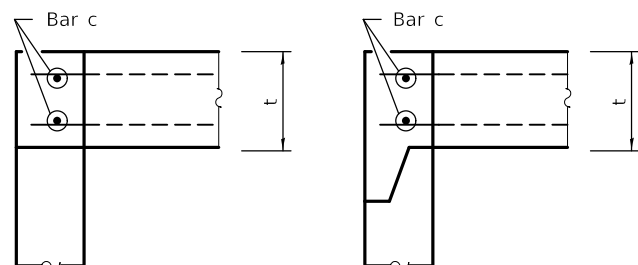

**FLAT SLAB TOP JOINT CONFIGURATIONS
D = 5'-0" (1.52 m)**

(Shown at access hole)

See Top Slab Joint Configurations for D=5'-0" (1.52 m)

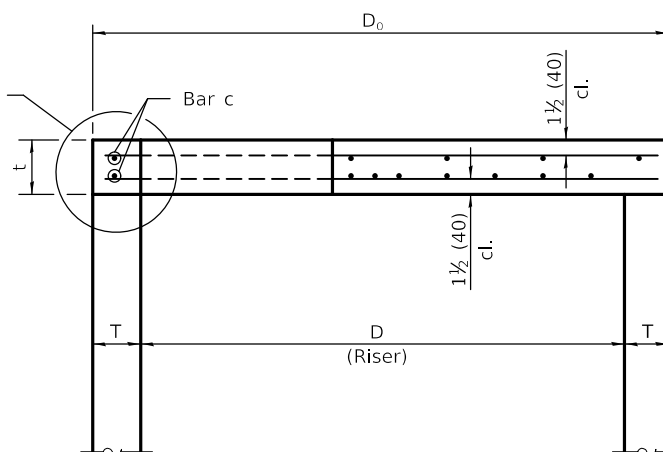

**SECTION THRU FLAT SLAB TOP
FOR D = 5'-0" (1.52 m)**

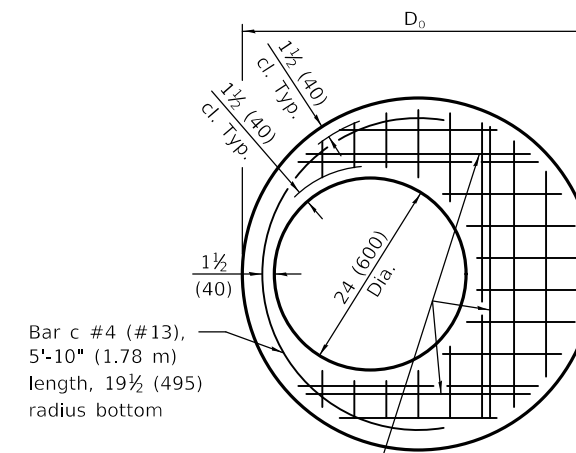

PLAN - FLAT SLAB TOP FOR D = 36 (900)

(Showing layout of welded wire reinforcement and c bars)

TABLE

D	T	D _o (min.)	t
36 (900)	See applicable Standards	D + 2T	6 (150)
4'-0" (1.2 m)			6 (150)
5'-0" (1.5 m)			8 (200)

GENERAL NOTES

The flat slab top may be used in lieu of the tapered tops shown on Standards 602001, 602016, or 602306 at the option of the Contractor or when field conditions prohibit the use of tapered tops.

Lifting holes shall be located in the sections as per the manufacturer's recommendations.

All dimensions are in inches (millimeters) unless otherwise shown.

DATE	REVISIONS
1-1-19	Expanded / refined reinforcement options.
1-1-18	Revised for compliance with LRFD.

**PRECAST REINFORCED
CONCRETE FLAT SLAB TOP**

(Sheet 1 of 2)

STANDARD 602601-06

Illinois Department of Transportation

PASSED January 1, 2019
Michael Bond
ENGINEER OF POLICY AND PROCEDURES

APPROVED January 1, 2019
Joe E. C...
ENGINEER OF DESIGN AND ENVIRONMENT

ISSUED 1-1-97

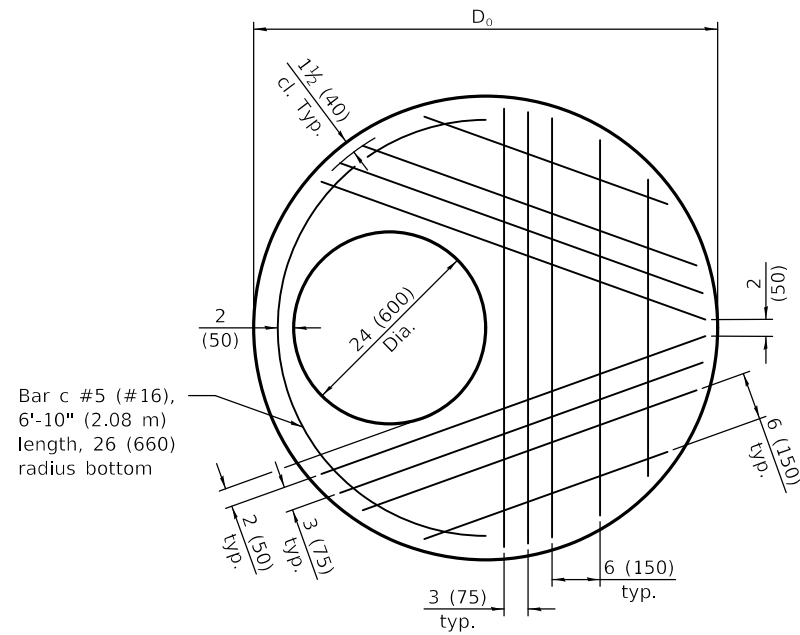

PLAN - FLAT SLAB TOP FOR D = 4'-0" (1.22 m)
(Showing layout of reinforcement bars and c bars)

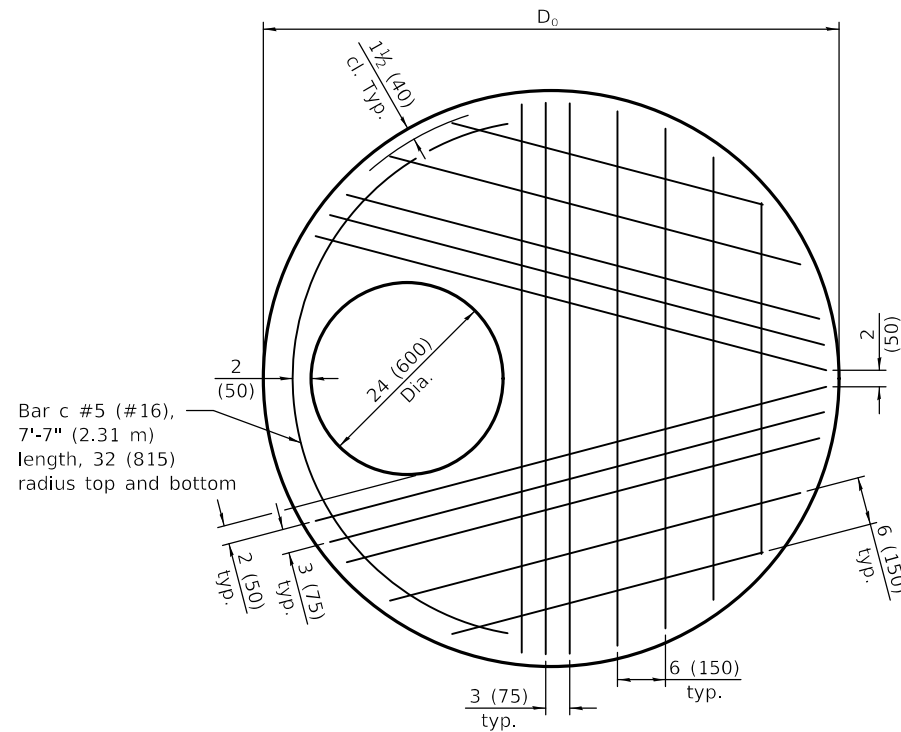

PLAN - FLAT SLAB TOP FOR D = 5'-0" (1.52 m)
(Showing layout of bottom reinforcement bars and c bars)

FLAT SLAB TOP REINFORCEMENT FOR D = 36 (900)

Location	WWR (each direction)		Rebar		
	A _s (min.)	Spacing (max.)	A _s (min.)	Spacing (max.)	Bar Size
Bottom Mat	* 0.60 sq. in./ft. (1270 sq. mm/m)	6 (150)	See plan view for rebar orientation and spacing and this table for bar size		#4 (#13)

FLAT SLAB TOP REINFORCEMENT FOR D = 4'-0" (1.22 m)

Location	WWR (each direction)		Rebar		
	A _s (min.)	Spacing (max.)	A _s (min.)	Spacing (max.)	Bar Size
Bottom Mat	* 0.62 sq. in./ft. (1312 sq. mm/m)	6 (150)	See plan view for rebar orientation and spacing and this table for bar size		#5 (#16)

FLAT SLAB TOP REINFORCEMENT FOR D = 5'-0" (1.52 m)

Location	WWR (each direction)		Rebar (each direction except as noted)		
	A _s (min.)	Spacing (max.)	A _s (min.)	Spacing (max.)	Bar Size
Top Mat	0.11 sq. in./ft. (233 sq. mm/m)	18 (450)	0.11 sq. in./ft. (233 sq. mm/m)	18 (450)	#3 or #4 (#10) (#13)
Bottom Mat	* 0.40 sq. in./ft. (847 sq. mm/m)	6 (150)	See plan view for rebar orientation and spacing and this table for bar size		#4 (#13)

* Only one layer of WWR permitted to avoid congestion.

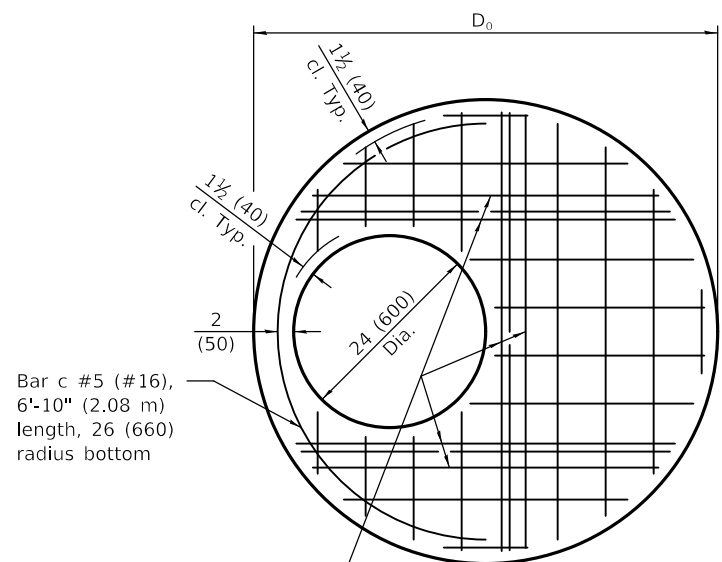

PLAN - FLAT SLAB TOP FOR D = 4'-0" (1.22 m)
(Showing layout of welded wire reinforcement and c bars)

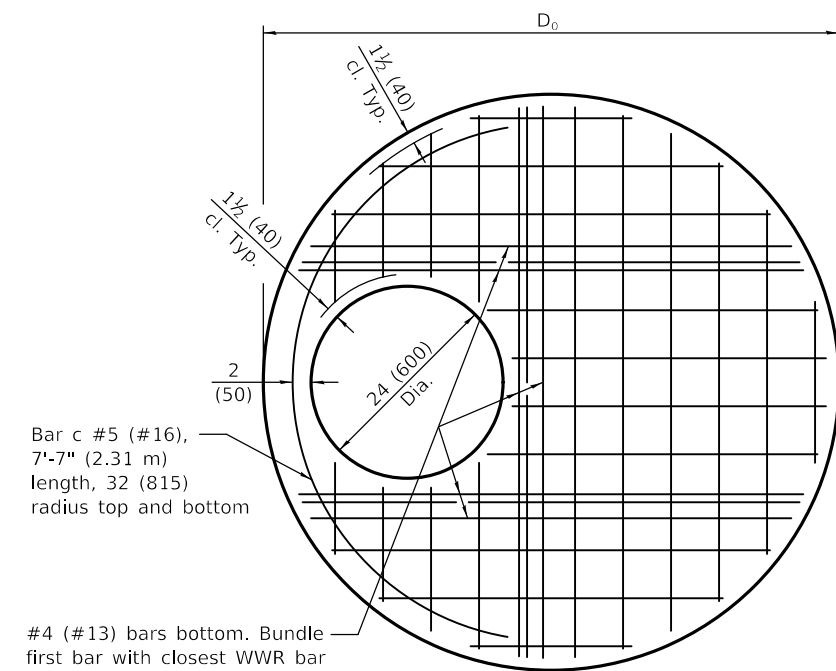

PLAN - FLAT SLAB TOP FOR D = 5'-0" (1.52 m)
(Showing layout of welded wire reinforcement and c bars)

#5 (#16) bars bottom. Bundle first bar with closest WWR bar to the opening and place second bar ±3 (75) away.

#4 (#13) bars bottom. Bundle first bar with closest WWR bar to the opening and place second bar ±3 (75) away.

Illinois Department of Transportation

PASSED January 1, 2019

 ENGINEER OF POLICY AND PROCEDURES

APPROVED January 1, 2019

 ENGINEER OF DESIGN AND ENVIRONMENT

ISSUED 1-1-97

**PRECAST REINFORCED
CONCRETE FLAT SLAB TOP**

(Sheet 2 of 2)

STANDARD 602601-06

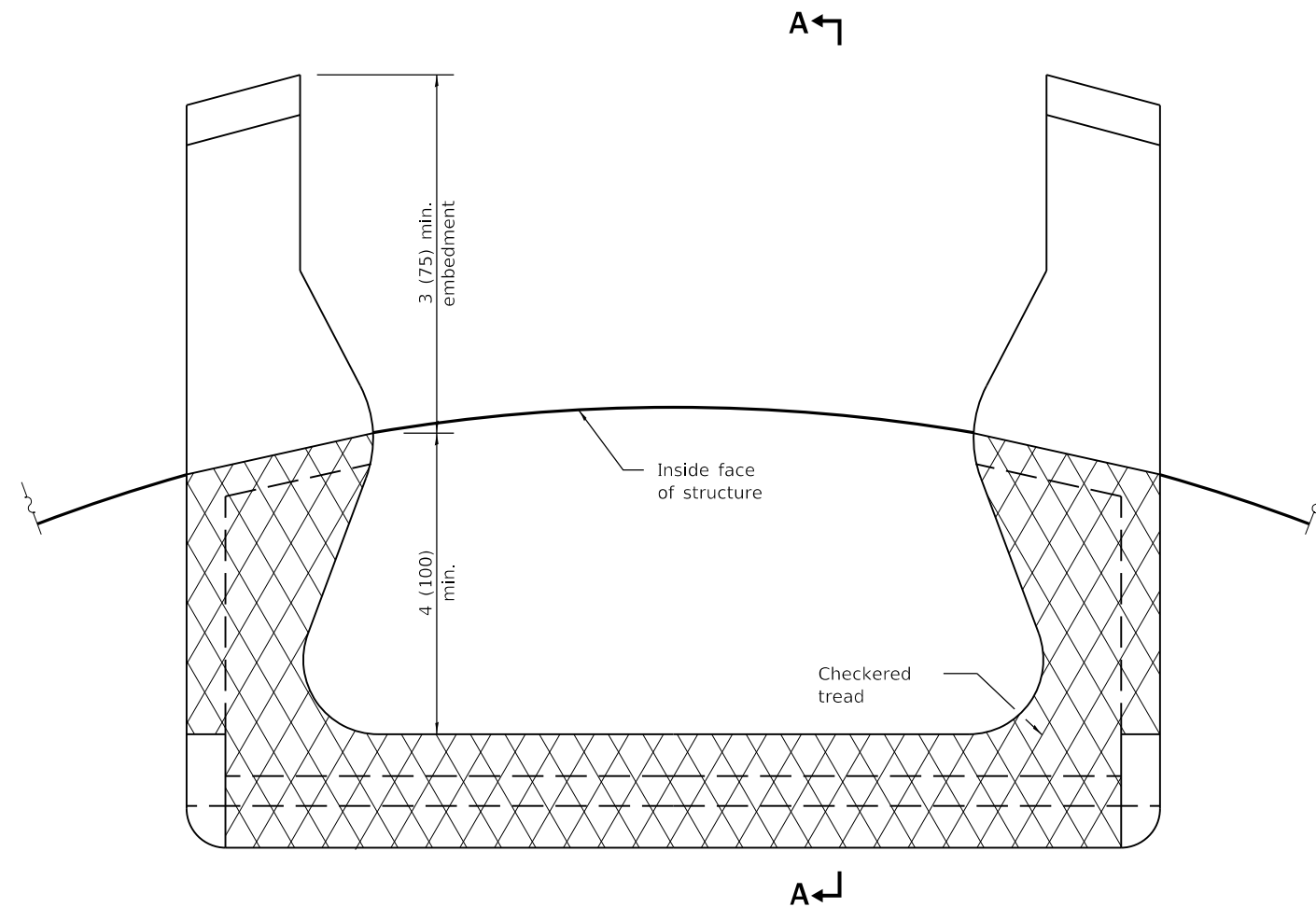

PLAN VIEW

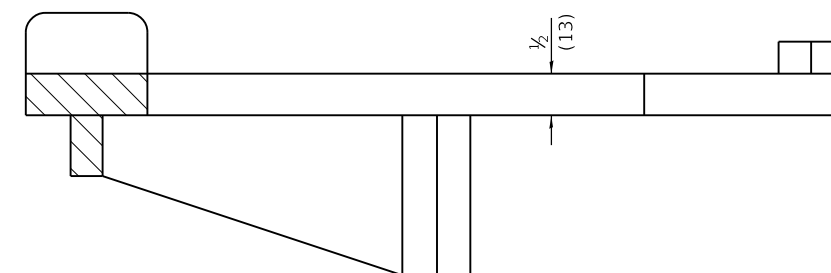

SECTION A-A

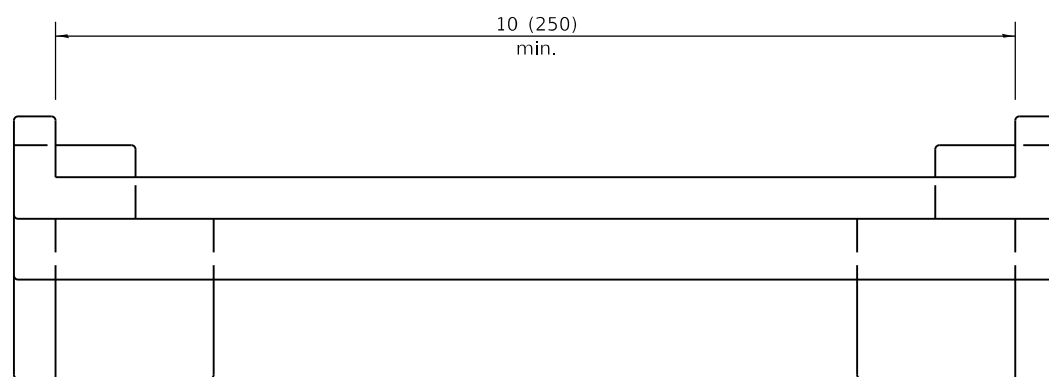

ELEVATION VIEW

All dimensions are in inches (millimeters) unless otherwise shown.

 Illinois Department of Transportation
 PASSED January 1, 2009
[Signature]
 ENGINEER OF POLICY AND PROCEDURES
 APPROVED January 1, 2009
[Signature]
 ENGINEER OF DESIGN AND ENVIRONMENT

ISSUED 1-1-97

DATE	REVISIONS
1-1-09	Switched units to English (metric).
4-1-06	Revised title, drawings, and added plastic steps on sheet 2.

MANHOLE STEPS

(Sheet 1 of 2)

STANDARD 602701-02

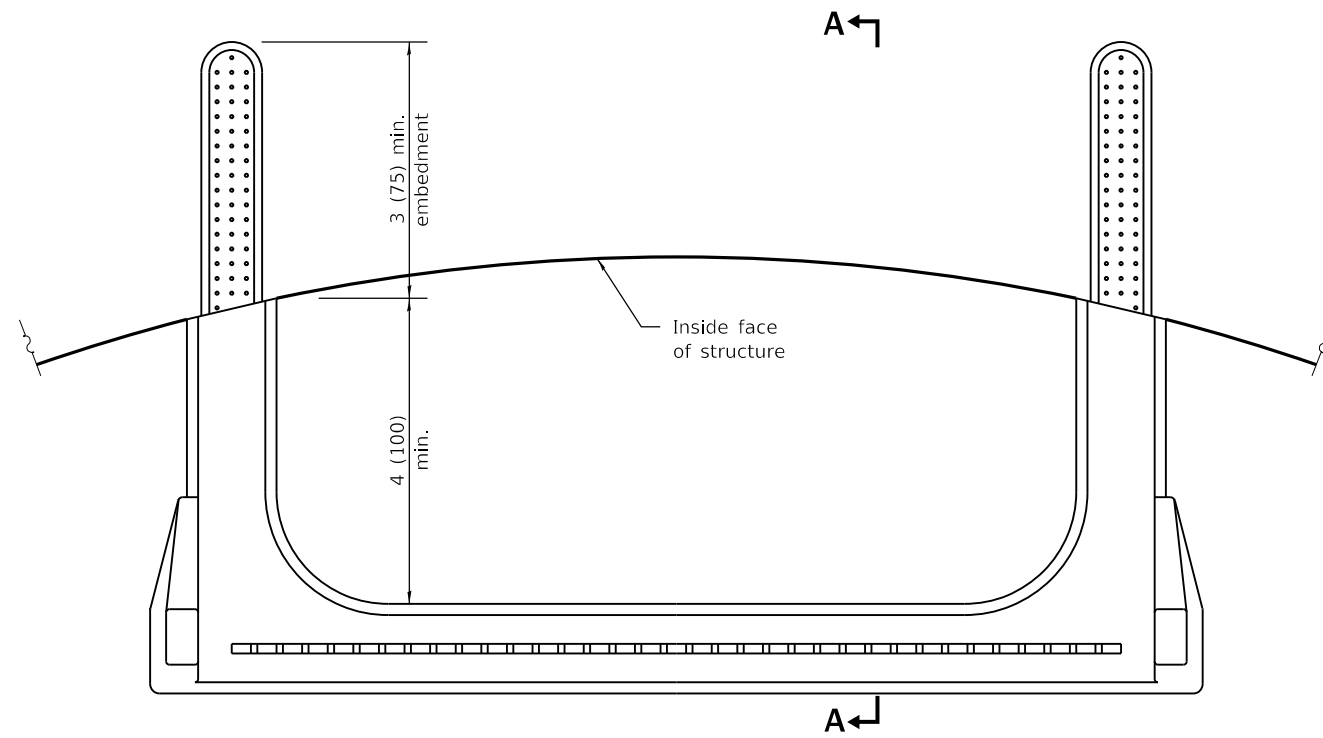

PLAN VIEW

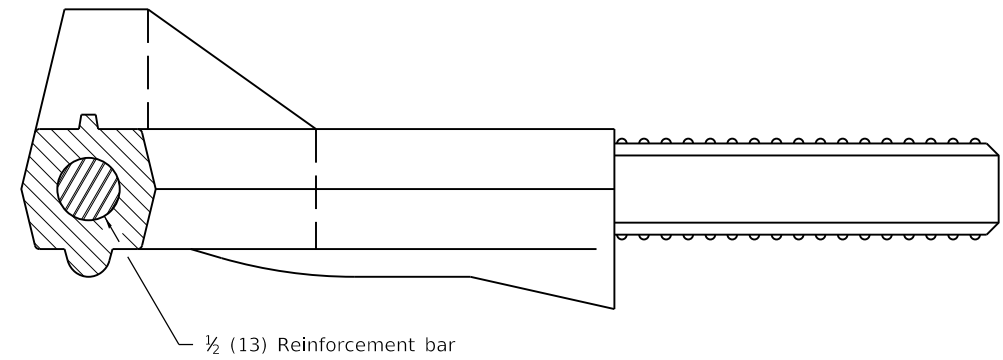

SECTION A-A

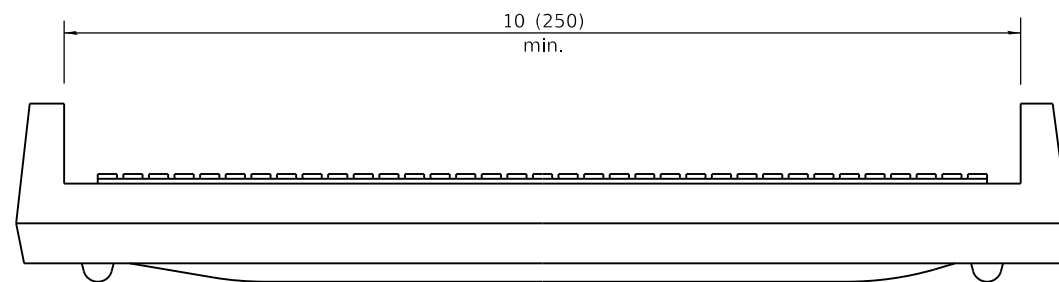

ELEVATION VIEW

Illinois Department of Transportation

PASSED January 1, 2009

ENGINEER OF POLICY AND PROCEDURES

APPROVED January 1, 2009

ENGINEER OF DESIGN AND ENVIRONMENT

ISSUED 1-1-97

MANHOLE STEPS

(Sheet 2 of 2)

STANDARD 602701-02

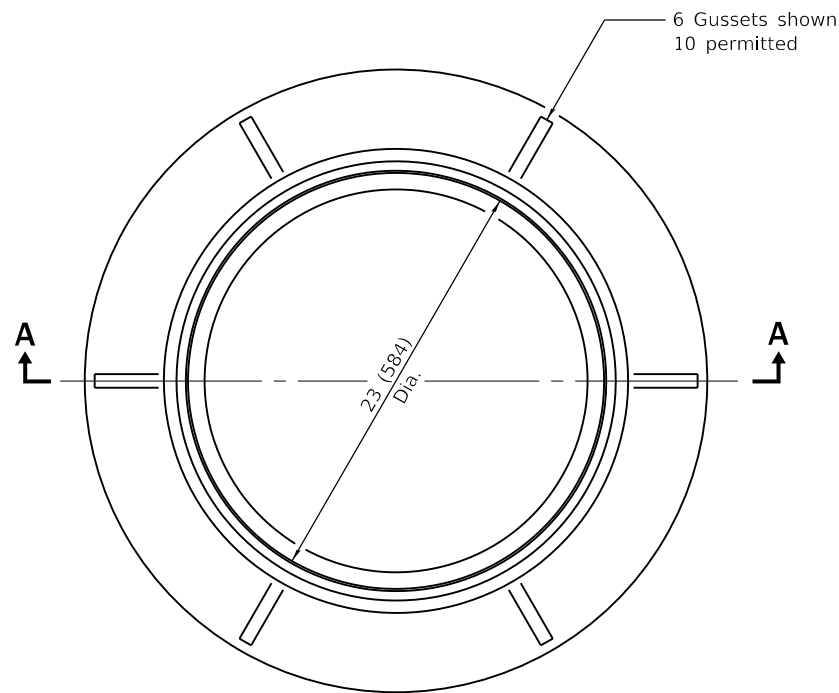

CAST FRAME

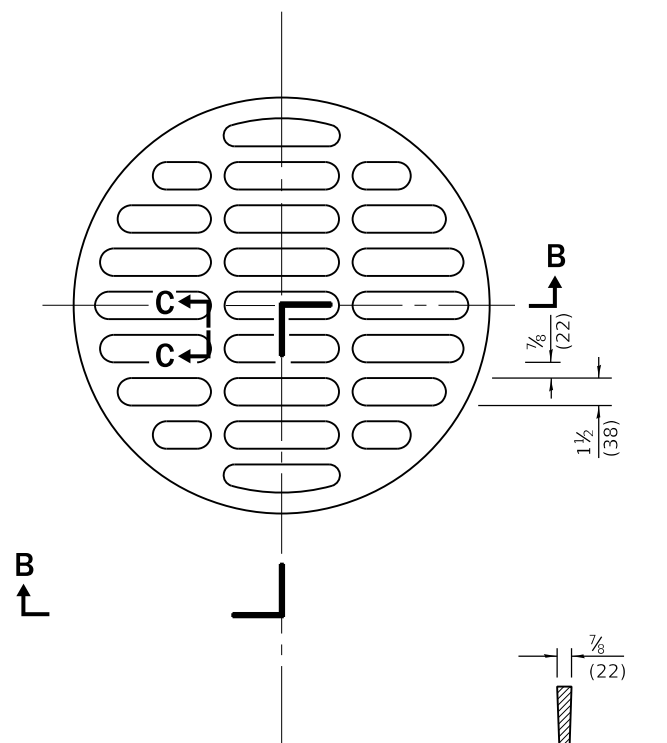

SECTION C-C

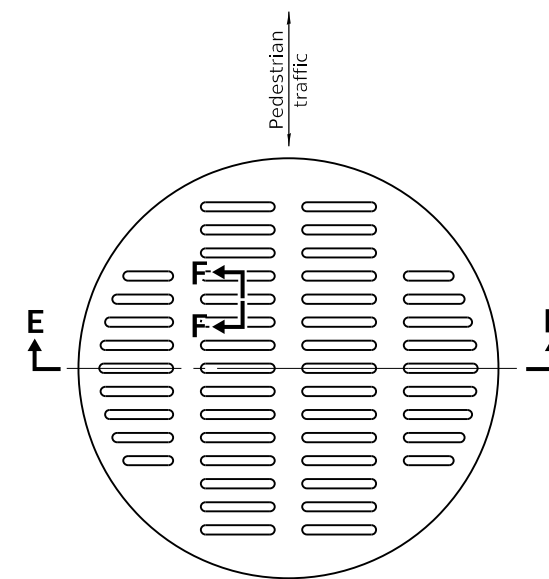

SECTION F-F

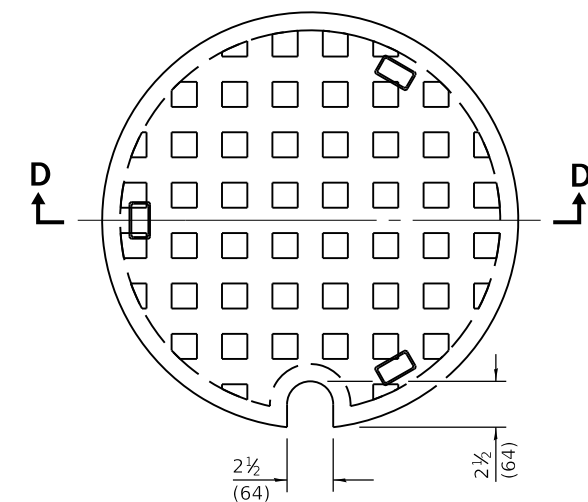

SECTION D-D

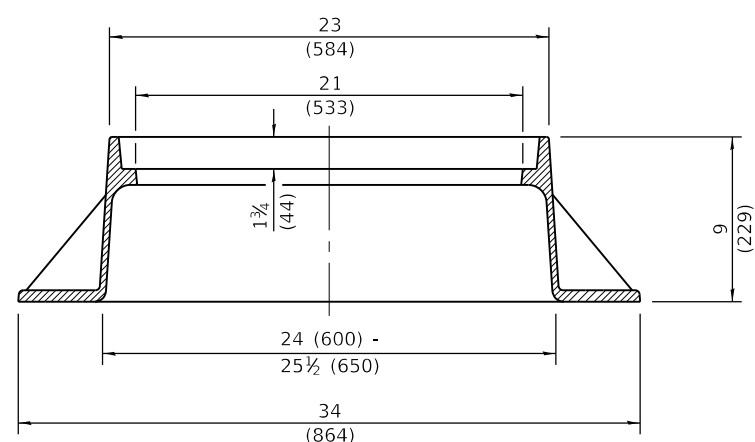

SECTION A-A

Gray Iron

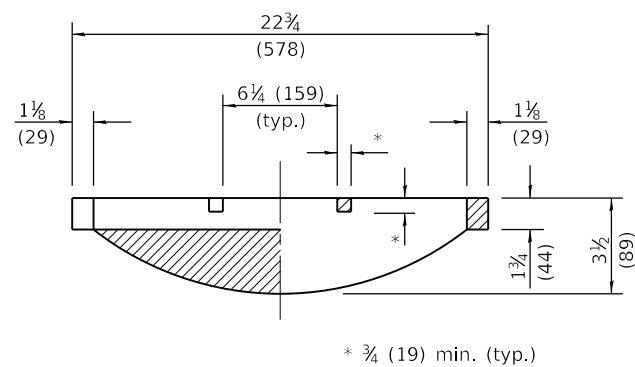

SECTION B-B

CAST OPEN LID

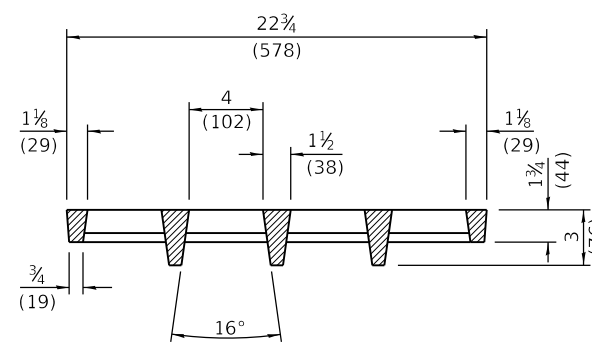

SECTION E-E

**ADA COMPLIANT
CAST OPEN LID**

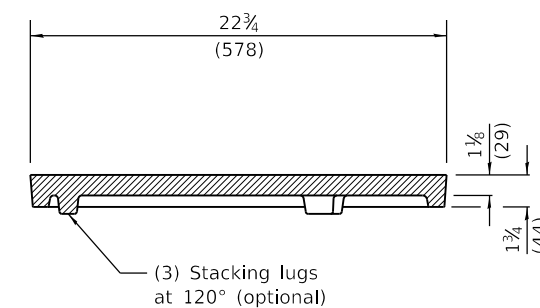

CAST CLOSED LID

Gray Iron Lid

All dimensions are in inches (millimeters) unless otherwise shown.

Illinois Department of Transportation

PASSED January 1, 2020
Michael Bond
 ENGINEER OF POLICY AND PROCEDURES

APPROVED January 1, 2020
J. S. E. E.
 ENGINEER OF DESIGN AND ENVIRONMENT

ISSUED 1-1-97

DATE	REVISIONS
1-1-20	Revised dimension in Section B-B of cast open lid.
1-1-15	Revised dimensioning of frame. Added ADA compliant open lid.
1-1-09	Switched units to English (metric).

**FRAME AND LIDS
TYPE 1**

STANDARD 604001-05

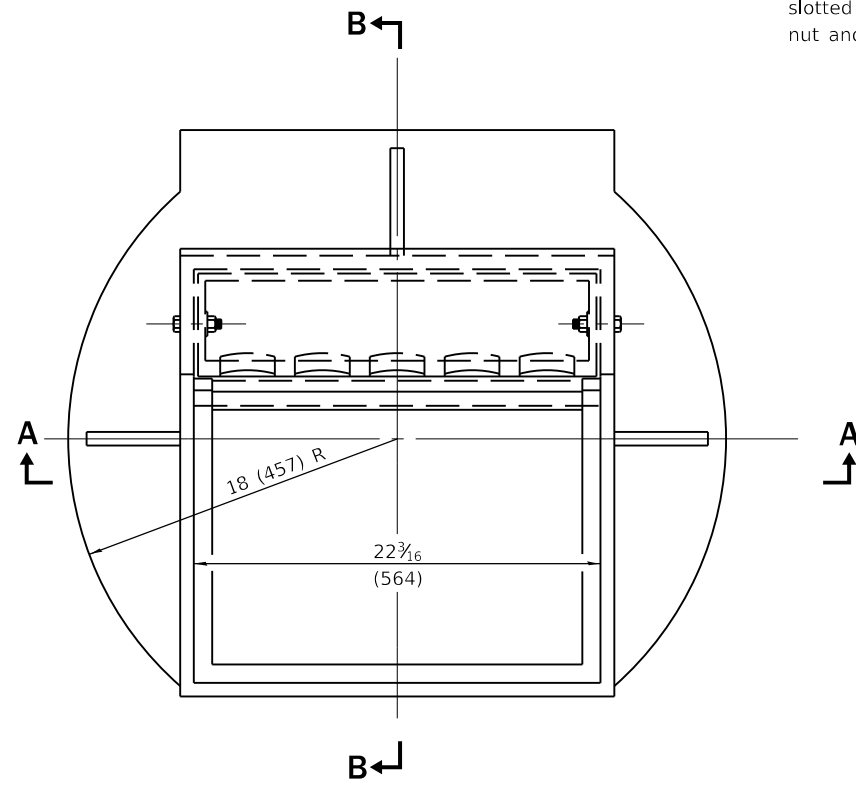

CAST FRAME

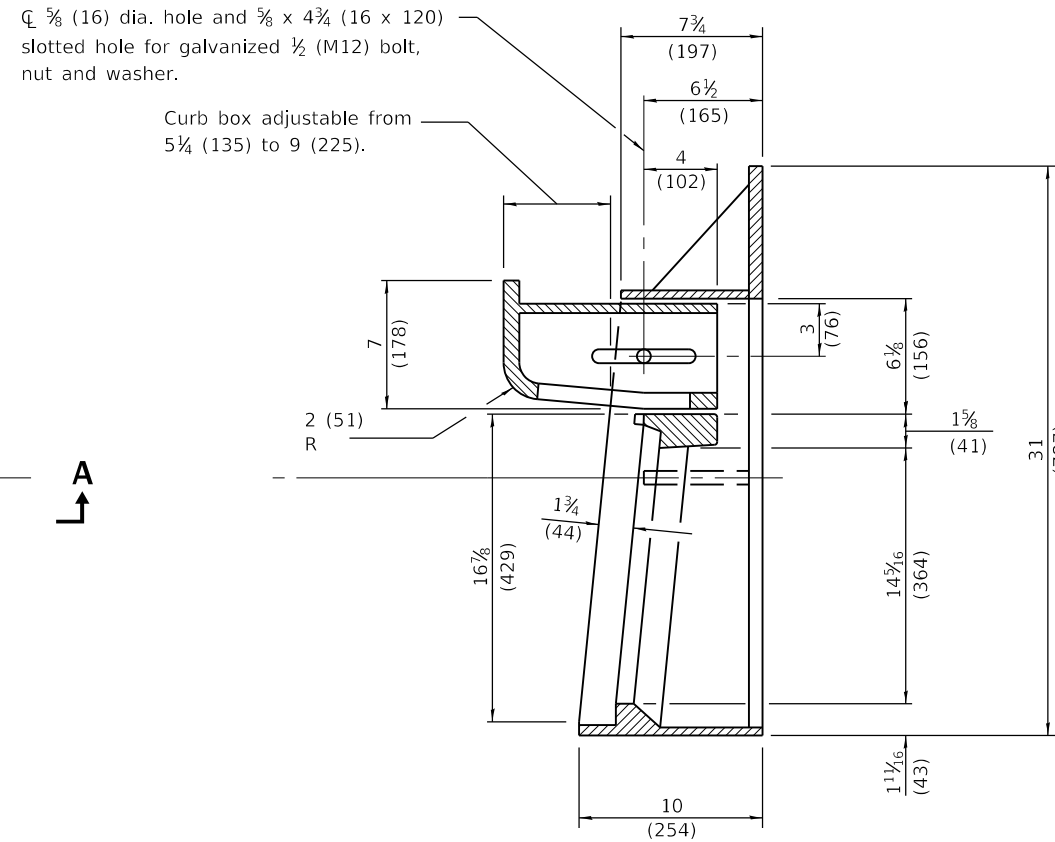

SECTION B-B

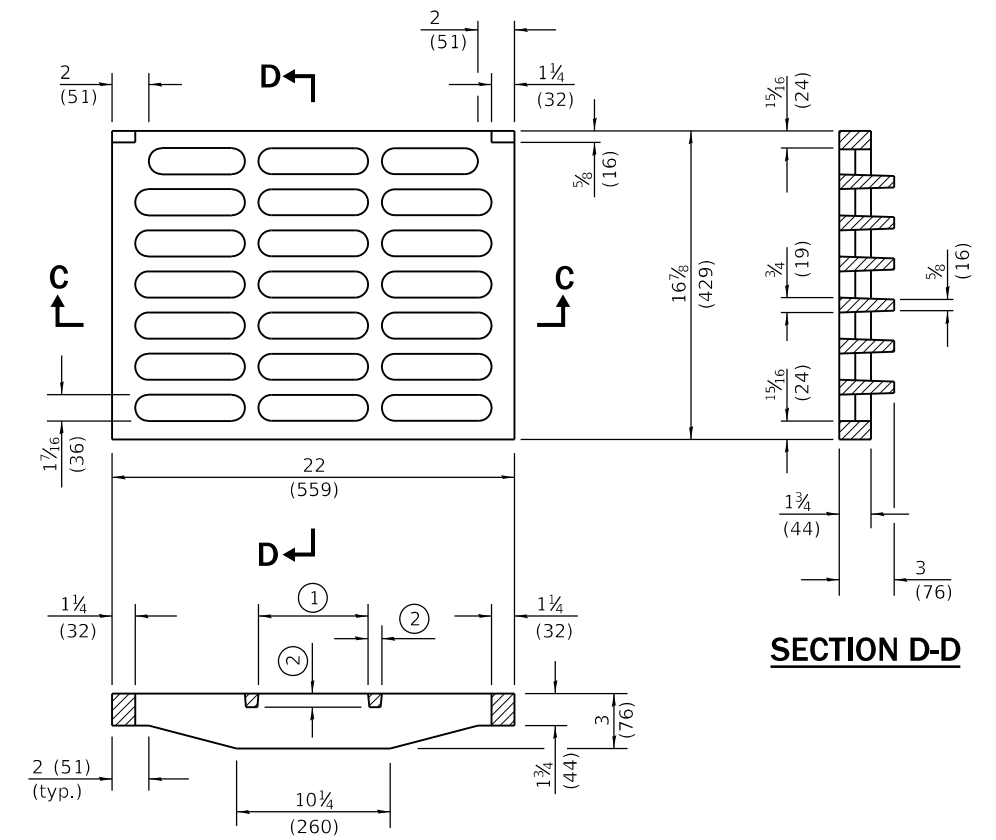

SECTION C-C

- ① = 6 (152) typ.
- ② = $\frac{3}{4}$ (19) typ.

CAST GRATE

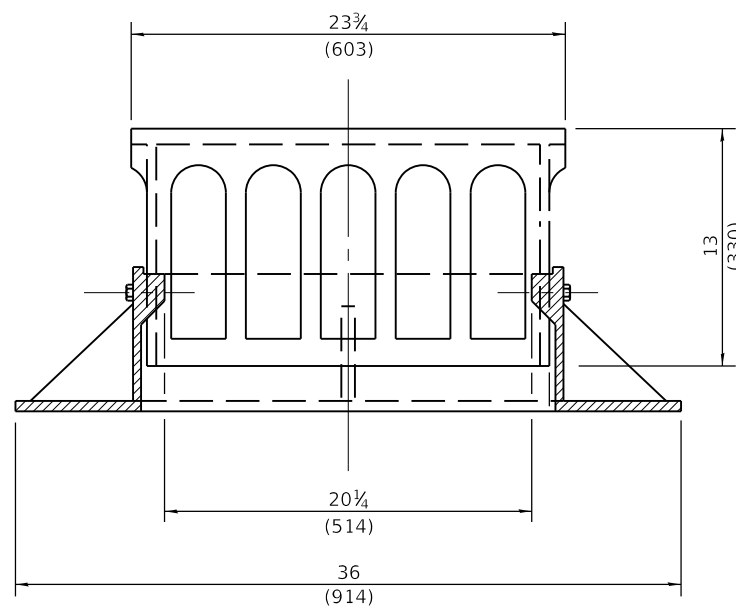

SECTION A-A

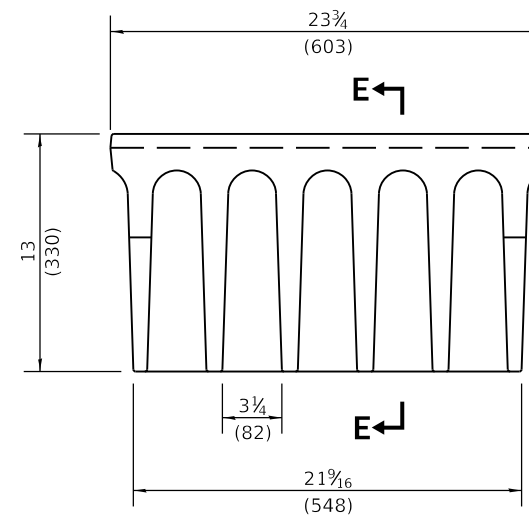

ALTERNATE CURB BOX

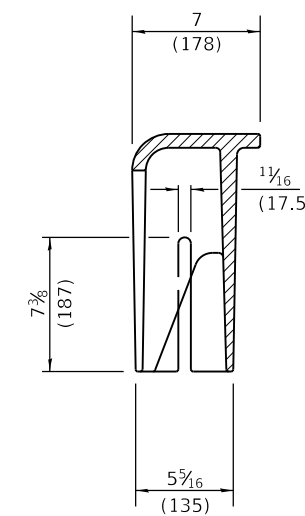

SECTION E-E

All dimensions are in inches (millimeters) unless otherwise shown.

Illinois Department of Transportation
 PASSED January 1, 2015
Michael Beard
 ENGINEER OF POLICY AND PROCEDURES
 APPROVED January 1, 2015
[Signature]
 ENGINEER OF DESIGN AND ENVIRONMENT

ISSUED 1-1-97

DATE	REVISIONS
1-1-15	Revised dimenstions of frame and alternate curb box.
1-1-09	Switched units to English (metric).

**FRAME AND GRATE
TYPE 3**

STANDARD 604006-05

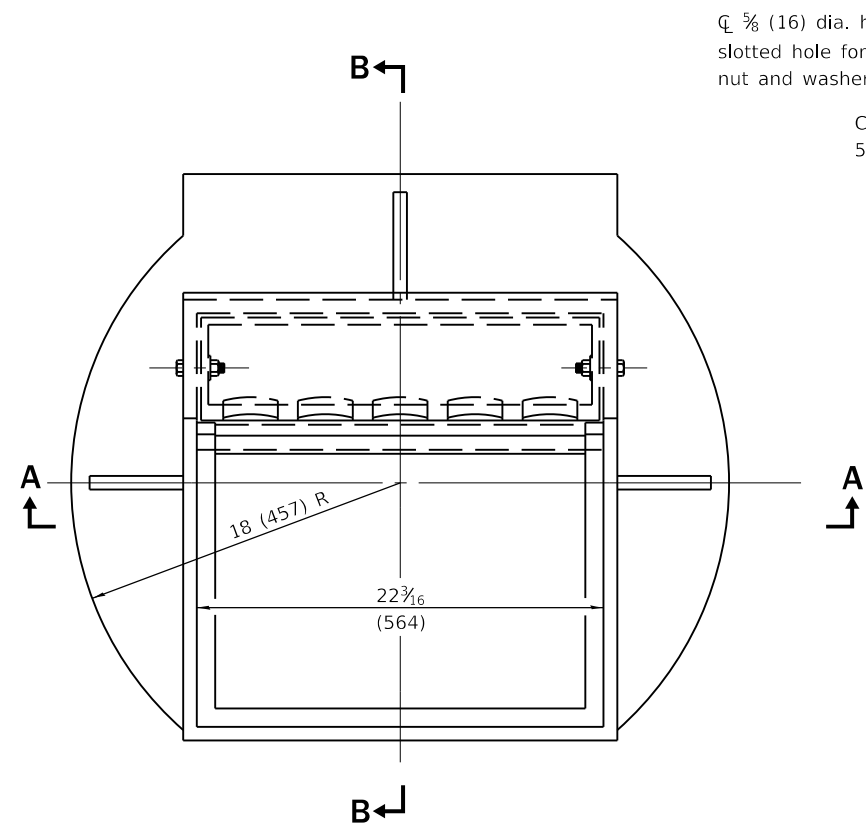

CAST FRAME

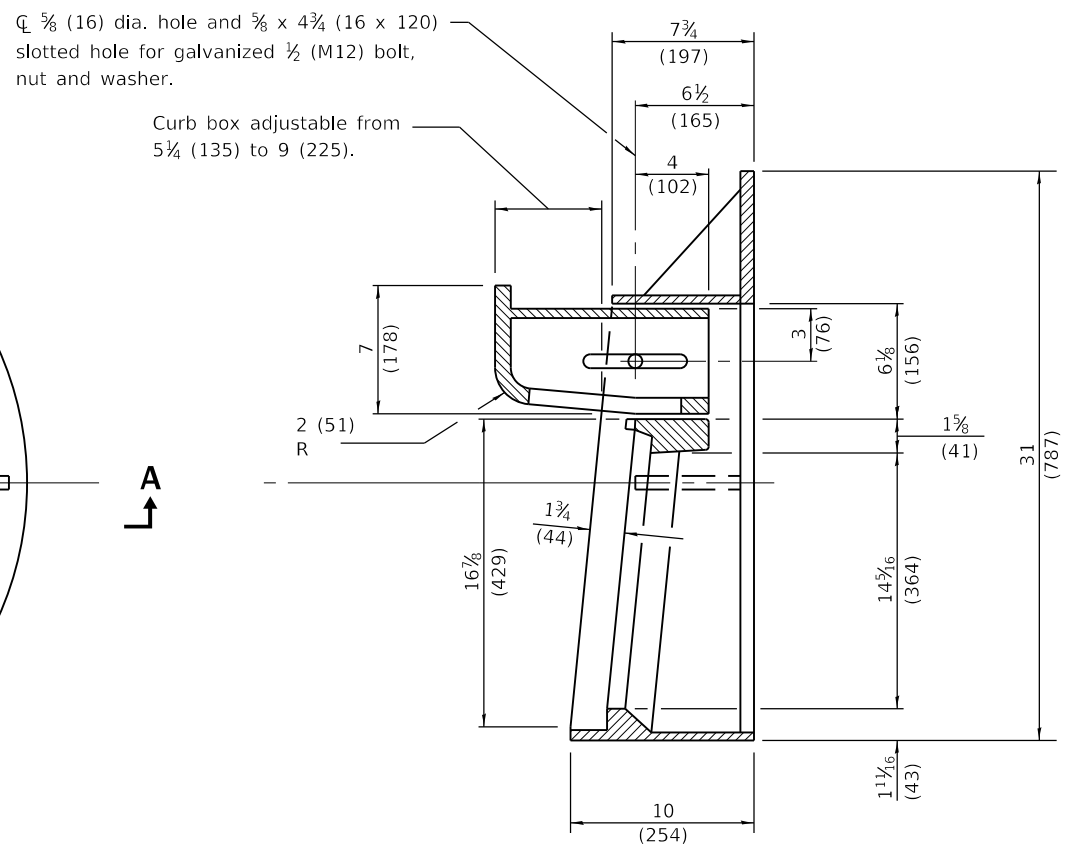

SECTION B-B

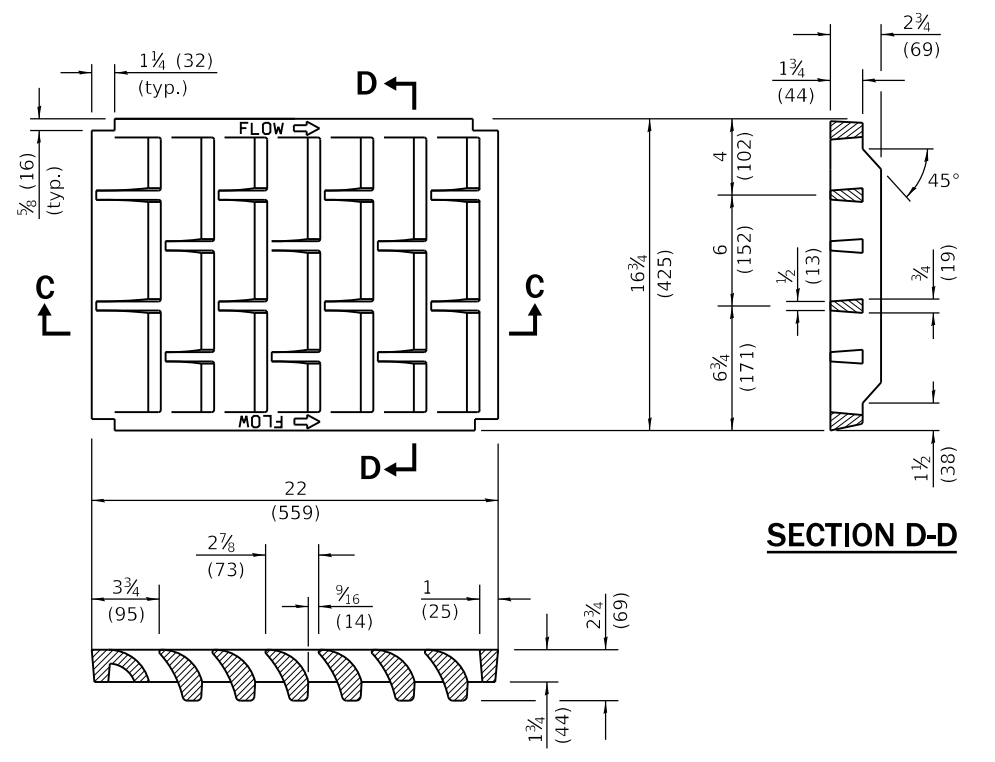

SECTION C-C

SECTION D-D

CAST GRATE

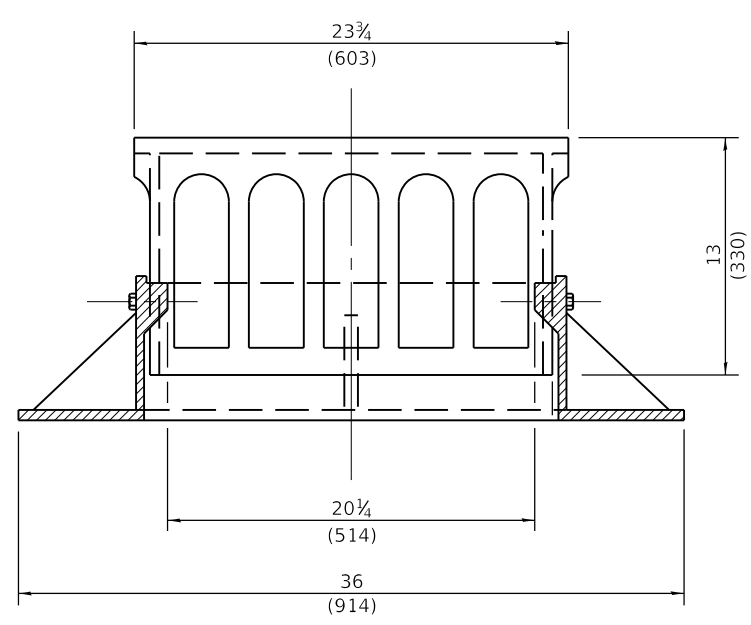

SECTION A-A

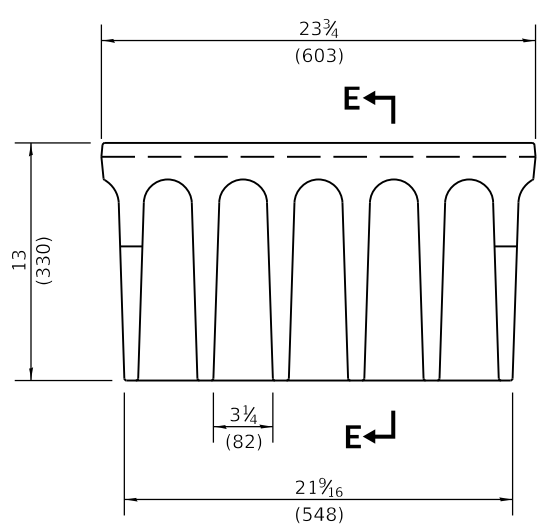

ALTERNATE CURB BOX

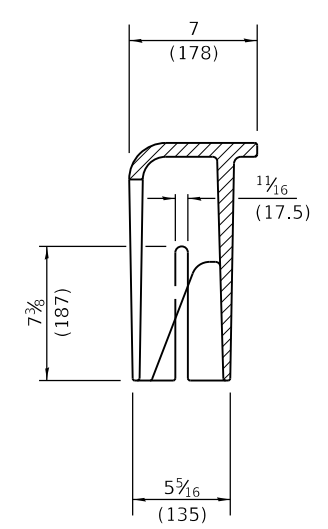

SECTION E-E

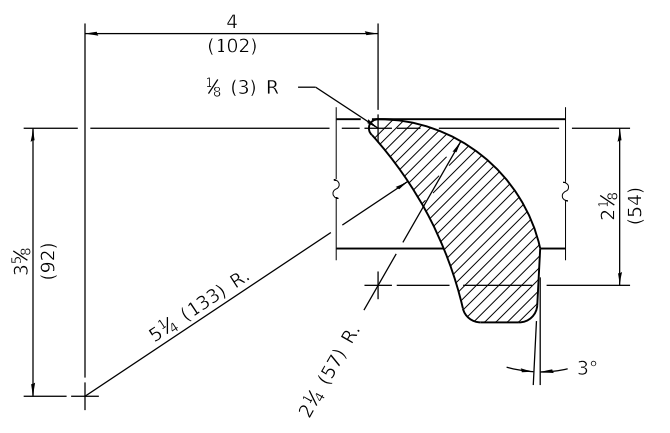

VANE DETAIL

All dimensions are in inches (millimeters) unless otherwise shown.

Illinois Department of Transportation

PASSED January 1, 2015
Michael Beard
 ENGINEER OF POLICY AND PROCEDURES

APPROVED January 1, 2015
[Signature]
 ENGINEER OF DESIGN AND ENVIRONMENT

ISSUED 1-1-97

DATE	REVISIONS
1-1-15	Revised dimensions of frame and alternate curb box.
1-1-09	Switched units to English (metric).

**FRAME AND GRATE
TYPE 3V**

STANDARD 604011-05

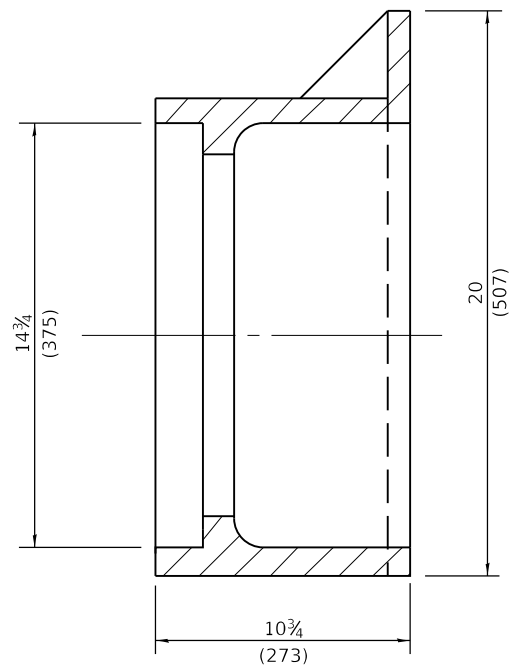
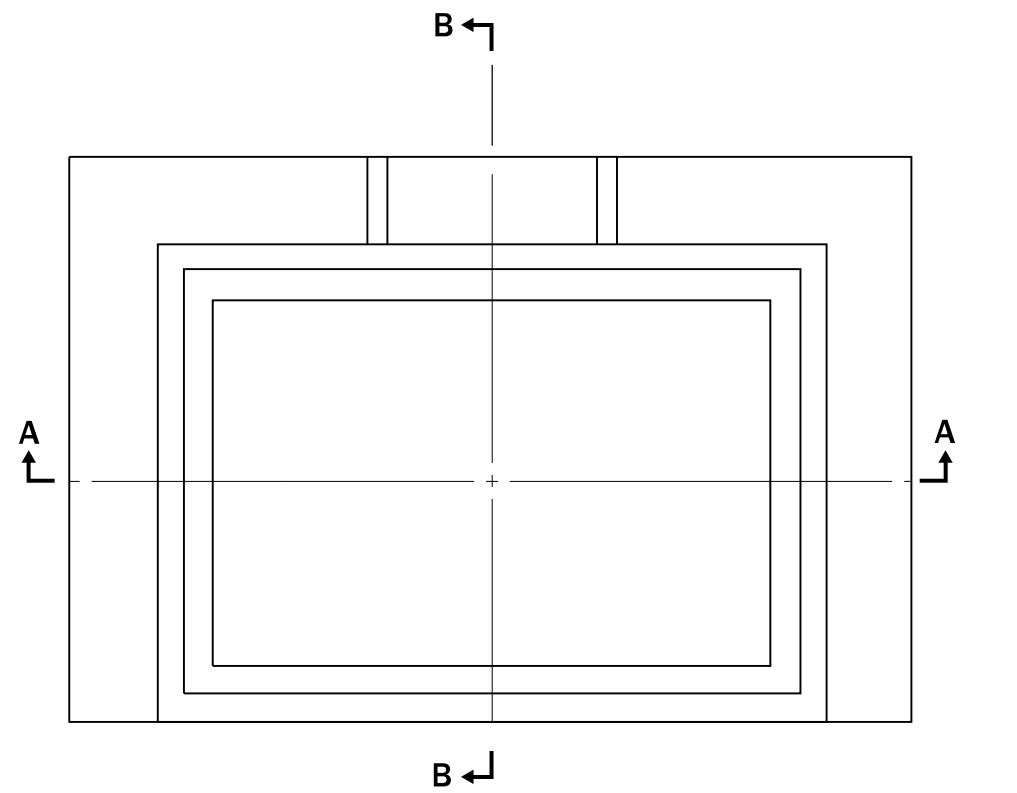

SECTION B-B

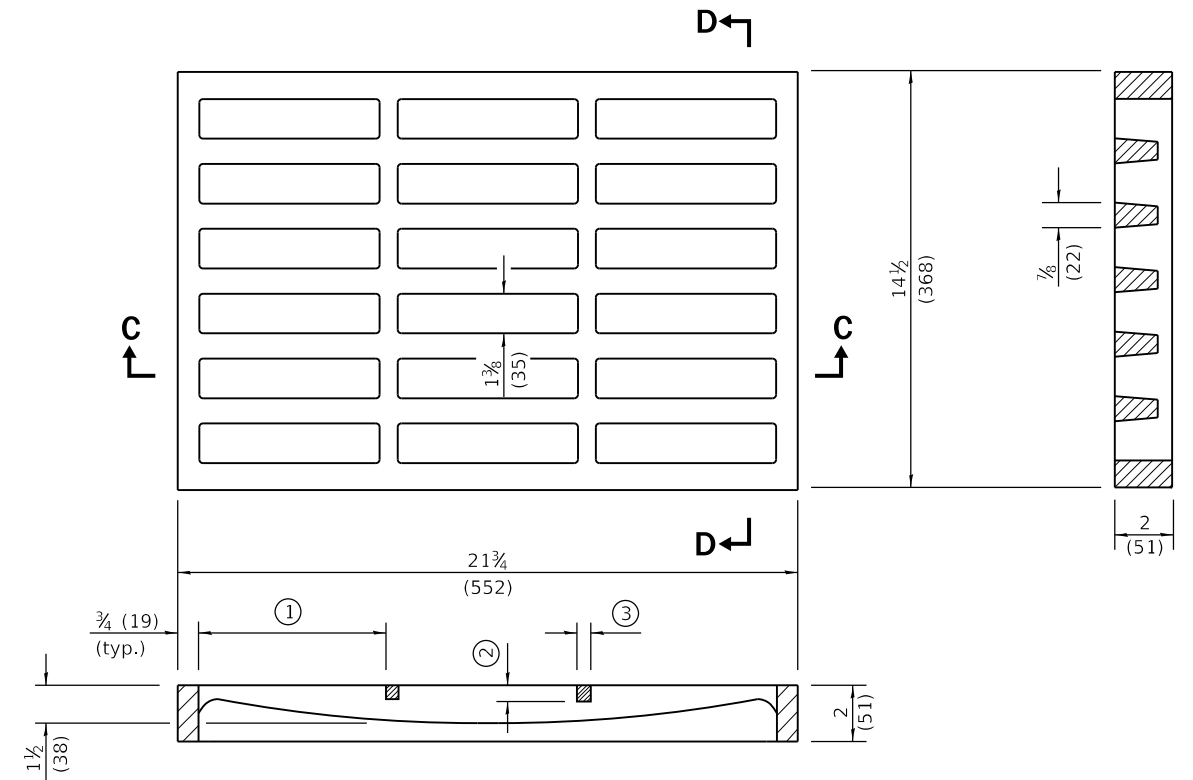

SECTION C-C

SECTION D-D

- ① = 6 1/4 (159) (typ.)
- ② = 3/4 (19) (typ.)
- ③ = 5/8 (16) (typ.)

CAST GRATE

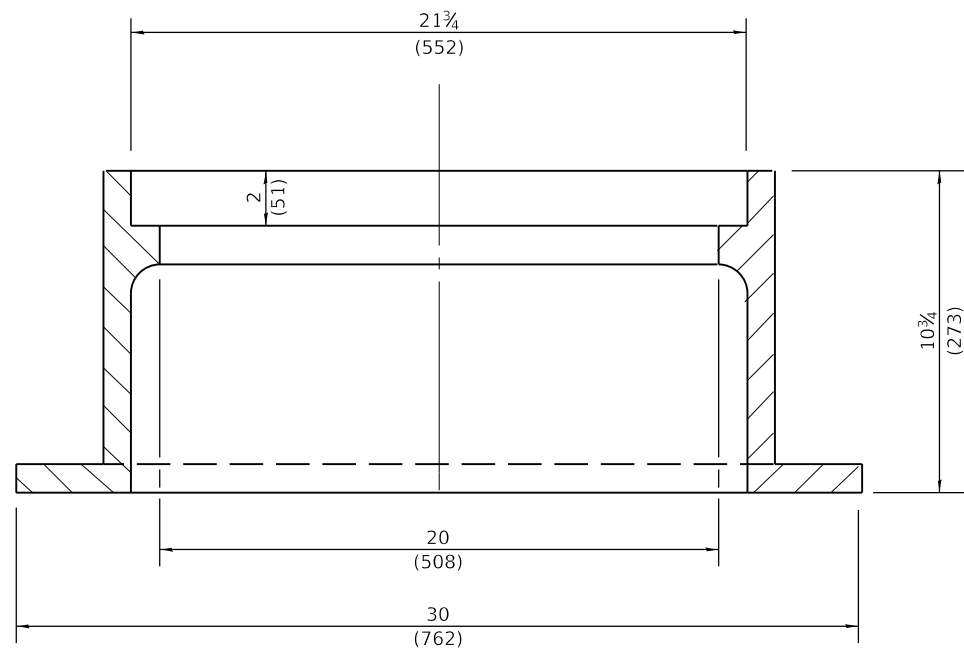

SECTION A-A

CAST FRAME

All dimensions are in inches (millimeters) unless otherwise shown.

Illinois Department of Transportation

PASSED April 1, 2016

Michael Beard
ENGINEER OF POLICY AND PROCEDURES

APPROVED April 1, 2016

[Signature]
ENGINEER OF DESIGN AND ENVIRONMENT

ISSUED 1-1-97

DATE	REVISIONS
4-1-16	Corrected dimension on SECTION A-A.
1-1-15	Revised dimensions of frame and grate.

**FRAME AND GRATE
TYPE 4**

STANDARD 604016-04

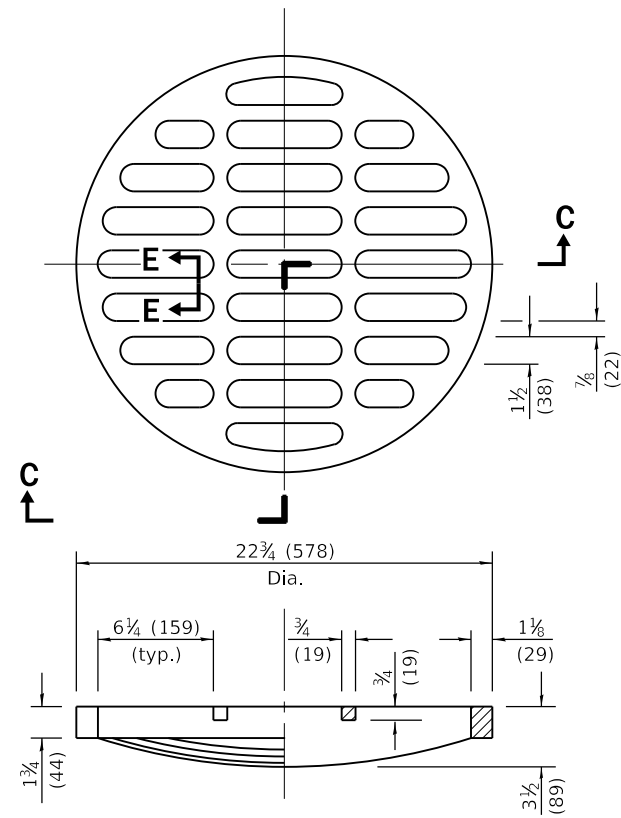

SECTION C-C
CAST OPEN LID

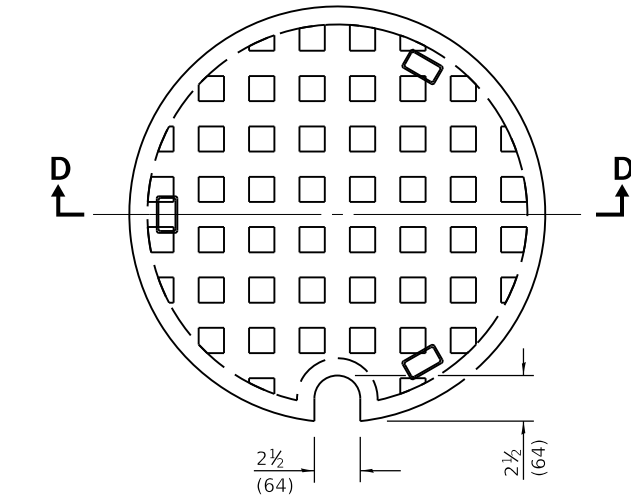

SECTION D-D
CAST CLOSED LID
Gray Iron

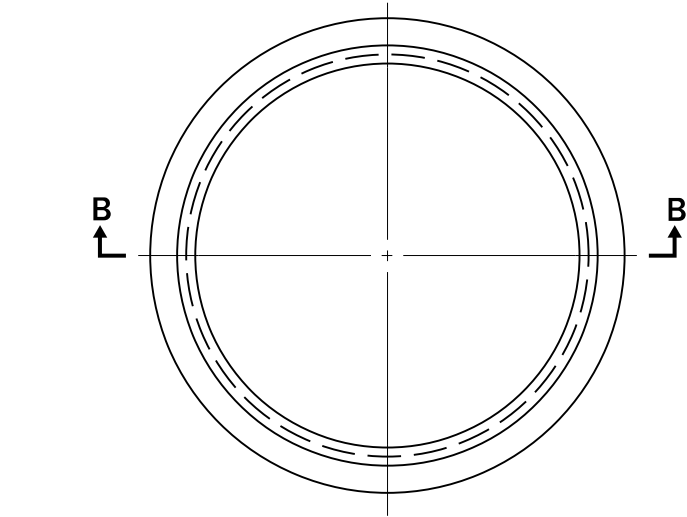

SECTION B-B
CAST FRAME
Gray Iron

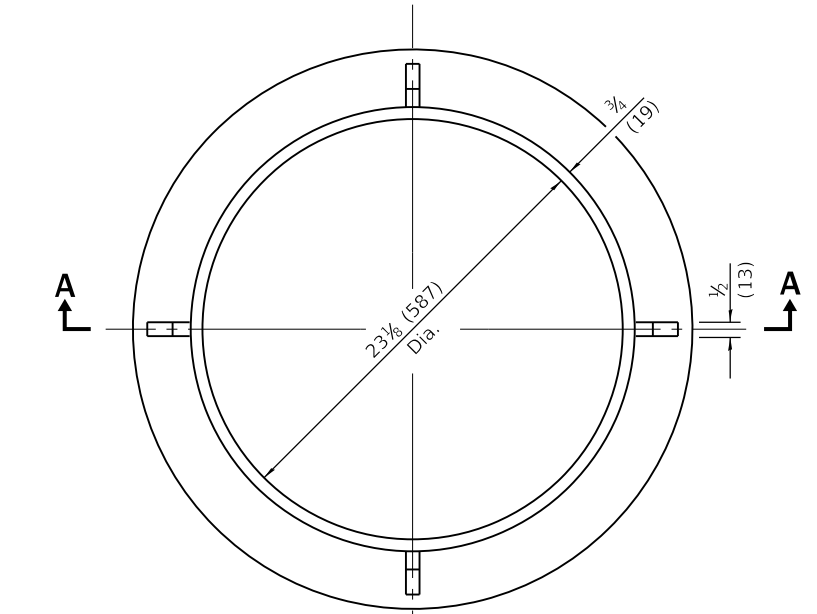

SECTION A-A
CAST BASE
Gray Iron

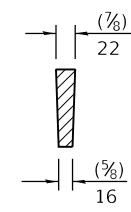

SECTION E-E

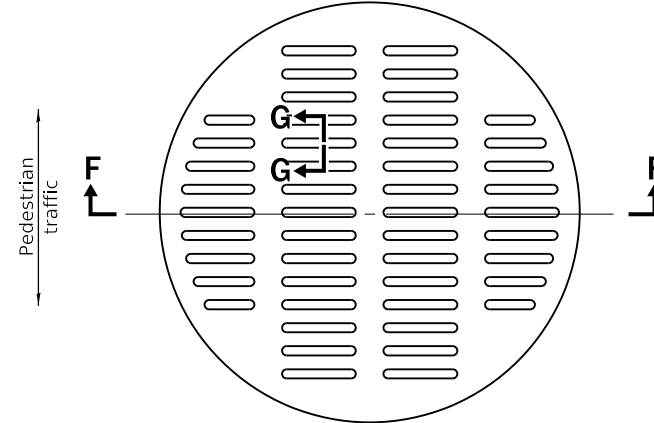

SECTION F-F
ADA COMPLIANT
CAST OPEN LID

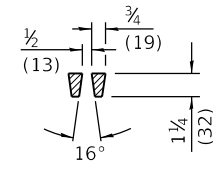

SECTION G-G

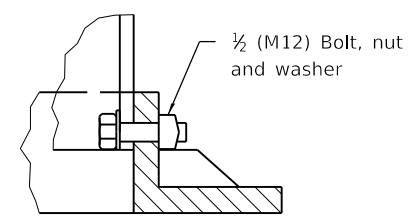
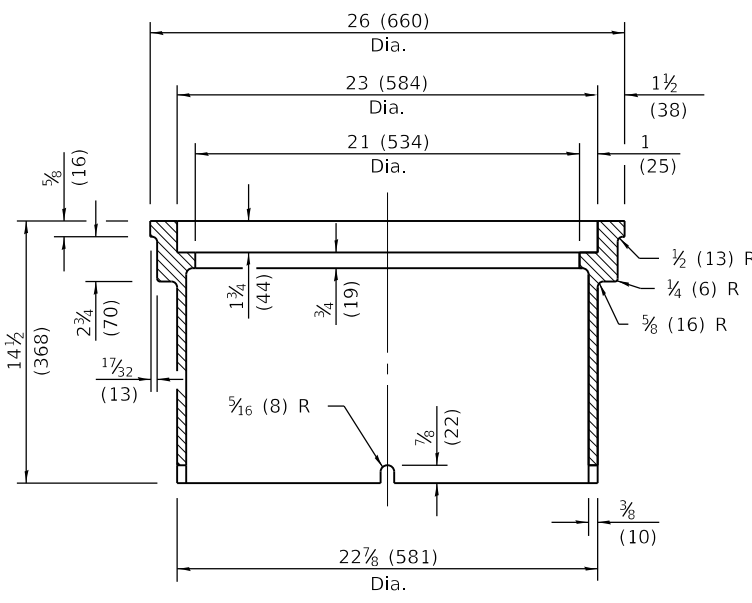

DETAIL OF BOLTING
FRAME TO BASE

NOTE: Bolts shall be removed after pavement has been placed.

GENERAL NOTES
The four holes in the cast base may be rotated 45° from the position shown in section A-A
All dimensions are in inches (millimeters) unless otherwise shown.

DATE	REVISIONS
1-1-20	Revised dimension location in Section A-A.
1-1-15	Added ADA compliant open lid.
1-1-09	Switched units to English (metric).

BASE, FRAME AND LIDS TYPE 5

STANDARD 604021-04

Illinois Department of Transportation

PASSED January 1, 2020
Michael Bond
ENGINEER OF POLICY AND PROCEDURES

APPROVED January 1, 2020
J. S. E. E.
ENGINEER OF DESIGN AND ENVIRONMENT

ISSUED 1-1-20
46-T

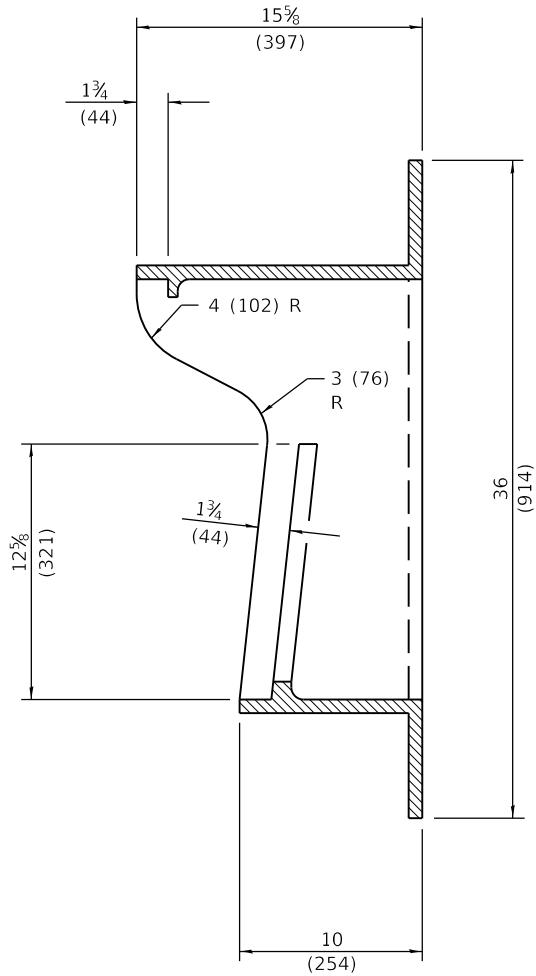
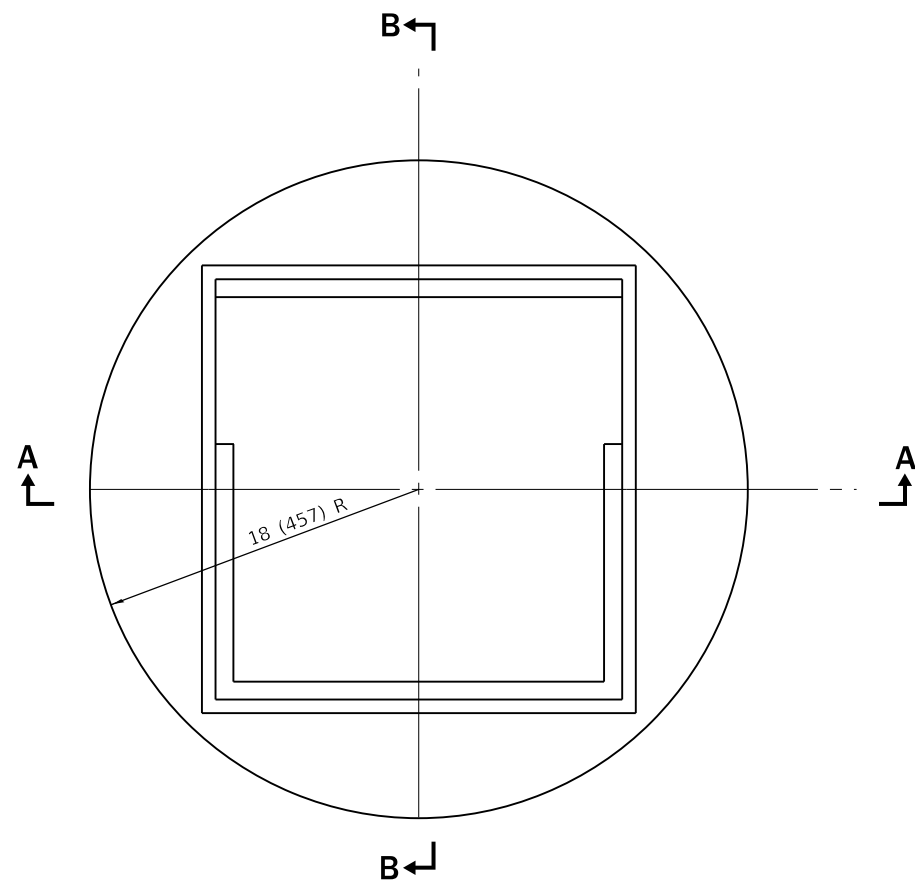

SECTION B-B

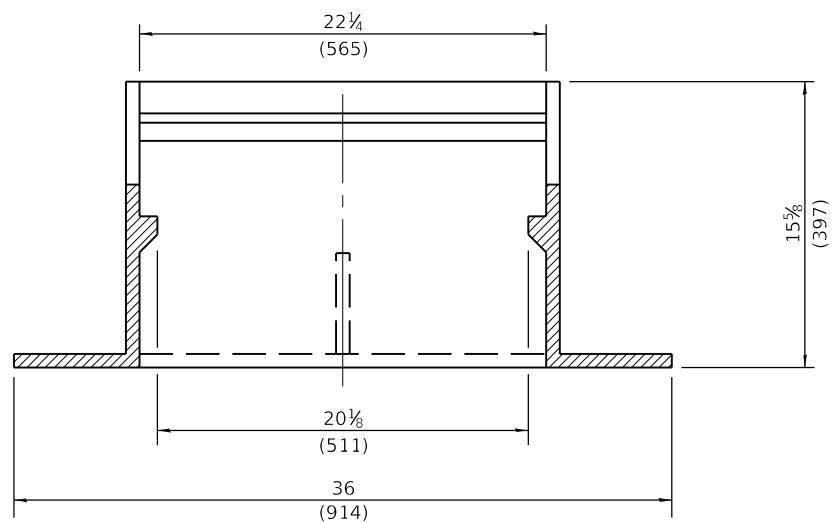

SECTION A-A

CAST FRAME

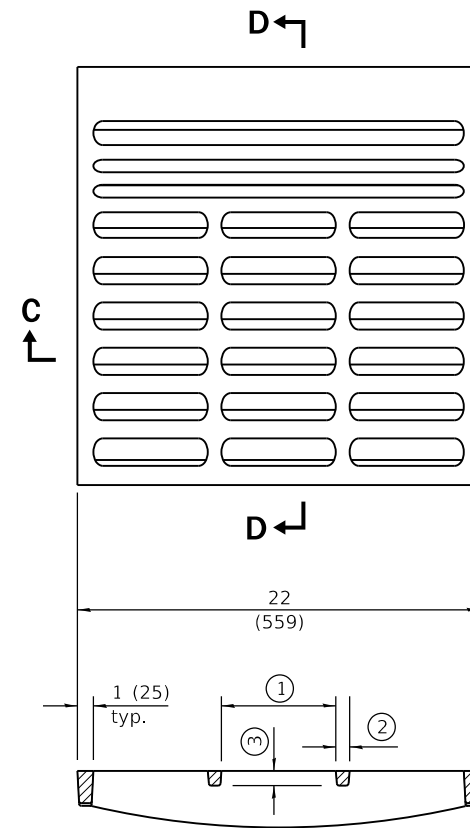

SECTION C-C

- ① = 6 1/4 (159) max. (typ.)
- ② = 3/4 (19) min. (typ.)
- ③ = 3/16 (21) min. (typ.)

CAST GRATE

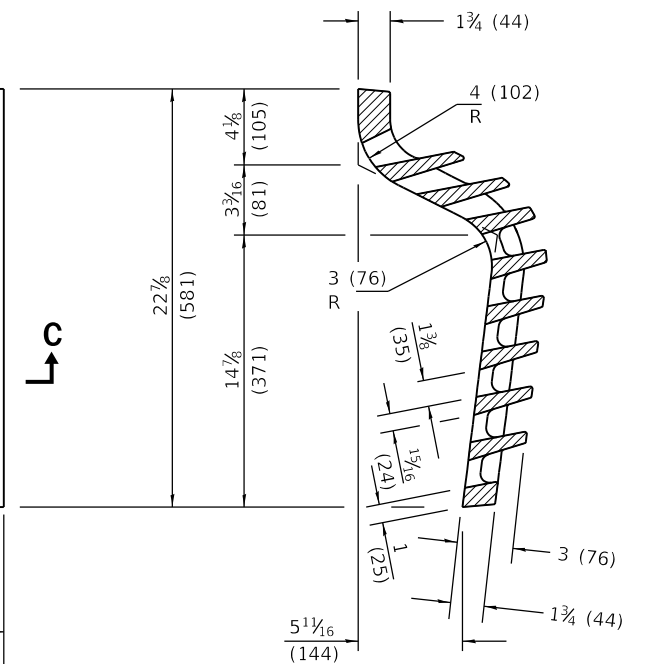

SECTION D-D

All dimensions are in inches (millimeters) unless otherwise shown.

Illinois Department of Transportation

PASSED January 1, 2015
Michael Beard
 ENGINEER OF POLICY AND PROCEDURES

APPROVED January 1, 2015
[Signature]
 ENGINEER OF DESIGN AND ENVIRONMENT

ISSUED 1-1-97

DATE	REVISIONS
1-1-15	Revised dimensions of frame and grate.
1-1-09	Switched units to English (metric).

**FRAME AND GRATE
TYPE 6**

STANDARD 604026-03

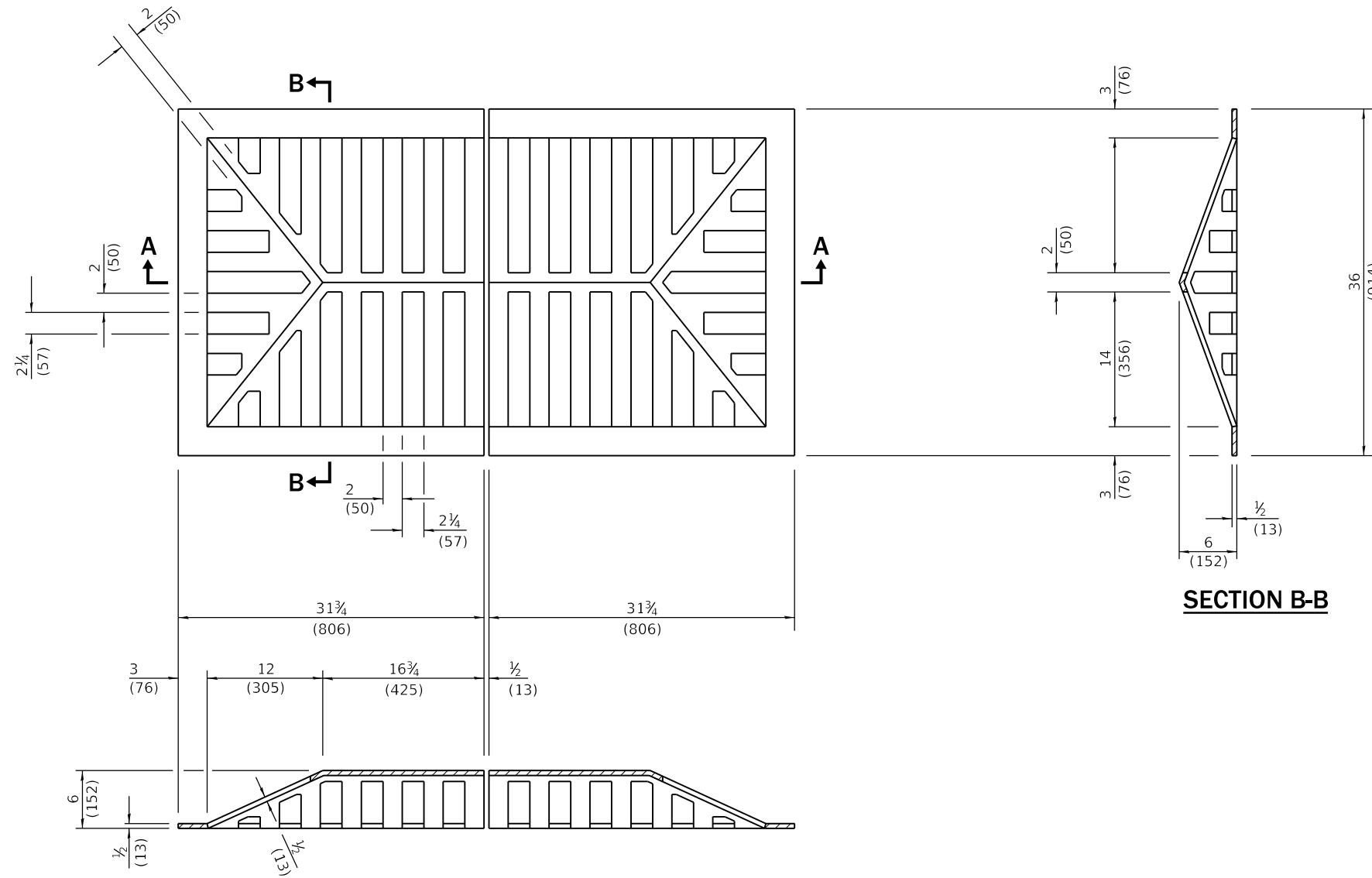

SECTION A-A

SECTION B-B

CAST GRATE

All dimensions are in inches (millimeters) unless otherwise shown.

Illinois Department of Transportation

PASSED January 1, 2015
Michael Beard
 ENGINEER OF POLICY AND PROCEDURES

APPROVED January 1, 2015
[Signature]
 ENGINEER OF DESIGN AND ENVIRONMENT

ISSUED 1-1-97

DATE	REVISIONS
1-1-15	Revised grate thickness.
1-1-09	Switched units to English (metric).

GRATE TYPE 7

STANDARD 604031-03

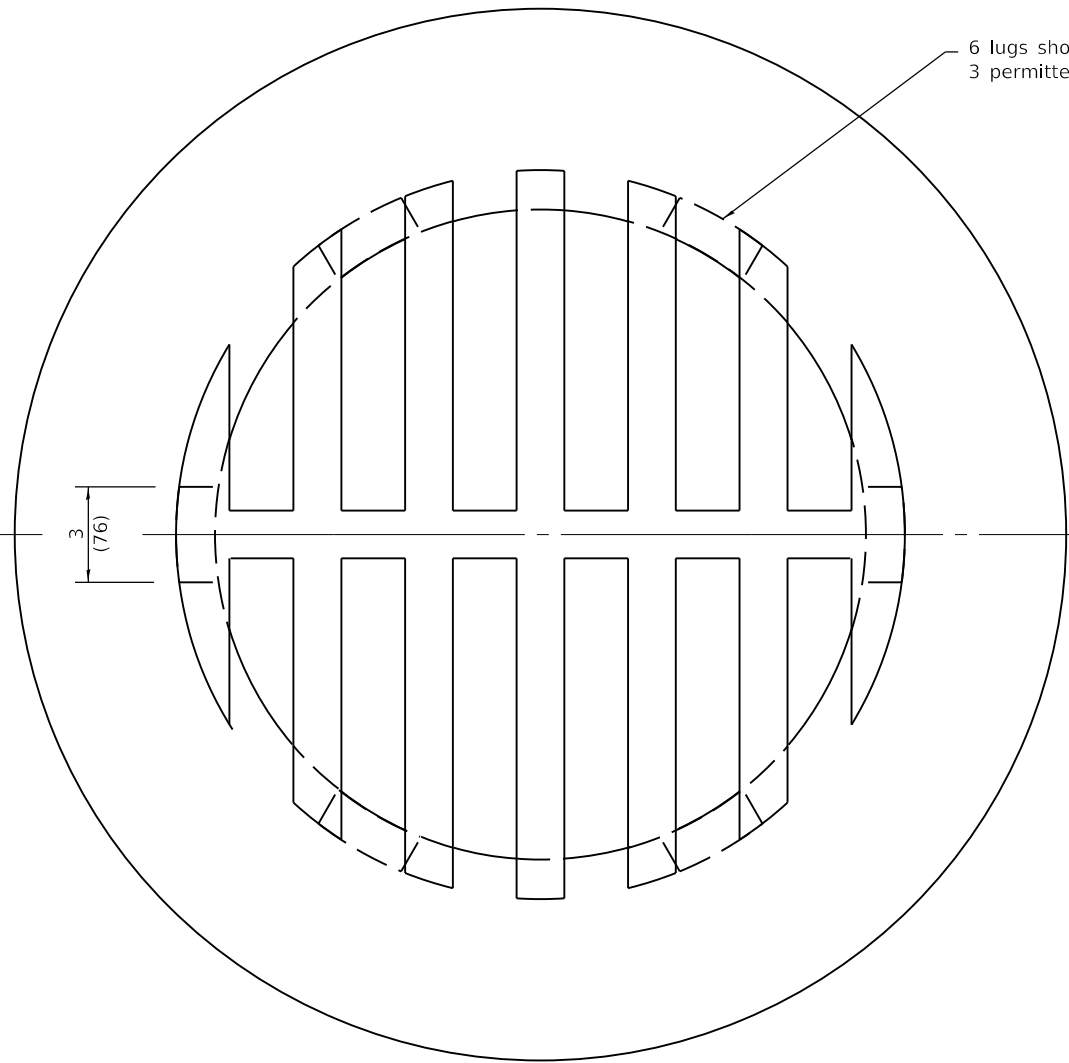

6 lugs shown,
3 permitted.

A
↑

A
↑

CAST GRATE

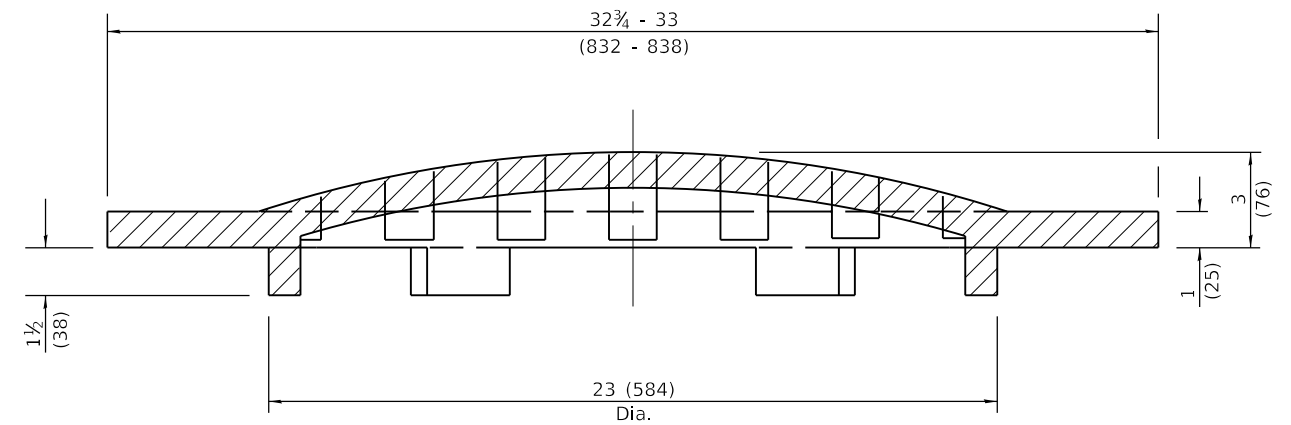

SECTION A-A

All dimensions are in inches (millimeters)
unless otherwise shown.

 Illinois Department of Transportation
 PASSED January 1, 2015
Michael Beard
 ENGINEER OF POLICY AND PROCEDURES
 APPROVED January 1, 2015
[Signature]
 ENGINEER OF DESIGN AND ENVIRONMENT
 ISSUED 1-1-97

DATE	REVISIONS
1-1-15	Revised dimensions.
1-1-09	Switched units to English (metric).

GRATE TYPE 8

STANDARD 604036-03

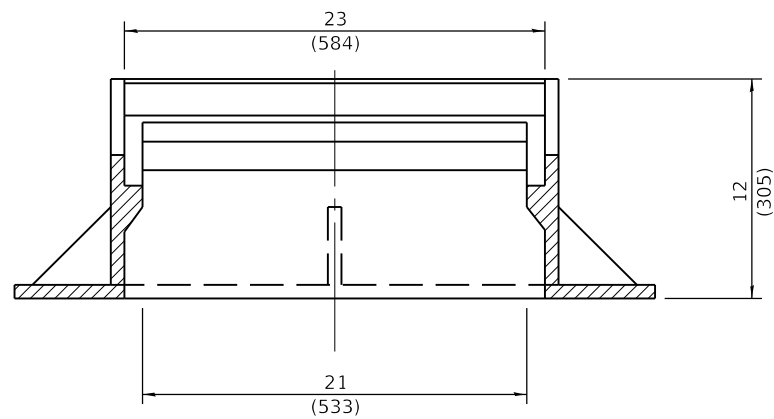
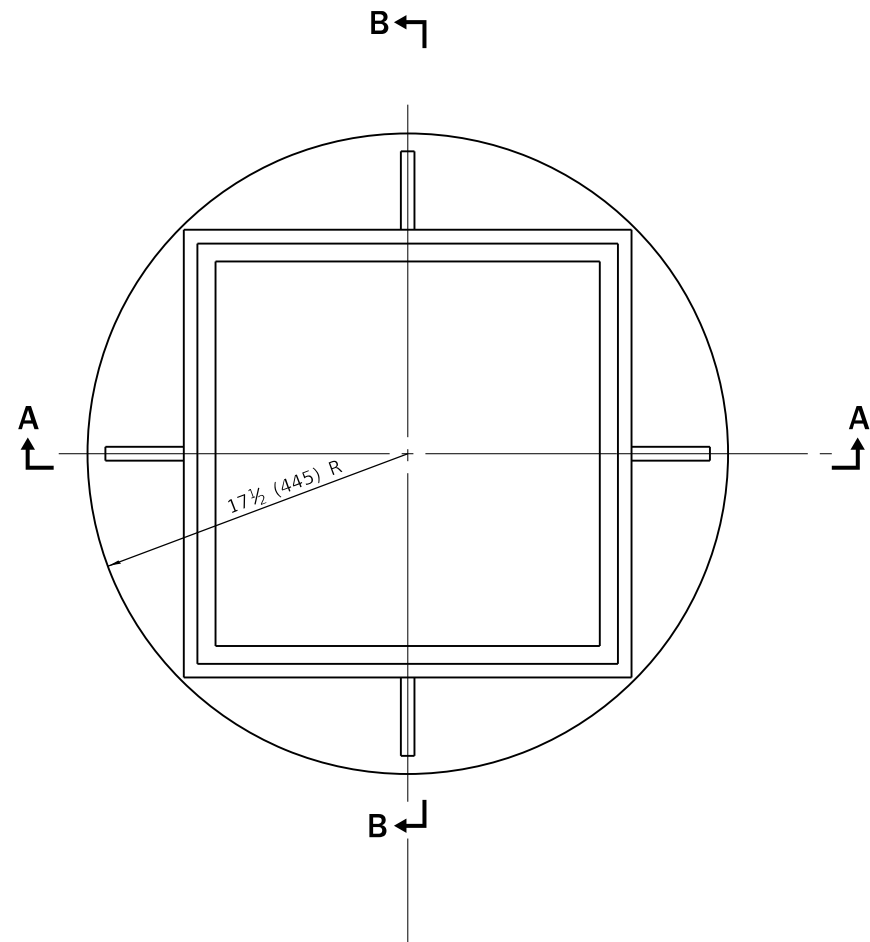

SECTION A-A

CAST FRAME

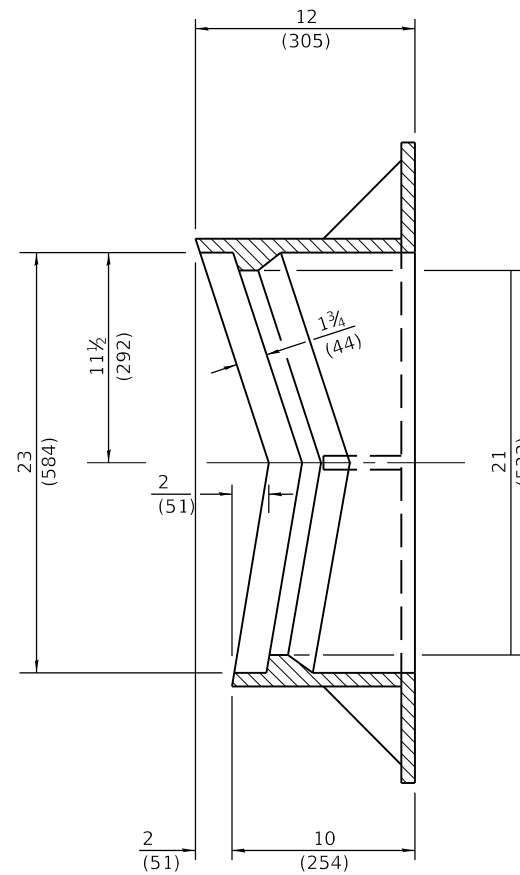

SECTION B-B

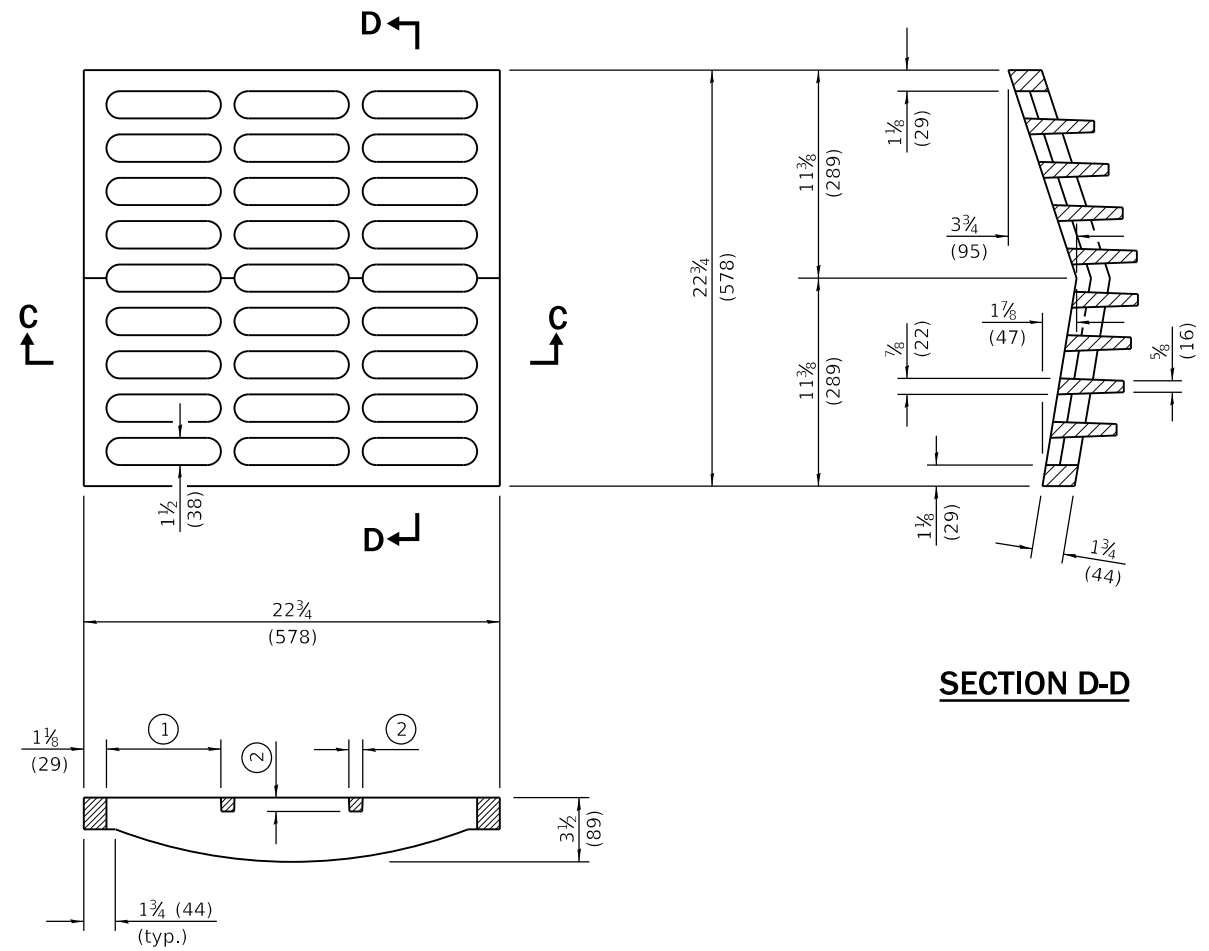

SECTION D-D

SECTION C-C

- ① = 6 1/4 (159) max. (typ.)
- ② = 3/4 (19) min. (typ.)

CAST GRATE

All dimensions are in inches (millimeters) unless otherwise shown.

DATE	REVISIONS
1-1-15	Revised dimensions of frame.
1-1-09	Switched units to English (metric).

**FRAME AND GRATE
TYPE 9**

STANDARD 604041-03

Illinois Department of Transportation

PASSED January 1, 2015
Michael Beard
 ENGINEER OF POLICY AND PROCEDURES

APPROVED January 1, 2015
[Signature]
 ENGINEER OF DESIGN AND ENVIRONMENT

ISSUED 1-1-97

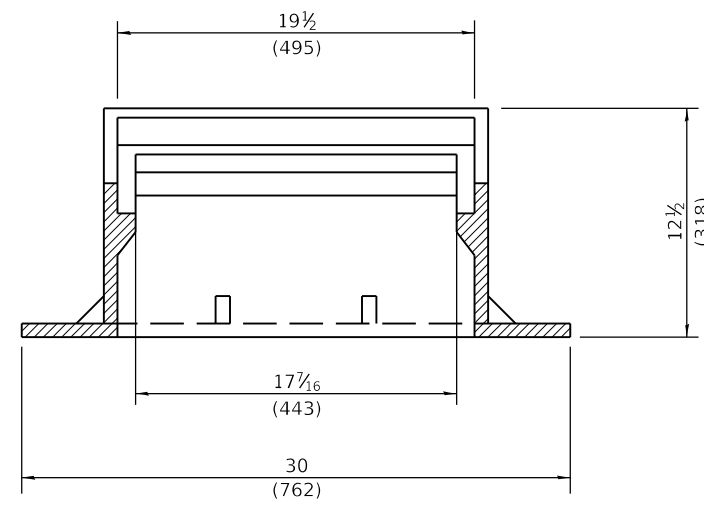
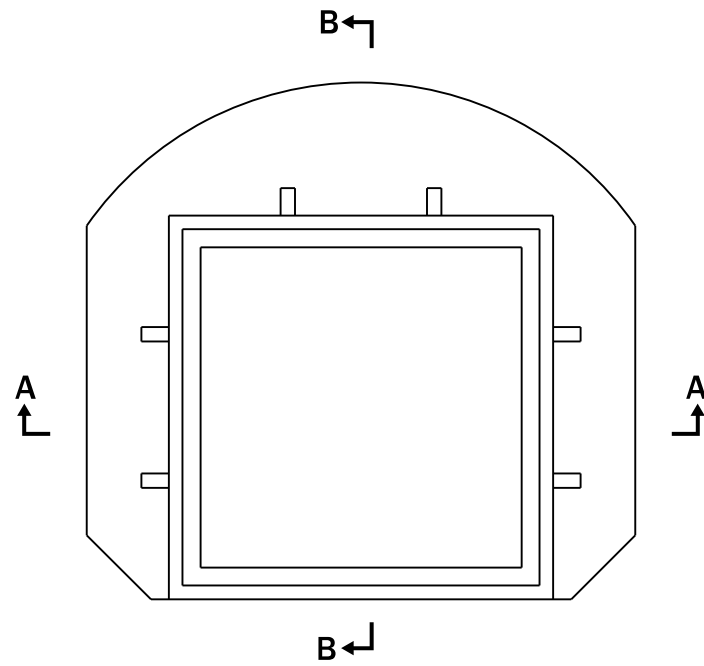

SECTION A-A

CAST FRAME

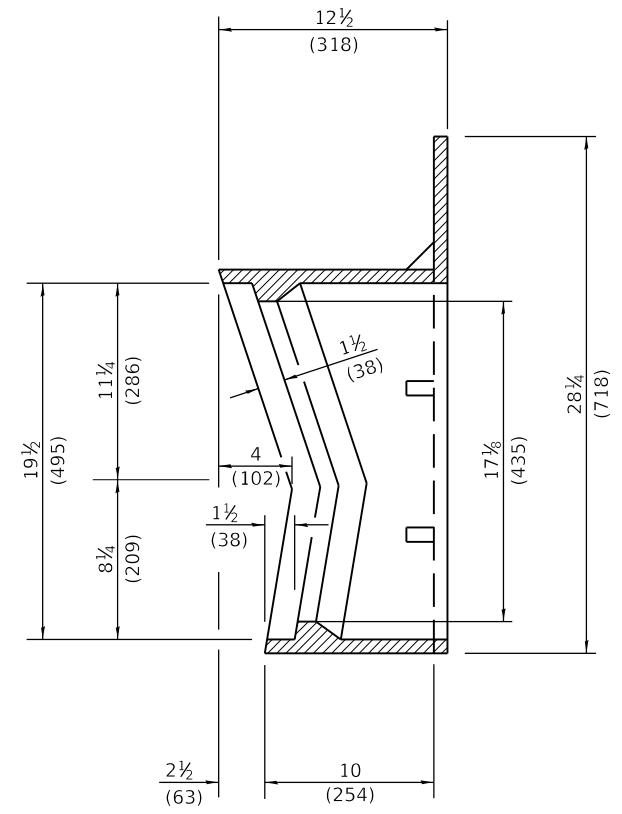

SECTION B-B

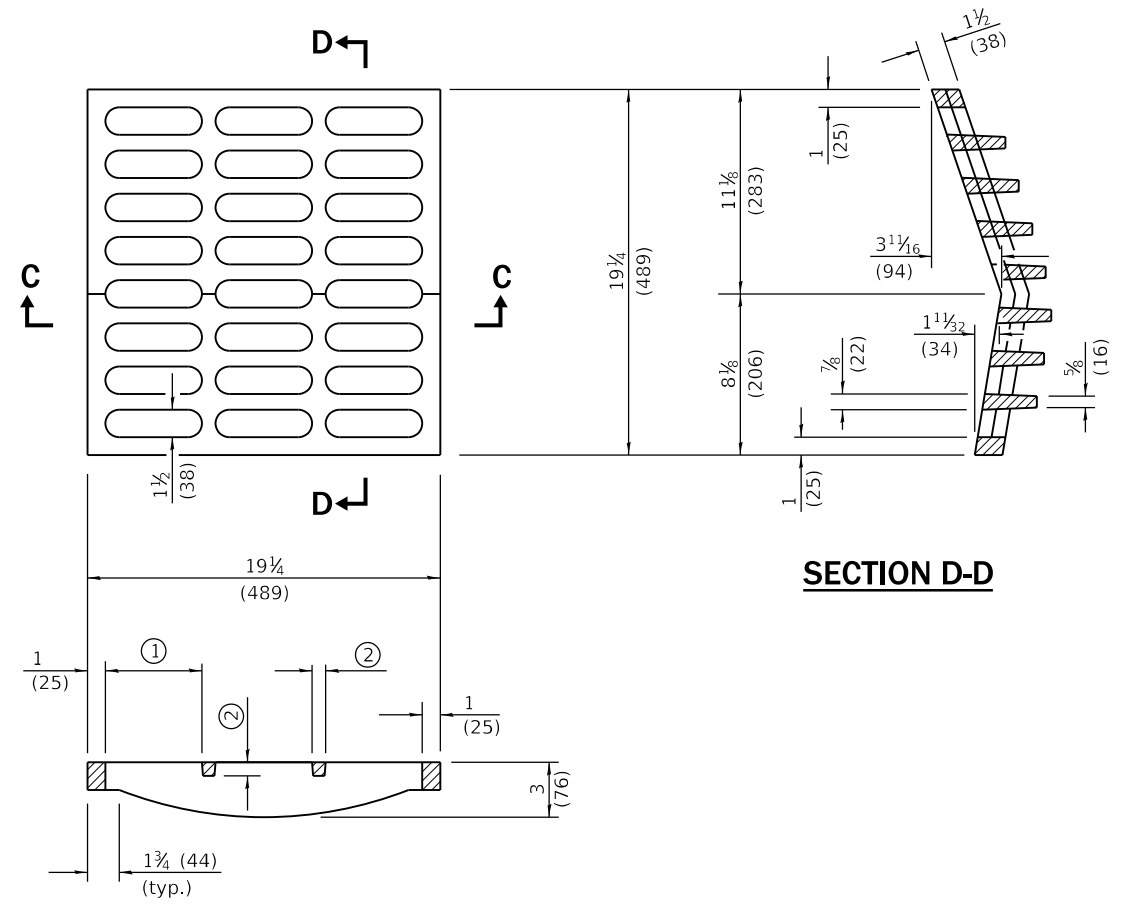

SECTION D-D

SECTION C-C

- ① = 6 1/4 (159) max. (typ.)
- ② = 3/4 (19) min. (typ.)

CAST GRATE

All dimensions are in inches (millimeters) unless otherwise shown.

Illinois Department of Transportation

PASSED January 1, 2015
Michael Beard
 ENGINEER OF POLICY AND PROCEDURES

APPROVED January 1, 2015
[Signature]
 ENGINEER OF DESIGN AND ENVIRONMENT

ISSUED 1-1-97

DATE	REVISIONS
1-1-15	Revised dimensions of frame.
1-1-09	Switched units to English (metric).

**FRAME AND GRATE
TYPE 10**

STANDARD 604046-03

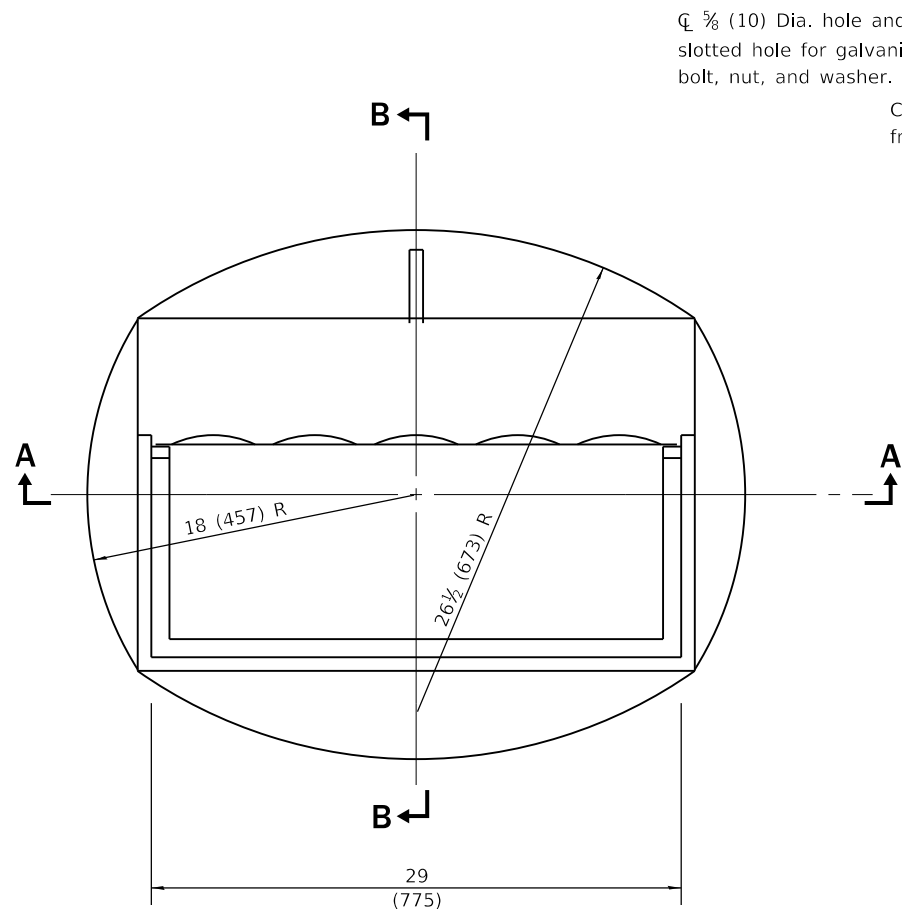

CAST FRAME

☒ 3/8 (10) Dia. hole and 3/8x5 1/2 (16x140) slotted hole for galvanized 1/2 (M12) bolt, nut, and washer.
Curb box adjustable from 4 1/2 (115) to 9 (225)

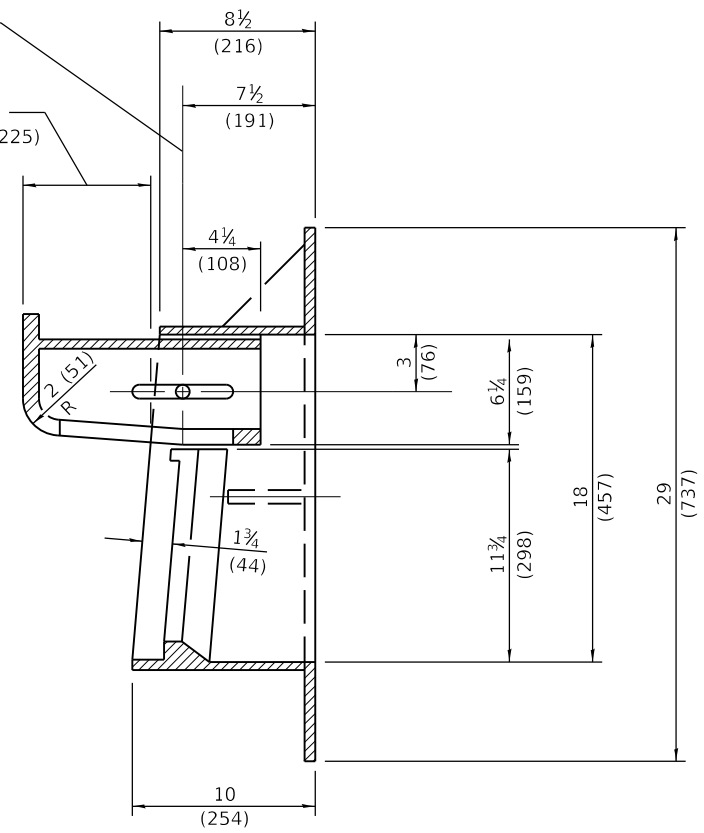

SECTION B-B

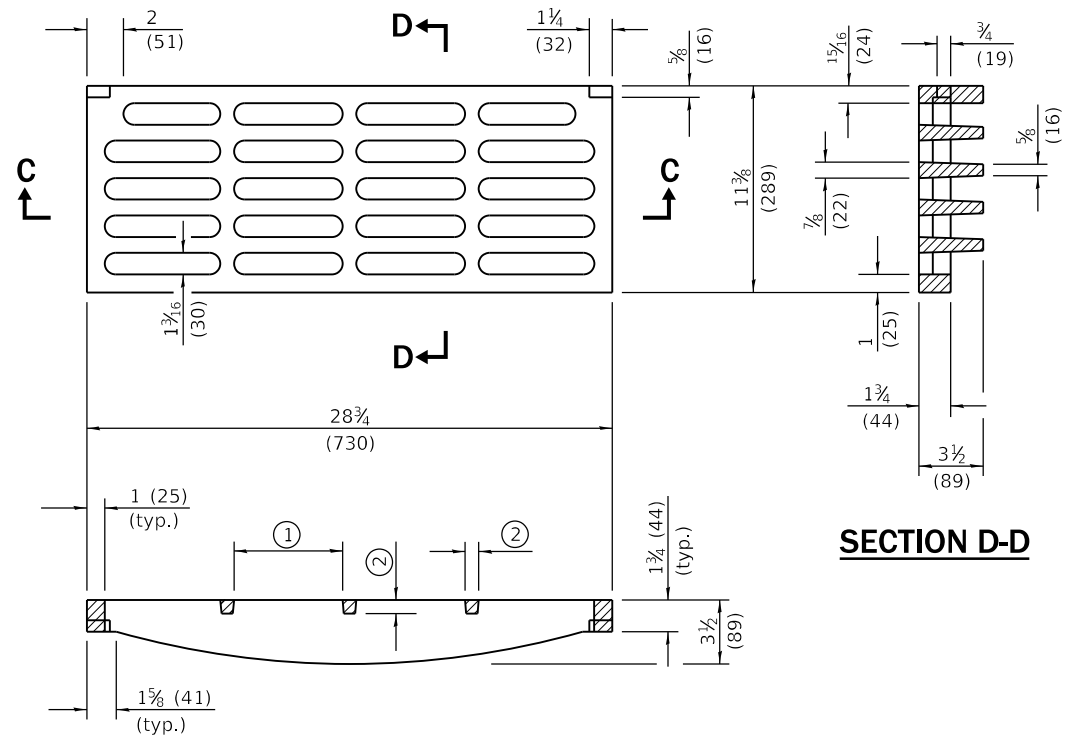

SECTION C-C

- ① = 6 1/4 (159) max. (typ.)
- ② = 3/4 (19) min. (typ.)

CAST GRATE

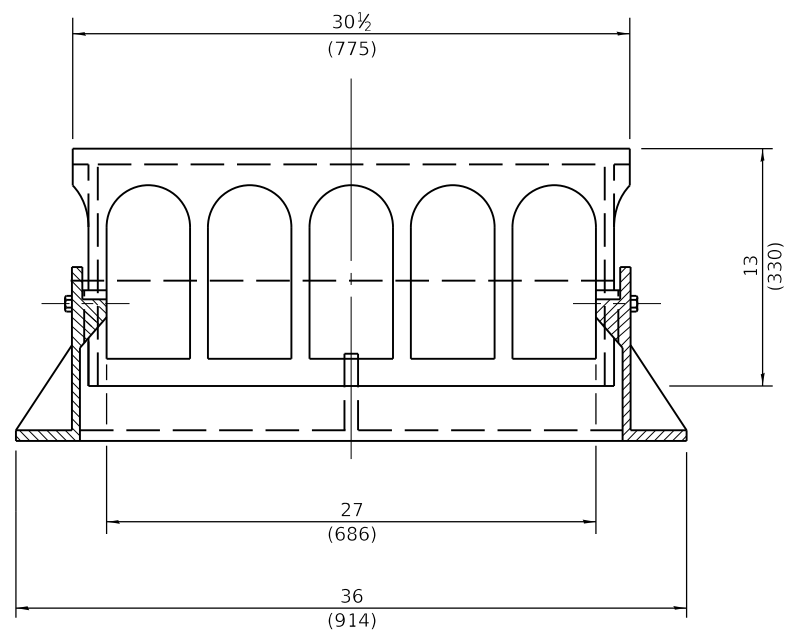

SECTION A-A

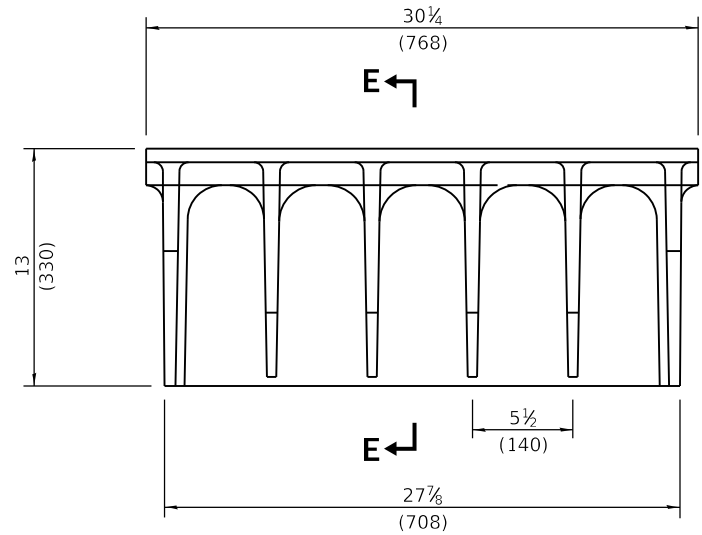

ALTERNATE CURB BOX

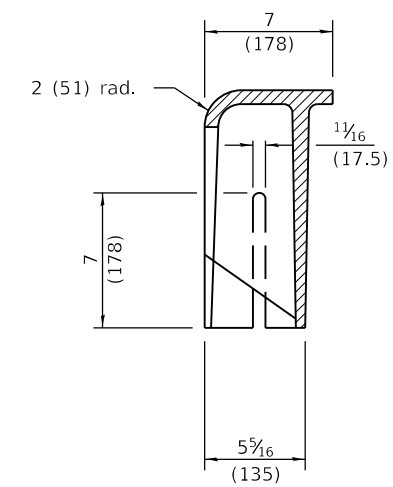

SECTION E-E

All dimensions are in inches (millimeters) unless otherwise shown.

Illinois Department of Transportation

PASSED January 1, 2015
Michael Beard
ENGINEER OF POLICY AND PROCEDURES

APPROVED January 1, 2015
[Signature]
ENGINEER OF DESIGN AND ENVIRONMENT

ISSUED 1-1-97

DATE	REVISIONS
1-1-15	Revised dimensions of frame and alternate curb box.
4-1-09	Switched units to English (metric).

**FRAME AND GRATE
TYPE 11**

STANDARD 604051-04

⌀ 5/8 (10) Dia. hole and 5/8x5 1/2 (16x140) slotted hole for galvanized 1/2 (M12) bolt, nut, and washer.

Curb box adjustable from 4 1/2 (115) to 9 (225)

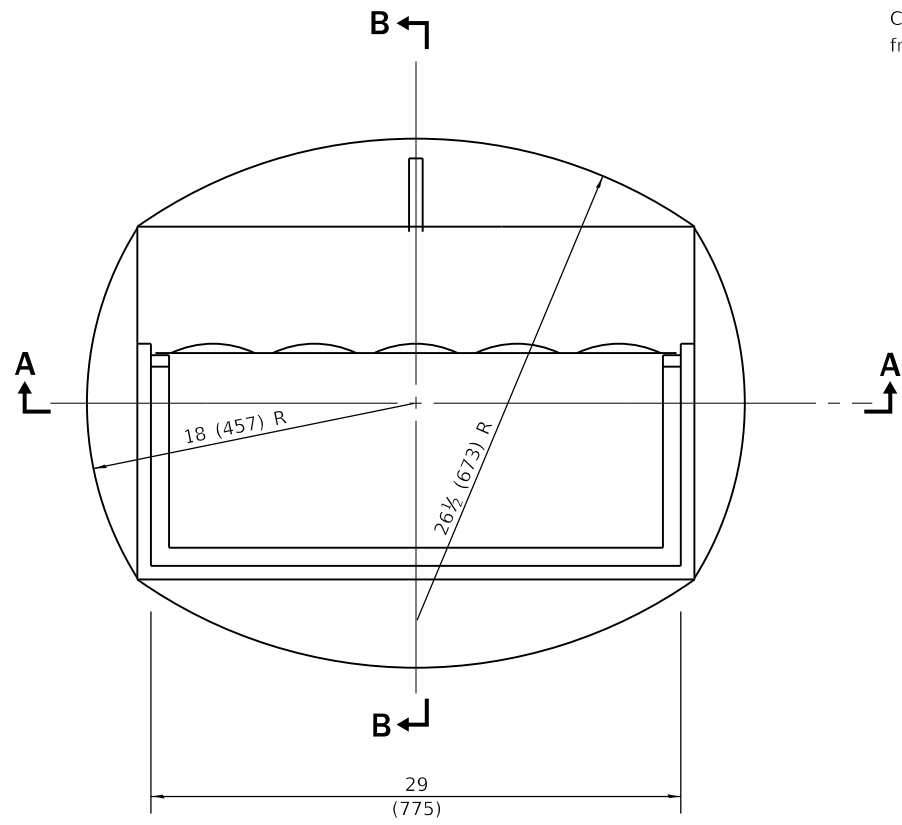

CAST FRAME

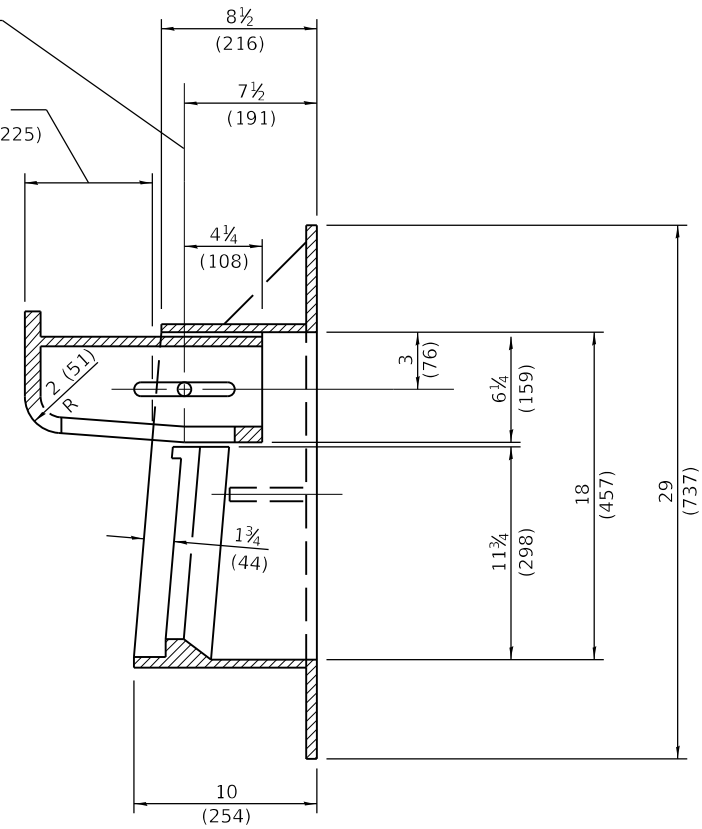

SECTION B-B

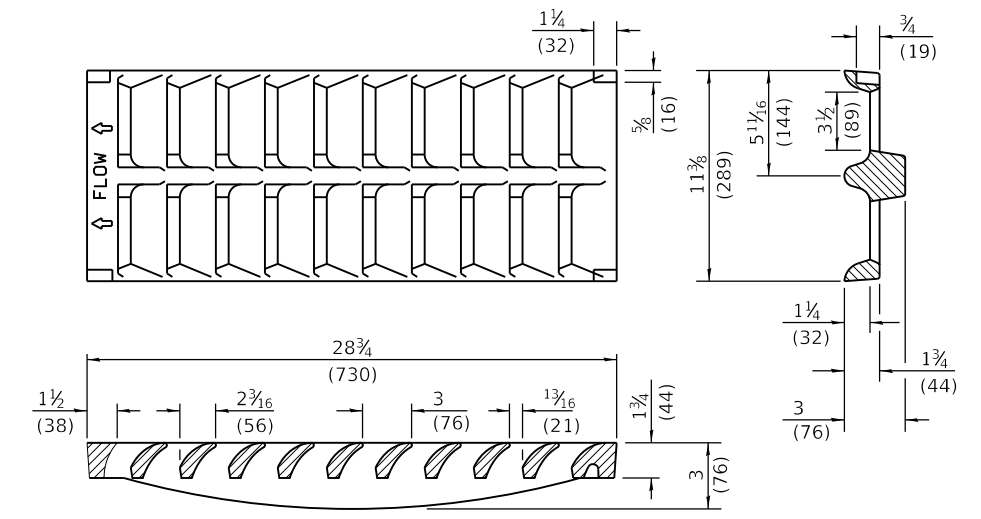

CAST GRATE

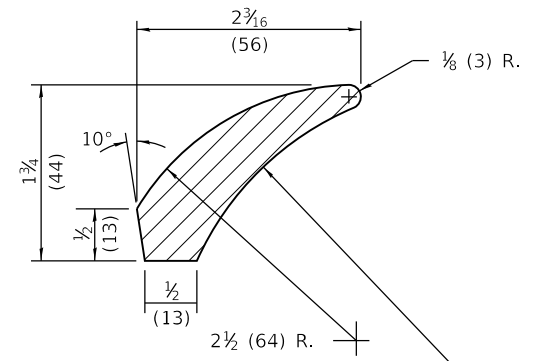

VANE DETAIL

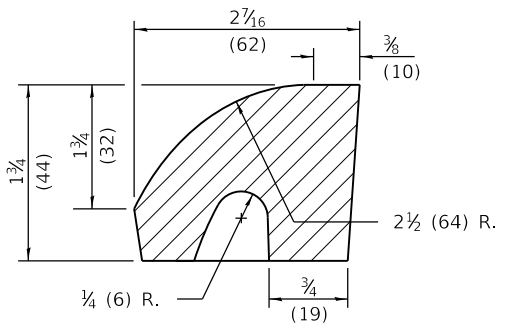

FRONT VANE DETAIL

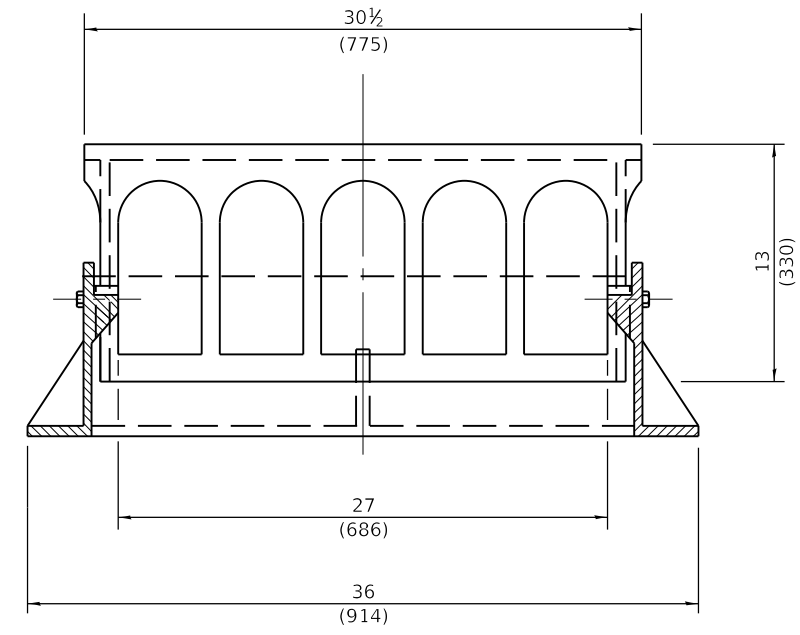

SECTION A-A

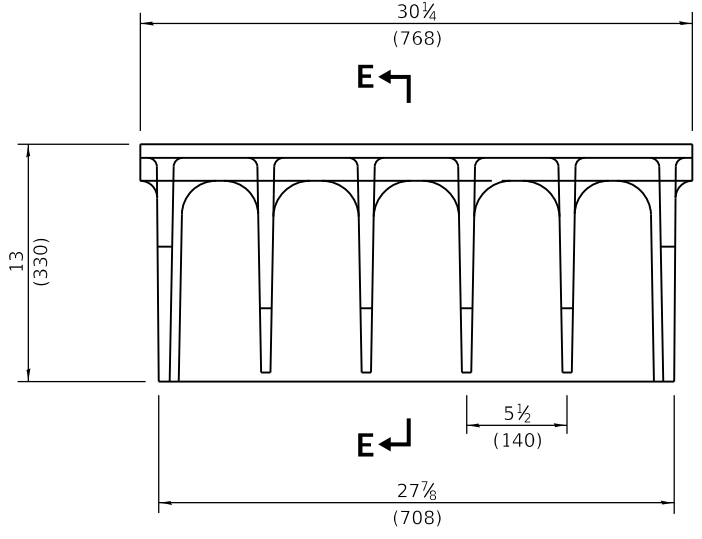

ALTERNATE CURB BOX

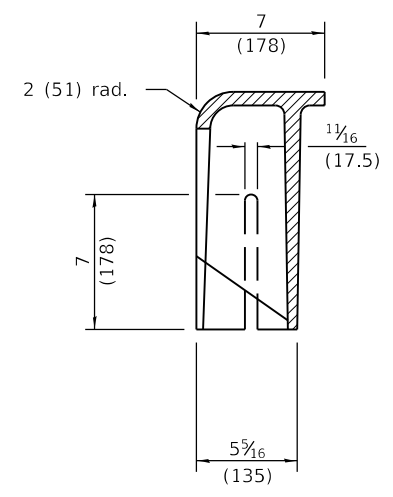

SECTION E-E

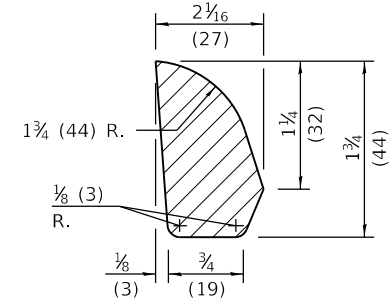

SIDE RIB DETAIL

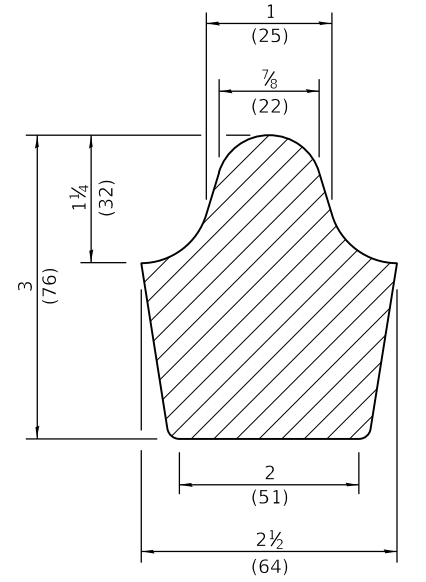

MIDDLE RIB DETAIL

All dimensions are in inches (millimeters) unless otherwise shown.

Illinois Department of Transportation

PASSED January 1, 2015
Michael Beard
 ENGINEER OF POLICY AND PROCEDURES

APPROVED January 1, 2015
[Signature]
 ENGINEER OF DESIGN AND ENVIRONMENT

ISSUED 1-1-97

DATE	REVISIONS
1-1-15	Revised dimensions of frame and alternate curb box.
1-1-09	Switched units to English (metric).

**FRAME AND GRATE
TYPE 11V**

STANDARD 604056-04

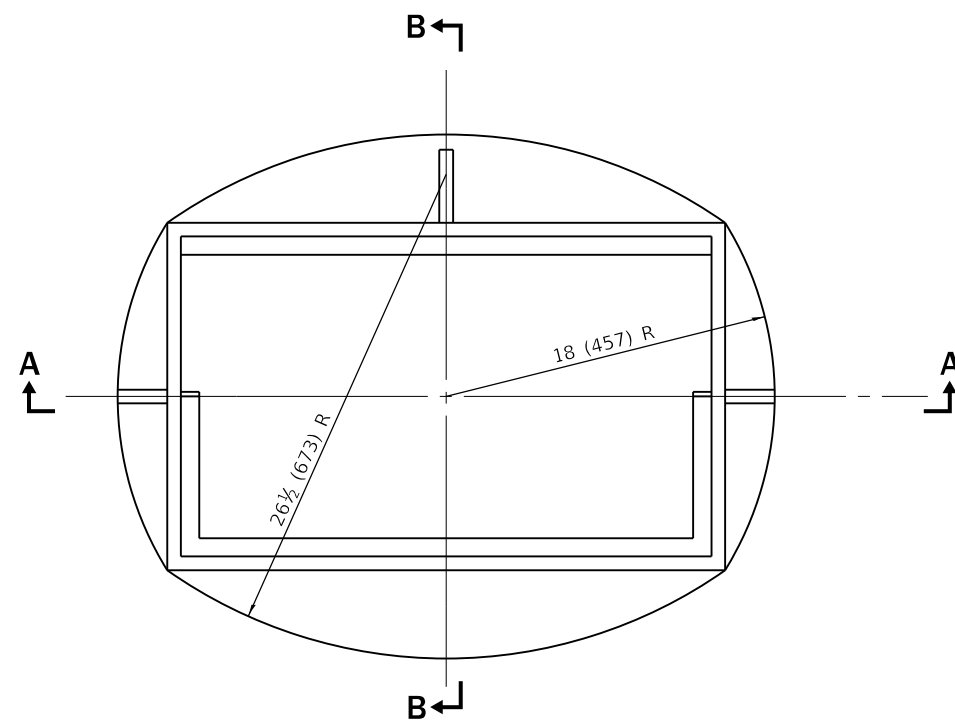

SECTION A-A

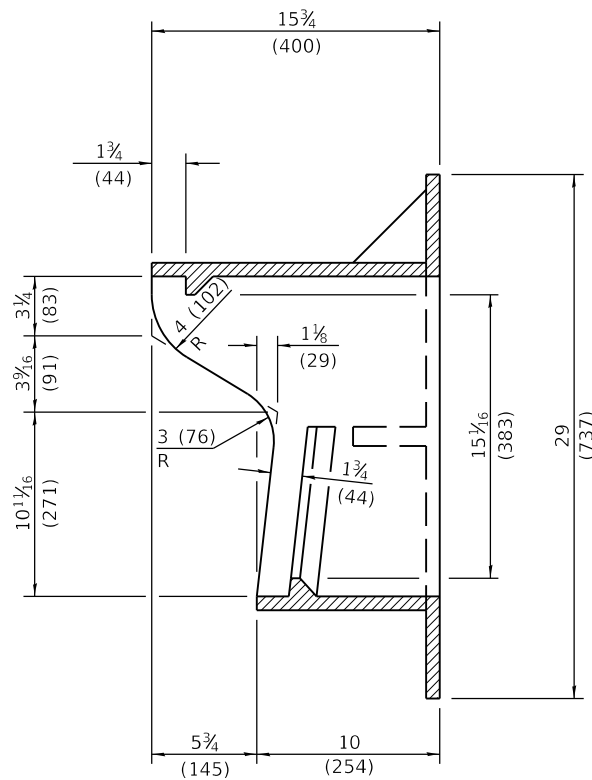

SECTION B-B

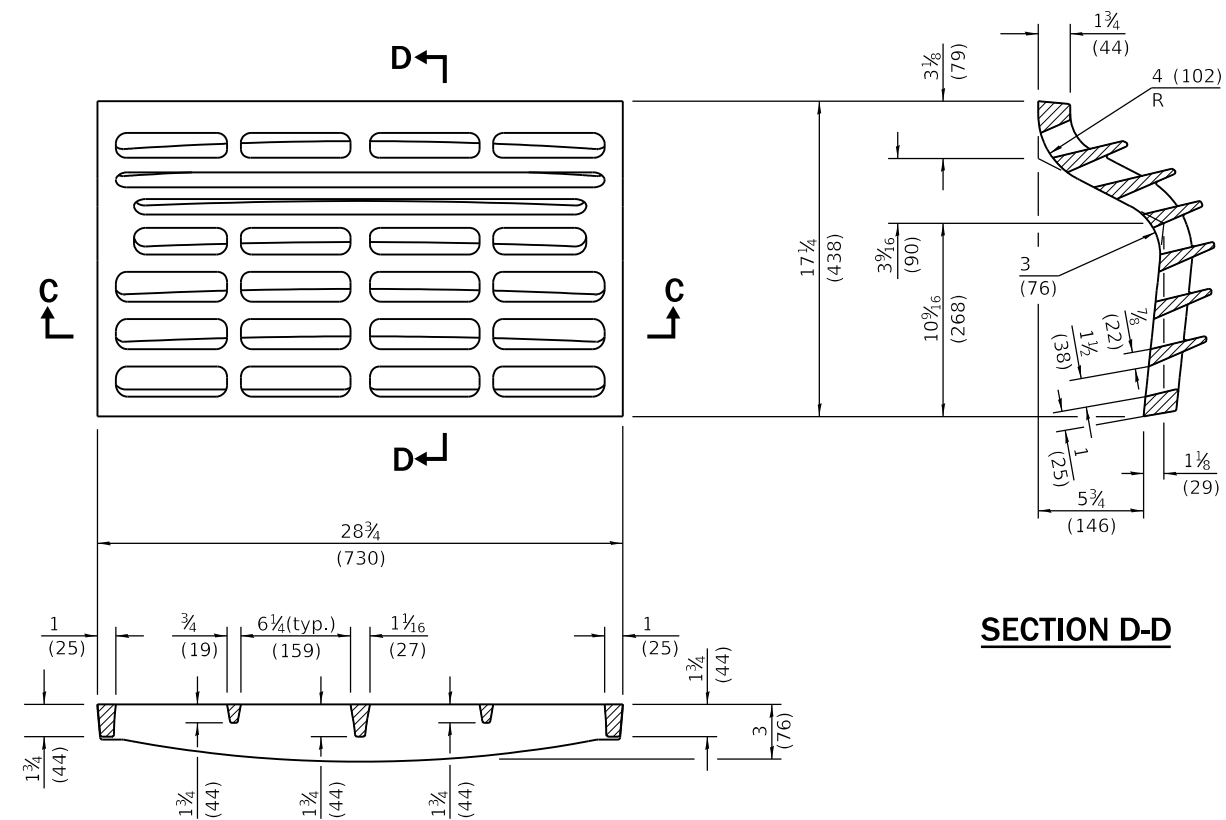

SECTION C-C

SECTION D-D

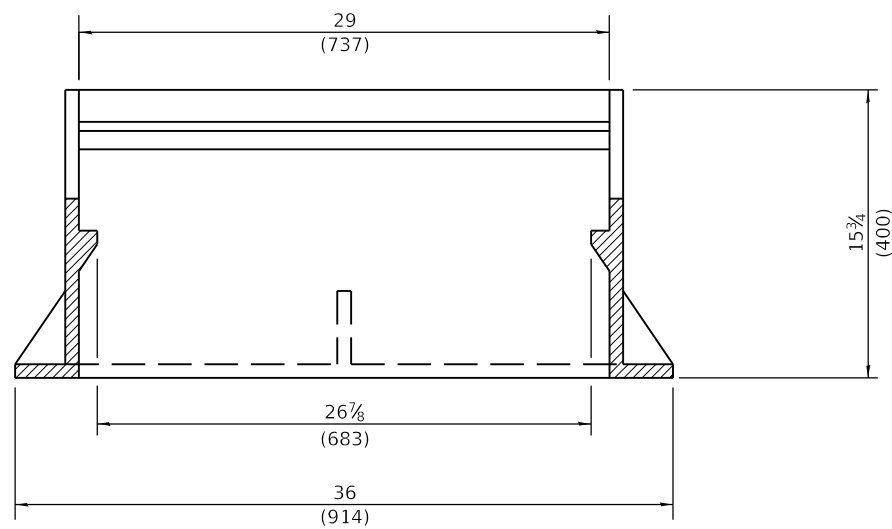

CAST FRAME

CAST GRATE

All dimensions are in inches (millimeters) unless otherwise shown.

Illinois Department of Transportation
 PASSED January 1, 2015
Michael Beard
 ENGINEER OF POLICY AND PROCEDURES
 APPROVED January 1, 2015
[Signature]
 ENGINEER OF DESIGN AND ENVIRONMENT
 ISSUED 1-1-97

DATE	REVISIONS
1-1-15	Revised dimensions of frame and grate.
1-1-09	Switched units to English (metric).

**FRAME AND GRATE
TYPE 12**

STANDARD 604061-03

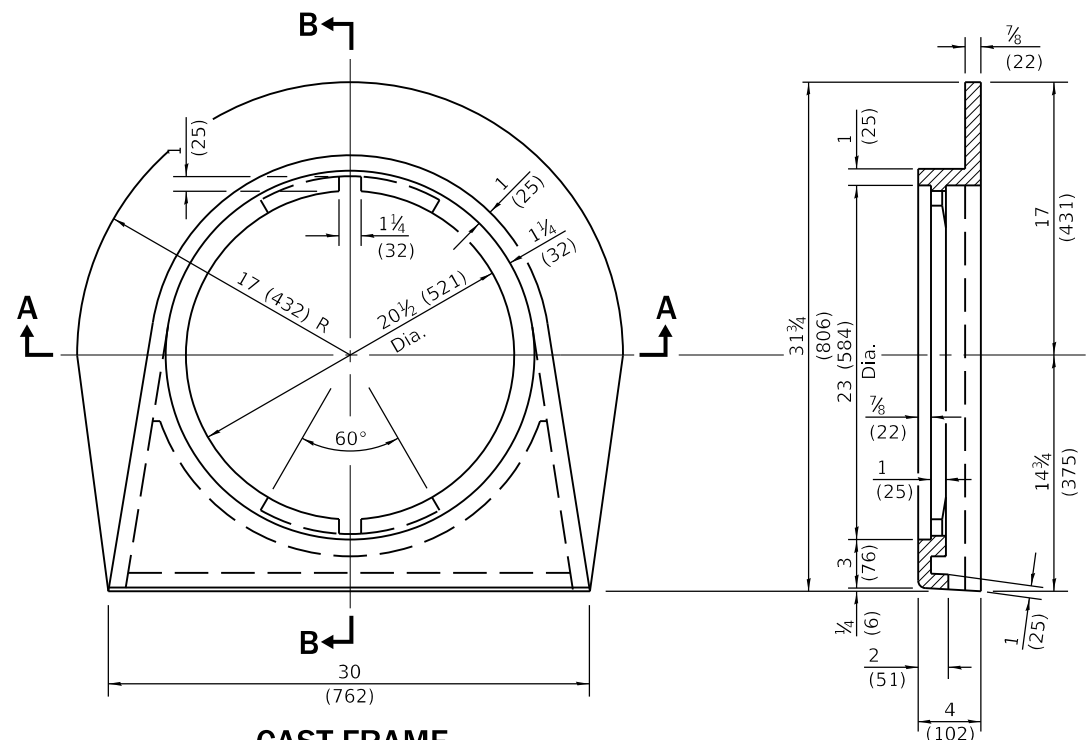

CAST FRAME
(GRAY IRON)

SECTION B-B

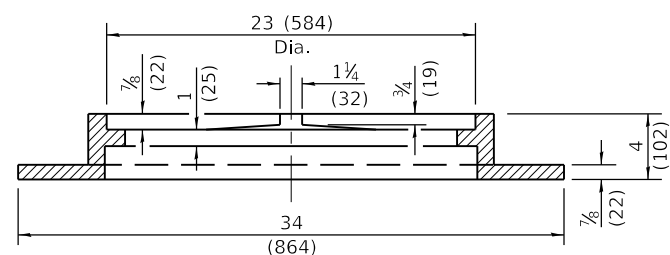

SECTION A-A

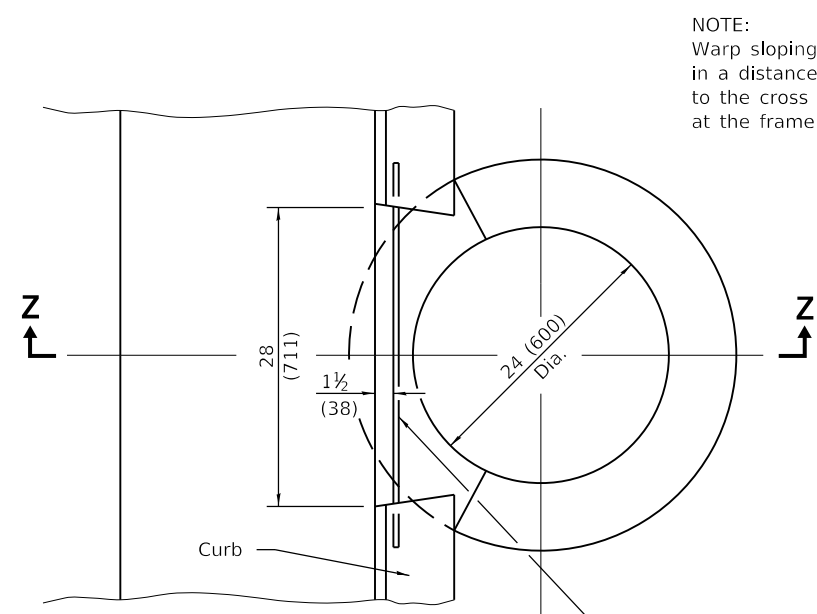

SECTION Z-Z
(WITH FRAME)

CASE II

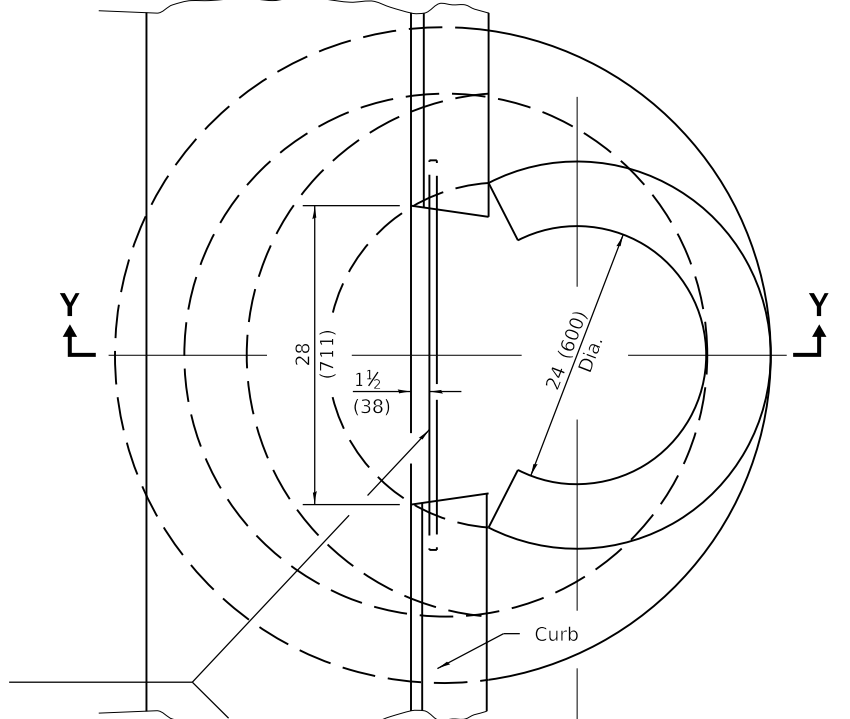

SECTION Y-Y
(WITH FRAME)

CASE I

NOTE:
Warp sloping face of curbs
in a distance of 5' (1.5 m)
to the cross section shown
at the frame.

No. 6 x 36 (No. 20 x 900)
re-bar required when
X = 5 (125) or more

Slope pavement
or gutter flag
12% at inlet.

Slope pavement
or gutter flag
12% at inlet.

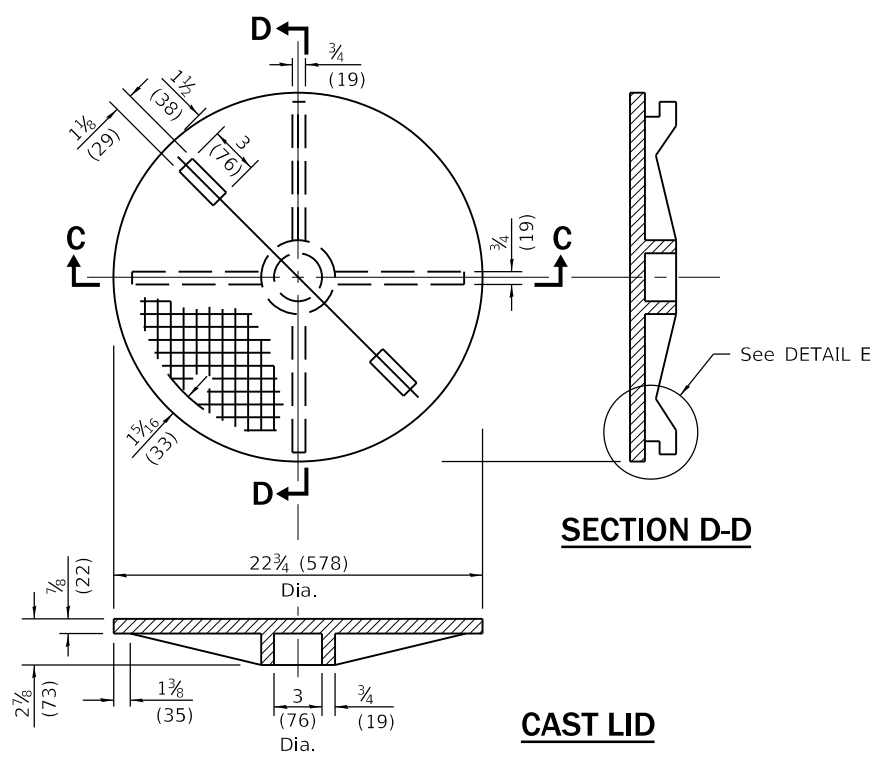

SECTION D-D

CAST LID

SECTION C-C

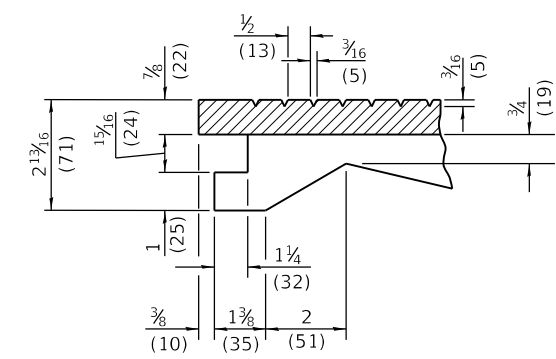

DETAIL E

All dimensions are in inches (millimeters)
unless otherwise shown.

Illinois Department of Transportation

PASSED January 1, 2009

ENGINEER OF POLICY AND PROCEDURES

APPROVED January 1, 2009

ENGINEER OF DESIGN AND ENVIRONMENT

ISSUED 1-1-09

DATE	REVISIONS
1-1-09	Switched units to English (metric).
1-1-04	Removed weights.

**FRAME AND LID
TYPE 15**

STANDARD 604066-02

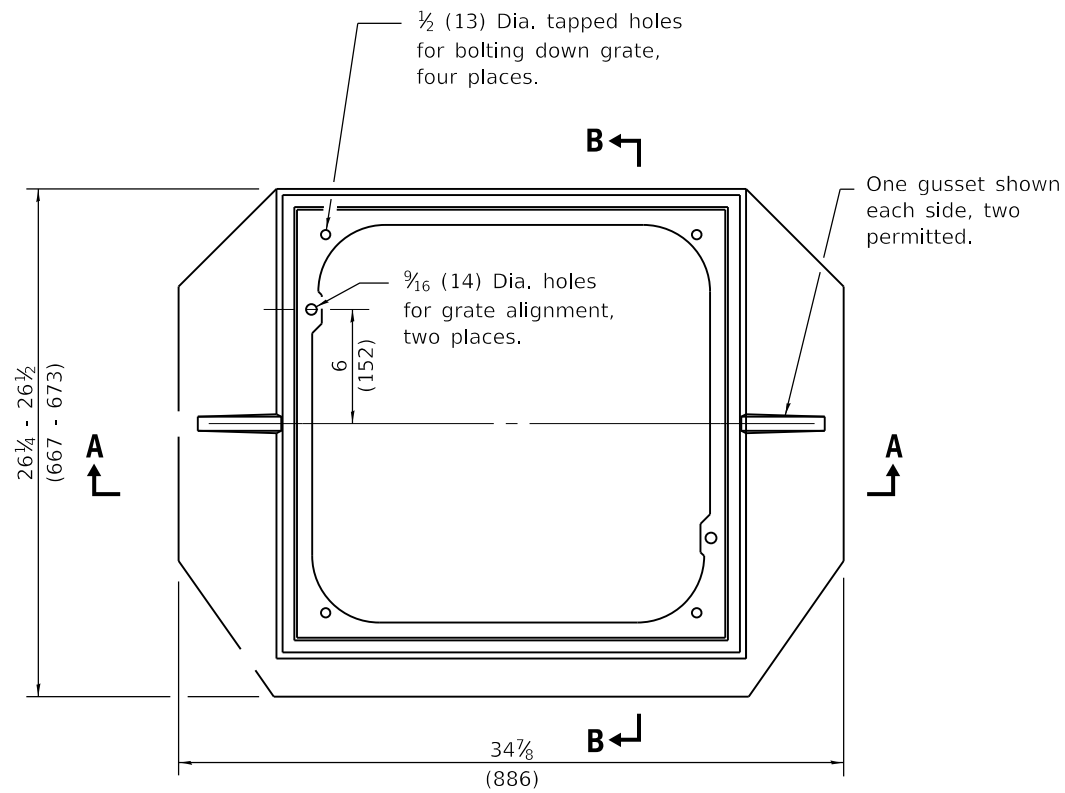

PLAN

CAST FRAME

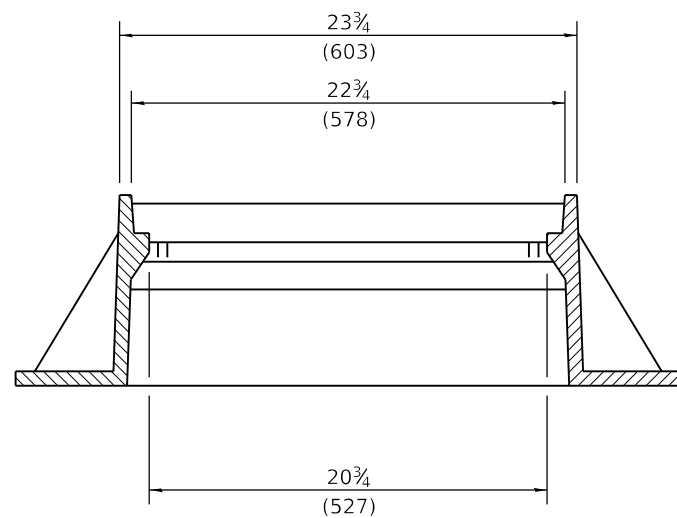

SECTION A-A

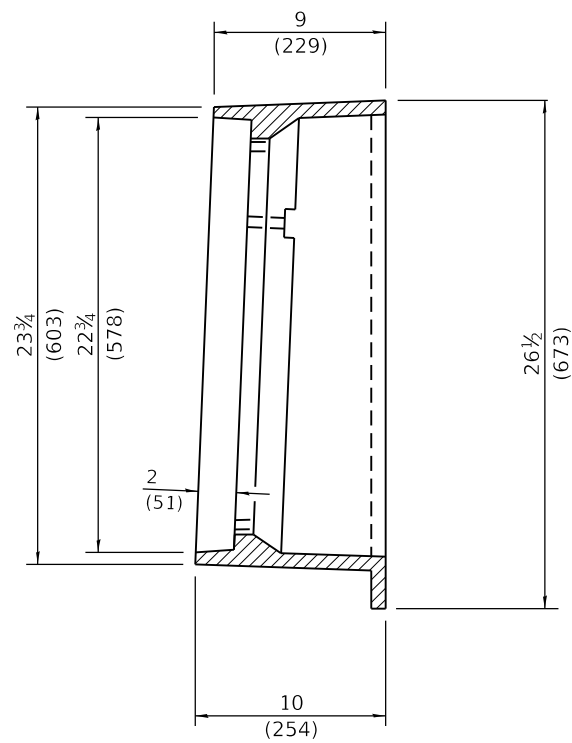

SECTION B-B

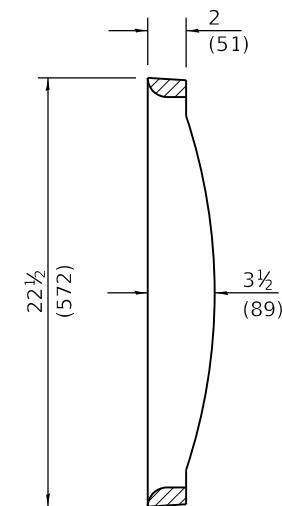

SECTION D-D

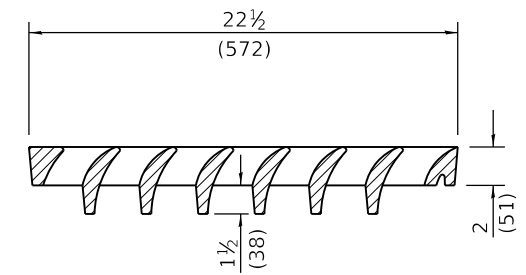

SECTION C-C

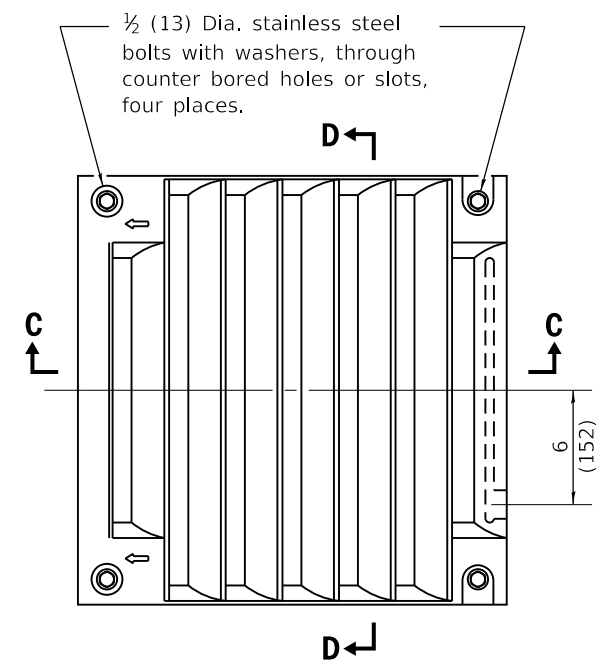

CAST GRATE

All dimensions are in inches (millimeters) unless otherwise shown.

DATE	REVISIONS
1-1-22	Removed slots in frame which held the "safety bar".
1-1-21	Removed "safety bar" from frame.

**FRAME AND GRATE
TYPE 20**

STANDARD 604071-07

Illinois Department of Transportation
 PASSED January 1, 2022
Michael Beard
 ENGINEER OF POLICY AND PROCEDURES
 APPROVED January 1, 2022
John C. ...
 ENGINEER OF DESIGN AND ENVIRONMENT

ISSUED 1-1-97

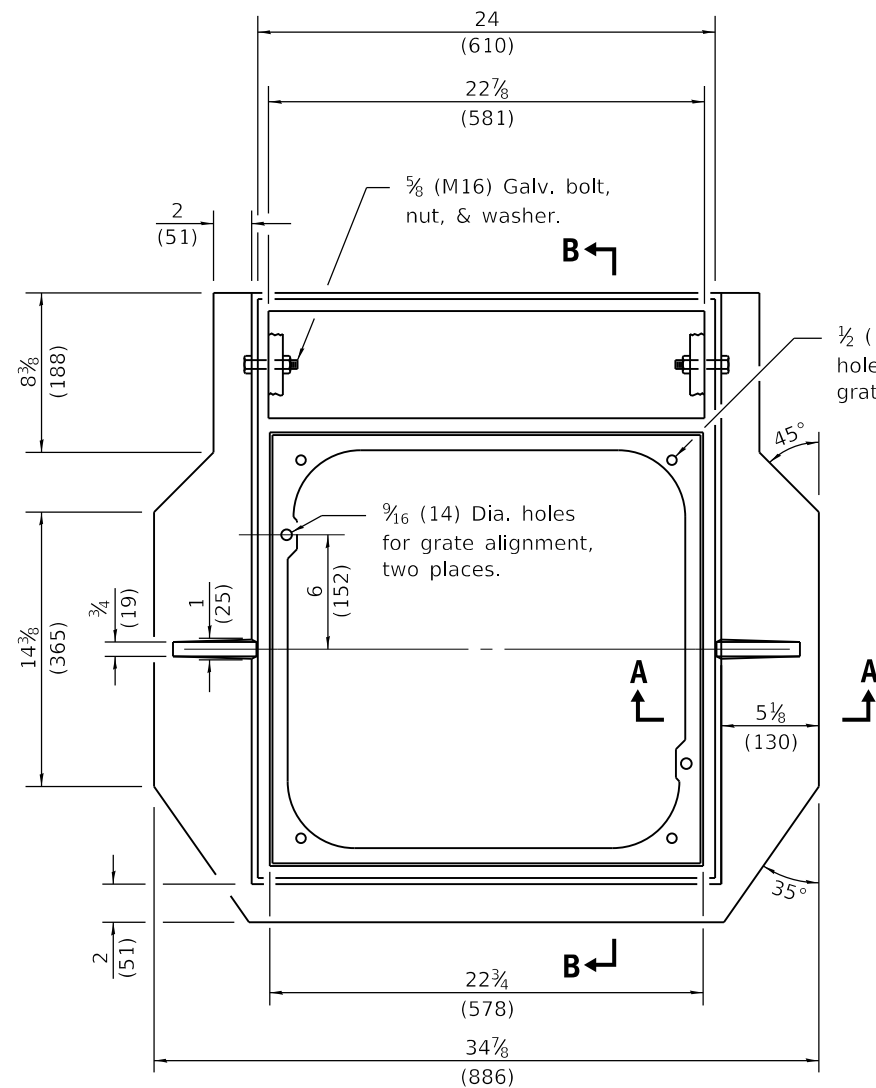

PLAN

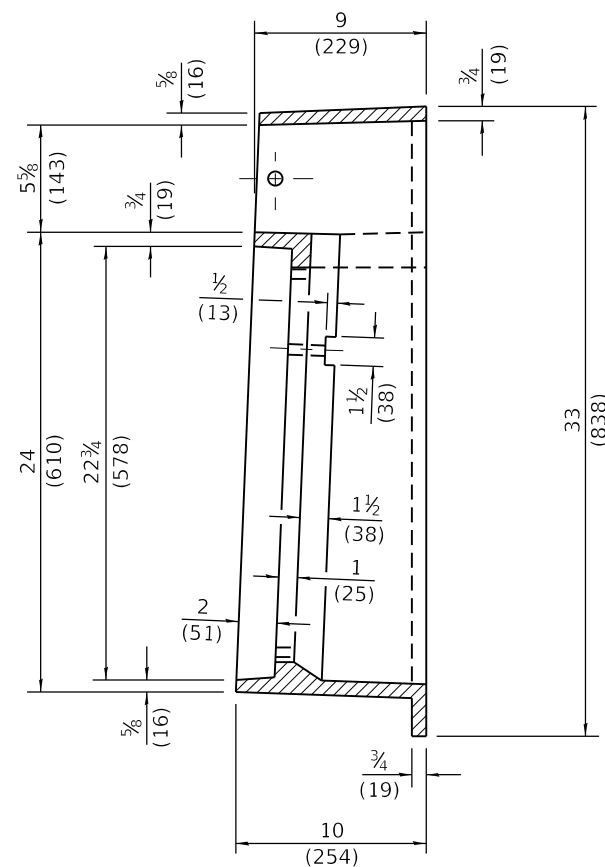

SECTION B-B

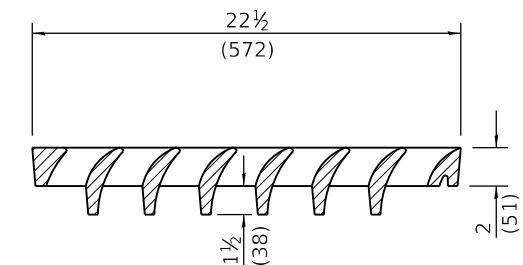

SECTION C-C

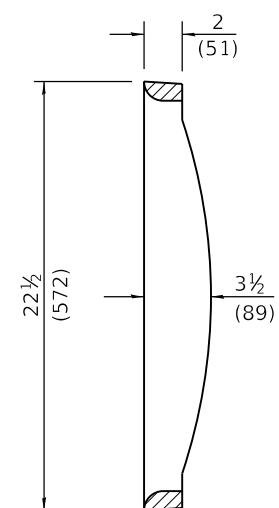

SECTION D-D

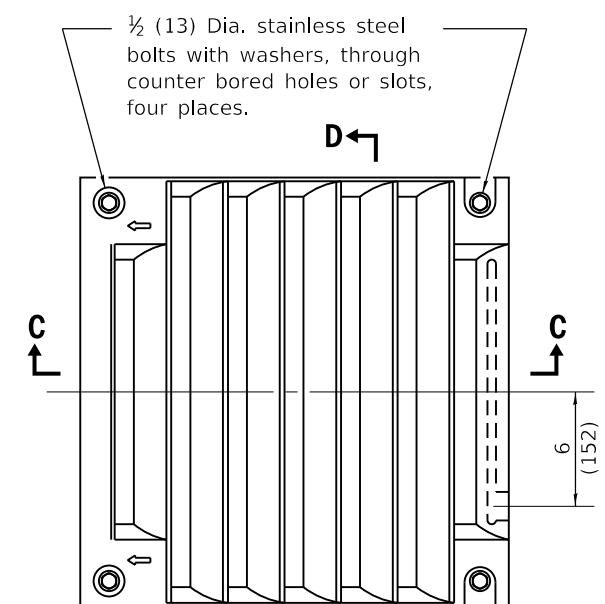

CAST GRATE

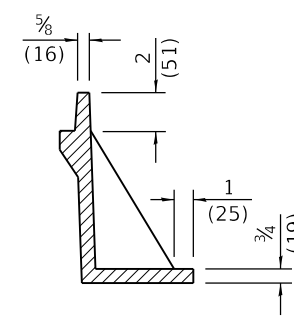

SECTION A-A

CAST FRAME

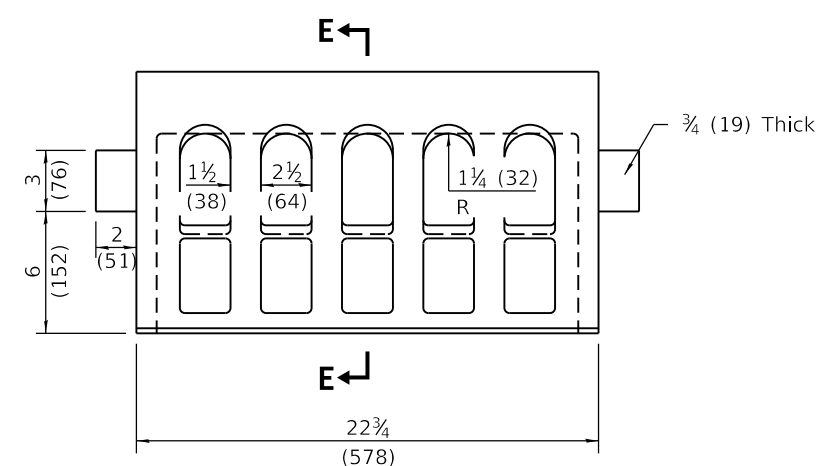

CURB BOX

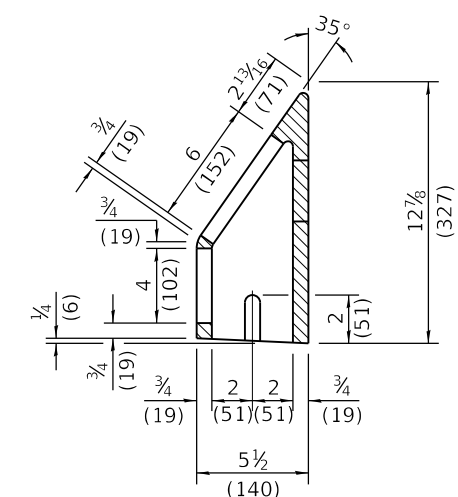

SECTION E-E

All dimensions are in inches (millimeters) unless otherwise shown.

DATE	REVISIONS
1-1-22	Removed slots in frame which held the "safety bar".
1-1-21	Removed "safety bar" from frame.

**FRAME AND GRATE
TYPE 21**

STANDARD 604076-06

Illinois Department of Transportation

PASSED January 1, 2022
Michael Beard
ENGINEER OF POLICY AND PROCEDURES

APPROVED January 1, 2022
John C. ...
ENGINEER OF DESIGN AND ENVIRONMENT

ISSUED 1-1-9
46-T

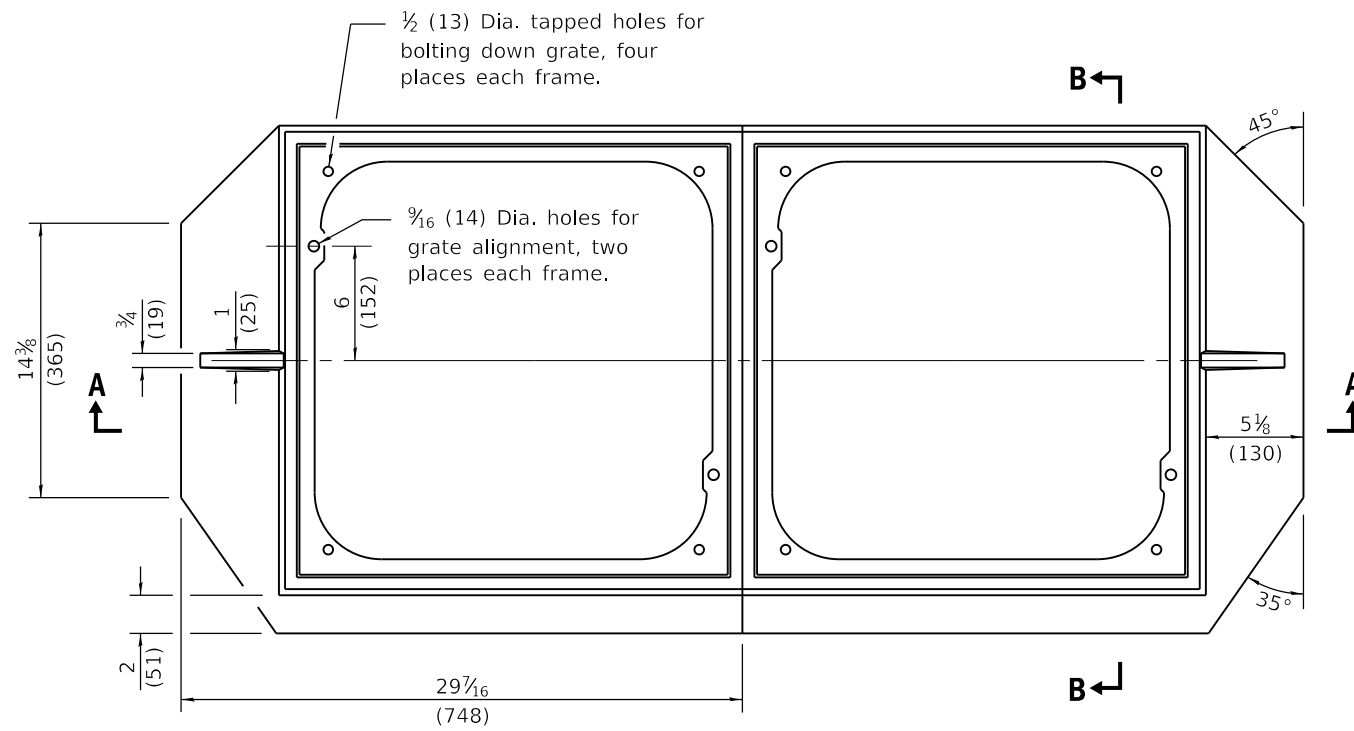

PLAN

CAST FRAME

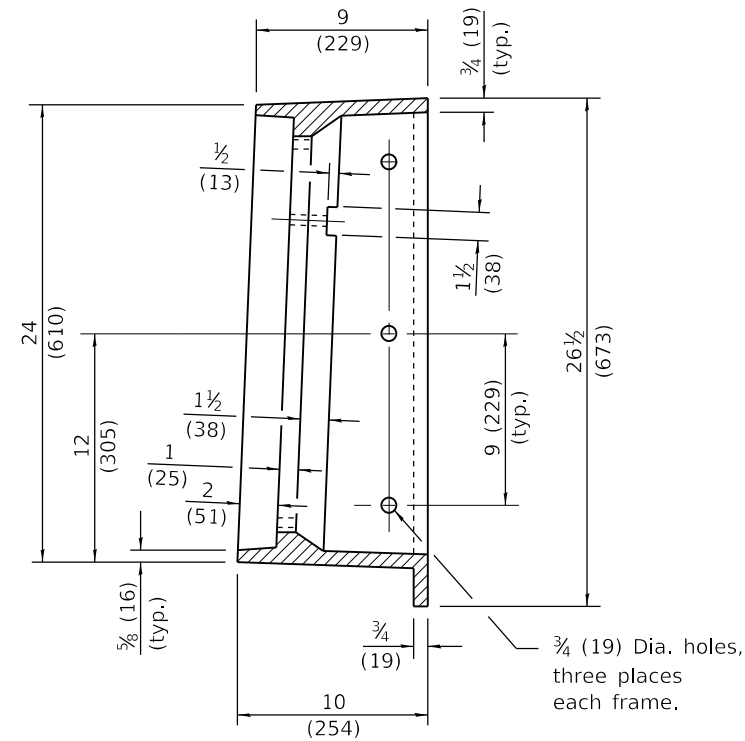

SECTION B-B

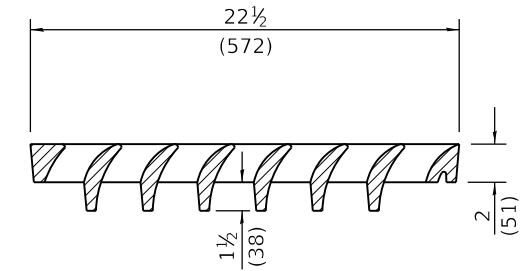

SECTION C-C

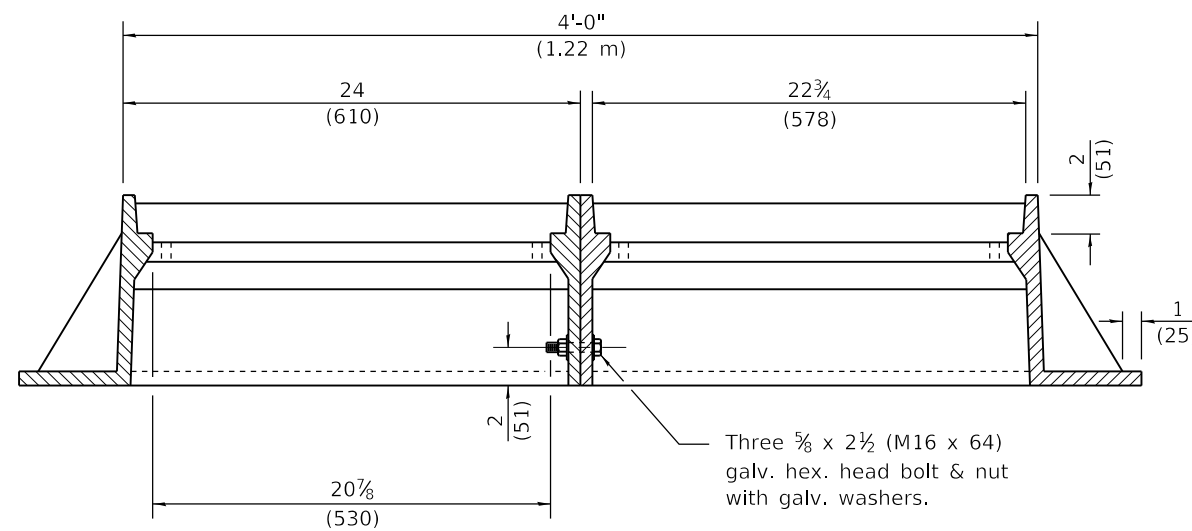

SECTION A-A

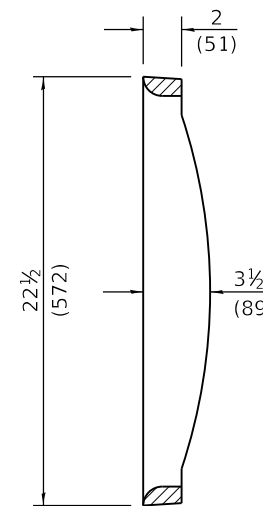

SECTION D-D

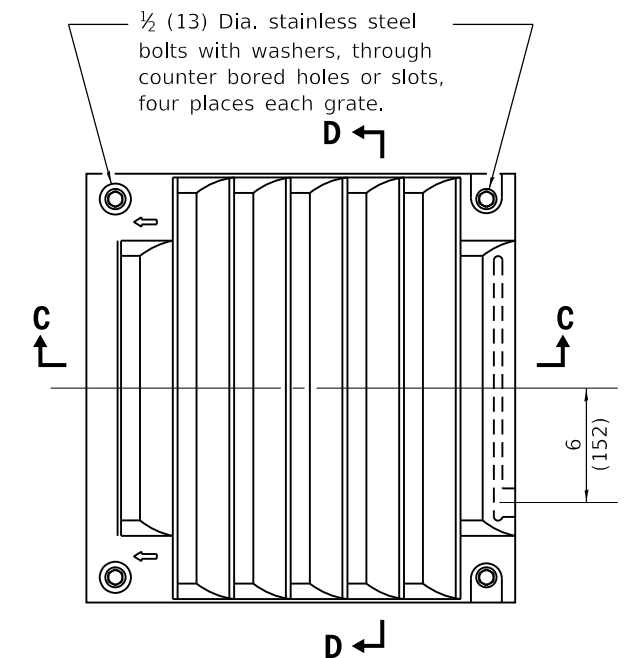

CAST GRATE

All dimensions are in inches (millimeters) unless otherwise shown.

Illinois Department of Transportation
 PASSED January 1, 2022
Michael Beard
 ENGINEER OF POLICY AND PROCEDURES
 APPROVED January 1, 2022
John C. ...
 ENGINEER OF DESIGN AND ENVIRONMENT
 ISSUED 1-1-97

DATE	REVISIONS
1-1-22	Removed slots in frame which held the "safety bar".
1-1-21	Removed "safety bar" from frame.

**FRAMES AND GRATES
TYPE 22**

STANDARD 604081-06

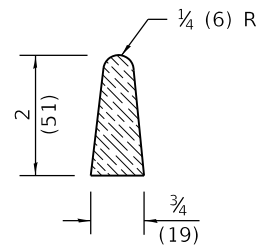

DETAIL A

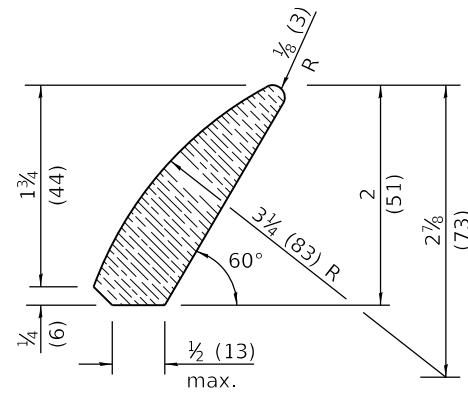

DETAIL B

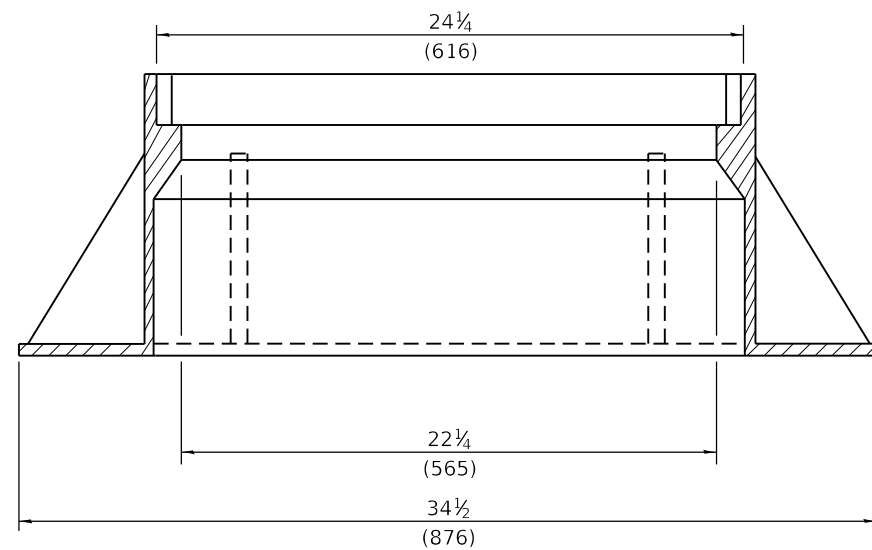

SECTION D-D

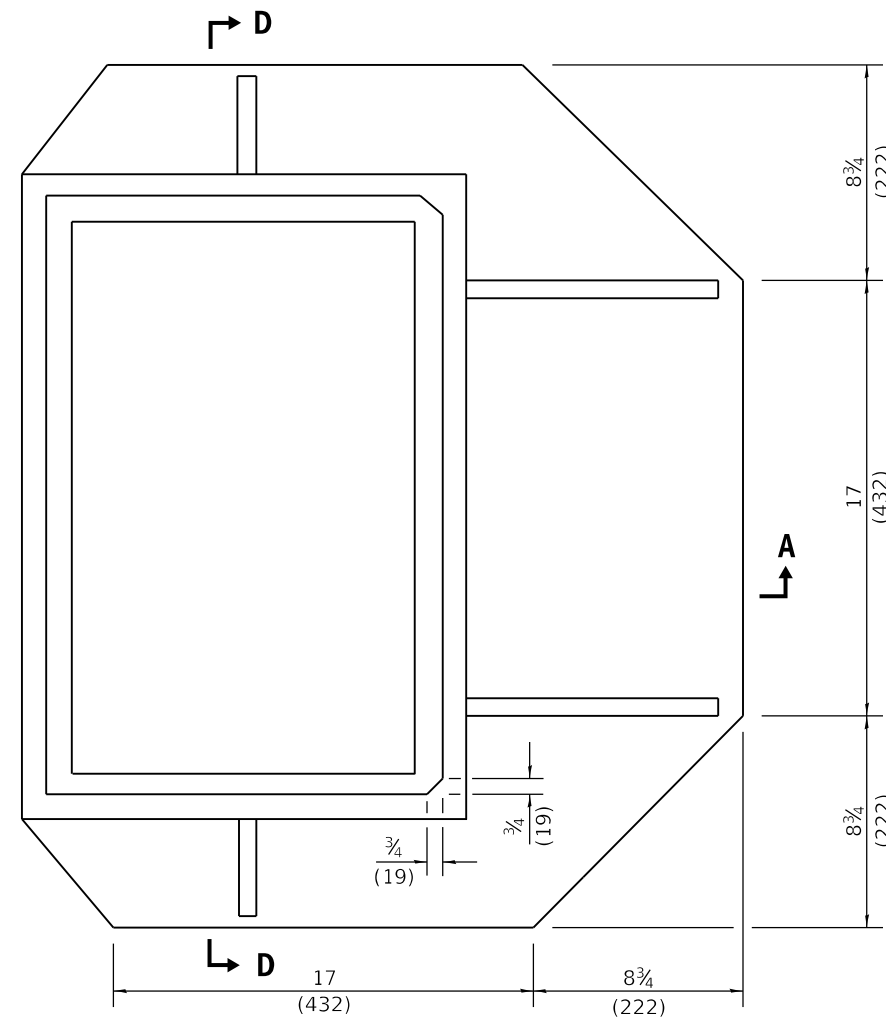

PLAN - FRAME

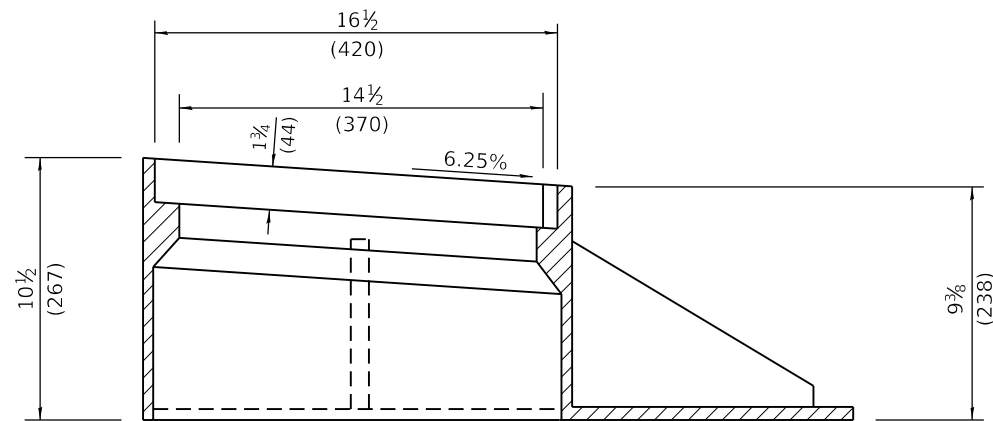

SECTION A-A

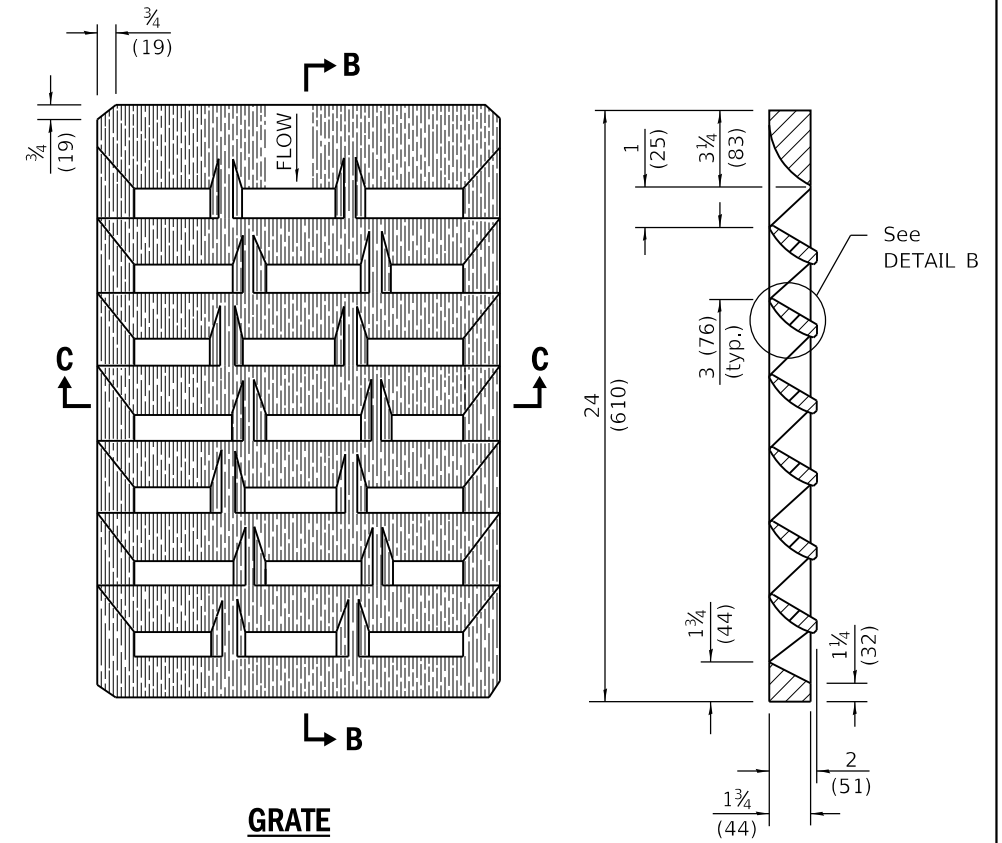

GRATE

SECTION B-B

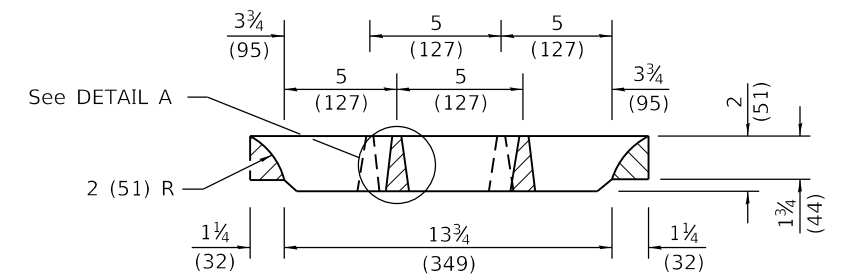

SECTION C-C

All dimensions are in inches (millimeters) unless otherwise shown.

Illinois Department of Transportation
 PASSED January 1, 2022
Michael Beard
 ENGINEER OF POLICY AND PROCEDURES
 APPROVED January 1, 2022
Seth Cline
 ENGINEER OF DESIGN AND ENVIRONMENT

ISSUED 1-1-22

DATE	REVISIONS
1-1-22	Removed slots in frame which held the "safety bars".
1-1-21	Removed "safety bars" from frame.

**FRAME AND GRATE
TYPE 23**

STANDARD 604086-05

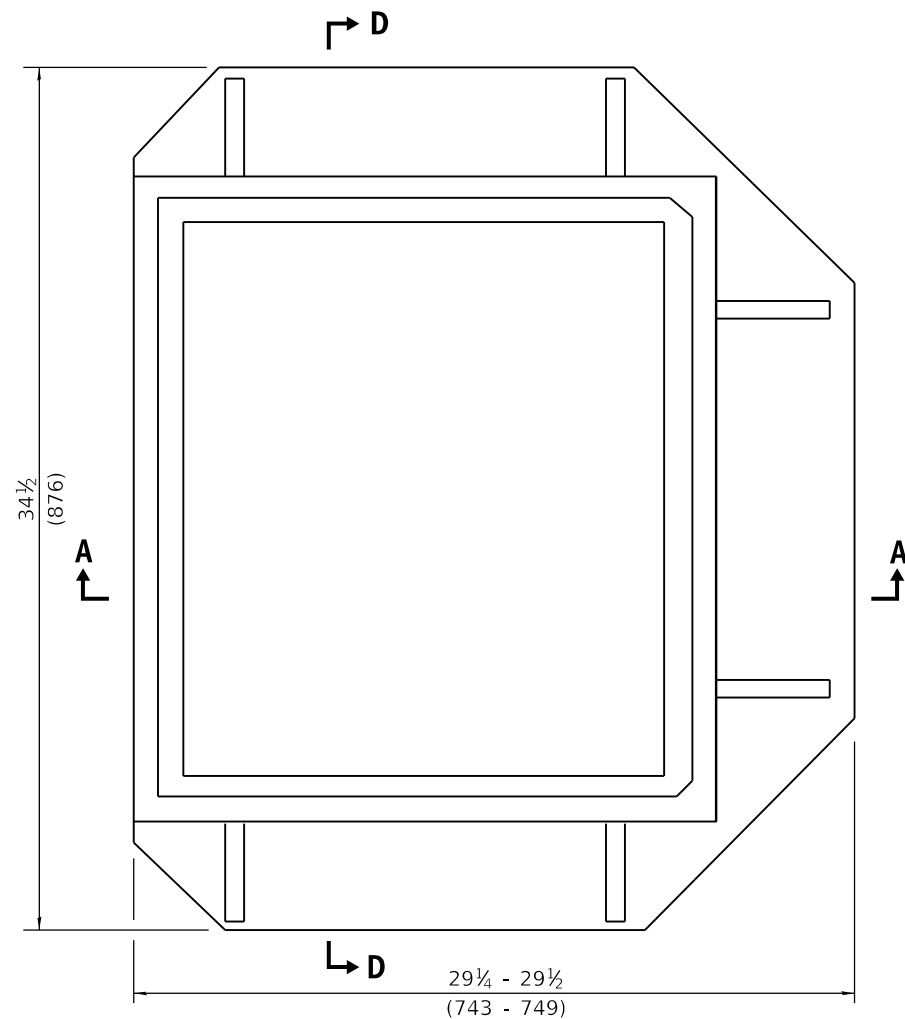

PLAN - FRAME

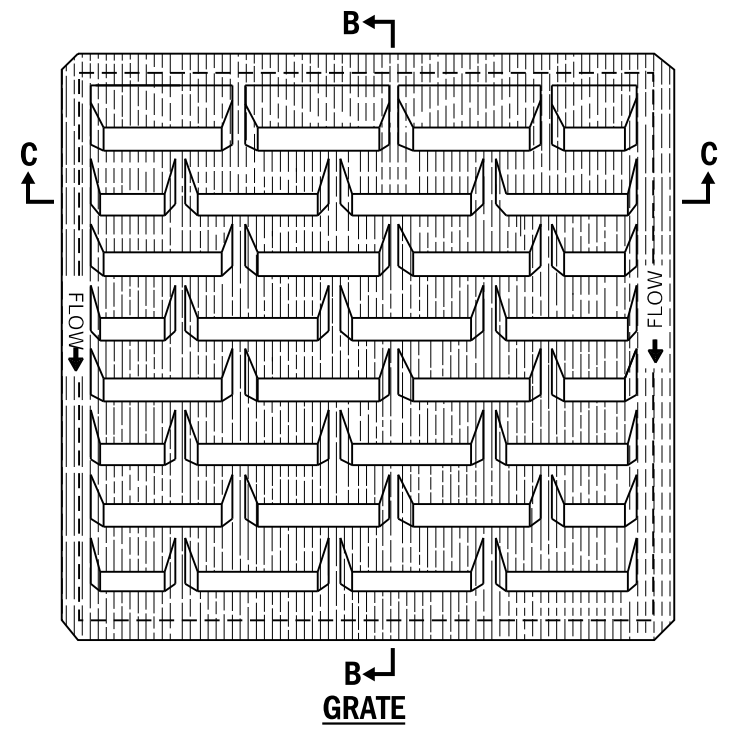

GRATE

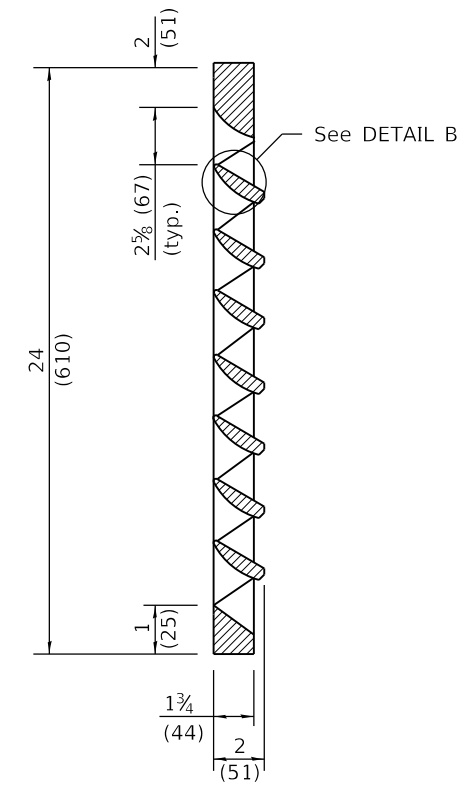

SECTION B-B

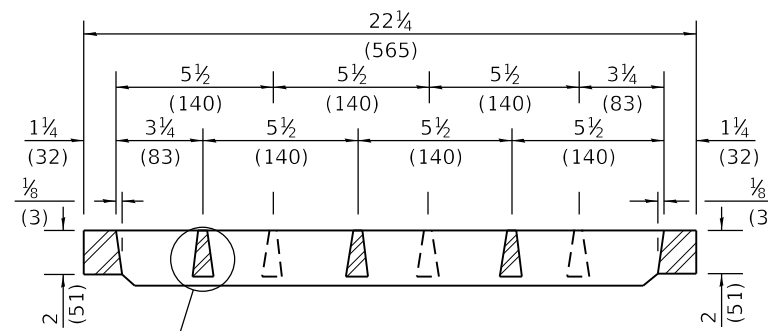

SECTION C-C

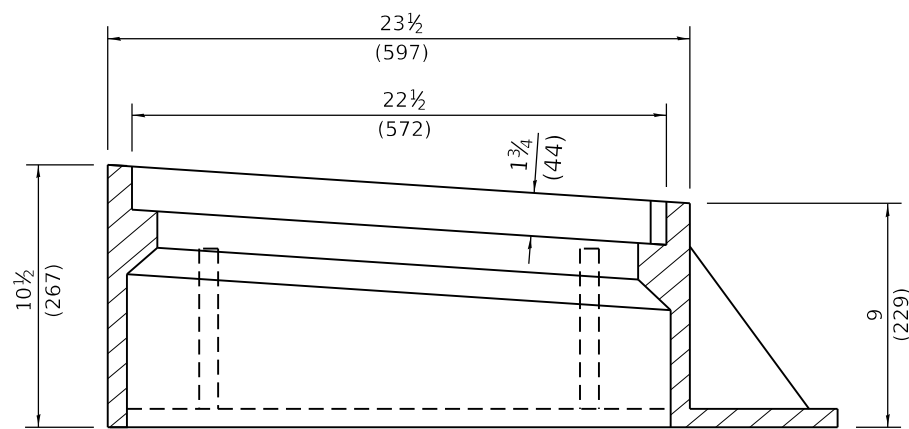

SECTION A-A

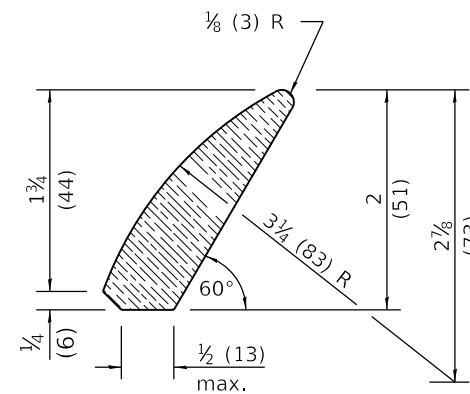

DETAIL B

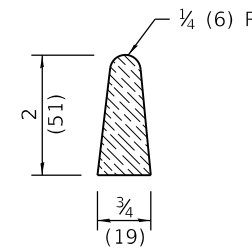

DETAIL A

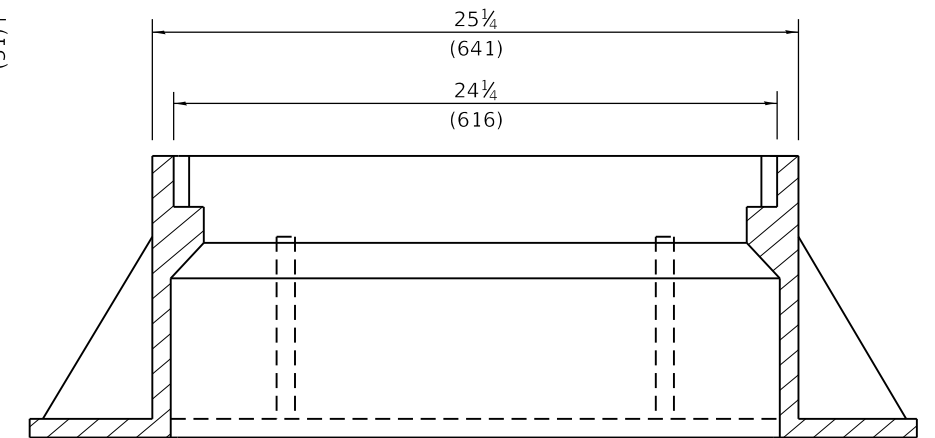

SECTION D-D

All dimensions are in inches (millimeters) unless otherwise shown.

Illinois Department of Transportation

PASSED January 1, 2022
Michael Beard
 ENGINEER OF POLICY AND PROCEDURES

APPROVED January 1, 2022
John C. ...
 ENGINEER OF DESIGN AND ENVIRONMENT

ISSUED 1-1-97

DATE	REVISIONS
1-1-22	Removed slots in frame which held the "safety bar".
1-1-21	Removed "safety bar" from frame.

**FRAME AND GRATE
TYPE 24**

STANDARD 604091-05

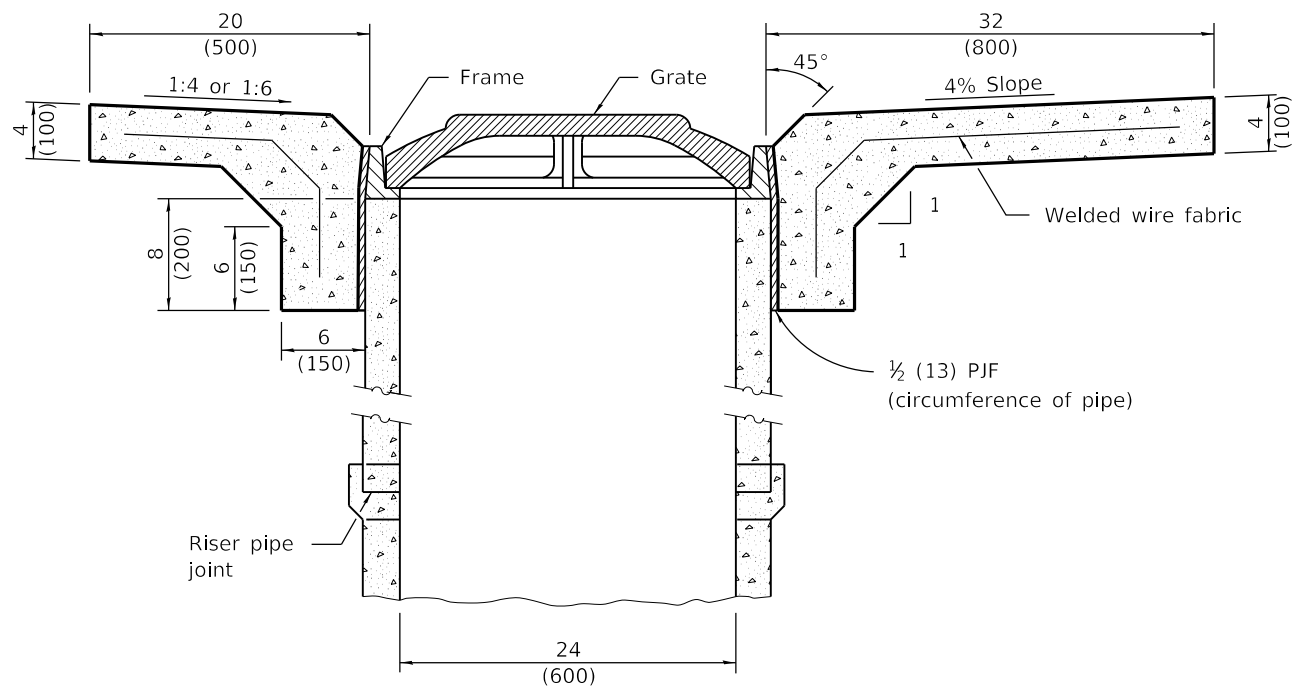

SECTION B-B

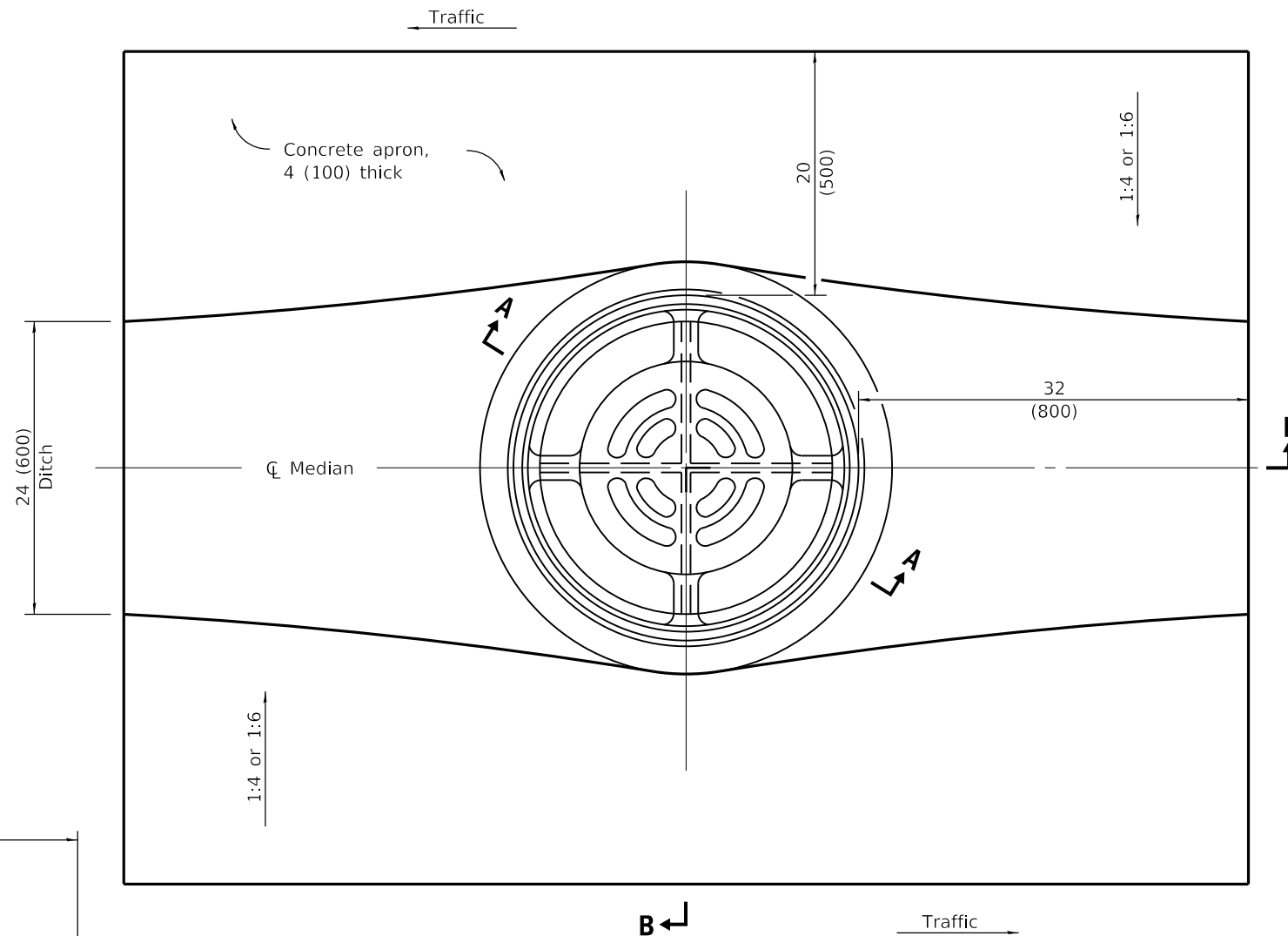

LOCATION SKETCH - PLAN

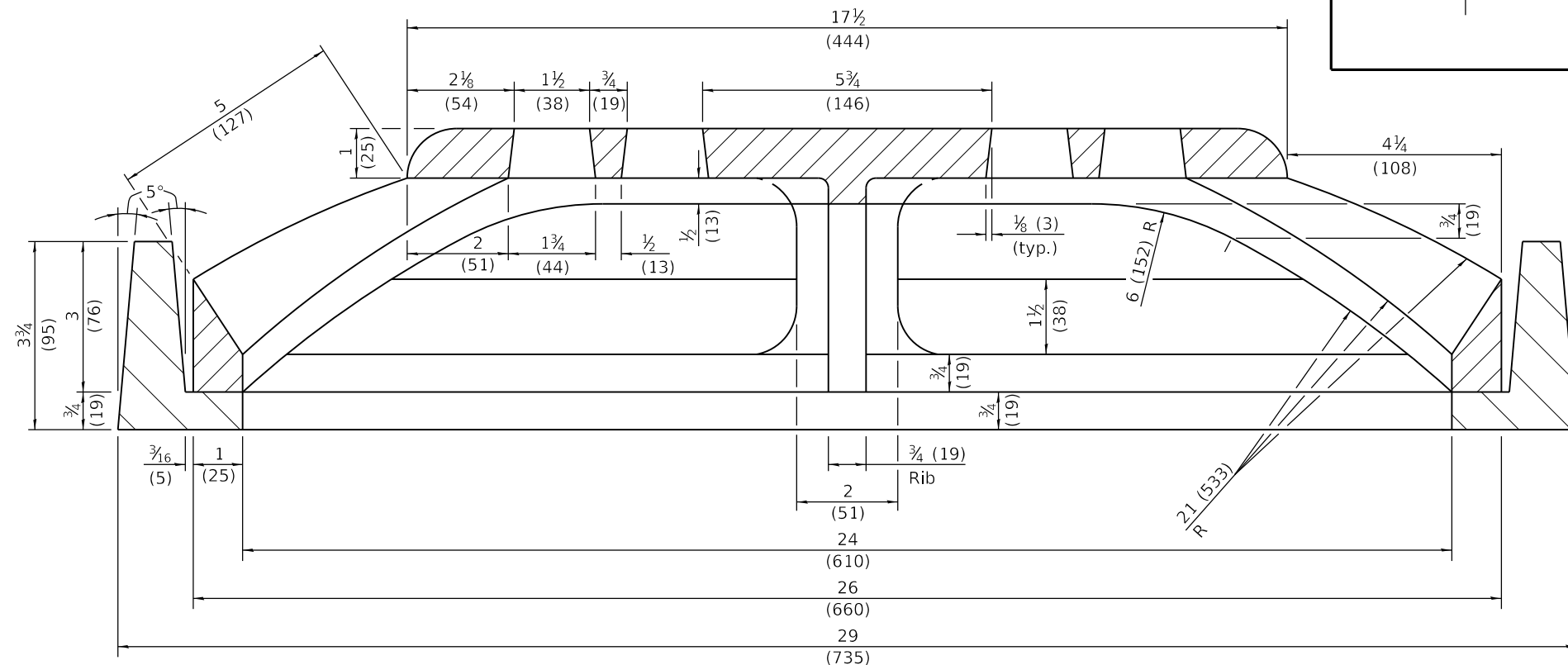

SECTION A-A

GENERAL NOTES
 All slope ratios are expressed as units of vertical displacement to units of horizontal displacement (V:H).

All dimensions are in inches (millimeters) unless otherwise shown.

DATE	REVISIONS
1-1-09	Switched units to English (metric).
1-1-97	Renum. Standard 2250-3.

**MEDIAN INLET for 24" (600 mm)
 REINFORCED CONCRETE PIPE**

STANDARD 604101-01

Illinois Department of Transportation

PASSED January 1, 2009
[Signature]
 ENGINEER OF POLICY AND PROCEDURES

APPROVED January 1, 2009
[Signature]
 ENGINEER OF DESIGN AND ENVIRONMENT

ISSUED 1-1-97

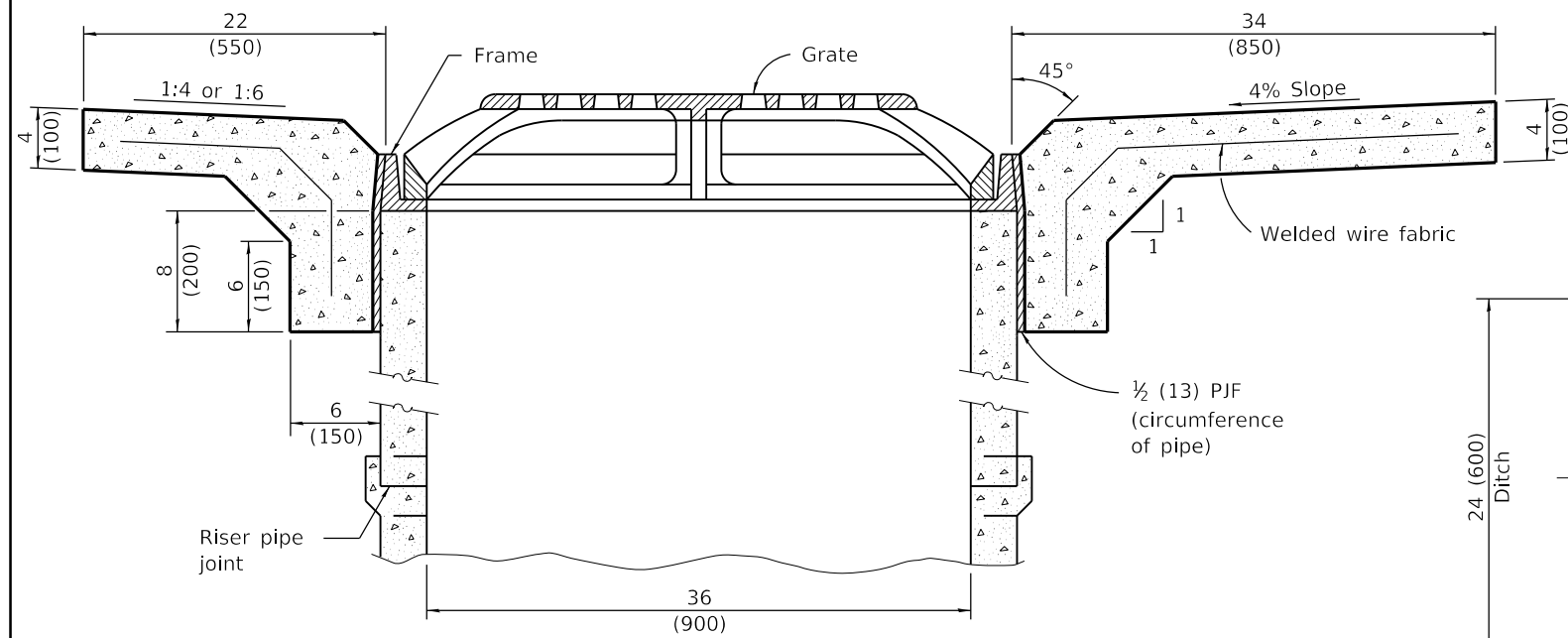

SECTION B-B

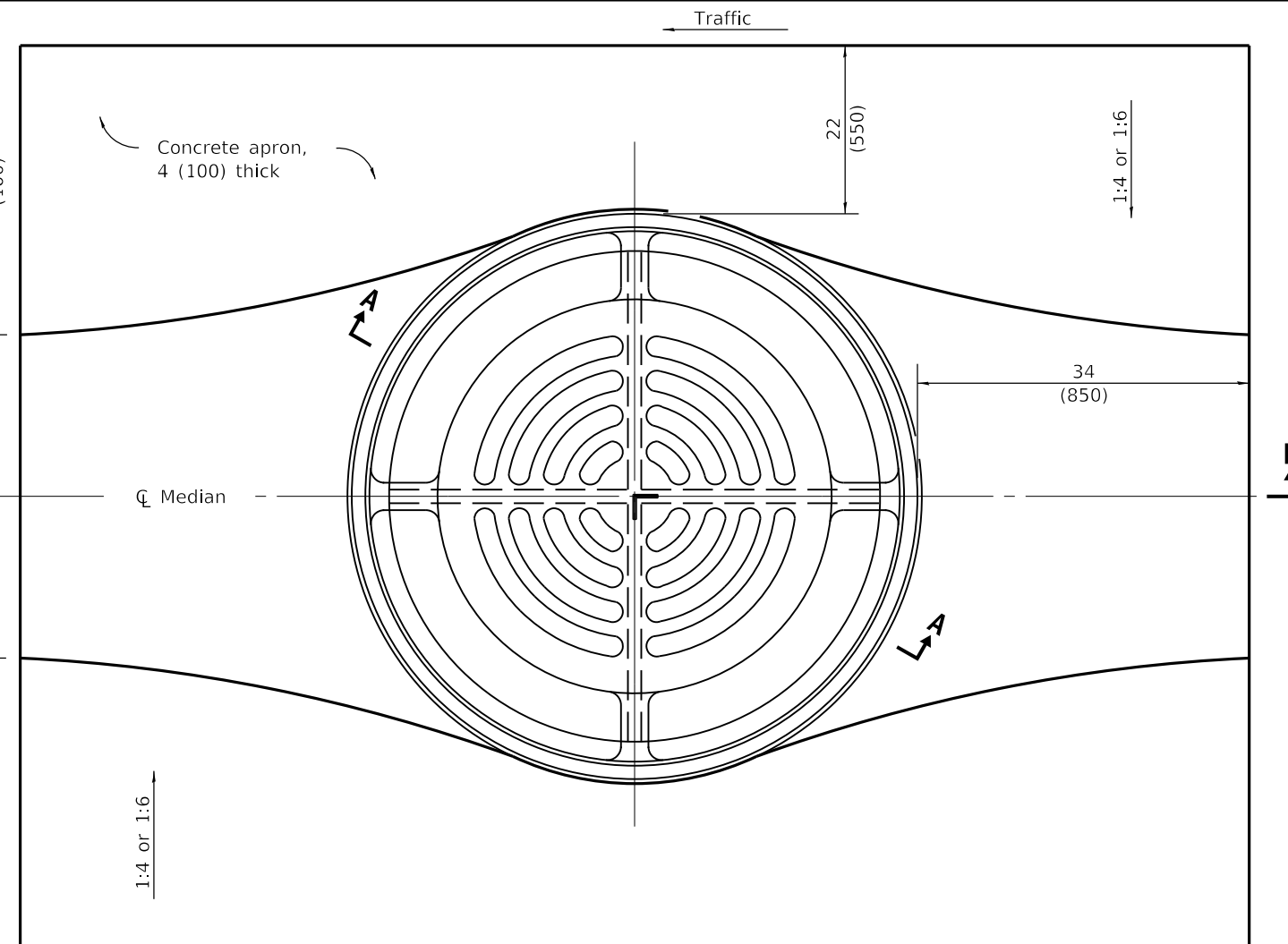

LOCATION SKETCH - PLAN

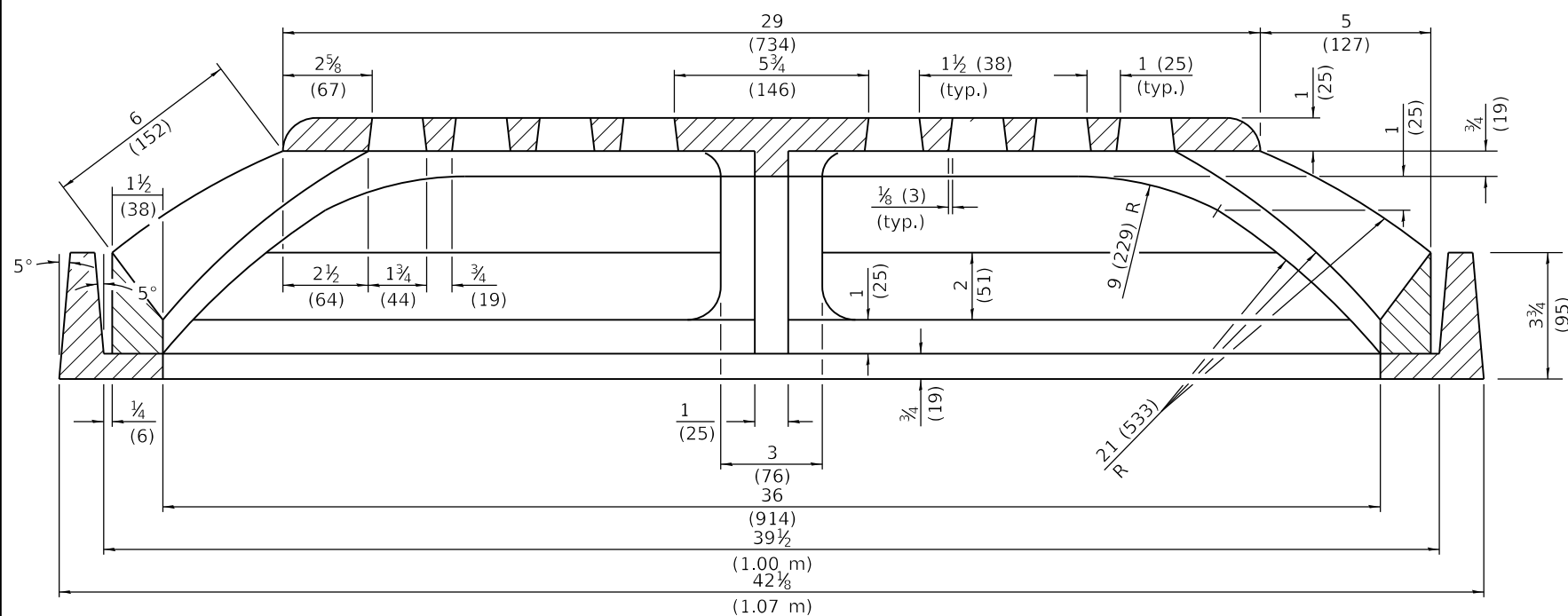

SECTION A-A

GENERAL NOTES
 All slope ratios are expressed as units of vertical displacement to units of horizontal displacement (V:H).

All dimensions are in inches (millimeters) unless otherwise shown.

DATE	REVISIONS
1-1-09	Switched units to English (metric).
1-1-97	Renum. Standard 2251-2.

**MEDIAN INLET for 36" (900 mm)
 REINFORCED CONCRETE PIPE**

STANDARD 604106-01

Illinois Department of Transportation

PASSED January 1, 2009
Scott Smith
 ENGINEER OF POLICY AND PROCEDURES

APPROVED January 1, 2009
Ken E. Han
 ENGINEER OF DESIGN AND ENVIRONMENT

ISSUED 1-1-97

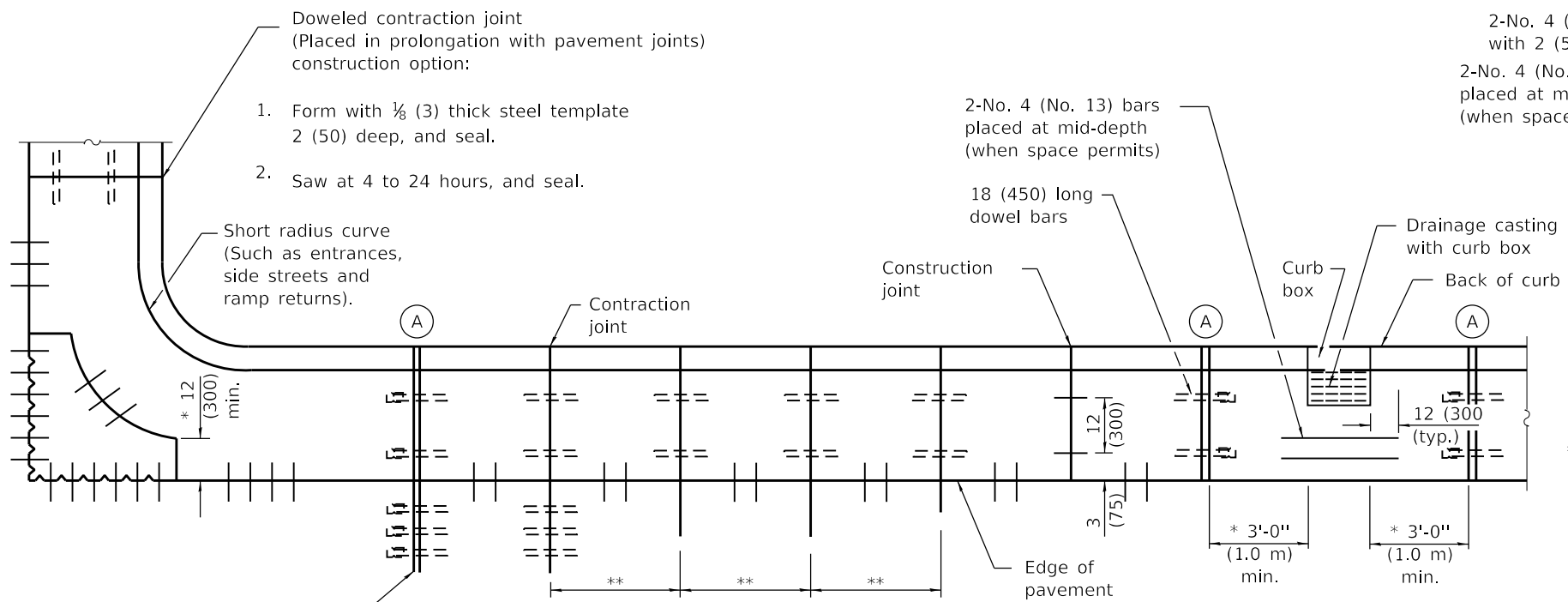

PLAN
ADJACENT TO PCC PAVEMENT OR PCC BASE COURSE

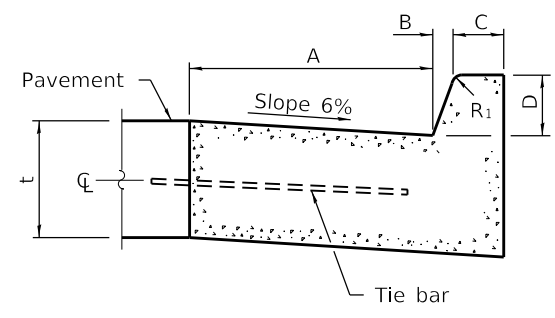

BARRIER CURB

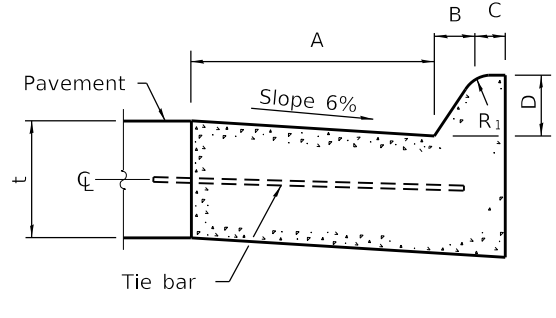

MOUNTABLE CURB

TABLE OF DIMENSIONS BARRIER CURB					
TYPE	A	B	C	D	R ₁
B-6.06 *	6	1	6	6	1
(B-15.15)	(150)	(25)	(150)	(150)	(25)
B-6.12	12	1	6	6	1
(B-15.3)	(300)	(25)	(150)	(150)	(25)
B-6.18	18	1	6	6	1
(B-15.45)	(450)	(25)	(150)	(150)	(25)
B-6.24	24	1	6	6	1
(B-15.60)	(600)	(25)	(150)	(150)	(25)
B-9.12	12	2	5	9	1
(B-22.30)	(300)	(50)	(125)	(225)	(25)
B-9.18	18	2	5	9	1
(B-22.45)	(450)	(50)	(125)	(225)	(25)
B-9.24	24	2	5	9	1
(B-22.60)	(600)	(50)	(125)	(225)	(25)

* For corner islands only.

TABLE OF DIMENSIONS MOUNTABLE CURB						
TYPE	A	B	C	D	R ₁	R ₂
M-2.06	6	2	4	2	3	2
(M-5.15)	(150)	(50)	(100)	(50)	(75)	(50)
M-2.12	12	2	4	2	3	2
(M-5.30)	(300)	(50)	(100)	(50)	(75)	(50)
M-4.06	6	4	3	4	3	NA
(M-10.15)	(150)	(100)	(75)	(100)	(75)	NA
M-4.12	12	4	3	4	3	NA
(M-10.30)	(300)	(100)	(75)	(100)	(75)	NA
M-4.18	18	4	3	4	3	NA
(M-10.45)	(450)	(100)	(75)	(100)	(75)	NA
M-4.24	24	4	3	4	3	NA
(M-10.60)	(600)	(100)	(75)	(100)	(75)	NA
M-6.06	6	6	2	6	2	NA
(M-15.15)	(150)	(150)	(50)	(150)	(50)	NA
M-6.12	12	6	2	6	2	NA
(M-15.30)	(300)	(150)	(50)	(150)	(50)	NA
M-6.18	18	6	2	6	2	NA
(M-15.45)	(450)	(150)	(50)	(150)	(50)	NA
M-6.24	24	6	2	6	2	NA
(M-15.60)	(600)	(150)	(50)	(150)	(50)	NA

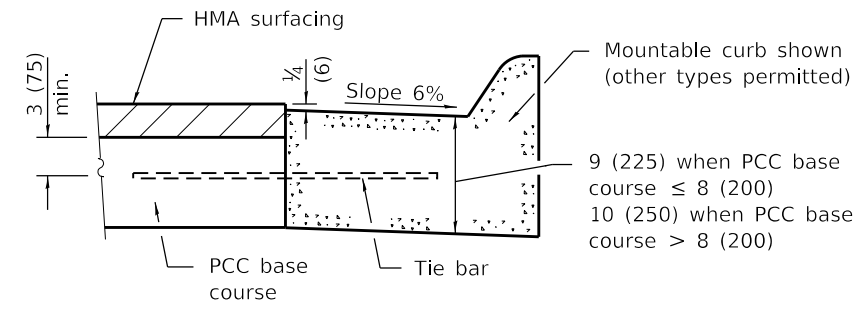

ADJACENT TO PCC BASE COURSE WITH HMA SURFACING

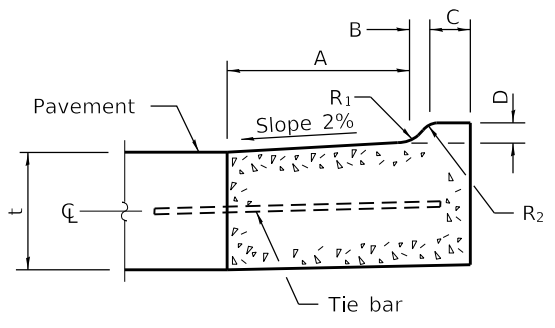

M-2.06 (M-5.15) and M-2.12 (M-5.30)

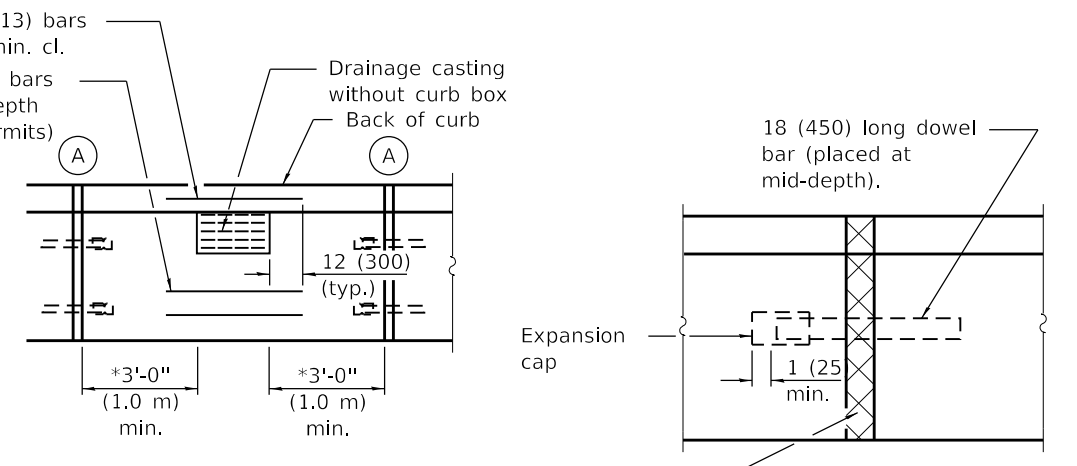

DETAIL A
EXPANSION JOINT

Full depth & width 1 (25) - thick (min.) preformed expansion joint filler.

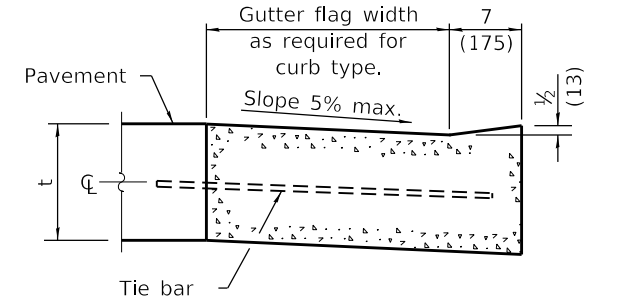

DEPRESSED CURB ADJACENT TO CURB RAMP ACCESSIBLE TO THE DISABLED

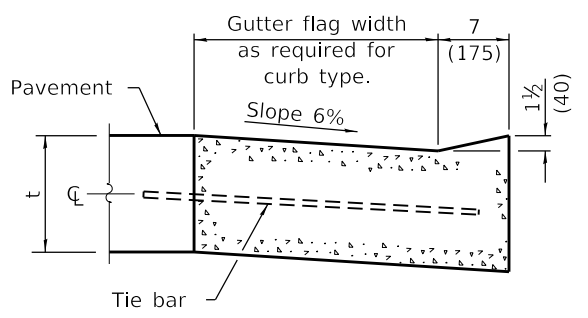

DEPRESSED CURB (TYPICAL)

GENERAL NOTES

The bottom slope of combination curb and gutter constructed adjacent to pcc pavement shall be the same slope as the subbase or 6% when subbase is omitted.

t = Thickness of pavement.

Longitudinal joint tie bars shall be No. 6 (No. 19) at 36 (900) centers in accordance with details for longitudinal construction joint shown on Standard 420001.

A minimum clearance of 2 (50) between the end of the tie bar and the back of the curb shall be maintained.

The dowel bars shown in contraction joints will only be required for monolithic construction.

See Standard 606301 for details of corner islands.

All dimensions are in inches (millimeters) unless otherwise shown.

DATE	REVISIONS
1-1-22	Revised contraction joint spacing adjacent to pcc pavement.
1-1-18	Revised General Note for tie bar spacing to 36 (900) cts.

CONCRETE CURB TYPE B AND COMBINATION CONCRETE CURB AND GUTTER
(Sheet 1 of 2)

STANDARD 606001-08

Illinois Department of Transportation

PASSED January 1, 2022

Michael Brand
ENGINEER OF POLICY AND PROCEDURES

APPROVED January 1, 2022

ENGINEER OF DESIGN AND ENVIRONMENT

ISSUED 1-1-97

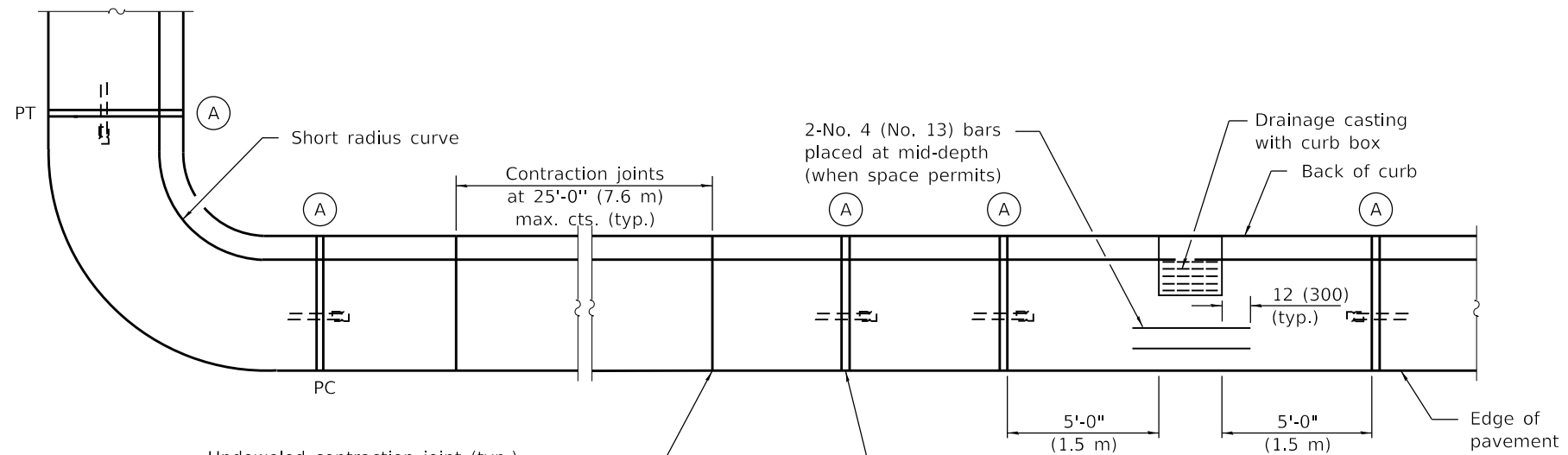

Undoweled contraction joint (typ.) construction options:

1. Form with 1/8 (3) thick steel template 2 (50) deep, and seal.
2. Saw 2 (50) deep at 4 to 24 hours, and seal.
3. Insert 3/4 (20) thick preformed joint filler full depth and width.

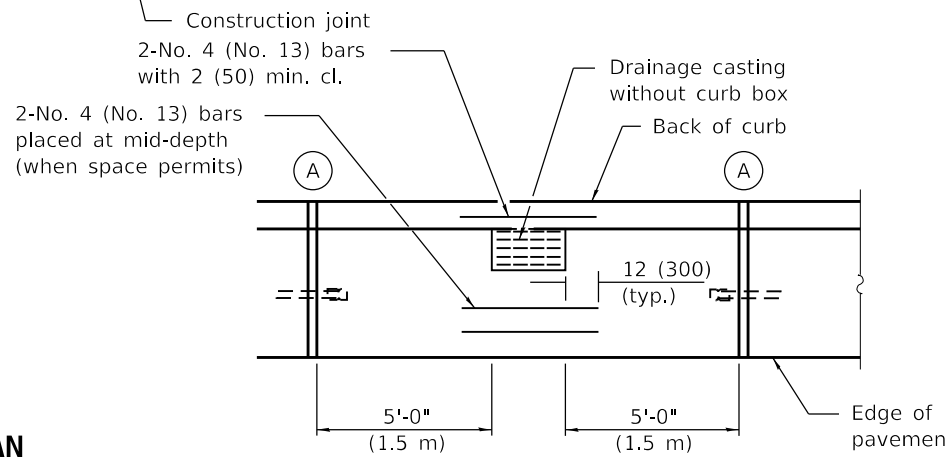

PLAN

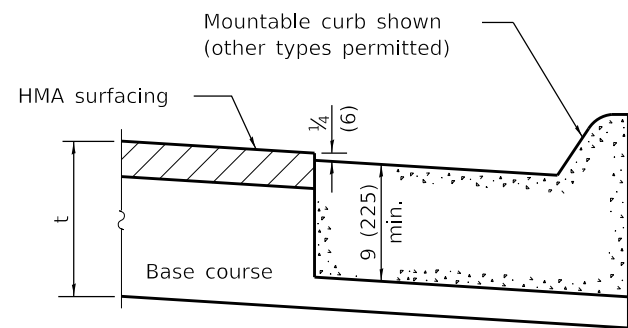

ON DISTURBED SUBGRADE

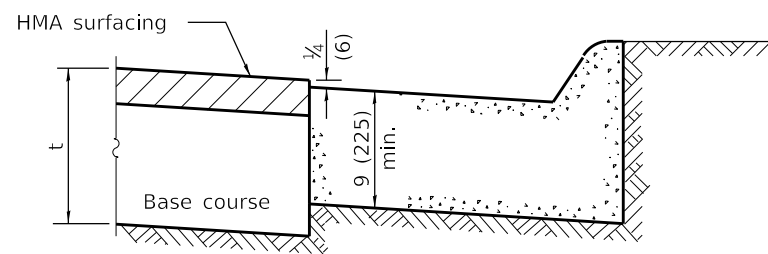

ON UNDISTURBED SUBGRADE

ADJACENT TO FLEXIBLE PAVEMENT

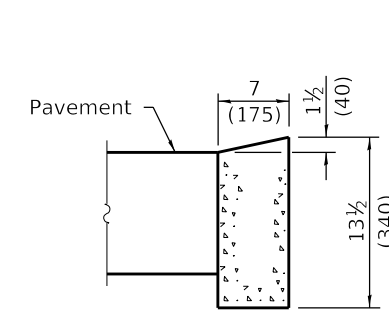

DEPRESSED CURB

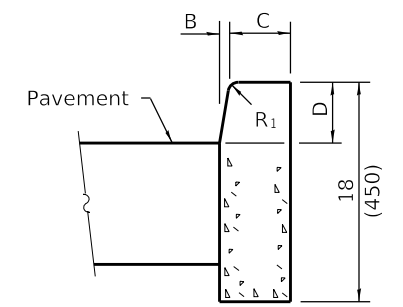

BARRIER CURB

ADJACENT TO FLEXIBLE PAVEMENT

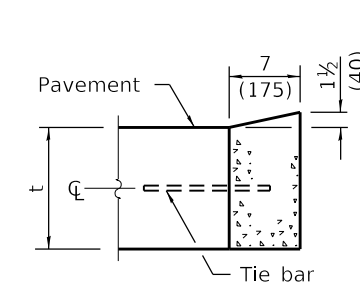

DEPRESSED CURB

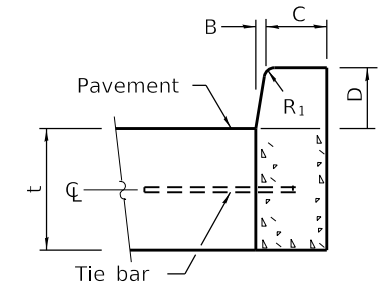

BARRIER CURB

ADJACENT TO PCC PAVEMENT OR PCC BASE COURSE

CONCRETE CURB TYPE B

**CONCRETE CURB TYPE B
AND COMBINATION
CONCRETE CURB AND GUTTER**

(Sheet 2 of 2)

STANDARD 606001-08

Illinois Department of Transportation

PASSED January 1, 2022
Michael Beard
 ENGINEER OF POLICY AND PROCEDURES

APPROVED January 1, 2022
John C. ...
 ENGINEER OF DESIGN AND ENVIRONMENT

ISSUED 1-1-97

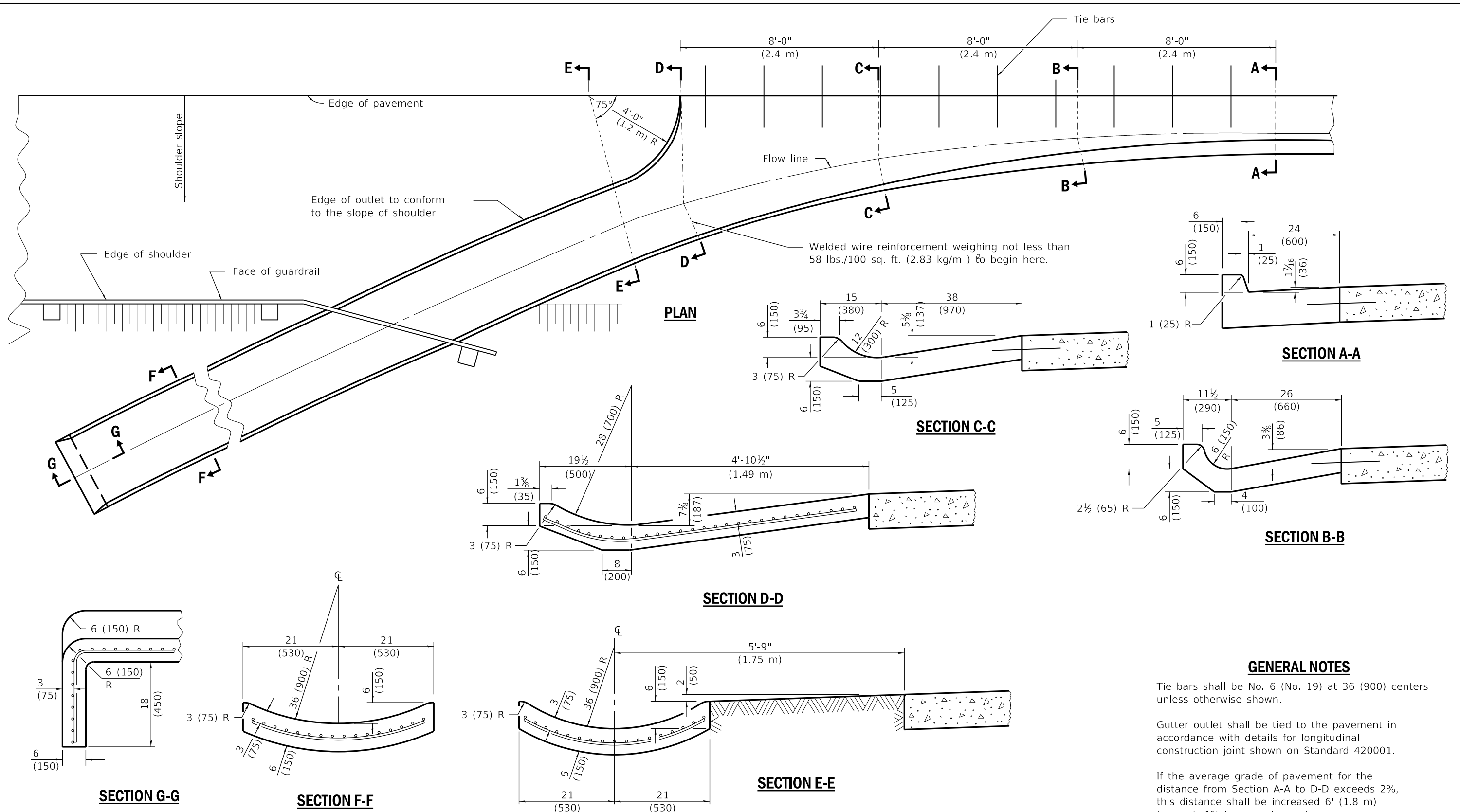

Welded wire reinforcement weighing not less than 58 lbs./100 sq. ft. (2.83 kg/m²) to begin here.

GENERAL NOTES

Tie bars shall be No. 6 (No. 19) at 36 (900) centers unless otherwise shown.

Gutter outlet shall be tied to the pavement in accordance with details for longitudinal construction joint shown on Standard 420001.

If the average grade of pavement for the distance from Section A-A to D-D exceeds 2%, this distance shall be increased 6' (1.8 m) for each 1% increase in grade.

All dimensions are in inches (millimeters) unless otherwise shown.

QUANTITIES

For Section A-A to E-E and curtain wall =
 2.38 cu. yds. (1.82 m³) concrete for 9 (225) pav't.
 2.41 cu. yds. (1.84 m³) concrete for 10 (250) pav't.
 For Section F-F =
 0.069 cu. yds. (0.17 m³) concrete per ft. (m)

STANDARD OUTLET

DATE	REVISIONS
1-1-18	Revised General Notes for tie bar spacing to 36 (900) cts.
4-1-16	Changed terminology to 'welded wire reinforcement'.

OUTLETS FOR CONCRETE CURB AND GUTTER TYPE B-6.24 (B-15.60)
 (Sheet 1 of 2)
STANDARD 606006-04

Illinois Department of Transportation
 PASSED January 1, 2018
 Michael Beard
 ENGINEER OF POLICY AND PROCEDURES
 APPROVED January 1, 2018
 Matthew M. Adams
 ENGINEER OF DESIGN AND ENVIRONMENT
 ISSUED 1-1-97

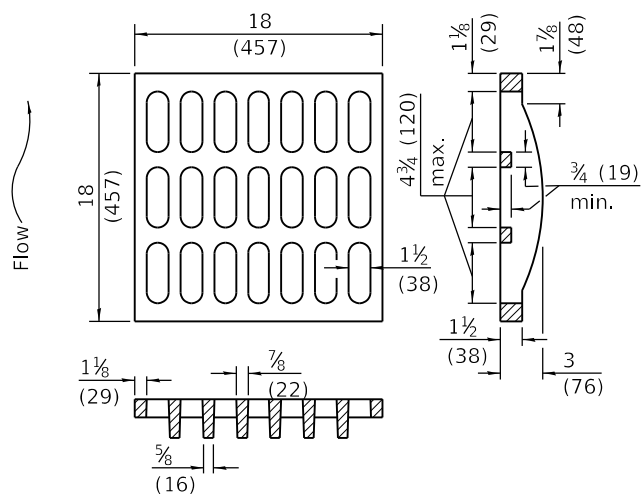

GRATE TYPE A

QUANTITIES

1.98 cu. yds. (1.51 m³) concrete for 9 (225) pav't.

2.01 cu. yds. (1.54 m³) concrete for 10 (250) pav't.

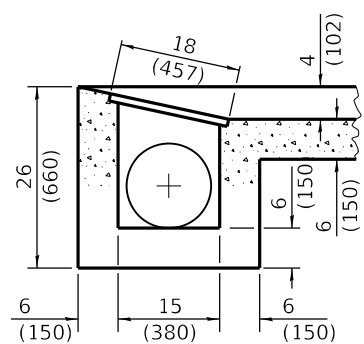

SECTION E-E

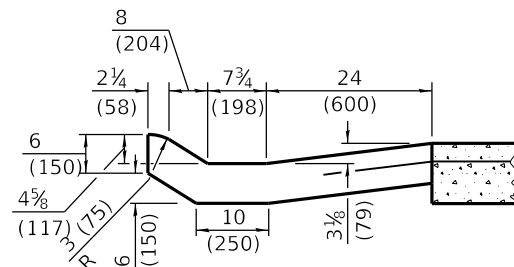

SECTION C-C

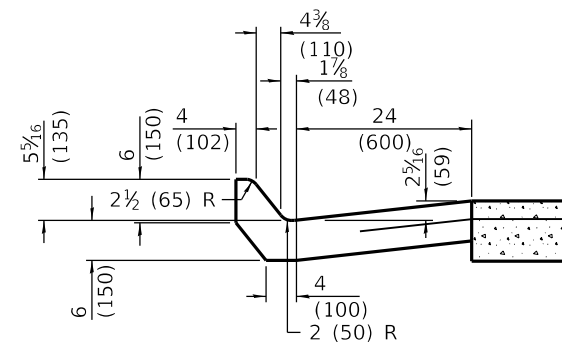

SECTION B-B

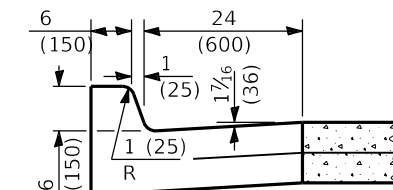

SECTION A-A

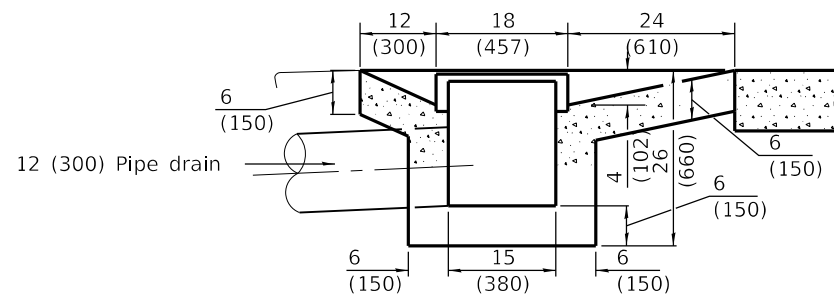

SECTION D-D

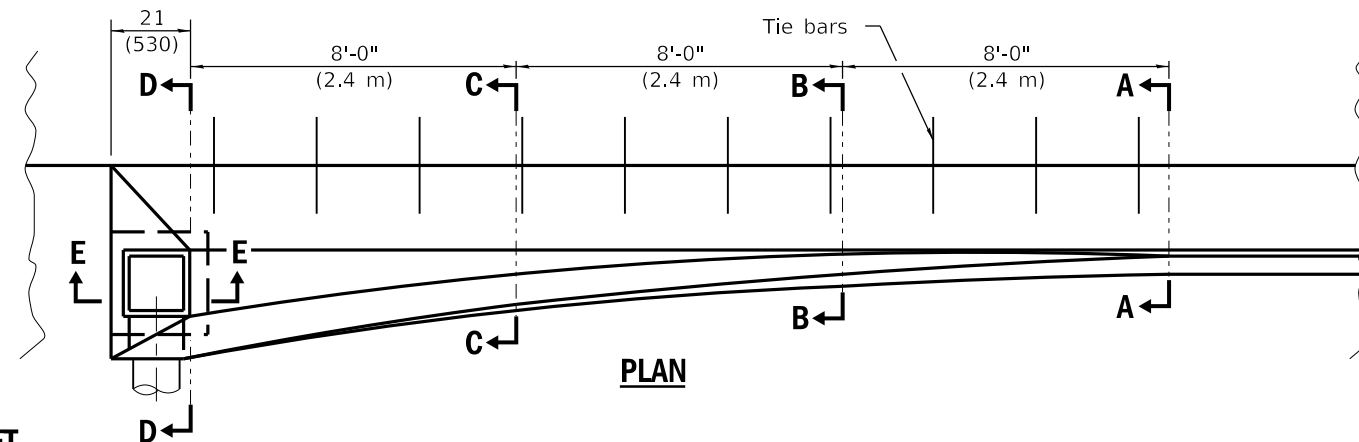

TYPE 1 OUTLET

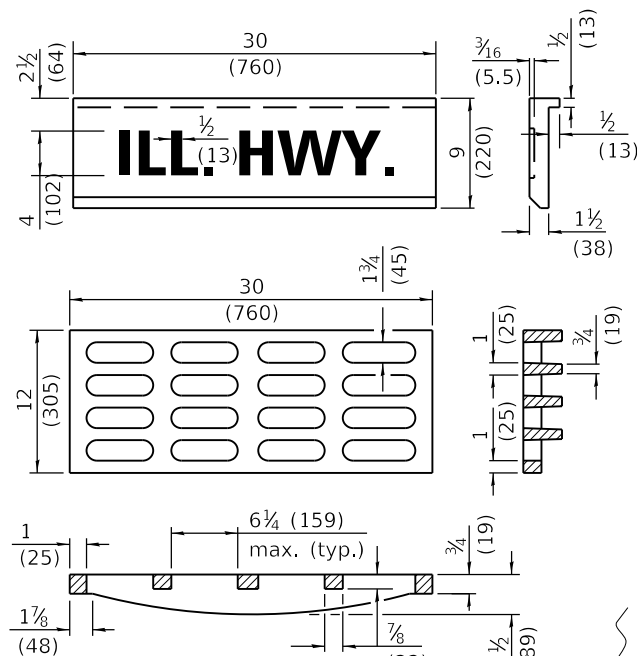

GRATE AND COVER TYPE 2B

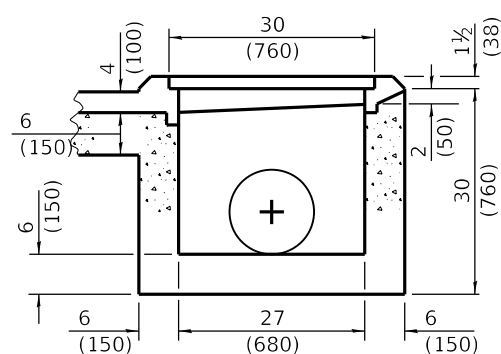

SECTION F-F

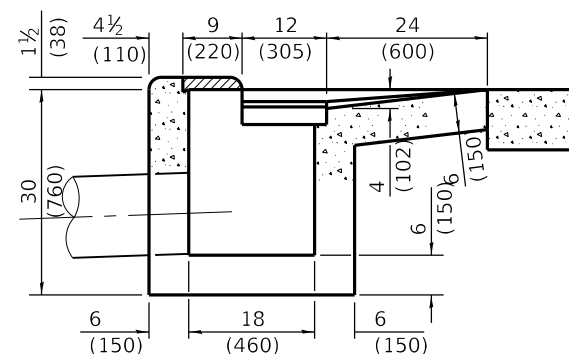

SECTION D-D

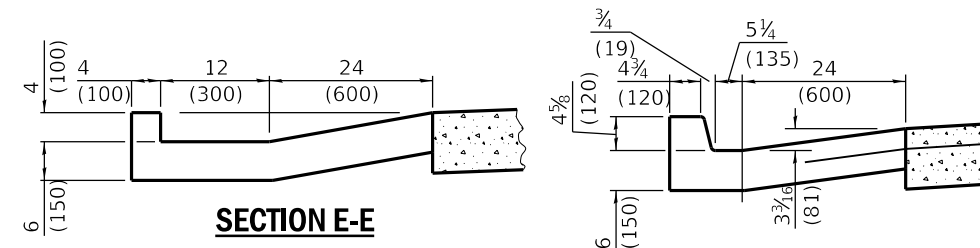

SECTION E-E

SECTION C-C

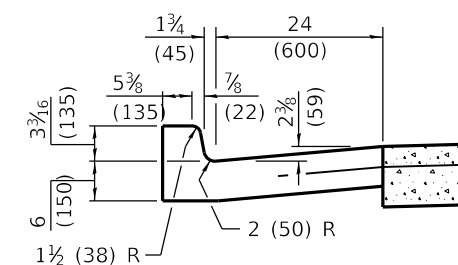

SECTION B-B

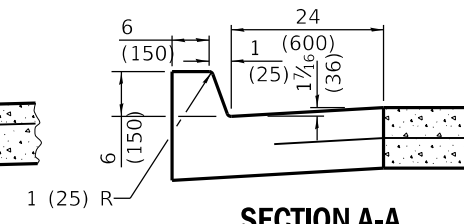

SECTION A-A

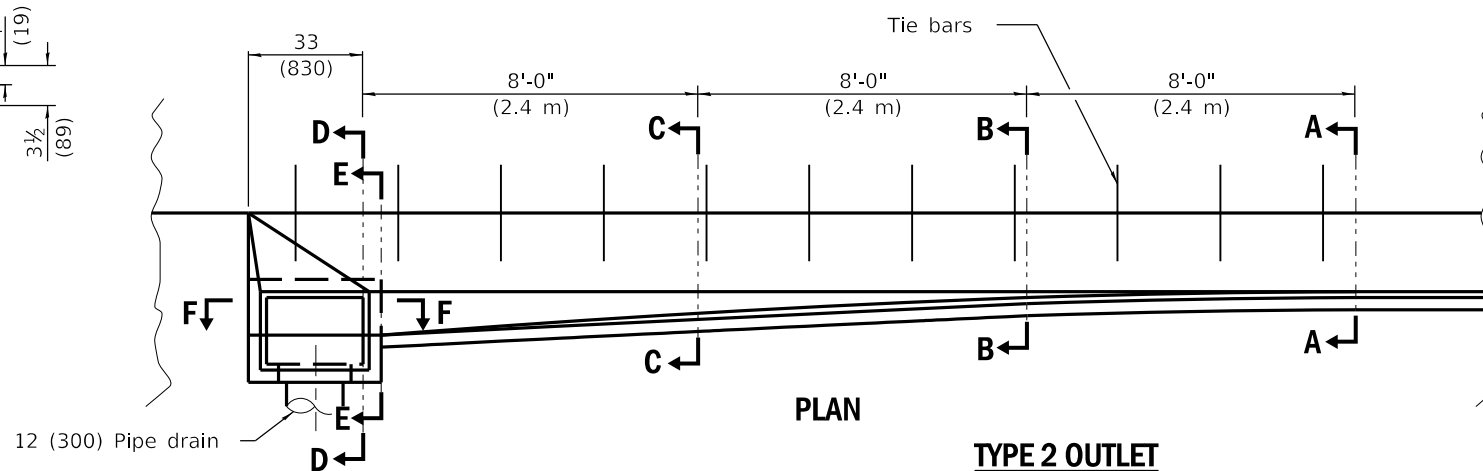

TYPE 2 OUTLET

QUANTITIES

2.07 cu. yds. (1.58 m³) concrete for 9 (225) pav't.

2.07 cu. yds. (1.60 m³) concrete for 10 (250) pav't.

All dimensions are in inches (millimeters) unless otherwise shown.

OUTLETS FOR CONCRETE CURB AND GUTTER TYPE B-6.24 (B-15.60)

(Sheet 2 of 2)

STANDARD 606006-04

Illinois Department of Transportation

PASSED January 1, 2018

Michael Brand
ENGINEER OF POLICY AND PROCEDURES

APPROVED January 1, 2018

Maureen M. Beck
ENGINEER OF DESIGN AND ENVIRONMENT

ISSUED 6-1-1-18

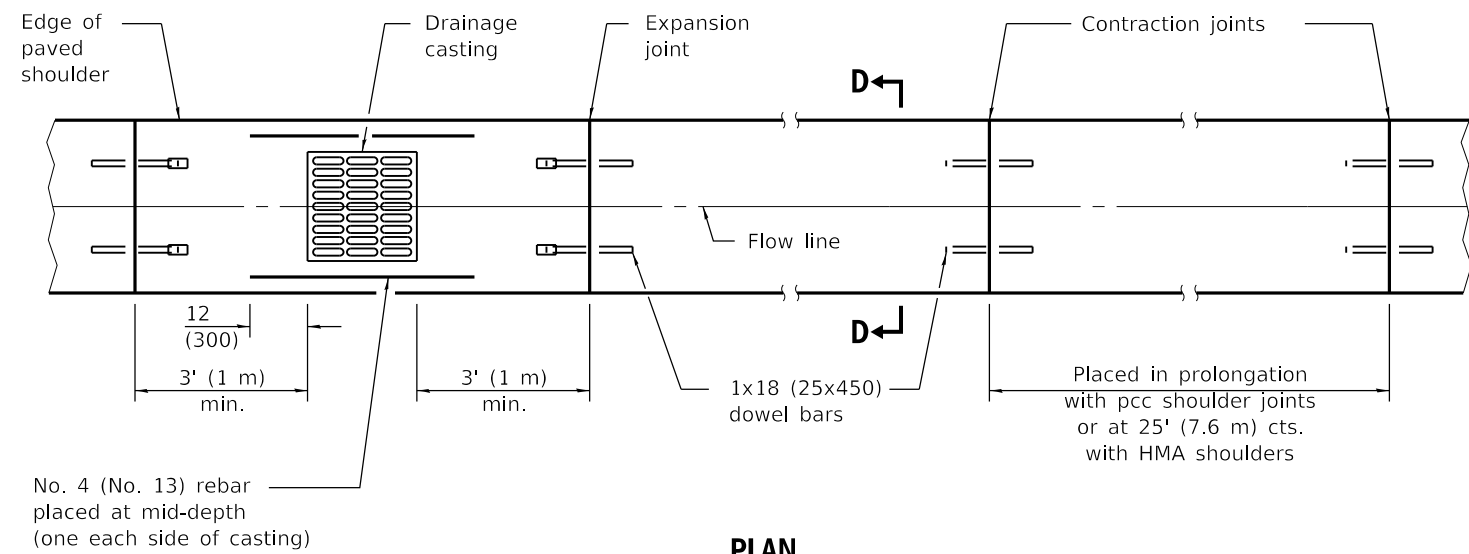

PLAN

TYPE A GUTTER

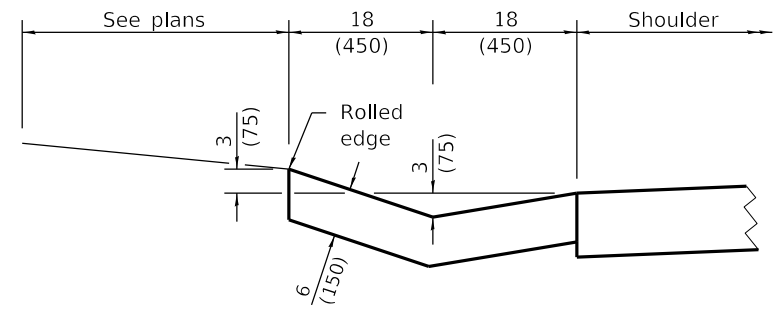

SECTION D-D

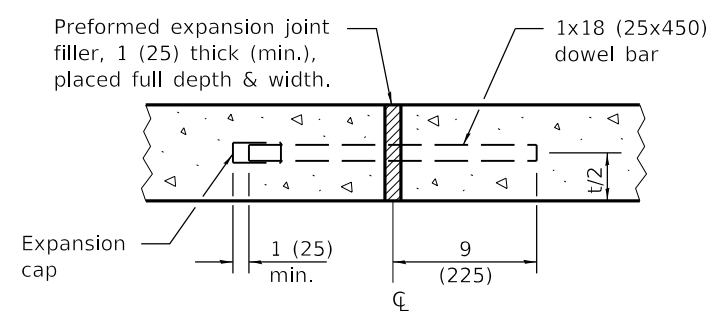

EXPANSION JOINT

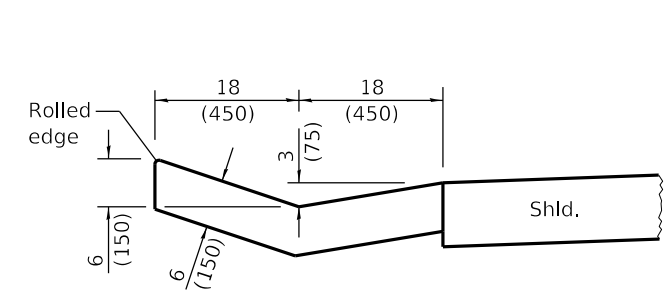

SECTION A-A

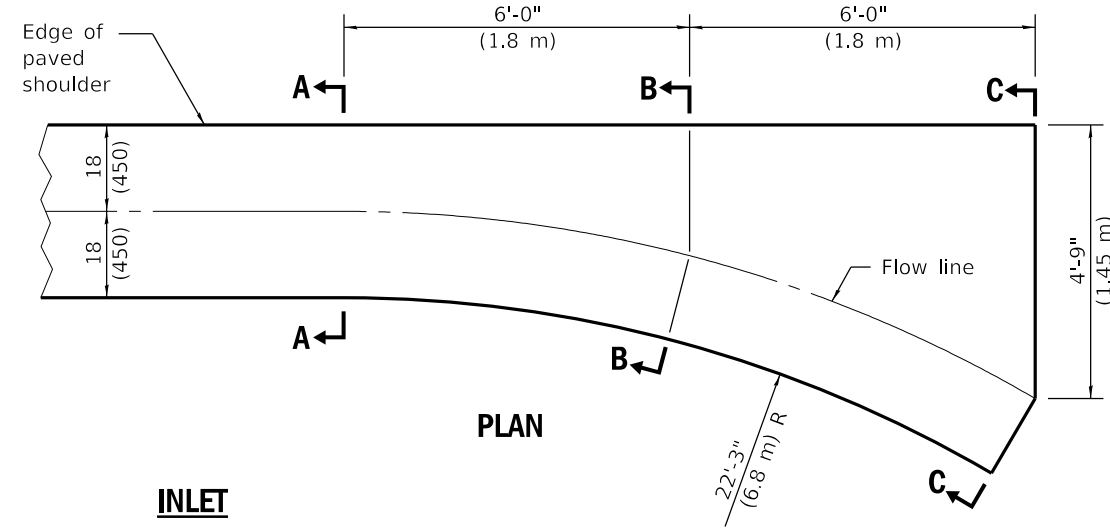

PLAN

INLET

QUANTITY OF CONCRETE
Section A-A to C-C
0.93 cu. yd. (0.71 m³)

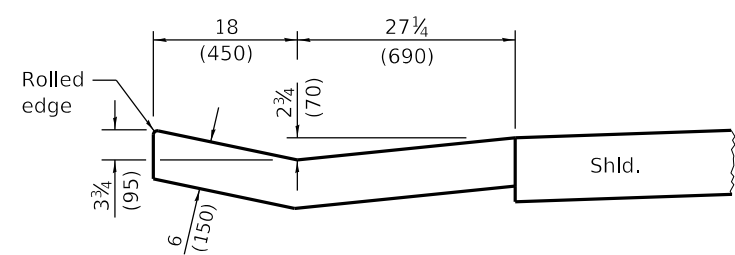

SECTION B-B

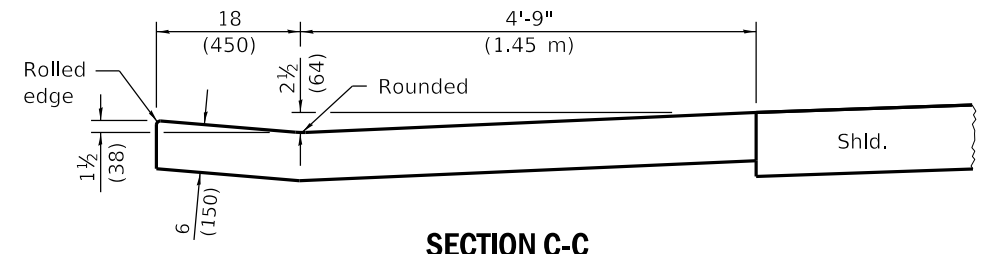

SECTION C-C

All dimensions are in inches (millimeters) unless otherwise shown.

Illinois Department of Transportation

PASSED April 1, 2016
Michael Beard
ENGINEER OF POLICY AND PROCEDURES

APPROVED April 1, 2016
[Signature]
ENGINEER OF DESIGN AND ENVIRONMENT

ISSUED 1-1-91
46-T 03N5S

DATE	REVISIONS
4-1-16	Changed terminology to 'welded wire reinforcement'.
1-1-09	Switched units to English (metric). Changed radii, adjusted qty's.

**TYPE A GUTTER
(INLET, OUTLET & ENTRANCE)**

(Sheet 1 of 3)

STANDARD 606101-05

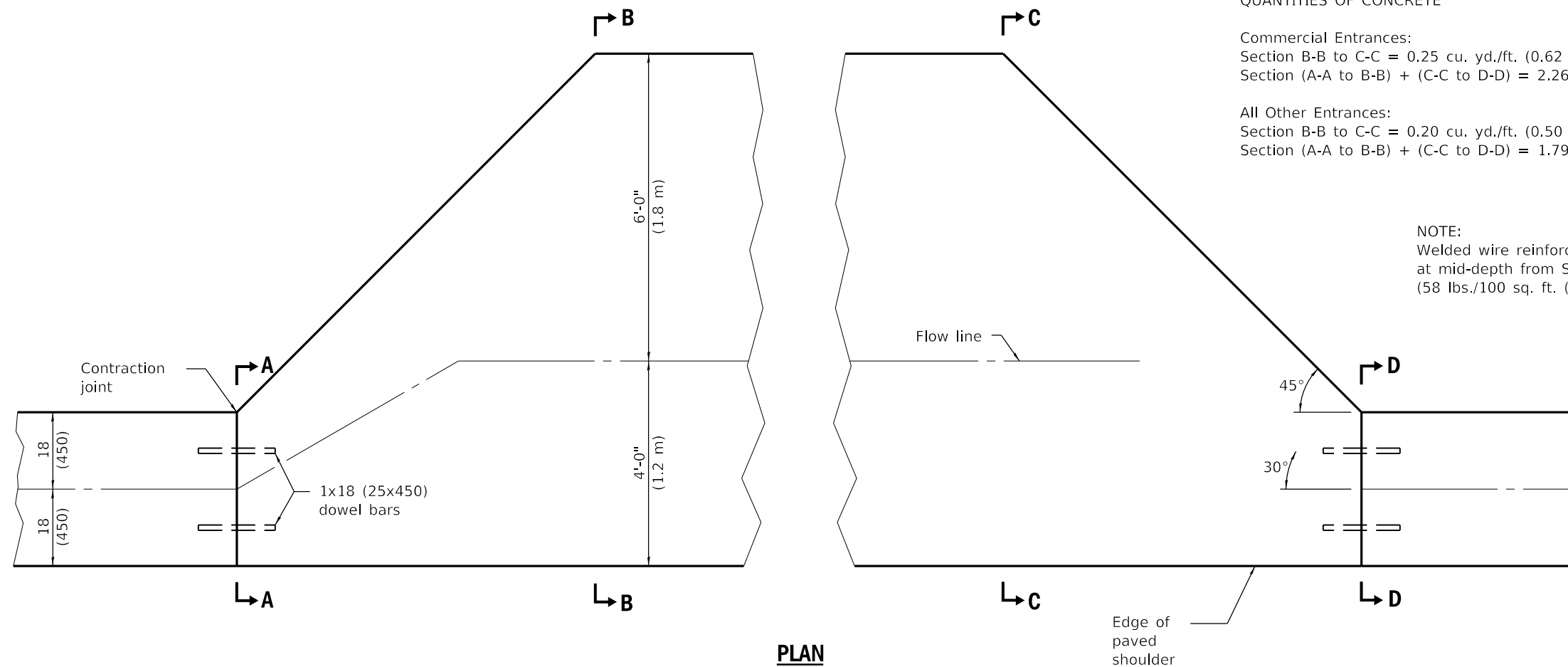

QUANTITIES OF CONCRETE

Commercial Entrances:
 Section B-B to C-C = 0.25 cu. yd./ft. (0.62 m³/m).
 Section (A-A to B-B) + (C-C to D-D) = 2.26 cu. yd. (1.73 m³).

All Other Entrances:
 Section B-B to C-C = 0.20 cu. yd./ft. (0.50 m³/m).
 Section (A-A to B-B) + (C-C to D-D) = 1.79 cu. yd. (1.37 m³).

NOTE:
 Welded wire reinforcement shall be installed
 at mid-depth from Section A-A to D-D.
 (58 lbs./100 sq. ft. (2.83 kg/m²))

PLAN

ENTRANCE

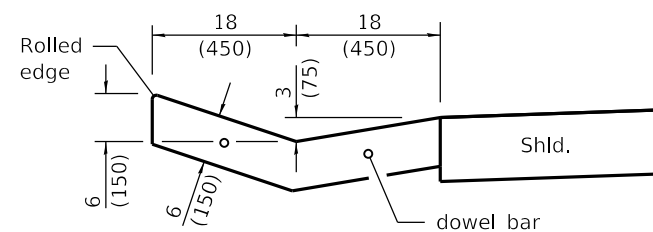

SECTIONS A-A & D-D

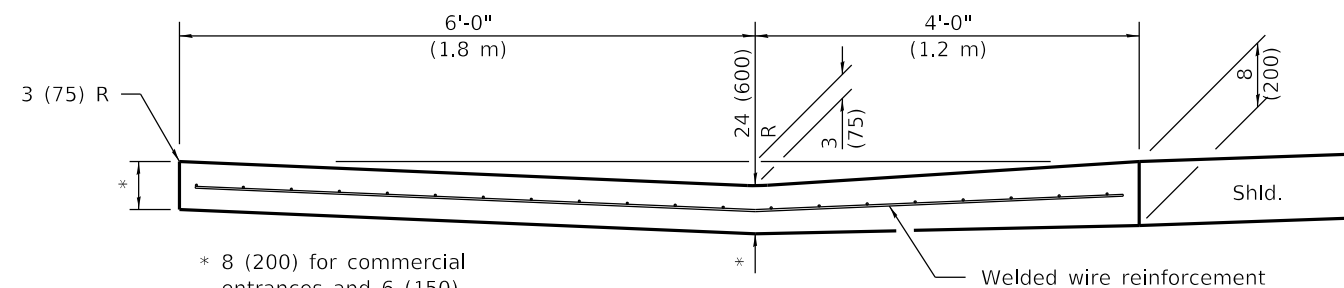

* 8 (200) for commercial
 entrances and 6 (150)
 for all others.

SECTIONS B-B & C-C

Illinois Department of Transportation

PASSED April 1, 2016
Michael Beard
 ENGINEER OF POLICY AND PROCEDURES

APPROVED April 1, 2016
[Signature]
 ENGINEER OF DESIGN AND ENVIRONMENT

ISSUED 1-1-97

**TYPE A GUTTER
 (INLET, OUTLET & ENTRANCE)**

(Sheet 2 of 3)

STANDARD 606101-05

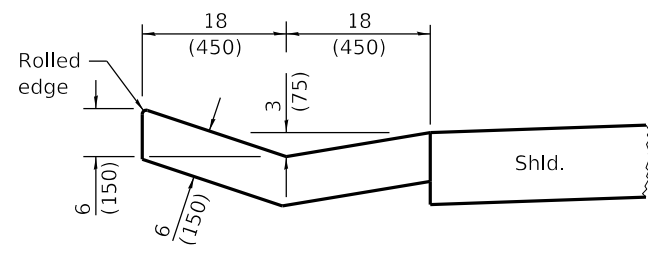

SECTION A-A

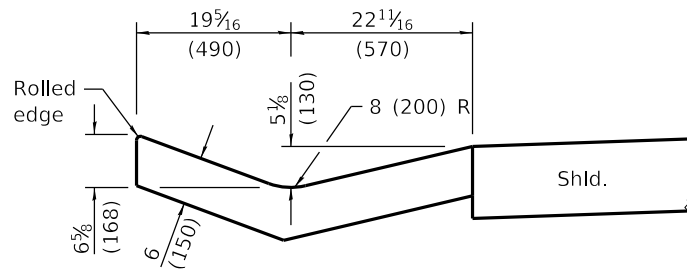

SECTION B-B

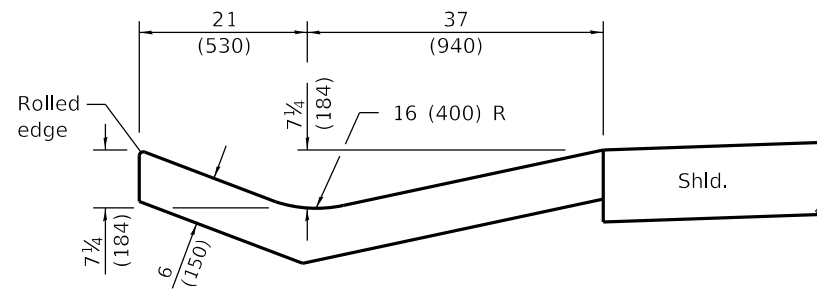

SECTION C-C

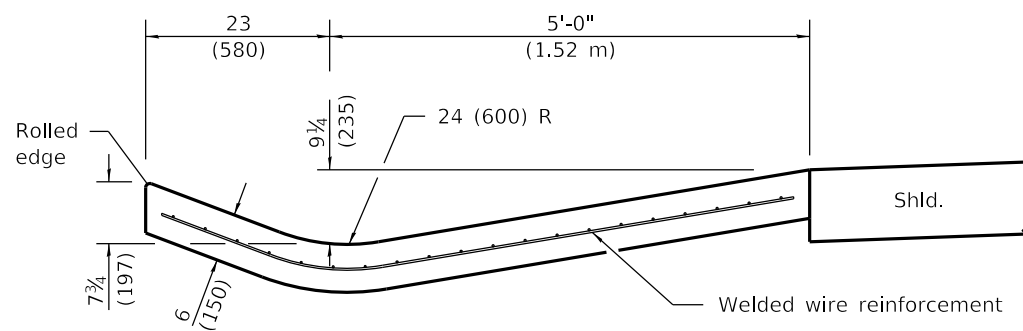

SECTION D-D

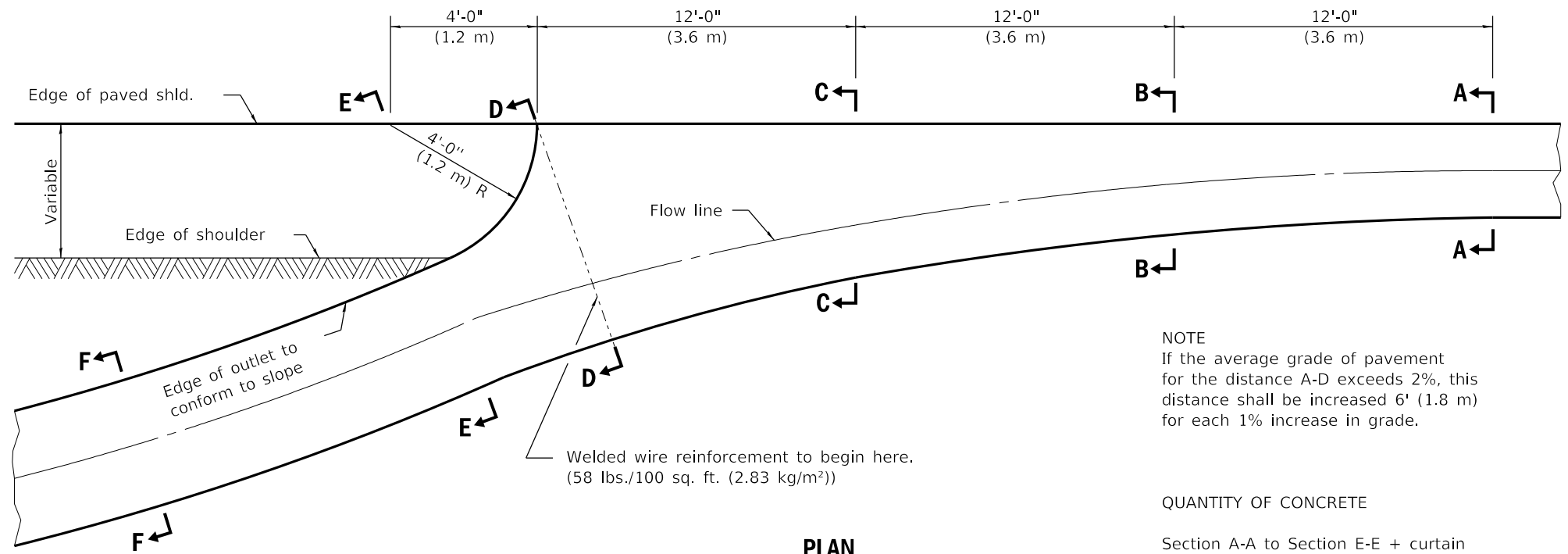

OUTLET

PLAN

NOTE
If the average grade of pavement for the distance A-D exceeds 2%, this distance shall be increased 6' (1.8 m) for each 1% increase in grade.

QUANTITY OF CONCRETE

Section A-A to Section E-E + curtain wall = 3.53 cu. yd. (2.70 m³) of concrete.
Section F-F = 0.079 cu. yd./ft. (0.2 m³/m).

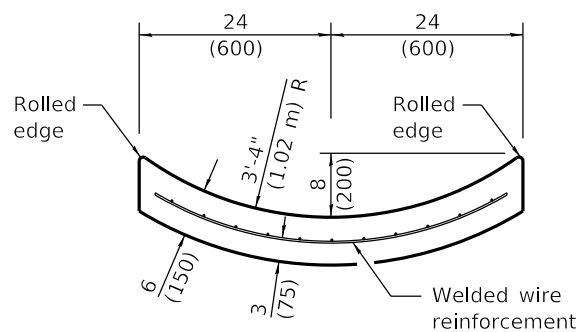

SECTION F-F

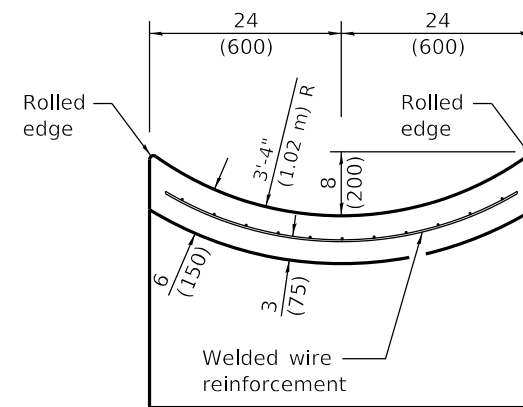

SECTIONS AT END OF OUTLET

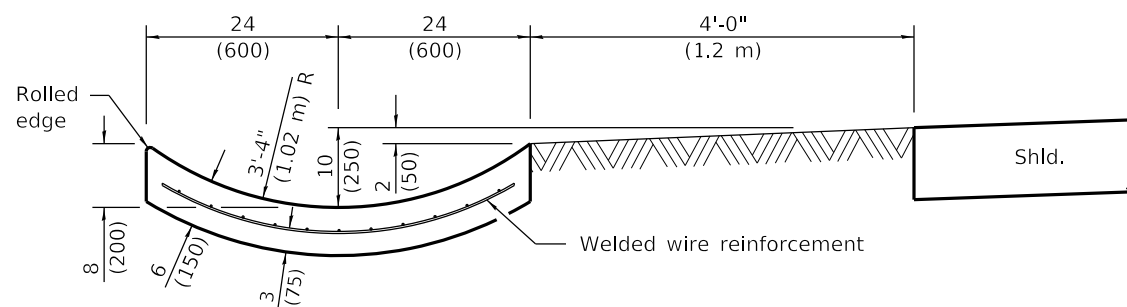
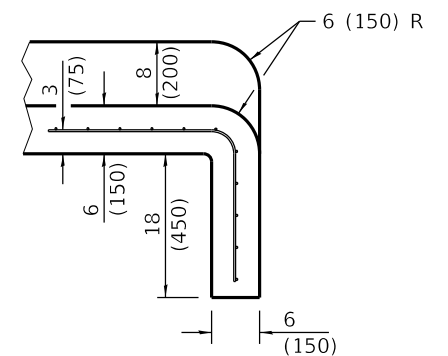

SECTION E-E

Illinois Department of Transportation

PASSED Michael Beard April 1, 2016
ENGINEER OF POLICY AND PROCEDURES

APPROVED [Signature] April 1, 2016
ENGINEER OF DESIGN AND ENVIRONMENT

ISSUED 1-1-97

**TYPE A GUTTER
(INLET, OUTLET & ENTRANCE)**

(Sheet 3 of 3)

STANDARD 606101-05

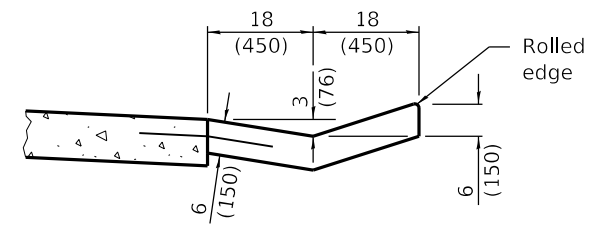

SECTION A-A

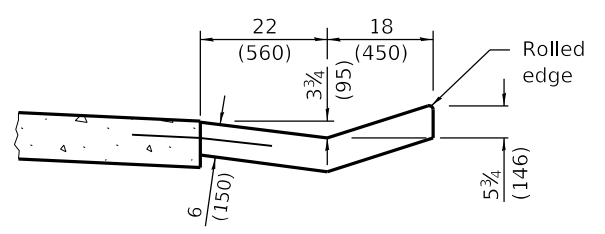

SECTION B-B

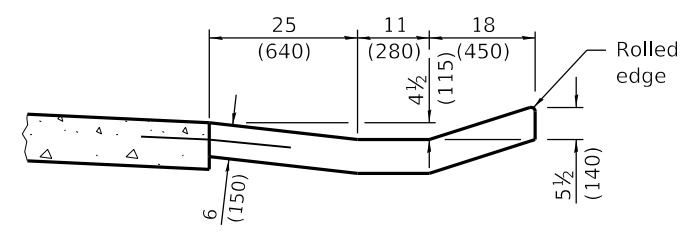

SECTION C-C

QUANTITIES

Material	Single	Double
Concrete - cu. yd. (m ³)	3.3 (2.5)	6.5 (5)
Cast Iron Grate - Ea.	1	2
Pipe Drain - Dia. in. (mm)	15 (375)	18 (450)

GENERAL NOTES

The gutter outlet shall be tied to the pavement in accordance with details for longitudinal construction joint shown on Standard 420001.

Tie bars shall be No. 6 (No. 19) at 36 (900) centers unless otherwise shown.

If the average grade of pavement for the distance A-D exceeds 2%, this distance shall be increased 6' (1.8 m) for each 1% increase in grade.

All dimensions are in inches (millimeters) unless otherwise shown.

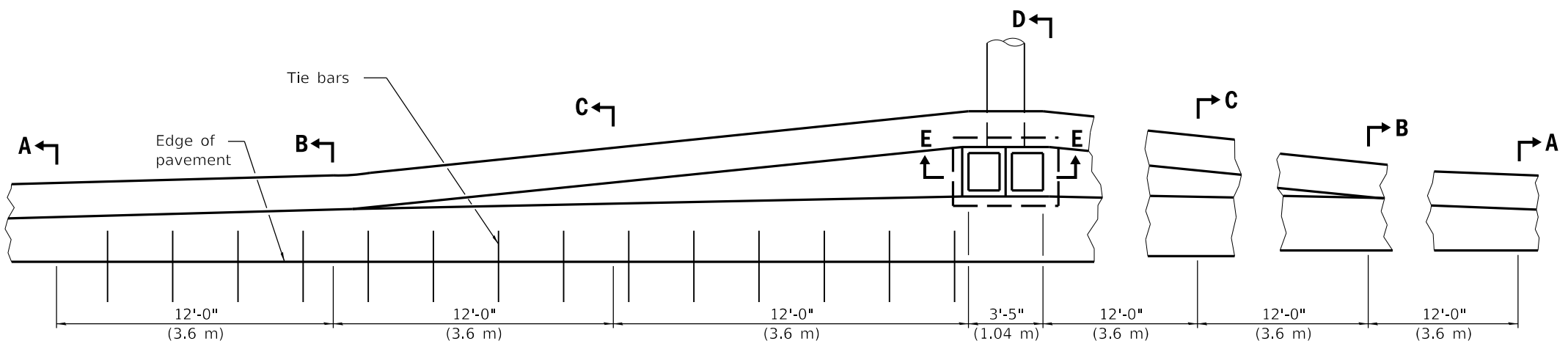

PLAN-DOUBLE OUTLET

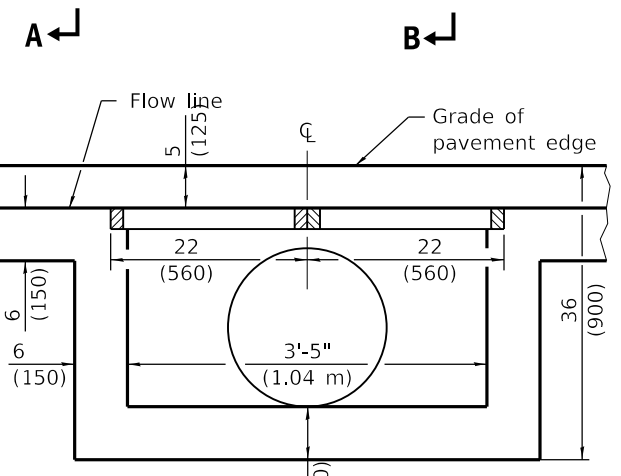

SECTION E-E

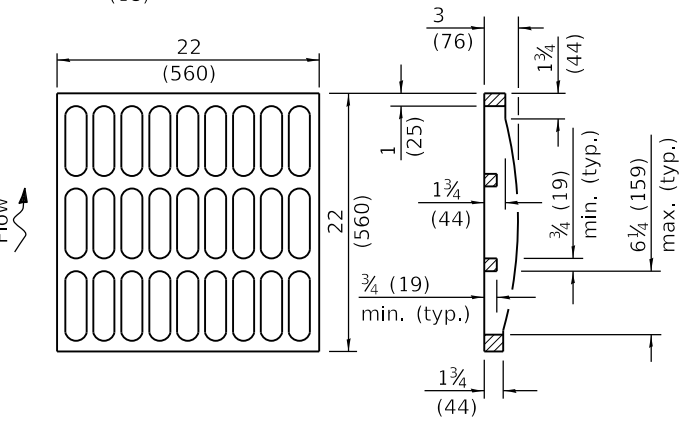
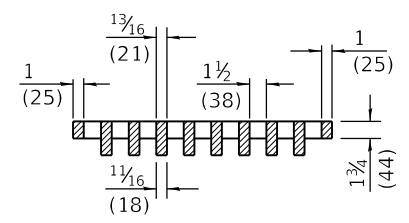

GRATE TYPE A

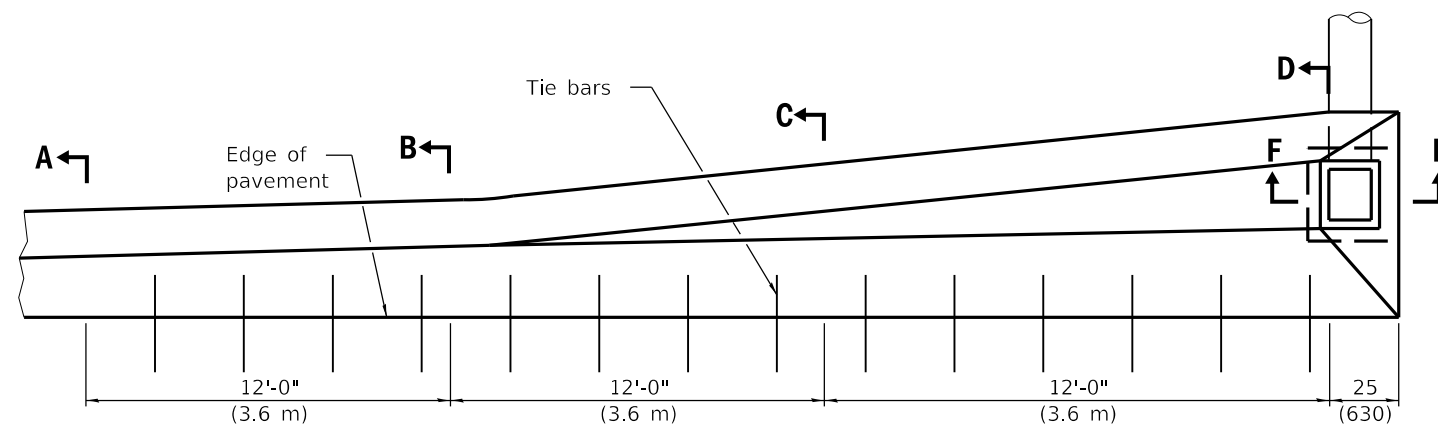

PLAN-SINGLE OUTLET

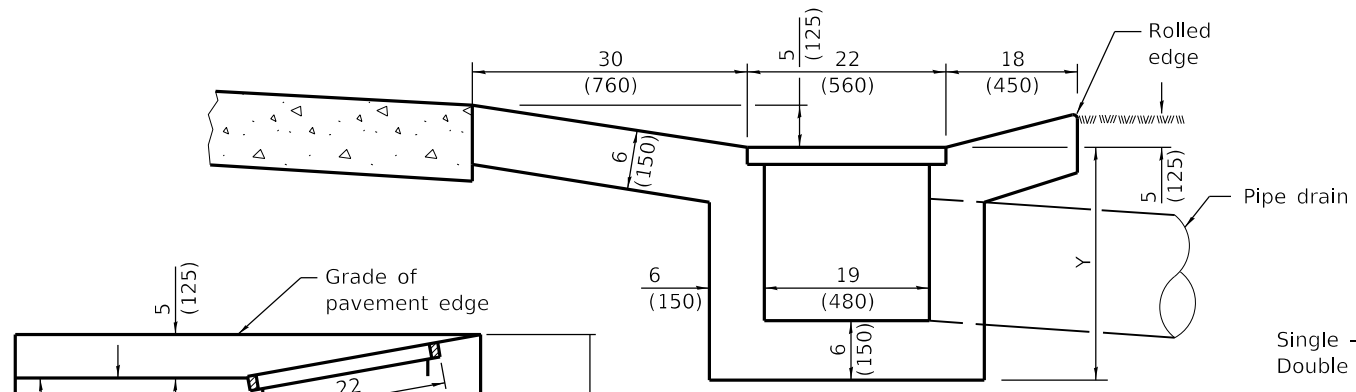

SECTION D-D

Single - Y = 25 (635)
Double - Y = 31 (775)

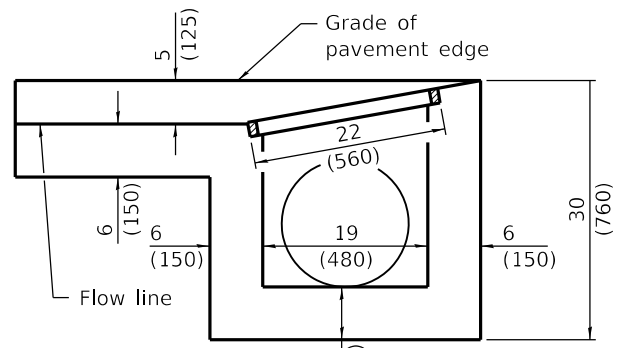

SECTION F-F

DATE	REVISIONS
1-1-18	Revised General Notes for tie bar spacing of 36 (900) cts.
1-1-09	Switched units to English (metric).

OUTLET TYPE 1 FOR TYPE A GUTTER

STANDARD 606106-05

Illinois Department of Transportation

PASSED January 1, 2018
Michael Beard
ENGINEER OF POLICY AND PROCEDURES

APPROVED January 1, 2018
Maurice M. Beck
ENGINEER OF DESIGN AND ENVIRONMENT

ISSUED 46-1-1-18

NOTE
 If the average grade of pavement for the distance A-E exceeds 2%, this distance shall be increased 6 ft. (1.8 m) for each 1% increase in grade.

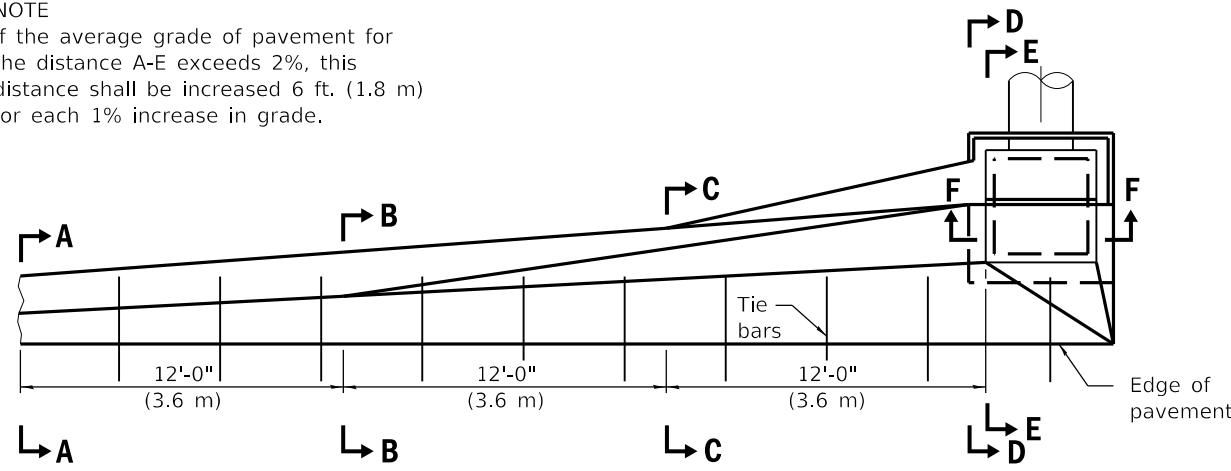

PLAN - SINGLE OUTLET

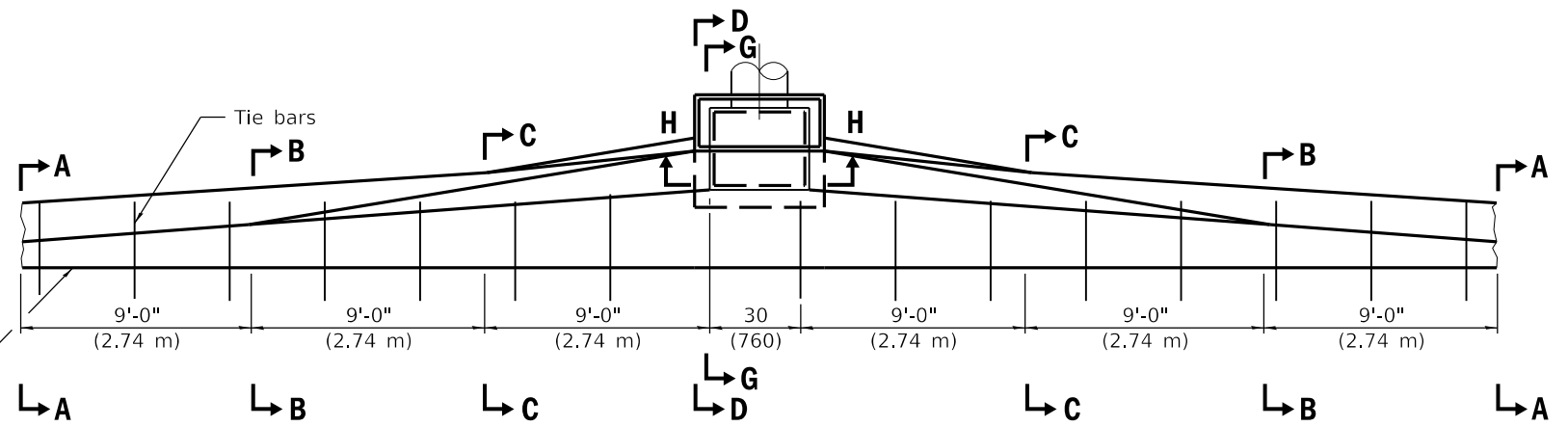

PLAN - DOUBLE OUTLET

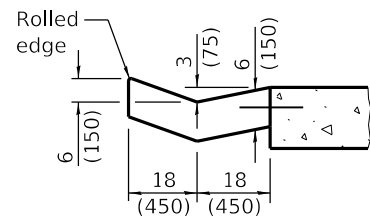

SECTION A-A

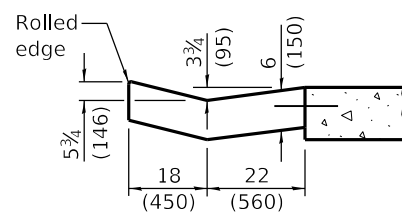

SECTION B-B

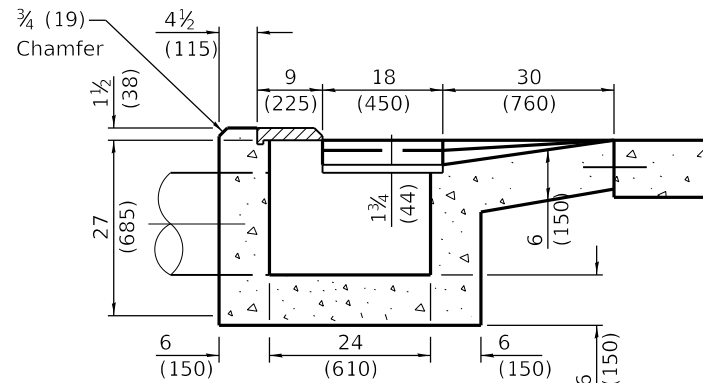

SECTION E-E

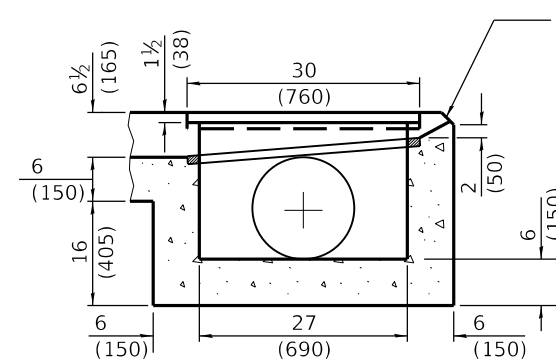

SECTION F-F

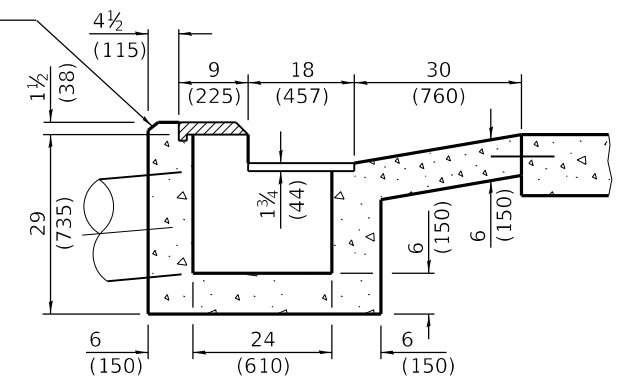

SECTION G-G

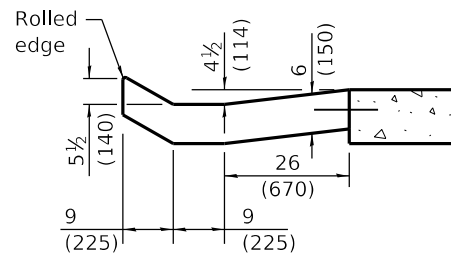

SECTION C-C

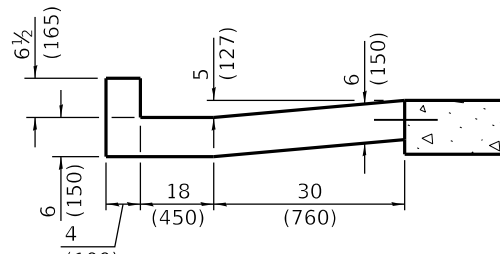

SECTION D-D

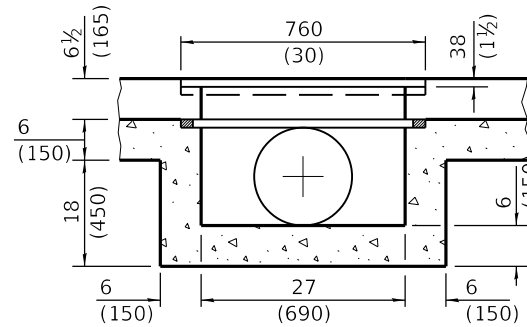

SECTION H-H

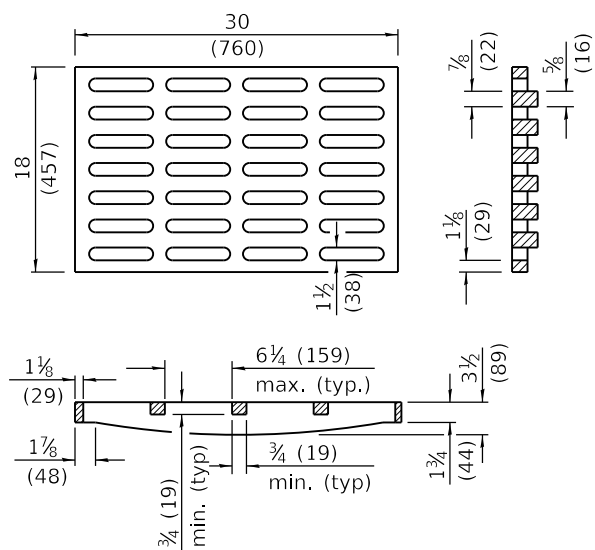

GRATE AND COVER TYPE 2A

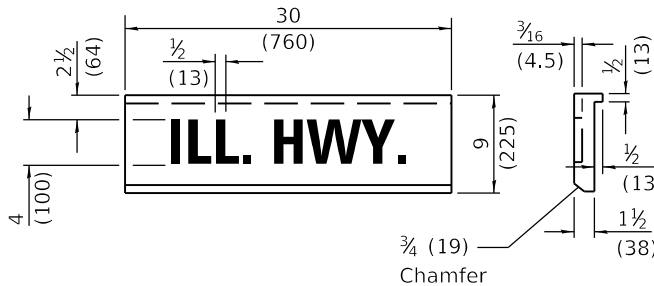

QUANTITIES

Material	Single	Double
Concrete - cu. yd. (m ³)	3.07 (2.35)	4.33 (3.31)
Cast Iron Grate - Ea.	1	1
Cast Iron Cover - Ea.	1	1
Pipe Drain - Dia. in. (mm)	15 (375)	18 (450)

GENERAL NOTES

The gutter outlet shall be tied to the pavement in accordance with details for longitudinal construction joint shown on Standard 420001.

All dimensions are in inches (millimeters) unless otherwise shown.

DATE	REVISIONS
1-1-09	Switched units to English (metric).
1-1-07	Removed weight of grate and cover.

OUTLETS TYPE 2 FOR TYPE A GUTTER

STANDARD 606111-03

Illinois Department of Transportation

PASSED January 1, 2009

ENGINEER OF POLICY AND PROCEDURES

APPROVED January 1, 2009

ENGINEER OF DESIGN AND ENVIRONMENT

ISSUED 1-1-09

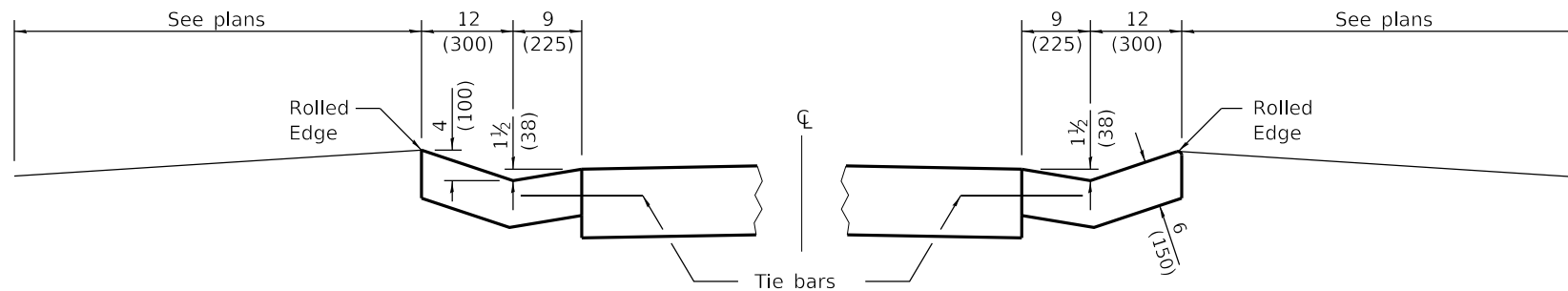

TYPE B GUTTER

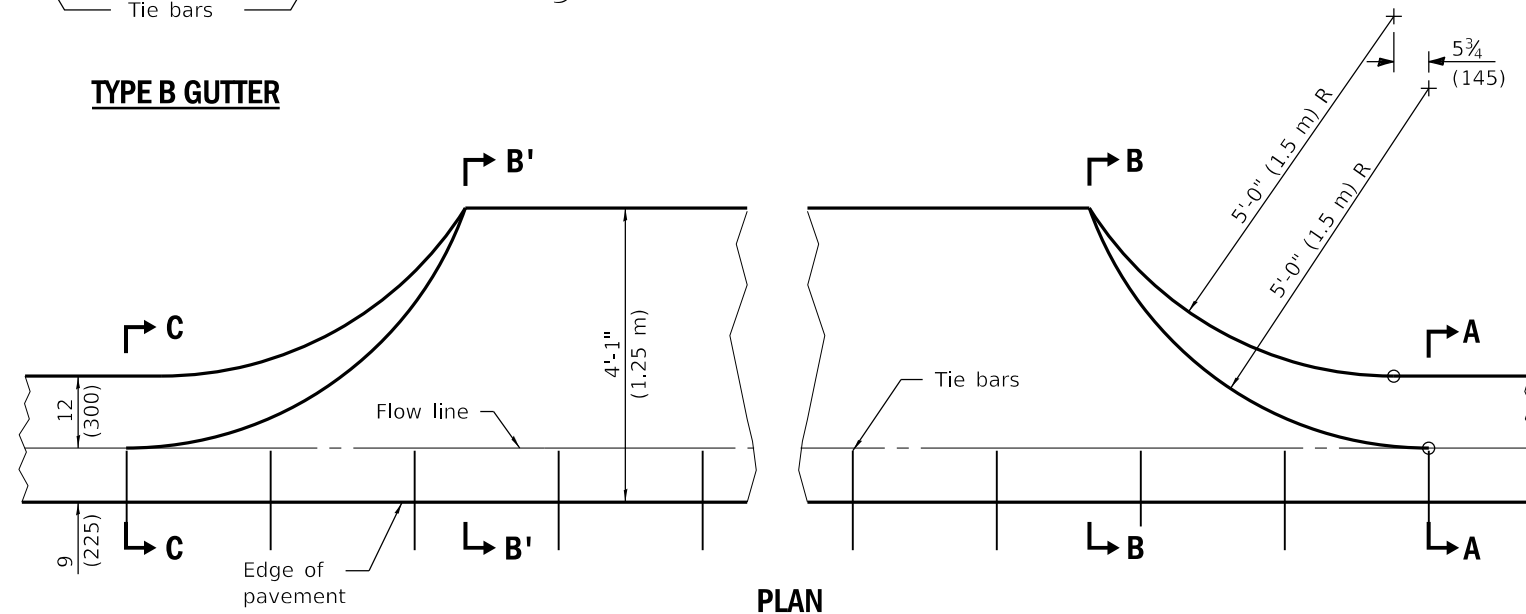

PLAN

QUANTITY OF CONCRETE
 Section B'-B' to B-B = 0.076 cu. yd./ft. (0.19 m³/m)
 Section (C-C to B'-B') + (B-B to A-A) = 0.44 cu. yd. (0.34 m³)

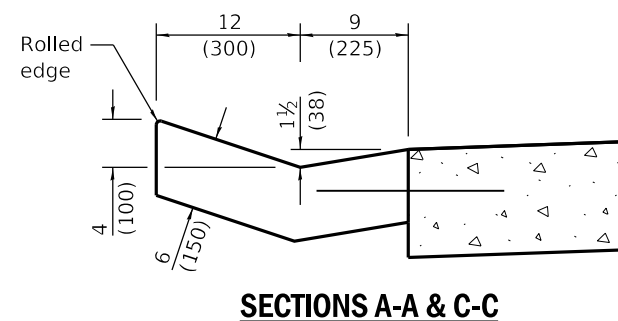

SECTIONS A-A & C-C

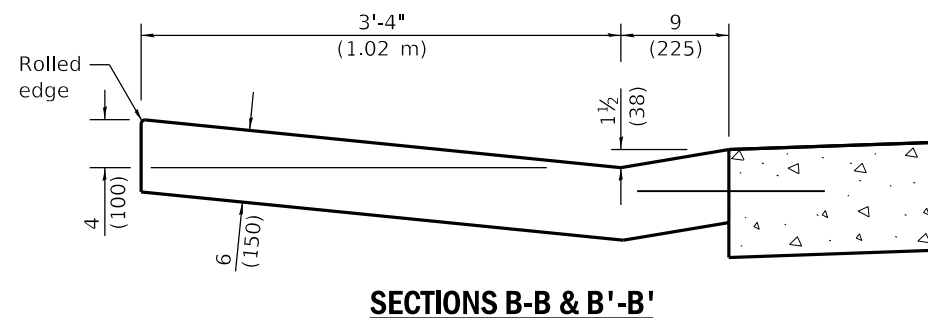

SECTIONS B-B & B'-B'

ENTRANCE

GENERAL NOTES

Gutter, gutter inlet, gutter outlet and gutter entrance shall be tied to the pavement in accordance with details for longitudinal construction joint shown on Standard 420001.

Two 1-1/4 x 18 (32 x 450) dowel bars shall be installed in all joints when the gutter is constructed adjacent to flexible pavement.

All dimensions are in inches (millimeters) unless otherwise shown.

**TYPE B GUTTER
 (INLET, OUTLET & ENTRANCE)**

(Sheet 1 of 2)

STANDARD 606201-04

DATE	REVISIONS
1-1-18	Deleted first General Note to avoid conflict with second General Note.
4-1-16	Changed terminology to 'welded wire reinforcement'.

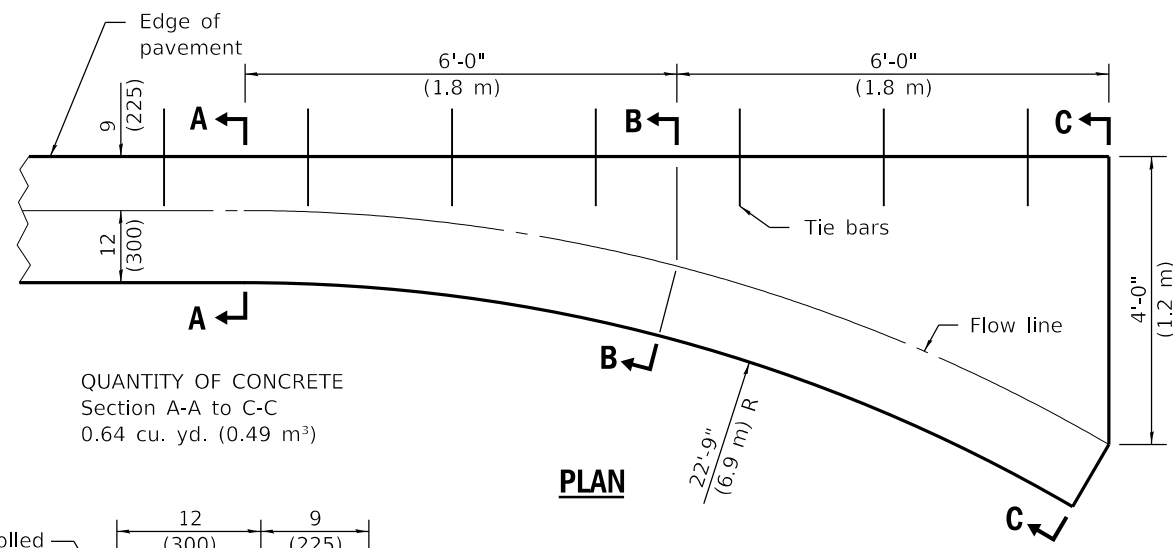

PLAN

QUANTITY OF CONCRETE
 Section A-A to C-C
 0.64 cu. yd. (0.49 m³)

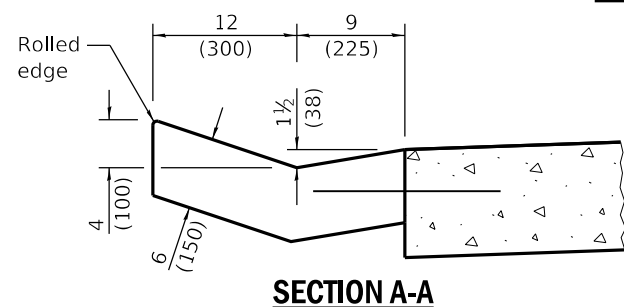

SECTION A-A

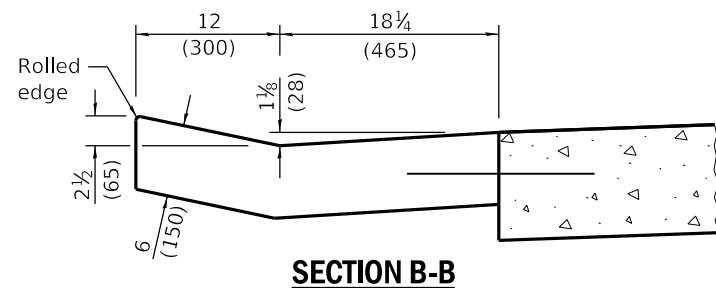

SECTION B-B

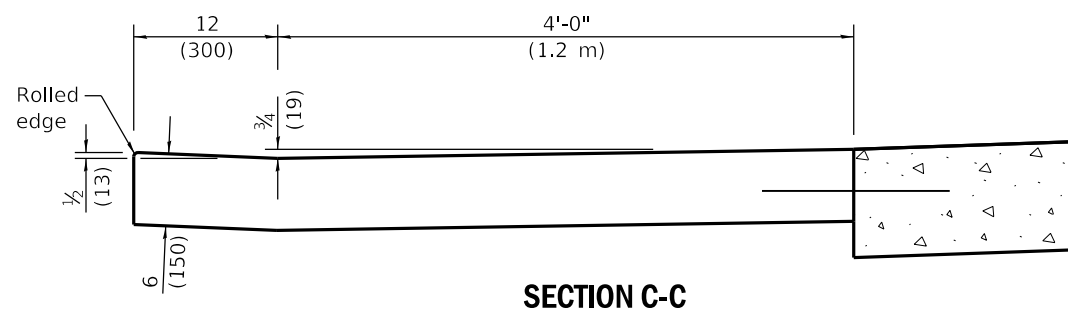

SECTION C-C

INLET

Illinois Department of Transportation

PASSED January 1, 2018
Michael Beard
 ENGINEER OF POLICY AND PROCEDURES

APPROVED January 1, 2018
Maureen M. Beck
 ENGINEER OF DESIGN AND ENVIRONMENT

ISSUED 1-1-97

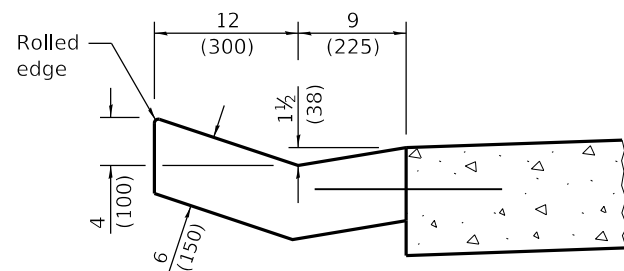

SECTION A-A

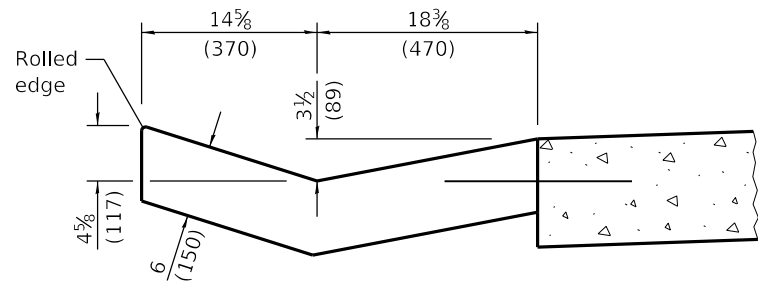

SECTION B-B

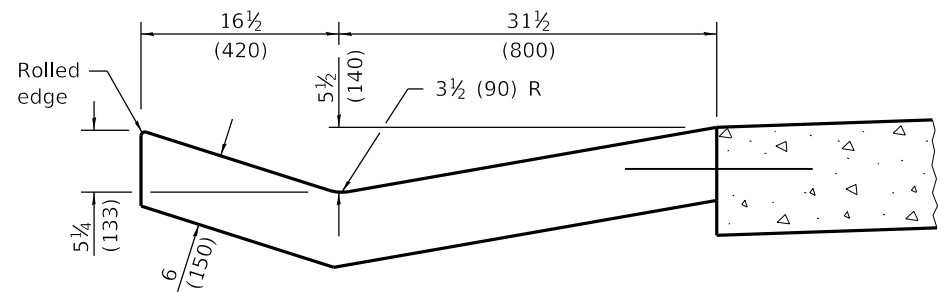

SECTION C-C

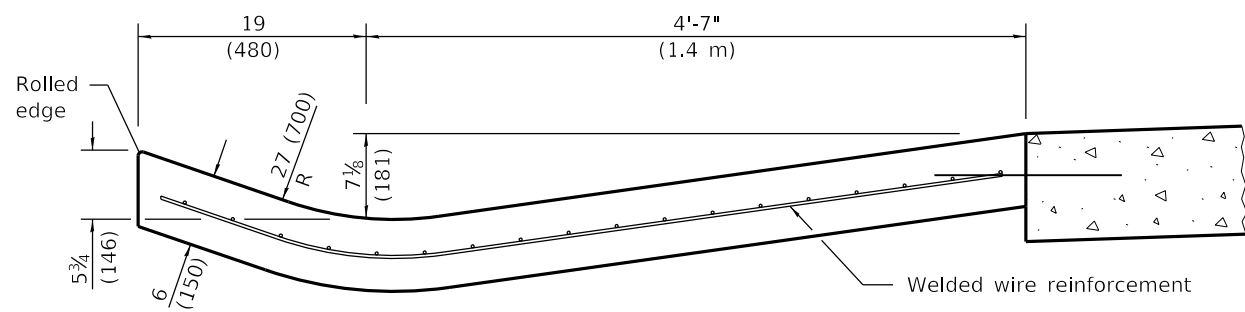

SECTION D-D

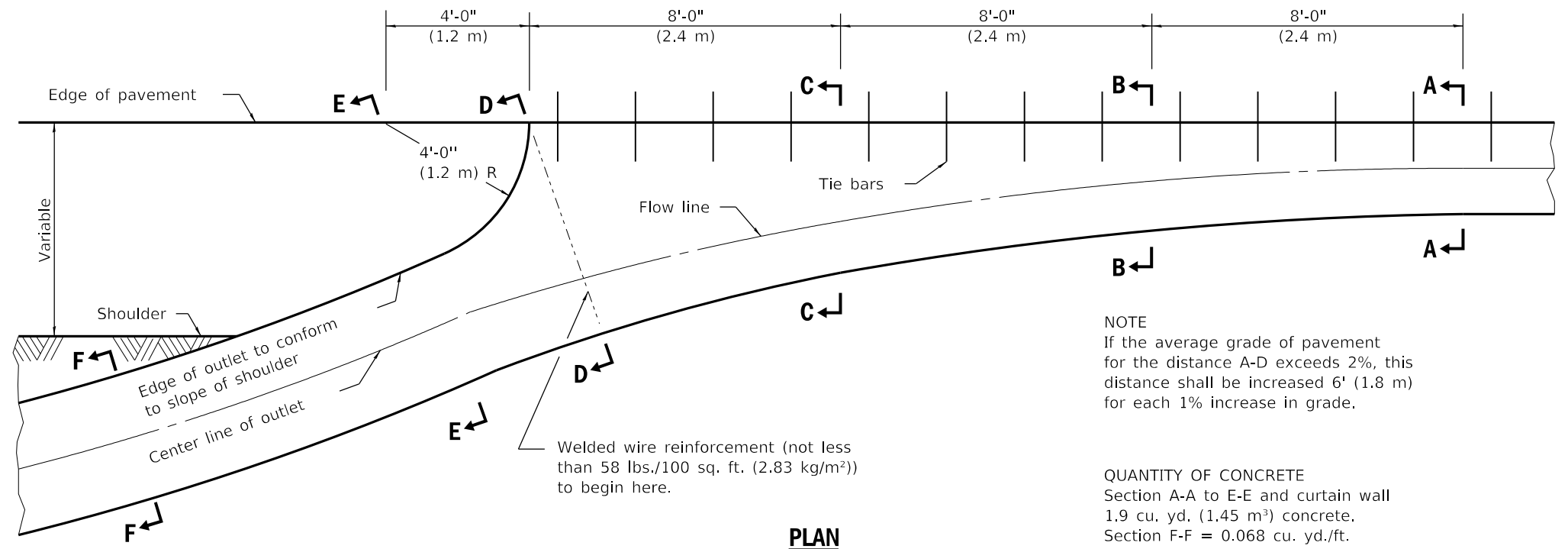

PLAN

NOTE
If the average grade of pavement for the distance A-D exceeds 2%, this distance shall be increased 6' (1.8 m) for each 1% increase in grade.

QUANTITY OF CONCRETE
Section A-A to E-E and curtain wall 1.9 cu. yd. (1.45 m³) concrete.
Section F-F = 0.068 cu. yd./ft. (0.17 m³/m).

OUTLET

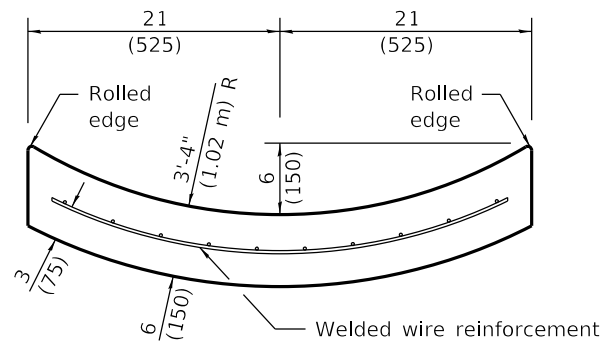

SECTION F-F

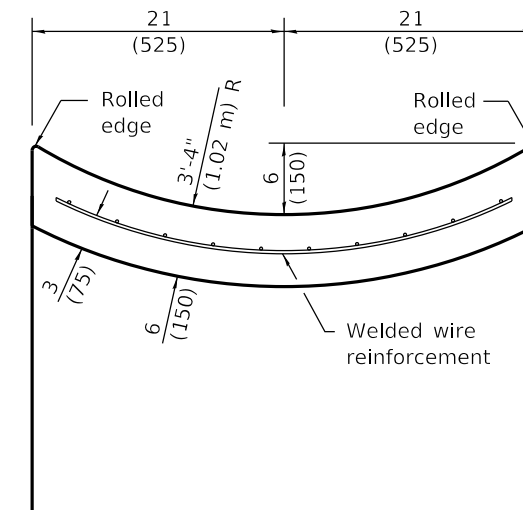

SECTIONS AT END OF OUTLET

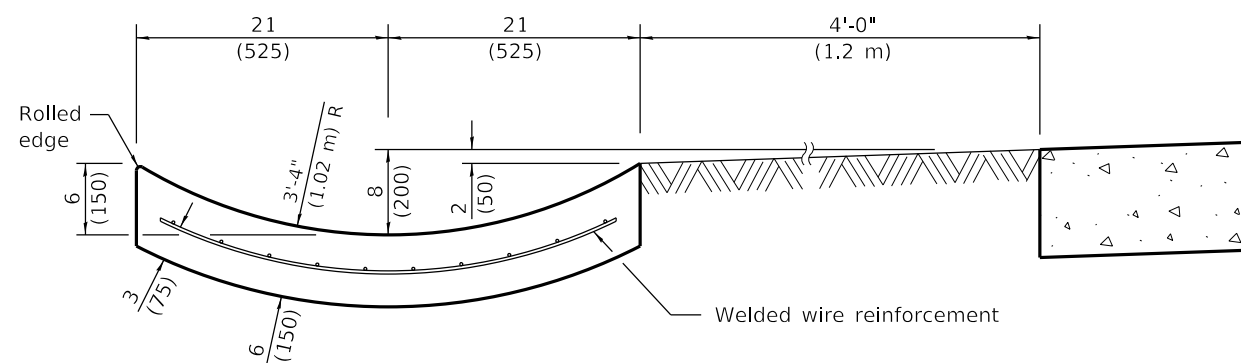
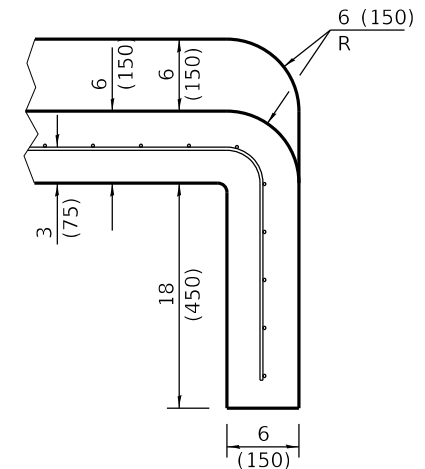

SECTION E-E

Illinois Department of Transportation
PASSED January 1, 2018
Michael Beard
ENGINEER OF POLICY AND PROCEDURES
APPROVED January 1, 2018
Maureen M. Beck
ENGINEER OF DESIGN AND ENVIRONMENT
ISSUED 1-1-97

**TYPE B GUTTER
(INLET, OUTLET & ENTRANCE)**

(Sheet 2 of 2)

STANDARD 606201-04

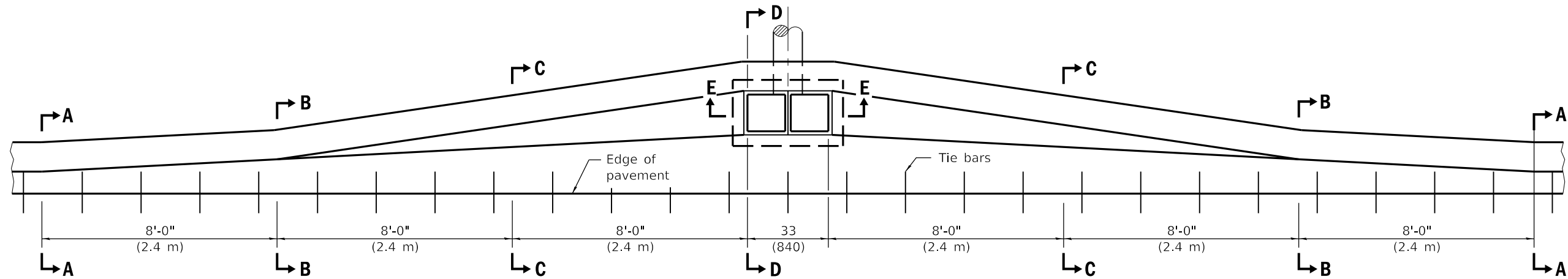

PLAN - DOUBLE OUTLET

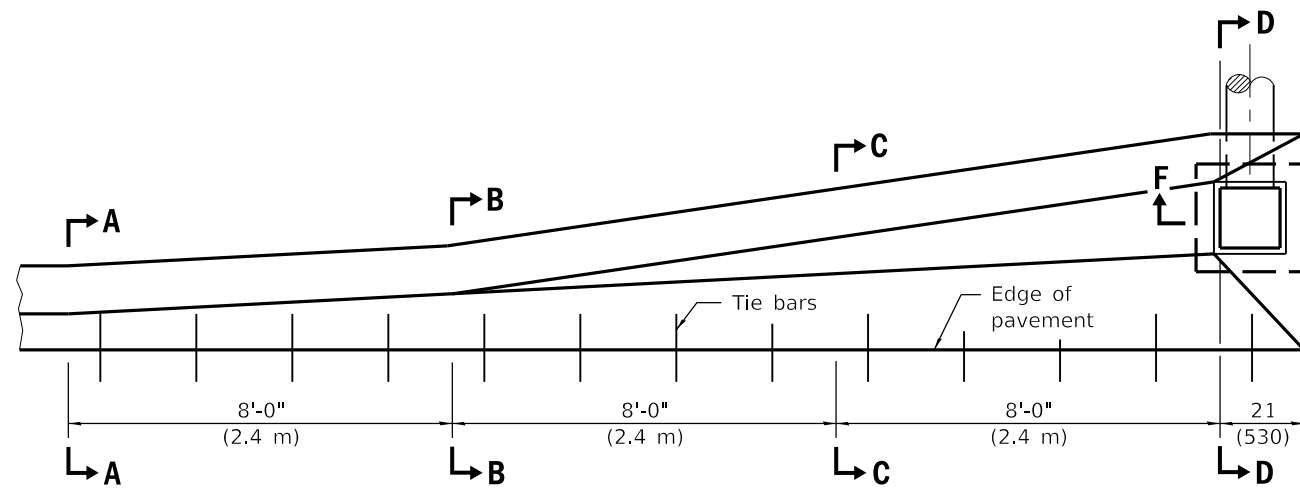

PLAN - SINGLE OUTLET

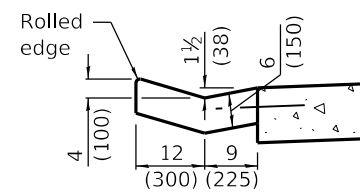

SECTION A-A

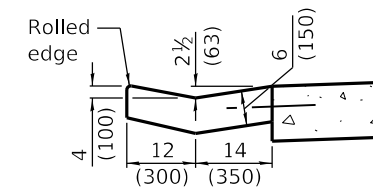

SECTION B-B

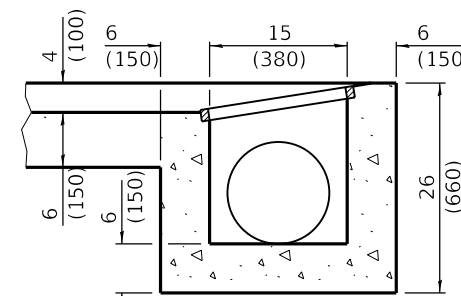

SECTION F-F

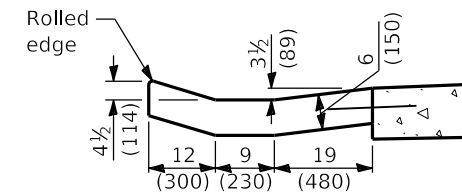

SECTION C-C

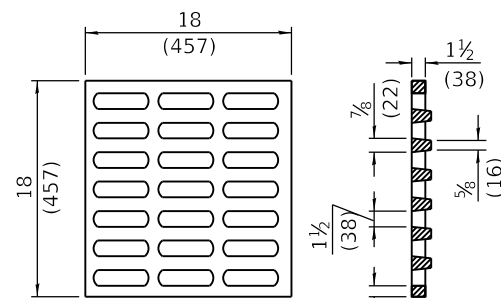

GRATE TYPE B

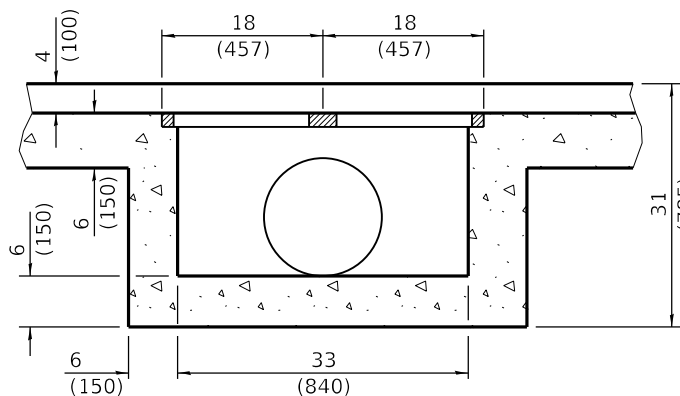

SECTION E-E

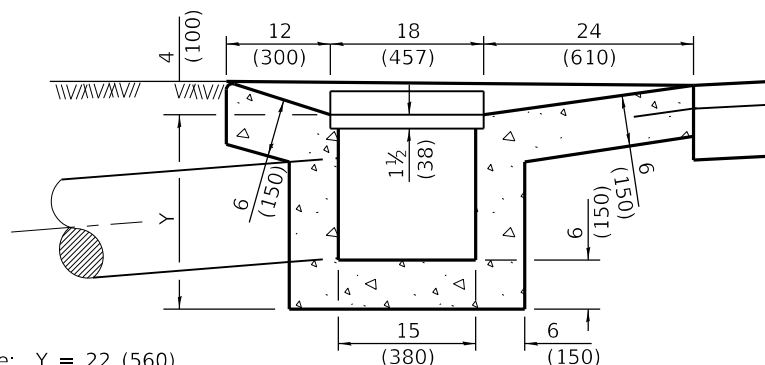

SECTION D-D

Single: Y = 22 (560)
Double: Y = 27 (685)

QUANTITIES

Material	Single	Double
Concrete - cu. yd. (m ³)	1.7 (1.3)	3.1 (2.4)
Cast Iron Grate - Ea.	1	2
Pipe Drain - Dia. in (mm)	12 (300)	15 (375)

GENERAL NOTES

The gutter outlet shall be tied to the pavement in accordance with details for longitudinal construction joint shown on Standard 420001.

If the average grade of the pavement for the distance A-D exceeds 2%, this distance shall be increased 6'-0" (1.8 m) for each 1% increase in grade.

All dimensions are in inches (millimeters) unless otherwise shown.

DATE	REVISIONS
1-1-18	Deleted second General Note to avoid conflict with first General Note.
1-1-09	Switched units to English (metric).

**OUTLET TYPE 1 FOR
TYPE B GUTTER**

STANDARD 606206-04

Illinois Department of Transportation

PASSED January 1, 2018
Michael Beard
ENGINEER OF POLICY AND PROCEDURES

APPROVED January 1, 2018
Maureen M. Beck
ENGINEER OF DESIGN AND ENVIRONMENT

ISSUED 6-1-18

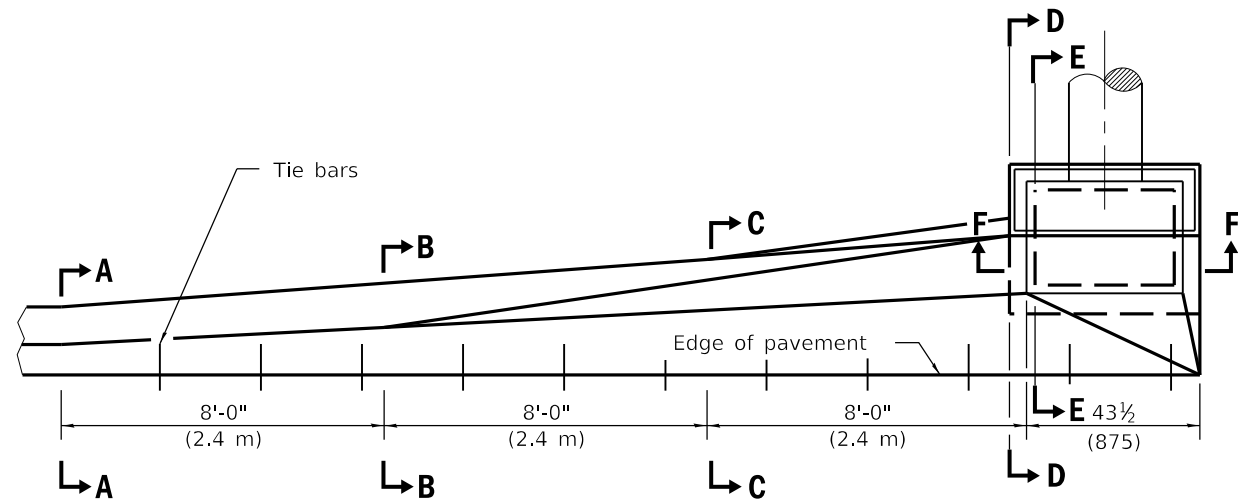

PLAN - SINGLE OUTLET

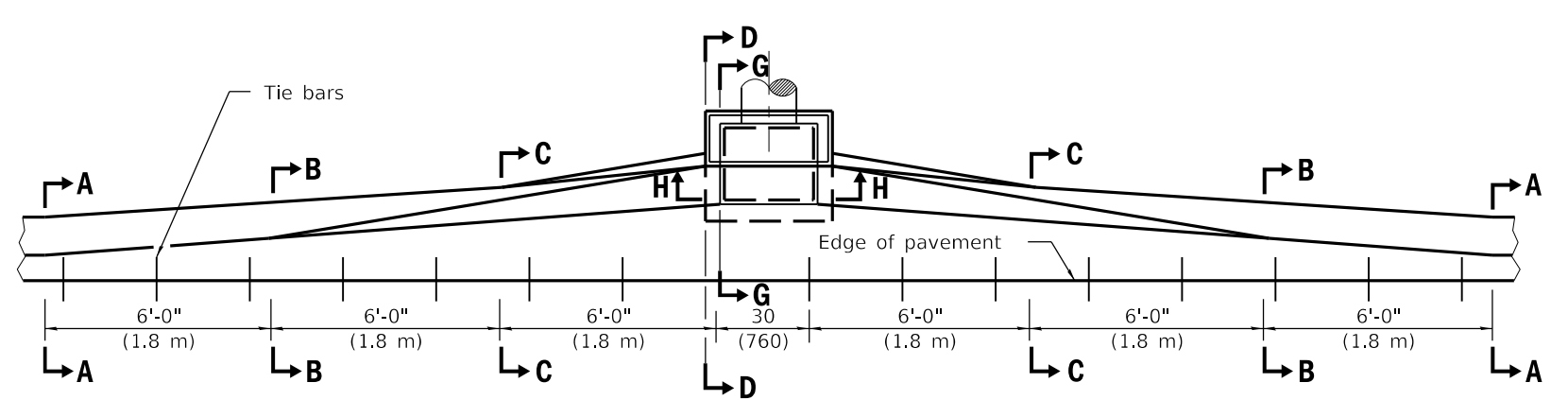

PLAN - DOUBLE OUTLET

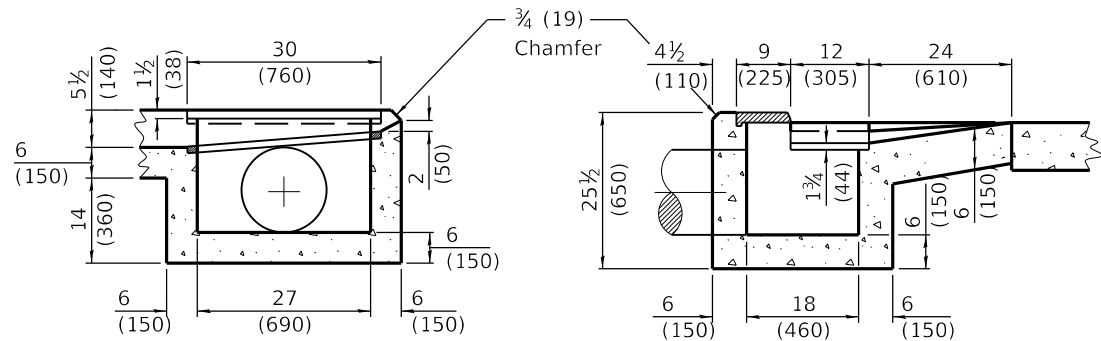

SECTION F-F

SECTION E-E

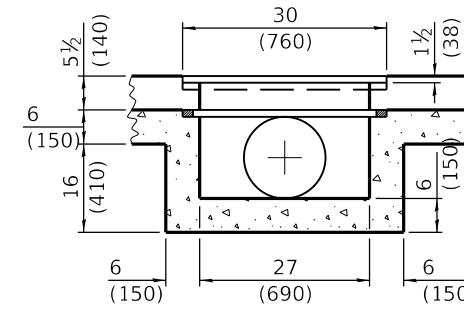

SECTION H-H

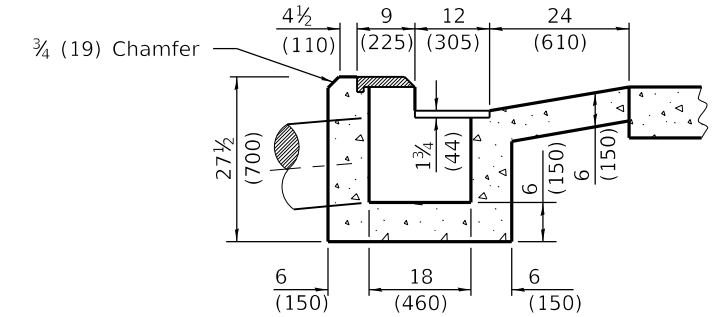

SECTION G-G

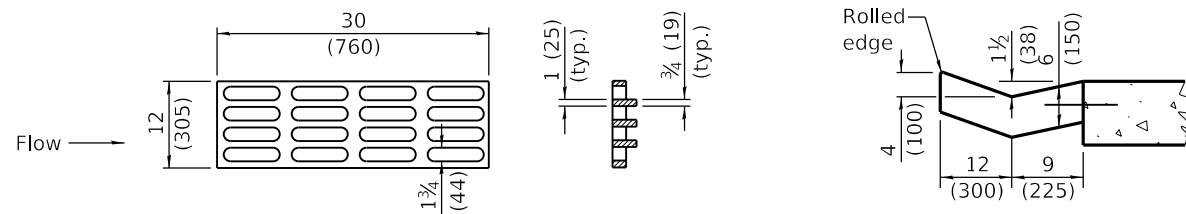

SECTION A-A

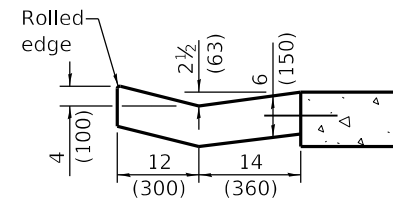

SECTION B-B

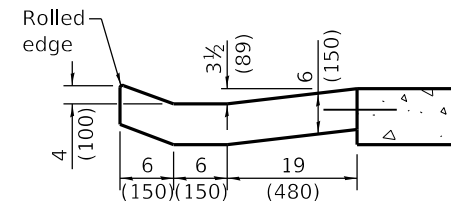

SECTION C-C

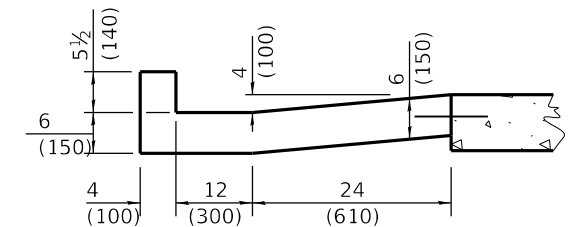

SECTION D-D

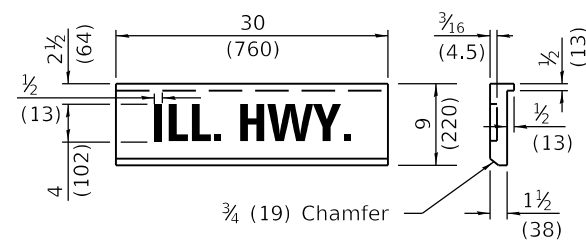
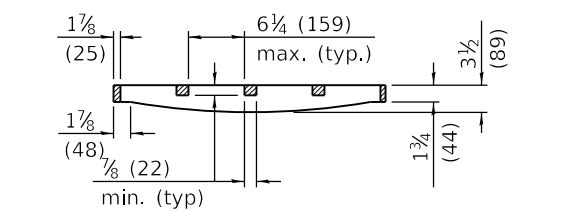

GRATE AND COVER TYPE 2B

QUANTITIES

Material	Single	Double
Concrete - cu. yd. (m ³)	1.62 (1.24)	2.18 (1.67)
Cast Iron Grate - Ea.	1	1
Cast Iron Cover - Ea.	1	1
Pipe Drain - Dia. in. (mm)	12 (300)	15 (375)

GENERAL NOTES

If the average grade of pavement for the distance A-E exceeds 2 percent, this distance shall be increased 6 ft. (1.8 m) for each 1 percent increase in grade.

The gutter outlet shall be tied to the pavement in accordance with details for longitudinal construction joint shown on Standard 420001.

All dimensions are in inches (millimeters) unless otherwise shown.

DATE	REVISIONS
1-1-18	Revised tie bar notes to be consistent with other gutter Highway Standards.
1-1-09	Switched units to English (metric).

OUTLETS TYPE 2 FOR TYPE B GUTTER

STANDARD 606211-04

Illinois Department of Transportation

PASSED January 1, 2018
Michael Beard
 ENGINEER OF POLICY AND PROCEDURES

APPROVED January 1, 2018
Maureen M. Beck
 ENGINEER OF DESIGN AND ENVIRONMENT

ISSUED 1-1-18

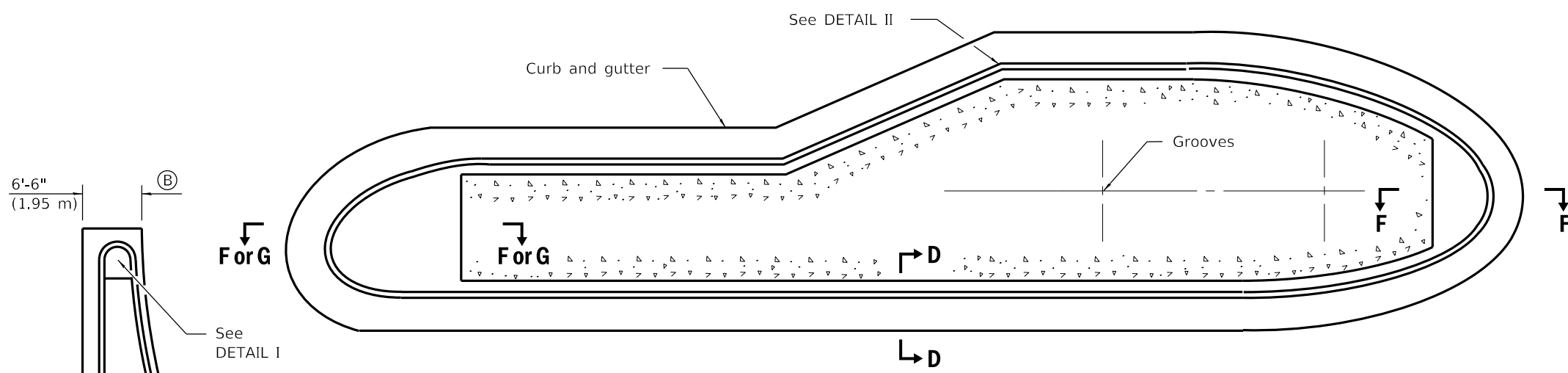

TYPICAL PLAN OF MEDIAN ISLAND
(SEE SHEET 2 FOR DETAILS OF RAMPED NOSES)

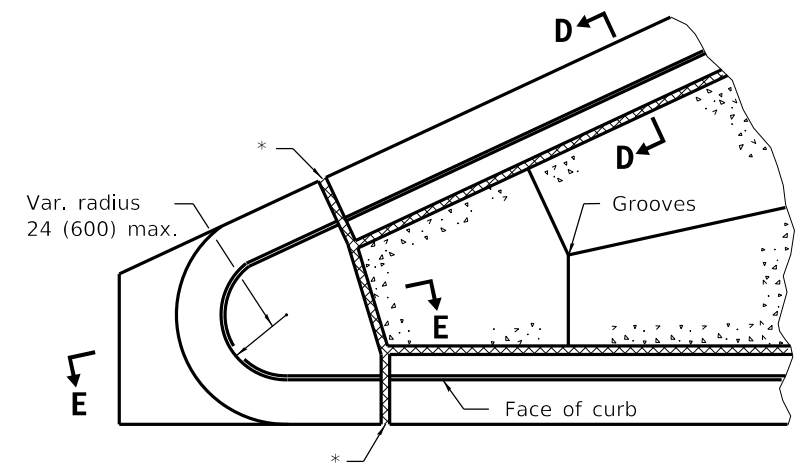

DETAIL I

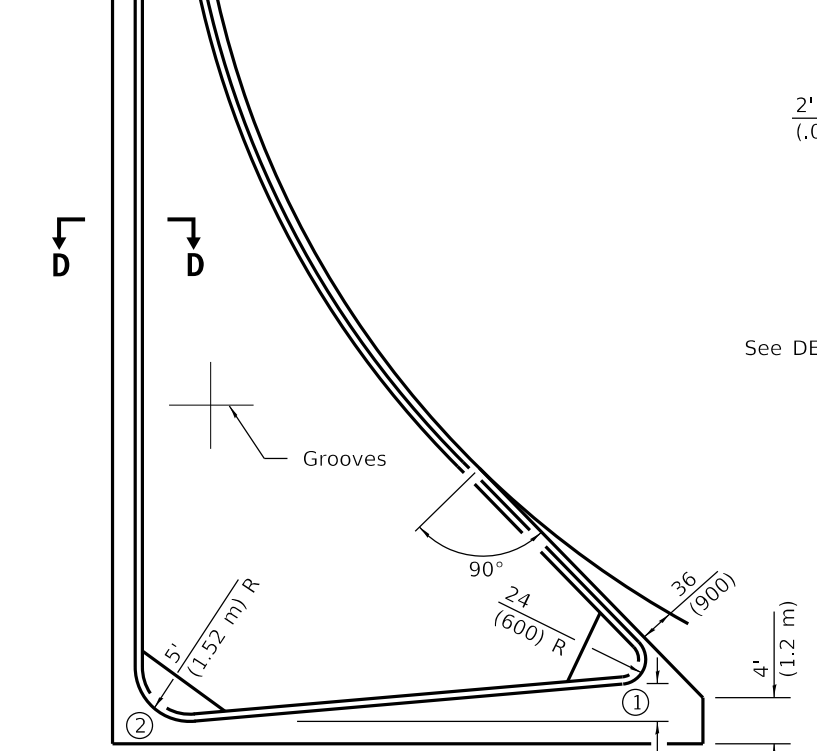

LARGE ISLAND
(FREE FLOW DESIGN)
36 (900) Offset for urban conditions

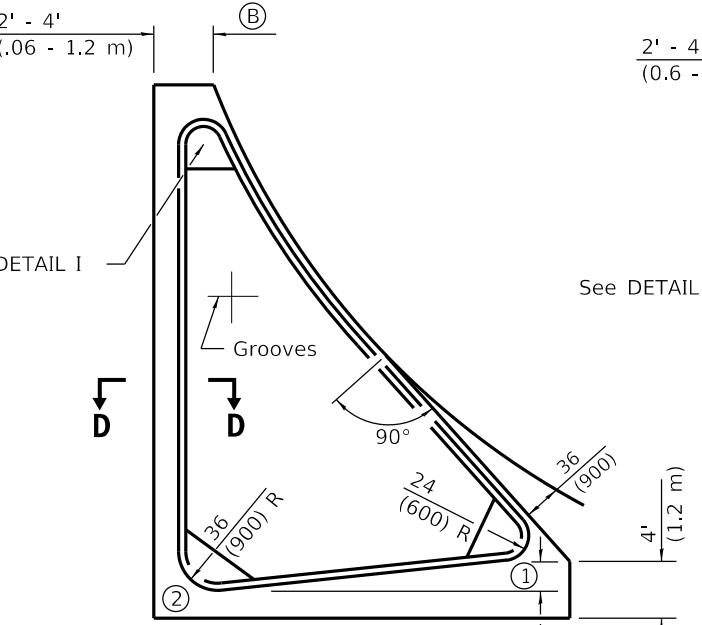

INTERMEDIATE ISLAND
(FOR RIGHT TURN LANE DESIGN)
24 (600) Offset for urban conditions

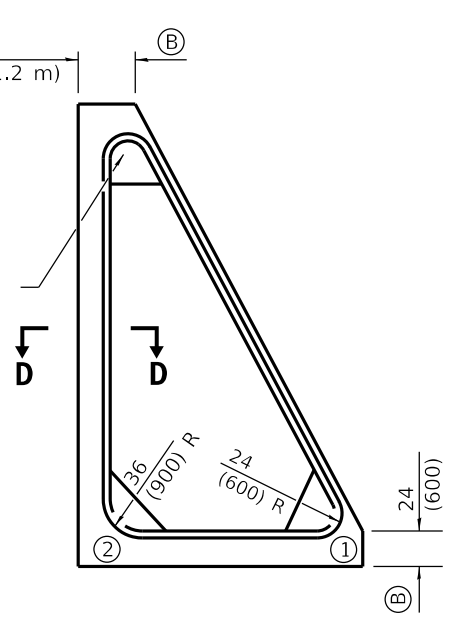

SMALL ISLAND

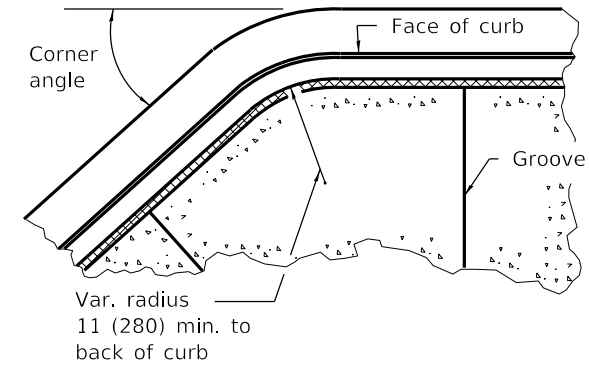

DETAIL II

Typical detail when corner angle is less than 90° and for other corners with radius greater than 24 (600).

TYPICAL PLANS OF CORNER ISLANDS

(SEE SHEET 2 FOR DETAILS OF RAMPED NOSES)

NOTE:
The blockouts (B) for the islands shall be extended so that the termination will line up with proposed or existing pavement joint.

Noses (1) and (2) shall be ramped unless noted otherwise on the plans. (See sheet 2 for length)

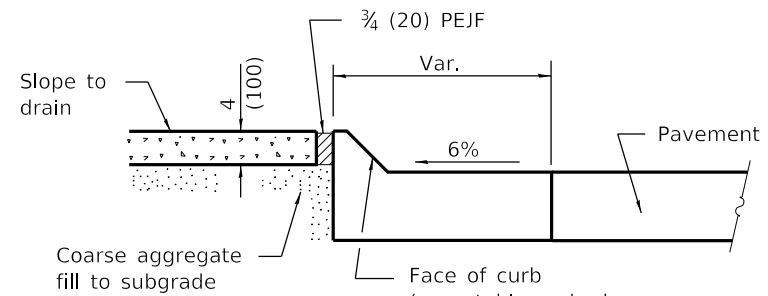

SECTION D-D

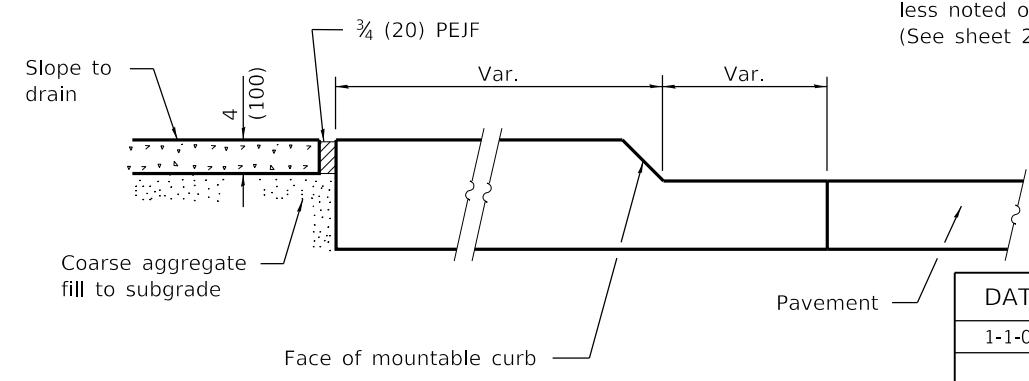

SECTION E-E

GENERAL NOTES

- PEJF = Preformed expansion joint filler.
- Median layout and radii shall be as shown on the plans.
- Keyed longitudinal construction joints shall be constructed without tie bars.
- See Standard 420001 and 606001 for details not shown.
- * ¾ (20) PEJF conforming to the full cross section of the curb, gutter and median surface.
- X = PCC base course plus HMA thickness.
- t = Pavement or pcc base course thickness.
- All dimensions are in inches (millimeters) unless otherwise shown.

DATE	REVISIONS
1-1-09	Switched units to English (metric).
1-1-07	Switched to Hot-Mix Asphalt (HMA) terminology.

PC CONCRETE ISLANDS AND MEDIANS

(Sheet 1 of 2)

STANDARD 606301-04

Illinois Department of Transportation

PASSED January 1, 2009

ENGINEER OF POLICY AND PROCEDURES

APPROVED January 1, 2009

ENGINEER OF DESIGN AND ENVIRONMENT

ISSUED 1-1-97

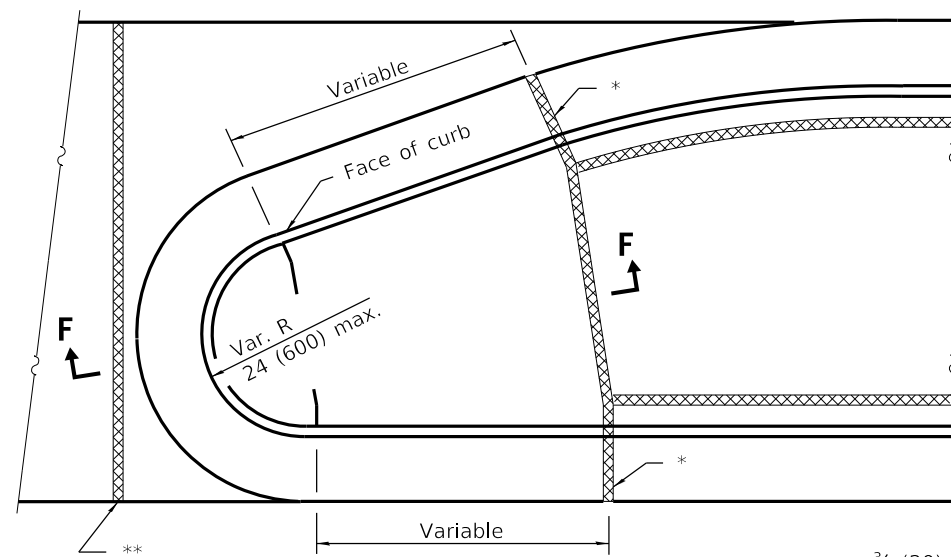

TYPE P MEDIAN SURFACE

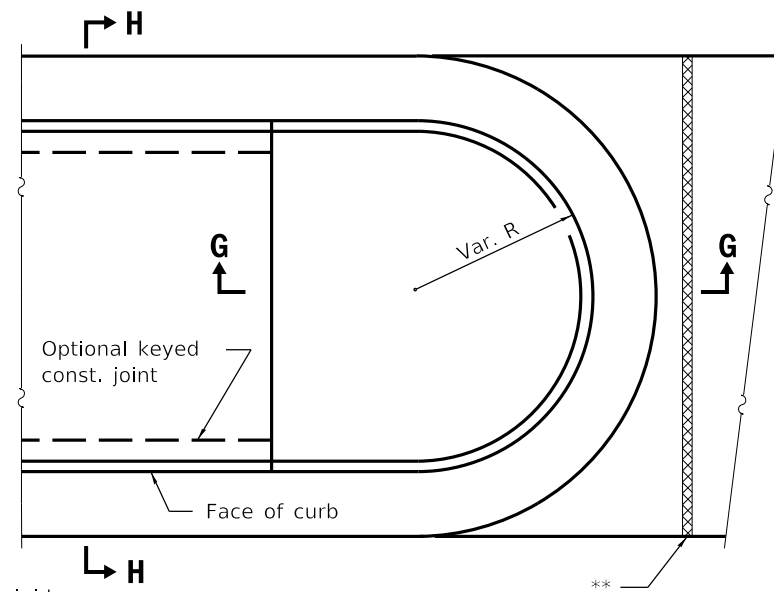

SOLID MEDIAN

TABLE OF DIMENSIONS					
TYPE SB MEDIANS					
TYPE	A	B	C	D	R ₁
SB-6.06	6	1	6	6	1
(SB-15.15)	(150)	(25)	(150)	(150)	(25)
SB-6.12	12	1	6	6	1
(SB-15.30)	(300)	(25)	(150)	(150)	(25)
SB-6.18	18	1	6	6	1
(SB-15.45)	(450)	(25)	(150)	(150)	(25)
SB-6.24	24	1	6	6	1
(SB-15.60)	(600)	(25)	(150)	(150)	(25)
SB-9.06	6	2	5	9	1
(SB-22.15)	(150)	(50)	(125)	(225)	(25)
SB-9.12	12	2	5	9	1
(SB-22.30)	(300)	(50)	(125)	(225)	(25)
SB-9.18	18	2	5	9	1
(SB-22.45)	(450)	(50)	(125)	(225)	(25)
SB-9.24	24	2	5	9	1
(SB-22.60)	(600)	(50)	(125)	(225)	(25)

TABLE OF DIMENSIONS					
TYPE M AND SM MEDIANS					
TYPE	A	B	C	D	R ₁
M-2.06	6	2	4	2	2
(M-5.15)	(150)	(50)	(100)	(50)	(50)
M-2.12	12	2	4	2	2
(M-5.30)	(300)	(50)	(100)	(50)	(50)
SM-4.06	6	4	3	4	3
(SM-10.15)	(150)	(100)	(75)	(100)	(75)
SM-4.12	12	4	3	4	3
(SM-10.30)	(300)	(100)	(75)	(100)	(75)
SM-4.18	18	4	3	4	3
(SM-10.45)	(450)	(100)	(75)	(100)	(75)
SM-4.24	24	4	3	4	3
(SM-10.60)	(600)	(100)	(75)	(100)	(75)
SM-6.06	6	6	2	6	2
(SM-15.15)	(150)	(150)	(50)	(150)	(50)
SM-6.12	12	6	2	6	2
(SM-15.30)	(300)	(150)	(50)	(150)	(50)
SM-6.18	18	6	2	6	2
(SM-15.45)	(450)	(150)	(50)	(150)	(50)
SM-6.24	24	6	2	6	2
(SM-15.60)	(600)	(150)	(50)	(150)	(50)

** 3/4 (20) PEJF between rigid pavement and median end. Align with joint in adjacent pavement.

PLAN
(RAMPED NOSES)

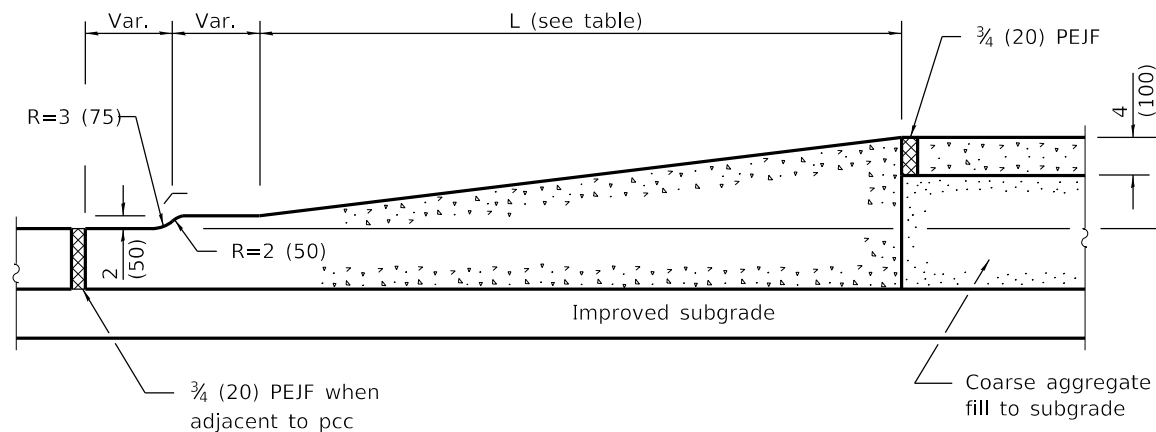

SECTION F-F

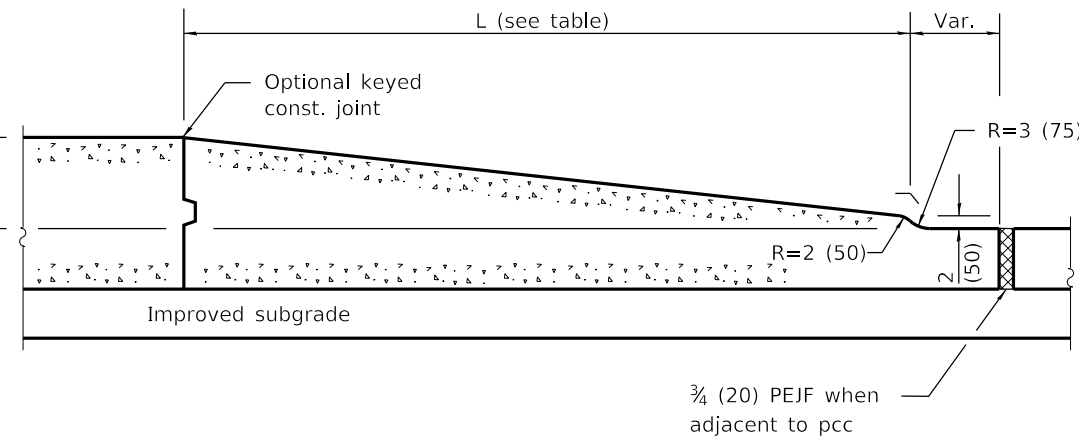

SECTION G-G

TABLE OF RAMPED NOSE LENGTHS	
TYPE OF NOSE	L
Median	6' (1.8 m)
Small Island	24 (600)
Intermediate Island	4' (1.2 m)
Large Island	6' (1.8 m)

NOTE
R₂ is applicable to M-2 (M-5) type only

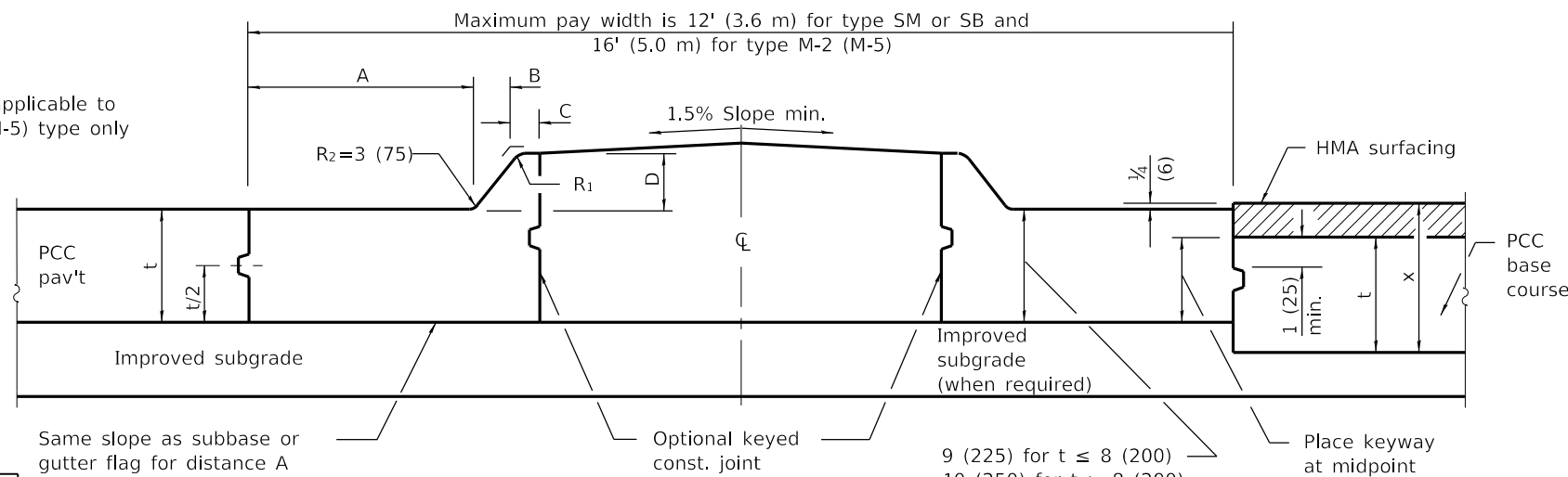

HALF SECTION FOR PCC PAVEMENT

HALF SECTION FOR PCC BASE COURSE

SECTION H-H
(TYPE SM, SB & M-5 (M-2) MEDIANS)

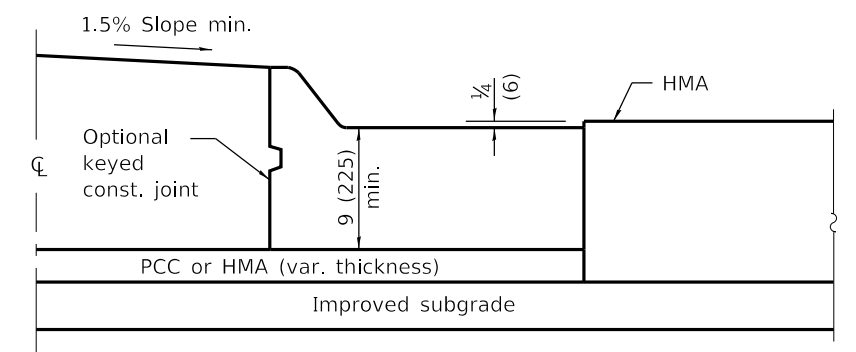

HALF SECTION FOR FLEXIBLE PAVEMENT

Illinois Department of Transportation

PASSED January 1, 2009

ENGINEER OF POLICY AND PROCEDURES

APPROVED January 1, 2009

ENGINEER OF DESIGN AND ENVIRONMENT

ISSUED 1-1-97

PC CONCRETE ISLANDS AND MEDIANS

(Sheet 2 of 2)

STANDARD 606301-04

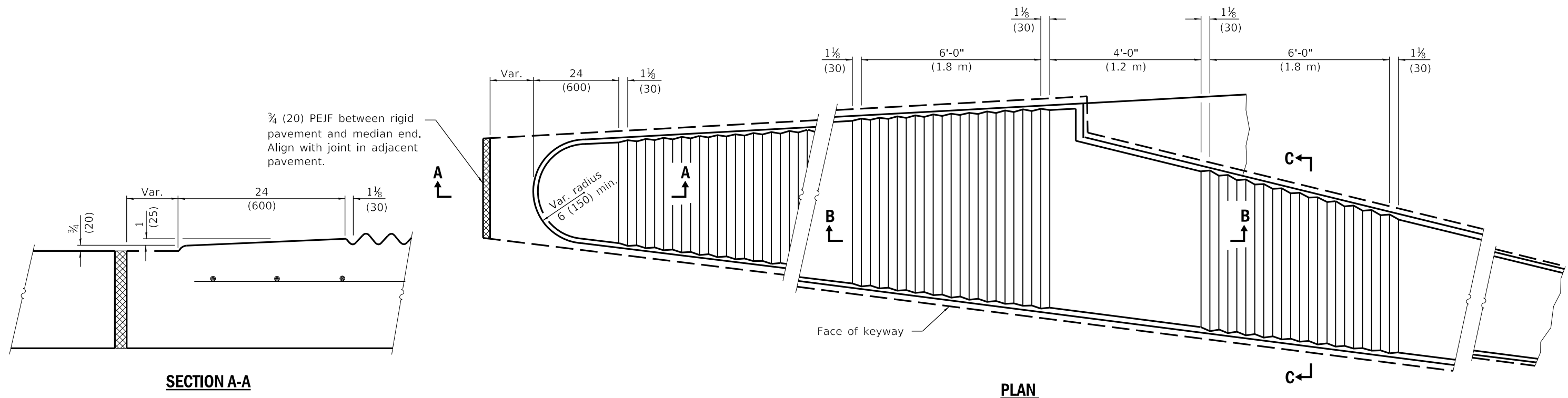

SECTION A-A

PLAN

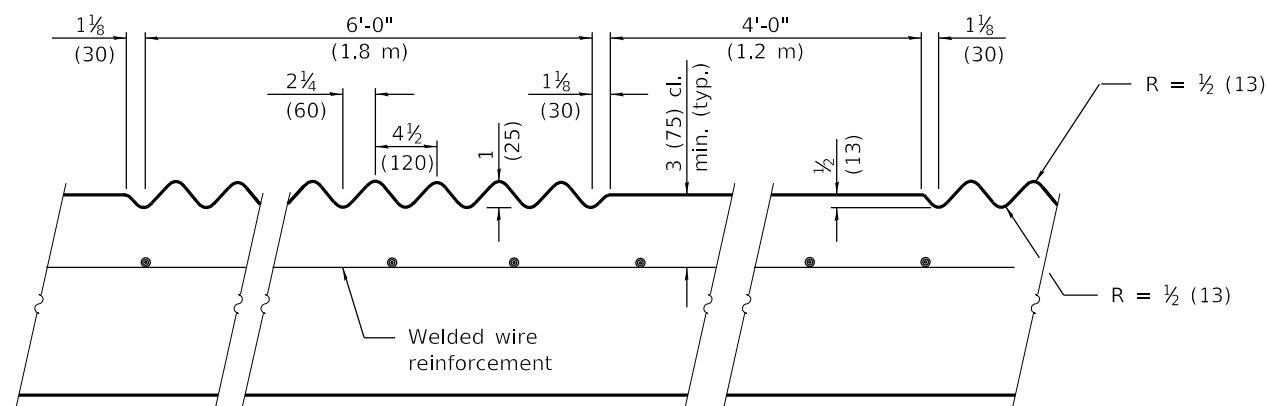

SECTION B-B

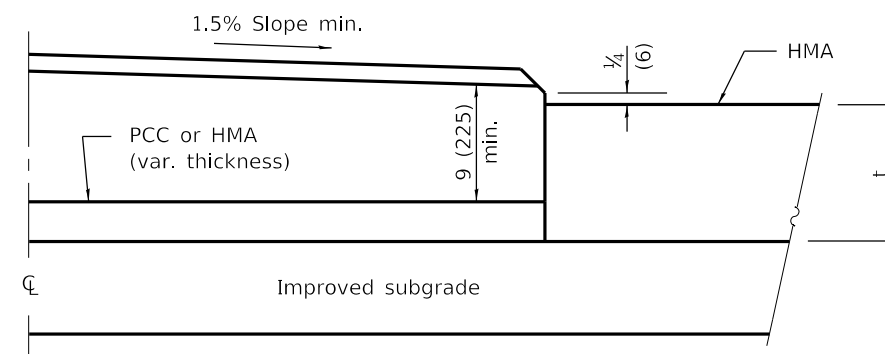

HALF SECTION FOR FLEXIBLE PAVEMENT SECTION C-C

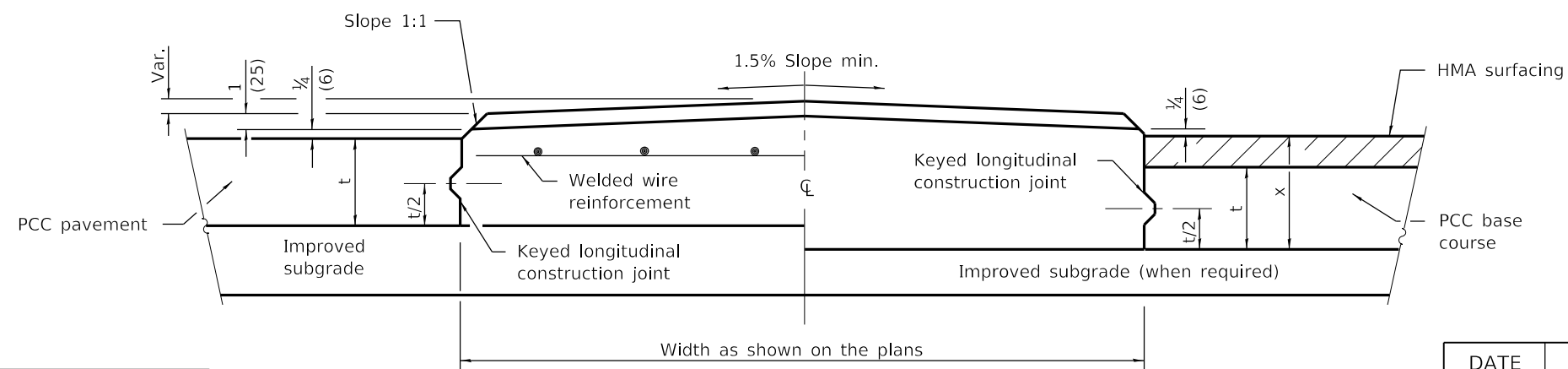

HALF SECTION FOR PCC PAVEMENT SECTION C-C

SECTION C-C

HALF SECTION FOR PCC BASE COURSE SECTION C-C

GENERAL NOTES

- PEJF = Preformed expansion joint filler.
- Median layout and radii shall be as shown on the plans.
- Keyed longitudinal construction joints shall be constructed without tie bars.
- X = PCC base course plus HMA thickness.
- t = Pavement or pcc base course thickness.
- Welded wire reinforcement required for medians built contiguous to reinforced pcc pavement only.
- See Standards 420001 and 420701 for details not shown.
- All dimensions are in inches (millimeters) unless otherwise shown.

Illinois Department of Transportation

PASSED Michael Beard April 1, 2016
ENGINEER OF POLICY AND PROCEDURES

APPROVED [Signature] April 1, 2016
ENGINEER OF DESIGN AND ENVIRONMENT

ISSUED 1-1-97 76-T 03/05

DATE	REVISIONS
4-1-16	Changed terminology to 'welded wire reinforcement'.
1-1-09	Switched units to English (metric).

CORRUGATED PC CONCRETE MEDIANS

STANDARD 606306-04

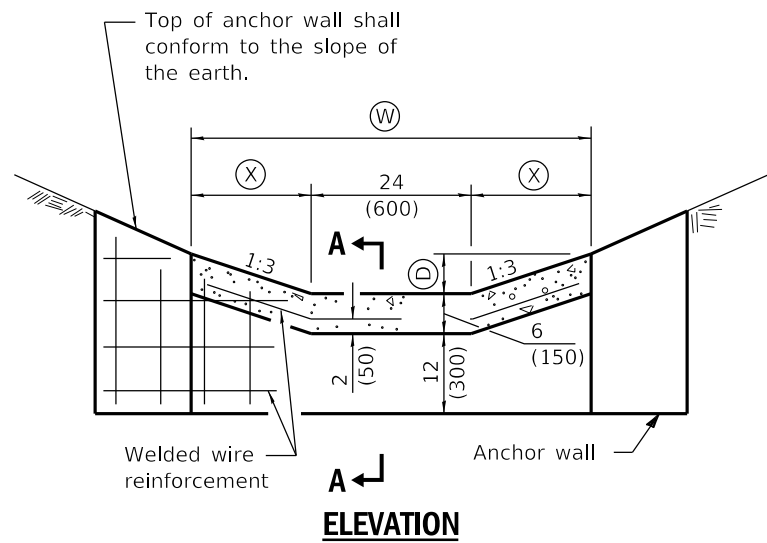

TABLE FOR PAVED DITCH TYPE A

TYPE	(D)	(W)	(X)	Flow Area sq. ft. (m ²)	Conc. Area sq. yd. (m ²)
A-15	6 (150)	5'-0" (1.5 m)	18 (450)	1.75 (0.175)	0.278 (0.225)
A-22	9 (225)	6'-6" (1.95 m)	27 (675)	3.19 (0.287)	0.361 (0.293)
A-30	12 (300)	8'-0" (2.4 m)	36 (900)	5.00 (0.450)	0.444 (0.360)
A-37	15 (375)	9'-6" (2.85 m)	3'-9" (1.12 m)	7.19 (0.645)	0.528 (0.426)
A-45	18 (450)	11'-0" (3.3 m)	4'-6" (1.35 m)	9.75 (0.877)	0.611 (0.495)
A-52	21 (525)	12'-6" (3.75 m)	5'-3" (1.58 m)	12.69 (1.144)	0.694 (0.564)
A-60	24 (600)	14'-0" (4.2 m)	6'-0" (1.8 m)	16.00 (1.440)	0.778 (0.630)

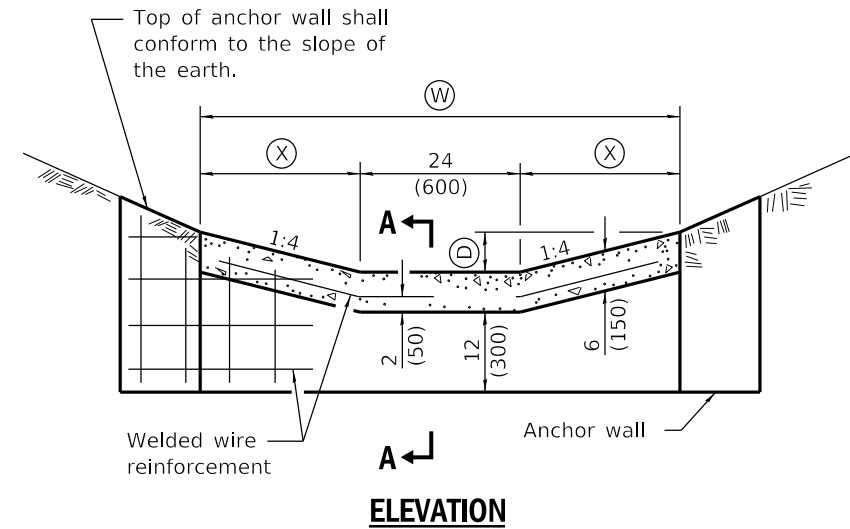
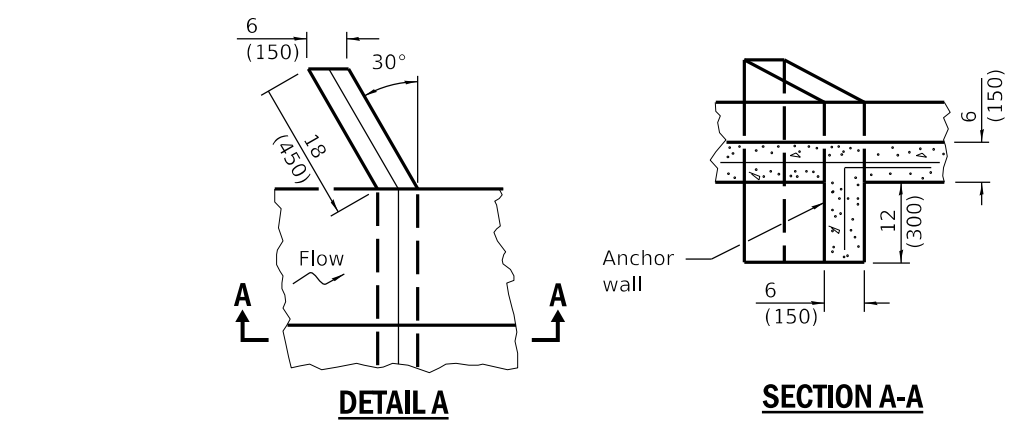
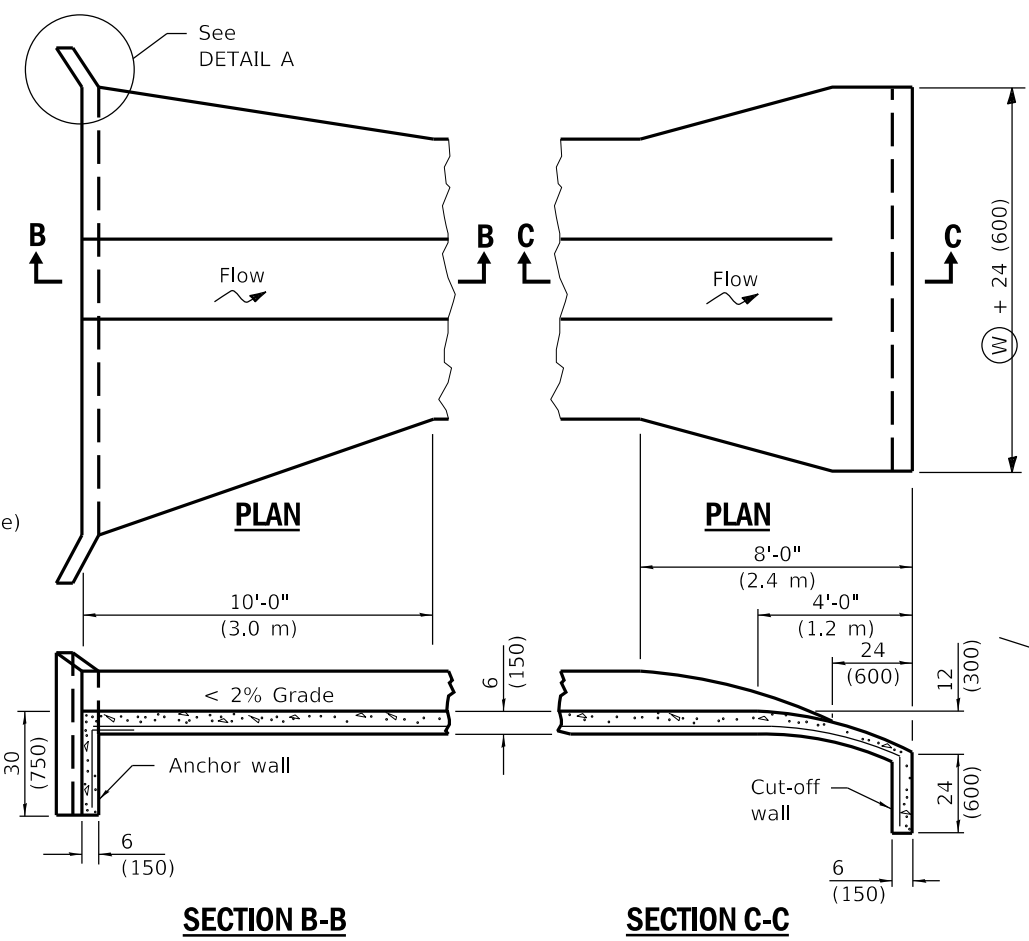
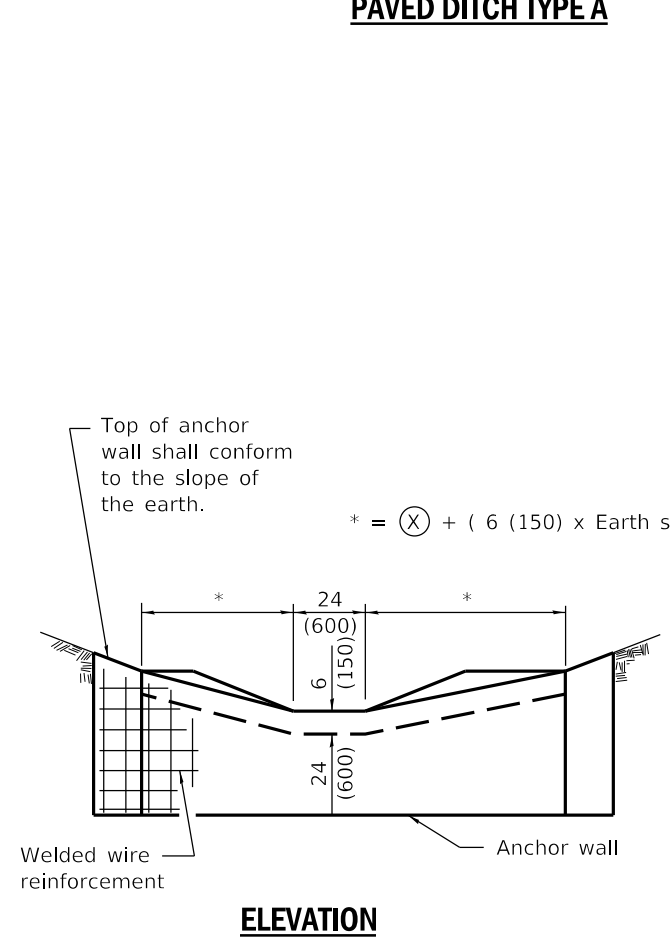

TABLE FOR PAVED DITCH TYPE B

TYPE	(D)	(W)	(X)	Flow Area sq. ft. (m ²)	Conc. Area sq. yd. (m ²)
B-15	6 (150)	6'-0" (1.8 m)	24 (600)	2.00 (0.180)	0.333 (0.270)
B-22	9 (225)	8'-0" (2.4 m)	36 (900)	3.75 (0.337)	0.444 (0.360)
B-30	12 (300)	10'-0" (3.0 m)	4'-0" (1.2 m)	6.00 (0.540)	0.555 (0.450)
B-37	15 (375)	12'-0" (3.6 m)	5'-0" (1.5 m)	8.75 (0.787)	0.667 (0.540)
B-45	18 (450)	14'-0" (4.2 m)	6'-0" (1.8 m)	12.00 (1.080)	0.778 (0.630)
B-52	21 (525)	16'-0" (4.8 m)	7'-0" (2.1 m)	15.75 (1.417)	0.889 (0.720)
B-60	24 (600)	18'-0" (5.4 m)	8'-0" (2.4 m)	20.00 (1.800)	1.000 (0.810)

PAVED DITCH TYPE A

PAVED DITCH TYPE B



DETAIL OF ANCHOR WALL

DETAIL OF UPSTREAM END

DETAIL OF DOWNSTREAM END

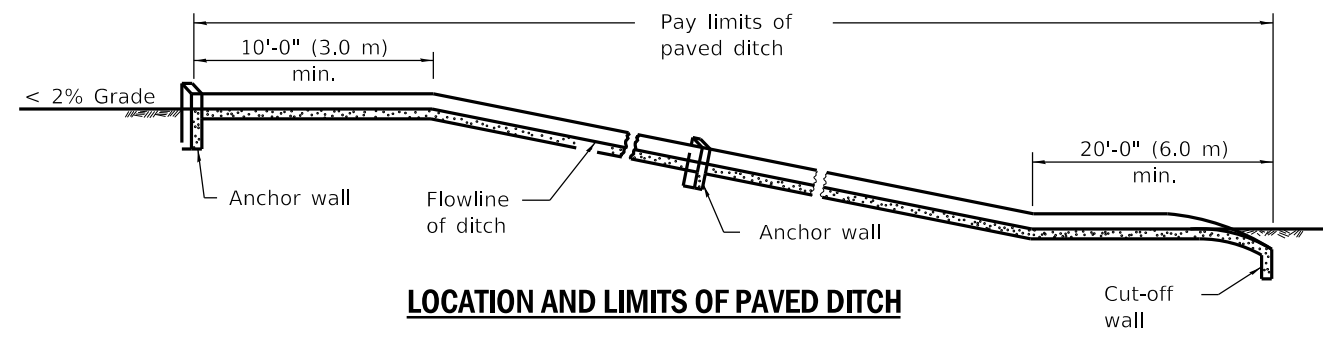

GENERAL NOTES

All slopes are expressed as of vertical displacement to units of horizontal displacement (V:H).

All dimensions are in inches (millimeters) unless otherwise shown.

DATE	REVISIONS
4-1-16	Changed terminology to 'welded wire reinforcement'.
1-1-09	Switched units to English (metric).

PAVED DITCH

STANDARD 606401-02

Illinois Department of Transportation

PASSED Michael Beard April 1, 2016
ENGINEER OF POLICY AND PROCEDURES

APPROVED [Signature] April 1, 2016
ENGINEER OF DESIGN AND ENVIRONMENT

ISSUED 1-1-99

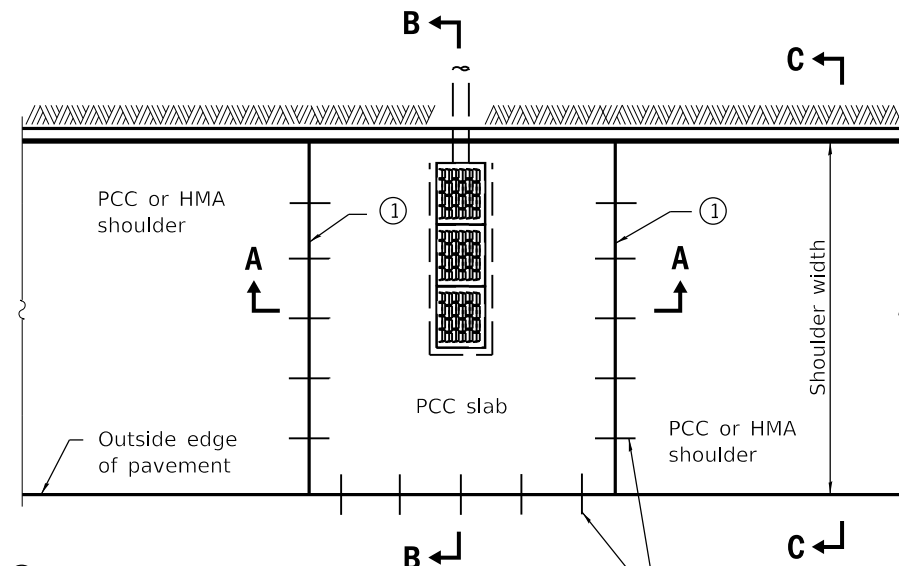

① Joints in prolongation with existing joints in pavements.

PLAN

No. 6x30 (No. 19x750)
Tie bars or expansion
anchor ties at 36 (900) cts.

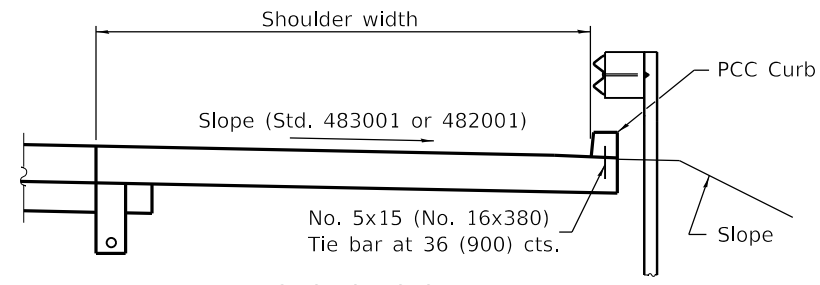

SECTION C-C

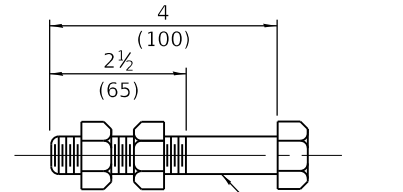

ANCHOR BOLT

(Used to tie pipe to concrete collar)

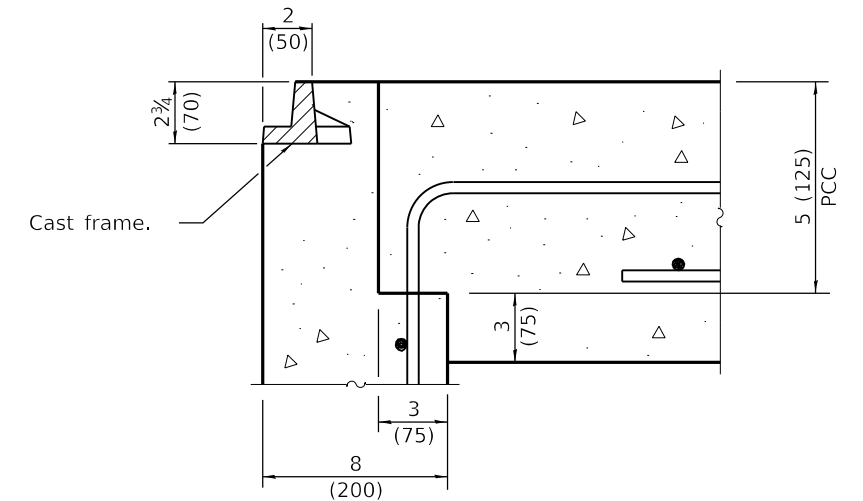

DETAIL A

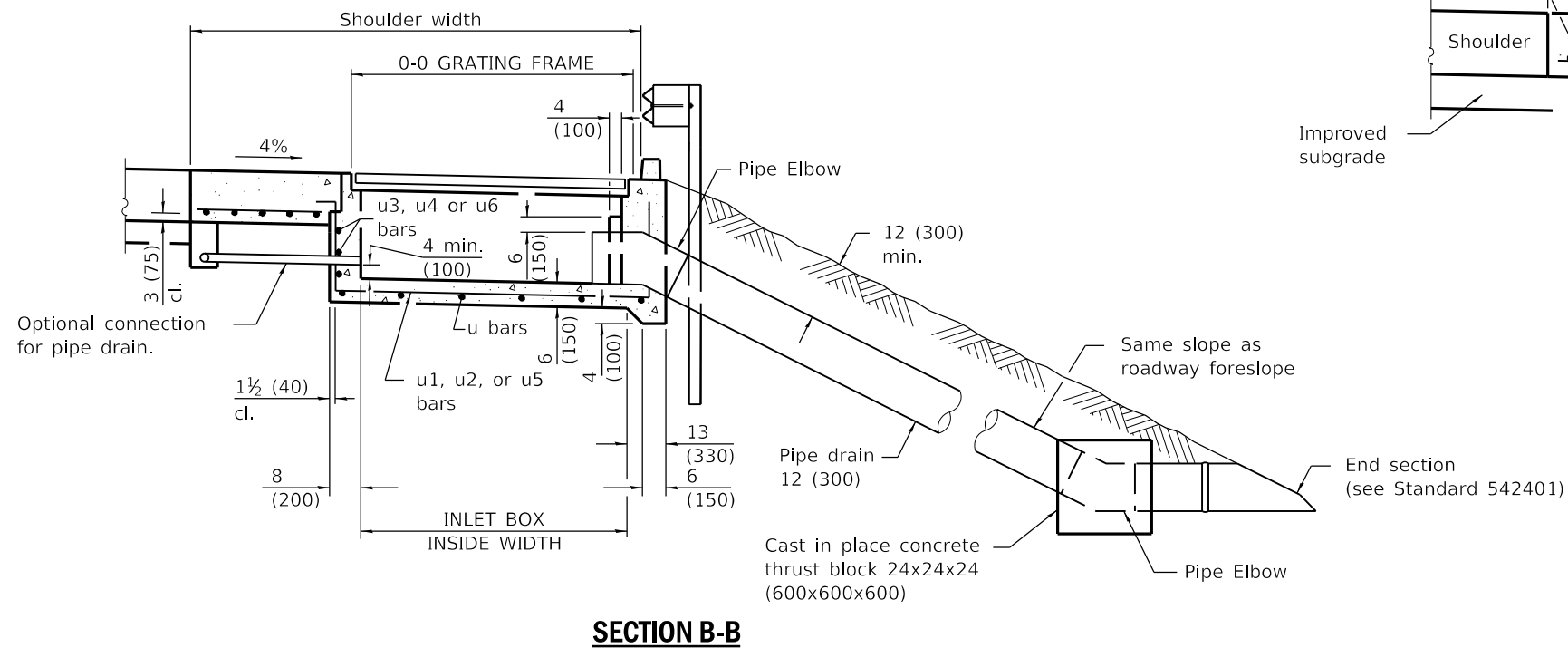

SECTION B-B

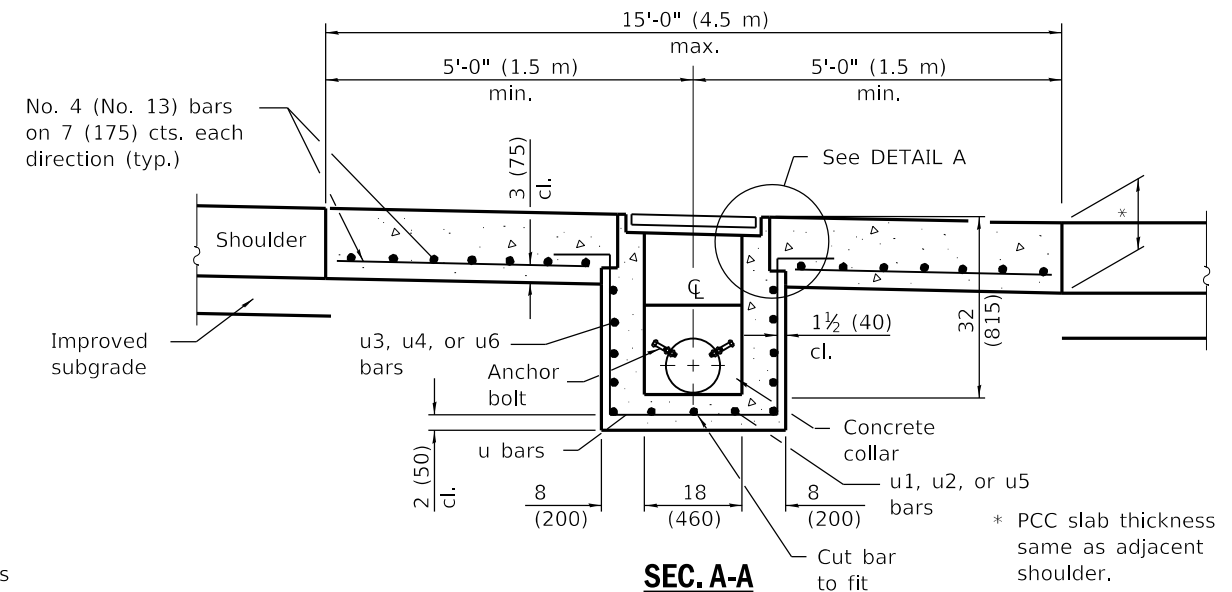

SEC. A-A

GENERAL NOTES

See Standard 420001 for joint details not shown.

See Standard 630001 for details of guardrail not shown.

All exposed edges of the inlet, except the upper perimeter, shall be beveled 3/4 (20).

For placement of drainage elements on existing construction with existing rigid pavement, substitute expansion anchor ties for tie bars. For nonrigid pavements or monolithic construction of PCC slab and shoulder, omit tie bars.

All dimensions are in inches (millimeters) unless otherwise shown.

SHOULDER INLET WITH CURB

(Sheet 1 of 2)

STANDARD 610001-09

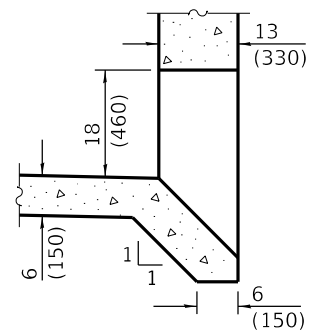

BOX OUTLET WHEN PRECAST

INLET TYPE	SHOULDER WIDTH	O-O GRATING FRAME	INLET BOX INSIDE WIDTH	INLET BOX INSIDE LENGTH
Type E	8' (2.4 m)	4'-4" (1.325 m)	3'-11" (1.195 m)	18 (460)
Type F	10' (3.0 m)	6'-5" (1.960 m)	6'-0" (1.830 m)	18 (460)
Type G	5' (1.5 m) or less	27 (690)	22 (560)	18 (460)

DATE	REVISIONS
1-1-21	Revised Section B-B, precast box outlet, anchor bolts, rebar and curb details. Added pipe elbows and WWR note.
1-1-18	Changed tie bar spacing to 36 (900) cts.

Illinois Department of Transportation

PASSED January 1, 2021
Michael Bond
 ENGINEER OF POLICY AND PROCEDURES

APPROVED January 1, 2021
J. E. C.
 ENGINEER OF DESIGN AND ENVIRONMENT

ISSUED 1-1-97

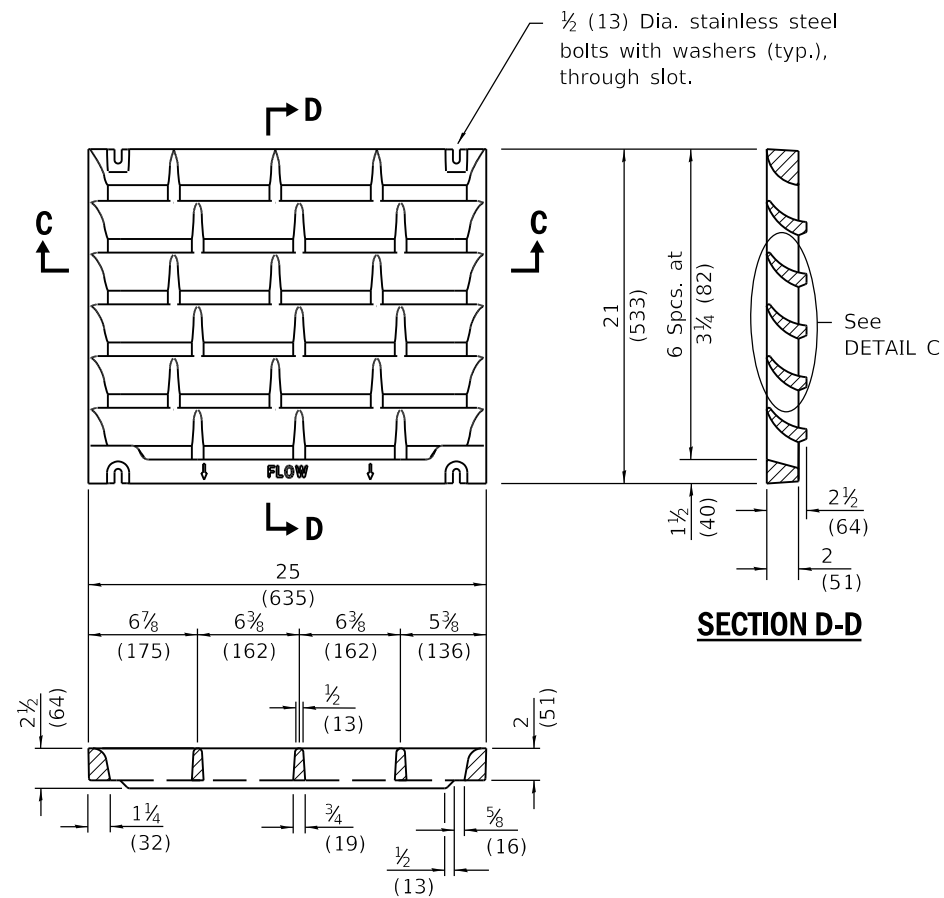

SECTION C-C

DETAIL OF CAST GRATE

Type G requires 1 grate
 Type E requires 2 grates
 Type F requires 3 grates

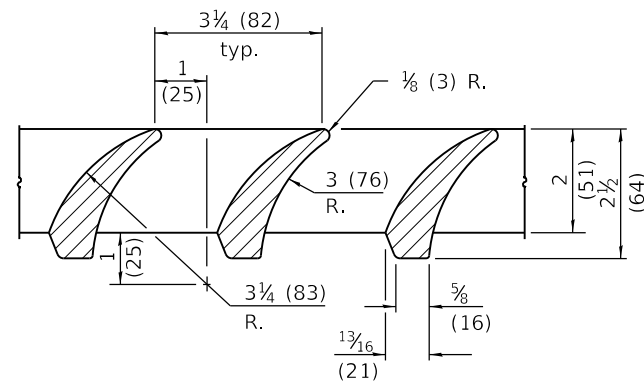

DETAIL C

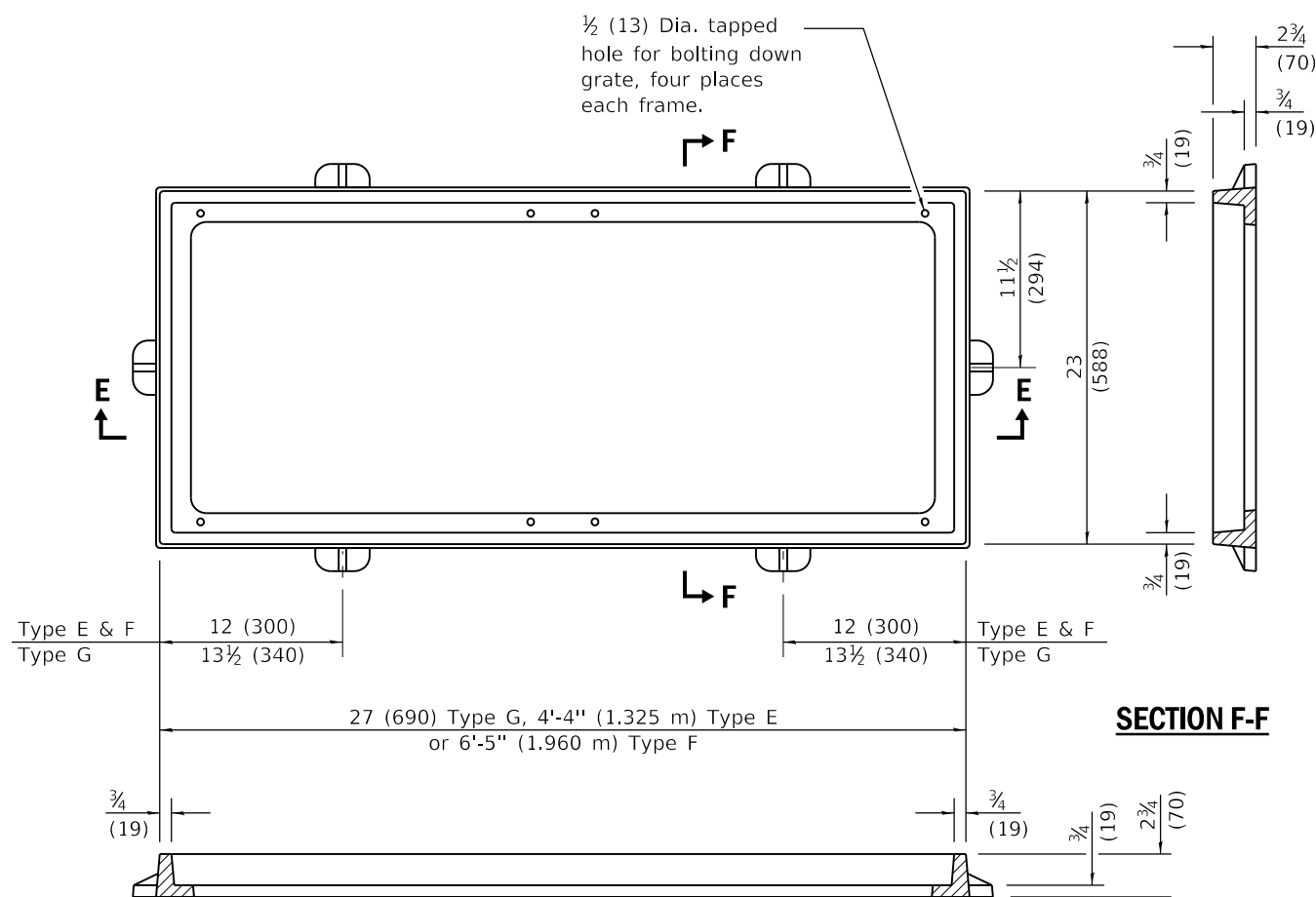

SECTION E-E

DETAIL OF CAST FRAME
 (Type E shown)

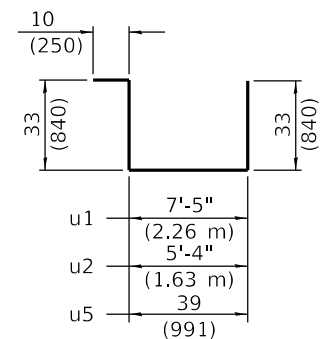
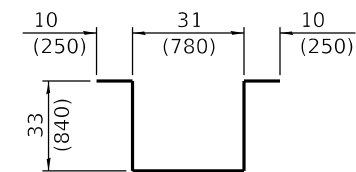

BARS u1, u2, & u5

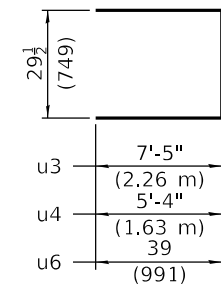

BARS u3, u4 & u6

INLET BOX

REQUIRED MATERIAL			
TYPE F			
Bar	Qty.	Size	Length
u	8	No. 4 (No.13)	9'-9" (2.96 m)
u1	3	No. 4 (No.13)	13'-9" (4.19 m)
u3	4	No. 4 (No.13)	17'-3 1/2" (5.27 m)
Concrete	cu. yds. (m³)		1.7 (1.3)
Reinf. bars	lbs. (kg)		126 (57.2)
Grating	sq. ft. (m²)		10.9 (1.02)
TYPE E			
Bar	Qty.	Size	Length
u	6	No. 4 (No.13)	9'-9" (2.96 m)
u2	3	No. 4 (No.13)	11'-8" (3.56 m)
u4	4	No. 4 (No.13)	13'-1 1/2" (4.00 m)
Concrete	cu. yds. (m³)		1.3 (1.0)
Reinf. bars	lbs. (kg)		98 (44.5)
Grating	sq. ft. (m²)		7.3 (0.68)
TYPE G			
Bar	Qty.	Size	Length
u	4	No. 4 (No.13)	9'-9" (2.69 m)
u5	3	No. 4 (No.13)	9'-7" (2.92 m)
u6	4	No. 4 (No.13)	8'-11 1/2" (2.73 m)
Concrete	cu. yds. (m³)		0.5 (0.4)
Reinf. bars	lbs. (kg)		70 (31.8)
Grating	sq. ft. (m²)		3.6 (0.34)

NOTES

Welded wire reinforcement (WWR) may be used in lieu of reinforcement bars. Only one layer of WWR is permitted to avoid congestion.

SHOULDER INLET WITH CURB

(Sheet 2 of 2)

STANDARD 610001-09

Illinois Department of Transportation

PASSED January 1, 2021
Michael Bond
 ENGINEER OF POLICY AND PROCEDURES

APPROVED January 1, 2021
J. E. ...
 ENGINEER OF DESIGN AND ENVIRONMENT

ISSUED 1-1-97

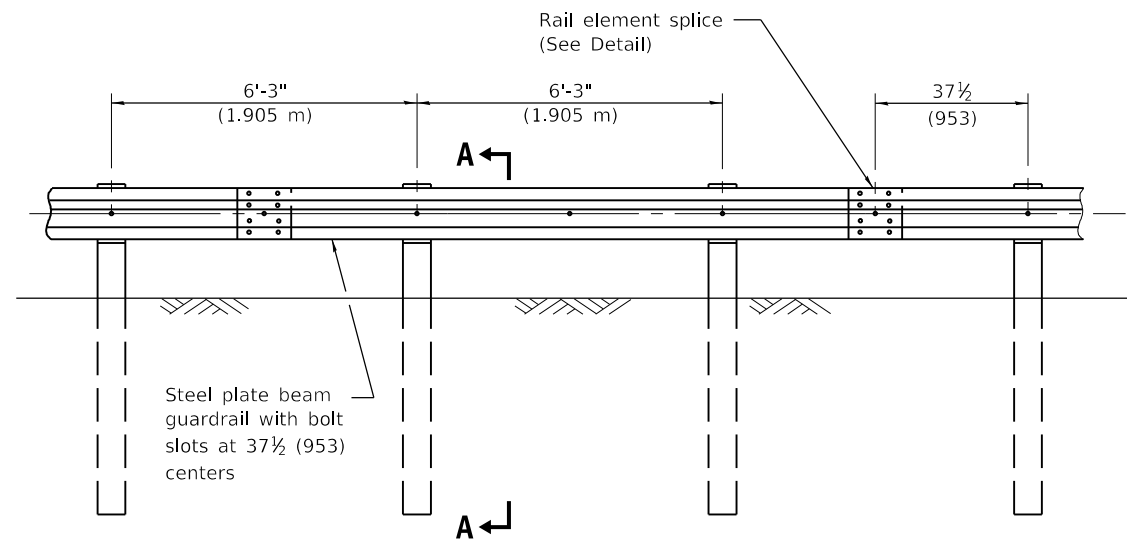

ELEVATION

TYPE A

6'-3" (1.905 m) Typical post spacing

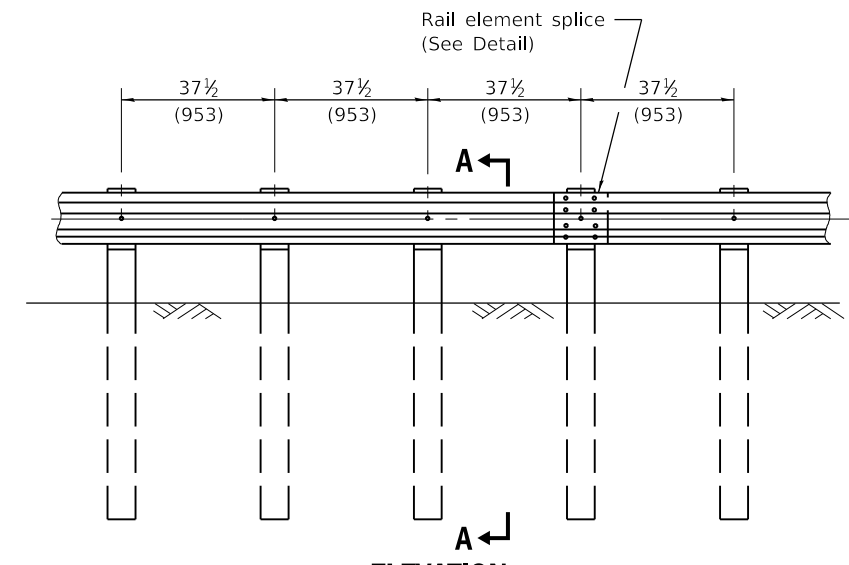

ELEVATION

TYPE B

37 1/2 (953) Closed post spacing

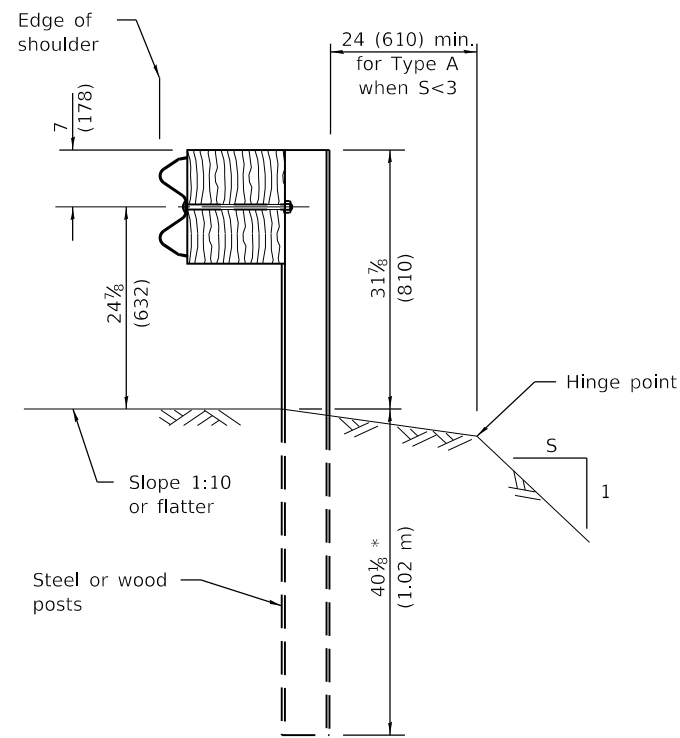

SECTION A-A

* When "S" is less than 3 and the distance from the back of post is less than 24 (610), the post shall be steel and the embedment shall be 76 1/8 (1.93 m) and the minimum top of rail height shall be 31 (787).

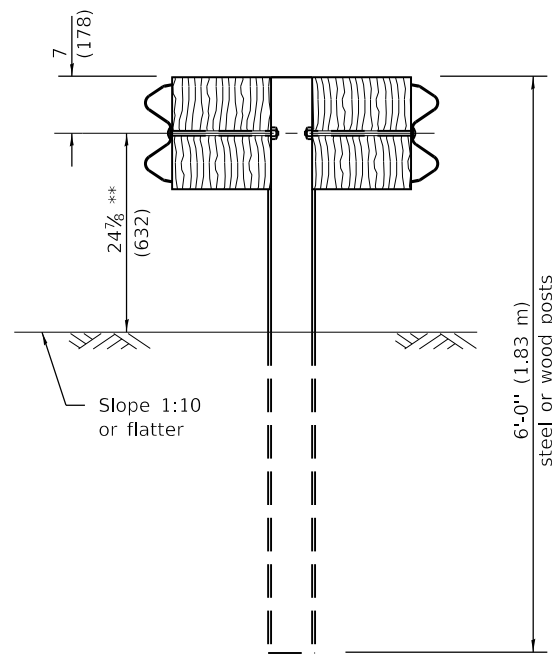

SECTION B-B

** When connecting Type D guardrail to an impact attenuator, adjust this dimension to match over a distance of 25'-0" (7.62 m) from point of connection if necessary.

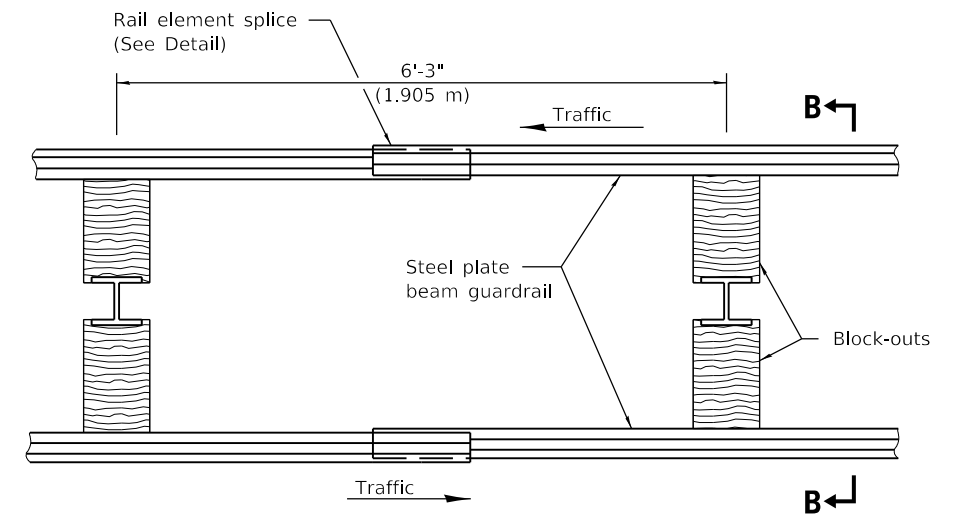

PLAN

TYPE D

Double steel plate beam guardrail
6'-3" (1.905 m) typical post spacing

GENERAL NOTES

All slope ratios are expressed as units of vertical displacement to units of horizontal displacement (V:H).

All dimensions are in inches (millimeters) unless otherwise shown.

Illinois Department of Transportation

APPROVED January 1, 2018
Michael Beard
ENGINEER OF POLICY AND PROCEDURES

APPROVED January 1, 2018
Marcus M. Beck
ENGINEER OF DESIGN AND ENVIRONMENT

ISSUED 1-1-97

DATE	REVISIONS
1-1-18	Revised steel post to have four holes in each flange.
1-1-17	Added detail for leave-out.
	Rev. 'D' to less than 6 (150) for guardrail behind curb.

STEEL PLATE BEAM GUARDRAIL

(Sheet 1 of 4)

STANDARD 630001-12

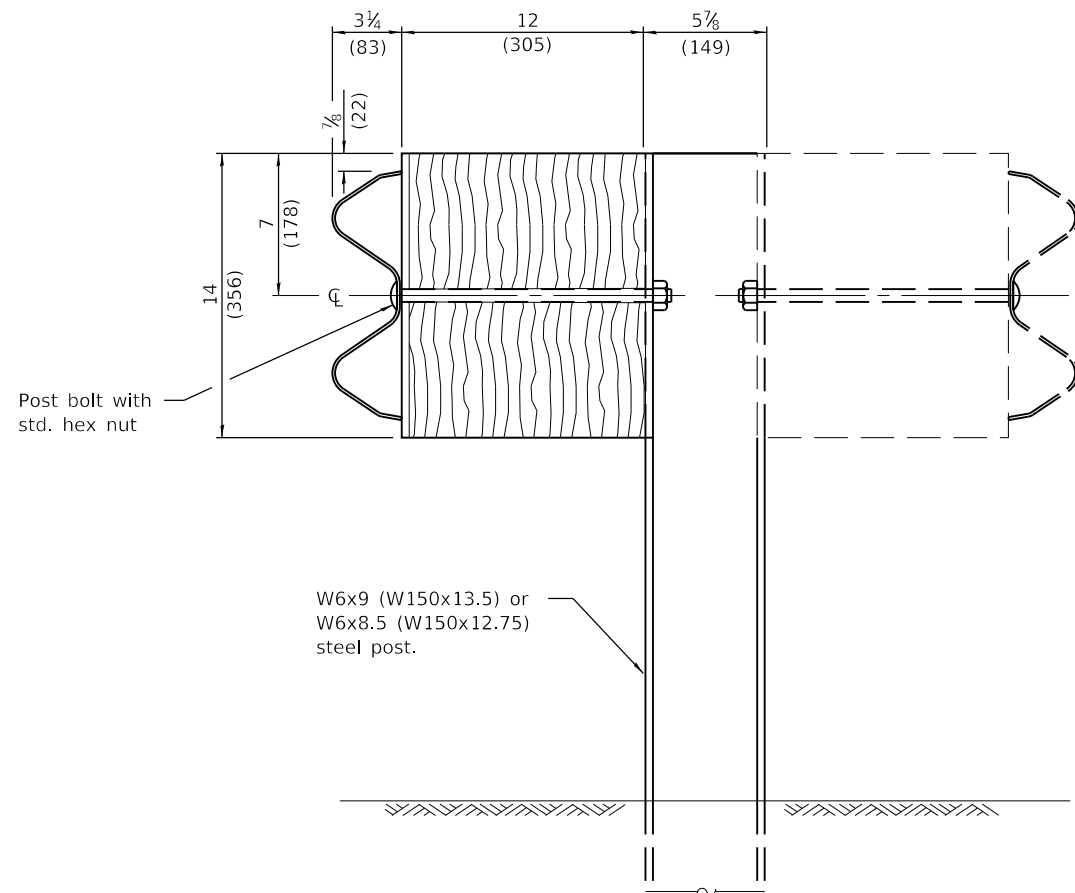

STEEL POST CONSTRUCTION

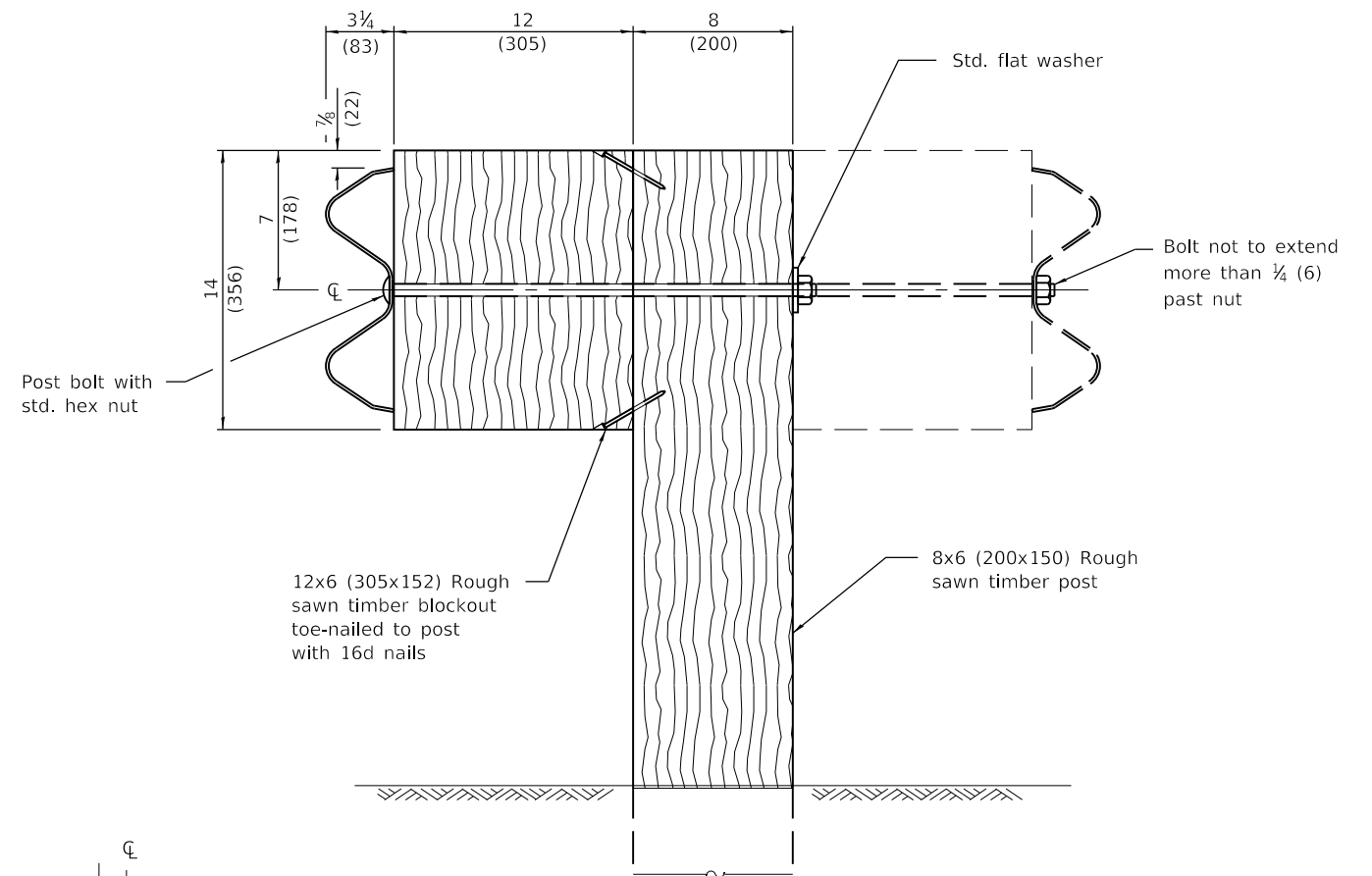

WOOD POST CONSTRUCTION

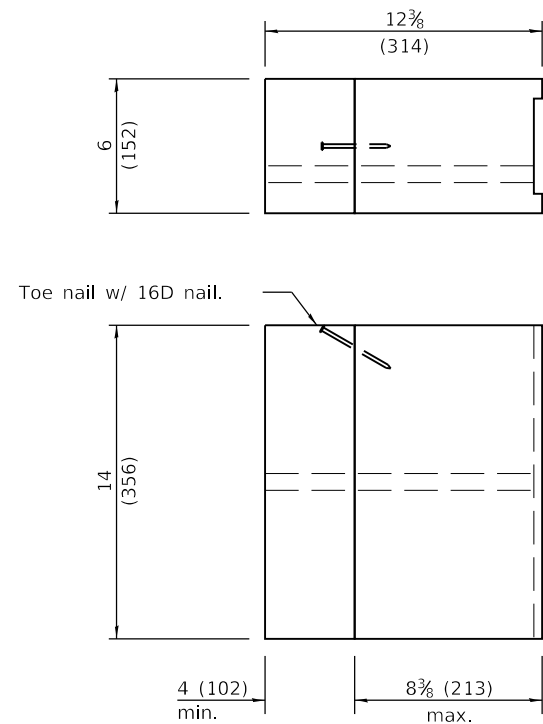

TWO-PIECE WOOD BLOCKOUT OPTION

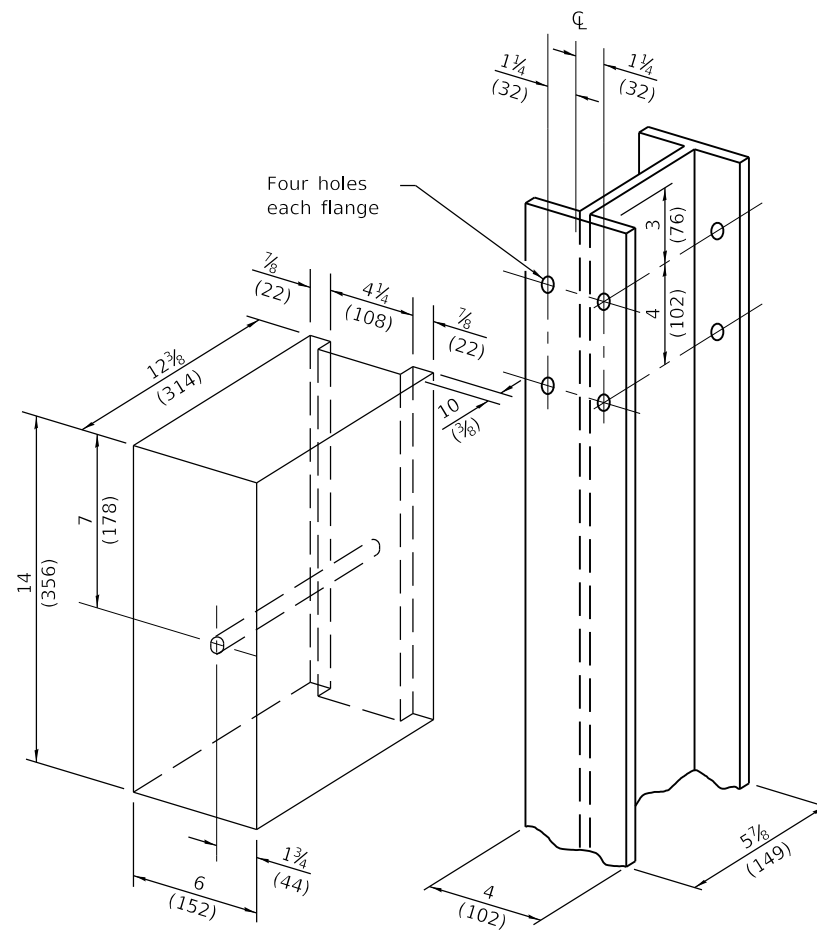

Note:
All holes 3/4 (20) dia.

WOOD BLOCK-OUT AND STEEL POST DETAILS

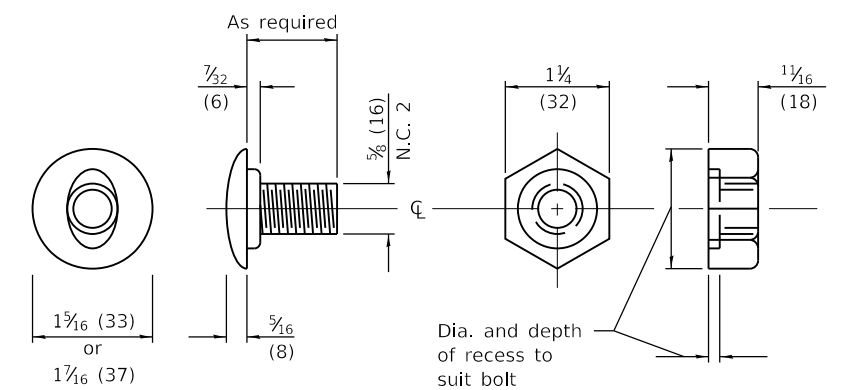

POST OR SPLICE BOLT & NUT

Illinois Department of Transportation

APPROVED January 1, 2018
Michael Beard
ENGINEER OF POLICY AND PROCEDURES

APPROVED January 1, 2018
Marcus M. Beck
ENGINEER OF DESIGN AND ENVIRONMENT

ISSUED 1-1-18

STEEL PLATE BEAM GUARDRAIL

(Sheet 2 of 4)

STANDARD 630001-12

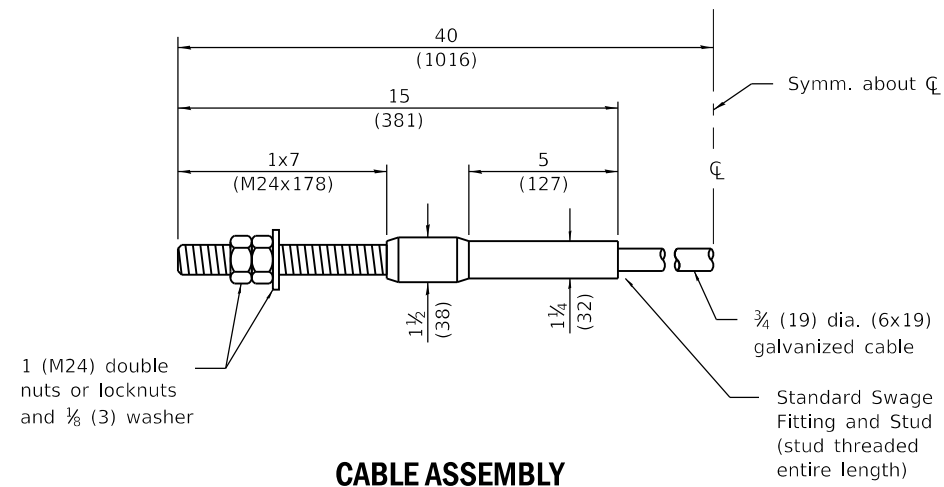

CABLE ASSEMBLY

(42,800 lbs. (190 kN) min. breaking strength)
Tighten to taut tension.

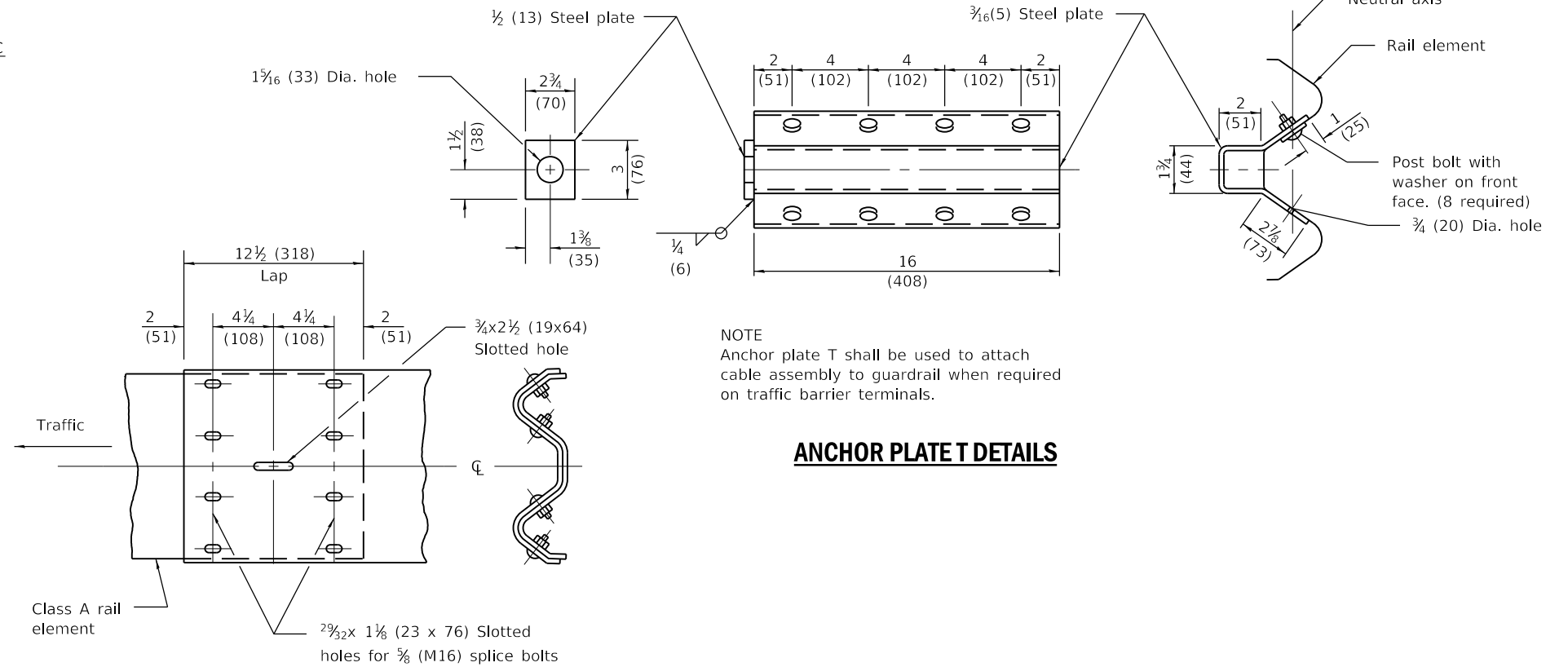

ANCHOR PLATE T DETAILS

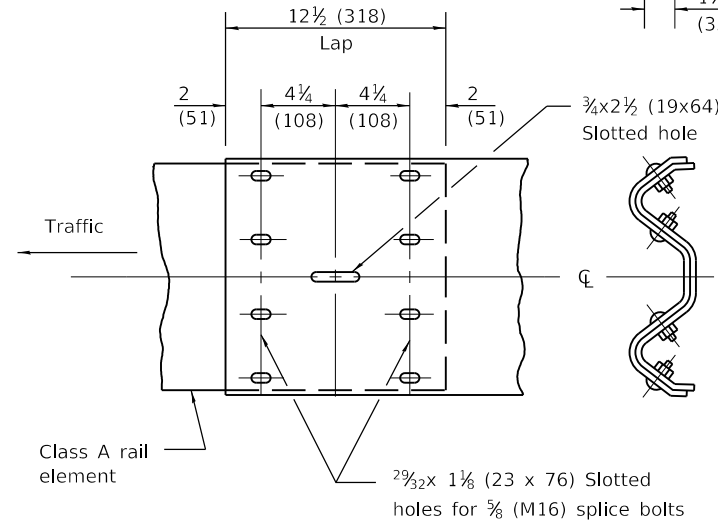

RAIL ELEMENT SPLICE

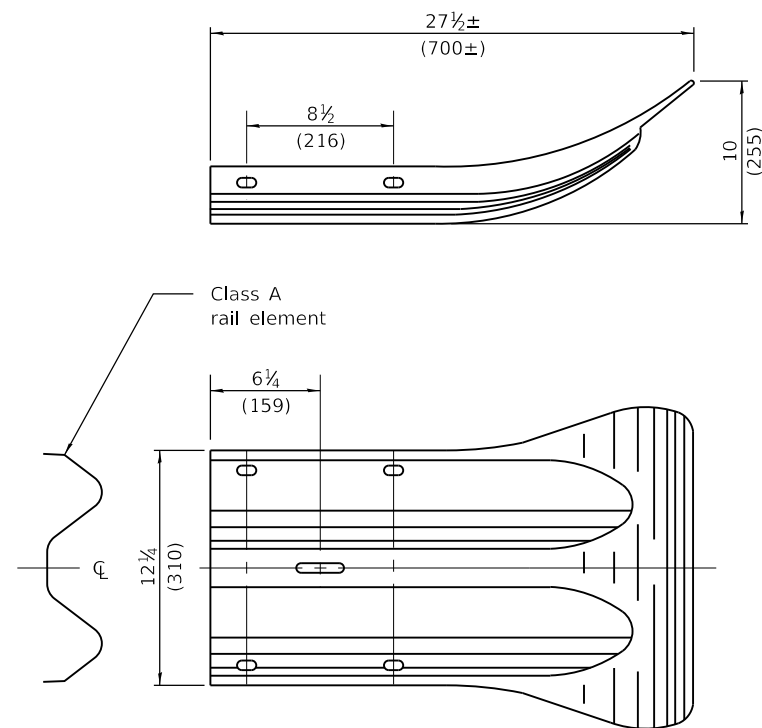

END SECTION

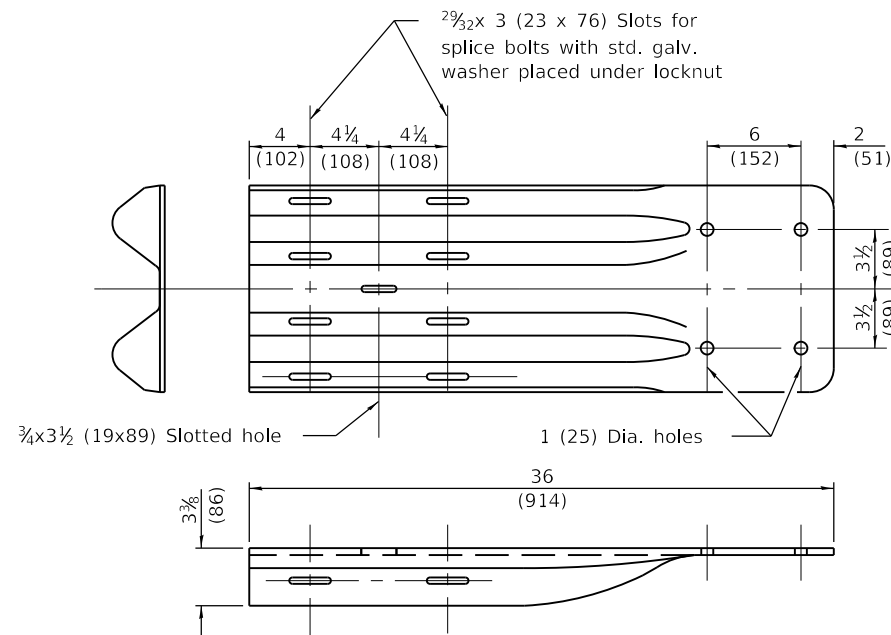

NOTE
When end shoe is attached to a bridge parapet which has an expansion joint, the bolts shall be provided with a locknut or double nut and shall be tightened only to a point that will allow guardrail movement.

The standard end shoe shall be attached to the concrete with pre-drilled or self-drilling anchor bolts. The anchor cone shall be set flush with the surface of the concrete.

Externally threaded studs protruding from the surface of the concrete will not be permitted.

END SHOE

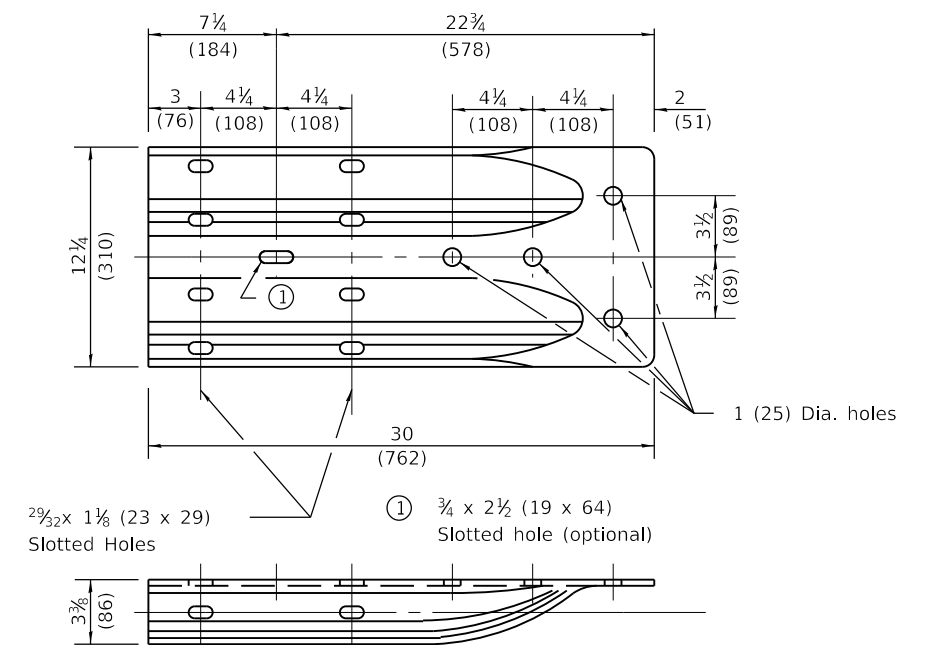

ALTERNATE END SHOE

Illinois Department of Transportation

APPROVED January 1, 2018
Michael Beard
ENGINEER OF POLICY AND PROCEDURES

APPROVED January 1, 2018
Marcus M. Beck
ENGINEER OF DESIGN AND ENVIRONMENT

ISSUED 1-1-97

**STEEL PLATE BEAM
GUARDRAIL**

(Sheet 3 of 4)

STANDARD 630001-12

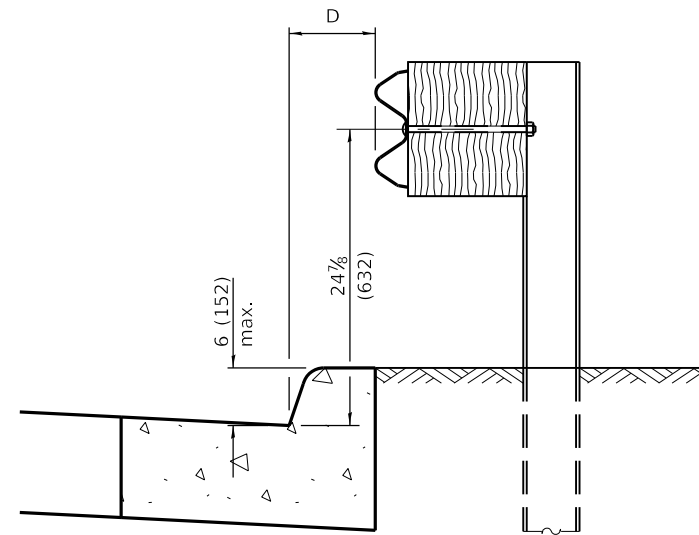

$0 \leq D < 6 (150 \text{ m})$

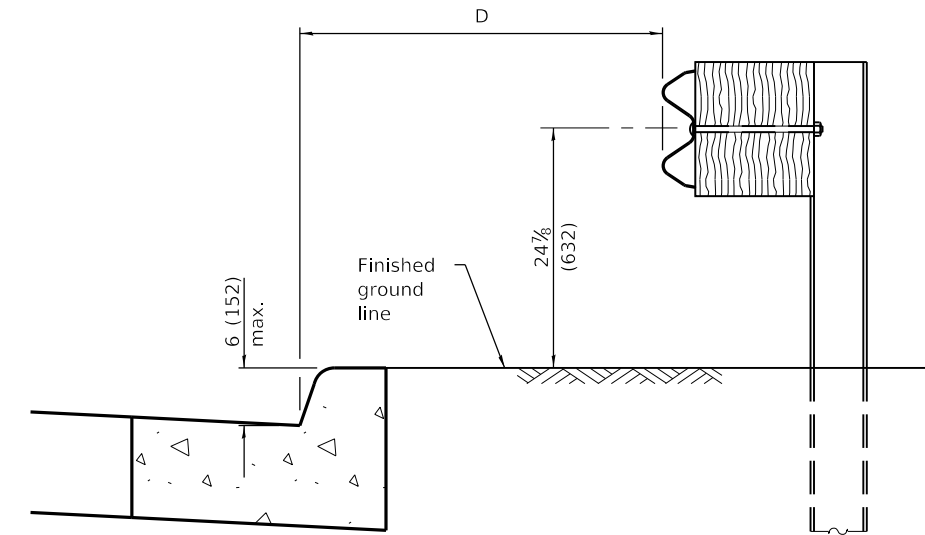

$4'-0'' (1.2 \text{ m}) \leq D \leq 12'-0'' (3.7 \text{ m})$

GUARDRAIL PLACED BEHIND CURB

Note: 'D' shall not exceed 6 (152) for design speeds greater than 45 mph.

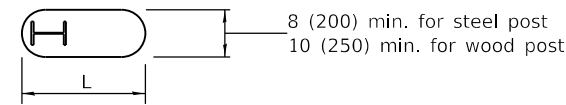

PLAN

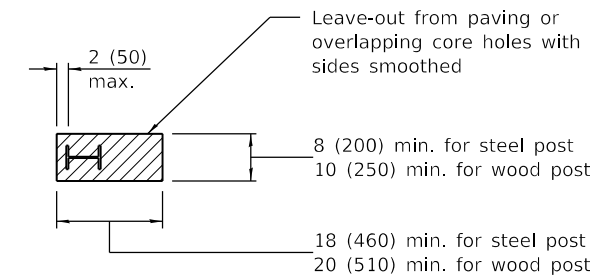

PLAN

V	W	L	
		Steel Post	Wood Post
0 - 6 (0 - 152)	24 (610)	21 (530)	23 (580)
> 6 - 18 (> 152 - 458)	18 (458)	14½ (368)	16½ (419)
> 18 - 31 (> 458 - 787)	12 (305)	8 (203)	10 (250)
> 31 - 40½ (> 787 - 1.02 m)	12 - 0 (305 - 0)	8 (203)	10 (250)

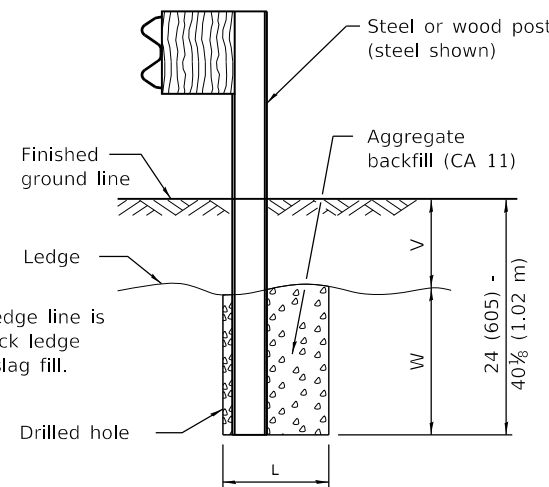

Note: Ledge line is top of rock ledge or hard slag fill.

ELEVATION

FOOTING FOR POST WHEN IMPERVIOUS MATERIAL IS ENCOUNTERED

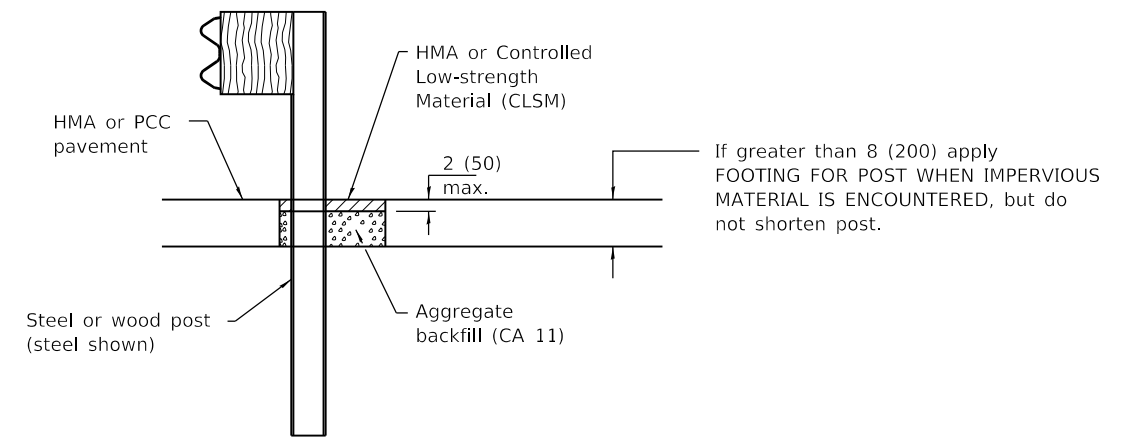

ELEVATION

LEAVE-OUT FOR POST WHEN PAVED MATERIAL IS ENCOUNTERED

STEEL PLATE BEAM GUARDRAIL

(Sheet 4 of 4)

STANDARD 630001-12

Illinois Department of Transportation

APPROVED January 1, 2018
Michael Beard
 ENGINEER OF POLICY AND PROCEDURES

APPROVED January 1, 2018
Marcus M. Beck
 ENGINEER OF DESIGN AND ENVIRONMENT

ISSUED 1-1-97

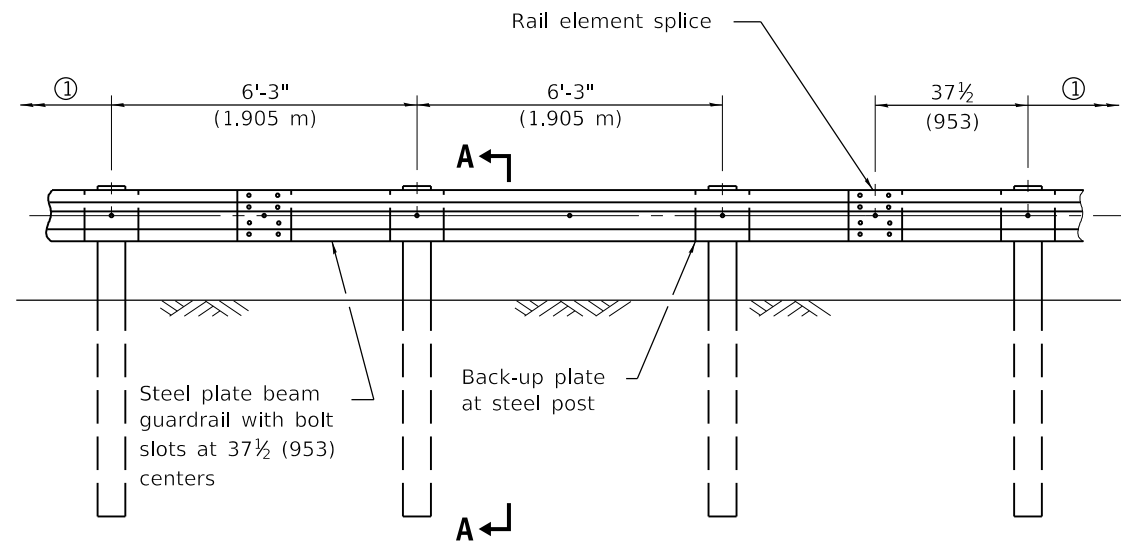

ELEVATION

① When connecting to long-span guardrail over culvert, the next post may be the third (farthest from culvert) CRT wood post (See Standard 630106).

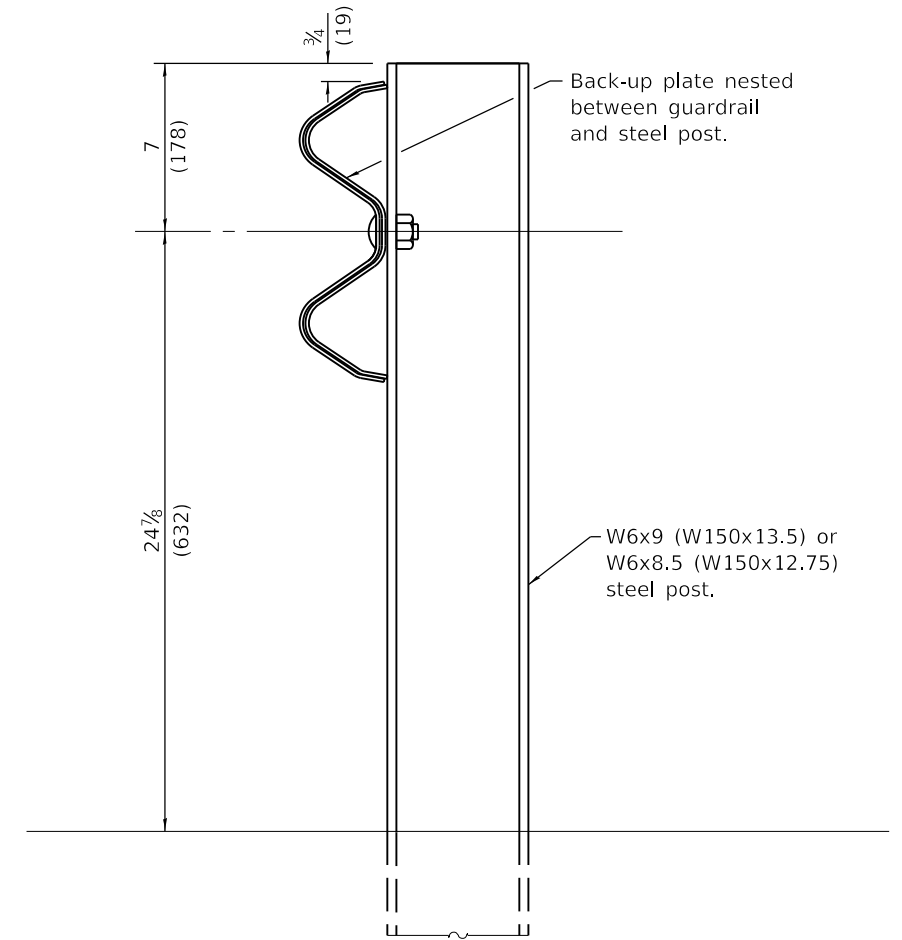

DETAIL AT POST

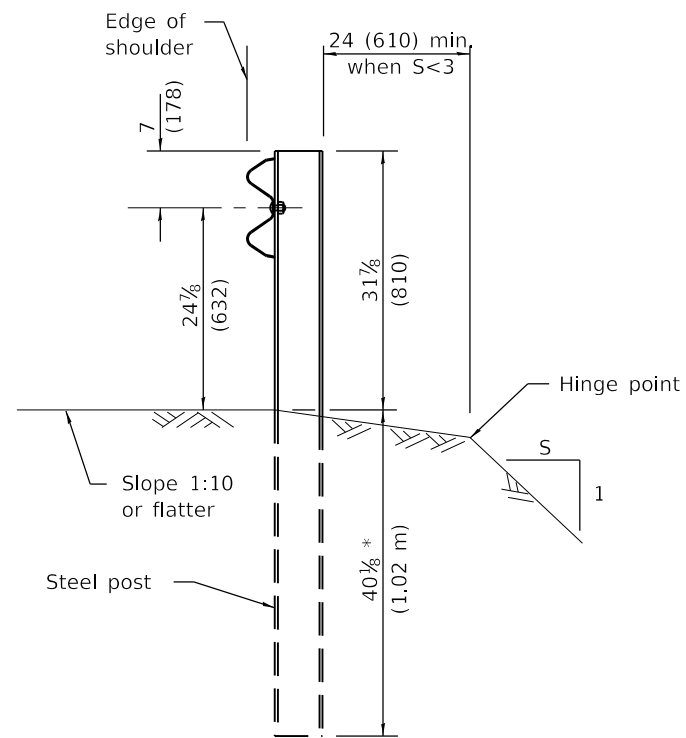

SECTION A-A

* When "S" is less than 3 and the distance from the back of post is less than 24 (610), the post embedment shall be 76 1/8 (1.93 m) and the minimum top of rail height shall be 31 (787).

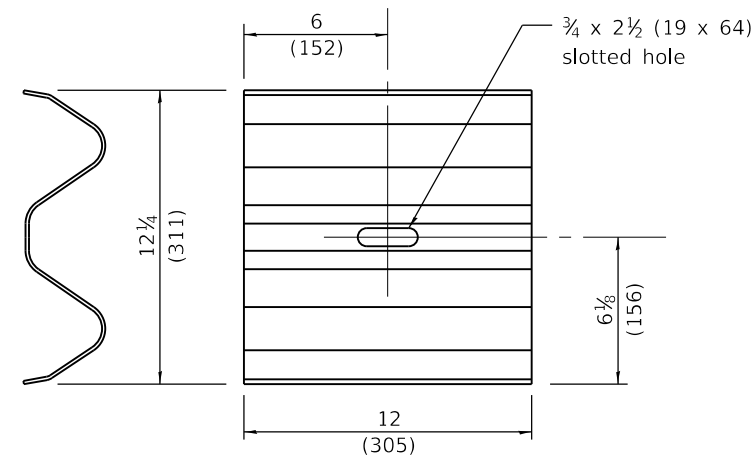

BACK-UP PLATE

GENERAL NOTES

All slope ratios are expressed as units of vertical displacement to units of horizontal displacement (V:H).

For details of guardrail elements not shown, see Standard 630001.

All dimensions are in inches (millimeters) unless otherwise shown.

DATE	REVISIONS
1-1-17	New standard.

NON-BLOCKED STEEL PLATE BEAM GUARDRAIL

(Sheet 1 of 2)

STANDARD 630006

Illinois Department of Transportation

PASSED January 1, 2017
Michael Beard
 ENGINEER OF POLICY AND PROCEDURES

APPROVED January 1, 2017
Maureen M. Beck
 ENGINEER OF DESIGN AND ENVIRONMENT

ISSUED 1-1-17

V	W	L
0 - 6 (0 - 152)	24 (610)	21 (530)
> 6 - 18 (> 152 - 458)	18 (458)	14½ (368)
> 18 - 31 (> 458 - 787)	12 (305)	8 (203)
> 31 - 40½ (> 787 - 1.02 m)	12 - 0 (305 - 0)	8 (203)

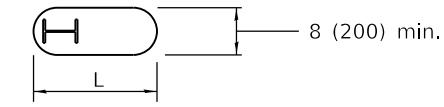

PLAN

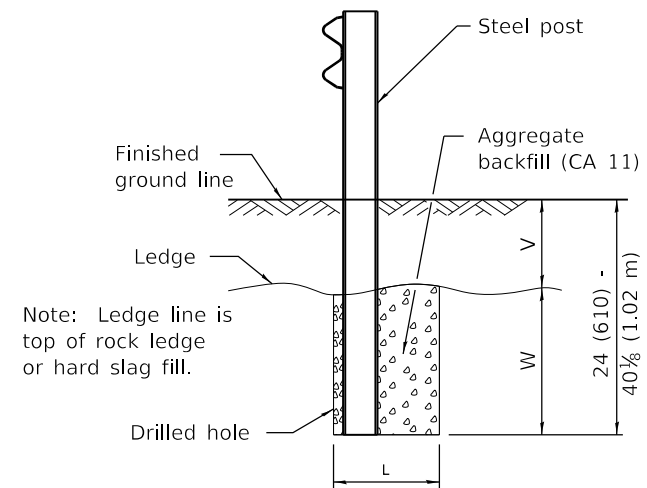

ELEVATION

FOOTING FOR POST WHEN IMPERVIOUS MATERIAL IS ENCOUNTERED

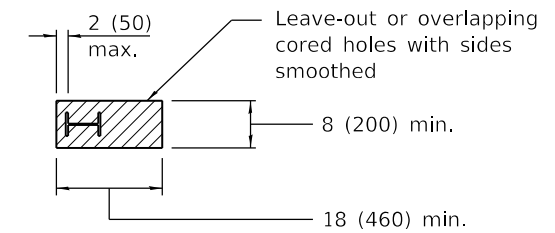

PLAN

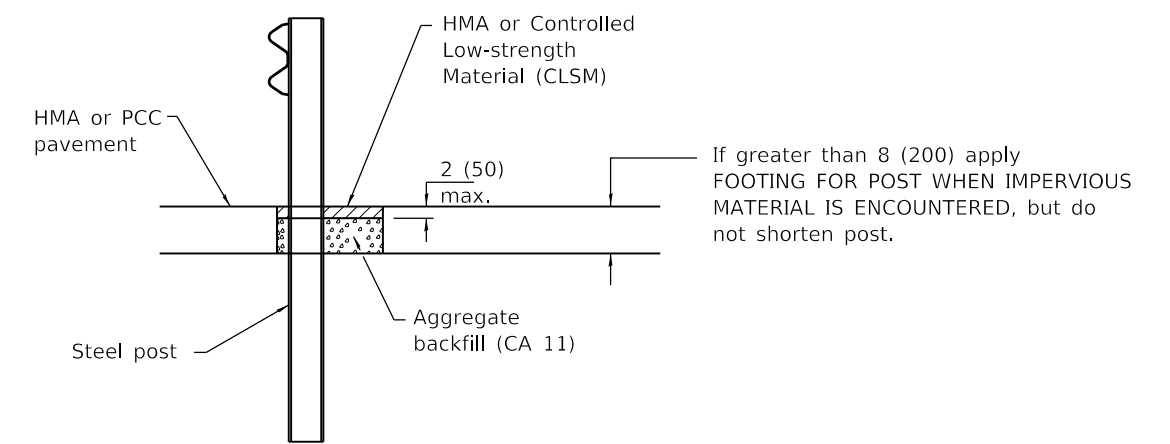

ELEVATION

LEAVE-OUT FOR POST WHEN PAVED MATERIAL IS ENCOUNTERED

Illinois Department of Transportation

PASSED January 1, 2017
Michael Beard
 ENGINEER OF POLICY AND PROCEDURES

APPROVED January 1, 2017
Marcus M. Adams
 ENGINEER OF DESIGN AND ENVIRONMENT

ISSUED 1-1-17

**NON-BLOCKED STEEL
 PLATE BEAM GUARDRAIL**

(Sheet 2 of 2)

STANDARD 630006

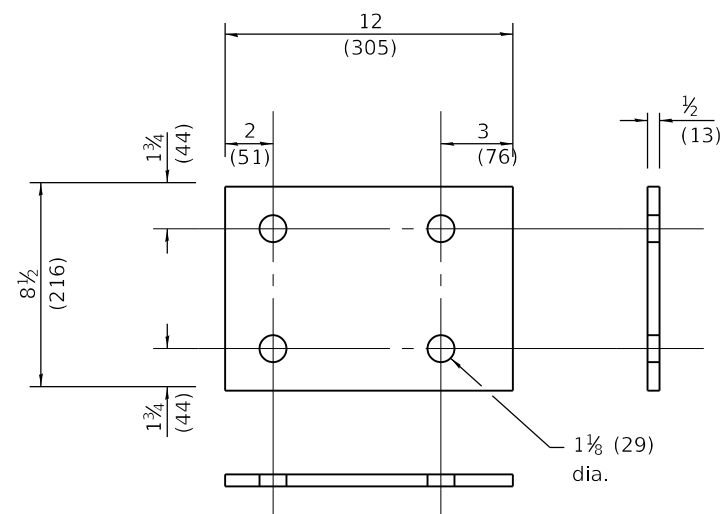

MOUNTING PLATE

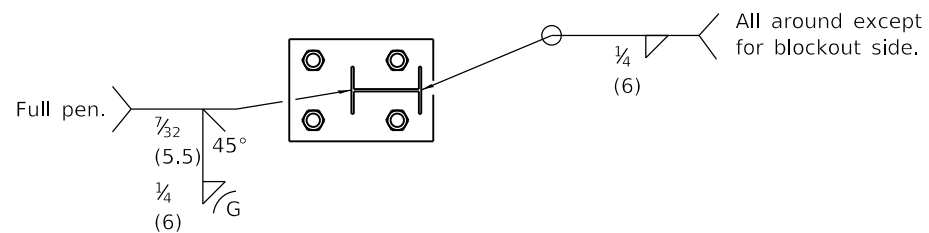

SECTION A-A

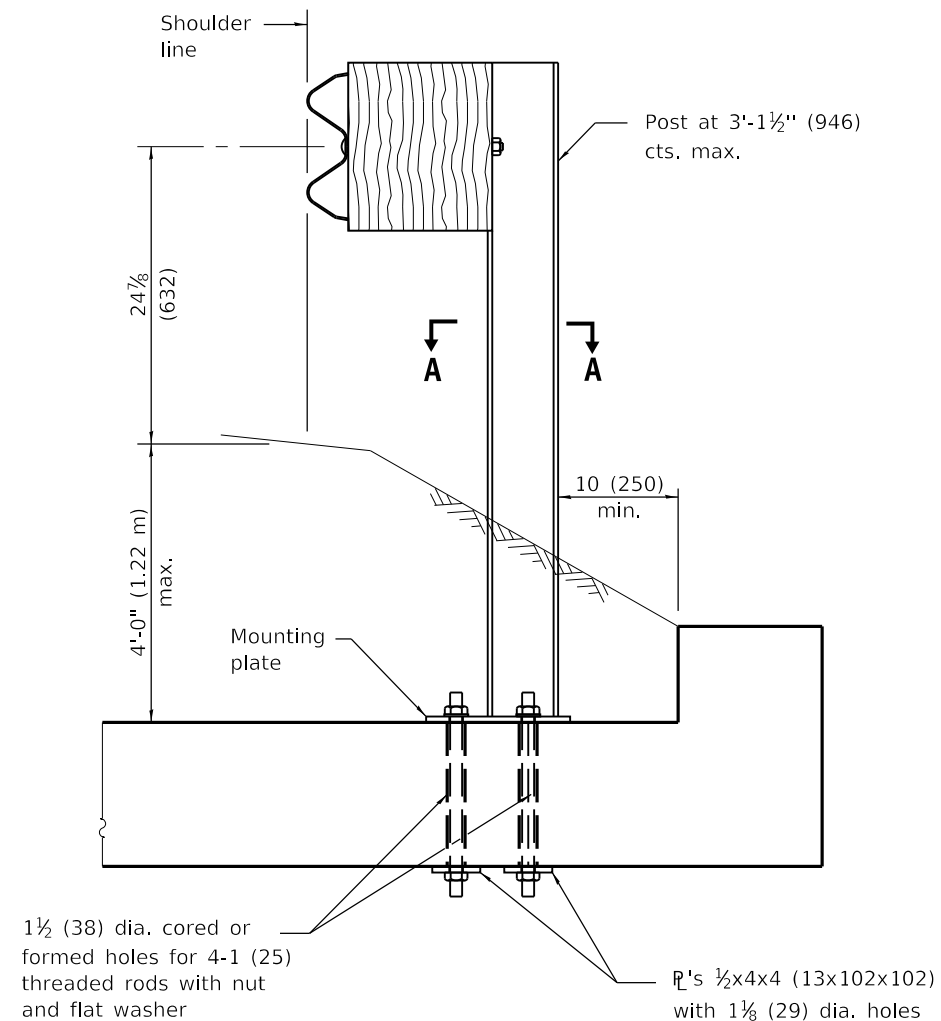

CROSS SECTION

GENERAL NOTES

For details of guardrail elements not shown, see Standard 630001.

All threaded rods shall be installed with heavy hex nuts and standard washers.

All dimensions are in inches (millimeters) unless otherwise shown.

DATE	REVISIONS
1-1-17	Omitted all cases but MNT.
	ON SLAB. Renamed standard.
	Added mounting plate detail.
1-1-11	Revised weld detail
	for Case IV.

**STRONG POST
GUARDRAIL ATTACHED
TO CULVERT**

STANDARD 630101-10

Illinois Department of Transportation

PASSED January 1, 2017
Michael Beard
 ENGINEER OF POLICY AND PROCEDURES

APPROVED January 1, 2017
Marcus M. Beck
 ENGINEER OF DESIGN AND ENVIRONMENT

ISSUED 1-1-97

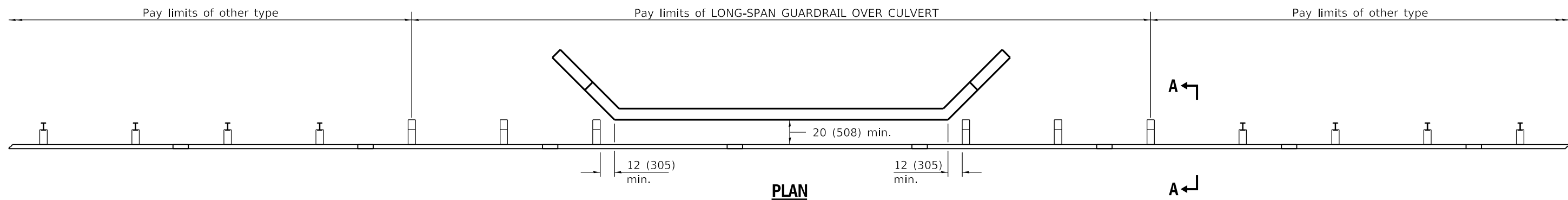

PLAN

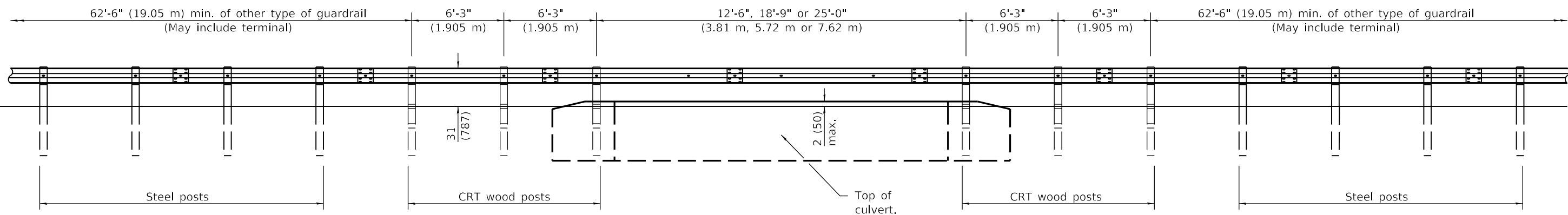

ELEVATION

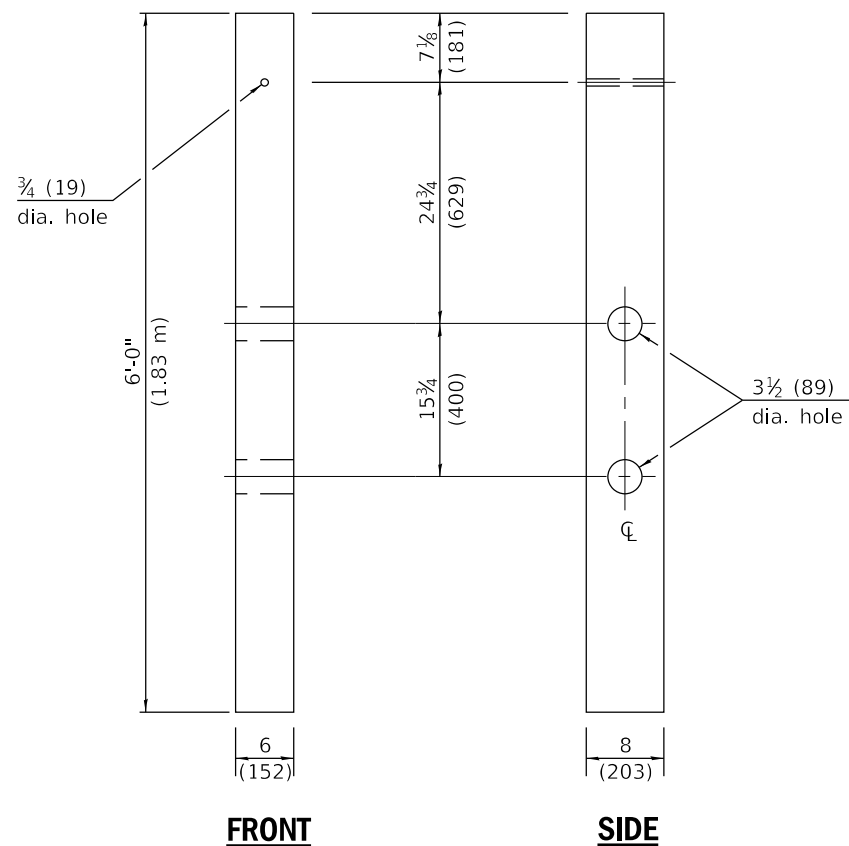

FRONT

SIDE

CRT WOOD POST

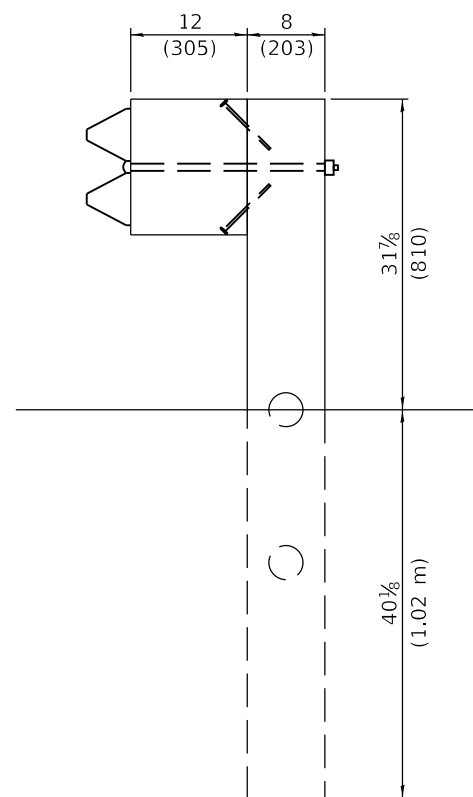

SECTION A-A

GENERAL NOTES

See Standard 630001 for details of guardrail not shown.

Blockouts shown at steel posts shall be omitted when NON-BLOCKED STEEL PLATE BEAM GUARDRAIL is specified. See Standard 630006 for details not shown.

All dimensions are in inches (millimeters) unless otherwise shown.

DATE	REVISIONS
1-1-17	Revised general notes for non-blocked guardrail option.
	Revised pay limits.
1-1-13	Added min. dim. from guardrail to headwall. Added dim. to section A-A.

LONG-SPAN GUARDRAIL OVER CULVERT

STANDARD 630106-02

Illinois Department of Transportation

PASSED January 1, 2017
Michael Beard
 ENGINEER OF POLICY AND PROCEDURES

APPROVED January 1, 2017
Maureen M. Beck
 ENGINEER OF DESIGN AND ENVIRONMENT

ISSUED 1-1-17

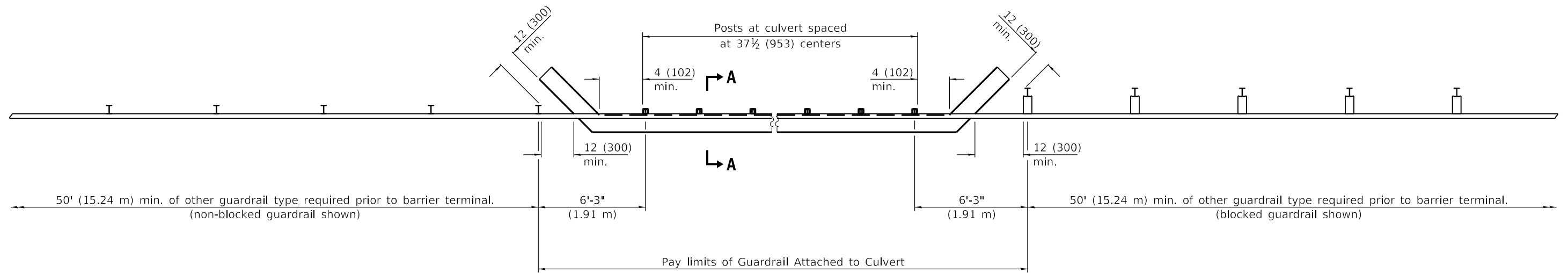

PLAN

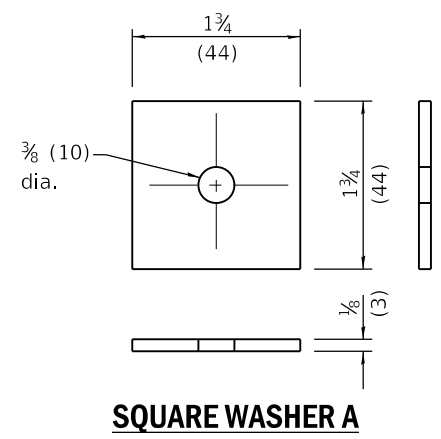

SQUARE WASHER A

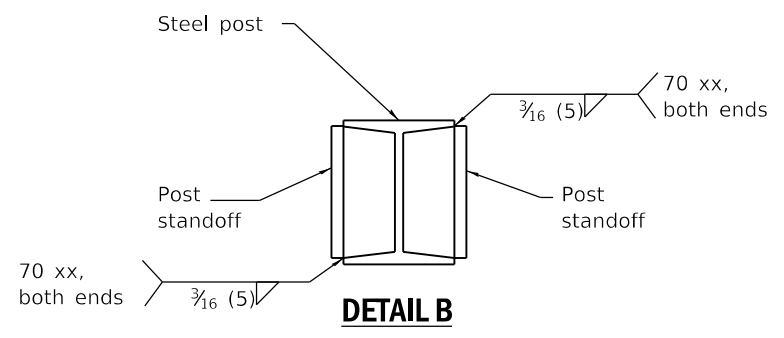

DETAIL B

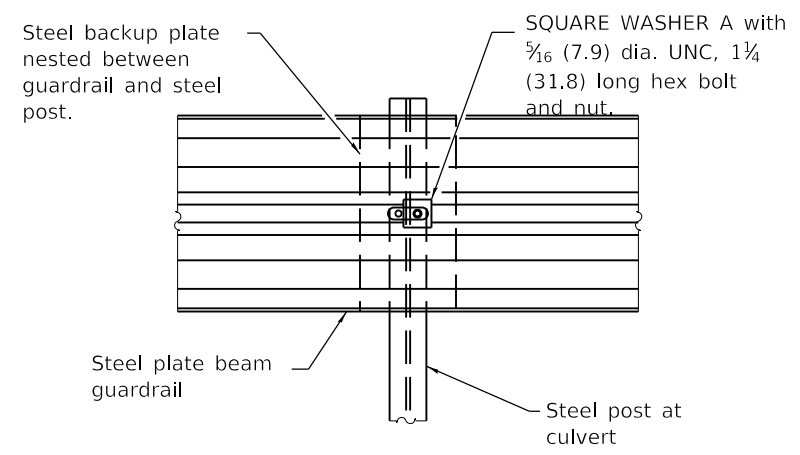

DETAIL A

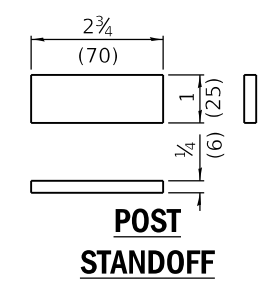

POST STANDOFF

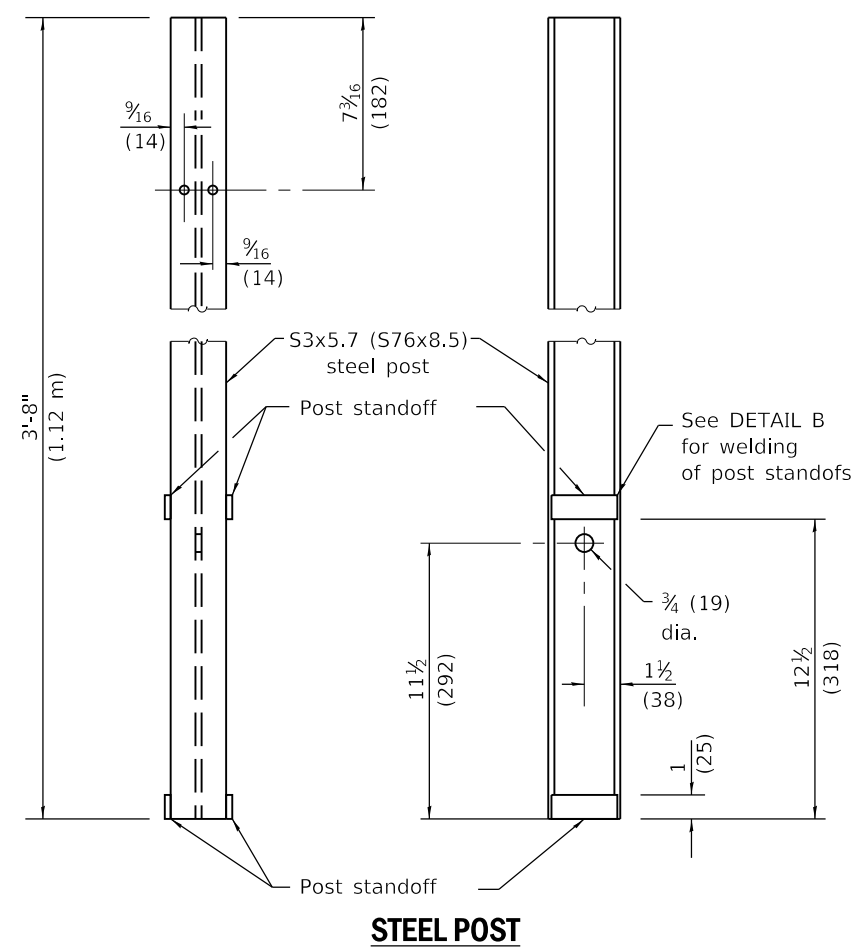

STEEL POST

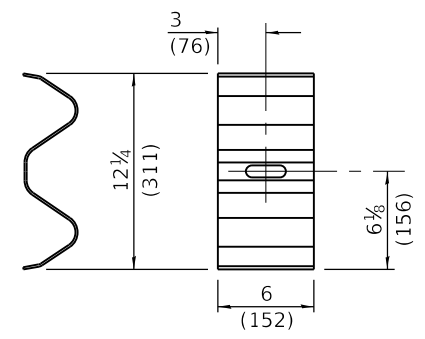

BACKUP PLATE

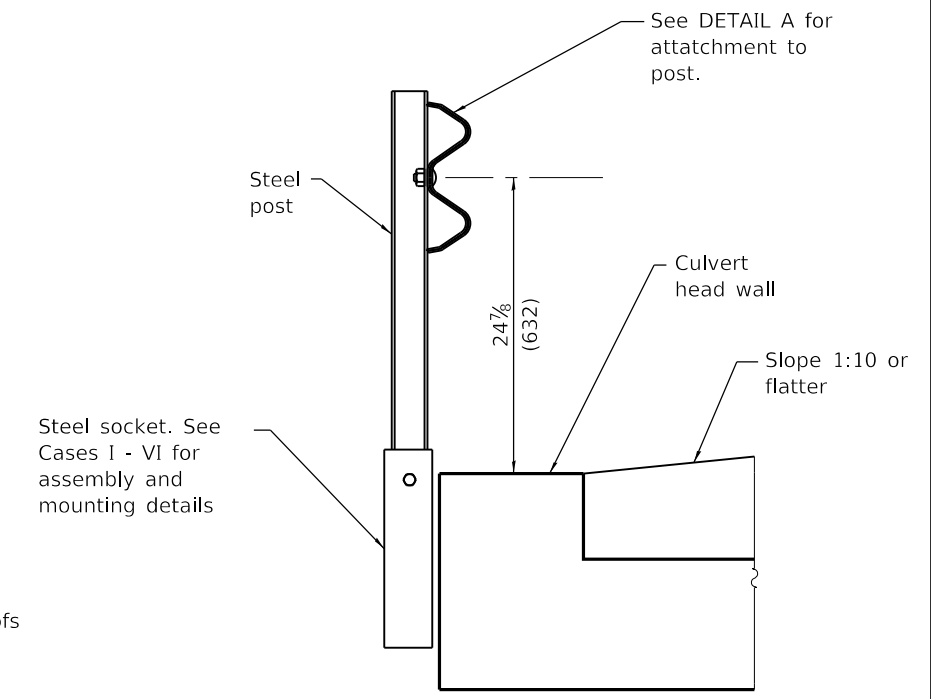

SECTION A-A

GENERAL NOTES

- See Standard 630001 for details of guardrail not shown.
- See Standard 630006 for details of non-blocked guardrail not shown.
- All threaded rods and bolts shall be installed with heavy hex nuts and standard washers unless noted otherwise.
- All dimensions are in inches (millimeters) unless otherwise shown.

Illinois Department of Transportation

PASSED January 1, 2020
Michael Bond
 ENGINEER OF POLICY AND PROCEDURES

APPROVED January 1, 2020
J. Sch. Ege
 ENGINEER OF DESIGN AND ENVIRONMENT

ISSUED 1-1-17

DATE	REVISIONS
1-1-20	Revised HHS to HSS in Top View on sheets 2-5.
1-1-17	New Standard.

WEAK POST GUARDRAIL ATTACHED TO CULVERT

(Sheet 1 of 6)

STANDARD 630111-01

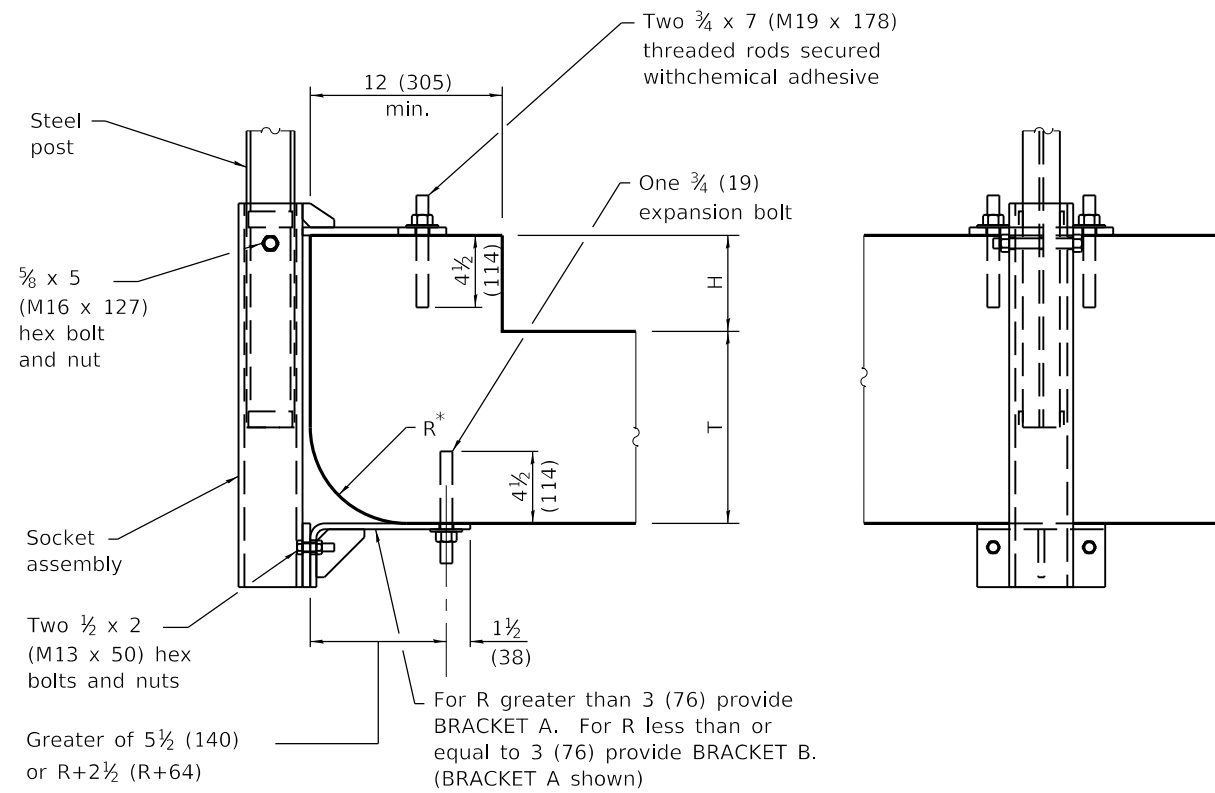

CROSS SECTION

ELEVATION

CASE I, (H+T-R) < 18 (457), TOP MOUNT

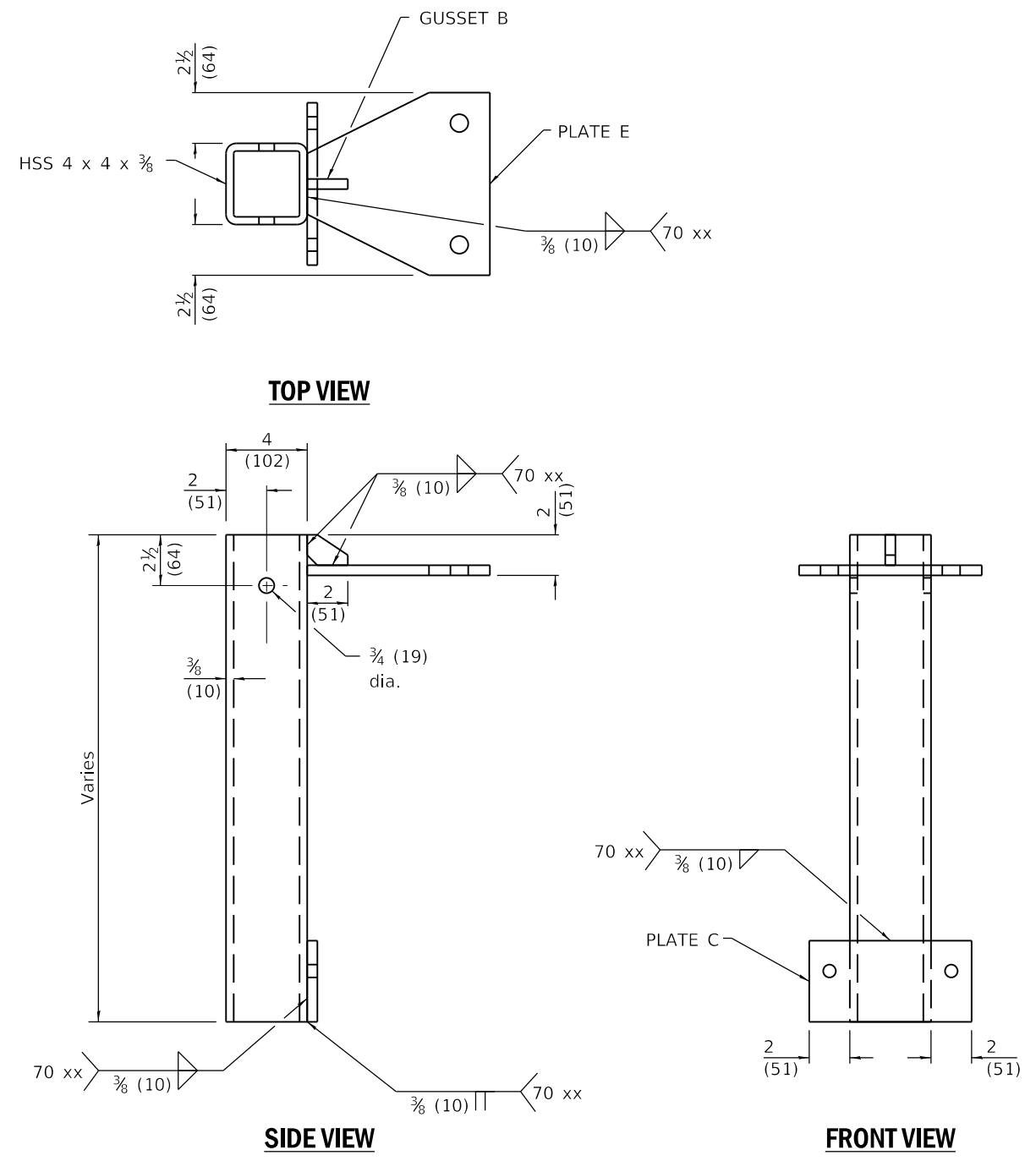

SOCKET ASSEMBLY FOR CASE I

Illinois Department of Transportation

PASSED January 1, 2020

Michael Bond
ENGINEER OF POLICY AND PROCEDURES

APPROVED January 1, 2020

J. S. Egan
ENGINEER OF DESIGN AND ENVIRONMENT

ISSUED 1-1-17

WEAK POST GUARDRAIL ATTACHED TO CULVERT

(Sheet 2 of 6)

STANDARD 630111-01

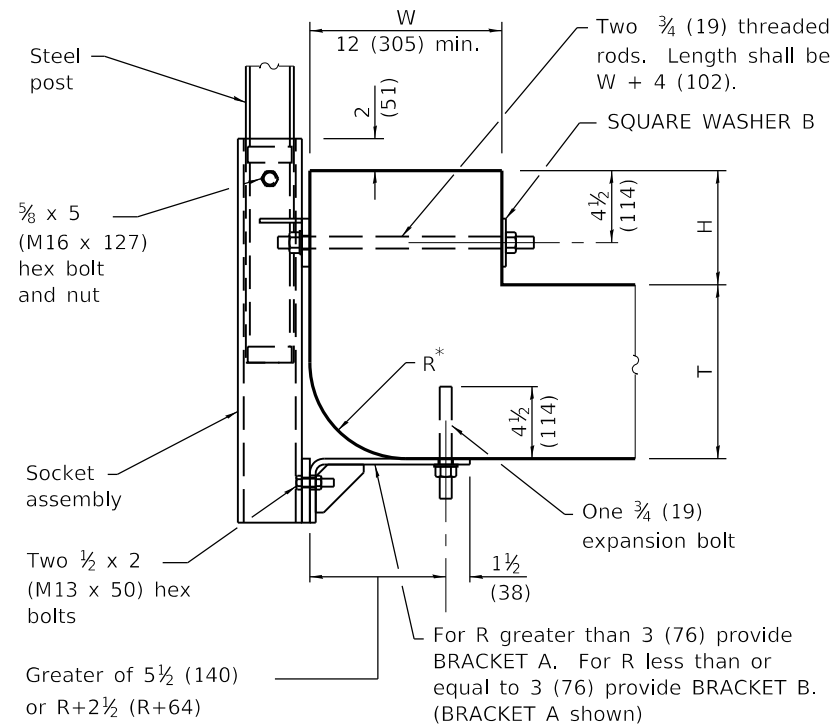

CROSS SECTION

CASE II, (H+T-R) < 18 (457), SIDE-MOUNT THROUGH-BOLT

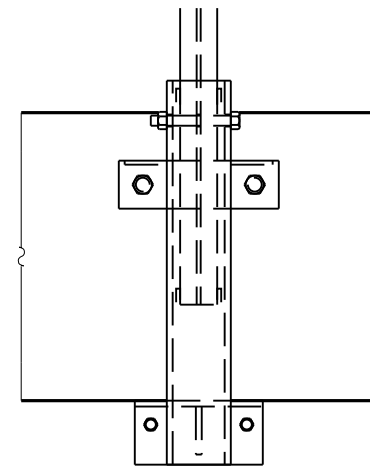

ELEVATION

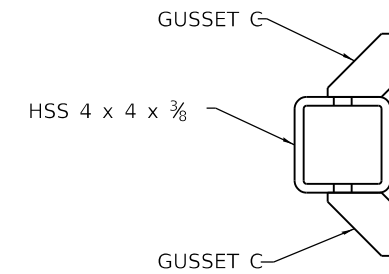

TOP VIEW

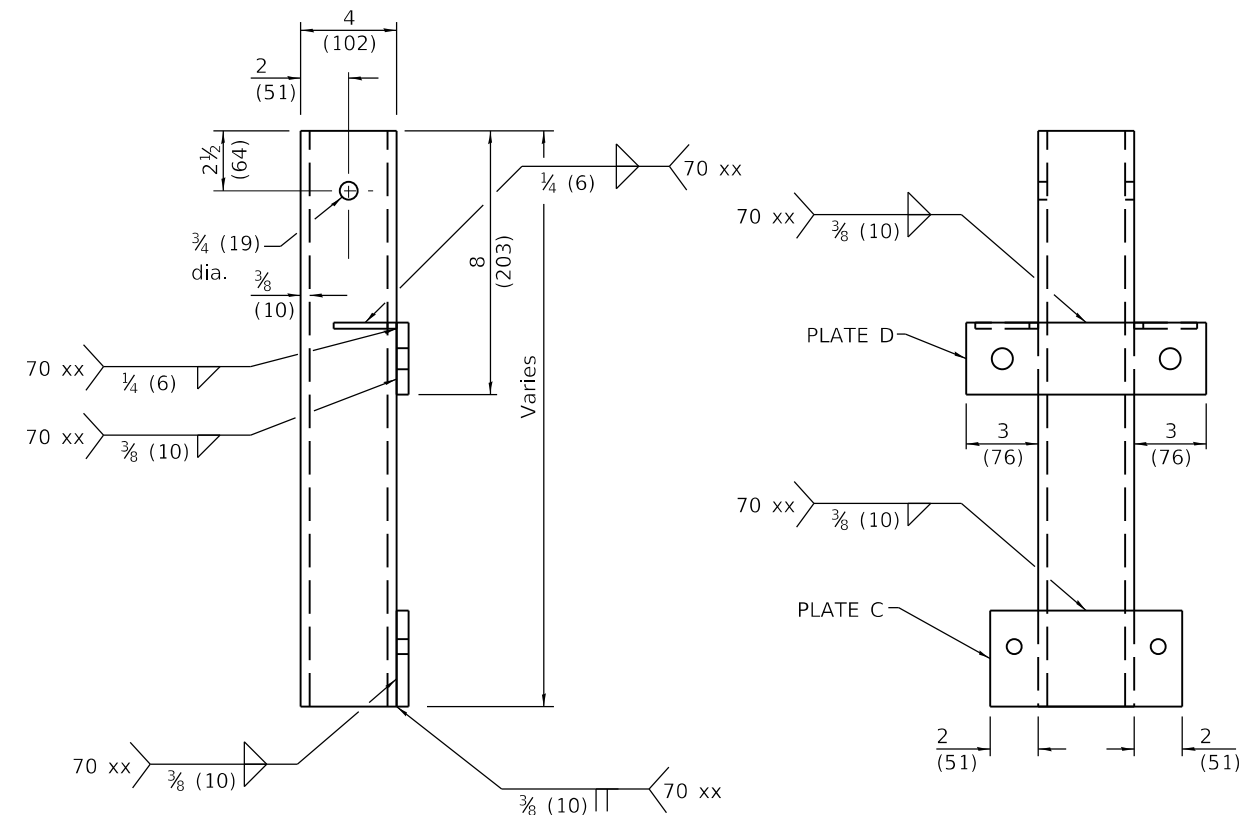

SIDE VIEW

FRONT VIEW

SOCKET ASSEMBLY FOR CASES II & III

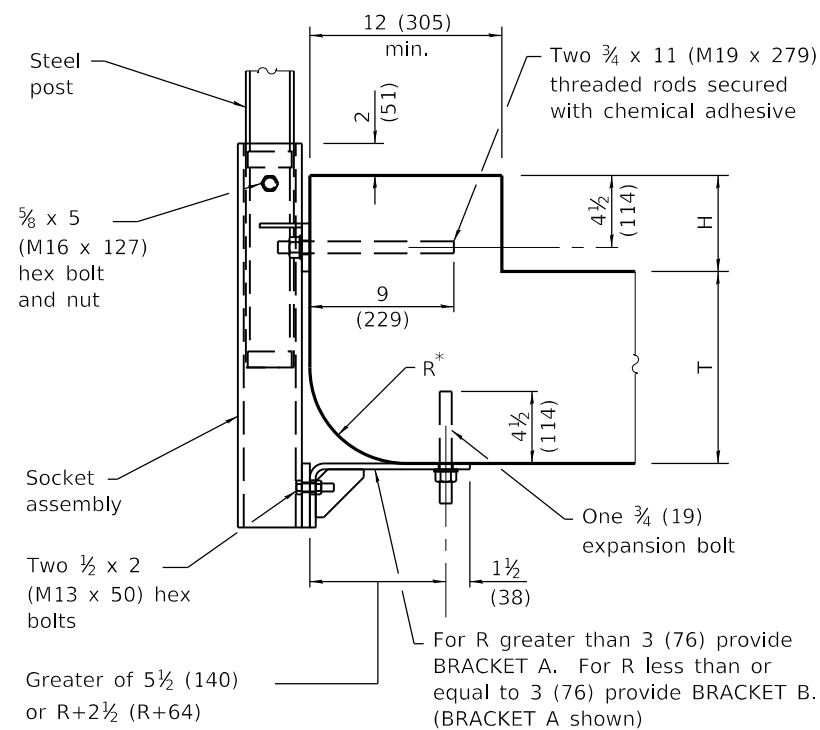

CROSS SECTION

CASE III, (H+T-R) < 18 (457), SIDE-MOUNT ANCHORED

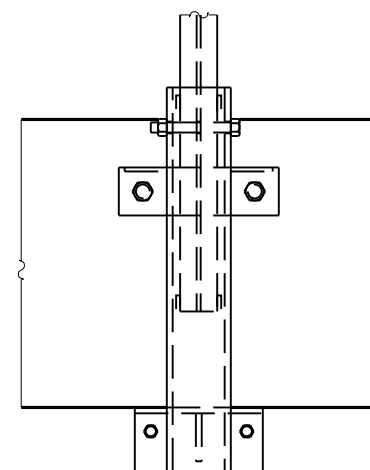

ELEVATION

Illinois Department of Transportation

PASSED January 1, 2020
Michael Bond
 ENGINEER OF POLICY AND PROCEDURES

APPROVED January 1, 2020
J. S. Ch. E. G.
 ENGINEER OF DESIGN AND ENVIRONMENT

ISSUED 1-1-17

WEAK POST GUARDRAIL ATTACHED TO CULVERT

(Sheet 3 of 6)

STANDARD 630111-01

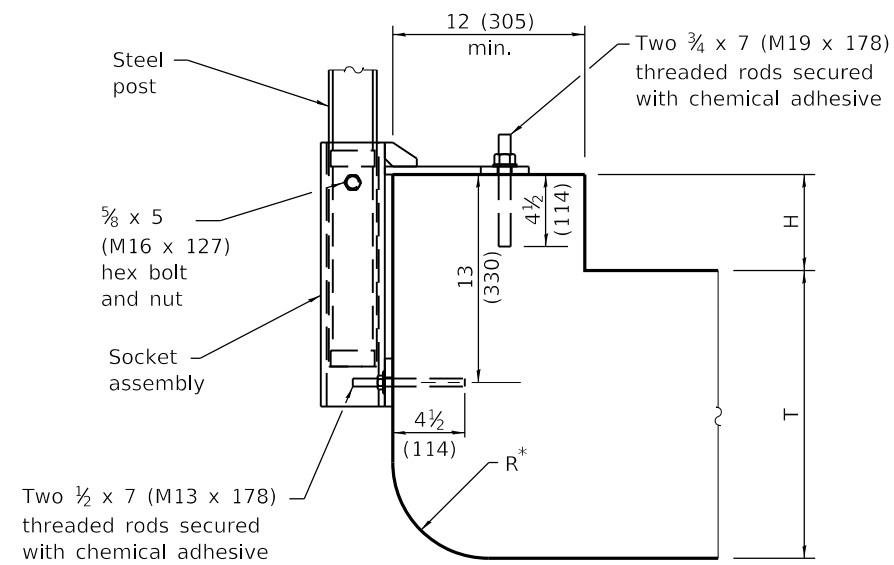

* R varies between 0 to 6 (152)

CROSS SECTION

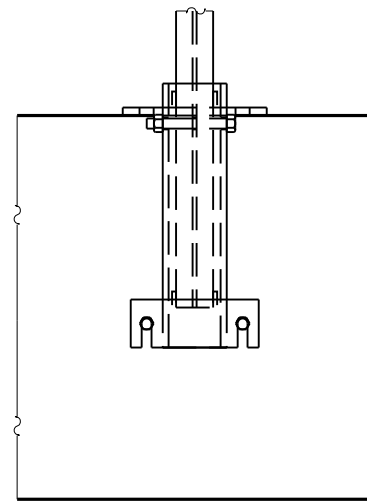

ELEVATION

CASE IV, (H+T-R) ≥ 18 (457), TOP MOUNT

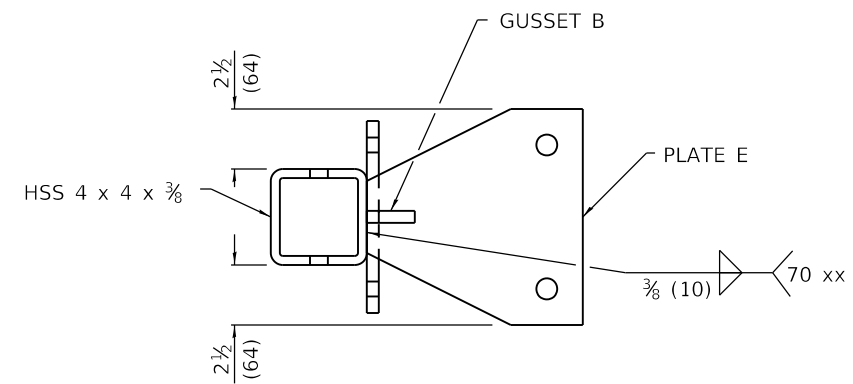

TOP VIEW

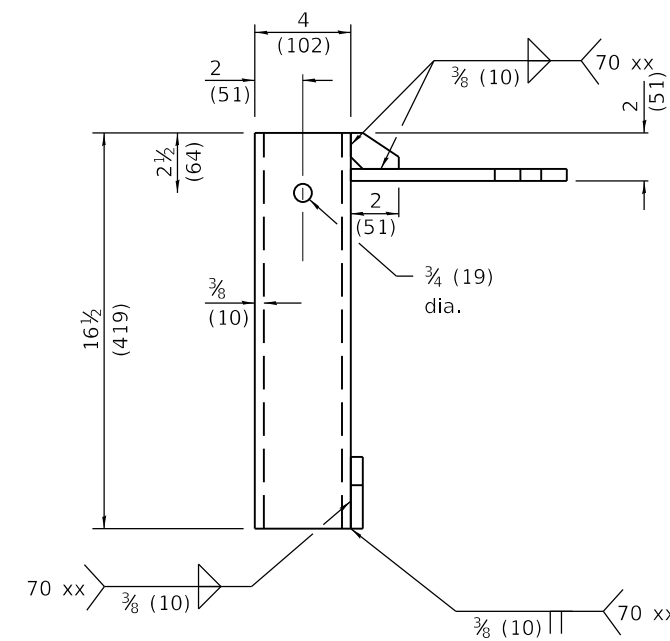

SIDE VIEW

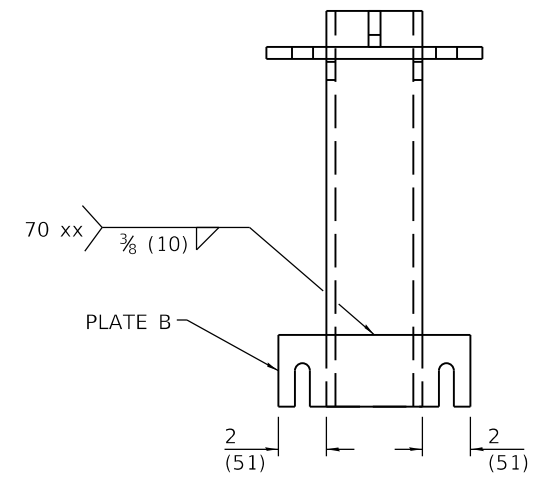

FRONT VIEW

**SOCKET ASSEMBLY
FOR CASE IV**

Illinois Department of Transportation

PASSED January 1, 2020
Michael Bond
 ENGINEER OF POLICY AND PROCEDURES

APPROVED January 1, 2020
J. E. Egan
 ENGINEER OF DESIGN AND ENVIRONMENT

ISSUED 1-1-17

**WEAK POST GUARDRAIL
ATTACHED TO CULVERT**

(Sheet 4 of 6)

STANDARD 630111-01

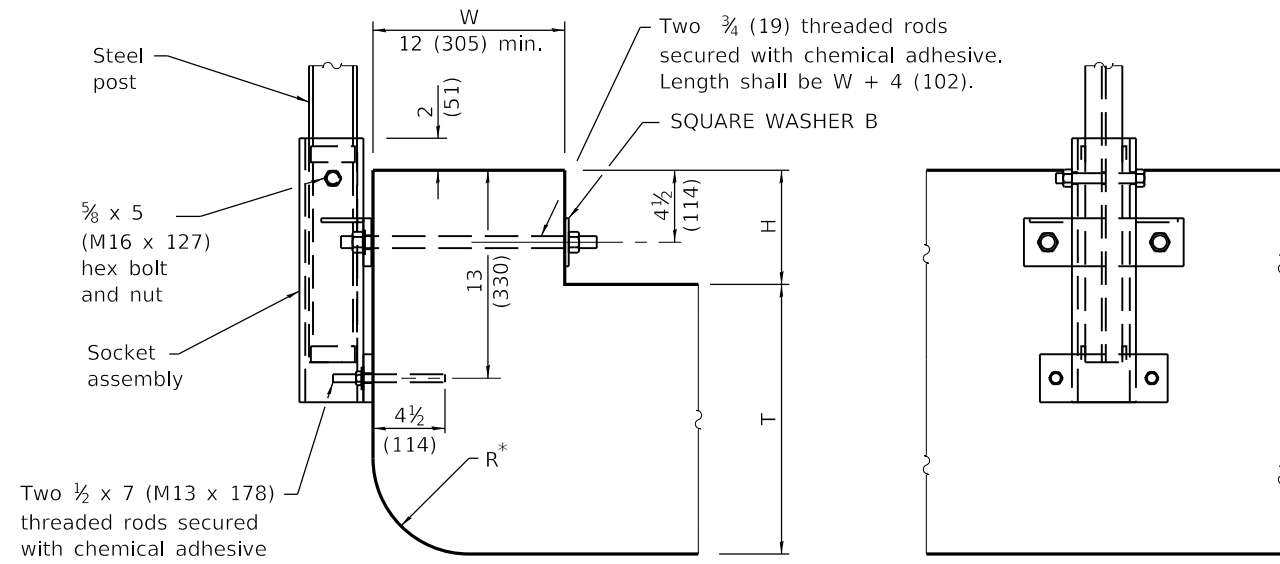

* R varies between 0 to 6 (152)

CROSS SECTION **ELEVATION**
CASE V, (H+T-R) ≥ 18 (457), SIDE-MOUNT, THROUGH-BOLT

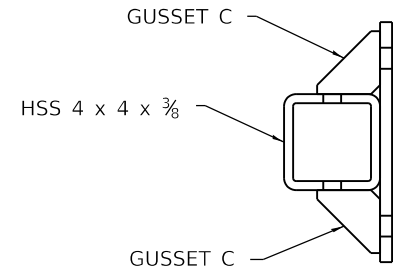

TOP VIEW

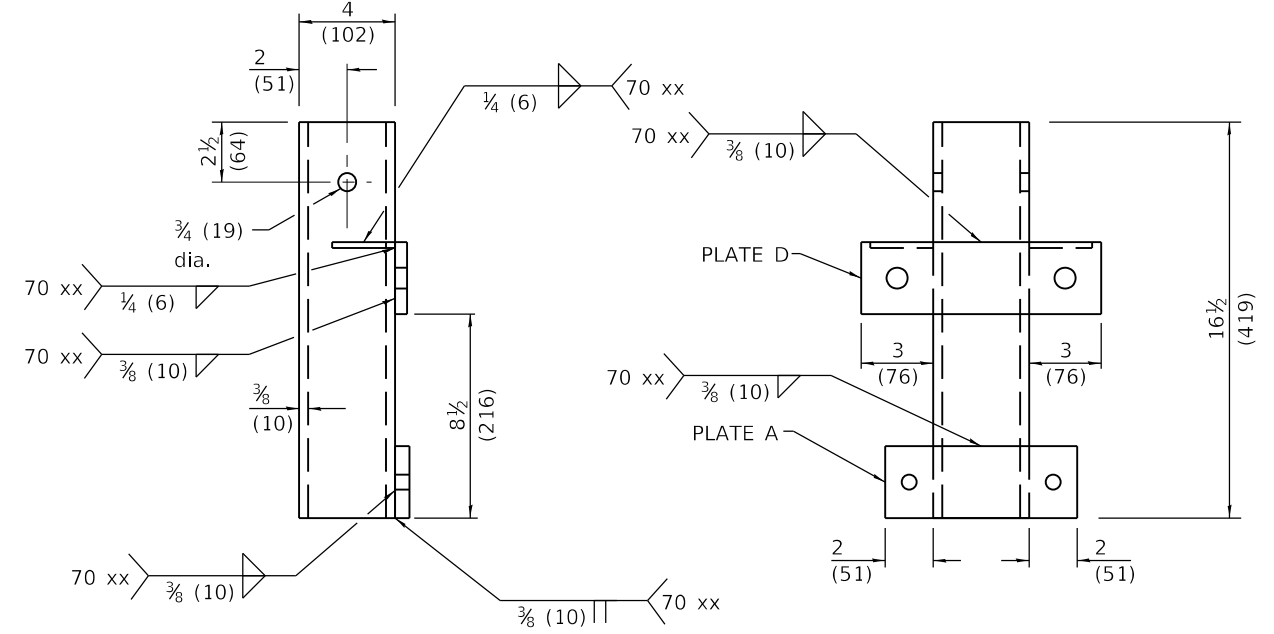

SIDE VIEW

FRONT VIEW

SOCKET ASSEMBLY FOR CASES V & VI

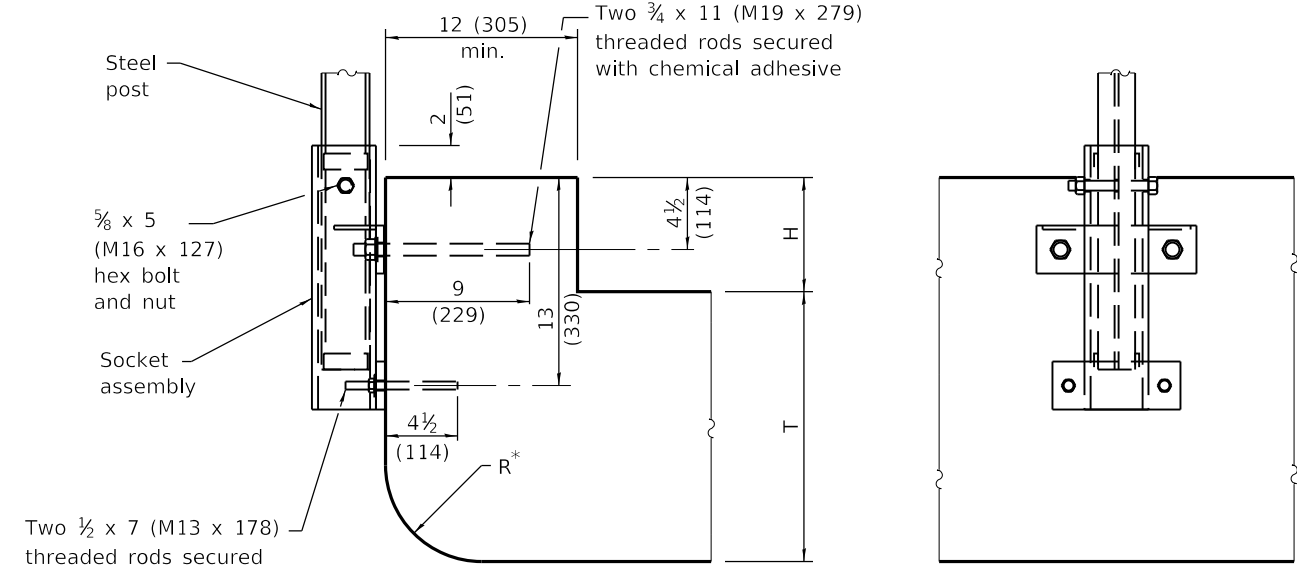

* R varies between 0 to 6 (152)

CROSS SECTION **ELEVATION**
CASE VI, (H+T-R) ≥ 18 (457), SIDE-MOUNT ANCHORED

Illinois Department of Transportation

PASSED January 1, 2020
Michael Bond
 ENGINEER OF POLICY AND PROCEDURES

APPROVED January 1, 2020
J. C. Egan
 ENGINEER OF DESIGN AND ENVIRONMENT

ISSUED 1-1-17

WEAK POST GUARDRAIL ATTACHED TO CULVERT
 (Sheet 5 of 6)

STANDARD 630111-01

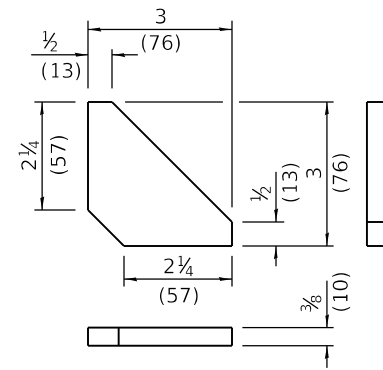

GUSSET A

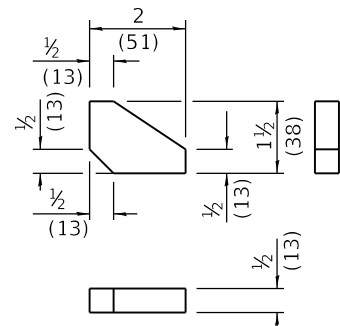

GUSSET B

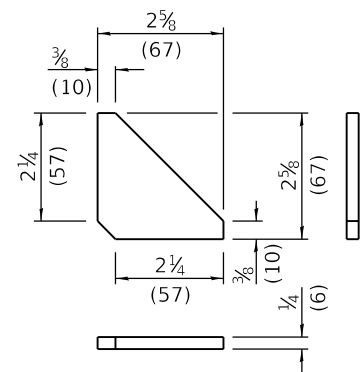

GUSSET C

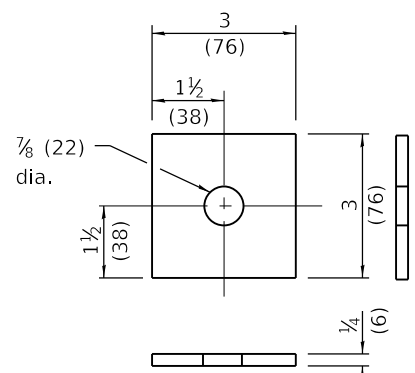

SQUARE WASHER B

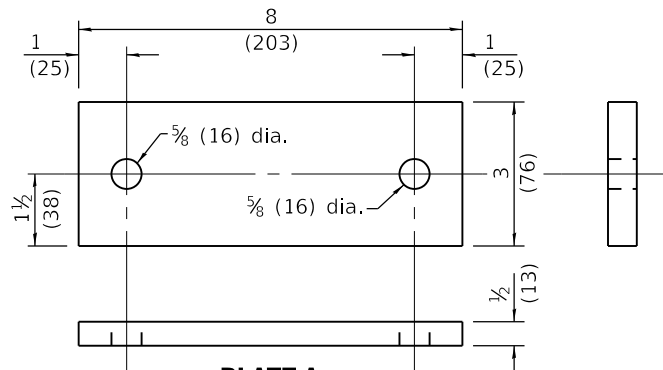

PLATE A

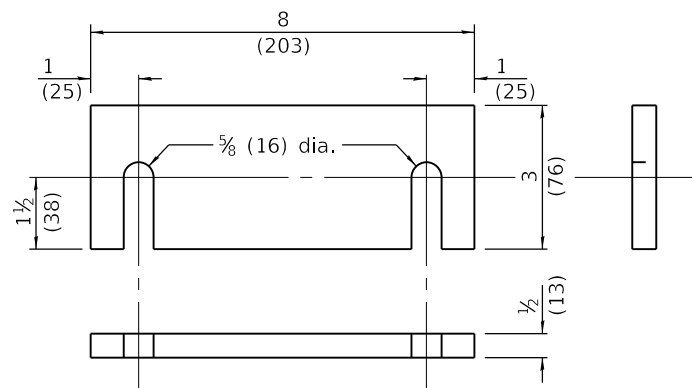

PLATE B

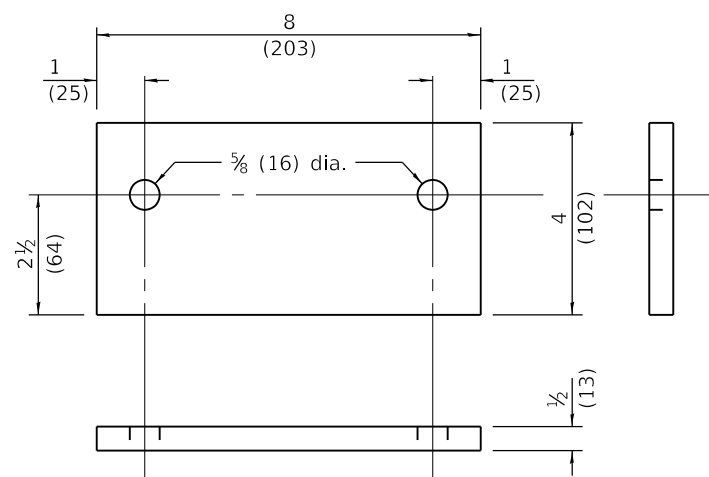

PLATE C

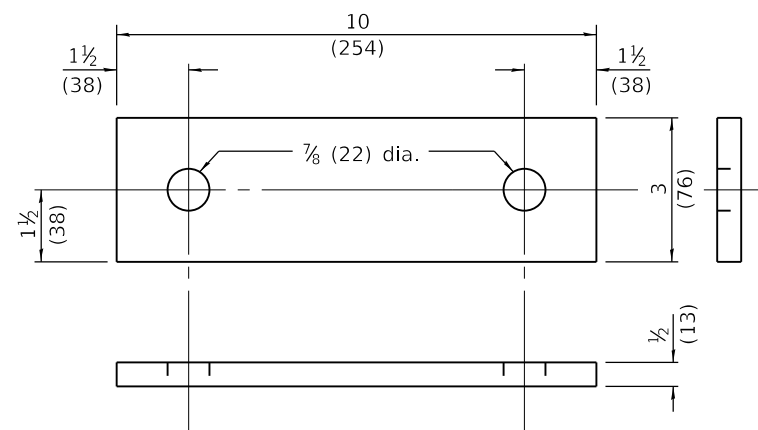
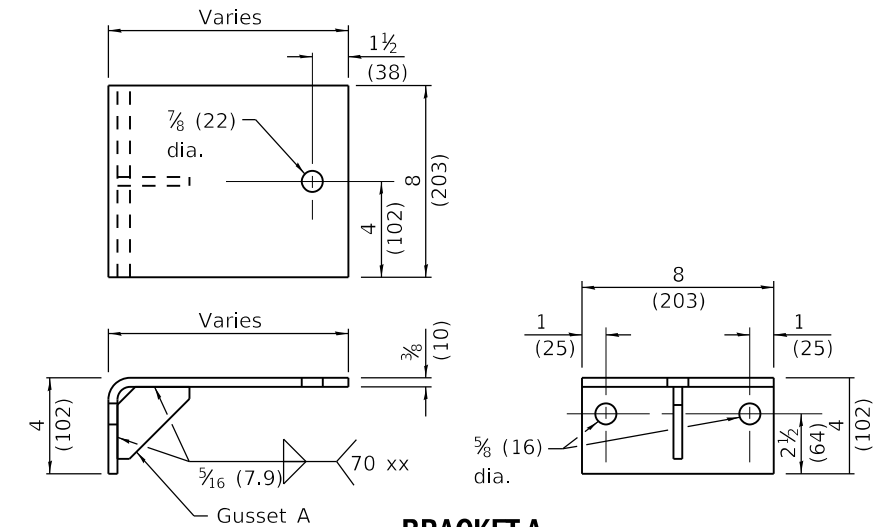
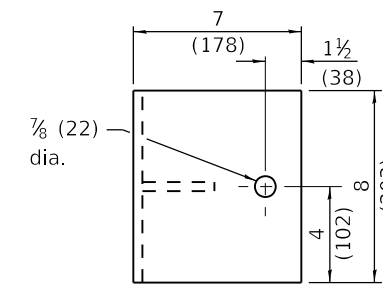

PLATE D



BRACKET A



BRACKET B

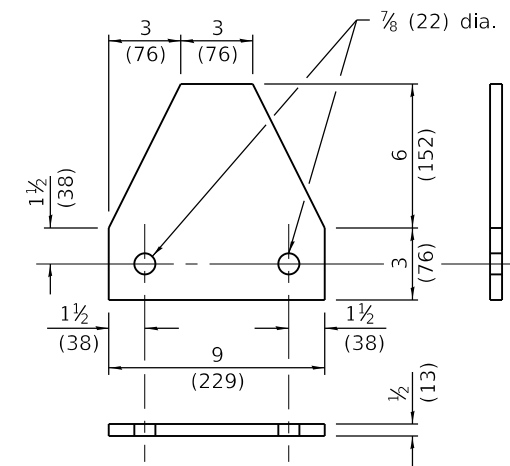
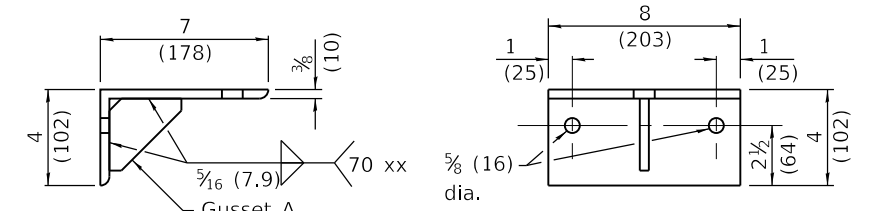

PLATE E

**WEAK POST GUARDRAIL
ATTACHED TO CULVERT**

(Sheet 6 of 6)

STANDARD 630111-01

Illinois Department of Transportation

PASSED January 1, 2020
Michael Bond
 ENGINEER OF POLICY AND PROCEDURES

APPROVED January 1, 2020
J. S. Ch. E. G.
 ENGINEER OF DESIGN AND ENVIRONMENT

ISSUES 4-1-1 03/05/11

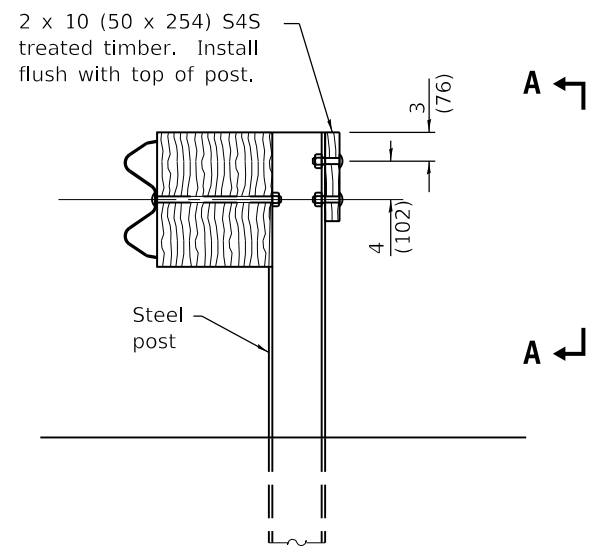

**ELEVATION WITH
W-BEAM GUARDRAIL**

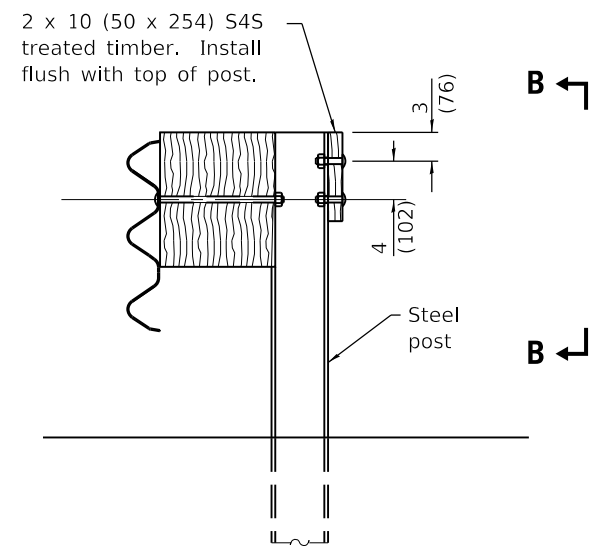

**ELEVATION WITH
THRIE-BEAM GUARDRAIL**

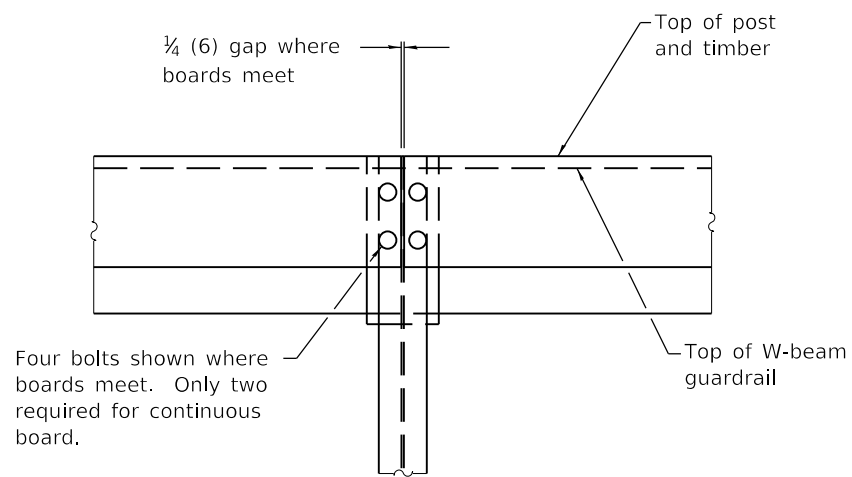

VIEW A-A

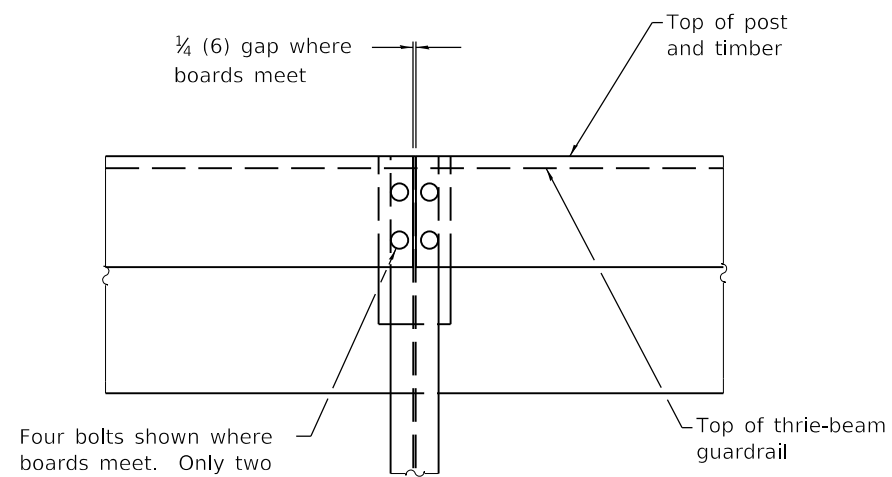

VIEW B-B

GENERAL NOTES

For details of guardrail elements not shown, see Standard 630001.

All dimensions are in inches (millimeters) unless otherwise shown.

Illinois Department of Transportation

PASSED January 1, 2017
Michael Beard
 ENGINEER OF POLICY AND PROCEDURES

APPROVED January 1, 2017
Marcus M. Adams
 ENGINEER OF DESIGN AND ENVIRONMENT

ISSUED 1-1-17

DATE	REVISIONS
1-1-17	New standard.

**BACK SIDE PROTECTION
OF GUARDRAIL**

STANDARD 630116

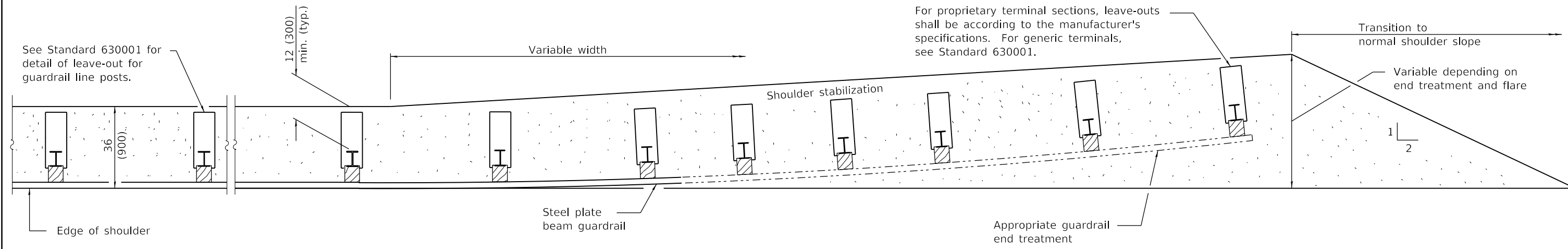

PLAN

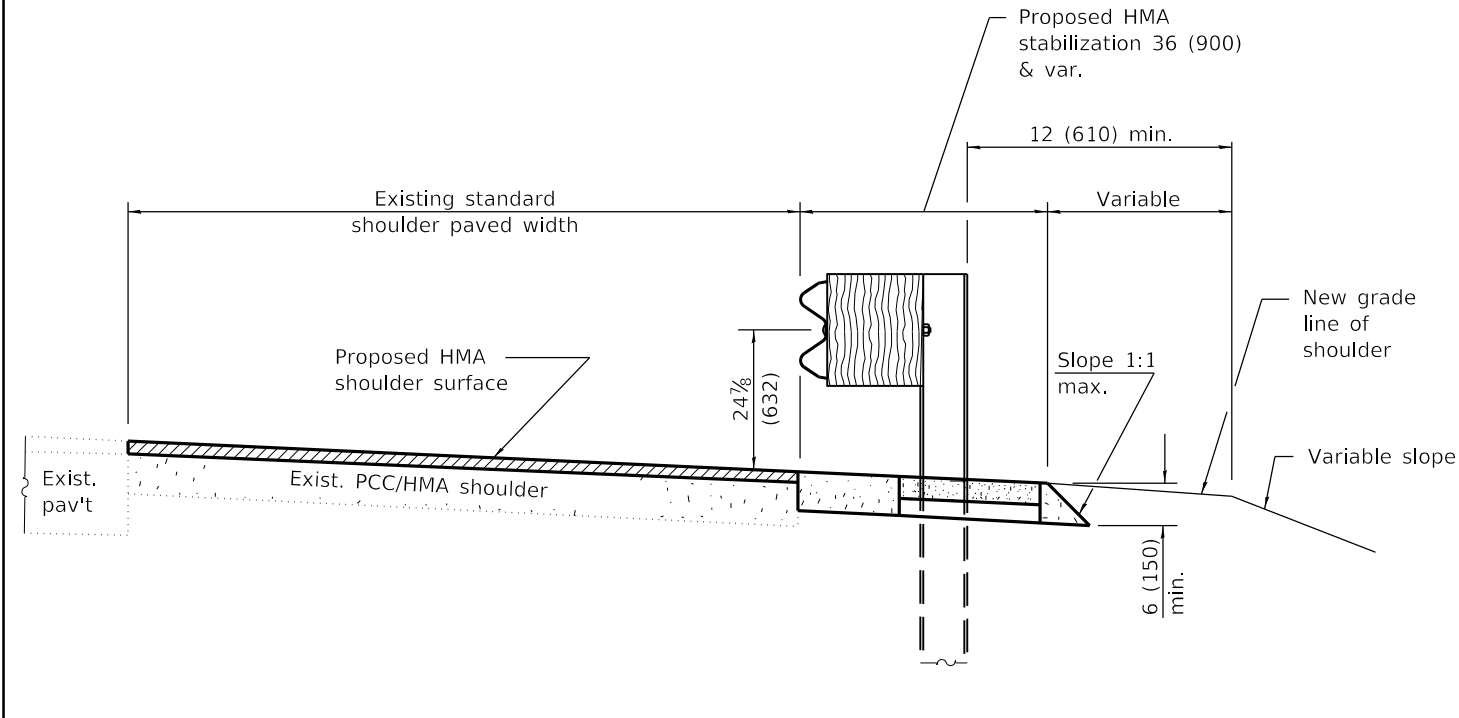

RESURFACING

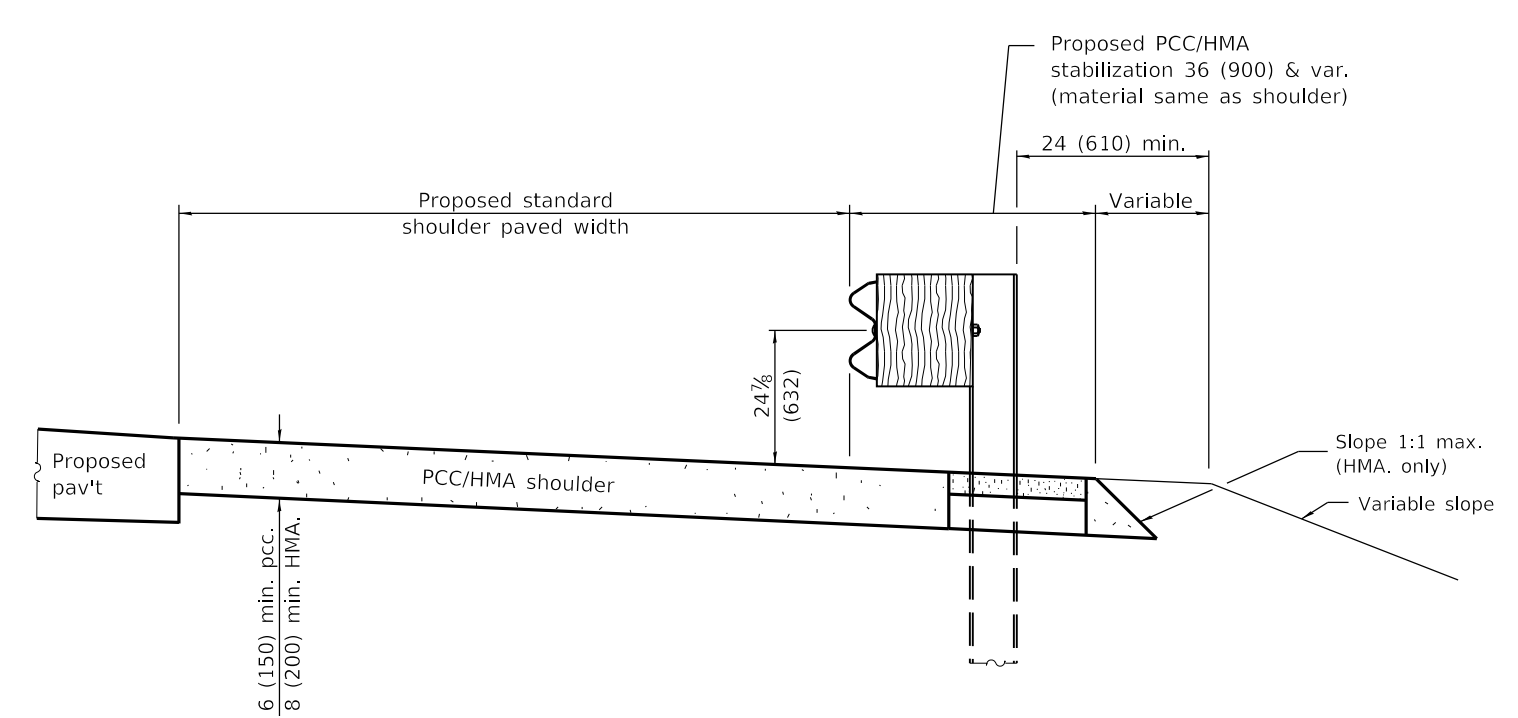

NEW CONSTRUCTION

GENERAL NOTES

See Standard 482001, 482006, 483001 and 630001 for details not shown.

All dimensions are in inches (millimeters) unless otherwise shown.

Illinois Department of Transportation

PASSED January 1, 2017
Michael Beard
 ENGINEER OF POLICY AND PROCEDURES

APPROVED January 1, 2017
Maureen M. Beck
 ENGINEER OF DESIGN AND ENVIRONMENT

ISSUED 1-1-97

DATE	REVISIONS
1-1-17	Revised leave-outs, moved dimensions to Standard 630001.
1-1-09	Switched units to English (metric).

**PCC / HMA
 STABILIZATION AT STEEL
 PLATE BEAM GUARDRAIL**

STANDARD 630201-07

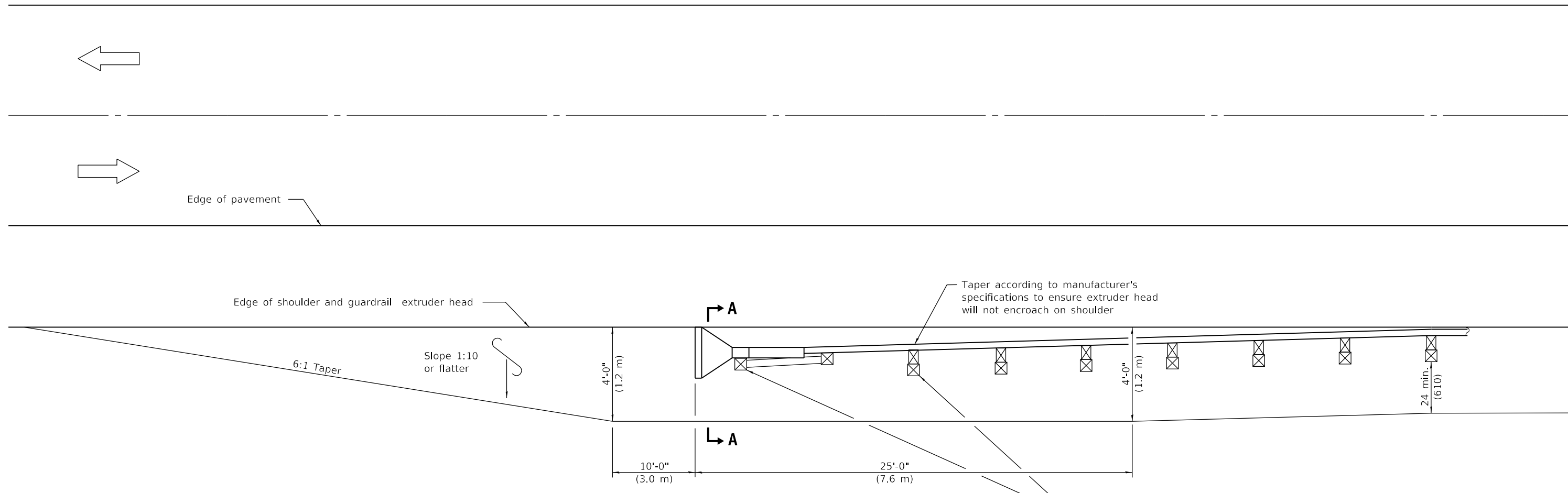

**SHOULDER WIDENING TRANSITION
FOR TANGENT TERMINAL**

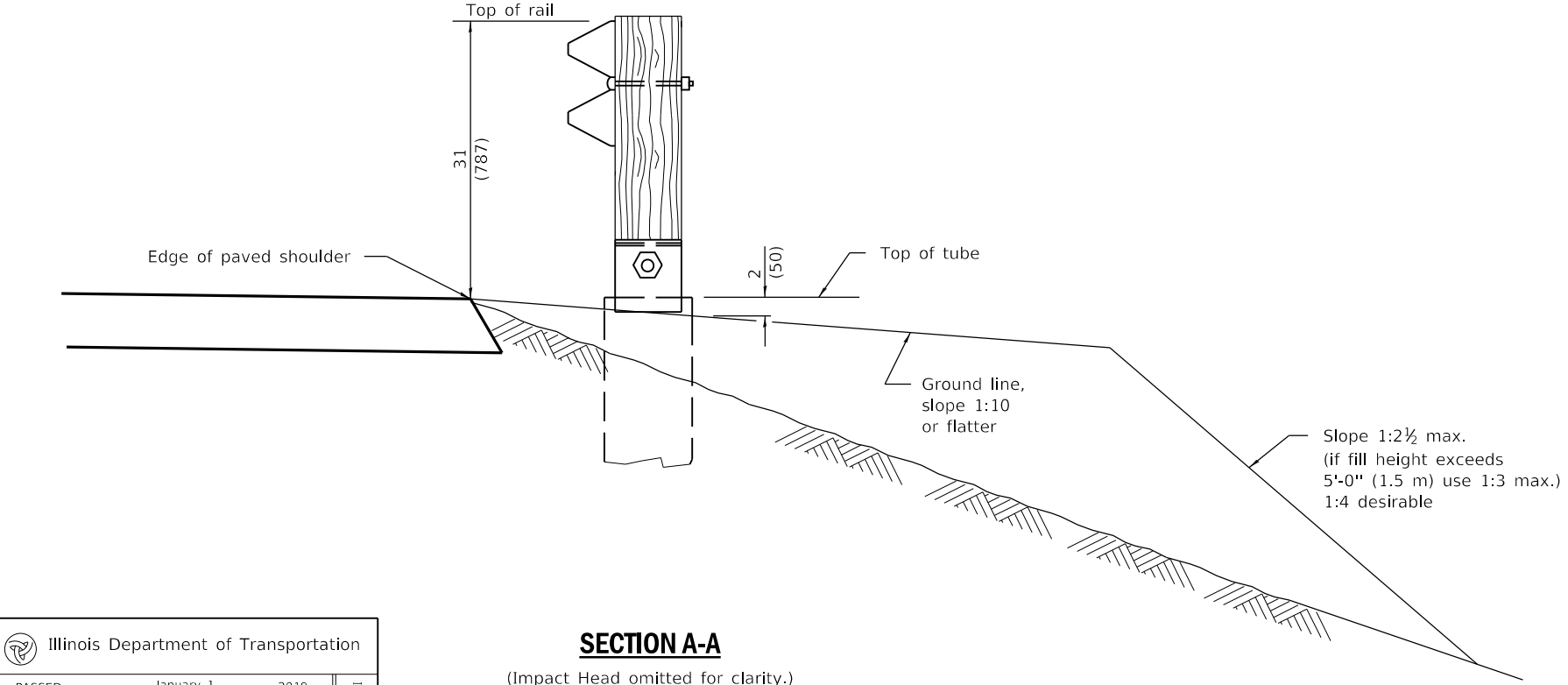

SECTION A-A
(Impact Head omitted for clarity.)

Beginning length of need point varies by manufacturer. Typically occurs between posts 1 and 3.

GENERAL NOTES

All slope ratios are expressed as units of vertical displacement to units of horizontal displacement (V:H).

All dimensions are in inches (millimeters) unless otherwise shown.

DATE	REVISIONS
1-1-19	Removed pay limits. Revised notes regarding the taper/flare and length of need point.
1-1-18	Omitted posts from 'Pay limits of other type'.

**SHOULDER WIDENING FOR
TYPE 1 (SPECIAL)
GUARDRAIL TERMINALS**
(Sheet 1 of 2)

STANDARD 630301-09

Illinois Department of Transportation

PASSED January 1, 2019
Michael Bond
ENGINEER OF POLICY AND PROCEDURES

APPROVED January 1, 2019
John E. ...
ENGINEER OF DESIGN AND ENVIRONMENT

ISSUED 1-1-00

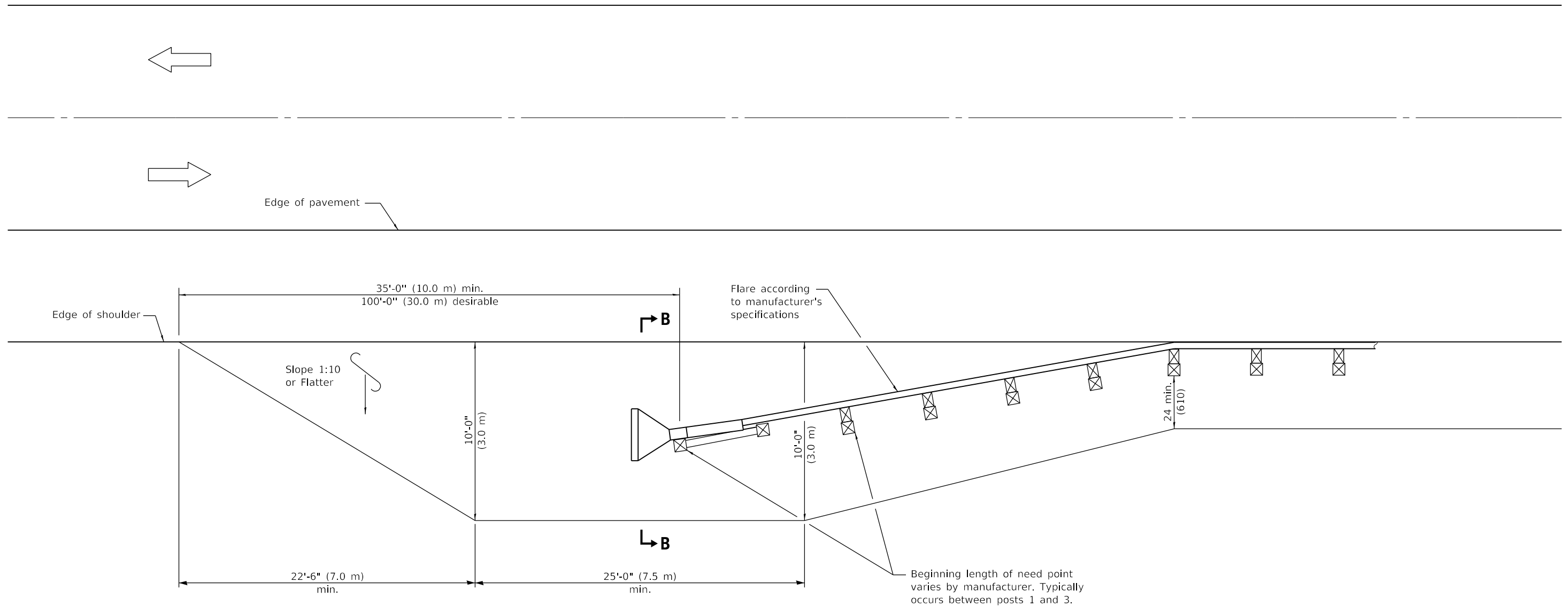

**SHOULDER WIDENING TRANSITION
FOR FLARED TERMINAL**

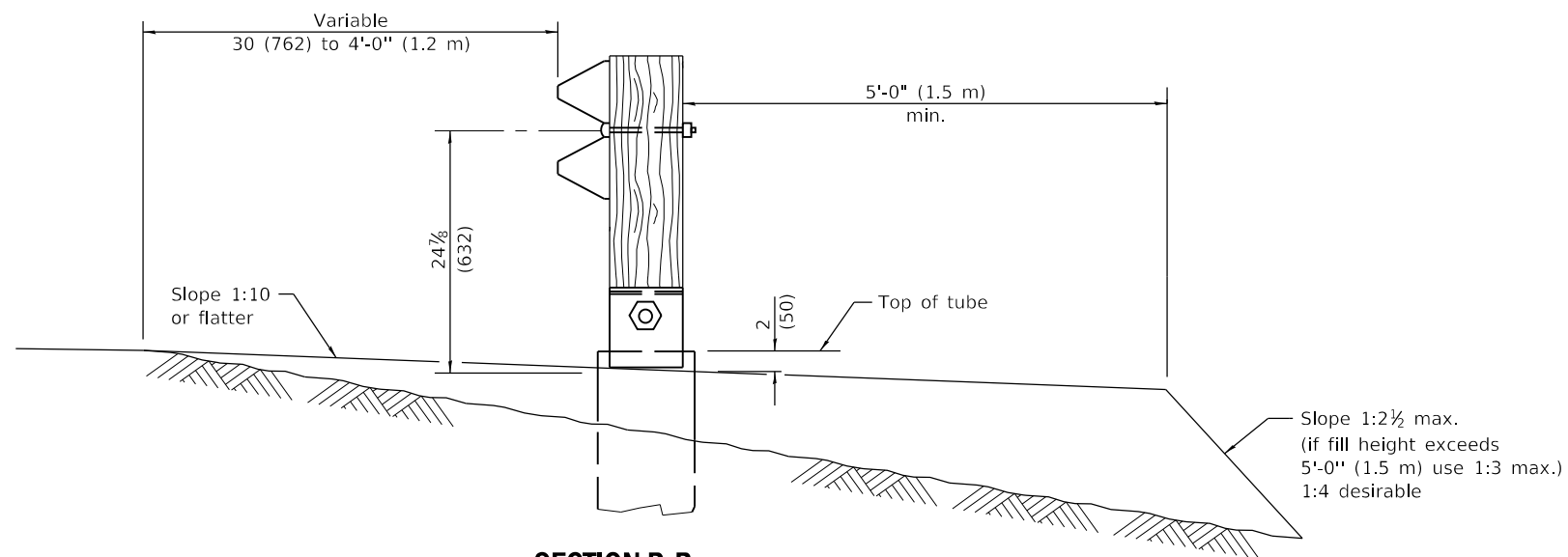

SECTION B-B
(Impact Head omitted for clarity.)

**SHOULDER WIDENING FOR
TYPE 1 (SPECIAL)
GUARDRAIL TERMINALS**

(Sheet 2 of 2)

STANDARD 630301-09

<p>Illinois Department of Transportation</p>	<p>PASSED January 1, 2019</p> <p><i>Michael Bond</i></p> <p>ENGINEER OF POLICY AND PROCEDURES</p> <p>APPROVED January 1, 2019</p> <p><i>J. E. C.</i></p> <p>ENGINEER OF DESIGN AND ENVIRONMENT</p>	<p>ISSUED 1-1-00</p>
--	--	----------------------

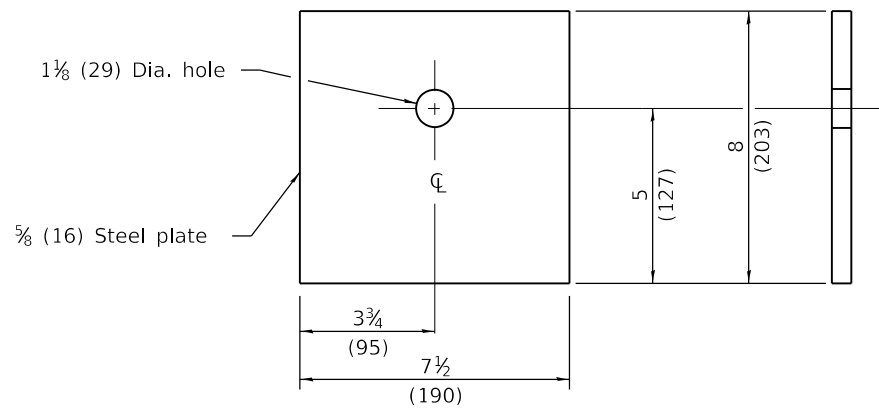

BEARING PLATE K

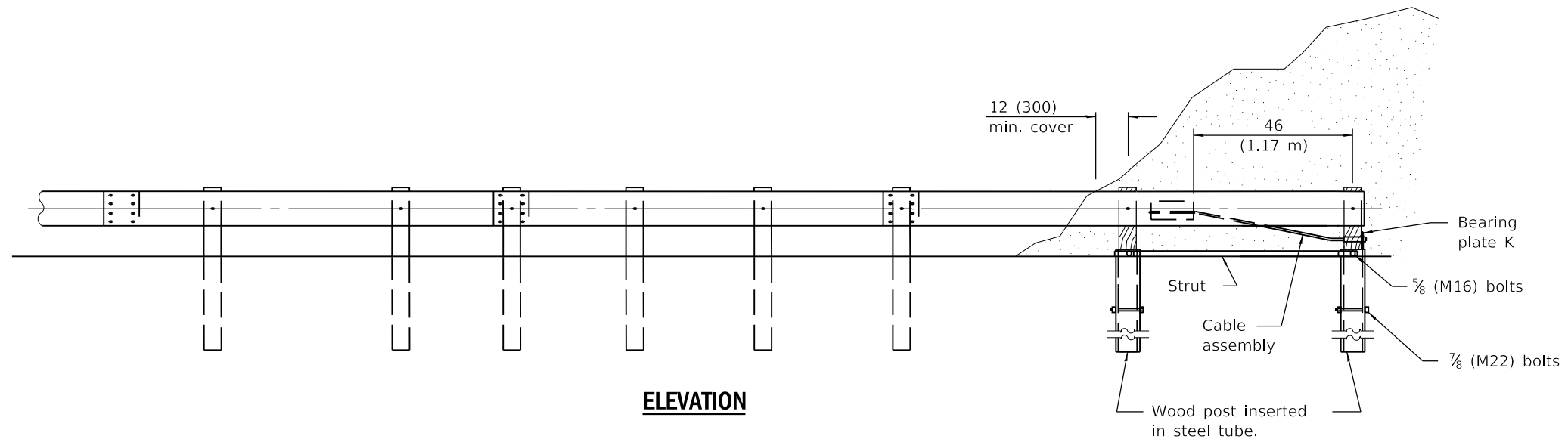

ELEVATION

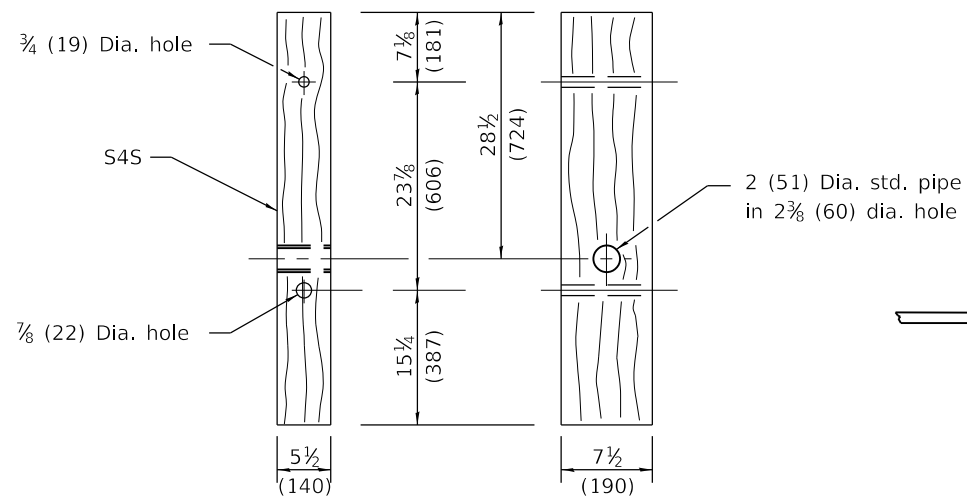

FRONT

SIDE

WOOD POST

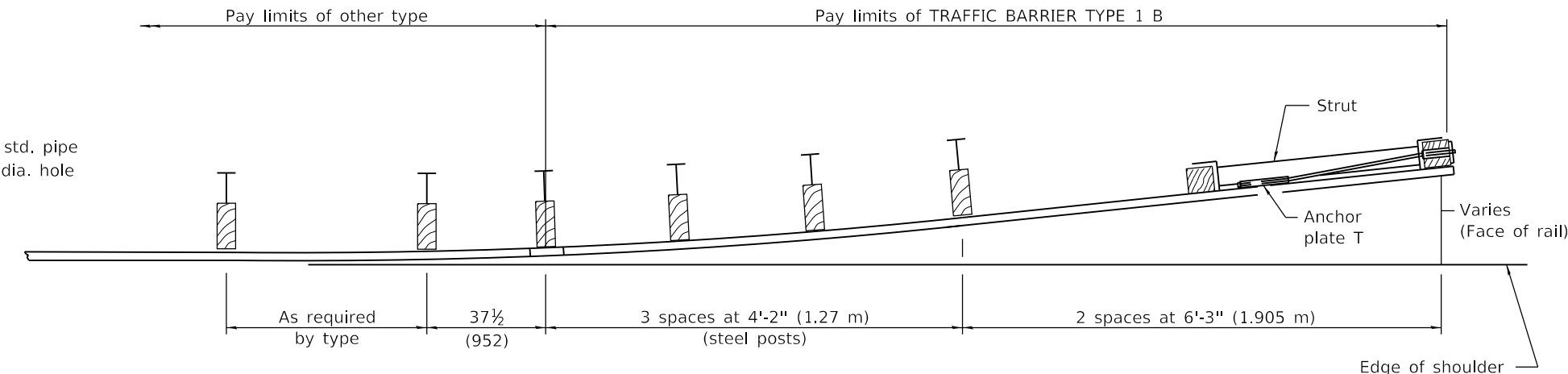

PLAN

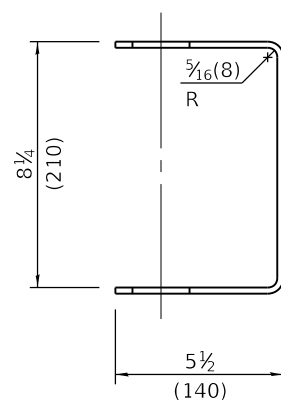

YOKE

3/16 (5) thick steel

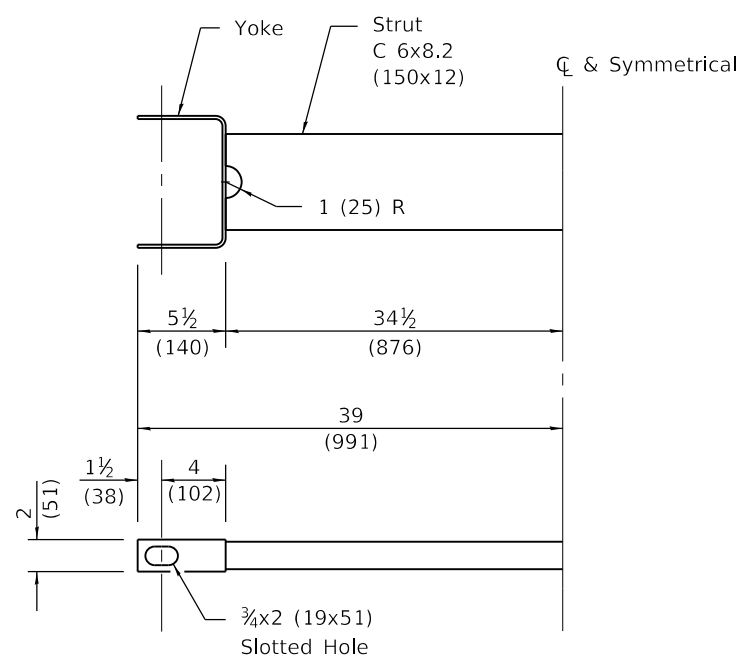

CABLE STRUT

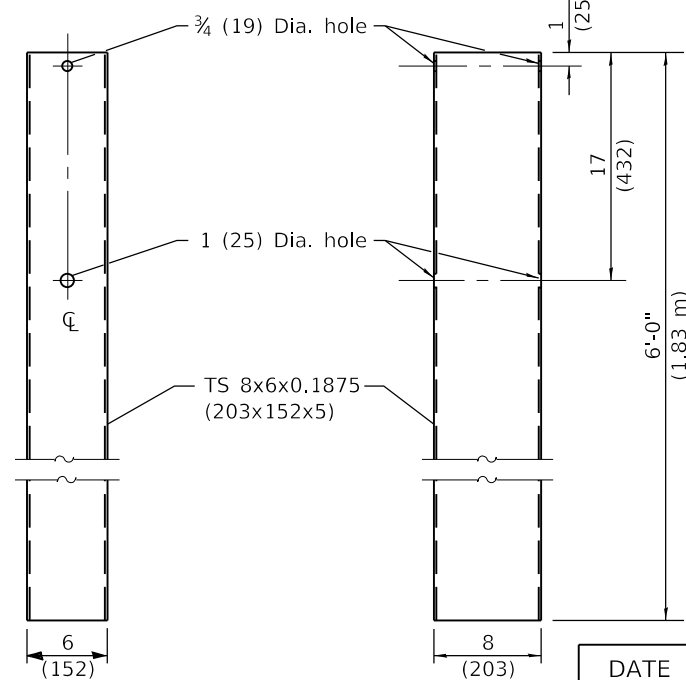

FRONT

SIDE

STEEL TUBE

GENERAL NOTES

See Standard 630001 for details of guardrail not shown.

The bearing plate K shall be held in position by two eight penny nails driven into the post and bent over the top of the plate.

All dimensions are in inches (millimeters) unless otherwise shown.

DATE	REVISIONS
1-1-11	Revised steel tube length to 6'-0" (1.83 m).
1-1-10	Increased steel tube length, corrected hole locations in tube.

**TRAFFIC BARRIER
TERMINAL, TYPE 1B**

STANDARD 631006-08

Illinois Department of Transportation

PASSED January 1, 2011
Michael Beard
 ENGINEER OF POLICY AND PROCEDURES

APPROVED January 1, 2011
Scott Schick
 ENGINEER OF DESIGN AND ENVIRONMENT

ISSUED 1-1-97
 16-1

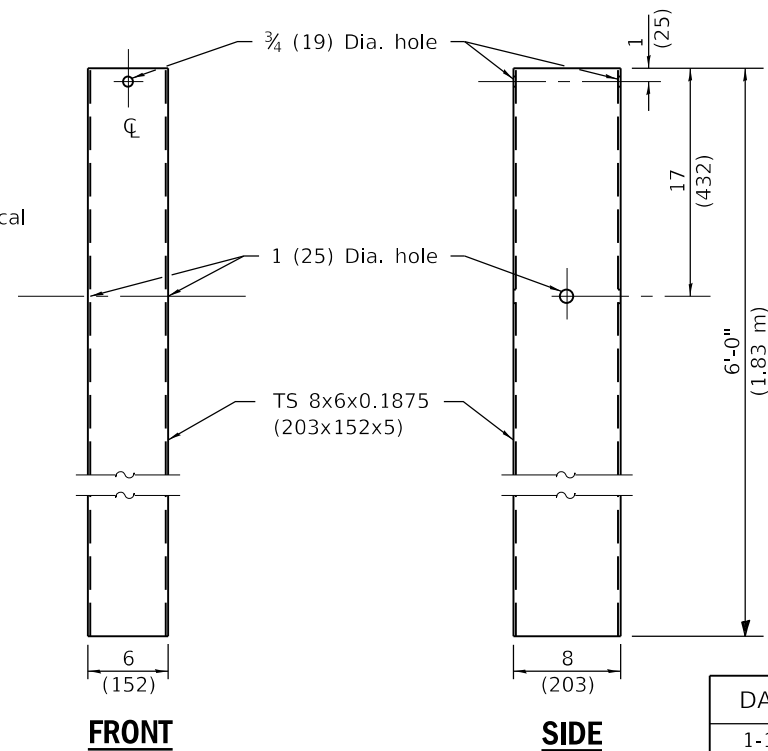
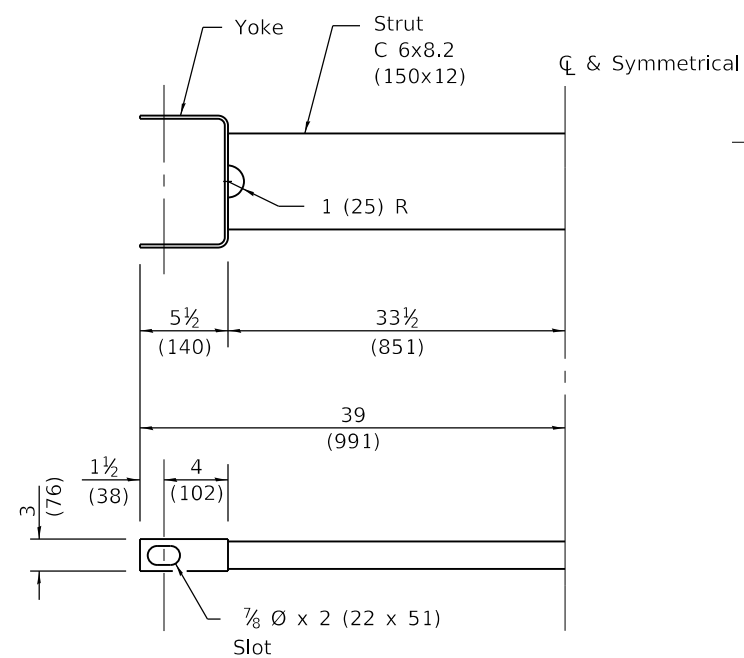
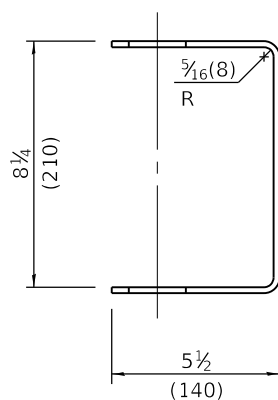
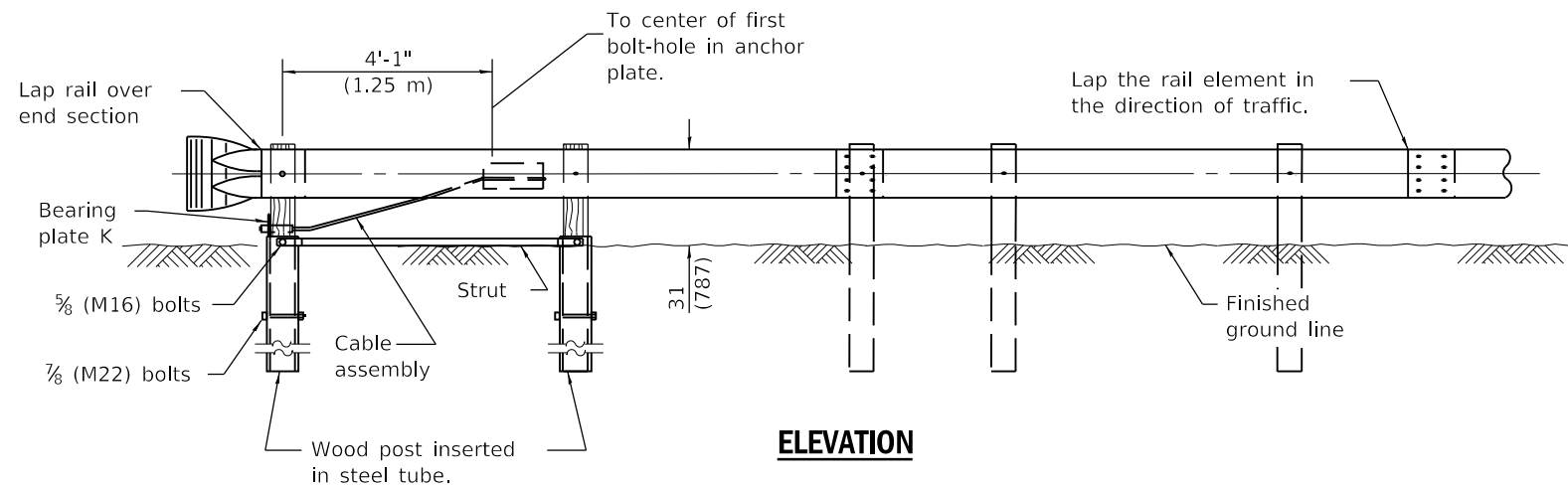
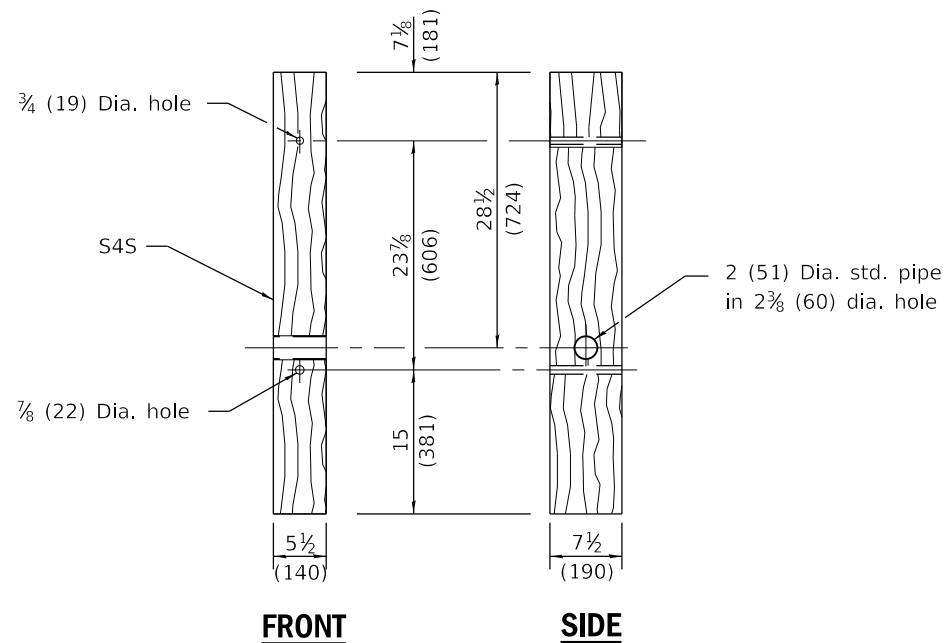
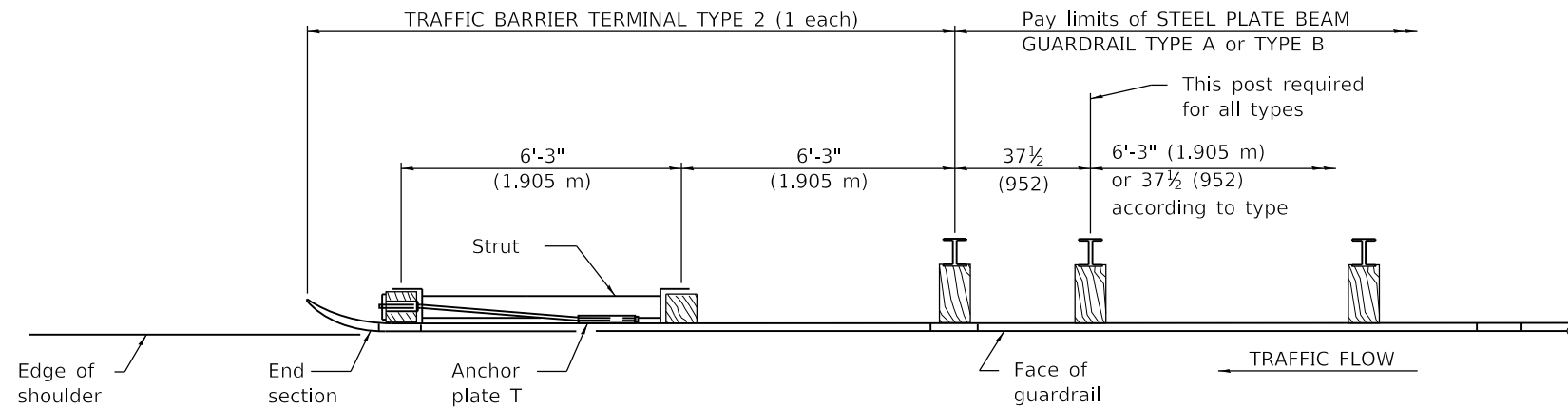
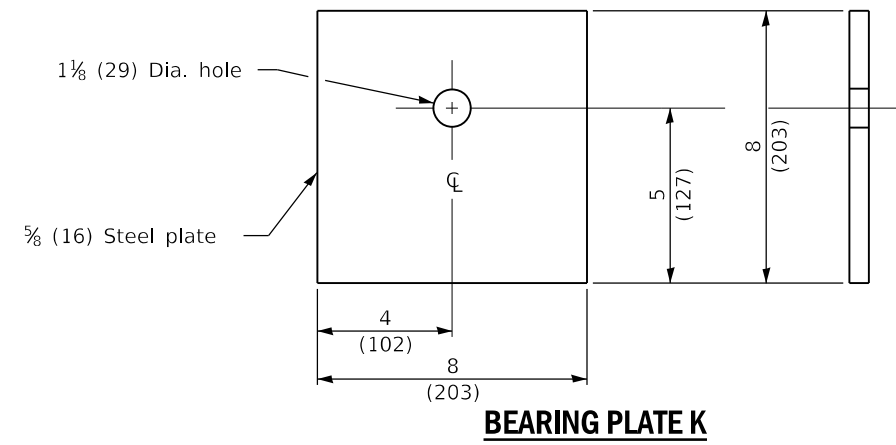

GENERAL NOTES

See Standard 630001 for details of guardrail not shown.

The bearing plate K shall be held in position by two eight penny nails driven into the post and bent over the top of the plate.

All dimensions are in inches (millimeters) unless otherwise shown.

DATE	REVISIONS
1-1-17	Revised wood post length and hole spacing.
1-1-13	Corrected metric dimension for BEARING PLATE K. Changed pipe dia. in wood post.

TRAFFIC BARRIER TERMINAL, TYPE 2

STANDARD 631011-10

Illinois Department of Transportation

PASSED January 1, 2017
Michael Beard
 ENGINEER OF POLICY AND PROCEDURES

APPROVED January 1, 2017
Marcus M. Beck
 ENGINEER OF DESIGN AND ENVIRONMENT

ISSUED 1-1-97

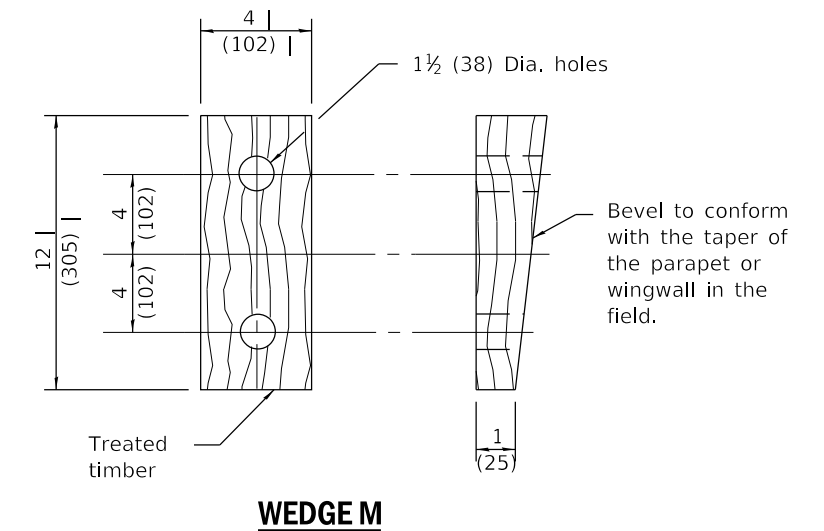
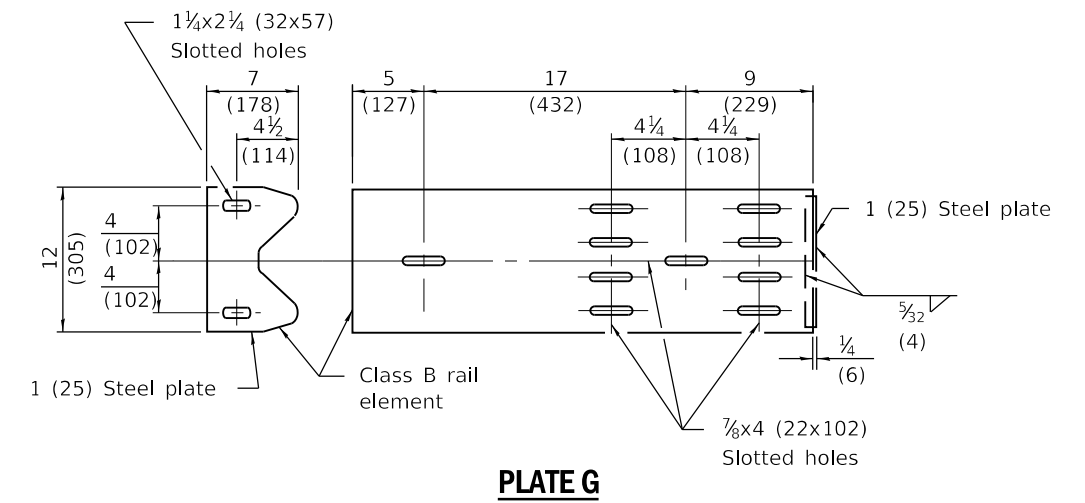
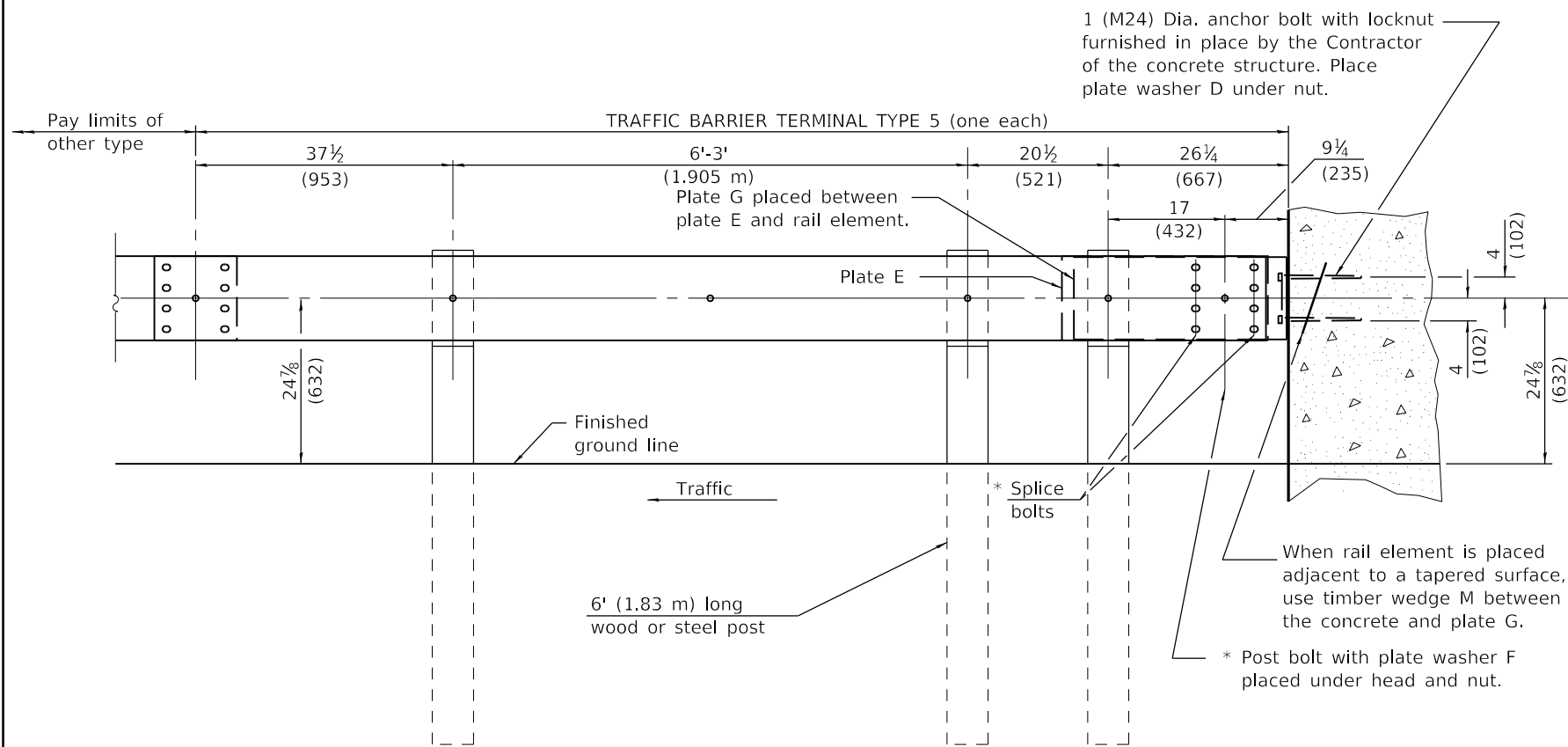

TYPE 5 - CONCRETE BRIDGE PARAPET

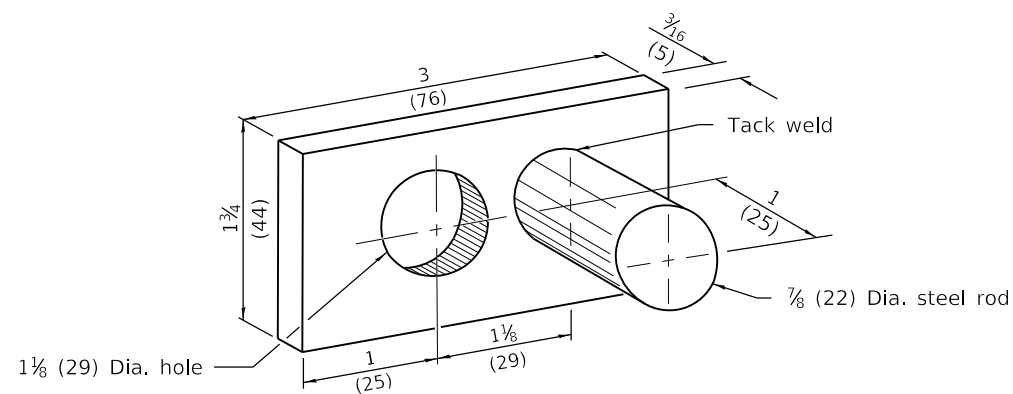
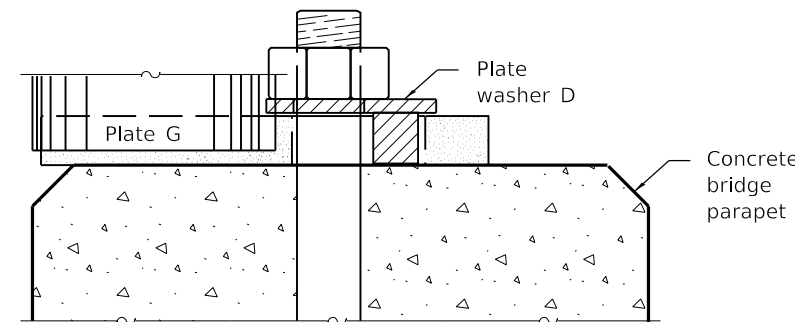

PLATE WASHER D



PLACEMENT OF PLATE WASHER D

(PLAN)

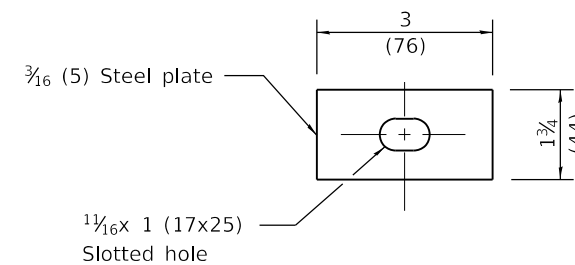

PLATE WASHER F

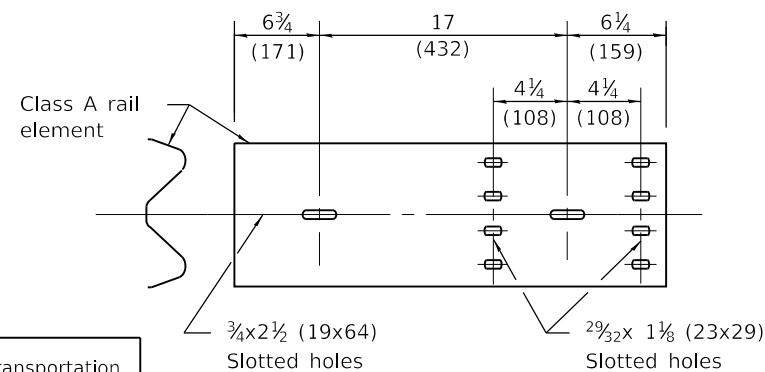

PLATE E

GENERAL NOTES

Install plate washer D so the 1 (25) projection fills the remainder of the slotted holes in the 1 (25) end plate on plate G after the 1 (M24) dia. bolts are in place.

* When an expansion joint exists below the connector, bolts shall be provided with a locknut or double nuts and shall be tightened only to a point that will allow plate G to be free to move.

See Standard 630001 for details of guardrail not shown.

All dimensions are in inches (millimeters) unless otherwise shown.

DATE	REVISIONS
1-1-15	Revised post spacing dimensions on elevation.
1-1-09	Switched units to English (metric).

TRAFFIC BARRIER TERMINAL, TYPE 5

STANDARD 631026-06

Illinois Department of Transportation

PASSED January 1, 2015
Michael Beard
 ENGINEER OF POLICY AND PROCEDURES

APPROVED January 1, 2015
[Signature]
 ENGINEER OF DESIGN AND ENVIRONMENT

ISSUED 1-1-15

PARAPET OR WINGWALL

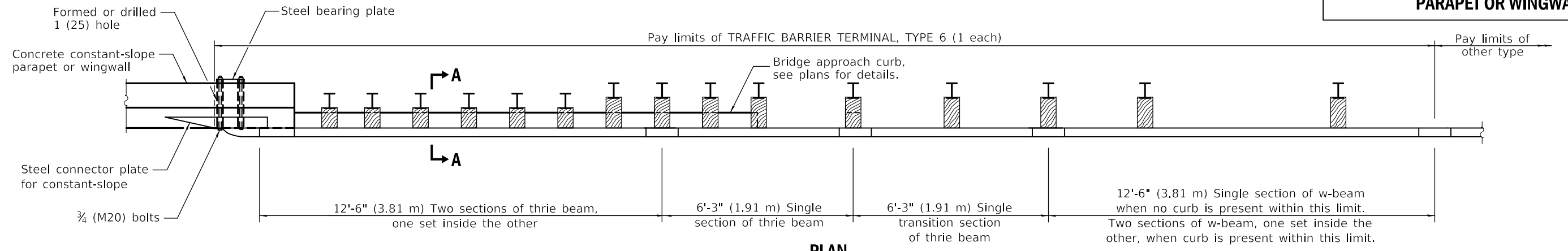

PLAN

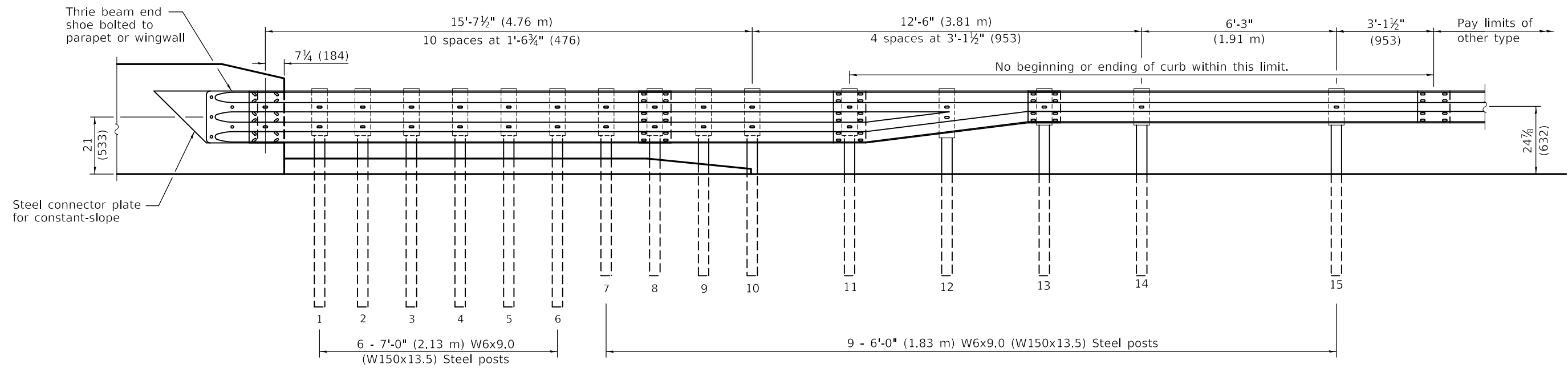

ELEVATION

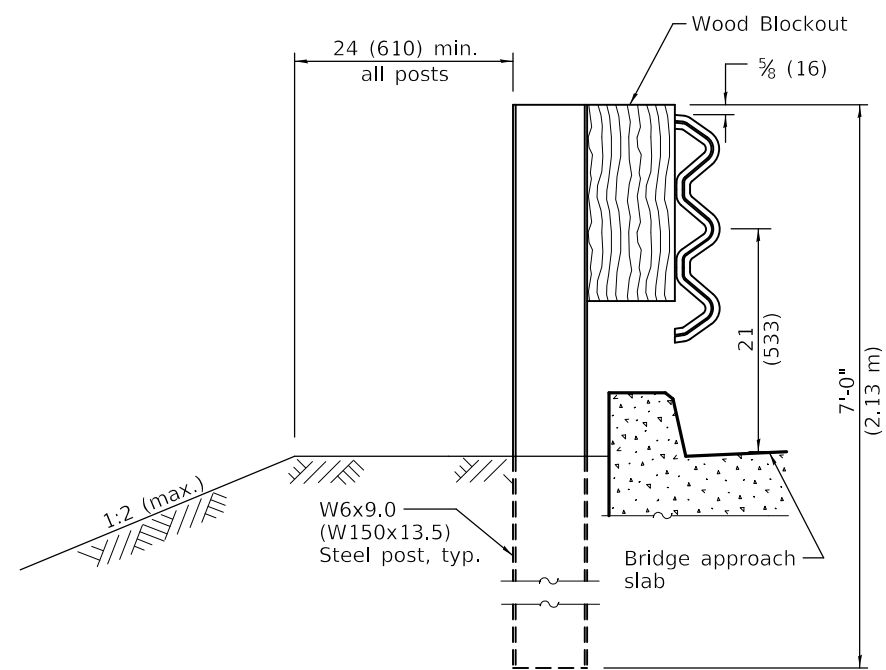

SECTION A-A

GENERAL NOTES

- See Standard 630001 for details of guardrail not shown.
- Thrie beam rail shall be bolted to block-out at all posts.
- All slope ratios are expressed as units of vertical displacement to units of horizontal displacement (V:H).
- All dimensions are in inches (millimeters) unless otherwise shown.

DATE	REVISIONS
1-1-23	Removed two posts, revised blockouts, and removed notes on sheet 4.
1-1-21	Added Detail A and revised plate dimensions on sheet 4.

**TRAFFIC BARRIER
TERMINAL, TYPE 6**

(Sheet 1 of 4)

STANDARD 631031-18

Illinois Department of Transportation

PASSED January 1, 2023

ENGINEER OF SAFETY PROG. & ENGINEERING

APPROVED January 1, 2023

ENGINEER OF DESIGN AND ENVIRONMENT

ISSUED 1-1-97

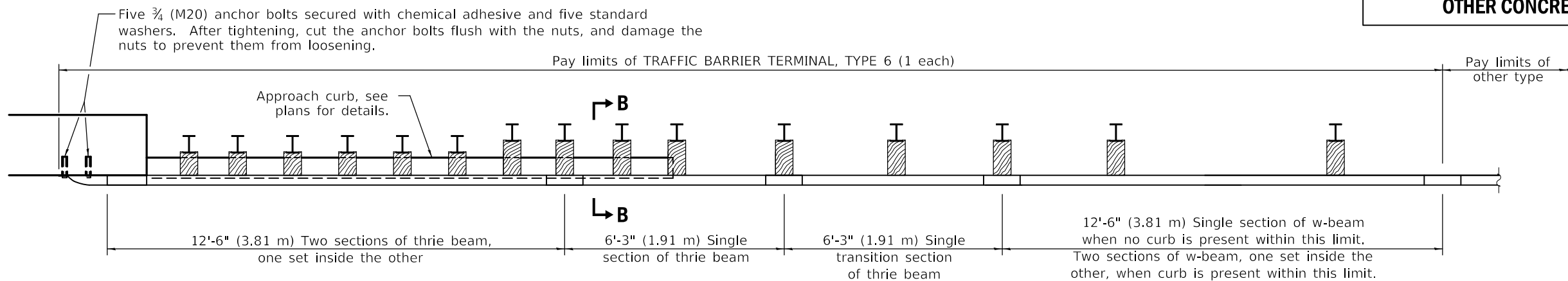

PLAN

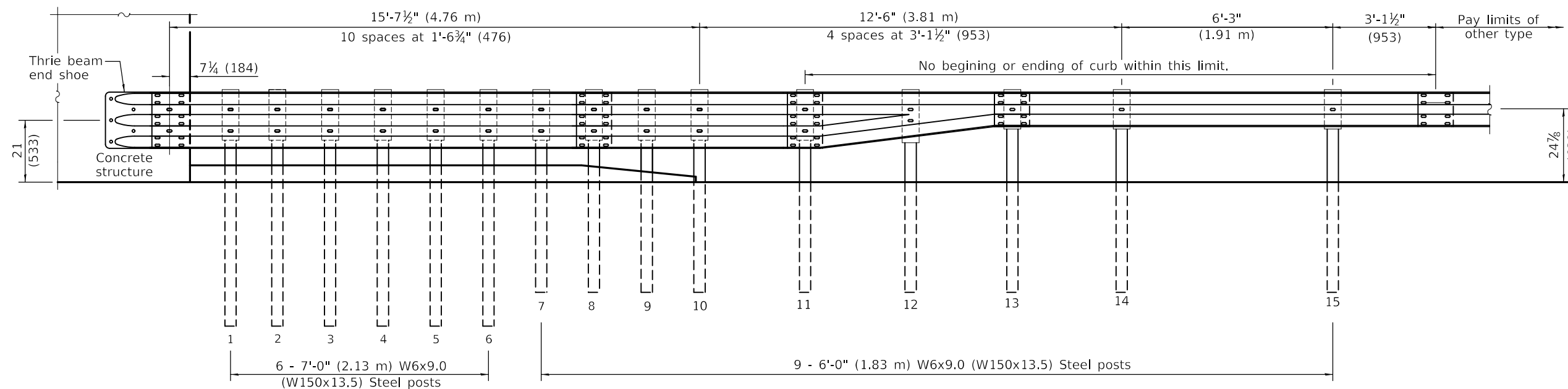

ELEVATION

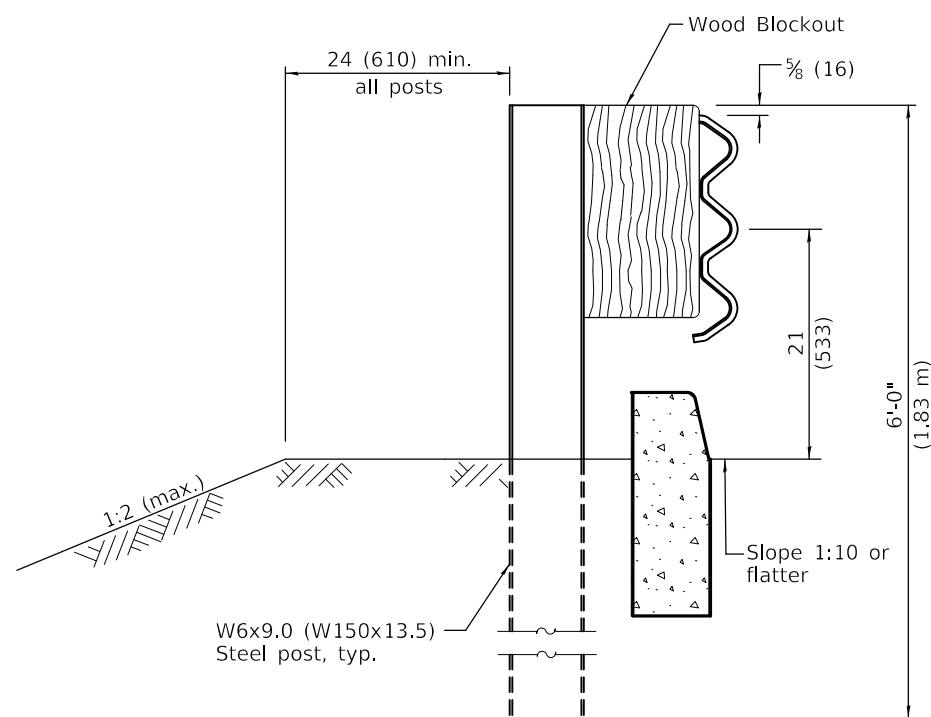

SECTION B-B

Illinois Department of Transportation

PASSED January 1, 2023

ENGINEER OF SAFETY PROG. & ENGINEERING

APPROVED January 1, 2023

ENGINEER OF DESIGN AND ENVIRONMENT

ISSUED 1-1-97

**TRAFFIC BARRIER
TERMINAL, TYPE 6**

(Sheet 2 of 4)

STANDARD 631031-18

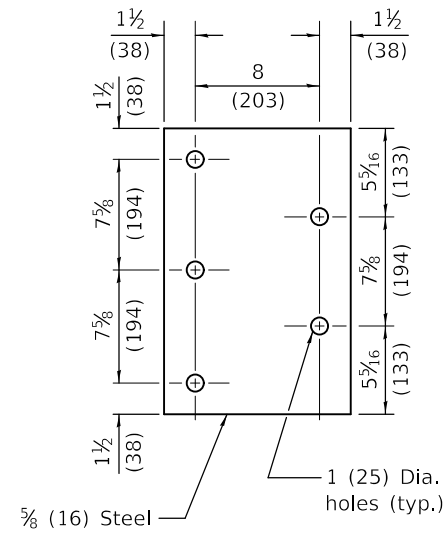

STEEL BEARING PLATE FOR F-SHAPE PARAPET

(5 each individual 5x5x5/8 (125x125x16) steel plates with centered 1 (25) holes may be substituted for the plate shown.)

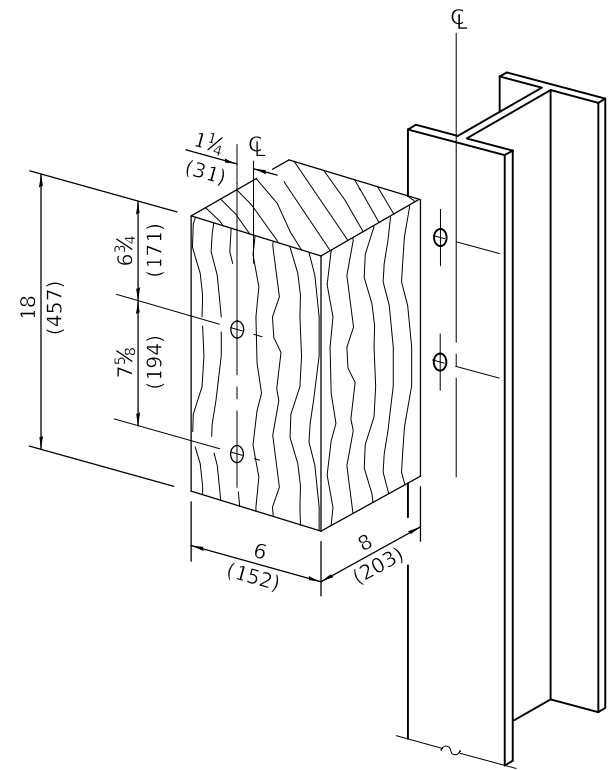

POSTS 1-6 WOOD BLOCKOUT DETAIL

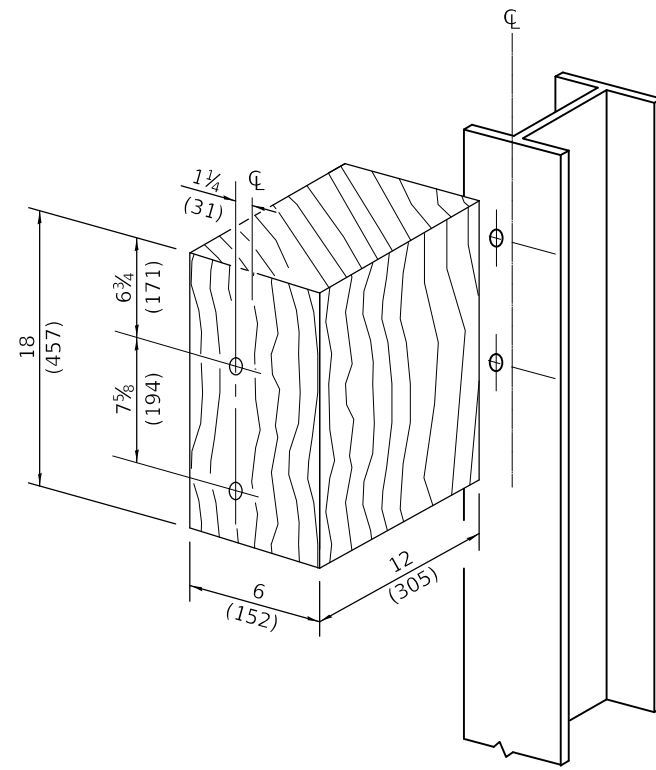

POSTS 7-11 WOOD BLOCKOUT DETAIL

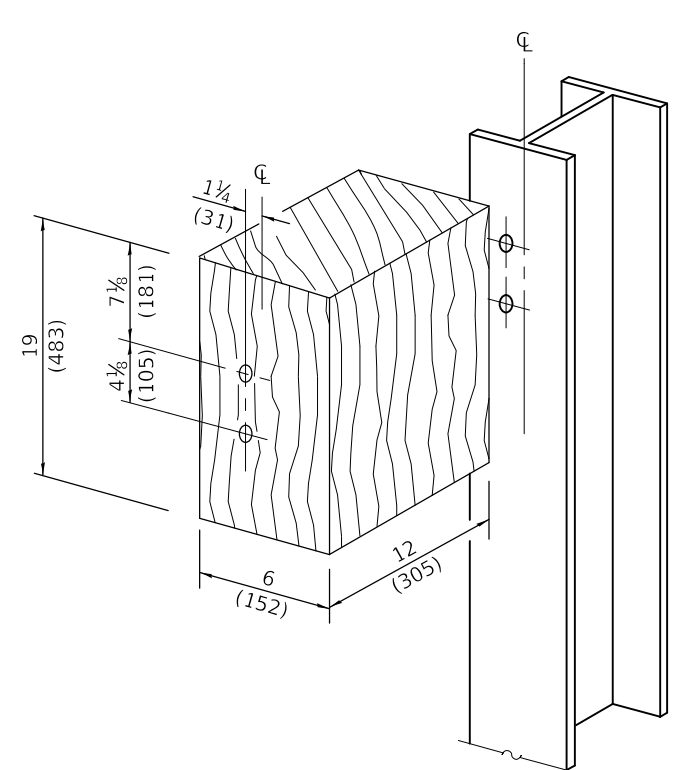

POST 12 WOOD BLOCKOUT DETAIL

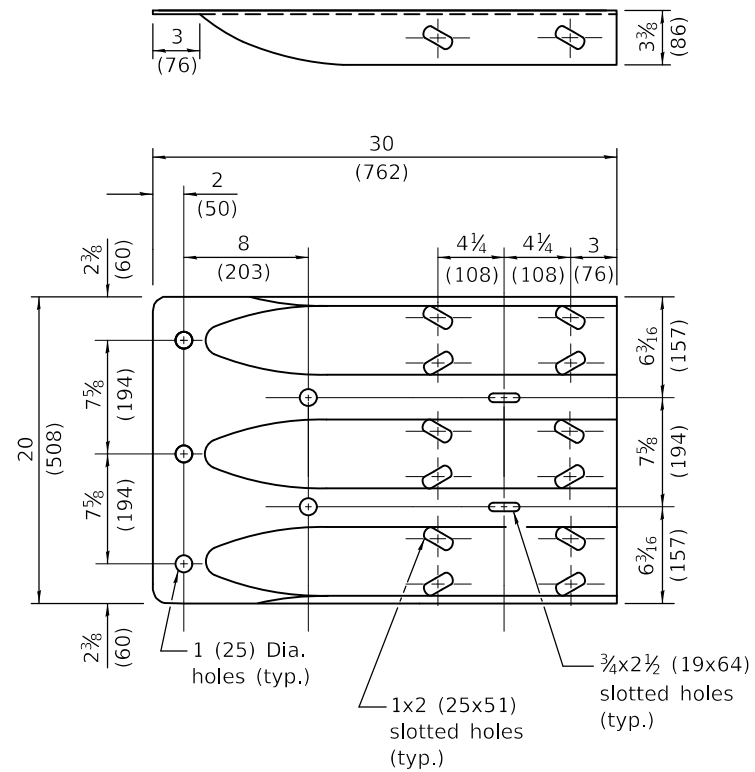

THREE BEAM END SHOE DETAIL

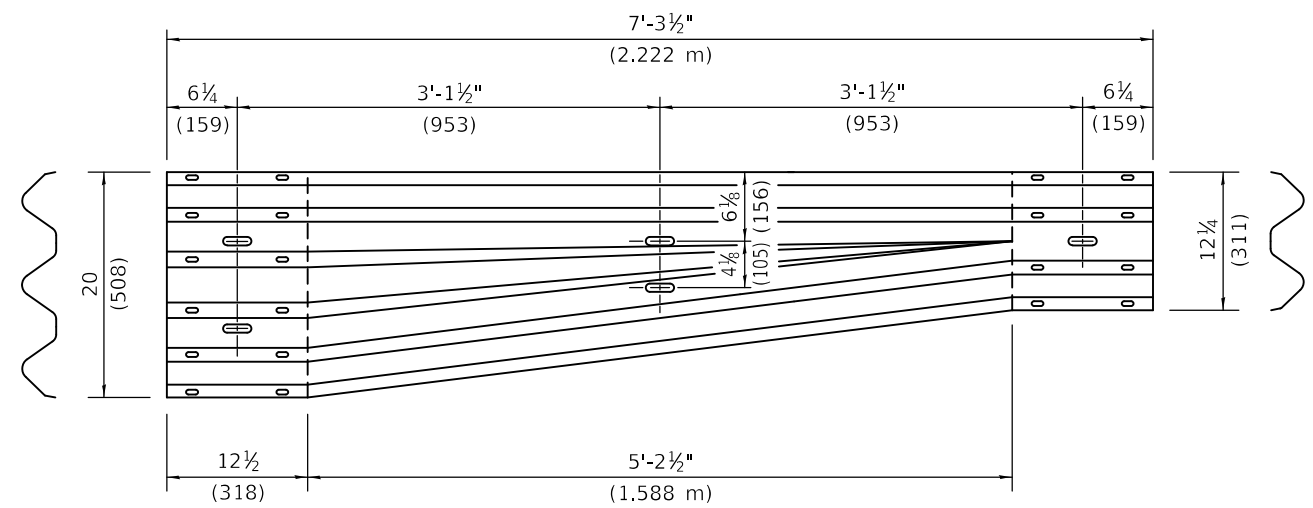

TRANSITION SECTION
(10 gauge (3.4) rail element)

Illinois Department of Transportation

PASSED January 1, 2023

ENGINEER OF SAFETY PROG. & ENGINEERING

APPROVED January 1, 2023

ENGINEER OF DESIGN AND ENVIRONMENT

ISSUED 1-1-2023

**TRAFFIC BARRIER
TERMINAL, TYPE 6**

(Sheet 3 of 4)

STANDARD 631031-18

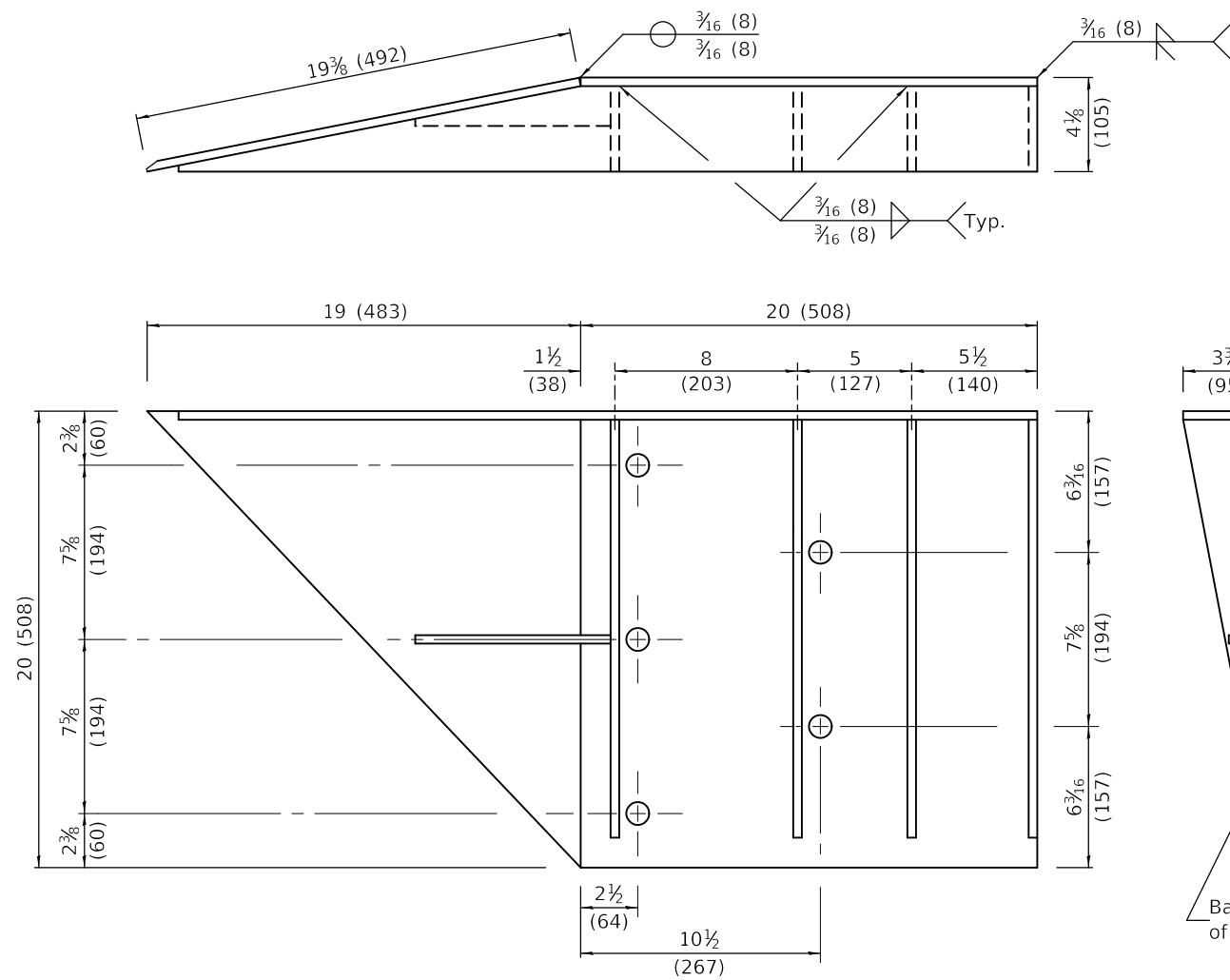

WELDING INSTRUCTION
(Back side of plate shown)

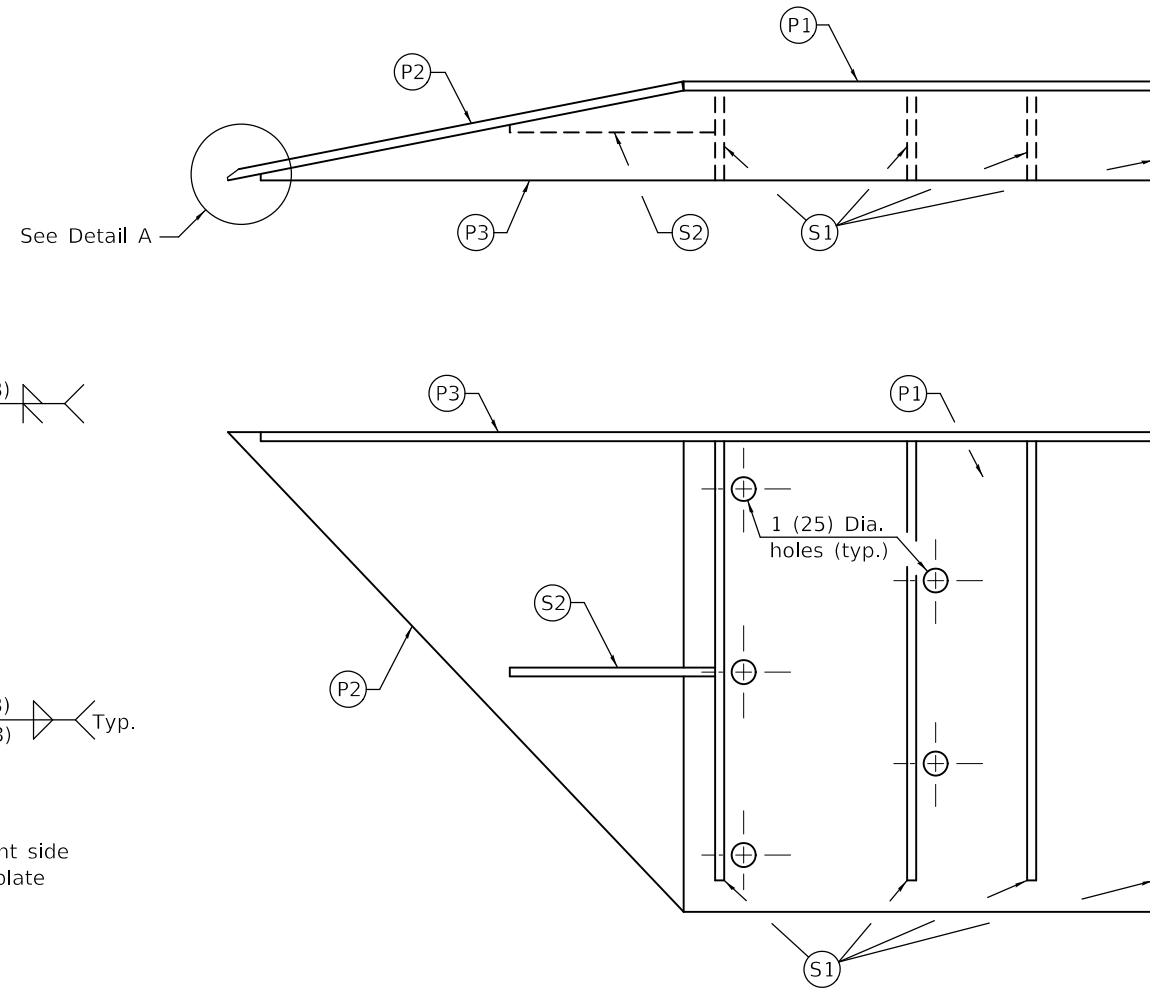
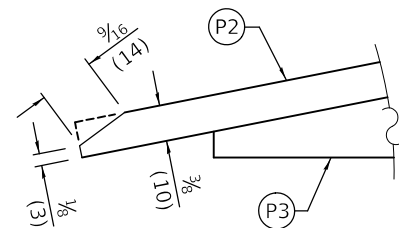

PLATE AND STIFFENER IDENTIFICATION
(Back side of plate shown)



DETAIL A
(Bevel front corner of plate P2 as shown for handling purposes.)

CONNECTOR PLATE DIMENSION (PER ASSEMBLY)				
PLATE	QUANTITY	SHAPE	SIZE A x B x C x D x E	THICKNESS
P1	1		20 x 20 (508 x 508)	3/8 (10)
P2	1		19 3/8 x 20 x 27 3/16 (492 x 508 x 706)	3/8 (10)
P3	1		20 x 3 3/4 x 37 5/8 x 1/4 x 17 15/16 (508 x 95 x 956 x 6 x 456)	3/8 (10)
S1	4		18 5/16 x 1/4 x 18 5/8 x 3 3/4 (465 x 6 x 473 x 95)	3/8 (10)
S2	1		1 5/16 x 1 3/4 x 8 1/16 x 3/8 x 6 7/8 (33 x 44 x 205 x 10 x 175)	3/8 (10)

Illinois Department of Transportation

PASSED January 1, 2023

Cynthia D. [Signature]
ENGINEER OF SAFETY PROG. & ENGINEERING

APPROVED January 1, 2023

[Signature]
ENGINEER OF DESIGN AND ENVIRONMENT

ISSUED 1-1-97

STEEL CONNECTOR PLATE FOR CONSTANT SLOPE PARAPET

**TRAFFIC BARRIER
TERMINAL, TYPE 6**

(Sheet 4 of 4)

STANDARD 631031-18

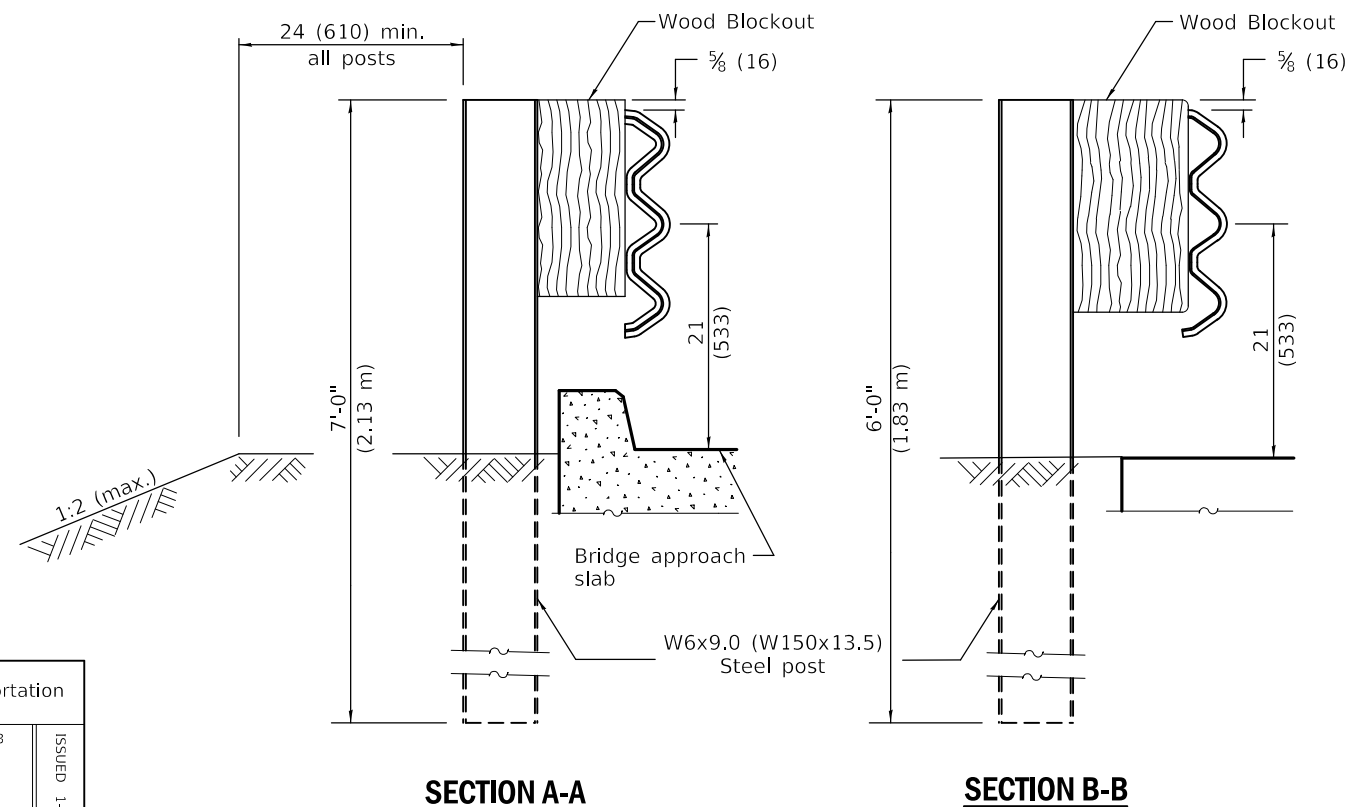
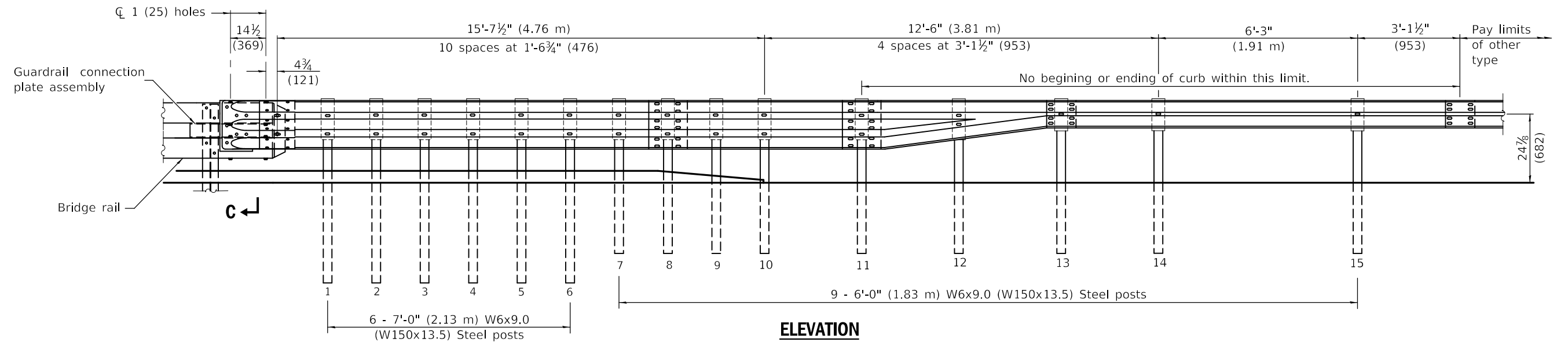
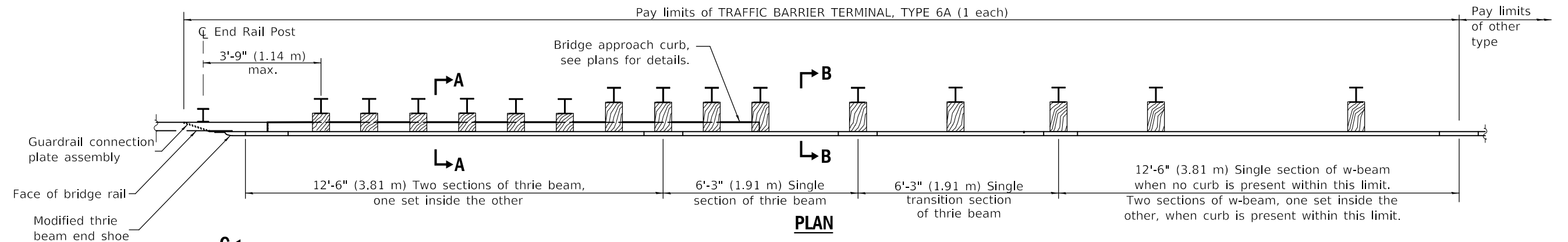

GENERAL NOTES

This standard shows attachment to side mounted bridge rail, Type SMX. Side mounted bridge rail, Type SM is similar.

See Standard 630001 for details of guardrail not shown.

Thrie beam rail shall be bolted to block-out at all posts.

All slope ratios are expressed as units of vertical displacement to units of horizontal displacement (V:H).

All dimensions are in inches (millimeters) unless otherwise shown.

DATE	REVISIONS
1-1-23	Updated bridge rail connection to match the new Type SMX.
	Revised post spacing, blockouts, and details to match other TBTs.
1-1-17	Revised length of thrie beam.
	Revised length of posts.

**TRAFFIC BARRIER
TERMINAL, TYPE 6A**

(Sheet 1 of 3)

STANDARD 631032-10

Illinois Department of Transportation

PASSED January 1, 2023

Cynthia D. [Signature]
ENGINEER OF SAFETY PROG. & ENGINEERING

APPROVED January 1, 2023

[Signature]
ENGINEER OF DESIGN AND ENVIRONMENT

ISSUED 1-1-2003

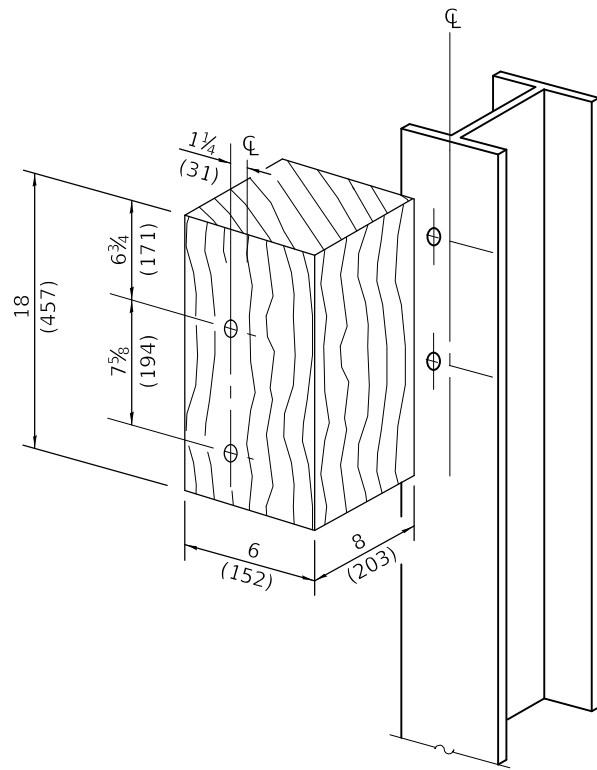

POSTS 1-6 WOOD BLOCKOUT DETAIL

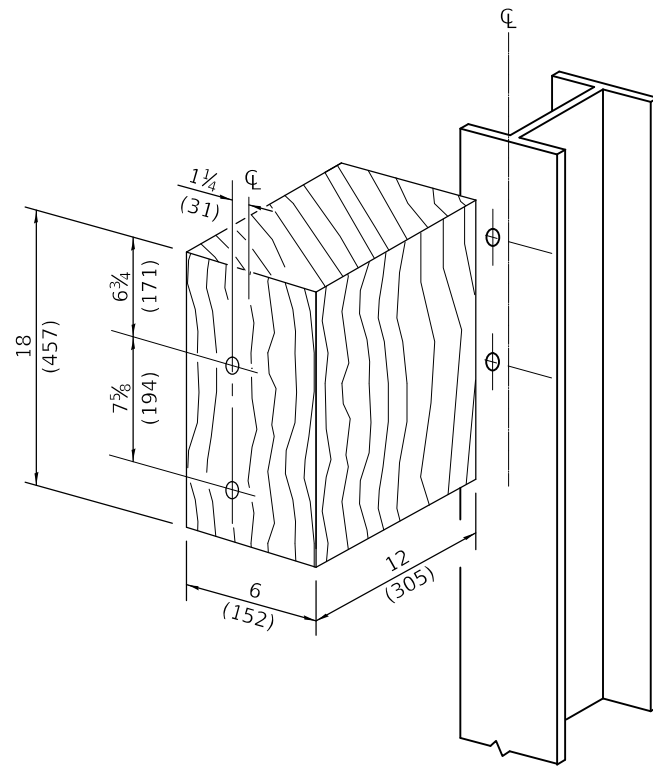

POSTS 7-11 WOOD BLOCKOUT DETAIL

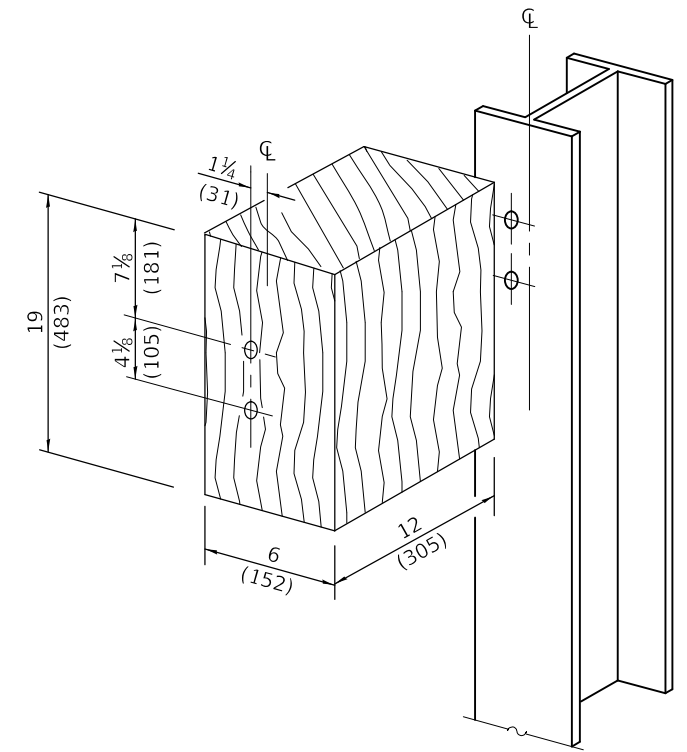

POST 12 WOOD BLOCKOUT DETAIL

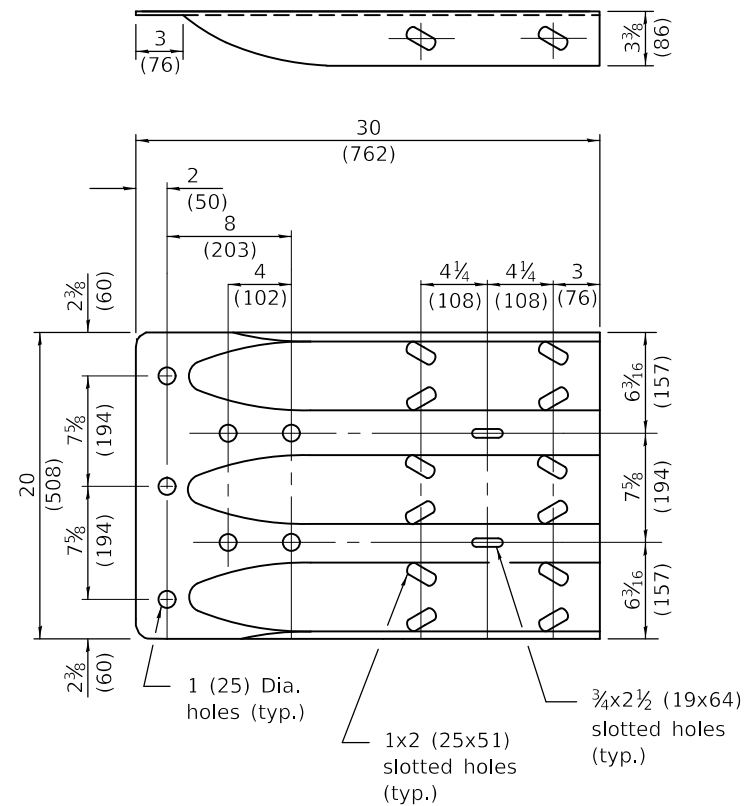

MODIFIED THRIE BEAM END SHOE DETAIL

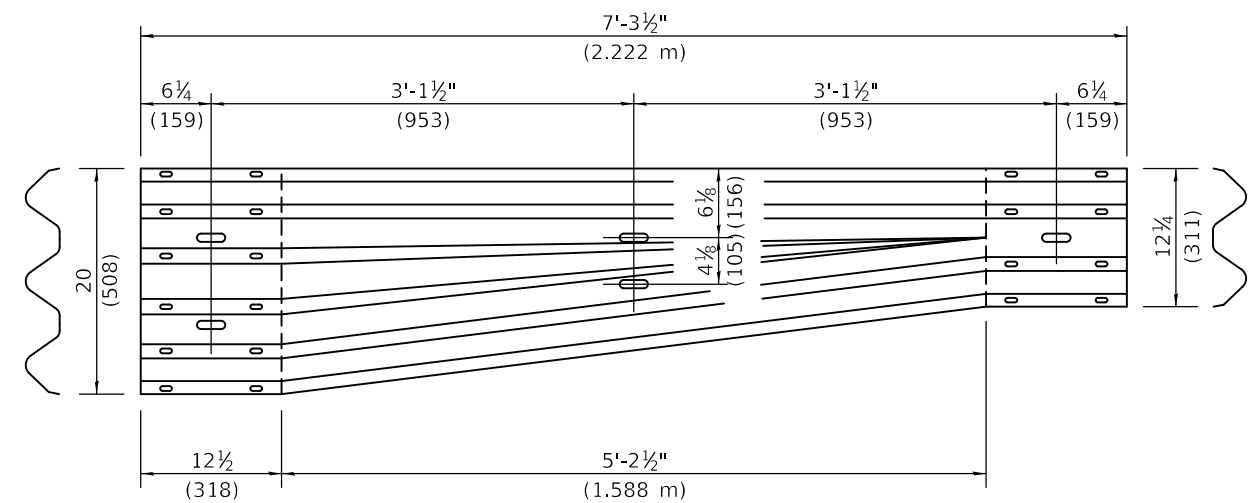

TRANSITION SECTION
(10 gauge (3.4) rail element)

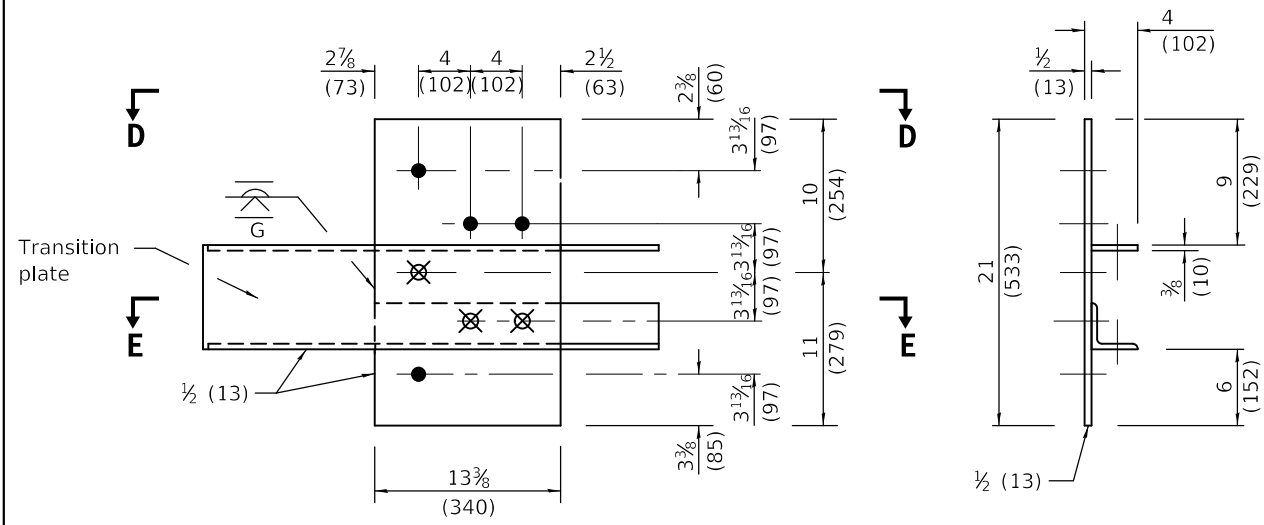

GUARDRAIL CONNECTION PLATE ASSEMBLY DETAILS

(Mirror for opposite end)

- LEGEND**
- 1 (25) dia. hole for $\frac{7}{8}$ (22) dia. H.S. bolt with washer and nut.
 - ⊗ Drill and tap hole for $\frac{7}{8}$ (22) dia. H.S. bolt.

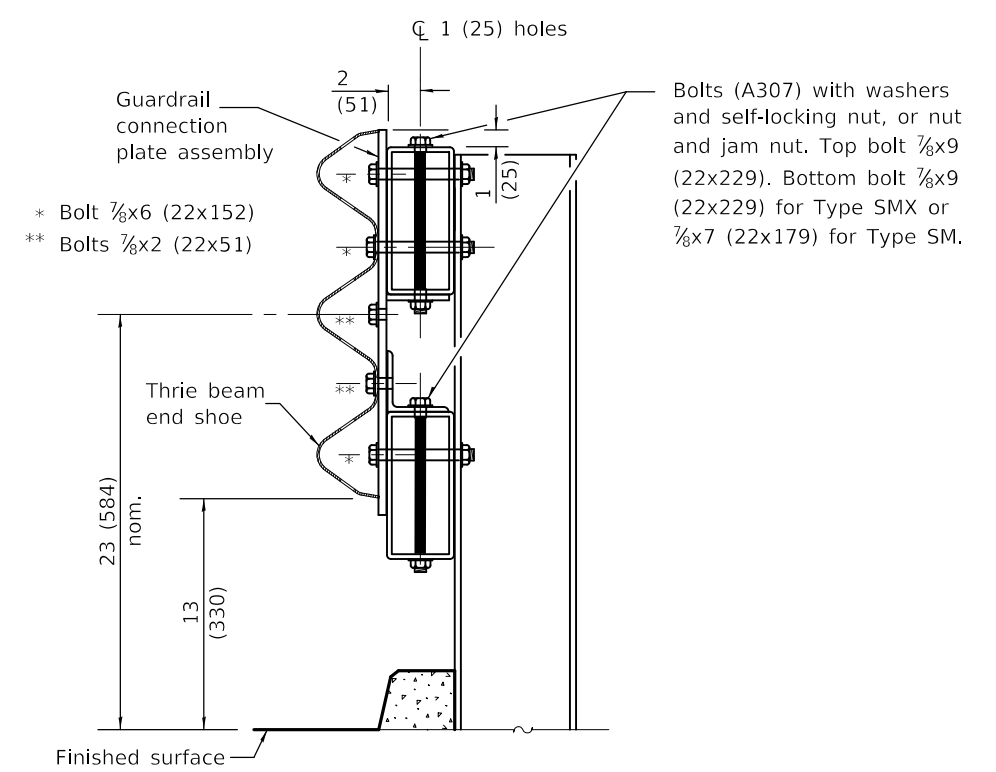

SECTION C-C

Dimensions	A	B	C
For Type SMX Rail	22 (560)	$3\frac{3}{4}$ (95)	$6\frac{1}{16}$ (170)
For Type SM Rail	20 (508)	$1\frac{3}{4}$ (44)	$4\frac{1}{16}$ (119)

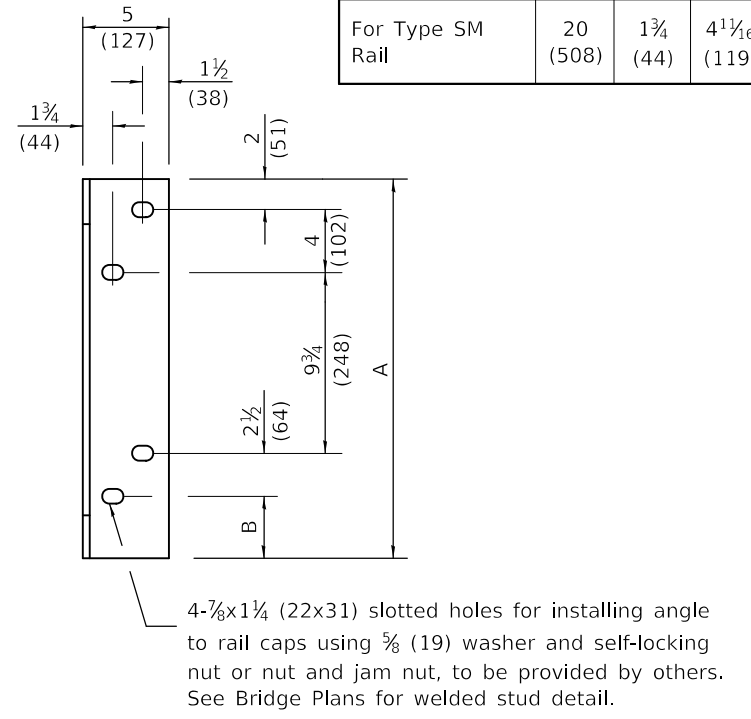
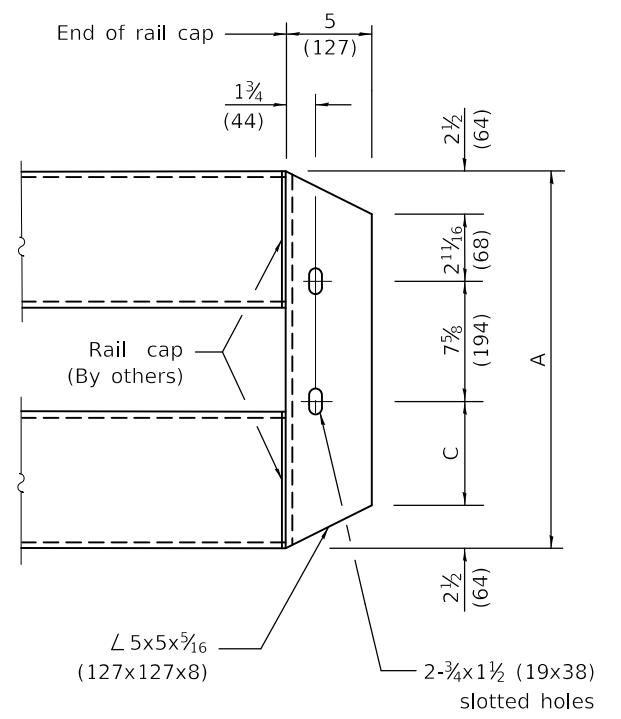
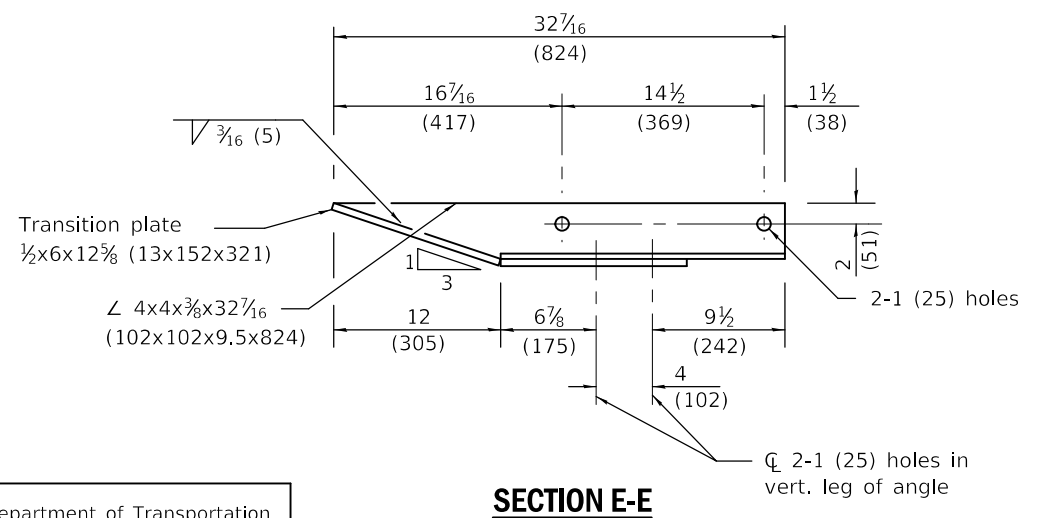
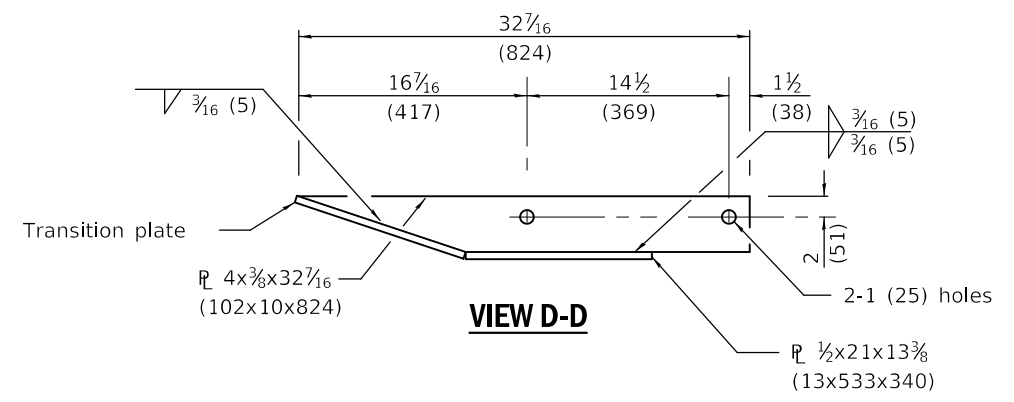

TRAFFIC BARRIER TERMINAL, TYPE 6A

(Sheet 3 of 3)

STANDARD 631032-10

Illinois Department of Transportation

PASSED January 1, 2023

ENGINEER OF SAFETY PROG. & ENGINEERING

APPROVED January 1, 2023

ENGINEER OF DESIGN AND ENVIRONMENT

ISSUED 1-1-2003

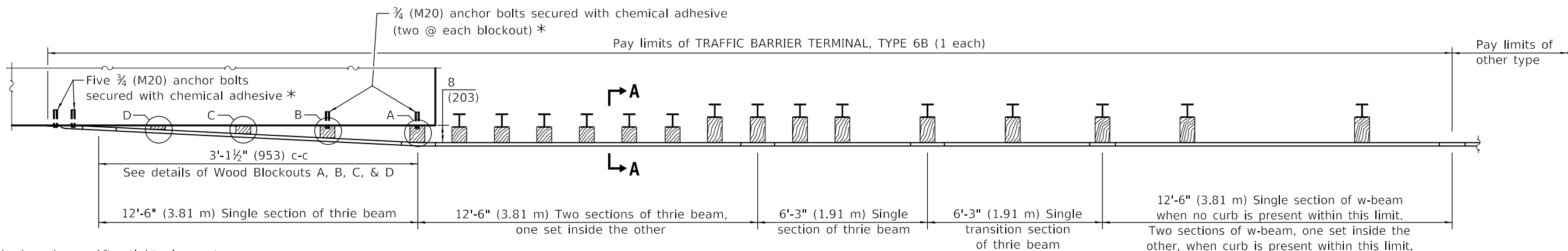

* With standard washers. After tightening, cut the anchor bolts flush with the nuts and damage the nuts to prevent them from loosening.

PLAN

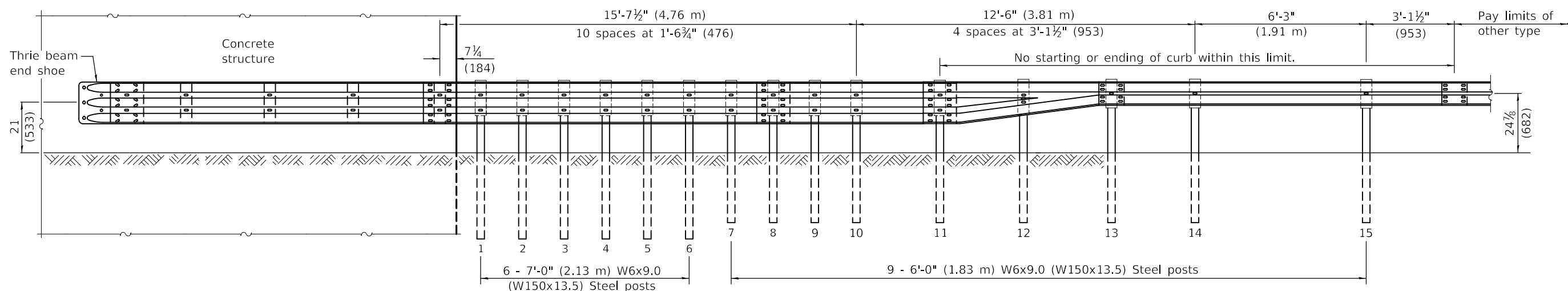

ELEVATION

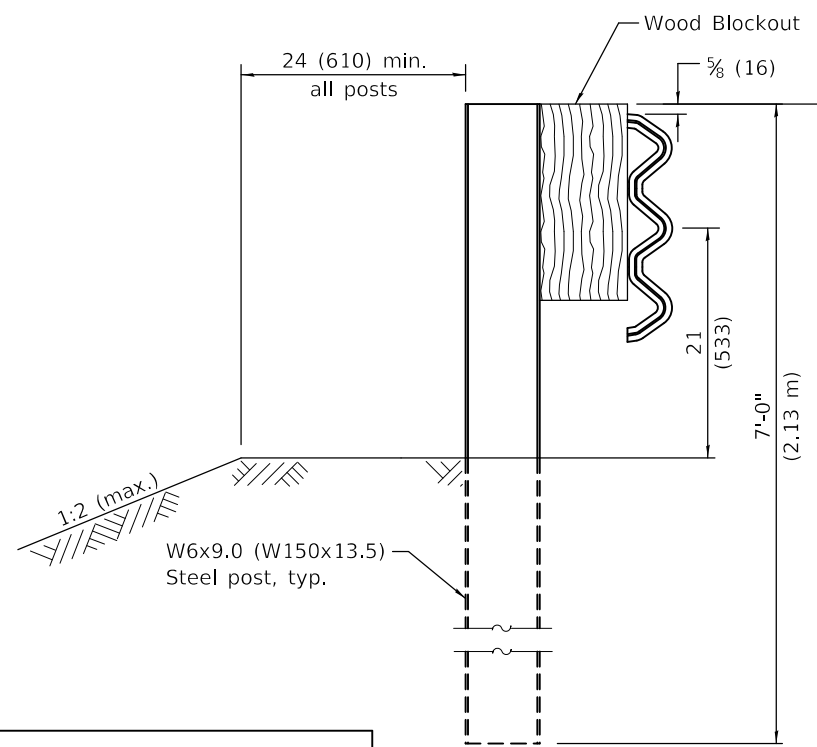

SECTION A-A

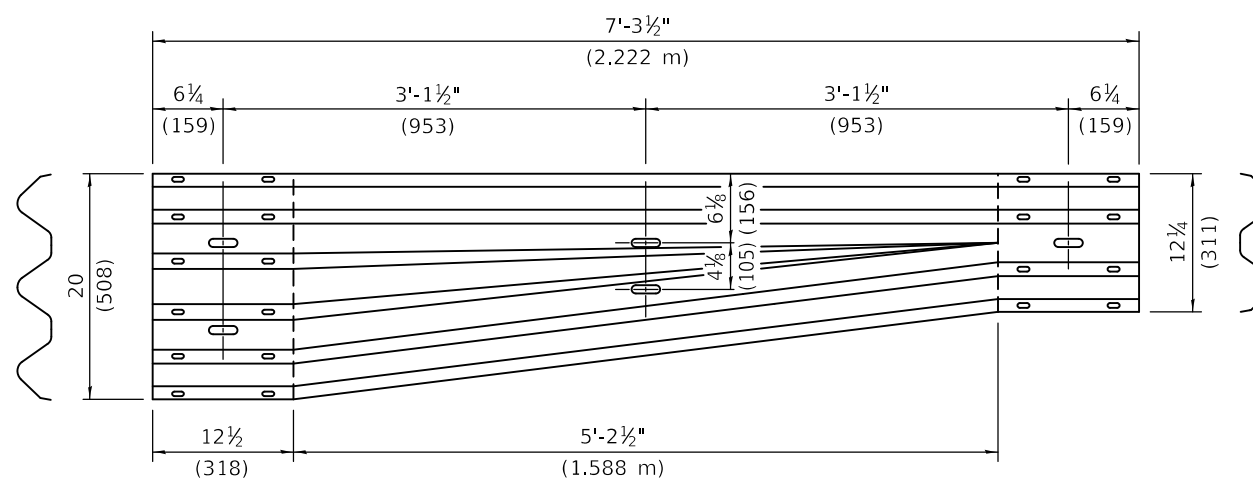

TRANSITION SECTION
(10 gauge (3.4) rail element)

GENERAL NOTES

See Standard 630001 for details of guardrail not shown.

Thrie beam rail shall be bolted to block-out at all posts.

All slope ratios are expressed as units of vertical displacement to units of horizontal displacement (V:H).

All dimensions are in inches (millimeters) unless otherwise shown.

DATE	REVISIONS
1-1-23	Removed two posts and revised blockouts to be consistent with other TBTs.
1-1-20	Added two posts and revised length of posts.

TRAFFIC BARRIER TERMINAL, TYPE 6B

(Sheet 1 of 2)

STANDARD 631033-09

Illinois Department of Transportation

PASSED January 1, 2023

ISSUED 1-1-2003

ENGINEER OF SAFETY PROG. & ENGINEERING

APPROVED January 1, 2023

ENGINEER OF DESIGN AND ENVIRONMENT

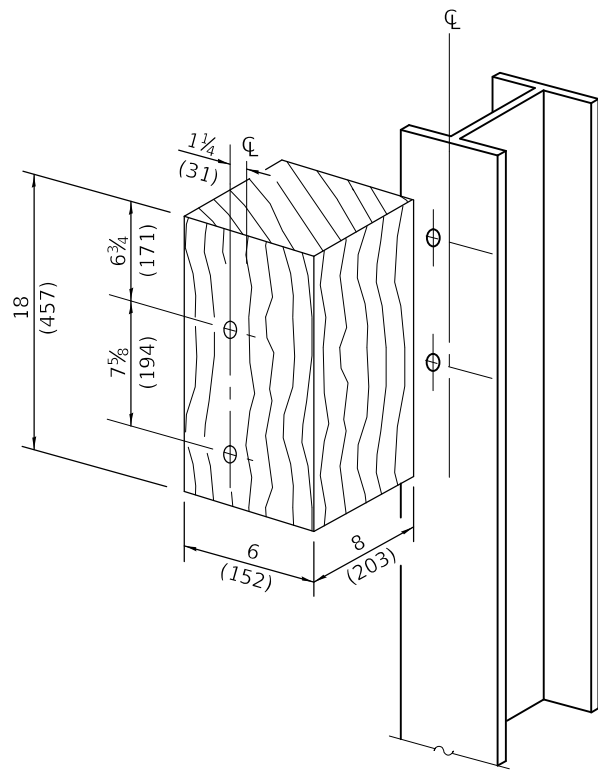

POSTS 1-6 WOOD BLOCKOUT DETAIL

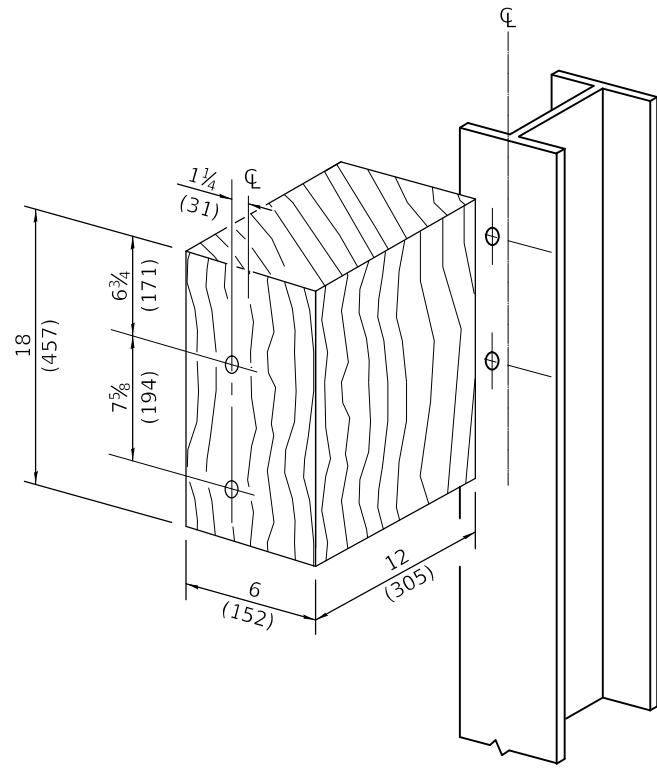

POSTS 7-11 WOOD BLOCKOUT DETAIL

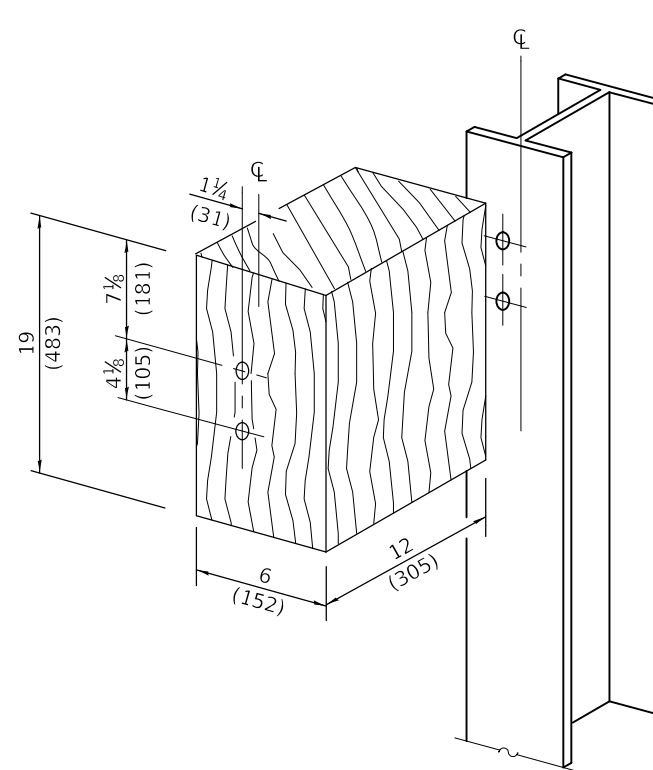

POSTS 12 WOOD BLOCKOUT DETAIL

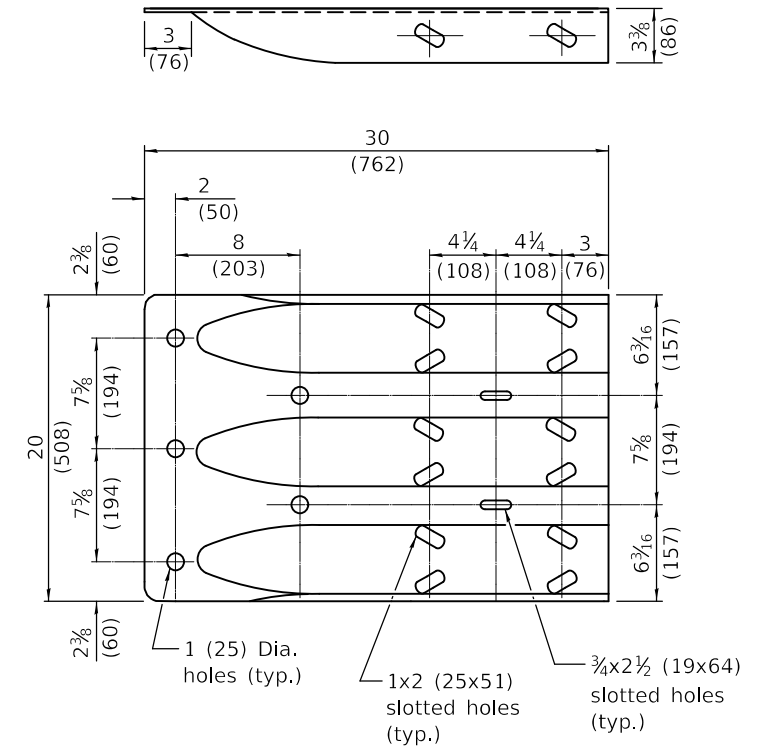

THRIE BEAM END SHOE DETAIL

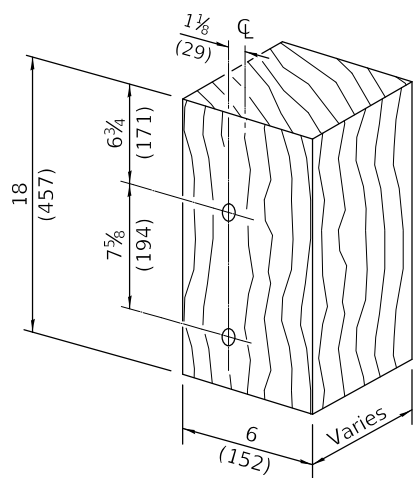

**MODIFIED THICKNESS DETAIL
WOOD BLOCKOUTS A, B, C, & D**

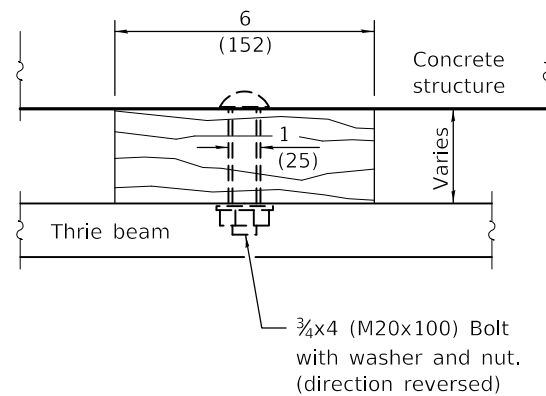

WOOD BLOCKOUT D

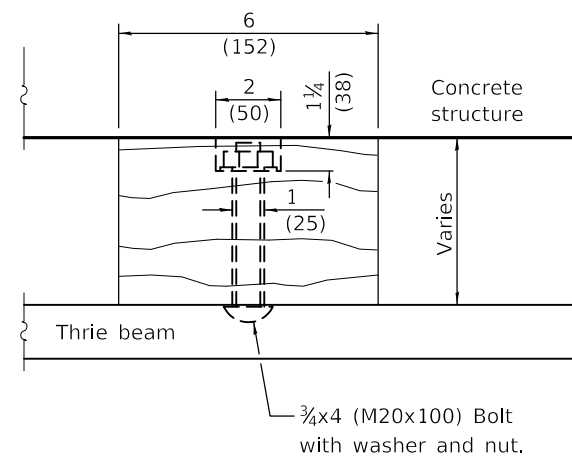

WOOD BLOCKOUT C

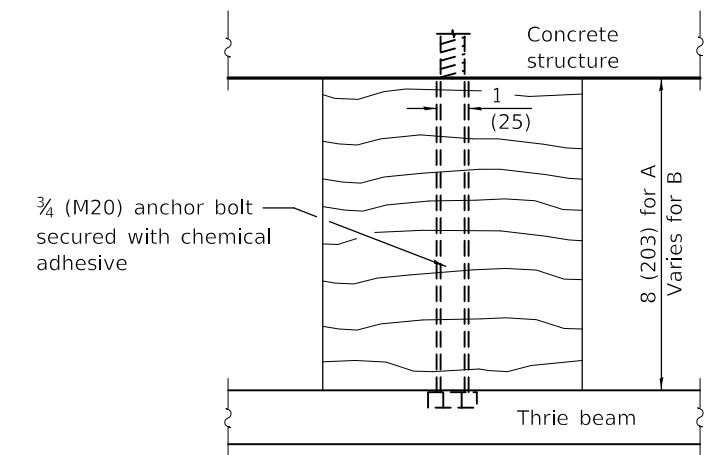

WOOD BLOCKOUT A & B

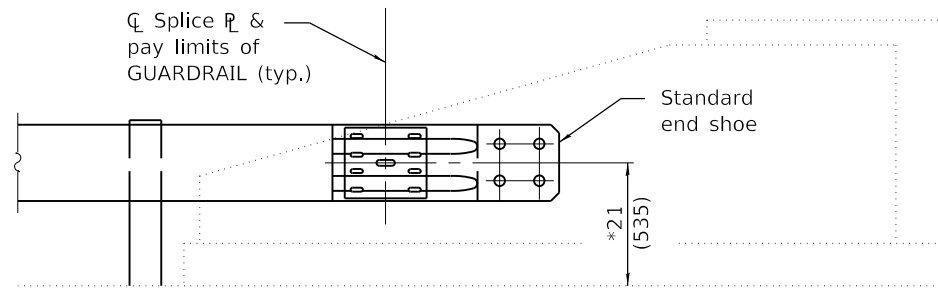

ELEVATION

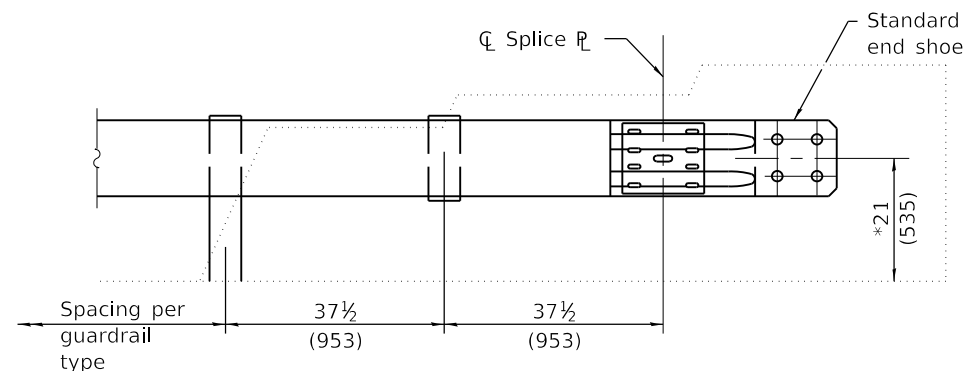

ELEVATION

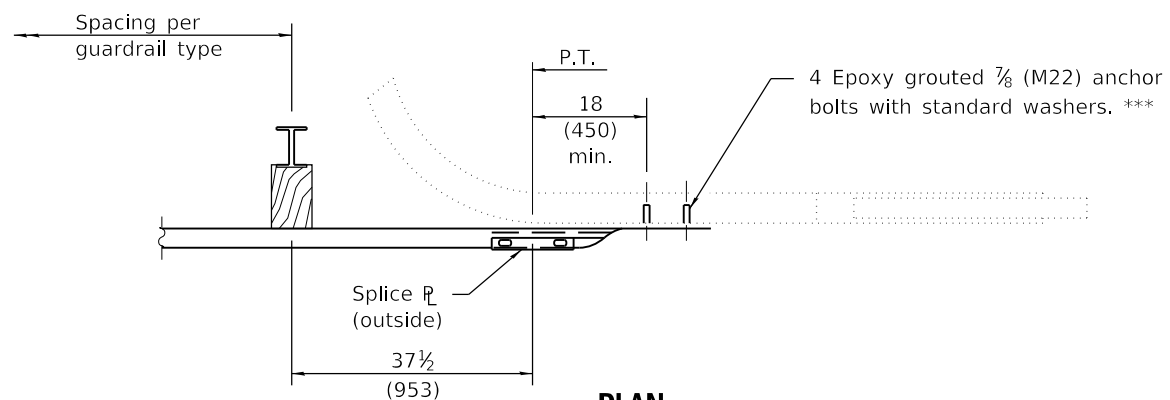

PLAN CURVED WING

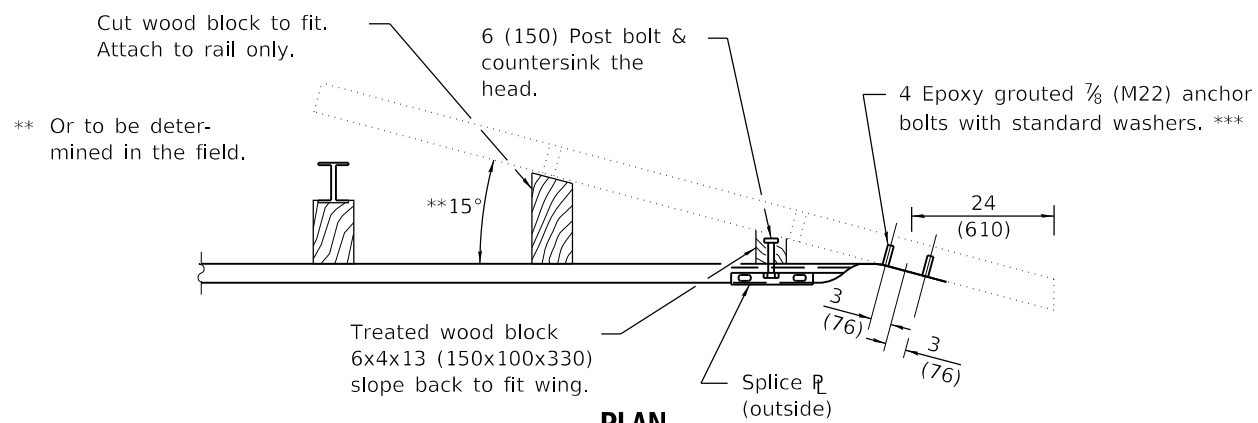

PLAN FLARED WING

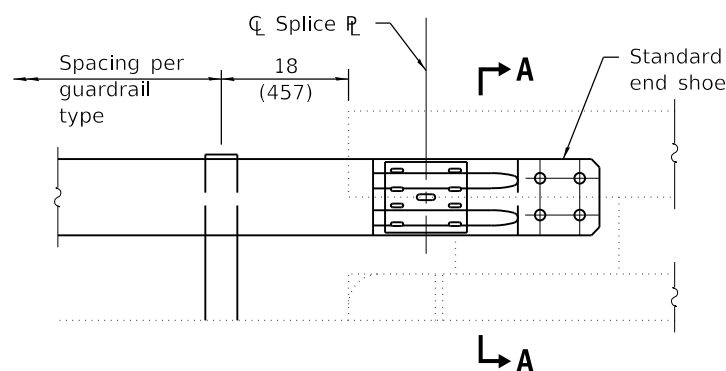

ELEVATION

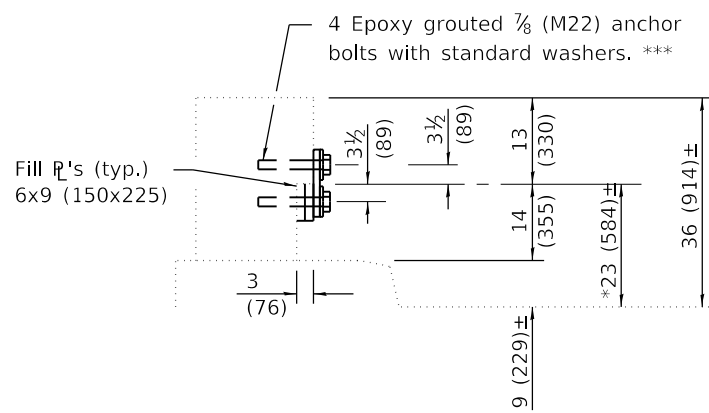

SECTION A-A (HIGH RAIL)

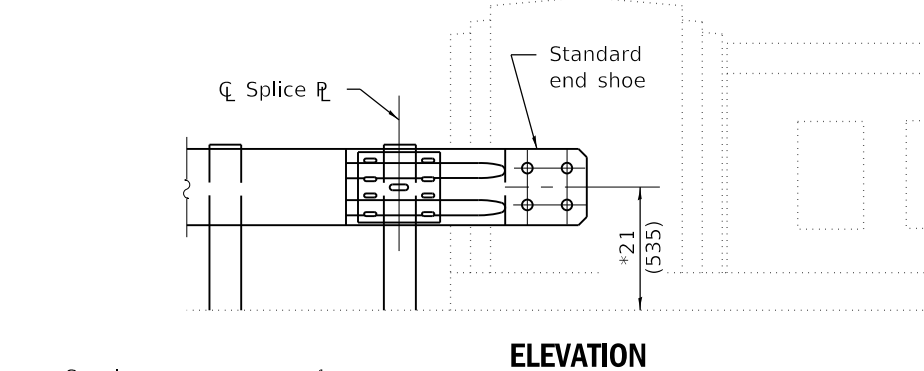

ELEVATION

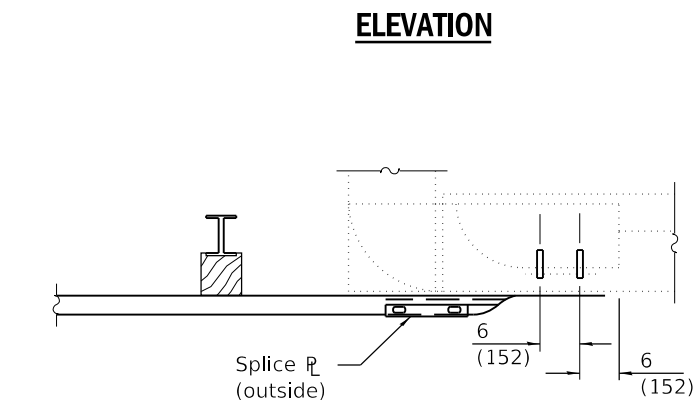

PLAN

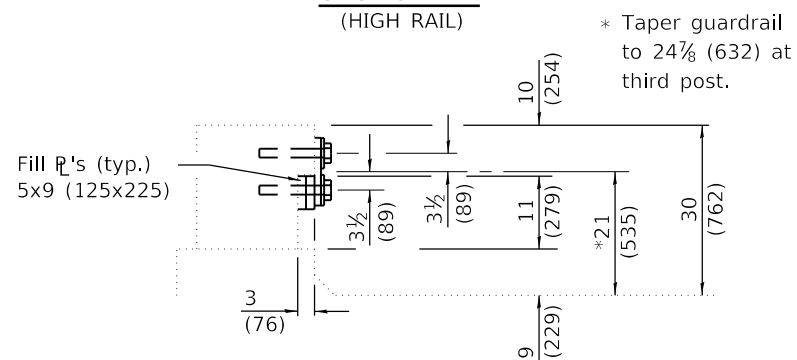

SECTION A-A (LOW RAIL)

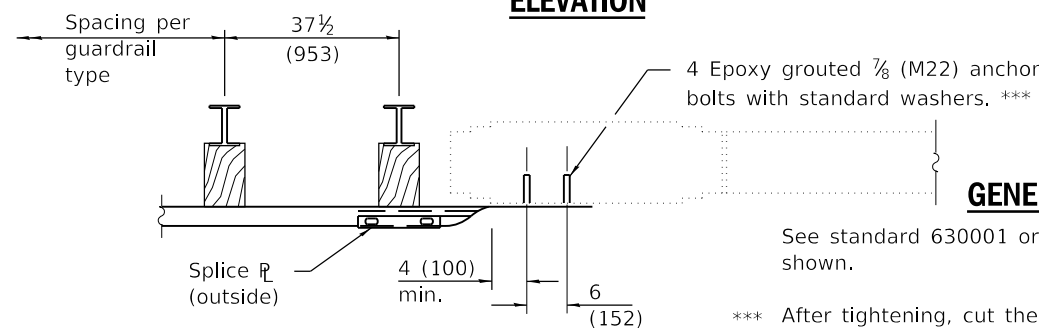

PLAN CONCRETE HANDRAIL

GENERAL NOTES

See standard 630001 or details of guardrail not shown.

*** After tightening, cut the anchor bolts flush with nuts, and damage the bolt head to prevent it from loosening.

All dimensions are in inches (millimeters) unless otherwise shown.

DATE	REVISIONS
1-1-09	Switched units to English (metric).
1-1-07	Changes adopted to implement the Midwest Guardrail System.

TRAFFIC BARRIER TERMINAL, TYPE 10

STANDARD 631046-04

Illinois Department of Transportation

PASSED January 1, 2009

ENGINEER OF POLICY AND PROCEDURES

APPROVED January 1, 2009

ENGINEER OF DESIGN AND ENVIRONMENT

ISSUED 1-1-97

REINFORCED CONCRETE HANDRAIL

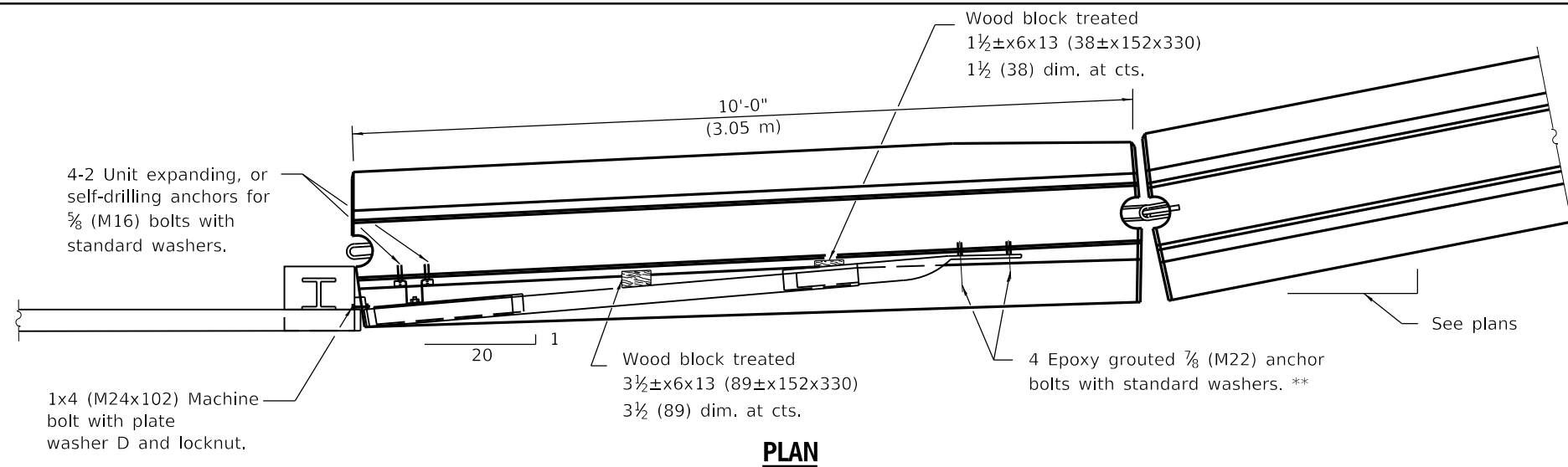

PLAN

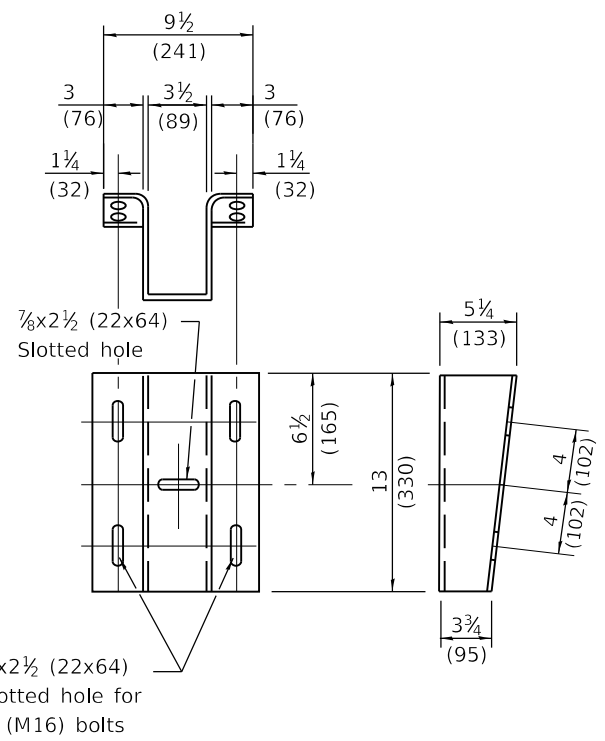

BRACKET U

(¼ (6) Thick steel plate or rectangular tubing with flange welded on.)

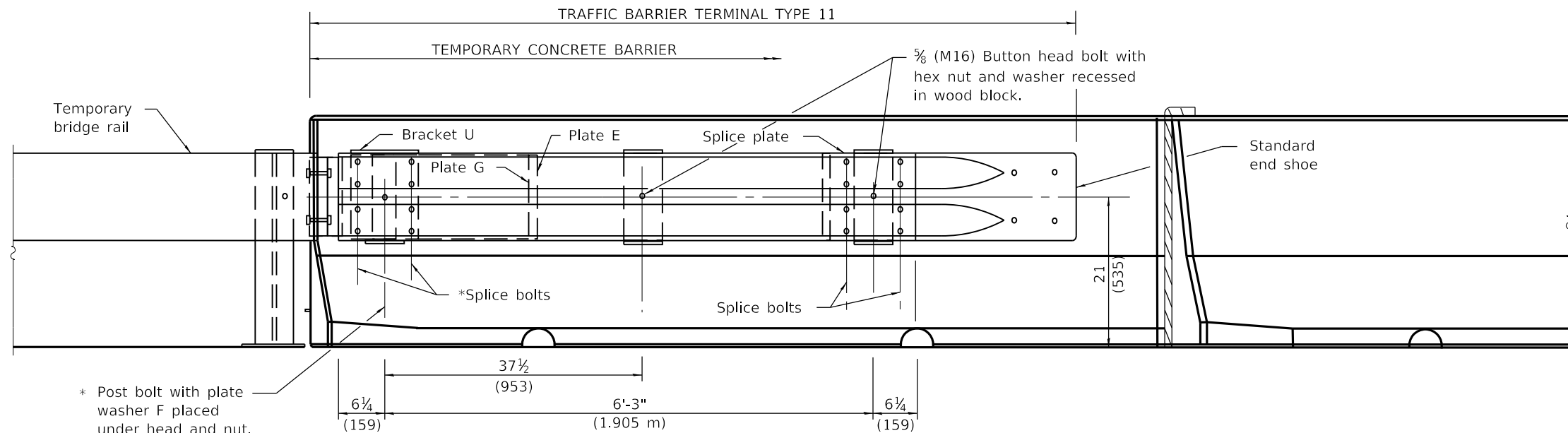

ELEVATION

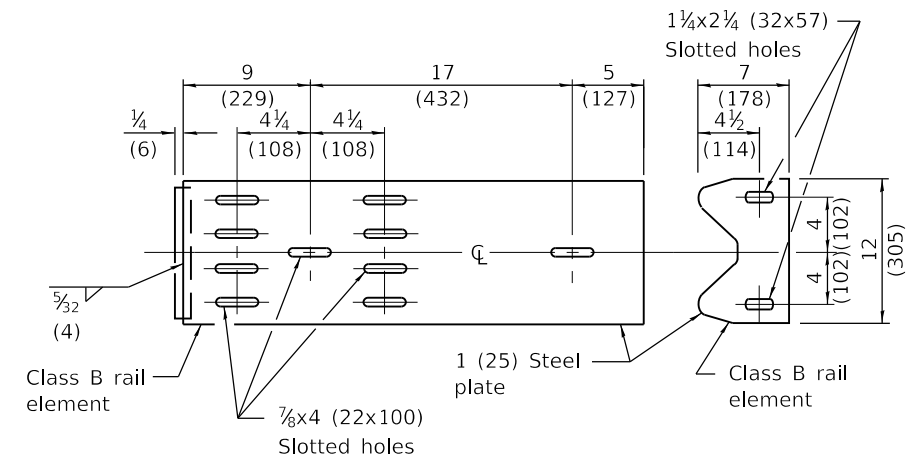

PLATE G

(Place between the rail element and Plate E)

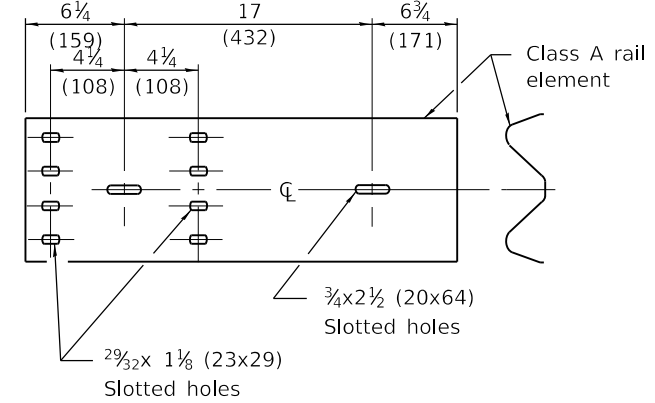

PLATE E

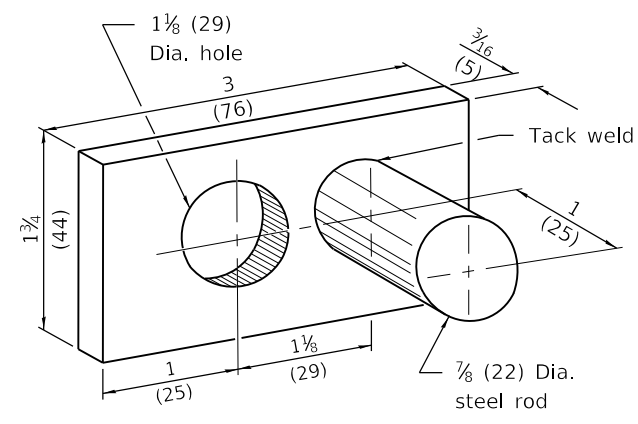

PLATE WASHER D

GENERAL NOTES

For details of guardrail not shown, see Standard 630001.

Install the face of the guardrail flush with the face of the temporary bridge rail. Install plate washer D so that the 1 (25) projection fills the remainder of the slotted holes in the 1 (25) end plate on plate G after the 1 (M24) diameter bolts are in place.

* Bolts shall be provided with a lock nut or double nut and shall be tightened only to a point that will allow plate G to be free to move.

** After tightening, cut the anchor bolts flush with nuts, and damage the bolt head to prevent them from loosening.

All dimensions are in inches (millimeters) unless otherwise shown.

Illinois Department of Transportation

PASSED January 1, 2011

Michael Beard
ENGINEER OF POLICY AND PROCEDURES

APPROVED January 1, 2011

ENGINEER OF DESIGN AND ENVIRONMENT

ISSUED 1-1-97

DATE	REVISIONS
1-1-11	Corrected weld symbol on PLATE G detail.
1-1-09	Switched units to English (metric).

TRAFFIC BARRIER TERMINAL TYPE 11

STANDARD 631051-03

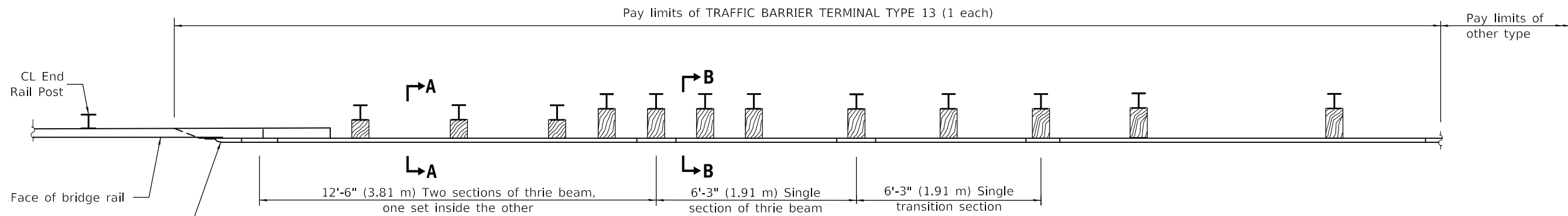

PLAN

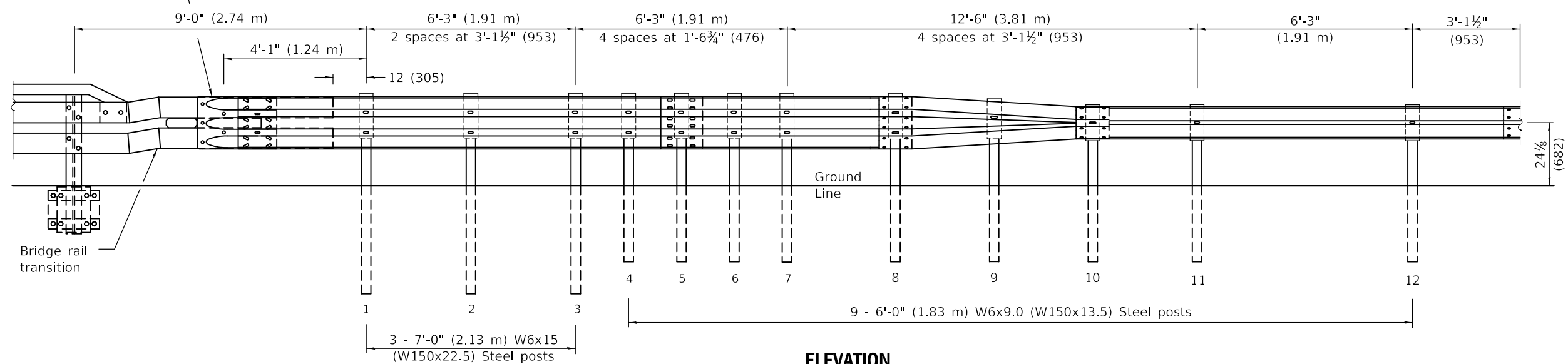

ELEVATION

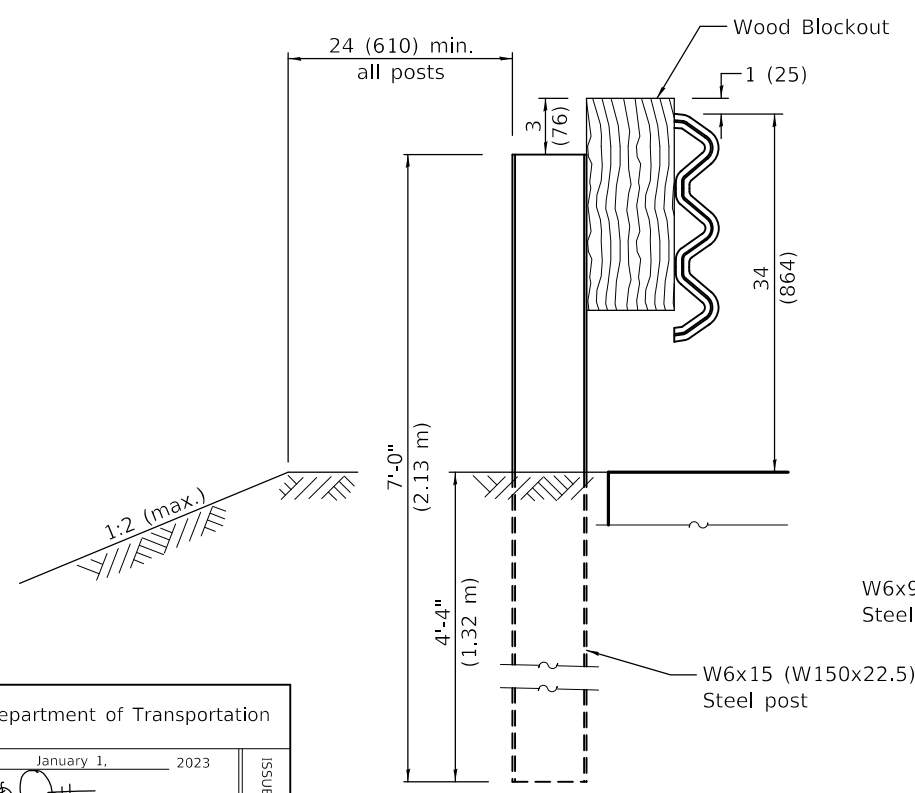

SECTION A-A
Posts 1-3

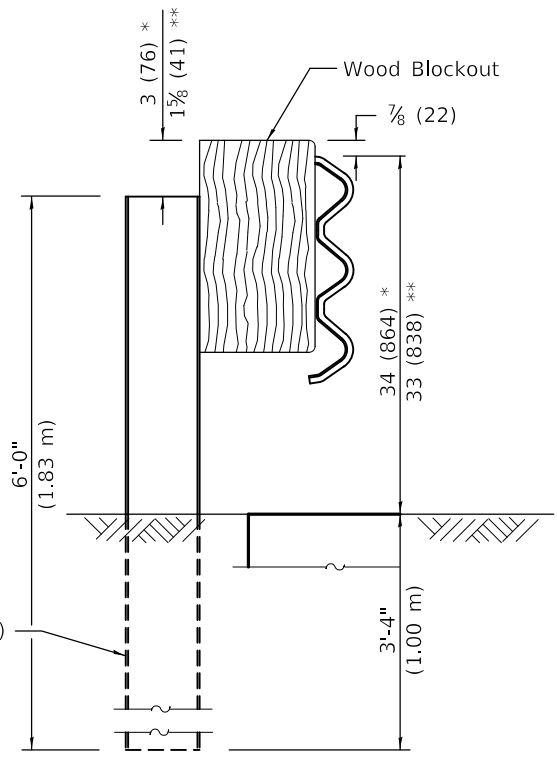

SECTION B-B

* Posts 4-8
** Post 9

GENERAL NOTES

This standard shows attachment to side mounted bridge railing, Type IL-OH.
See Standard 630001 for details of guardrail not shown.
Thrie beam rail shall be bolted to block-out at all posts.
All slope ratios are expressed as units of vertical displacement to units of horizontal displacement (V:H).
All dimensions are in inches (millimeters) unless otherwise shown.

DATE	REVISIONS
1-1-23	Revised pay limits to end at splice.
1-1-22	New Standard

TRAFFIC BARRIER TERMINAL, TYPE 13

(Sheet 1 of 3)

STANDARD 631061-01

Illinois Department of Transportation

PASSED January 1, 2023

ENGINEER OF SAFETY PROG. & ENGINEERING

APPROVED January 1, 2023

ENGINEER OF DESIGN AND ENVIRONMENT

ISSUED 1-1-2022

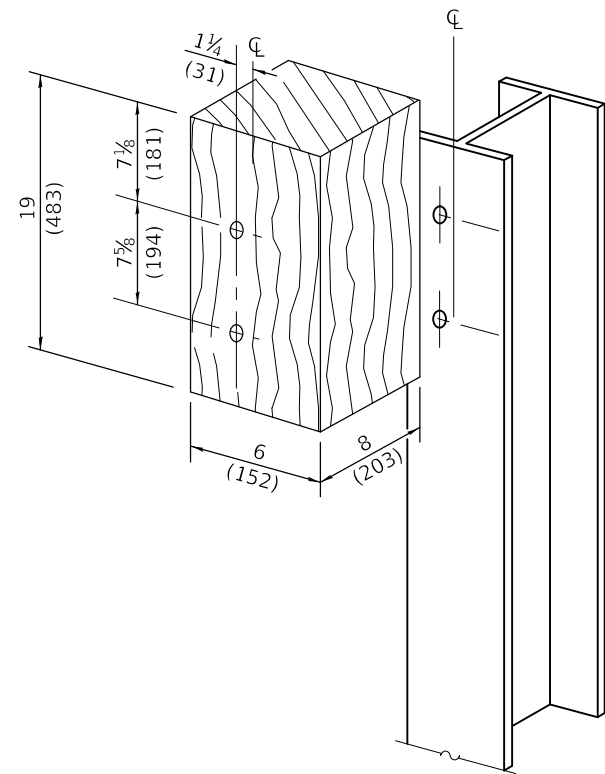

POSTS 1-3 WOOD BLOCKOUT DETAIL

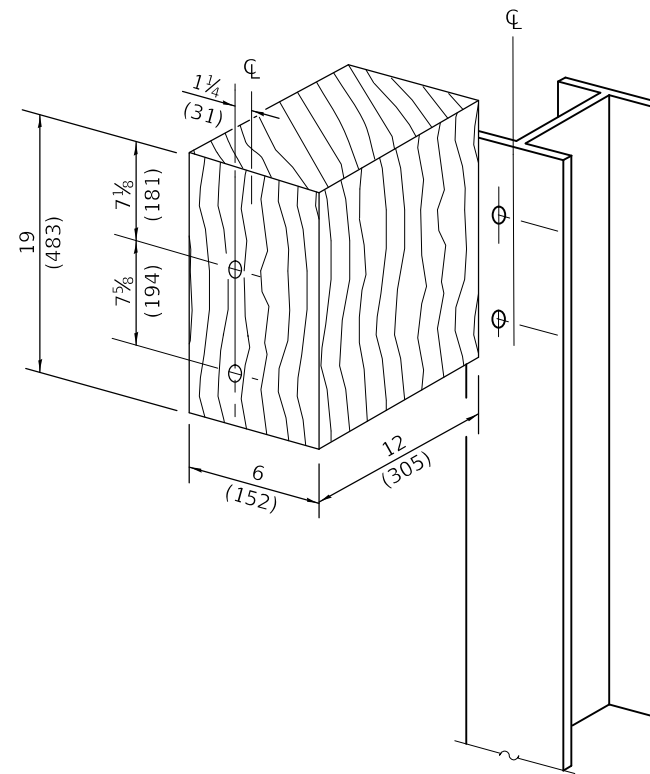

POSTS 4-8 WOOD BLOCKOUT DETAIL

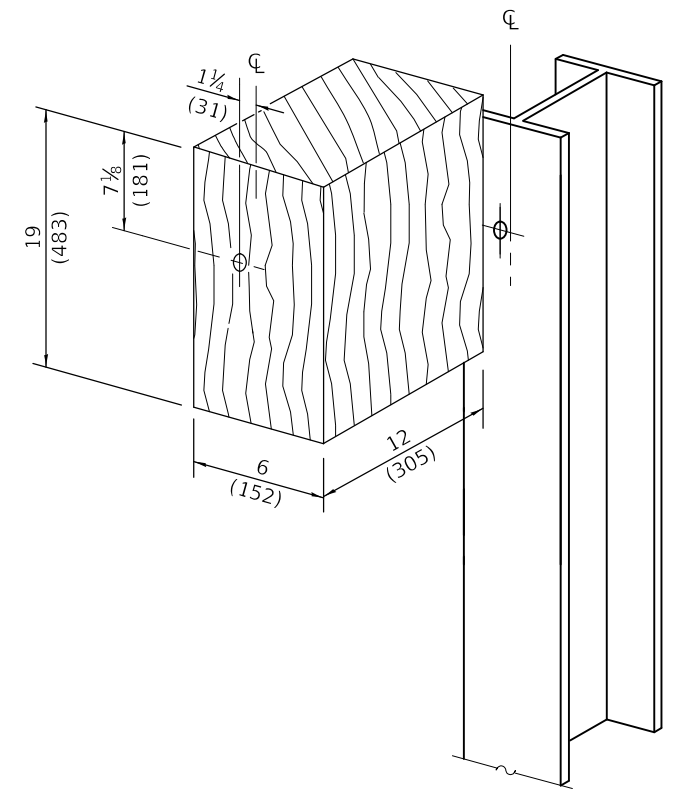

POST 9 WOOD BLOCKOUT DETAIL

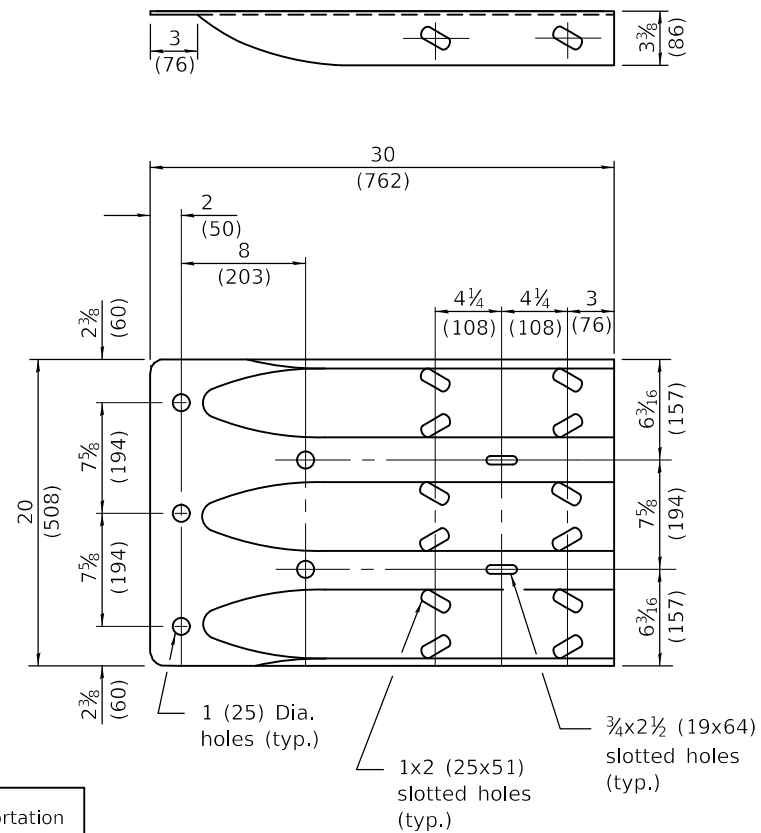

THRIE BEAM END SHOE DETAIL

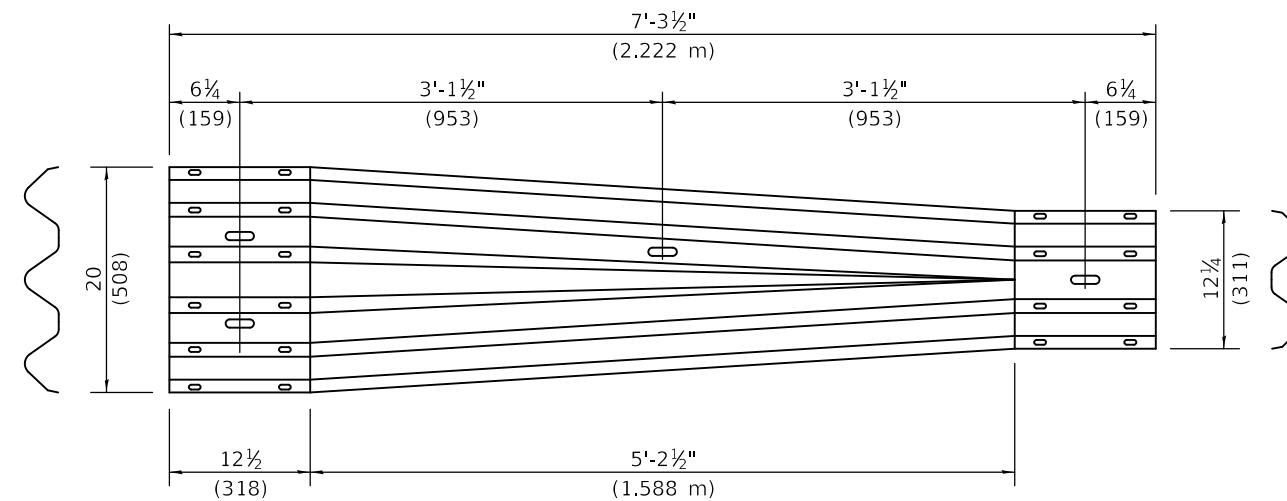

TRANSITION SECTION
(10 gauge (3.4) rail element)

**TRAFFIC BARRIER
TERMINAL, TYPE 13**

(Sheet 2 of 3)

STANDARD 631061-01

Illinois Department of Transportation

PASSED January 1, 2023

ENGINEER OF SAFETY PROG. & ENGINEERING

APPROVED January 1, 2023

ENGINEER OF DESIGN AND ENVIRONMENT

ISSUED 1-1-2022

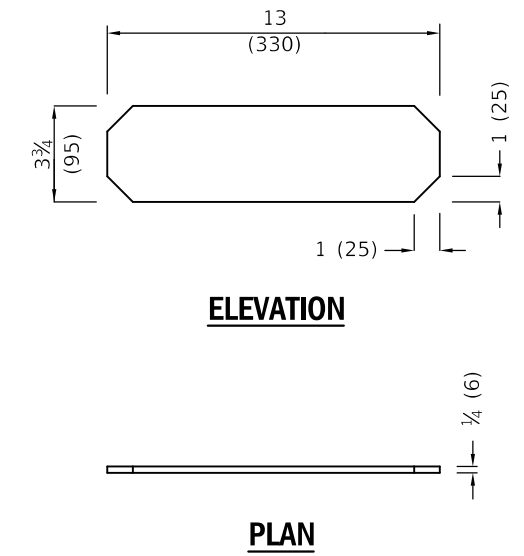
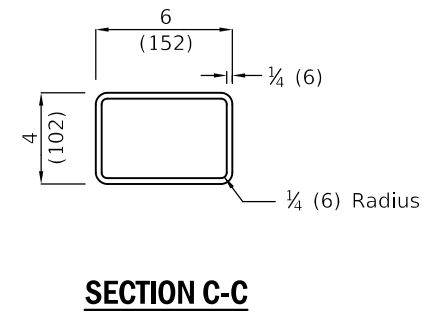
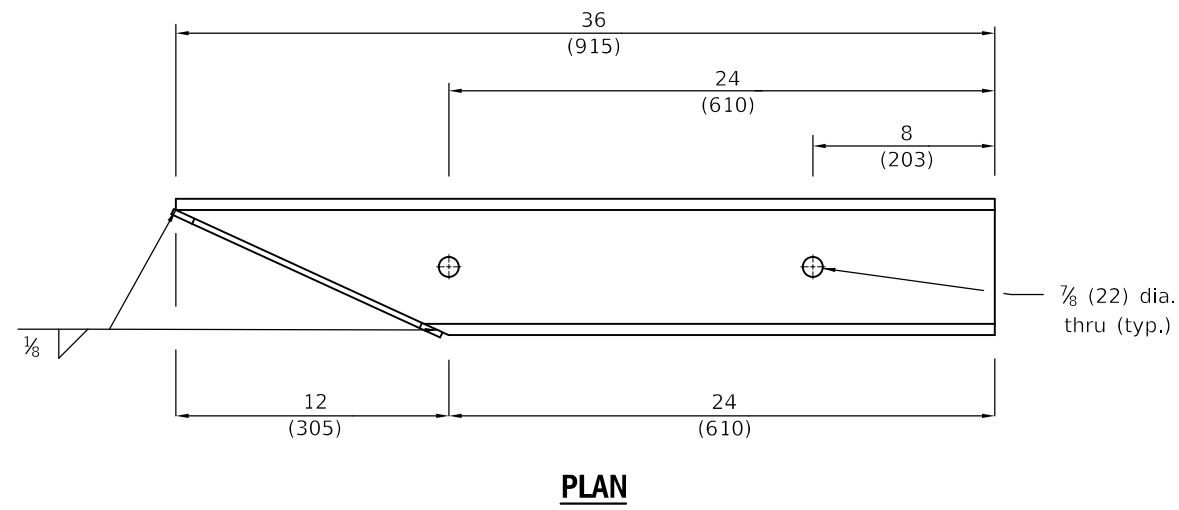

ANGLE CUT TUBE ASSEMBLY - END PLATE

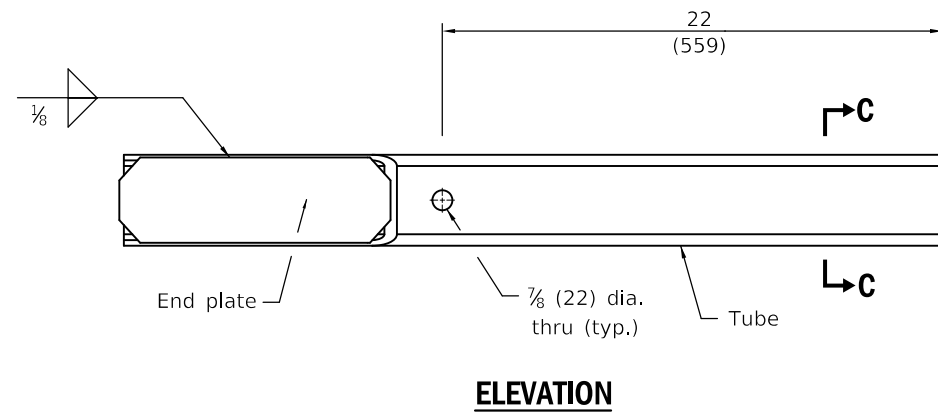

ANGLE CUT TUBE ASSEMBLY

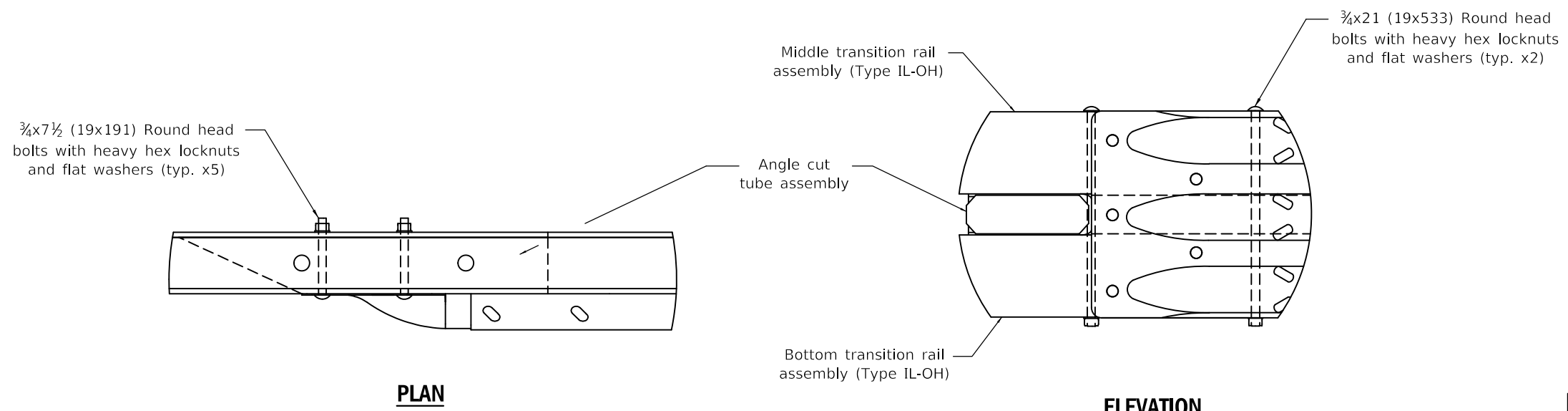

BRIDGE RAIL CONNECTION DETAIL

Illinois Department of Transportation

PASSED January 1, 2023

ENGINEER OF SAFETY PROG. & ENGINEERING

APPROVED January 1, 2023

ENGINEER OF DESIGN AND ENVIRONMENT

ISSUED 1-1-2022

**TRAFFIC BARRIER
TERMINAL, TYPE 13**

(Sheet 3 of 3)

STANDARD 631061-01

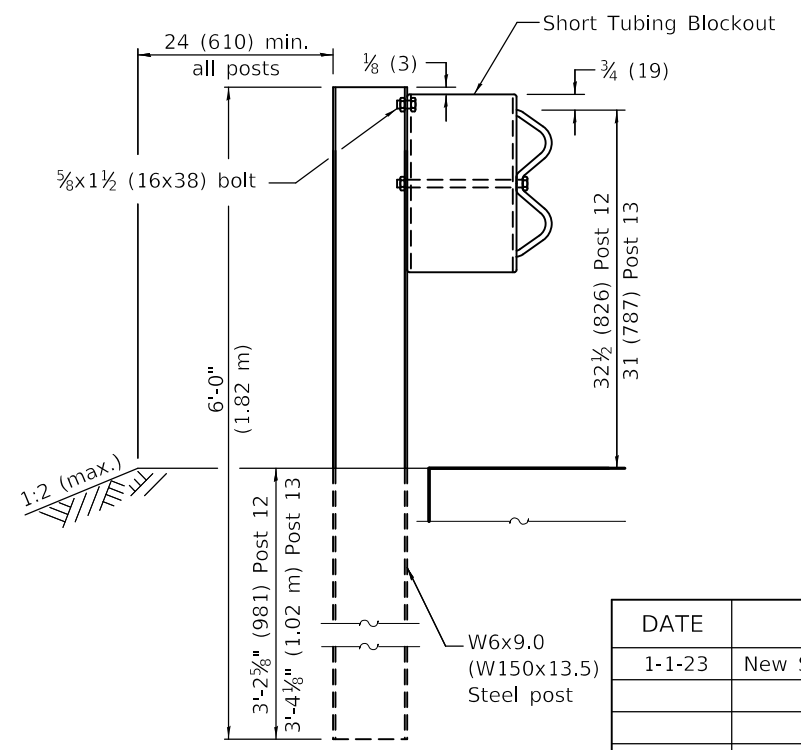
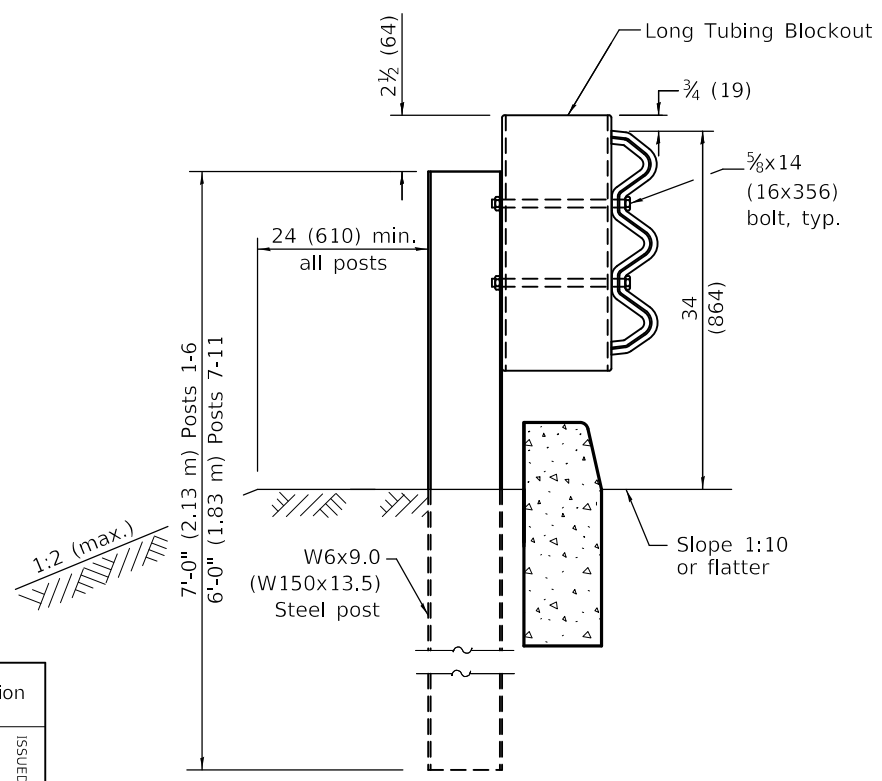
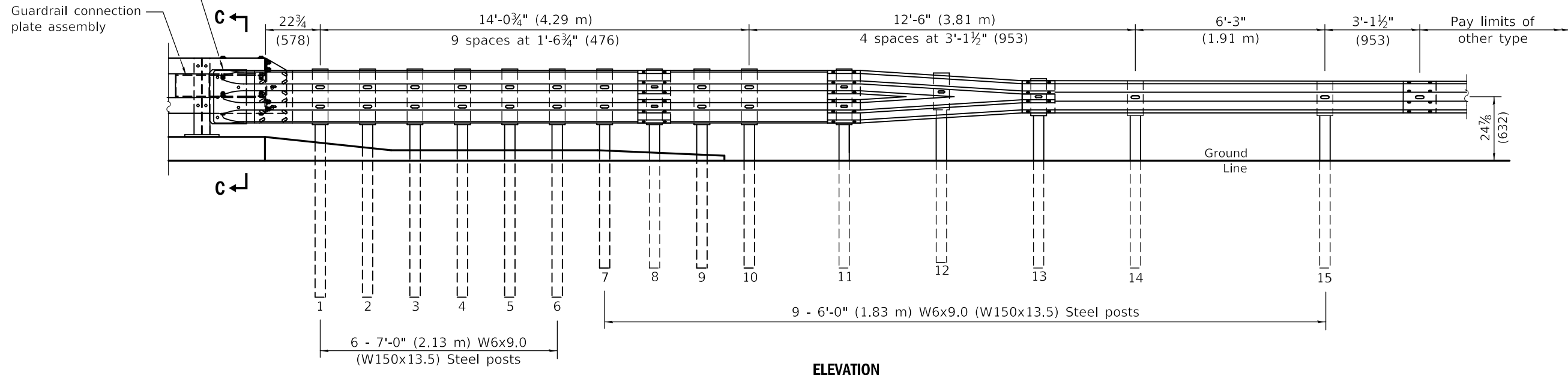
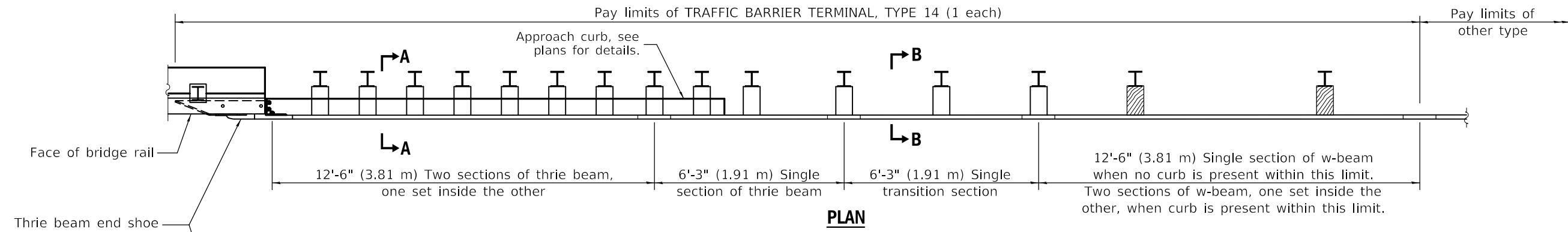

GENERAL NOTES

This standard shows attachment to curb mounted bridge rail, Type CO-10.

See Standard 630001 for details of guardrail not shown.

Blockouts for posts 1-13 shall be HSS 12x6x1/4 (305x150x6) or solid wood of the same dimensions.

Thrie beam rail shall be bolted to block-out at all posts.

All slope ratios are expressed as units of vertical displacement to units of horizontal displacement (V:H).

All dimensions are in inches (millimeters) unless otherwise shown.

DATE	REVISIONS
1-1-23	New Standard.

**TRAFFIC BARRIER
TERMINAL, TYPE 14**

(Sheet 1 of 3)

STANDARD 631066

Illinois Department of Transportation

PASSED January 1, 2023

ENGINEER OF SAFETY PROG. AND ENGINEERING

APPROVED January 1, 2023

ENGINEER OF DESIGN AND ENVIRONMENT

ISSUED 1-1-2023

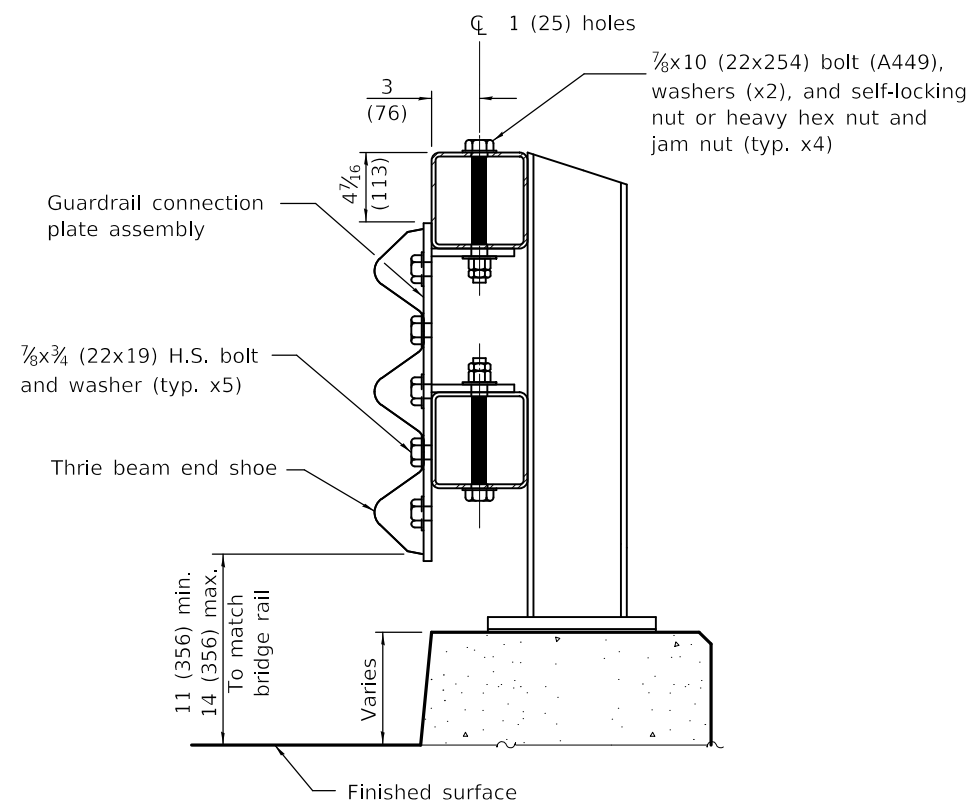

SECTION C-C

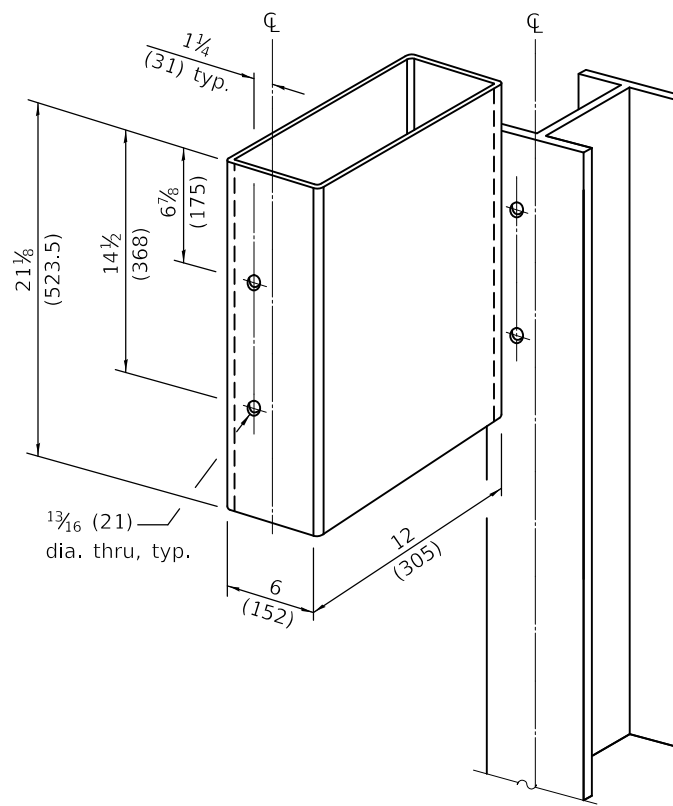

LONG TUBING BLOCKOUT DETAIL

Posts 1-11

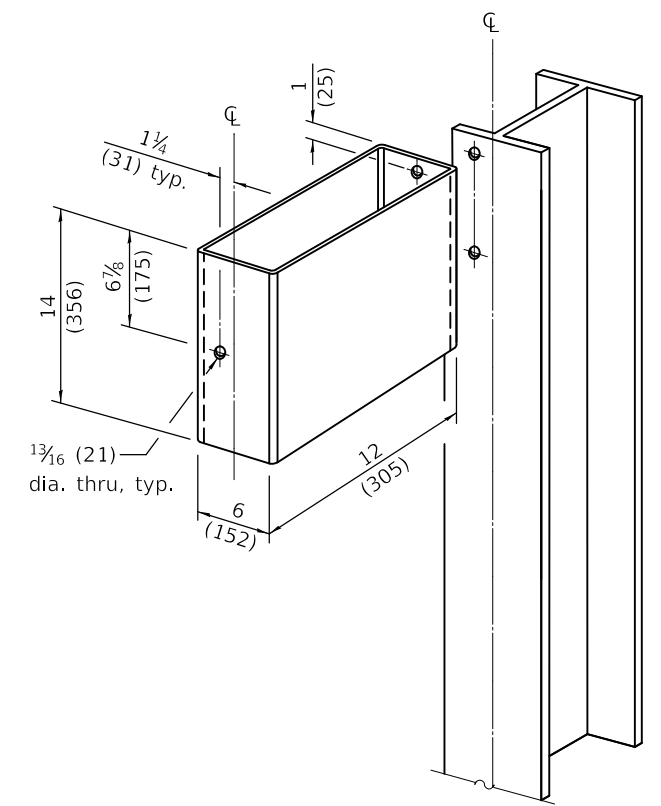

SHORT TUBING BLOCKOUT DETAIL

Posts 12-13

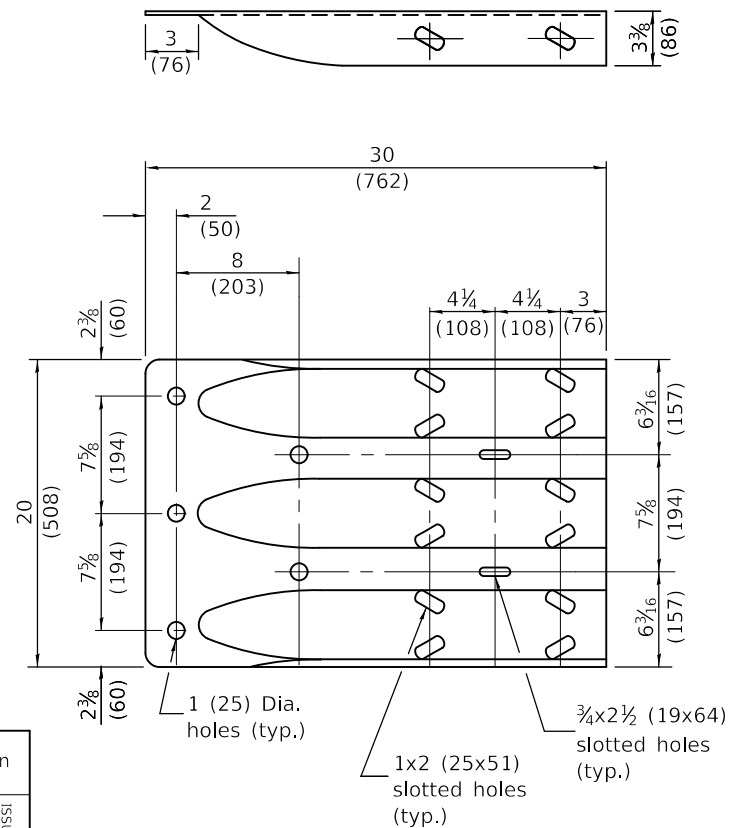

THRIE BEAM END SHOE DETAIL

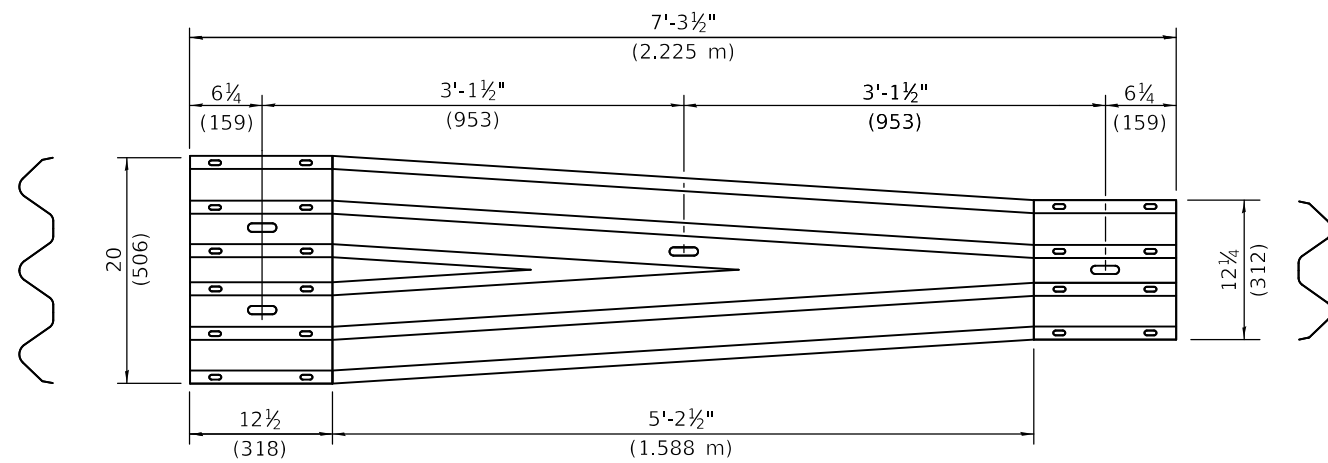

TRANSITION SECTION
(10 gauge (3.4) rail element)

**TRAFFIC BARRIER
TERMINAL, TYPE 14**

(Sheet 2 of 3)

STANDARD 631066

Illinois Department of Transportation

PASSED January 1, 2023

ISSUED 1-1-2023

ENGINEER OF SAFETY PROG. AND ENGINEERING

APPROVED January 1, 2023

ENGINEER OF DESIGN AND ENVIRONMENT

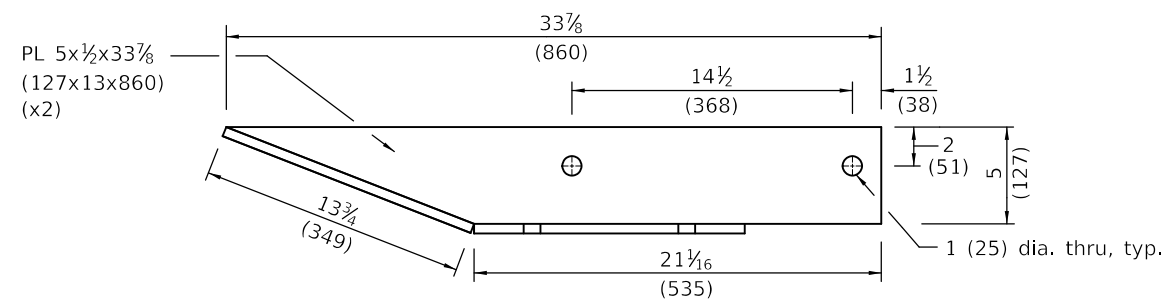

PLAN

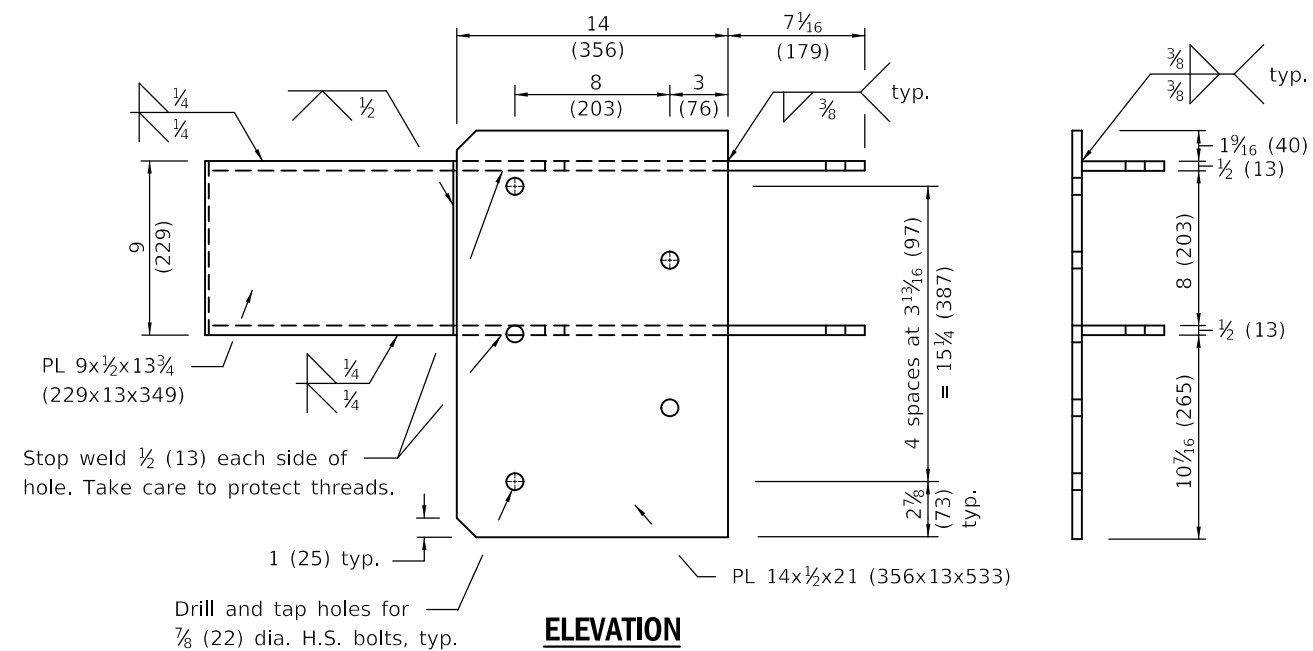

ELEVATION

GUARDRAIL CONNECTION PLATE ASSEMBLY DETAIL

Front View (Mirror for opposite end)

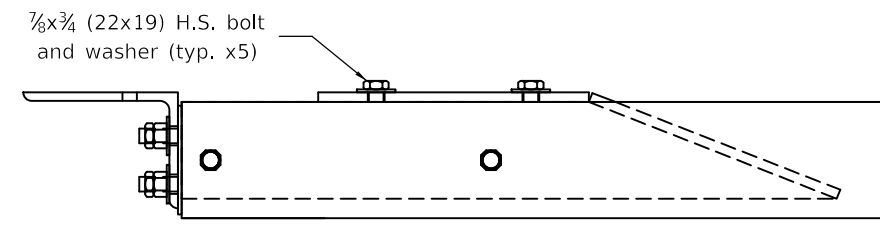

PLAN

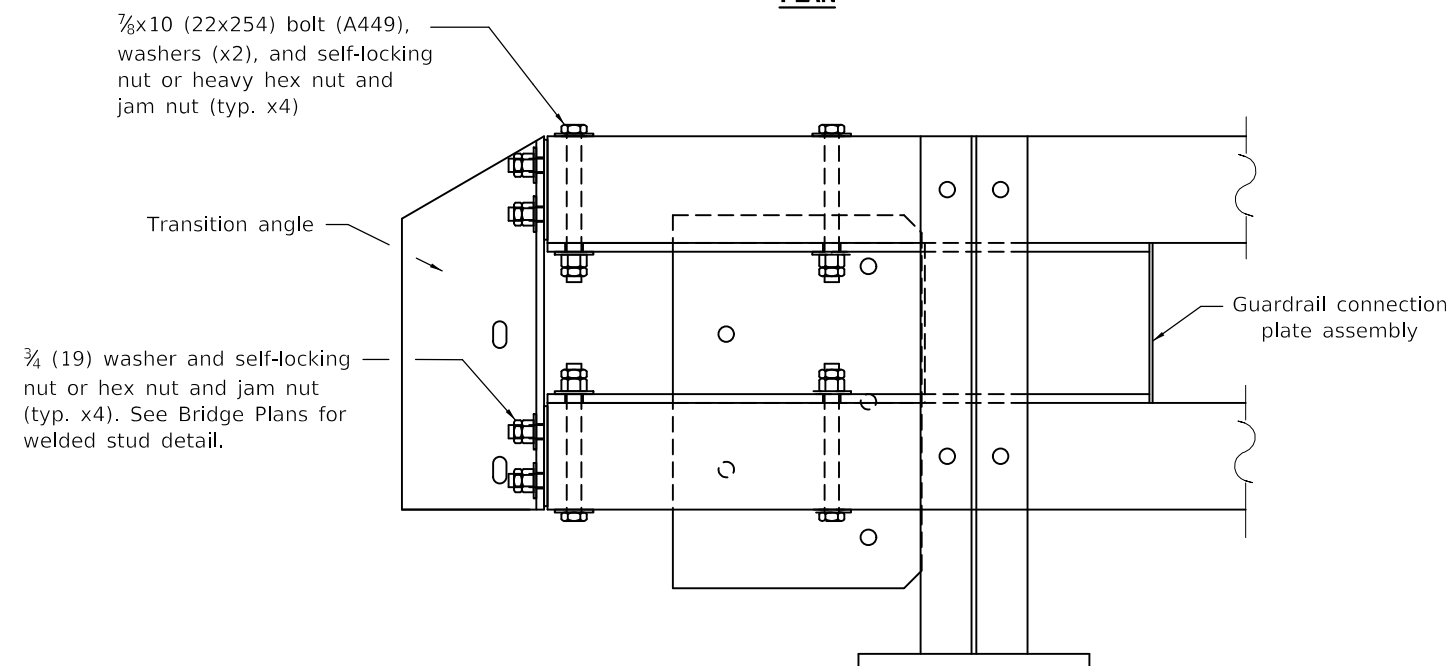

ELEVATION

BRIDGE RAIL CONNECTION DETAIL

Back View (Thrie beam end shoe not shown for clarity)

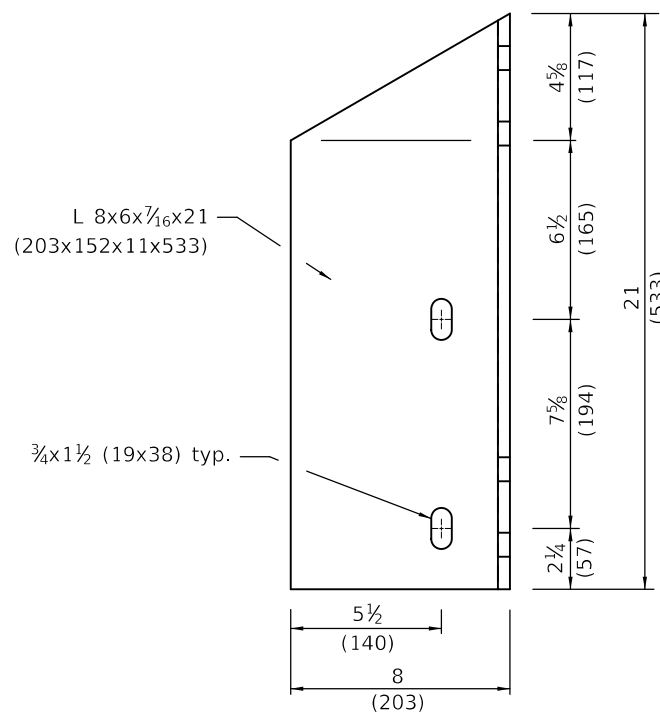

TRANSITION ANGLE

(Mirror for opposite end)

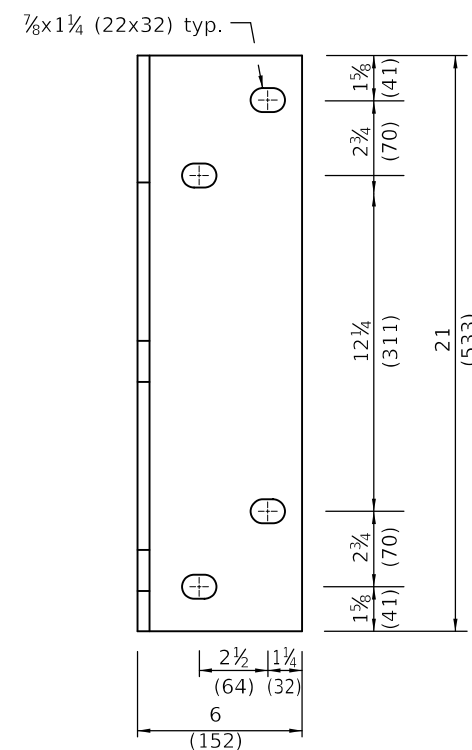

Illinois Department of Transportation

PASSED January 1, 2023

ENGINEER OF SAFETY PROG. AND ENGINEERING

APPROVED January 1, 2023

ENGINEER OF DESIGN AND ENVIRONMENT

ISSUED 1-1-2023

**TRAFFIC BARRIER
TERMINAL, TYPE 14**

(Sheet 3 of 3)

STANDARD 631066

**SPACING FOR DELINEATORS
ON HORIZONTAL CURVES**

Radius of Curve Feet (m)	Spacing on Curve Feet (m)	Spacing in Advance and Beyond Curve Feet (m)		
		1st. Space	2nd. Space	3rd. Space
Less than 100 (30)	20 (5)	40 (10)	65 (20)	125 (40)
100 - 174 (30 - 54)	30 (10)	60 (20)	90 (25)	180 (55)
175 - 224 (55 - 69)	35 (10)	70 (20)	110 (35)	200 (60)
225 - 274 (70 - 84)	40 (10)	85 (25)	125 (40)	200 (60)
275 - 349 (85 - 104)	50 (15)	95 (30)	145 (45)	200 (60)
350 - 449 (105 - 134)	55 (15)	110 (35)	170 (50)	200 (60)
450 - 549 (135 - 164)	65 (20)	125 (40)	190 (60)	200 (60)
550 - 649 (165 - 199)	70 (20)	140 (45)	200 (60)	200 (60)
650 - 749 (200 - 229)	75 (25)	150 (45)	200 (60)	200 (60)
750 - 849 (230 - 259)	80 (25)	165 (50)	200 (60)	200 (60)
850 - 949 (260 - 289)	85 (25)	175 (55)	200 (60)	200 (60)
950 - 1049 (290 - 319)	90 (25)	185 (55)	200 (60)	200 (60)
1050 - 1299 (320 - 394)	100 (30)	200 (60)	200 (60)	200 (60)
1300 - 1999 (395 - 609)	125 (40)	200 (60)	200 (60)	300 (90)
2000 - 2999 (610 - 914)	150 (45)	200 (60)	200 (60)	300 (90)
3000 - 3999 (915 - 1219)	175 (55)	200 (60)	300 (90)	300 (90)
4000 or greater (1220)	400 (120)	400 (120)	400 (120)	400 (120)

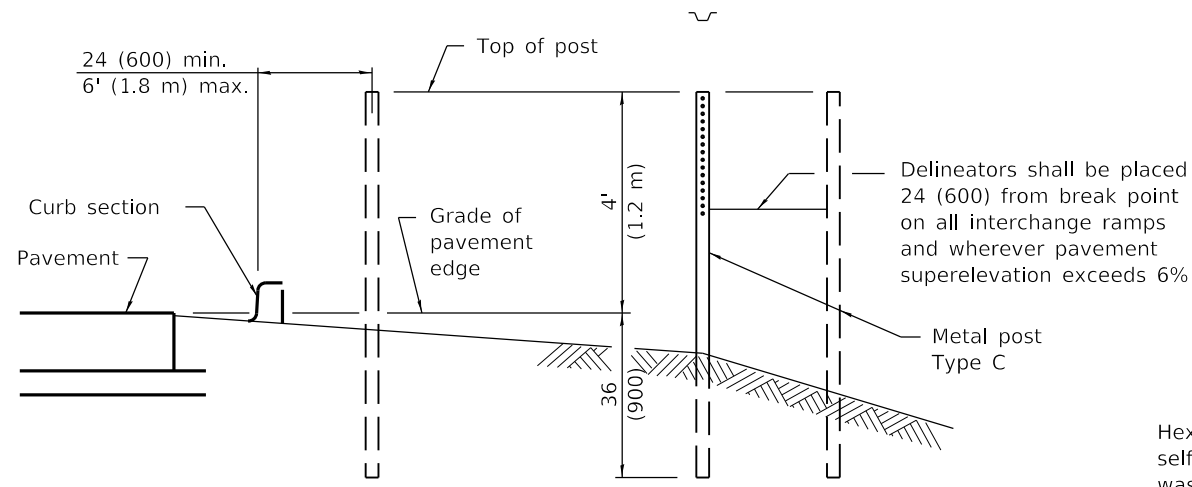

SECTIONAL VIEW

Hex head bolt with self locking nut and washer

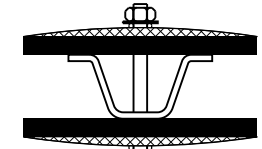

Two sided

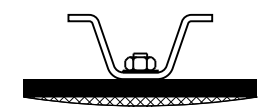

One sided

Hex head bolt with self locking nut and washer

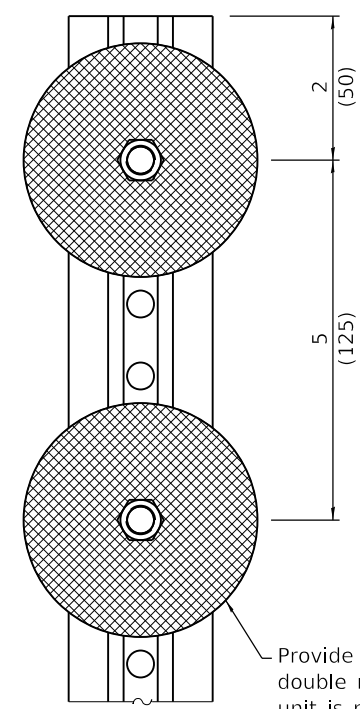

ELEVATION

REFLECTOR ATTACHED TO POST

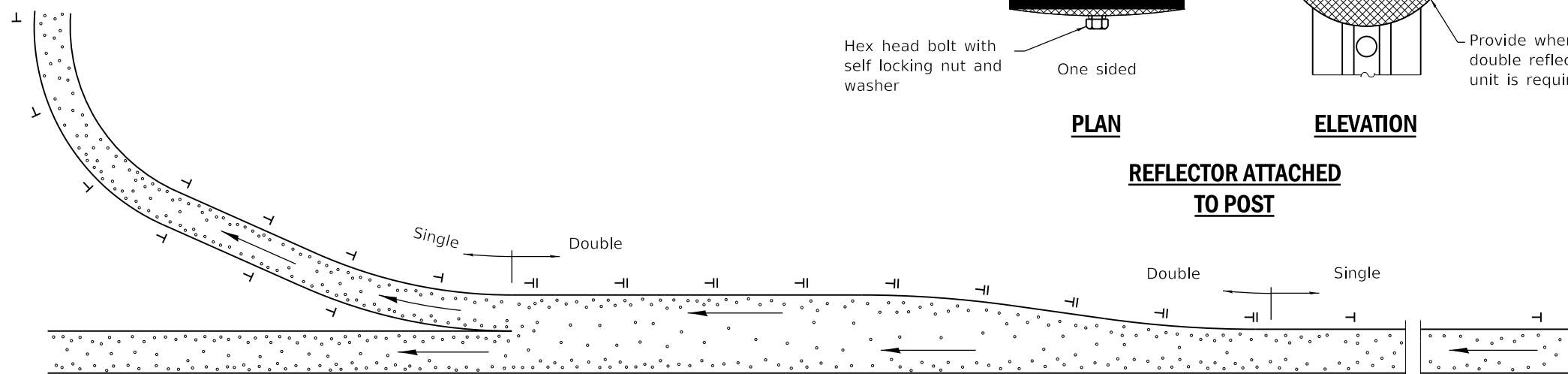

PLAN - DUAL HIGHWAYS

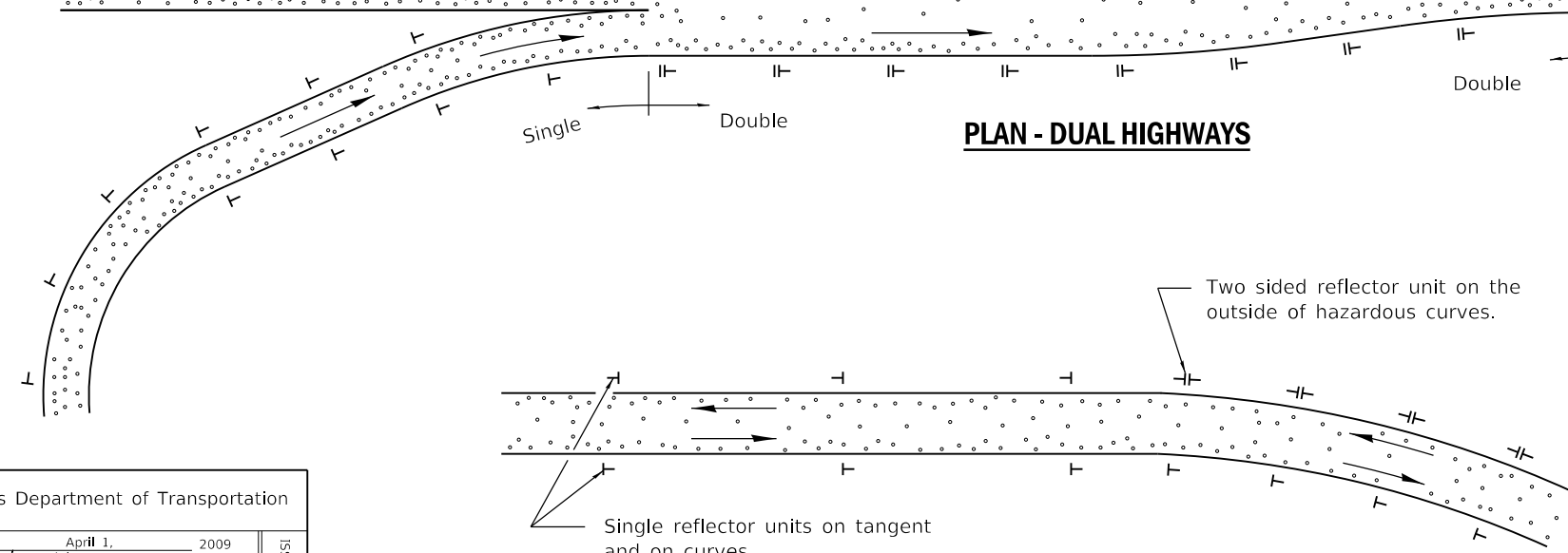

PLAN - TWO-WAY ROADWAYS

GENERAL NOTES

Delineators on tangent sections of main line roadways shall be placed at 400' (120 m) spacing. Delineators on ramps and acceleration and deceleration lanes shall be placed at a maximum spacing of 100' (30 m).

Refer to Standard 720011 for details of metal post.

Double reflector units shall be used on the outside of all acceleration and deceleration lanes. Single reflector units shall be used on ramps. Delineators shall be used on outside of all curved sections of ramps.

All dimensions are in inches (millimeters) unless otherwise shown.

DATE	REVISIONS
4-1-16	Added detail of reflector attached to post. Revised signature block.
1-1-09	Switched units to English (metric). Revised notes.

DELINEATORS

STANDARD 635001-02

Illinois Department of Transportation

PASSED April 1, 2009
Amy Allen
 ENGINEER OF OPERATIONS

APPROVED April 1, 2009
[Signature]
 ENGINEER OF DESIGN AND ENVIRONMENT

ISSUED 1-1-97

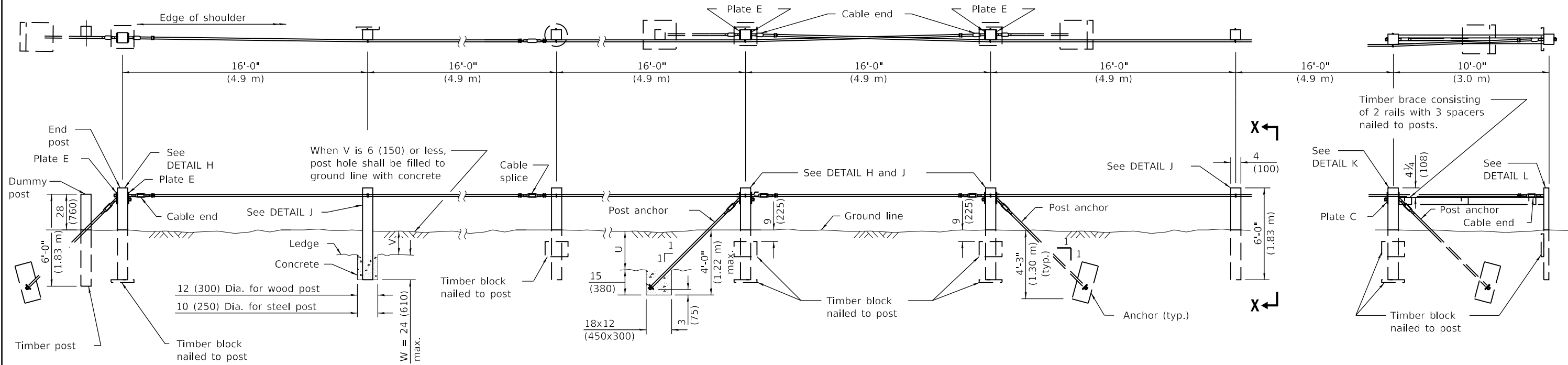

END ANCHOR ARRANGEMENT

TYPICAL FOOTINGS FOR POST AND ANCHOR WHEN IMPERVIOUS MATERIAL IS ENCOUNTERED

INTERMEDIATE ANCHOR ARRANGEMENT

DEAD END ANCHOR ARRANGEMENT

NOTES

V + W shall not exceed 39 (990). When V is 0 to 15 (380), W = 24 (610), and posts shall be shortened as required. When V exceeds 15 (380), W shall be shortened correspondingly.

T = 15 (380) when U is 33 (840) or less. When U exceeds 33 (840) the impervious material shall be removed and the standard anchor shall be used.

Timber blocks shall be nailed to each wood post on the concave side of curve for curves having a radius of less than 600' (180 m).

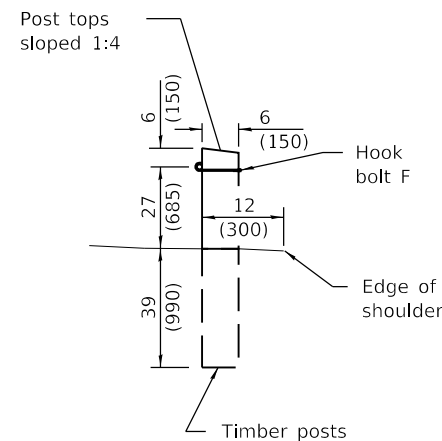

VIEW X-X

Typical Wood Materials	
Item	Size
Post	4x4x6'-0" (100x150x1.83 m)
Block	2x12x18 (50x300x450)
Rail	2x6 (50x150)
Spacer	2x6x6 (50x150x150)

GENERAL NOTES

The Engineer will determine the stability of the impervious material for anchoring.

All slope ratios are expressed as units of vertical displacement to units of horizontal displacement (V:H).

All dimensions are in inches (millimeters) unless otherwise shown.

Illinois Department of Transportation

PASSED January 1, 2009

ENGINEER OF POLICY AND PROCEDURES

APPROVED January 1, 2009

ENGINEER OF DESIGN AND ENVIRONMENT

ISSUED 1-1-97

DATE	REVISIONS
1-1-09	Switched units to Eng. (met.). omitted precast deadman and gen. note.
1-1-05	Corrected note on Post Anchor detail on sheet
	3 of 3.

CABLE ROAD GUARD SINGLE STRAND

(Sheet 1 of 3)

STANDARD 636001-02

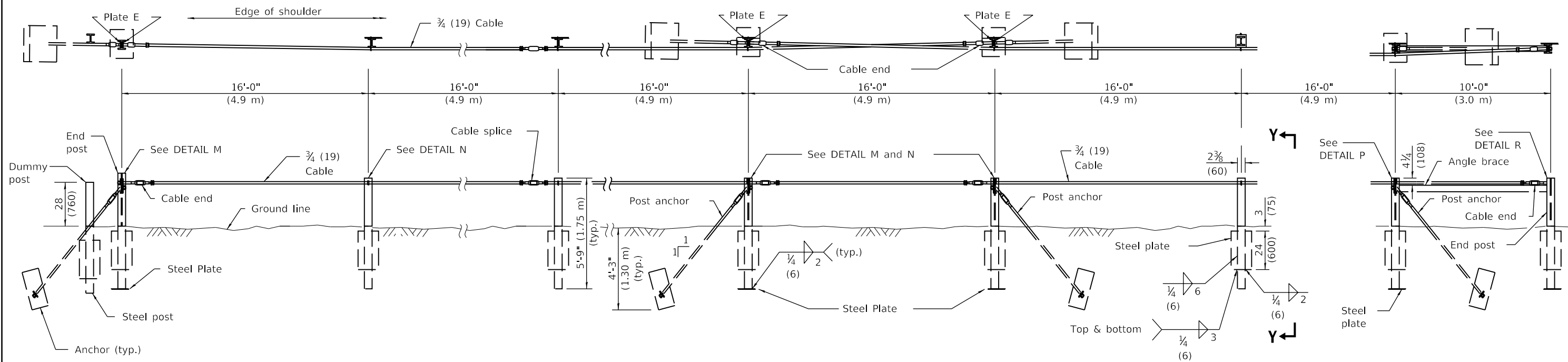

END ANCHOR ARRANGEMENT

INTERMEDIATE ANCHOR ARRANGEMENT

DEAD END ANCHOR ARRANGEMENT

TYPICAL STEEL MATERIALS	
Item	Size
Post	S3x5.7x5'-9" (S75x8.5x1.75 m)
Bottom Plate	1/4x8x8 (6x200x200)
Side Plate	1/4x8x24 (6x200x600)
Brace	L 4x3x3/8 (L 102x76x9.5)

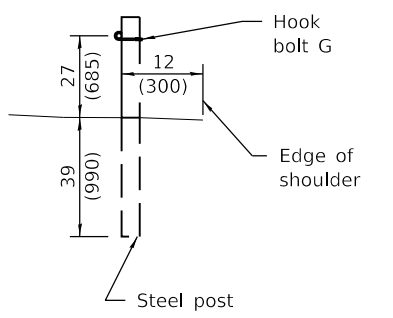

VIEW Y-Y

Illinois Department of Transportation
 PASSED January 1, 2009
 ENGINEER OF POLICY AND PROCEDURES
 APPROVED January 1, 2009
 ENGINEER OF DESIGN AND ENVIRONMENT

CABLE ROAD GUARD
SINGLE STRAND
 (Sheet 2 of 3)
STANDARD 636001-02

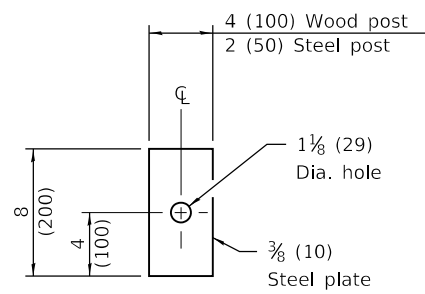

PLATE C

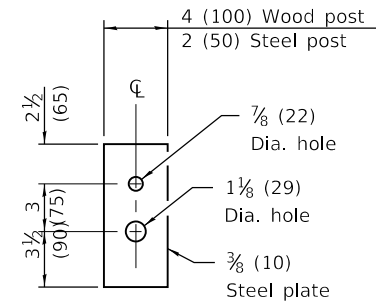
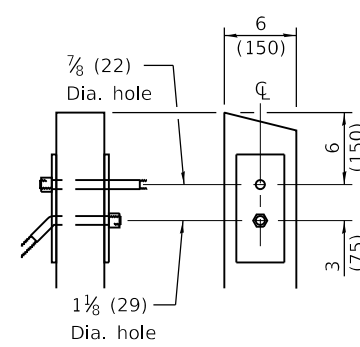
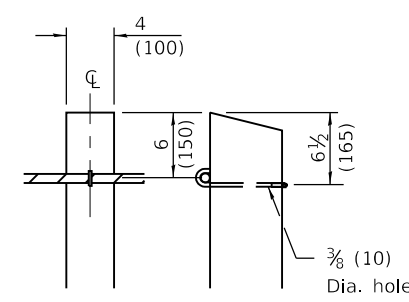

PLATE E



DETAIL H



DETAIL J

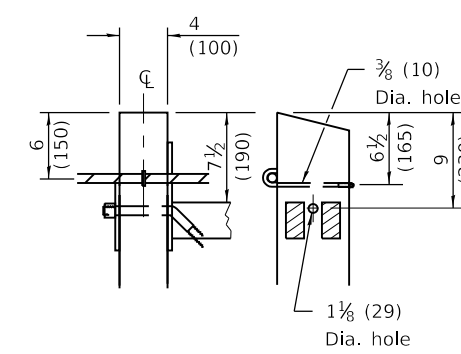

DETAIL K

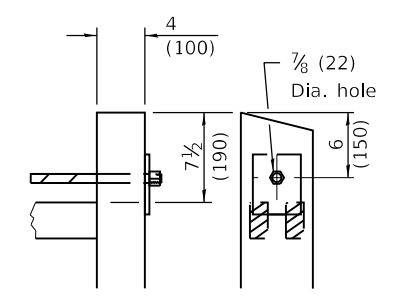

DETAIL L

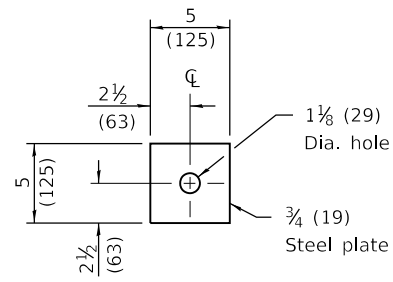

PLATE B

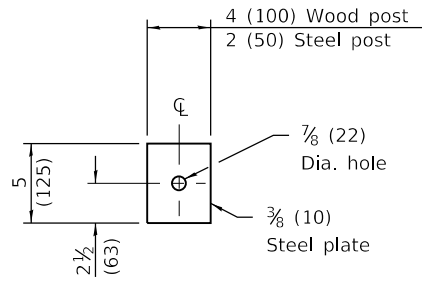
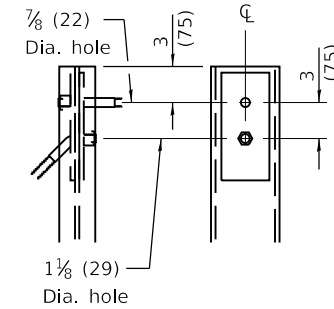
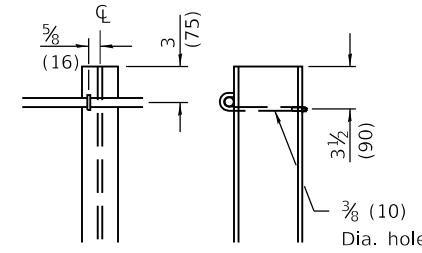

PLATE D



DETAIL M



DETAIL N

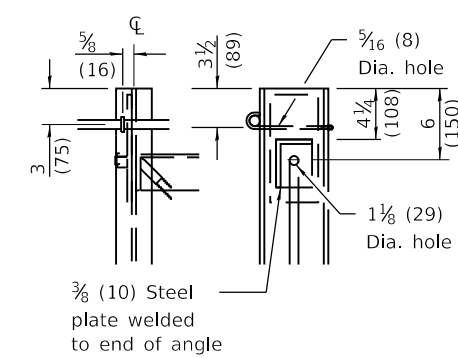

DETAIL P

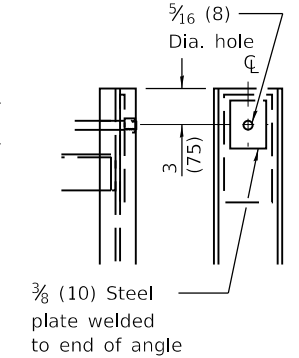

DETAIL R

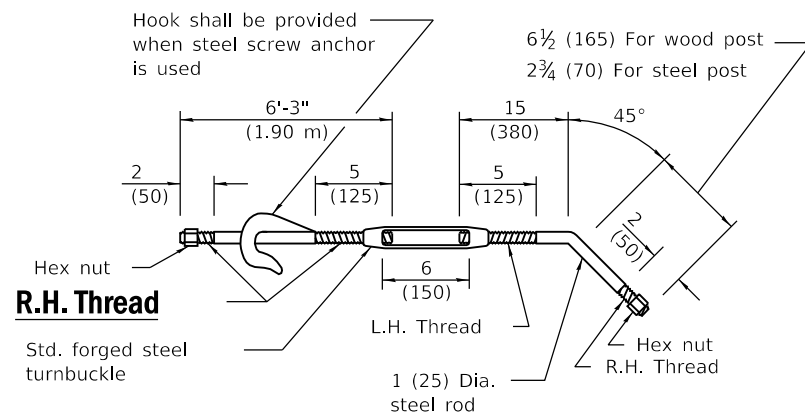

POST ANCHOR

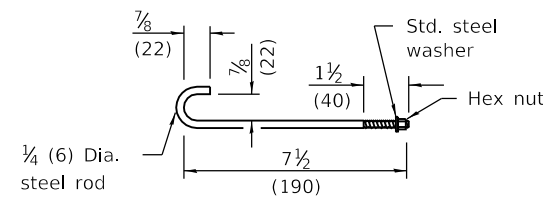

HOOK BOLT F

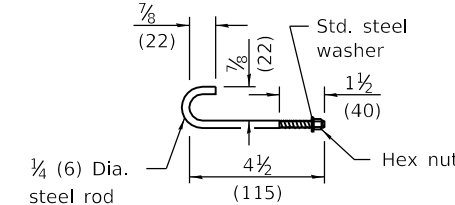

HOOK BOLT G

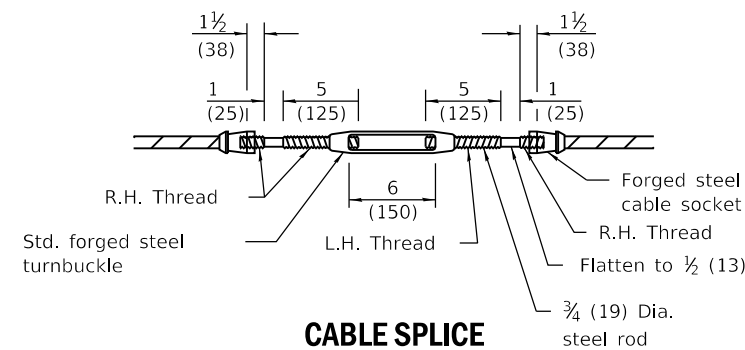

CABLE SPLICE

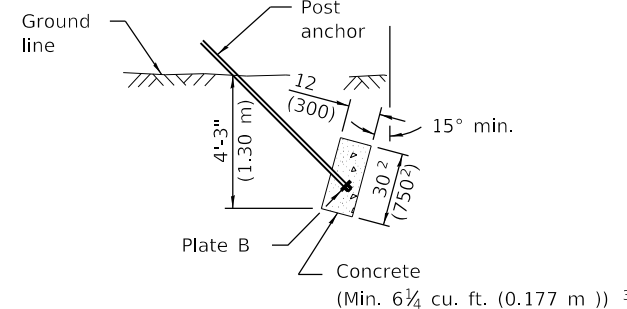

CAST IN PLACE DEADMAN

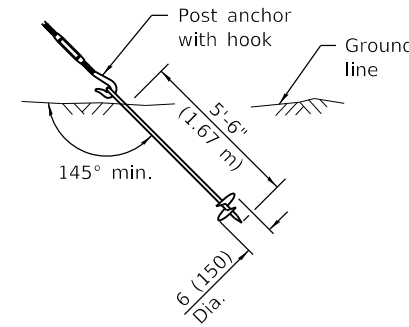

STEEL SCREW

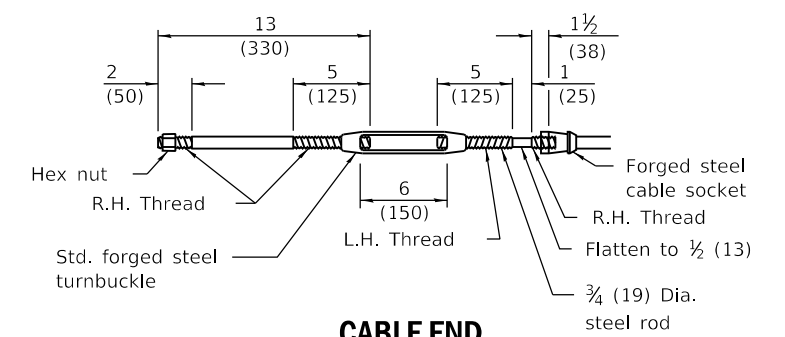

CABLE END

Illinois Department of Transportation
 PASSED January 1, 2009
 ENGINEER OF POLICY AND PROCEDURES
 APPROVED January 1, 2009
 ENGINEER OF DESIGN AND ENVIRONMENT

ISSUED 1-1-97

ALTERNATE - ANCHORS

**CABLE ROAD GUARD
 SINGLE STRAND**

(Sheet 3 of 3)

STANDARD 636001-02

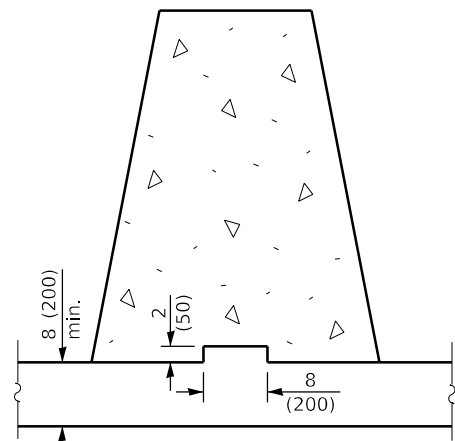

NEW PCC BASE w/ KEYWAY

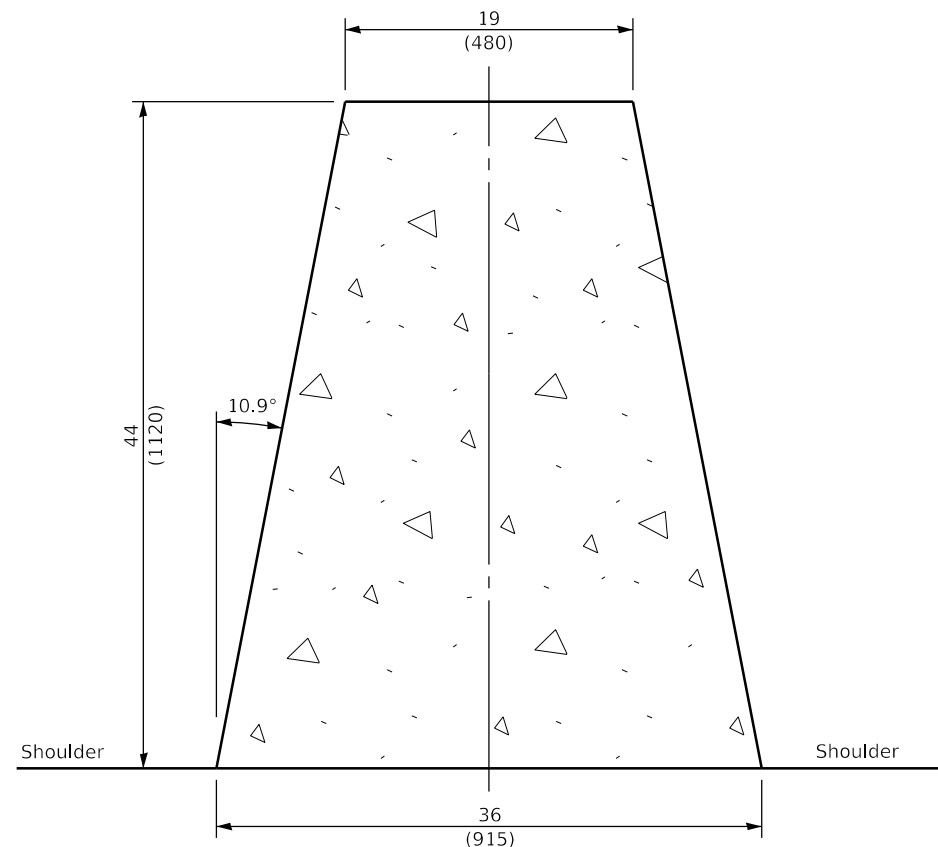

TYPICAL CROSS-SECTION

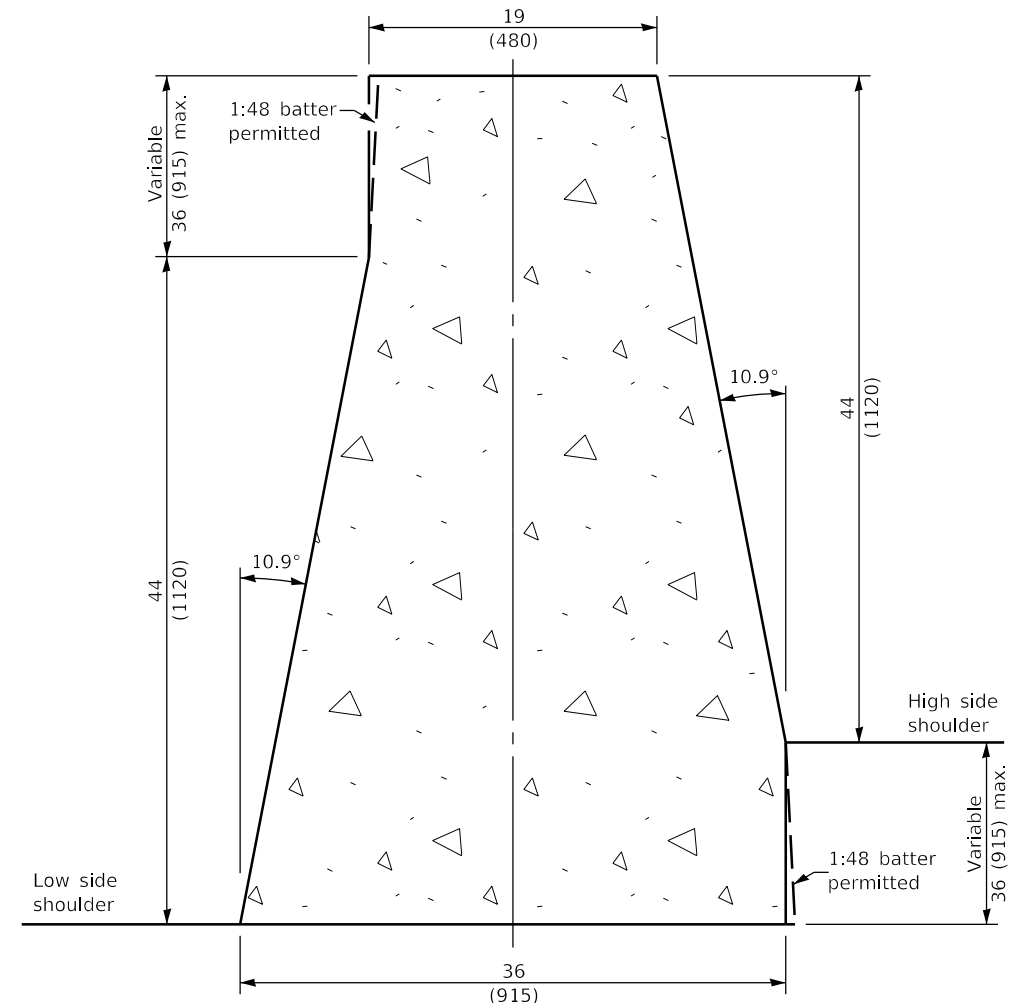

VARIABLE CROSS-SECTION

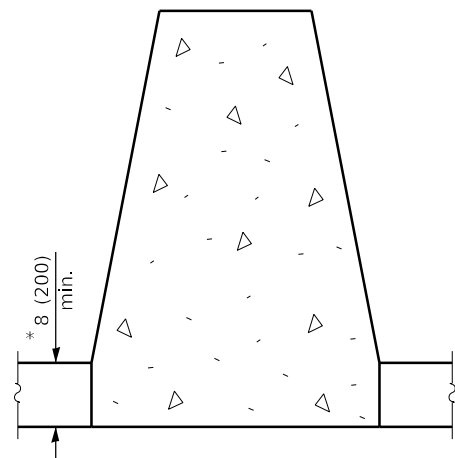

NEW MONOLITHIC PCC BASE

* This dimension shall be 10 (250) min. when the barrier is confined by earth.

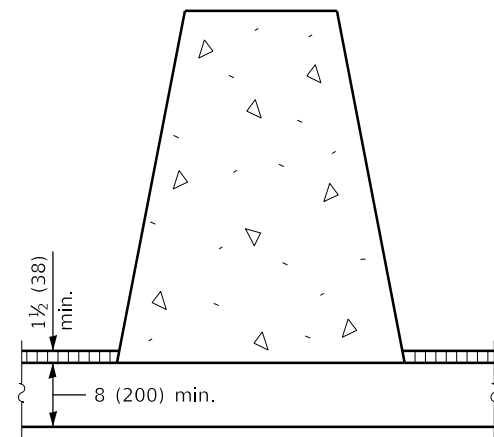

NEW OR EXISTING HMA / PCC BASE w/ HMA OVERLAY CONFINEMENT

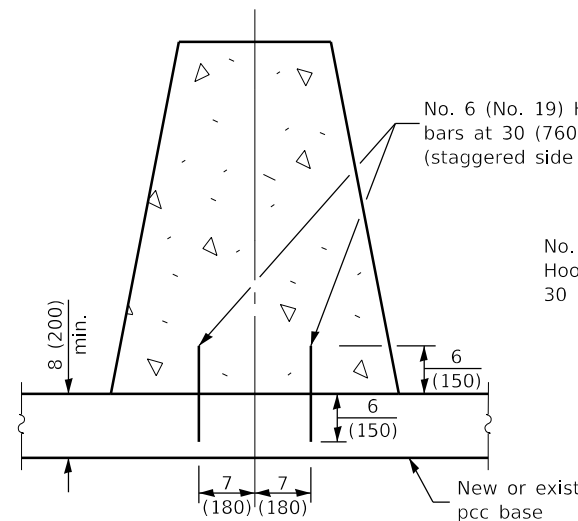

NEW OR EXISTING PCC BASE w/ HOOK BARS

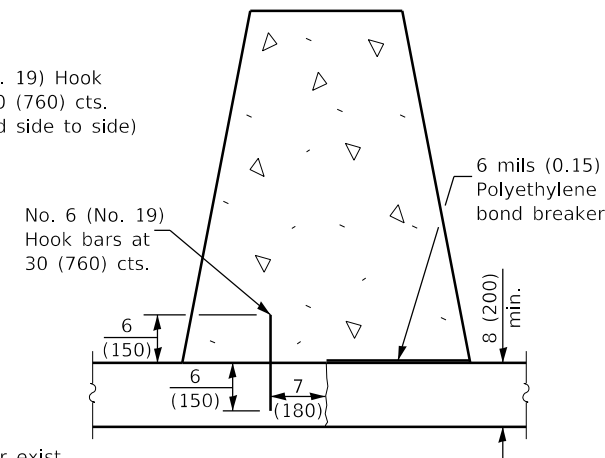

EXISTING PCC BASE WITH LONGITUDINAL JOINT

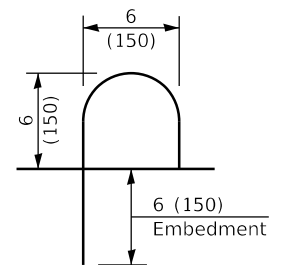

HOOK BAR DETAIL (Side View)

GENERAL NOTES

The Variable Cross-Section shall be used when there is a difference in base elevation between the two sides of the barrier.

See standard 836011 for additional light pole foundation details where required in concrete barrier.

All dimensions are in inches (millimeters) unless otherwise shown.

FIVE ANCHORING METHODS

DATE	REVISIONS
1-1-21	Revised Typical and Variable Cross-Sections. Added keyway anchor method and hook bars.
1-1-19	Revised from F-shape to constant slope, increased height, and renamed standard.

**CONCRETE BARRIER,
DOUBLE FACE,
44 in. (1120 mm) HEIGHT**
(Sheet 1 of 2)

STANDARD 637006-05

Illinois Department of Transportation

PASSED January 1, 2021

 ENGINEER OF POLICY AND PROCEDURES

APPROVED January 1, 2021

 ENGINEER OF DESIGN AND ENVIRONMENT

ISSUED 1-1-97
 76-T

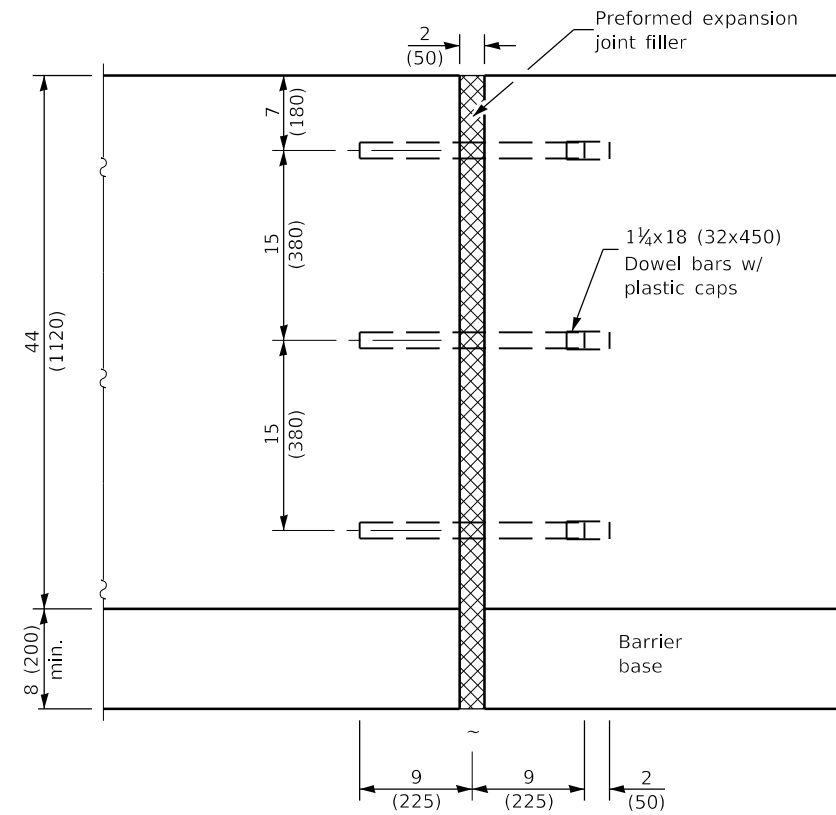

EXPANSION JOINT

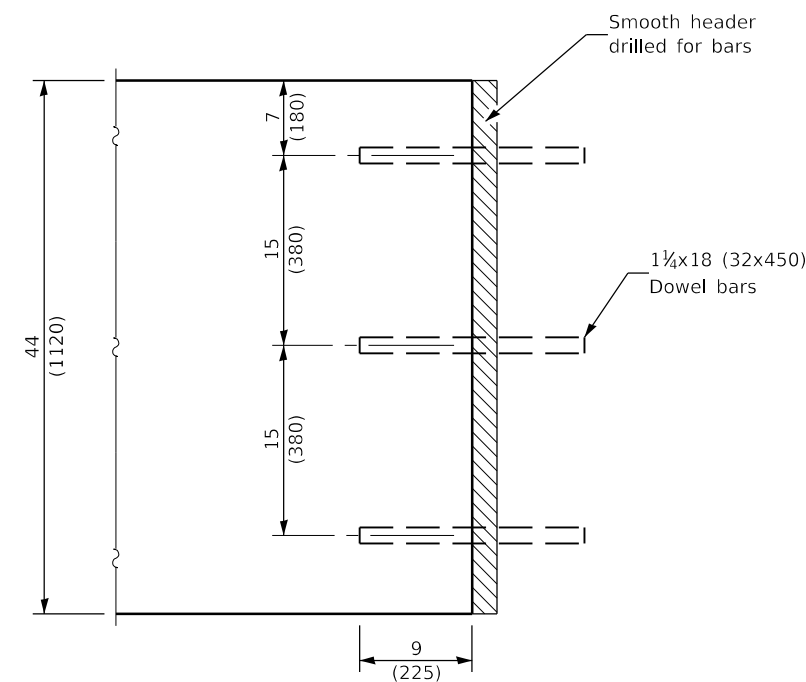

CONSTRUCTION JOINT

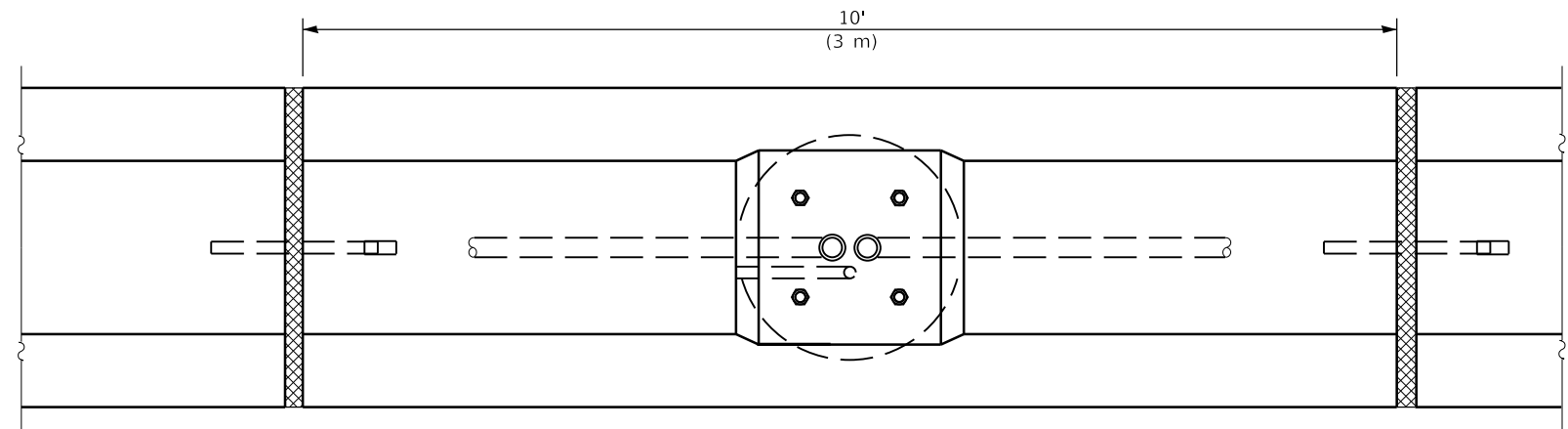

PLAN AT LIGHTING FOUNDATION

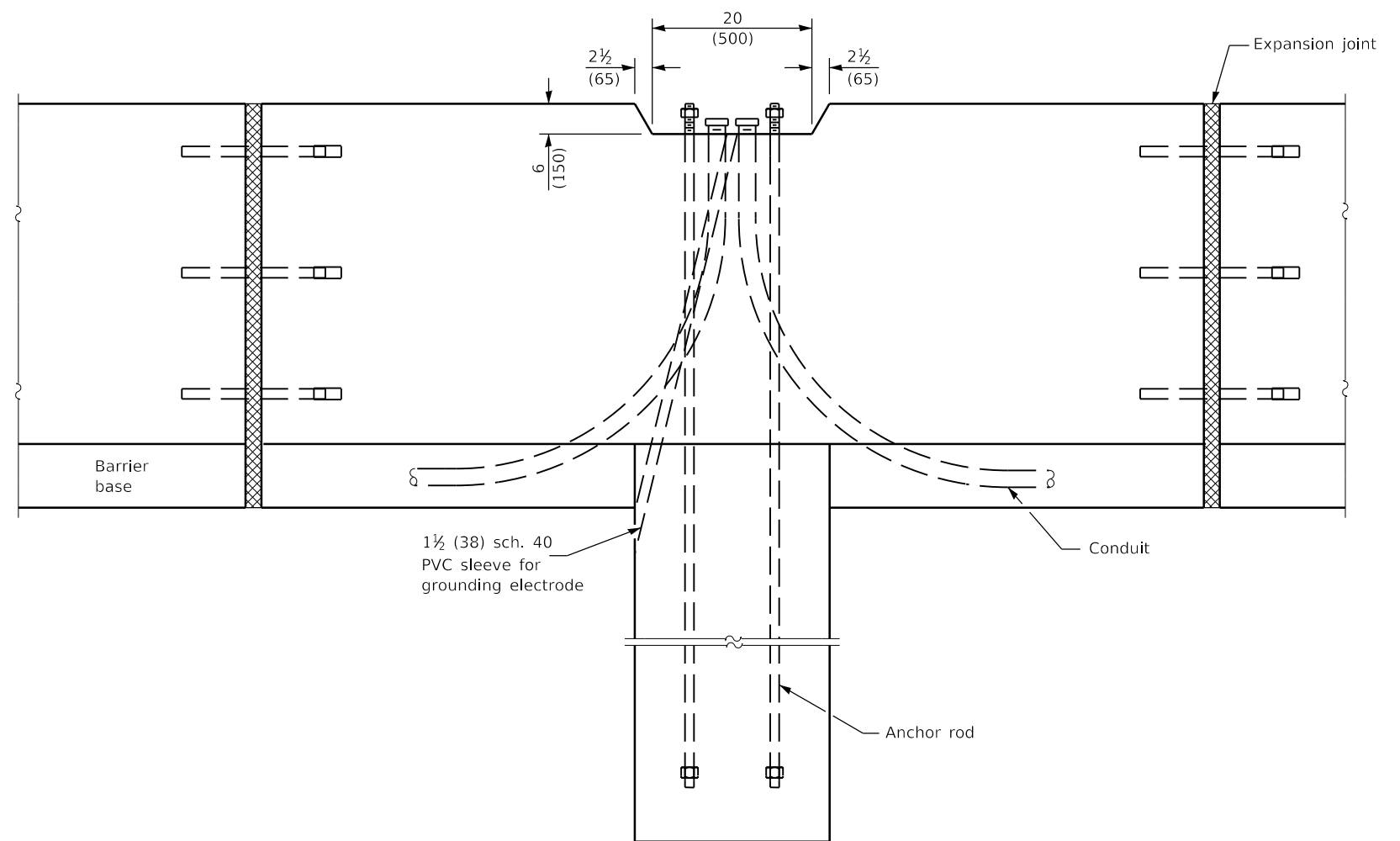

ELEVATION AT LIGHTING FOUNDATION

 Illinois Department of Transportation
 PASSED January 1, 2021
Michael Bond
 ENGINEER OF POLICY AND PROCEDURES
 APPROVED January 1, 2021
John E. ...
 ENGINEER OF DESIGN AND ENVIRONMENT

ISSUES
46-1-1 QMS/SL

**CONCRETE BARRIER,
 DOUBLE FACE,
 44 in. (1120 mm) HEIGHT**
(Sheet 2 of 2)

STANDARD 637006-05

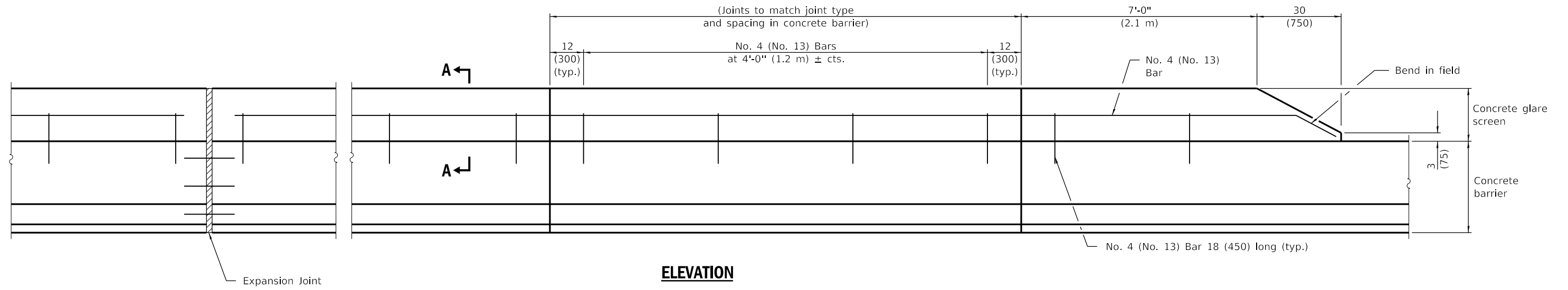

ELEVATION

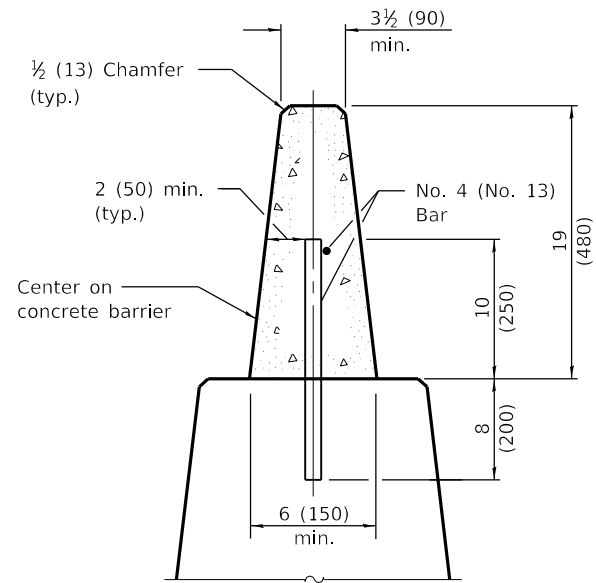

SECTION A-A

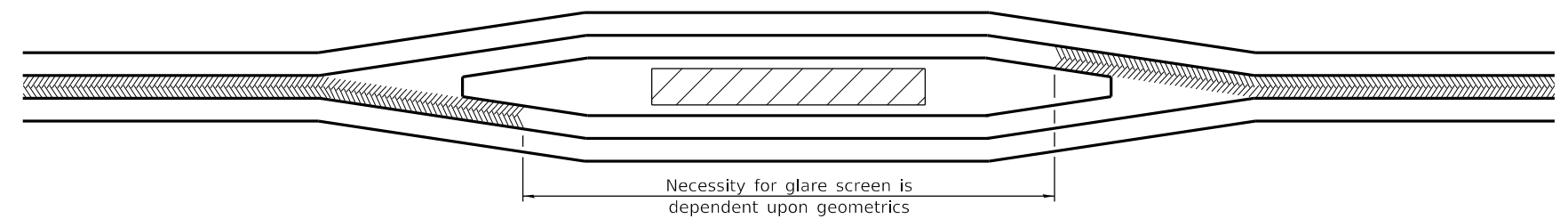

TYPICAL APPLICATION AT MEDIAN OBSTRUCTIONS

 Glare Screen

All dimensions are in inches (millimeters) unless otherwise shown.

Illinois Department of Transportation

PASSED January 1, 2009

ENGINEER OF POLICY AND PROCEDURES

APPROVED January 1, 2009

ENGINEER OF DESIGN AND ENVIRONMENT

ISSUED 1-1-97

DATE	REVISIONS
1-1-09	Switched units to English (metric).
1-1-04	Revised for F shape barrier.

CONCRETE GLARE SCREEN

STANDARD 638101-02

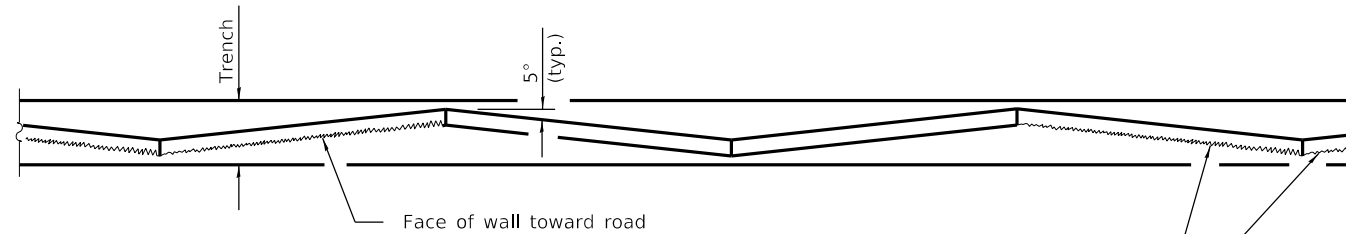

Each alternate pair of panels shall have a textured surface finish as shown, and shall be alternated with pairs having a smooth finish. The intersection of every two panels having the same finish shall point toward the road as shown.

PLAN

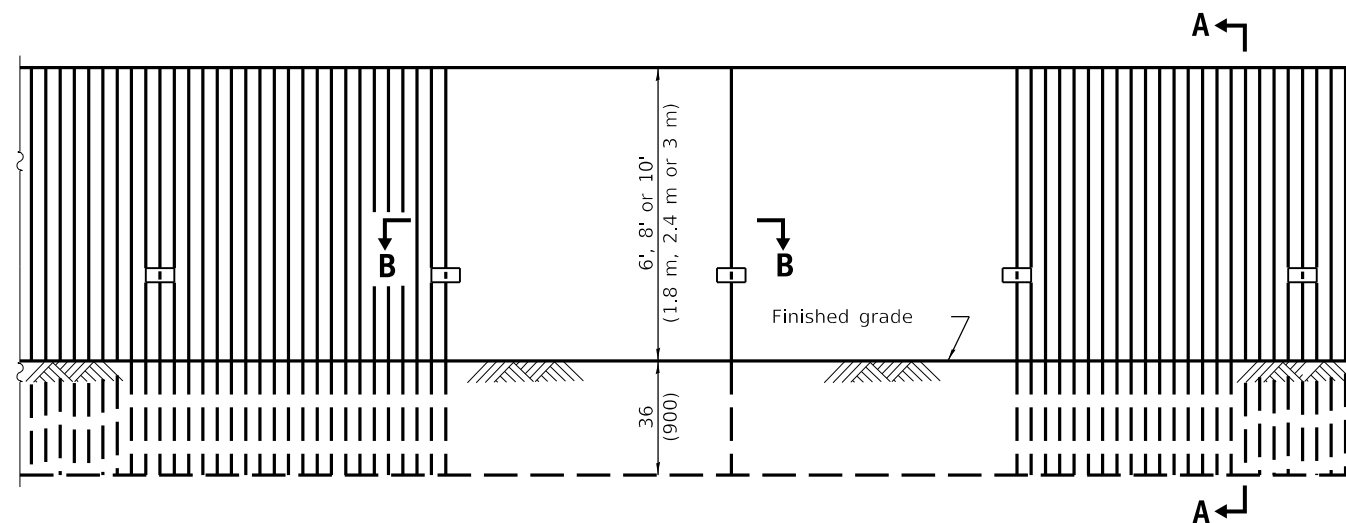

ELEVATION

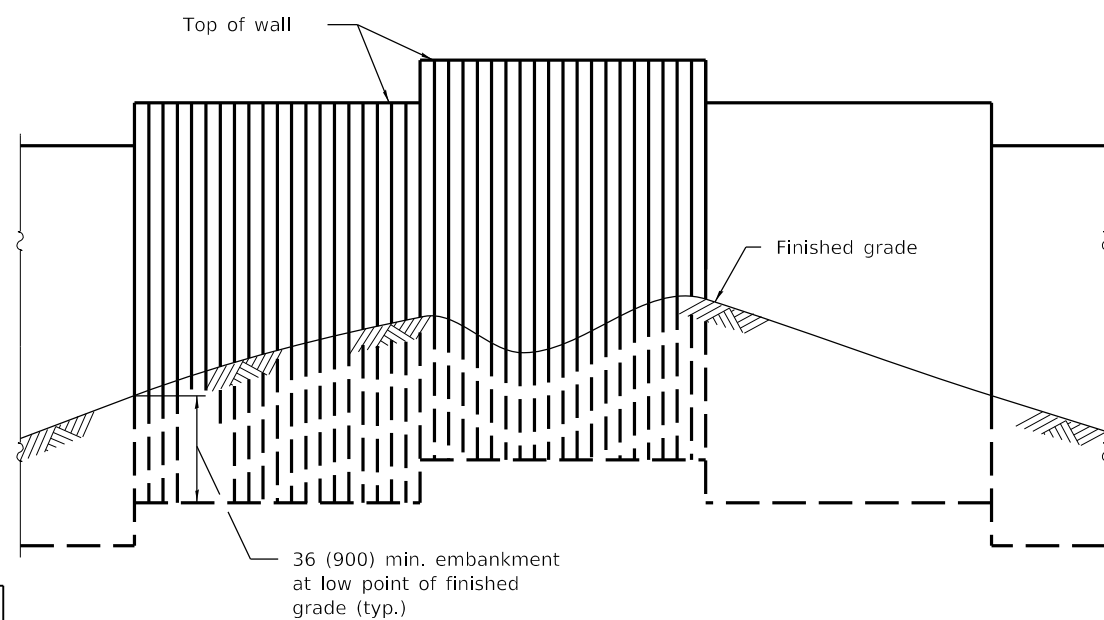

ELEVATION

(Showing installation of wall in irregular ground)

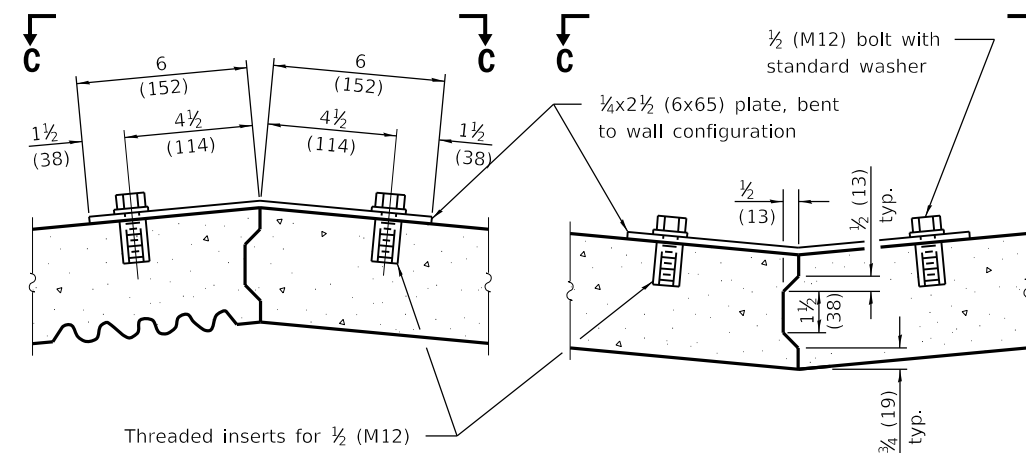

Threaded inserts for ½ (M12) bolts, precast or field drilled, as necessary, into panels.

Showing typical metal band connector dimensions

Showing typical shear key dimensions

SECTION B-B

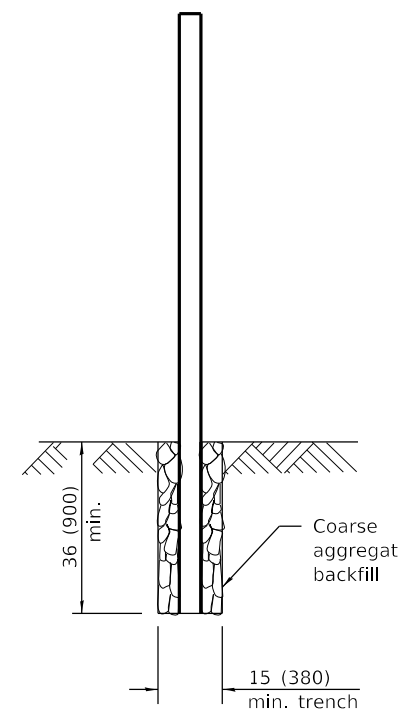

SECTION A-A

GENERAL NOTES

Loading for 80 mph (130 km/h) wind with 30% gust factor, normal to wall.

ALLOWABLE STRESSES:

- Concrete: $f'_c = 3,500$ psi (24 MPa)
 $f'_{ci} = 2,250$ psi (15 MPa)
- Prestressing Steel: $f'_s = 270,000$ psi (1860 MPa)
 $f_{si} = 189,000$ psi (1300 MPa)
- Reinforcing Steel: $f'_y = 40,000$ psi min. (270 MPa)
- Structural Steel: $f_s = 20,000$ psi (138 MPa)
- Minimum allowable soil bearing pressure: = 1.25 tsf (120 kPa)

All dimensions are in inches (millimeters) unless otherwise shown.

DATE	REVISIONS
1-1-09	Switched units to English (metric).
1-1-07	Soft converted metric reinforcement bars & corrected dimensions.

**SIGHT SCREEN
PRECAST PRESTRESSED
CONCRETE PANEL WALL**

(Sheet 1 of 2)

STANDARD 639001-02

Illinois Department of Transportation

APPROVED January 1, 2009
Ralph E. Anderson
ENGINEER OF BRIDGES AND STRUCTURES

APPROVED January 1, 2009
Lee E. Han
ENGINEER OF DESIGN AND ENVIRONMENT

ISSUED 1-1-97

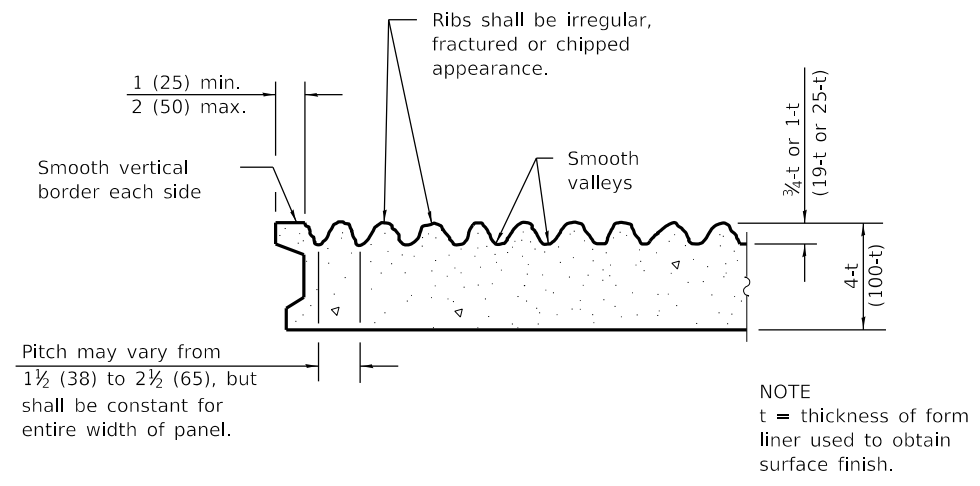
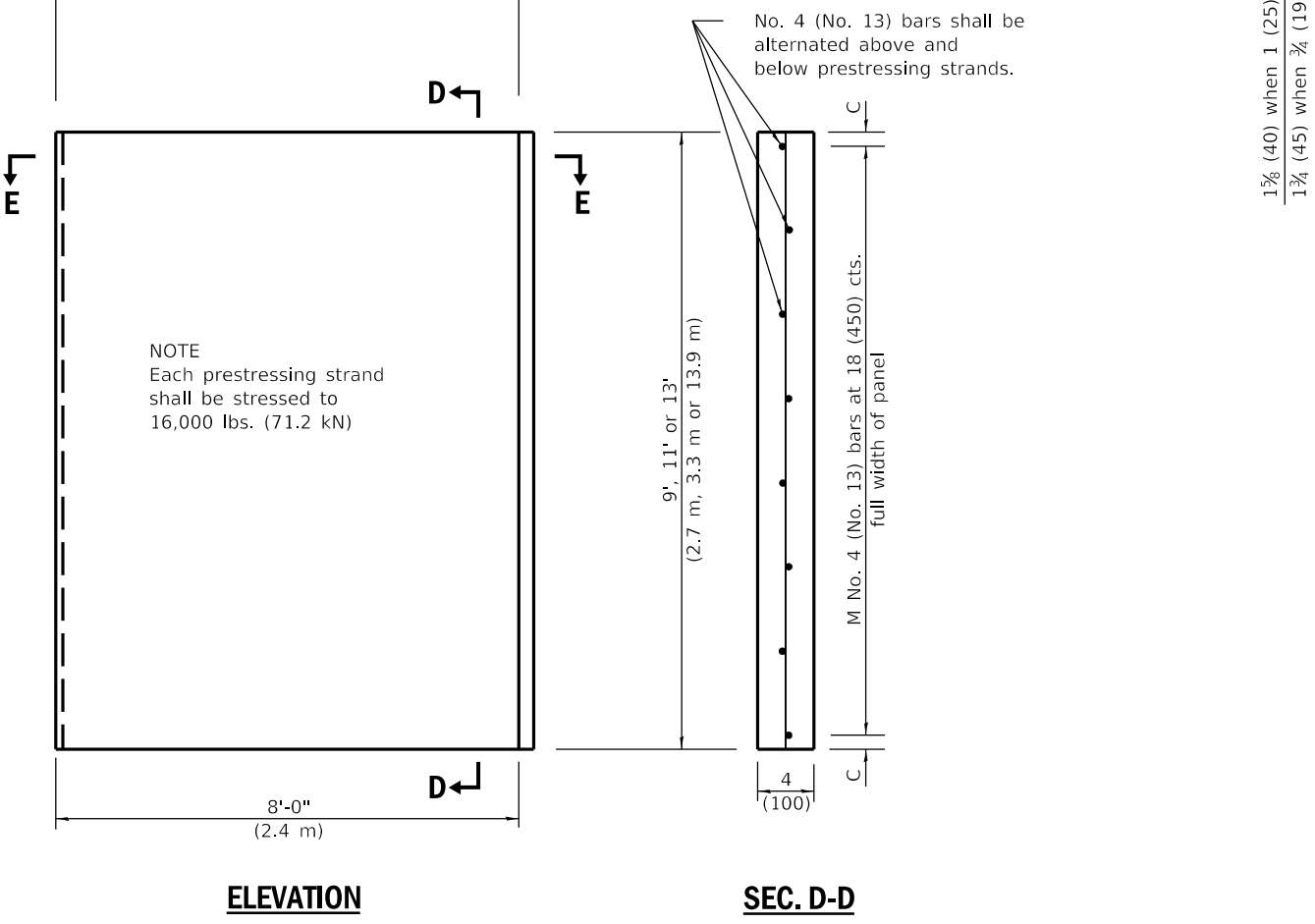
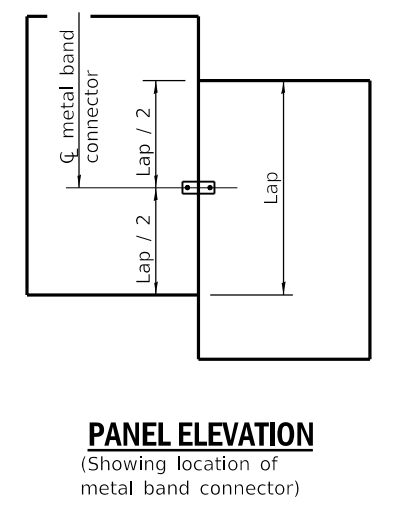
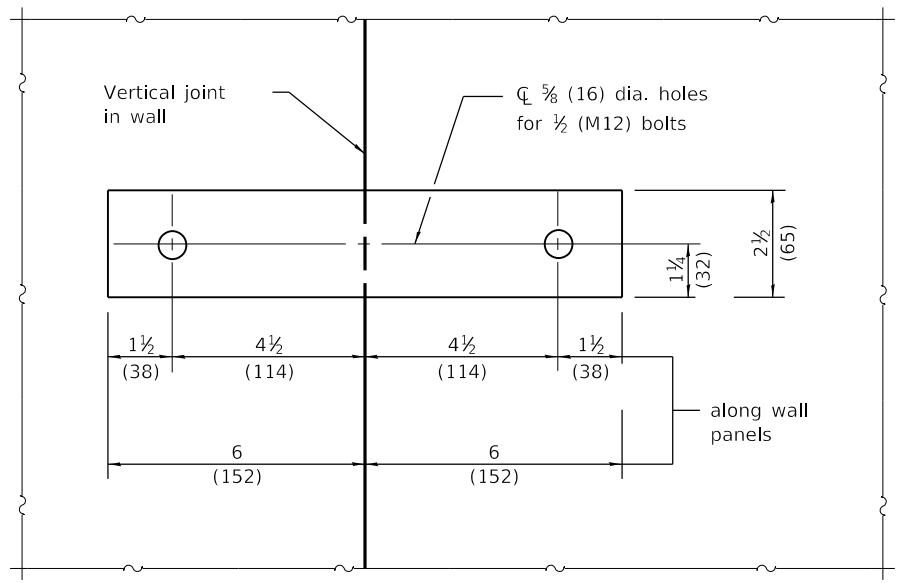
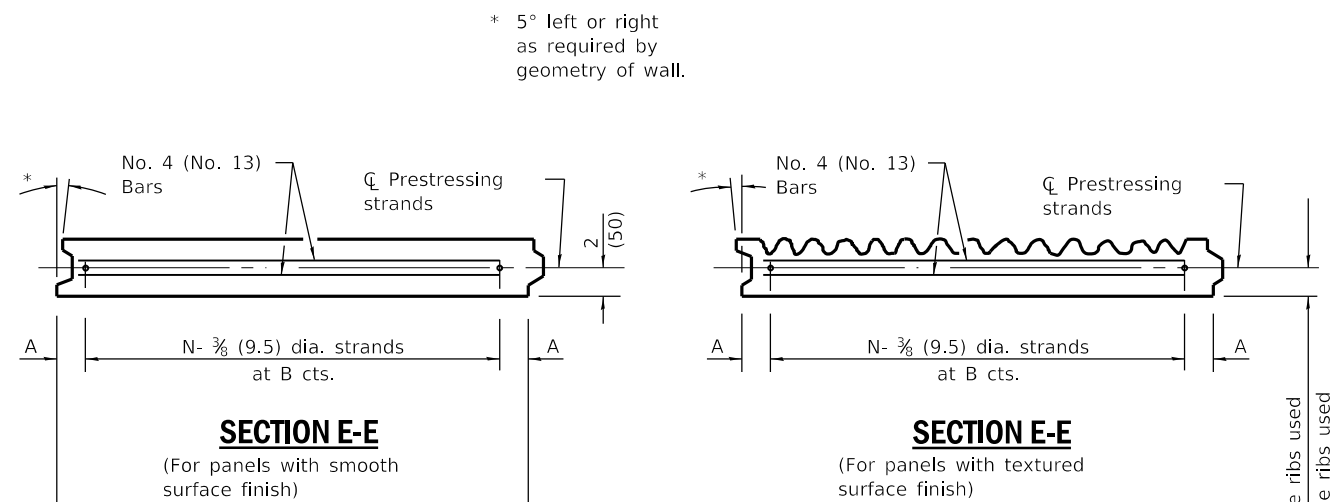

STRAND and REINFORCEMENT LAYOUT

Nominal Panel Size	A	N	B	C	M
8'-0" x 9'-0" (2.4 m x 2.7 m)	6 (150)	8	12 (300)	9 (225)	6
8'-0" x 11'-0" (2.4 m x 3.3 m)	3 (75)	11	9 (225)	3 (75)	8
8'-0" x 13'-0" (2.4 m x 3.9 m)	3 (75)	16	6 (150)	6 (150)	9

Illinois Department of Transportation

APPROVED January 1, 2009
Ralph E. Anderson
 ENGINEER OF BRIDGES AND STRUCTURES

APPROVED January 1, 2009
Ken E. Han
 ENGINEER OF DESIGN AND ENVIRONMENT

ISSUED 1-1-97

**SIGHT SCREEN
 PRECAST PRESTRESSED
 CONCRETE PANEL WALL**
 (Sheet 2 of 2)

STANDARD 639001-02

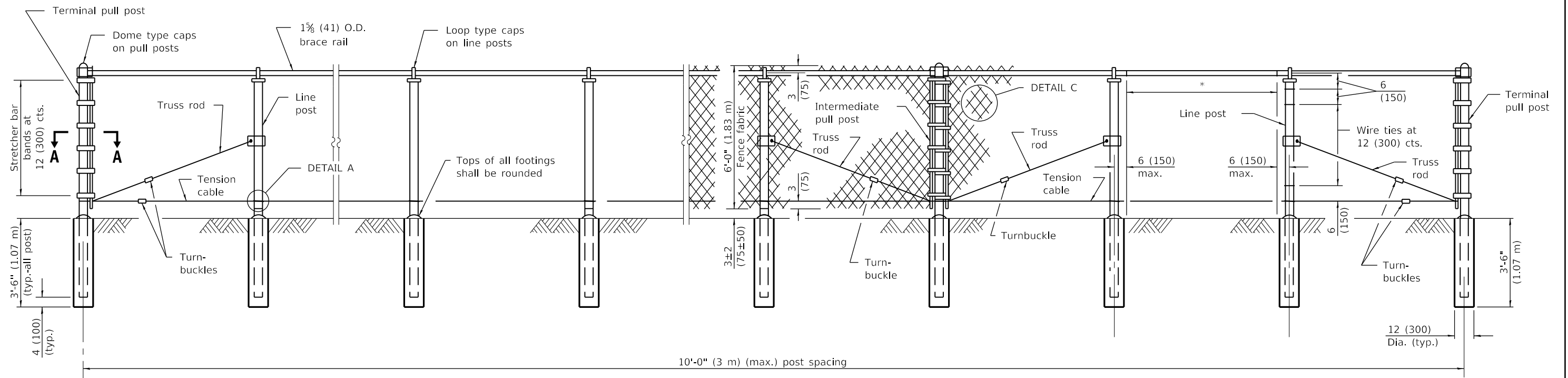

ELEVATION - 6' (1.83 m) FENCE

(Looking toward highway)

* Fence fabric shall be tied to all line posts, tension cable and brace rails with 9 ga. (3.76) wire ties at 12 (300) cts.

FENCE HEIGHT	POST SECTION (O.D.)	lbs./ft. (kg/m)
6 ft. (1.83 m)	4 (102)	9.11 (13.6)
8 ft. (2.43 m)	4 (102)	12.51 (18.6)
10 ft. (3.05 m)	4 (102)	22.85 (34)

Post sizes other than those shown may be used subject to approval by the Engineer.

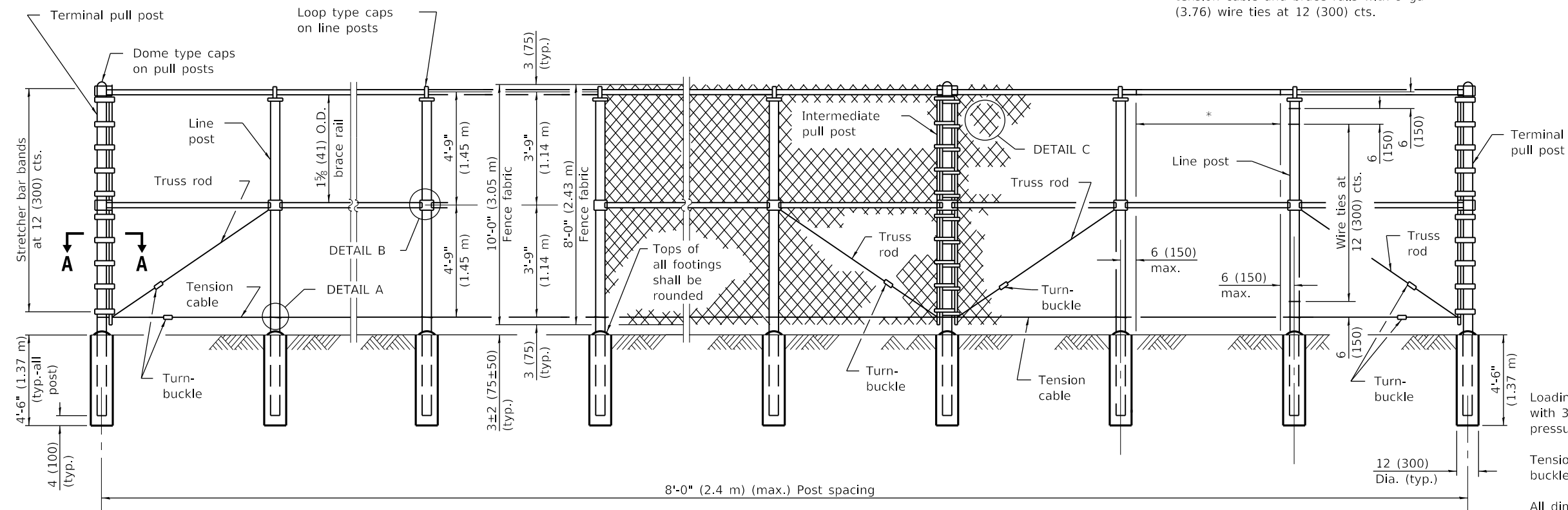

ELEVATION - 8' (2.43 m) & 10' (3.05 m) FENCES

(Looking toward highway)

GENERAL NOTES
 Loading for wind 80 mph (130 km/h) with 30% gust factor. Minimum allowable soil pressure = 1.25 tsf (120 kPa).
 Tension cable shall be provided with one turn buckle between each pair of pull posts.
 All dimensions are in inches (millimeters) unless otherwise shown.

DATE	REVISIONS
1-1-09	Switched units to English (metric). Revised General Notes.
1-1-97	Renum. Standard 2365-6.

SIGHT SCREEN CHAIN LINK FENCE

(Sheet 1 of 2)

STANDARD 640001-01

Illinois Department of Transportation

APPROVED January 1, 2009
Ralph E. Anderson
 ENGINEER OF BRIDGES AND STRUCTURES

APPROVED January 1, 2009
Ken E. Han
 ENGINEER OF DESIGN AND ENVIRONMENT

ISSUED 1-1-97

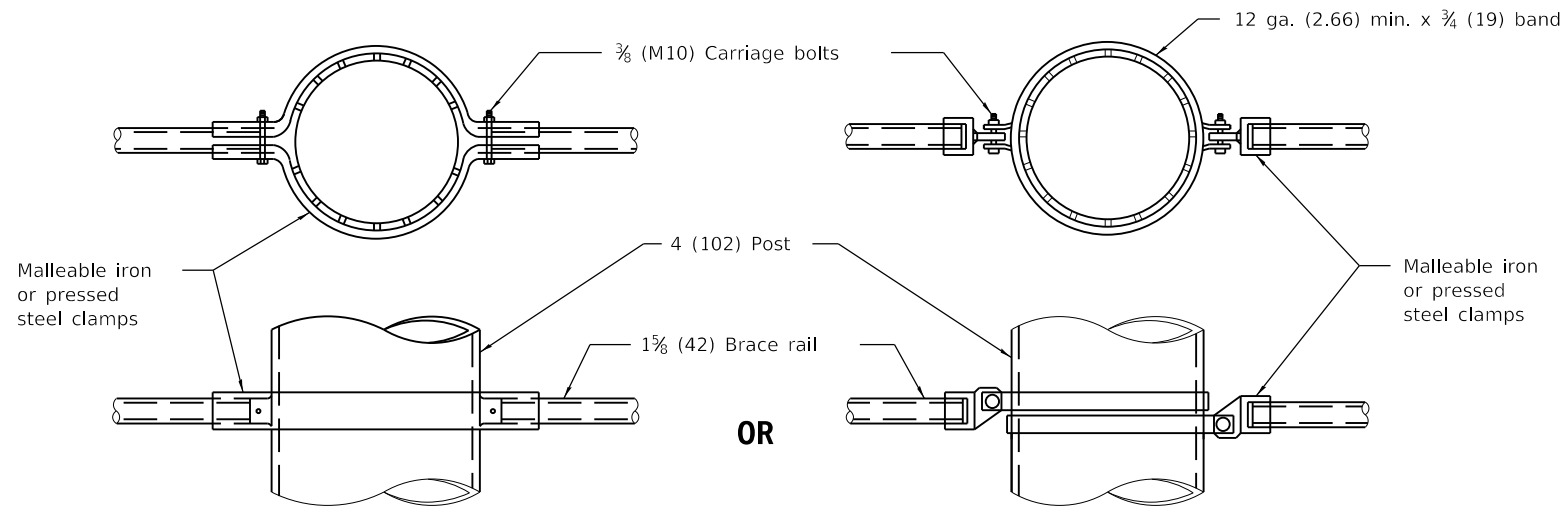

DETAIL B

(Showing typical method of attaching middle brace rails to posts.)

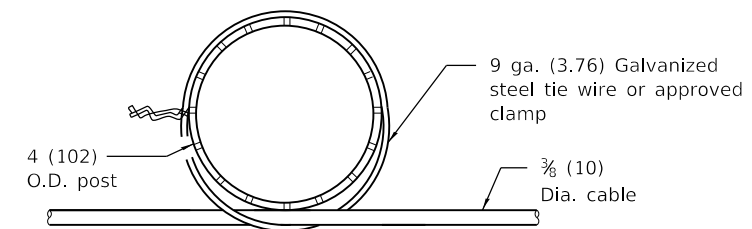

PLAN

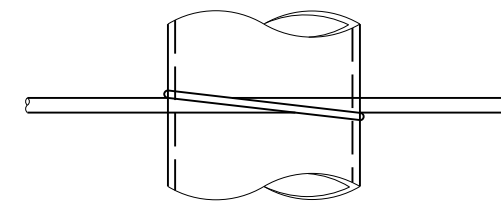

DETAIL A

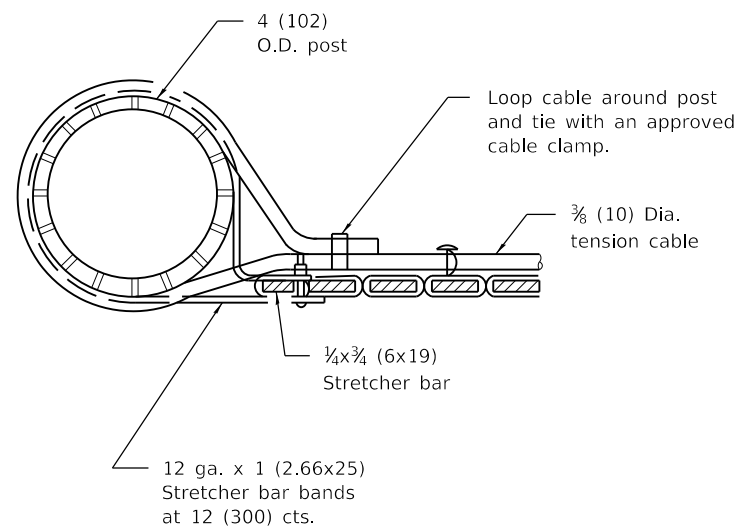

SECTION A-A

(Showing method of fastening bottom tension cable and fence fabric to pull posts.)

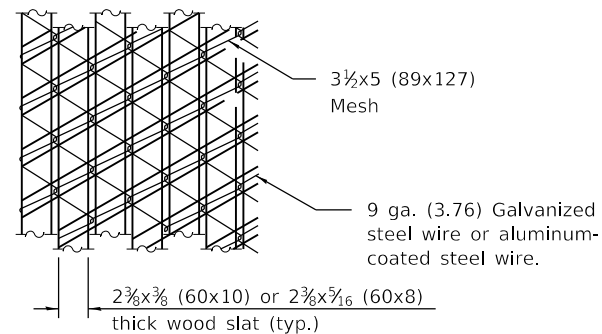

DETAIL OF FABRIC

(Looking from highway)

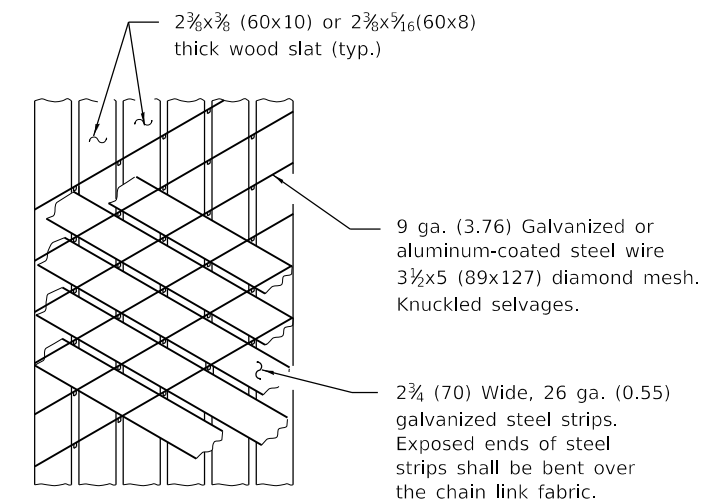

DETAIL C

(Looking toward highway)

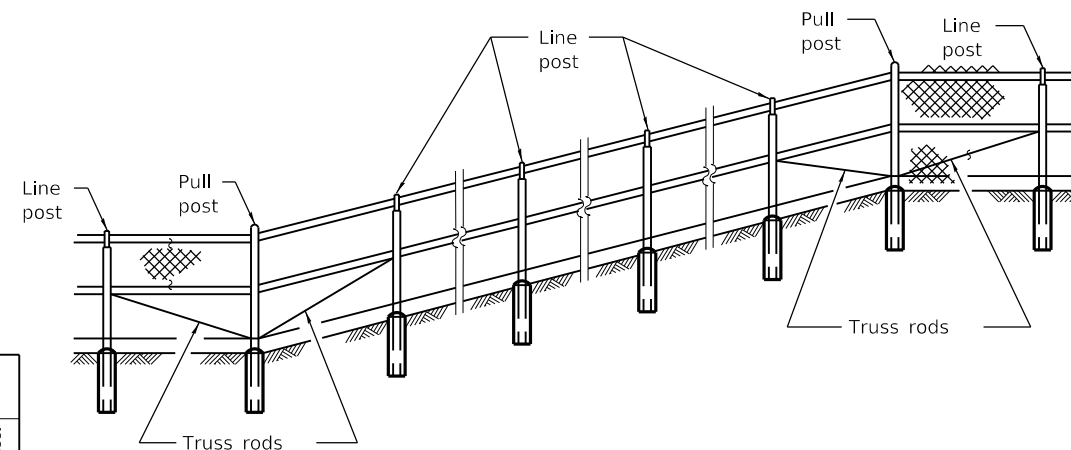

FENCE INSTALLATION ON SLOPES

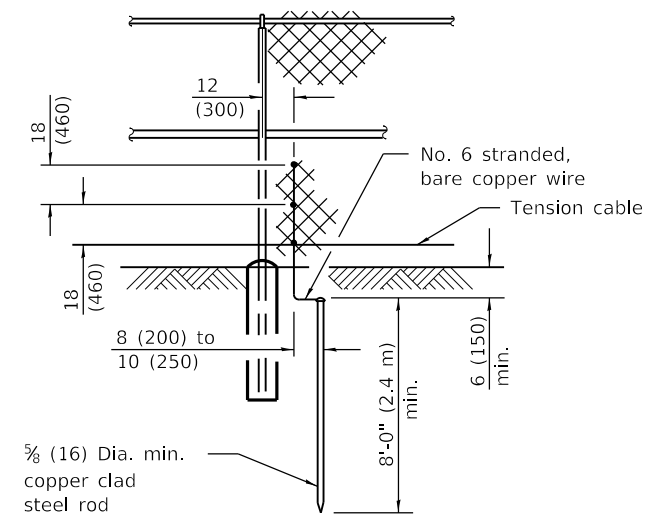

PROTECTIVE ELECTRICAL GROUND

SIGHT SCREEN CHAIN LINK FENCE

(Sheet 2 of 2)

STANDARD 640001-01

Illinois Department of Transportation

APPROVED January 1, 2009
Ralph E. Anderson
 ENGINEER OF BRIDGES AND STRUCTURES

APPROVED January 1, 2009
Lee E. Han
 ENGINEER OF DESIGN AND ENVIRONMENT

ISSUED 1-1-97

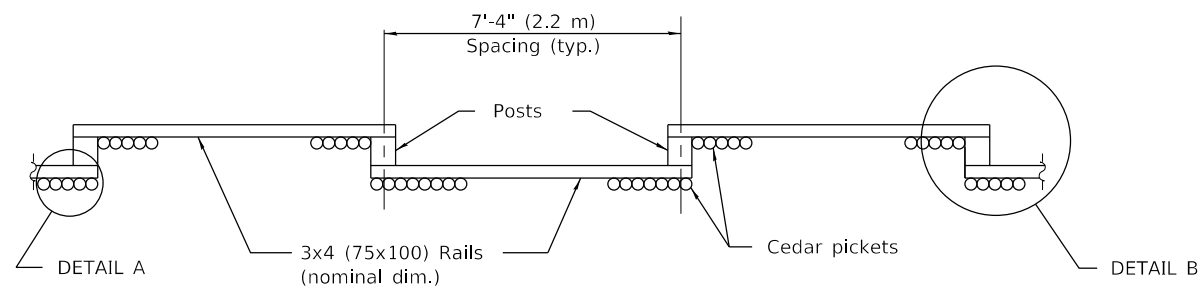

PLAN
(Facing highway)

	FENCE HEIGHT	
	6'-0" (1.8 m)	8'-0" (2.4 m)
Post Size (nominal dim.)	6x8 (150x200)	8x8 (200x200)
Post Length	10'-0" (3.0 m)	14'-0" (4.3 m)
Post Embedment	4'-0" (1.2 m)	6'-0" (1.8 m)
A	15 (380)	18 (460)
B	24 (600)	33 (870)
C	24 (600)	33 (870)
D	12 (300)	15 (380)

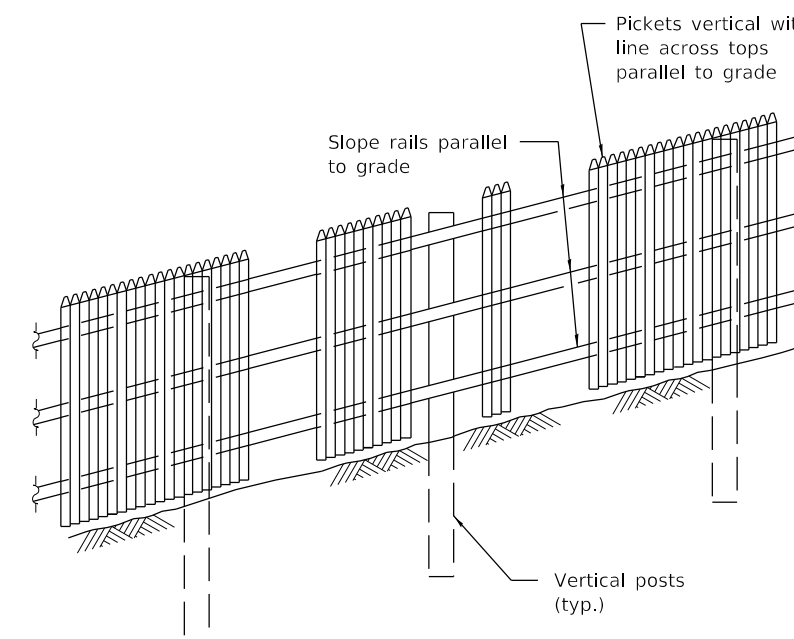

ELEVATION
(Showing treatment with sloping ground)

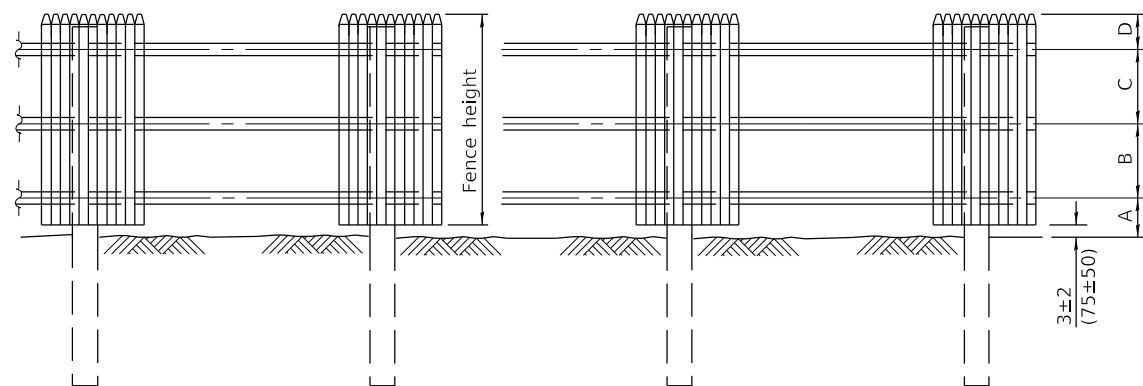

ELEVATION

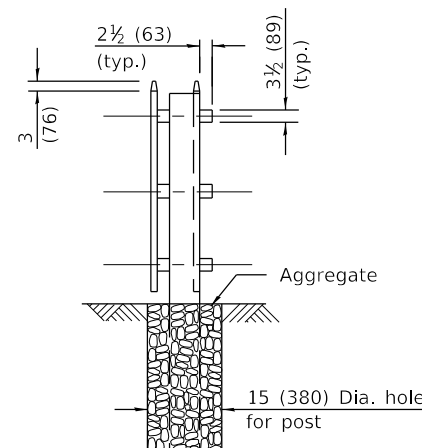

SEC. A-A

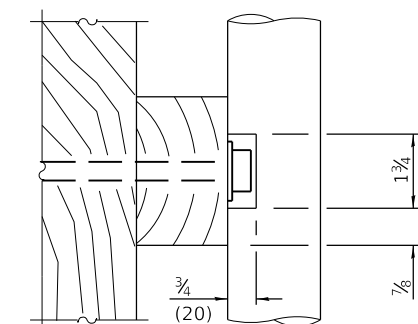

SECTION B-B

(Notch pickets when required to clear washer and bolt head.)

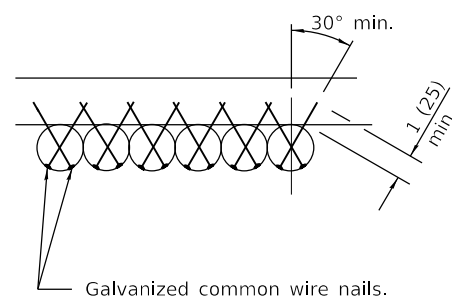

DETAIL A

(Showing typical picket to rail attachment)

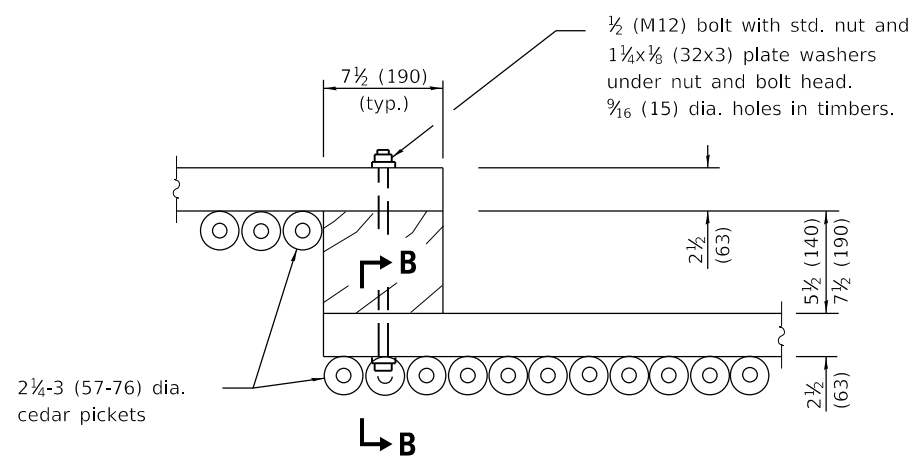

DETAIL B

(Showing typical panel to post connection at each rail.)

GENERAL NOTES

Loading is based on 80 mph (130 km/h) with 30% gust factor. Minimum allowable soil pressure = 1.25 tsf (120 kPa).

All dimensions are in inches (millimeters) unless otherwise shown.

DATE	REVISIONS
1-1-09	Switched units to English (metric). Changed Sec. B-B to Detail B.
1-1-97	Renum. Standard 2367-3.
	Deleted DN Symbol.

**SIGHT SCREEN
CEDAR STOCKADE FENCE
TYPE S**

STANDARD 641001-01

Illinois Department of Transportation

APPROVED January 1, 2009
Ralph E. Anderson
ENGINEER OF BRIDGES AND STRUCTURES

APPROVED January 1, 2009
Lee E. Han
ENGINEER OF DESIGN AND ENVIRONMENT

ISSUED 1-1-97

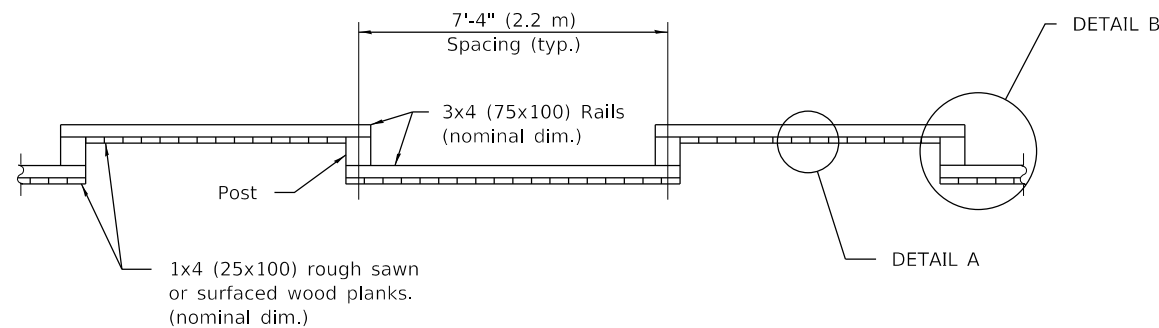

PLAN
(Facing highway)

	FENCE HEIGHT	
	6'-0" (1.8 m)	8'-0" (2.4 m)
Post Size (nominal dim.)	6x8 (150x200)	8x8 (200x200)
Post Length	10'-0" (3.0 m)	14'-0" (4.3 m)
Post Embedment	4'-0" (1.2 m)	6'-0" (1.8 m)
A	15 (380)	18 (460)
B	24 (600)	33 (870)
C	24 (600)	33 (870)
D	12 (300)	15 (380)

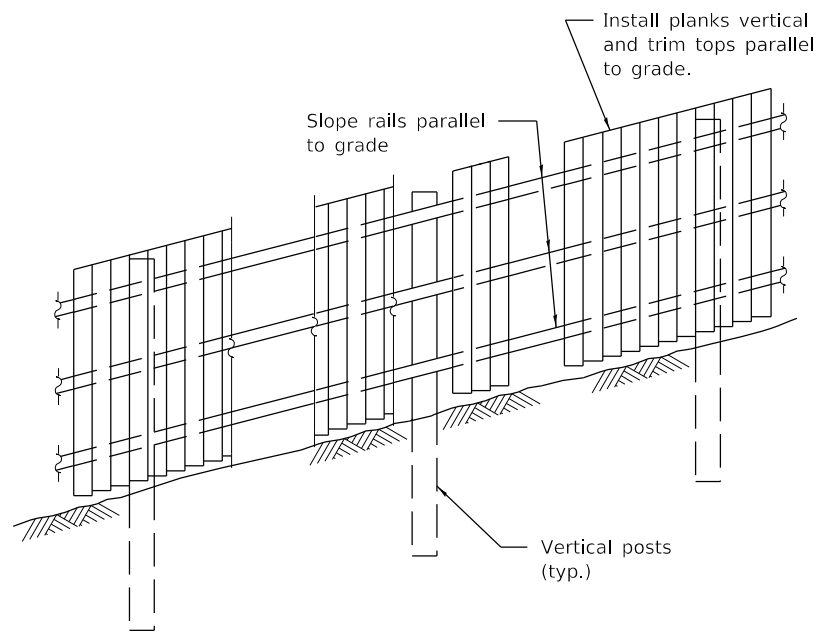

ELEVATION
(Showing treatment with sloping ground)

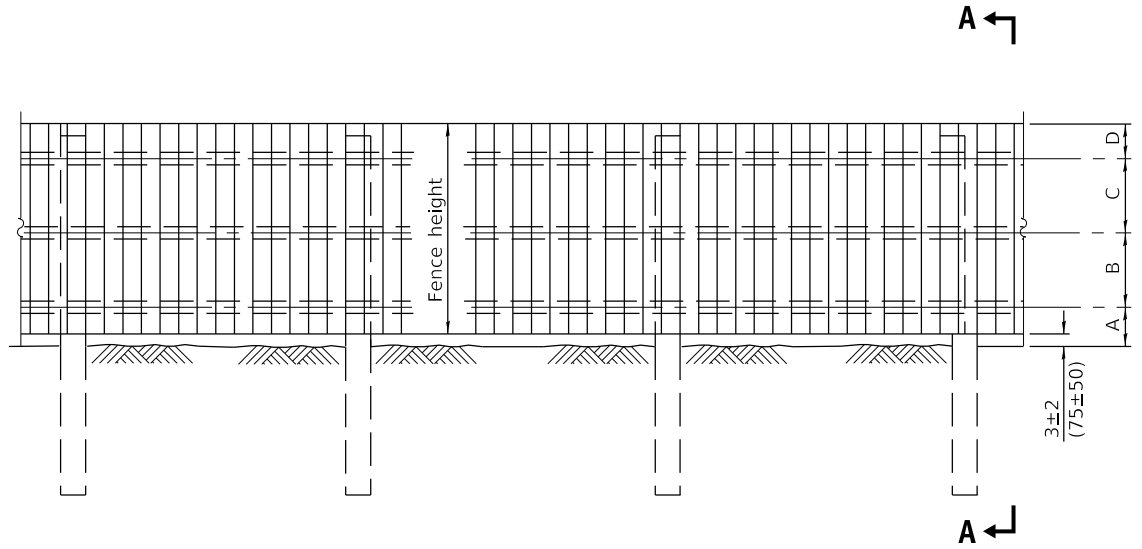

ELEVATION

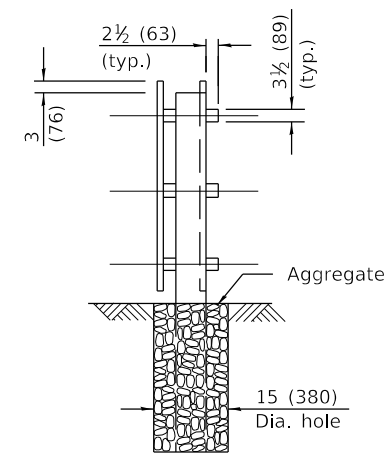

SEC. A-A

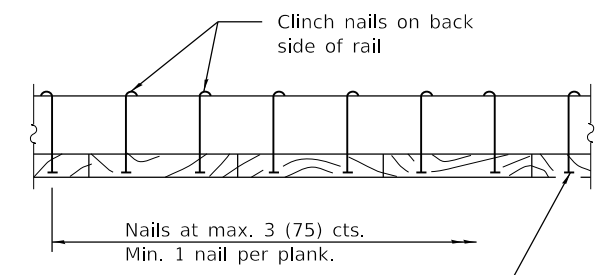

DETAIL A
(Showing typical plank to rail attachment each rail.)

Galvanized common wire nails of sufficient length to have a minimum 1/2 (13) projection to clinch nails in back.

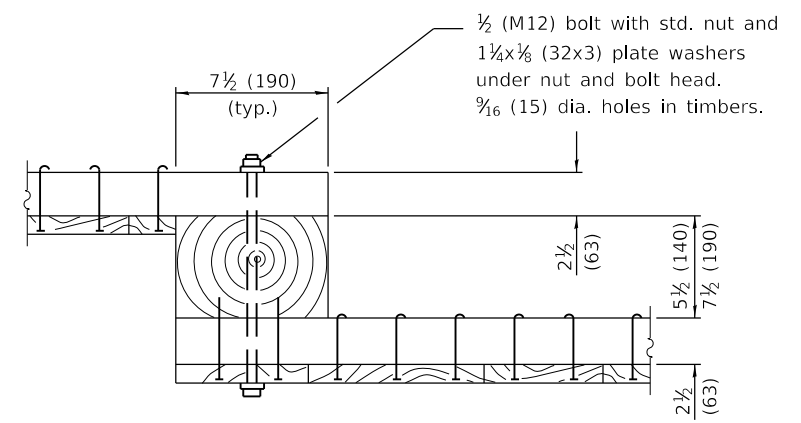

DETAIL B
(Showing typical panel to post connection details)

GENERAL NOTES

Loading was based on 80 mph (130 km/h) with 30% gust factor. Minimum allowable soil pressure = 1.25 tsf (120 kPa).

All dimensions are in inches (millimeters) unless otherwise shown.

DATE	REVISIONS
1-1-09	Switched units to English (metric). Changed Section B-B to Detail B.
1-1-97	Renum. Standard 2367-3. Deleted DN Symbol.

**SIGHT SCREEN
WOOD PLANK FENCE
TYPE P**

STANDARD 641006-01

Illinois Department of Transportation

APPROVED January 1, 2009
Ralph E. Anderson
ENGINEER OF BRIDGES AND STRUCTURES

APPROVED January 1, 2009
Lee E. Han
ENGINEER OF DESIGN AND ENVIRONMENT

ISSUED 1-1-97

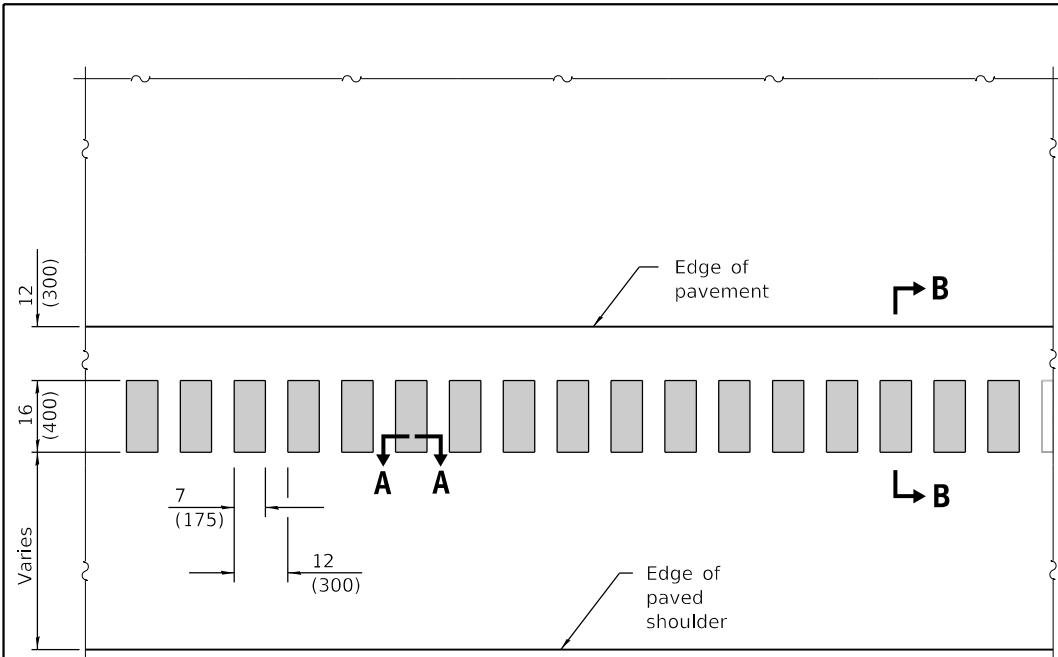

PLAN

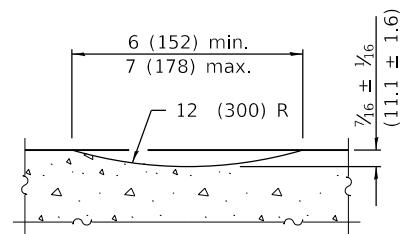

SECTION A-A

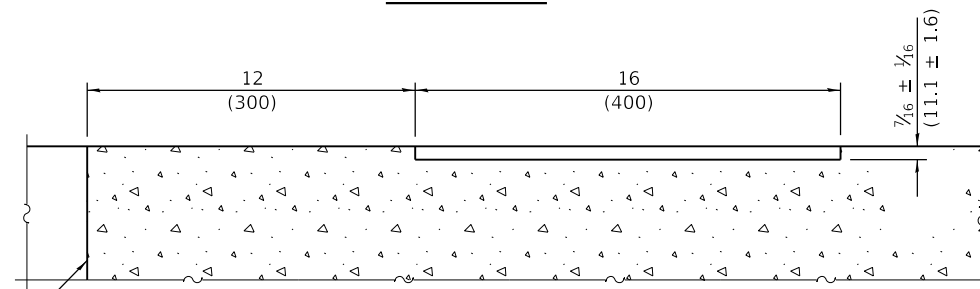

SECTION B-B

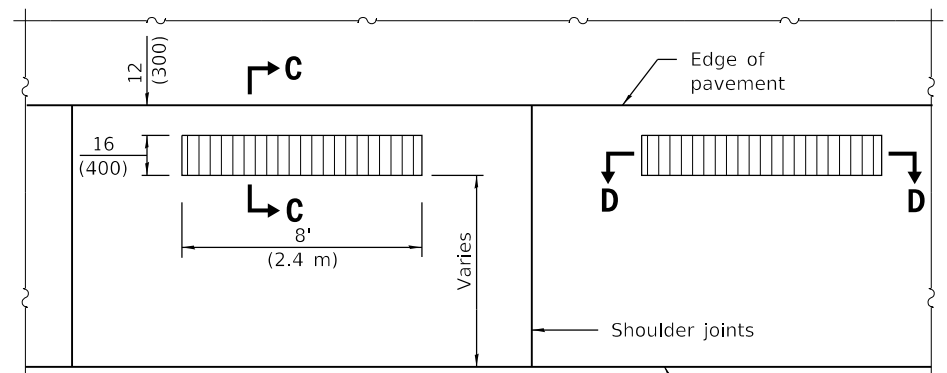

PLAN

(Formed Alternate for PCC Shoulders)
Center rumblestrips between the shoulder joints.

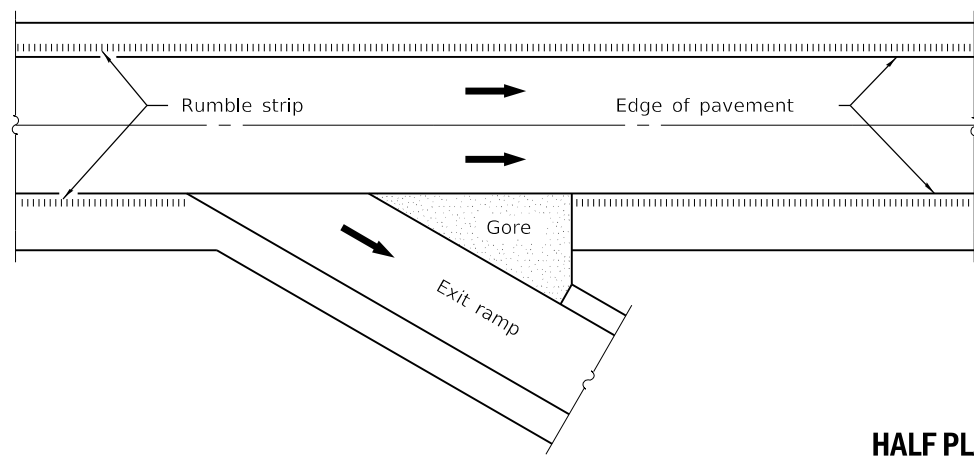

HALF PLAN
TYPICAL APPLICATION AT AN INTERCHANGE

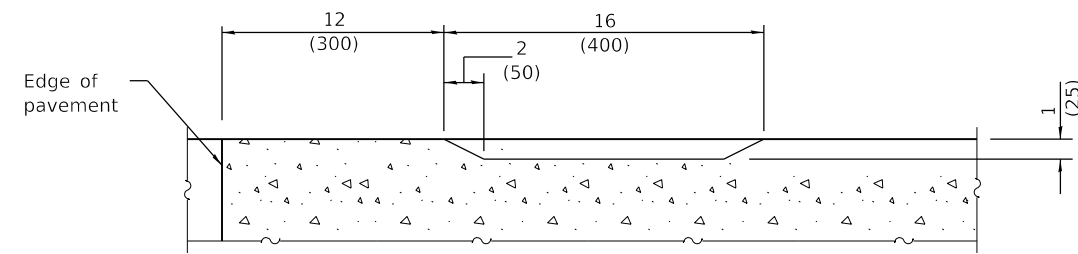
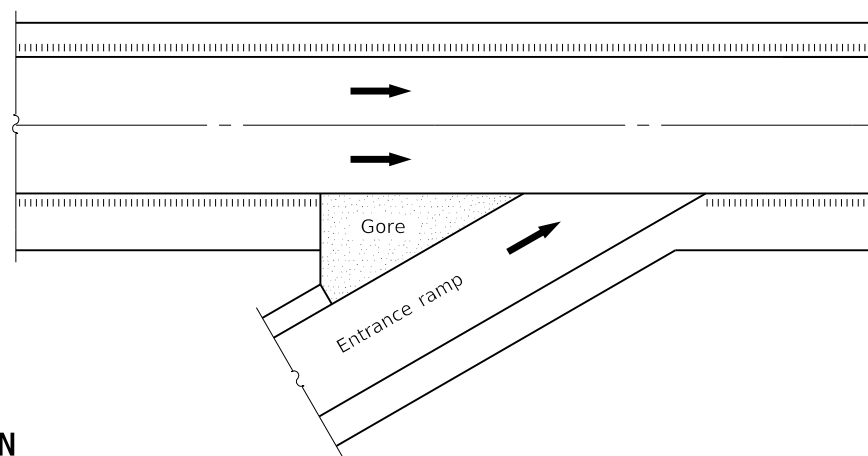

SECTION C-C

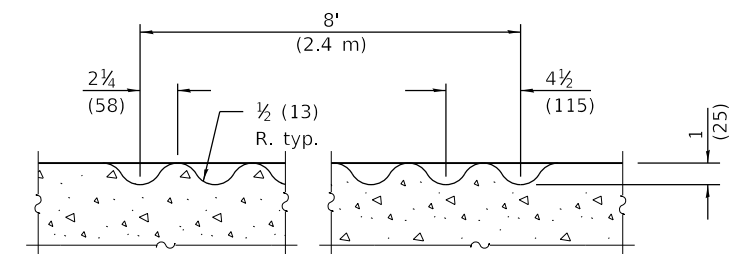

SECTION D-D

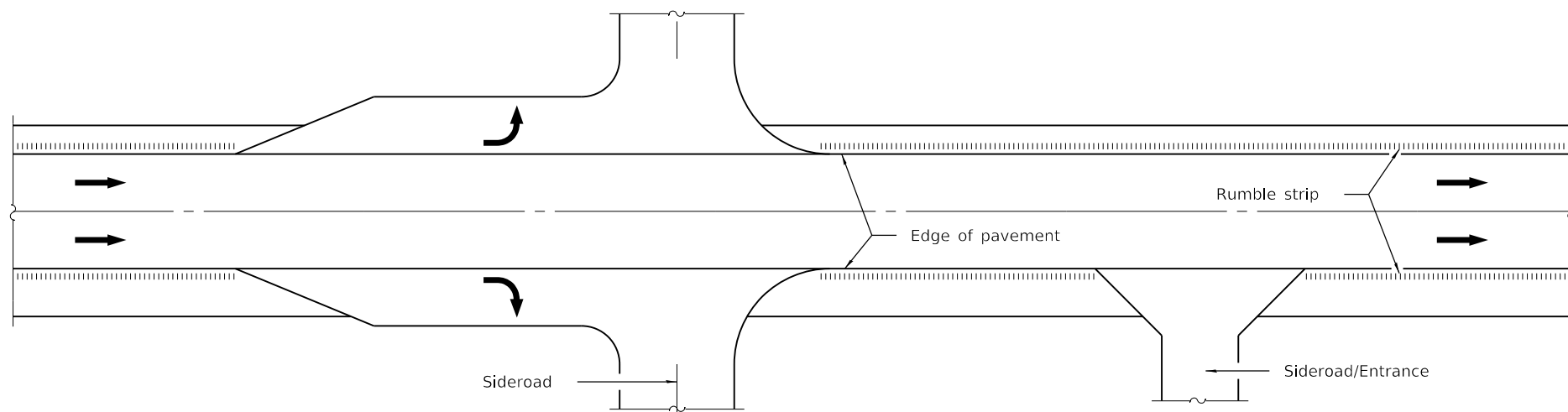

HALF PLAN
TYPICAL APPLICATION AT AN INTERSECTION OR ENTRANCE

GENERAL NOTES

On Portland cement concrete shoulders, no shoulder rumble strip shall be located closer than 6 (150) to a transverse joint.

Omit shoulder rumble strips across structures.

All dimensions are in inches (millimeters) unless otherwise shown.

DATE	REVISIONS
1-1-22	Revised location of rumbles relative to the shoulder joints in Plan View.
1-1-12	Changed formed rumble strip to 16 (400) wide. Rev'd milled strip. Renamed standard.

SHOULDER RUMBLE STRIPS, 16 in.

STANDARD 642001-03

Illinois Department of Transportation

PASSED January 1, 2022
Michael Beard
ENGINEER OF POLICY AND PROCEDURES

APPROVED January 1, 2022
Scott Cline
ENGINEER OF DESIGN AND ENVIRONMENT

ISSUED 1-1-03

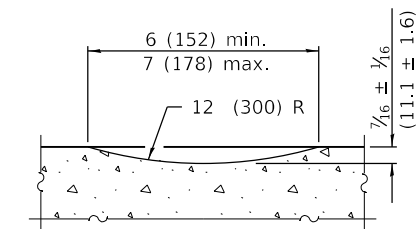
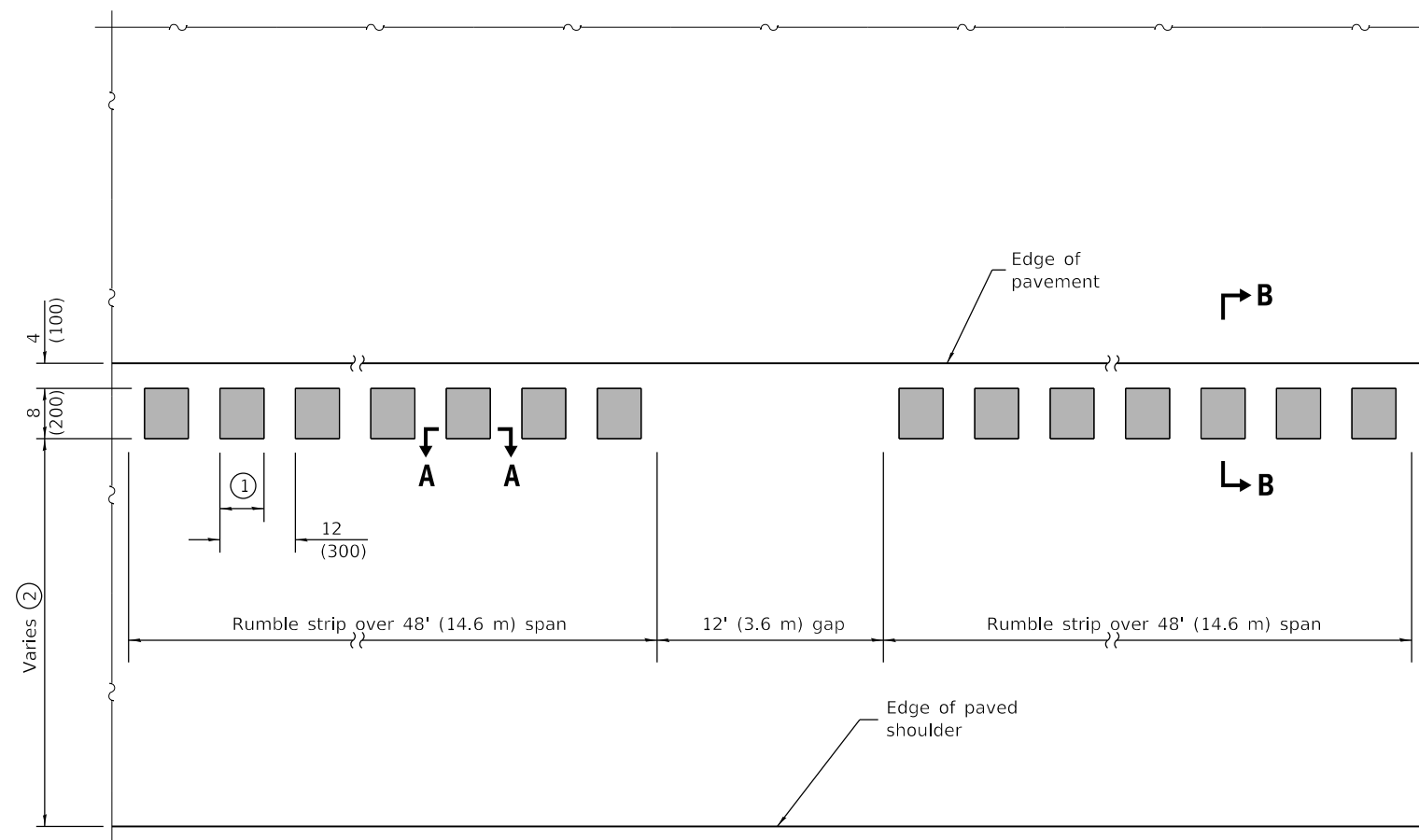

SECTION A-A

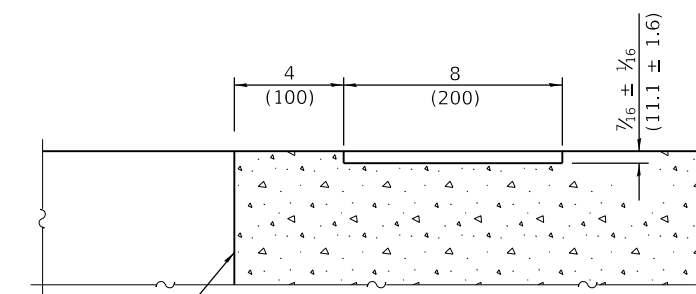

SECTION B-B

- ① See Section A-A.
- ② 4' (1.2 m) preferred, 3' (900) minimum where the paved shoulder is considered a bicycle accommodation.

PLAN

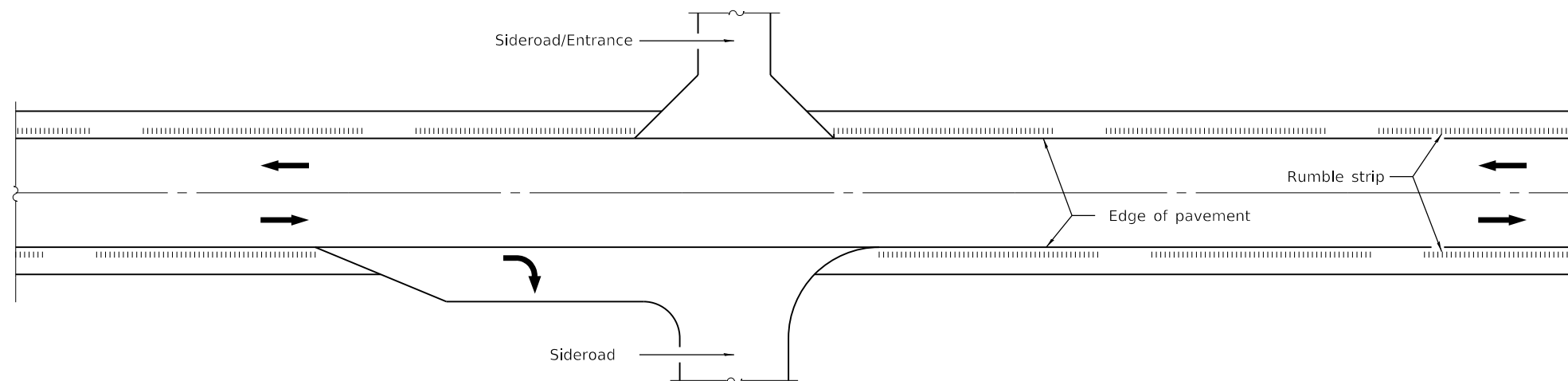

TYPICAL APPLICATION AT AN INTERSECTION OR ENTRANCE

GENERAL NOTES

Omit shoulder rumble strips across structures and at mailbox turnouts.

All dimensions are in inches (millimeters) unless otherwise shown.

DATE	REVISIONS
1-1-21	Added minimum width of paved shoulder for bicycle accommodations.
1-1-12	New standard.

SHOULDER RUMBLE STRIPS, 8 in.

STANDARD 642006-01

Illinois Department of Transportation

PASSED January 1, 2021
Michael Bond
 ENGINEER OF POLICY AND PROCEDURES

APPROVED January 1, 2021
J. E. ...
 ENGINEER OF DESIGN AND ENVIRONMENT

ISSUED 1-1-12

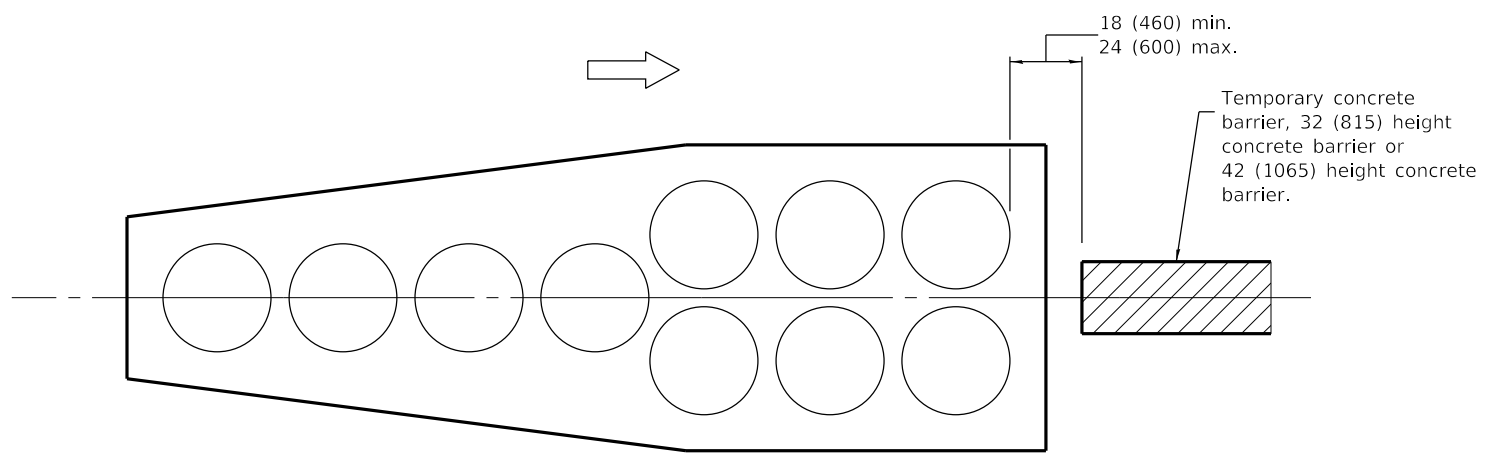

Direction of traffic flow

GORE INSTALLATION
(Traffic approaches on both sides)
(Test Level 2 array shown)

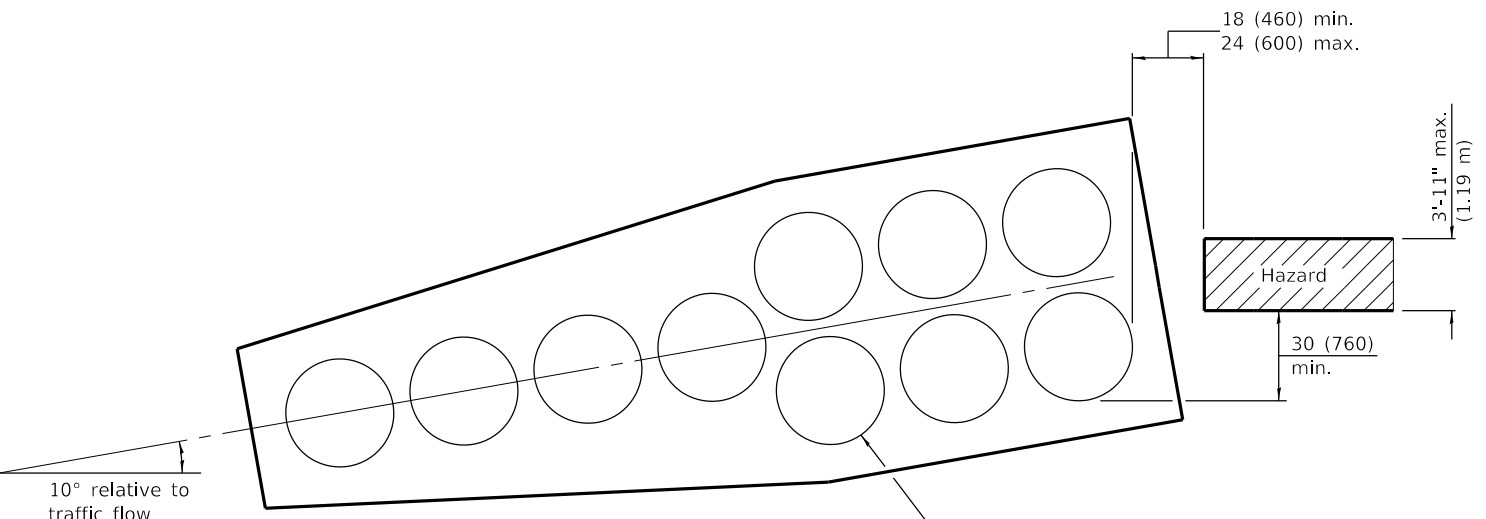

Direction of traffic flow

ROADSIDE INSTALLATION
(Traffic approaches on one side)
(Test Level 2 array shown)

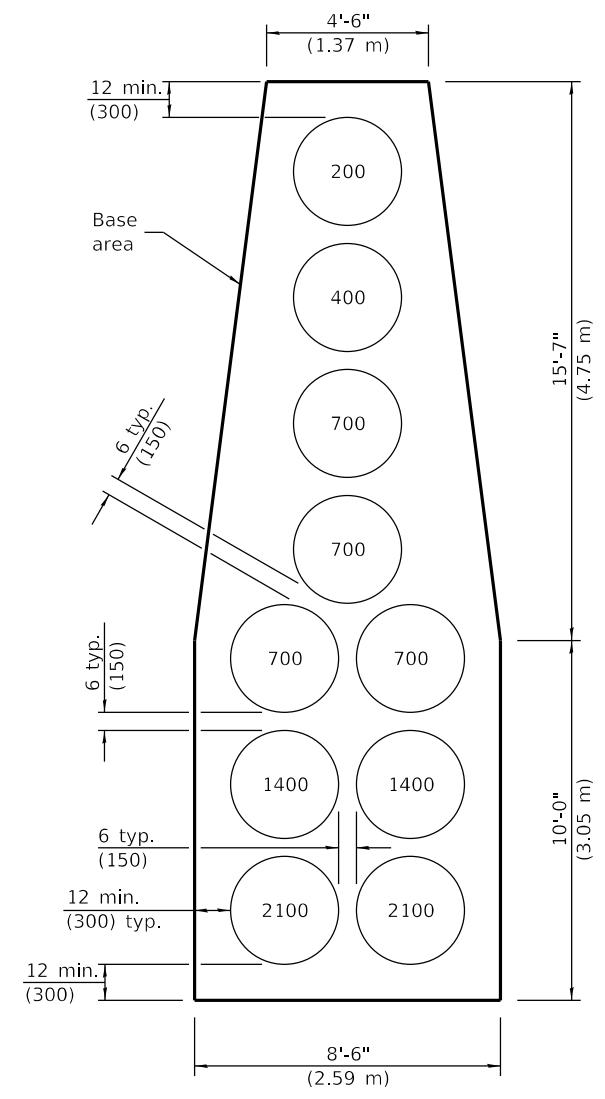

TEST LEVEL 2 ARRAY
(For design speed less than or equal to 45 mph.)
(Numbers inside sand modules indicate sand weight in pounds.)

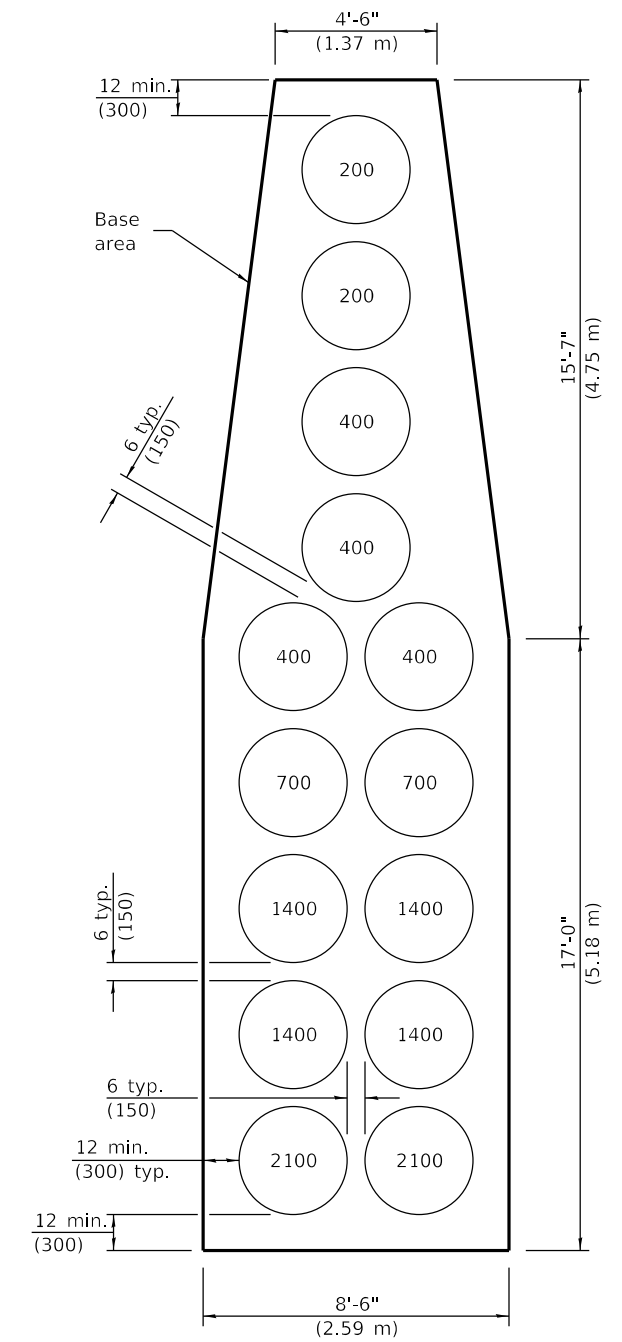

TEST LEVEL 3 ARRAY
(For design speed greater than 45 mph.)
(Numbers inside sand modules indicate sand weight in pounds.)

GENERAL NOTES
All dimensions are in inches (millimeters) unless otherwise shown.

DATE	REVISIONS
1-1-14	Revised distance from barrels to hazard.
1-1-13	Changed 'posted speed' to 'design speed'.

**SAND MODULE
IMPACT ATTENUATORS**

STANDARD 643001-02

Illinois Department of Transportation

PASSED January 1, 2014
Michael Beard
ENGINEER OF POLICY AND PROCEDURES

APPROVED January 1, 2014
[Signature]
ENGINEER OF DESIGN AND ENVIRONMENT

ISSUED 1-1-97

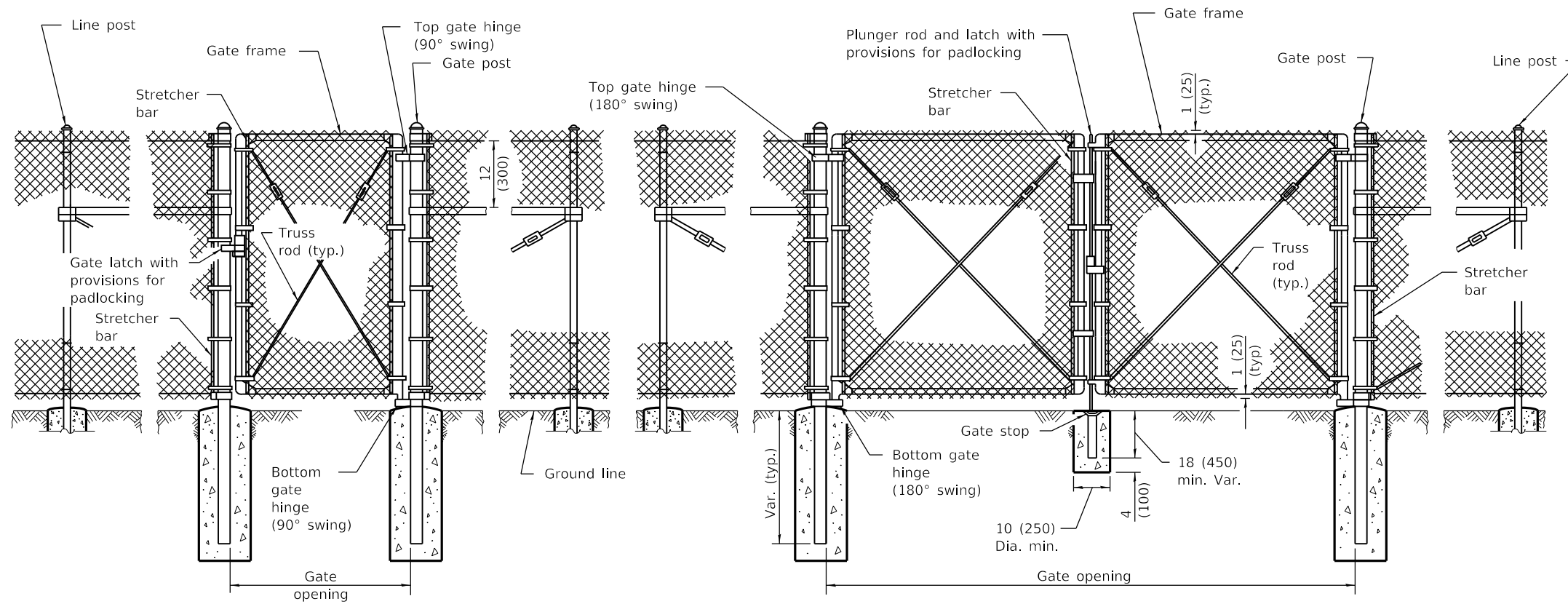

PEDESTRIAN GATE ARRANGEMENT

VEHICLE GATE ARRANGEMENT

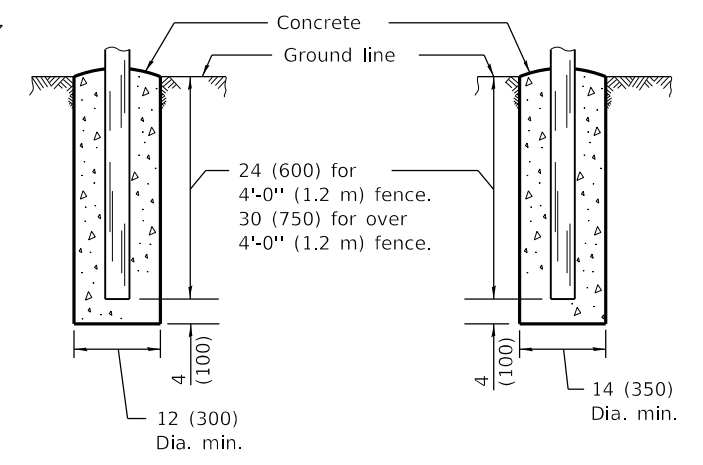

FOOTING FOR LINE POST

FOOTING FOR GATE & TERMINAL POST

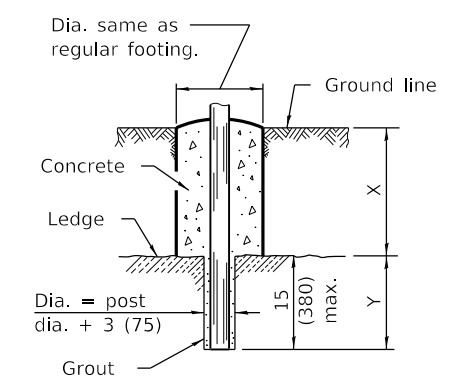

FOOTING FOR POST IN ROCK LEDGE

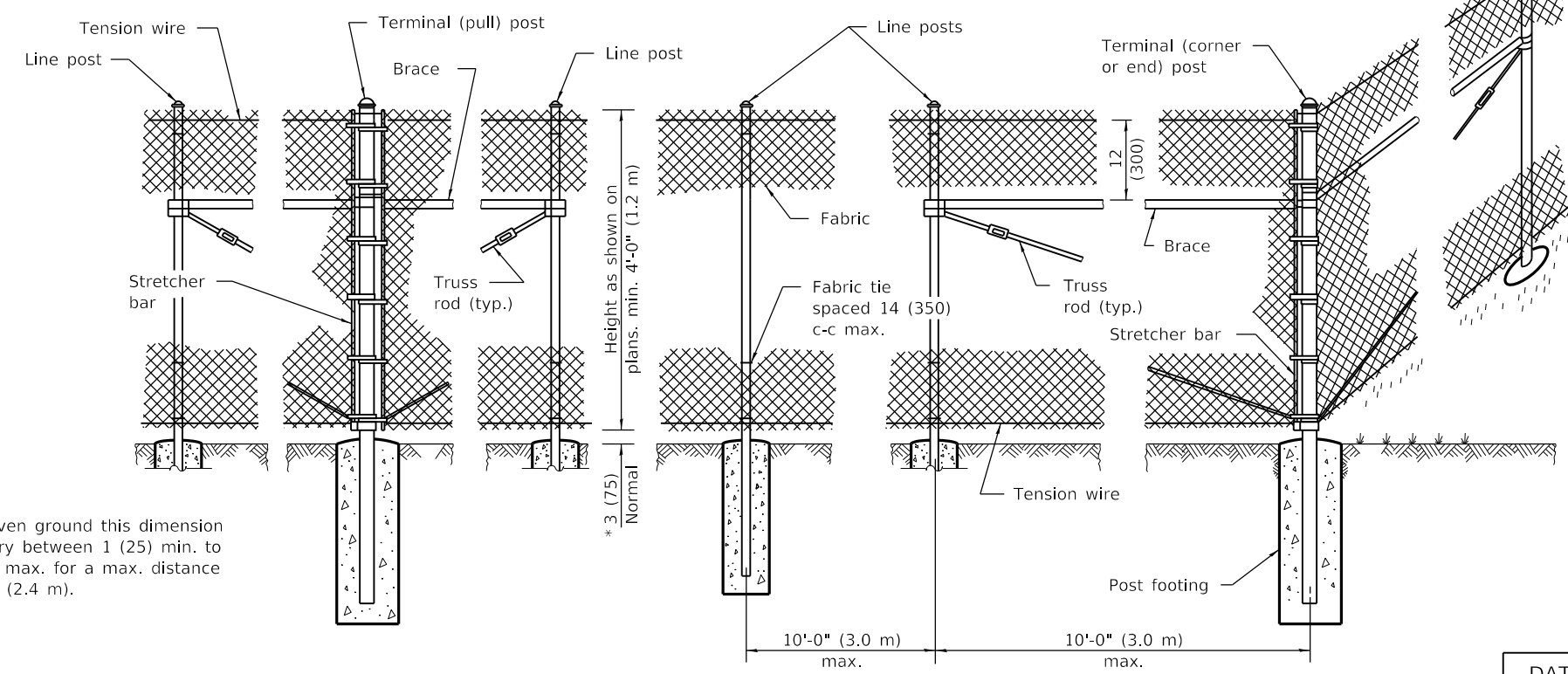

PULL POST ARRANGEMENT

LINE POST ARRANGEMENT

CORNER OR END POST ARRANGEMENT

* On uneven ground this dimension may vary between 1 (25) min. to 5 (125) max. for a max. distance of 8'-0" (2.4 m).

GENERAL NOTES
 Pull posts shall be placed at locations determined by the Engineer. They shall be placed at 660' (200 m) intervals between posts to which the ends of the fabric are clamped or midway between such posts when the distance is less than 1320' (400 m) and greater than 660' (200 m).
 X + Y shall not exceed 24 (600), 30 (750), or 36 (900), as applicable. When X is 0 - 9 (0 - 225), 15 (380), or 21 (525), then Y = 15 (375) and the post shall be shortened as required. When X exceeds 9 (225), 15 (380), or 21 (525), then Y shall be decreased correspondingly.

All dimensions are in inches (millimeters) unless otherwise shown.

Illinois Department of Transportation

PASSED January 1, 2009

ENGINEER OF POLICY AND PROCEDURES

APPROVED January 1, 2009

ENGINEER OF DESIGN AND ENVIRONMENT

ISSUED 1-1-97

DATE	REVISIONS
1-1-09	Switched units to English (metric).
1-1-99	Rev. "pans" to "plans" in LINE POST ARRANGEMENT.

CHAIN LINK FENCE

(Sheet 1 of 3)

STANDARD 664001-02

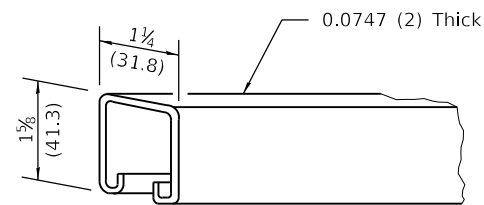

ROLL FORMED SECTION OF BRACE

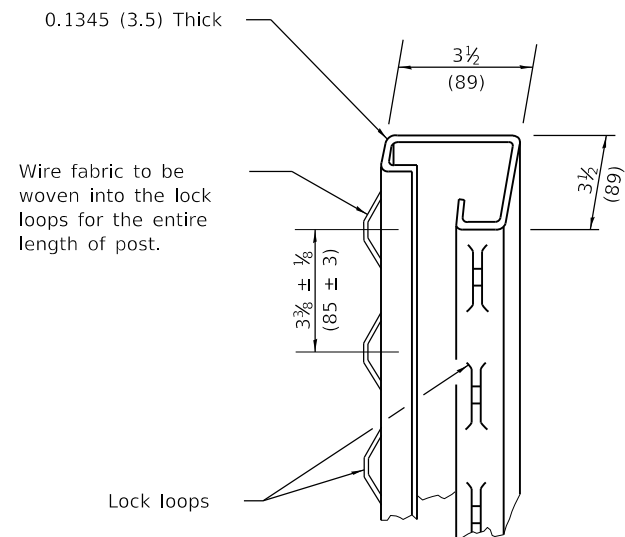

ROLL FORMED SECTION OF TERMINAL & GATE POST

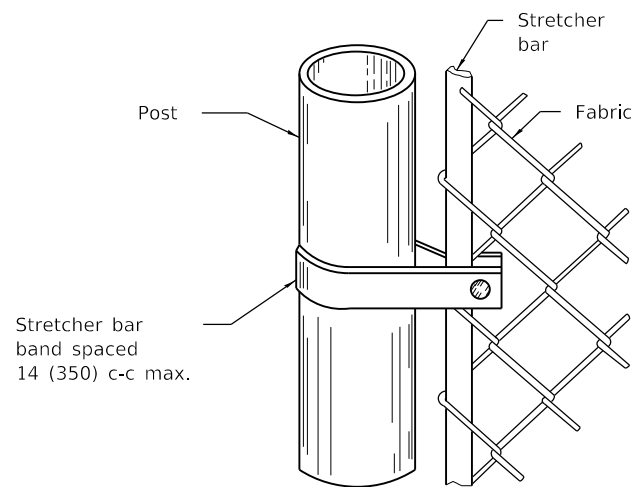

METHOD OF FASTENING STRETCHER BAR TO POST

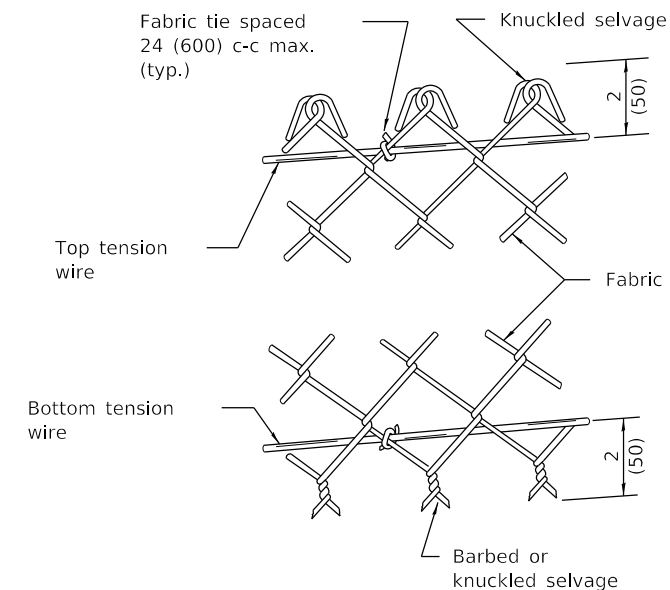

METHOD OF TYING FABRIC TO TENSION WIRES

LINE POST	
Section	lbs./ft. (kg/m)
Pipe Type A 1.90 (48.3) O.D.	2.72 (4.05)
Pipe Type B 1.90 (48.3) O.D.	2.28 (3.39)
Pipe Type C 1.90 (48.3) O.D.	2.26 (3.36)
H 1.875x1.625 (47.6x41.3)	2.72 (4.05)
□	1.60 (2.38)
I	2.30 (3.42)

TERMINAL POST	
Section	lbs./ft. (kg/m)
Pipe Type A 2.375 (60.3) O.D.	3.65 (5.43)
Pipe Type B 2.375 (60.3) O.D.	3.11 (4.63)
Pipe Type C 2.375 (60.3) O.D.	3.09 (4.60)
Roll Formed 3 1/2 x 3 1/2 (89.0 x 89.0)	See detail
Sq. Tubing 2 1/2 x 2 1/2 (63.5 x 63.5)	4.32 (6.43)

HORIZONTAL BRACES	
Section	lbs./ft. (kg/m)
Pipe Type A 1.66 (42.2) O.D.	2.27 (3.38)
Pipe Type B 1.66 (42.2) O.D.	1.83 (2.72)
Pipe Type C 1.66 (42.2) O.D.	1.82 (2.71)
H 1.31x1.5 (33.3x38.1)	2.25 (3.35)
Roll Formed 1 3/8 x 1 1/4 (41.3 x 31.8)	See detail

GATE FRAMES	
Section	lbs./ft. (kg/m)
Pipe Type A 1.66 (42.2) O.D.	2.27 (3.38)
Pipe Type B 1.66 (42.2) O.D.	1.83 (2.72)
Pipe Type C 1.66 (42.2) O.D.	1.82 (2.71)

GATE POSTS *							
Gate Opening * ft. (m)		Pipe Type A		Sq. Tubing		Pipe Type B	
Single	Double	Size (O.D.)	lbs./ft. (kg/m)	Size	lbs./ft. (kg/m)	Size (O.D.)	kg/m (lbs./ft.)
Up to 4 (1.2)	Up to 8 (2.5)	2.375 (60.3)	3.65 (5.43)	2 1/2 (63.5)	4.32 (6.43)	2.375 (60.3)	3.11 (4.63)
Over 4 (1.2) to 8 (2.5)	Over 8 (2.5) to 16 (5.0)	2.875 (73.0)	5.79 (8.62)	3 (76.2)	5.78 (8.60)	2.875 (73.0)	4.64 (6.91)
Over 8 (2.5) to 12 (3.6)	Over 16 (5.0) to 24 (7.4)	3.5 (89.0)	7.58 (11.28)	3 (76.2)	8.80 (13.10)	3.5 (89)	5.707 (8.49)

* The 3 1/2 x 3 1/2 (89.0 x 89.0) roll formed section as detailed may be used as gate posts for single gate up to 6' (1.8 m) and double gate up to 12' (3.6 m).

Illinois Department of Transportation

PASSED January 1, 2009

ENGINEER OF POLICY AND PROCEDURES

APPROVED January 1, 2009

ENGINEER OF DESIGN AND ENVIRONMENT

ISSUED 1-1-97

CHAIN LINK FENCE

(Sheet 2 of 3)

STANDARD 664001-02

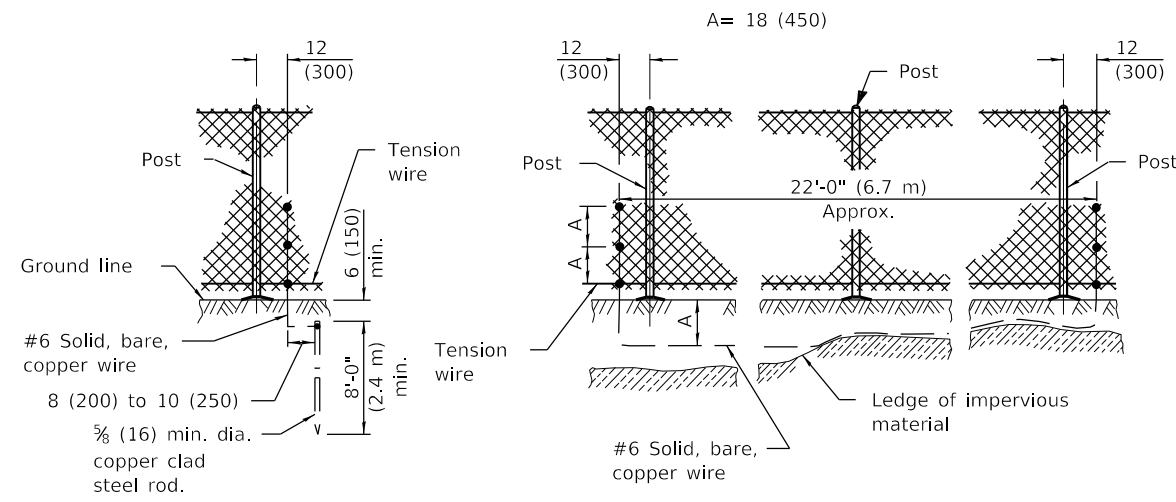

STANDARD GROUND

COUNTERPOISE GROUND (ALTERNATE)

PROTECTIVE ELECTRICAL GROUNDS

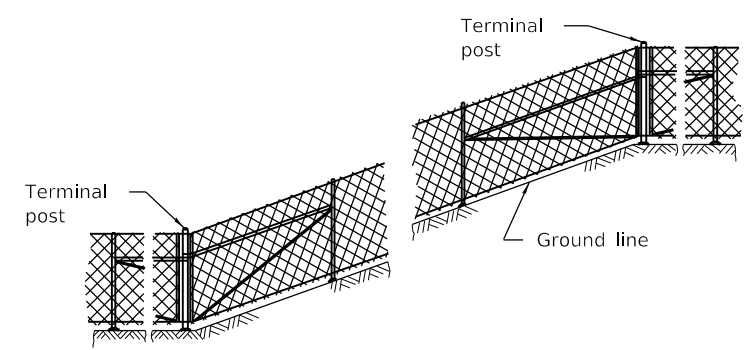

INSTALLATION ON SLOPES

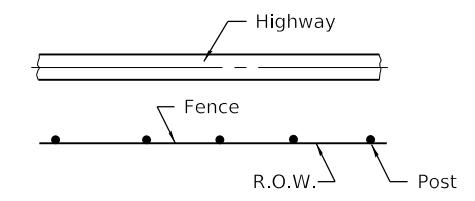

PLAN

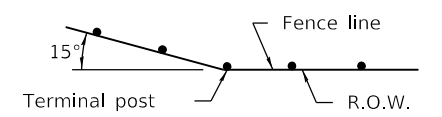

When fence line has a change in direction of 15° or more, a terminal post shall be placed as shown above.

Where angle is less than 15° and existing conditions require a terminal post, they shall be placed as directed by the Engineer.

INSTALLATION AT CORNERS

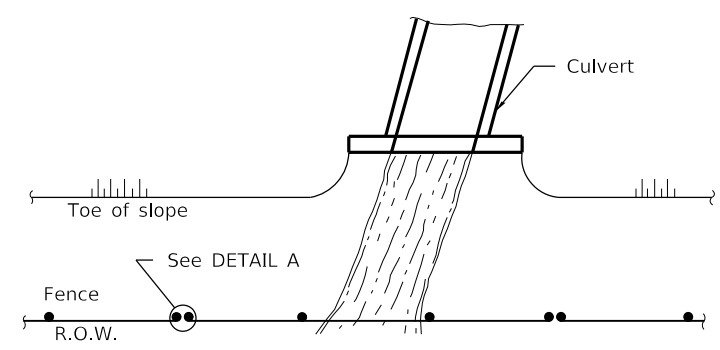

PLAN AT STREAM CROSSING

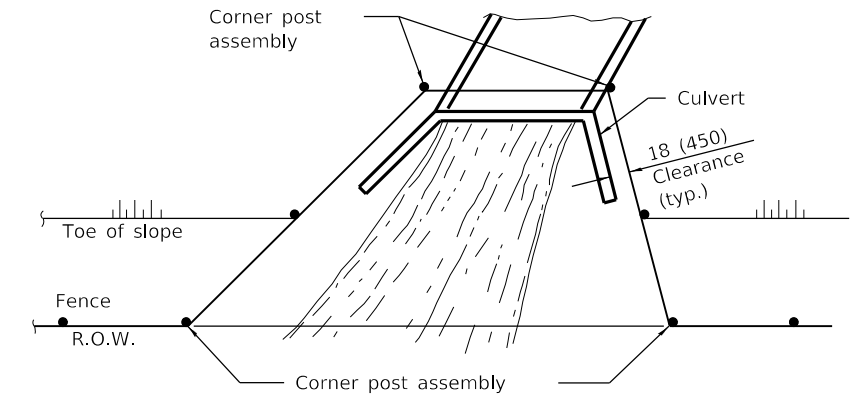

PLAN AT HEADWALL

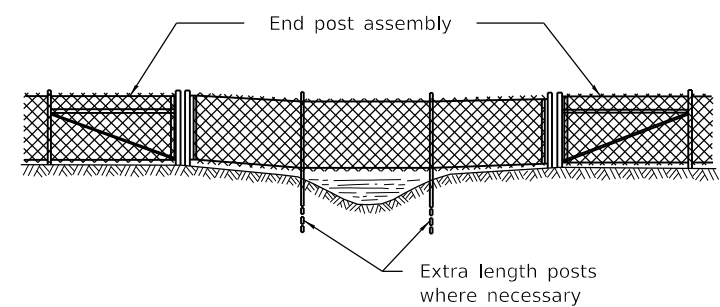

ELEVATION INSTALLATION OVER STREAM

The chain link fabric shall be replaced by barbed wire strands at 12 (300) maximum centers between the double posts shown on DETAIL A when shown on the plans.

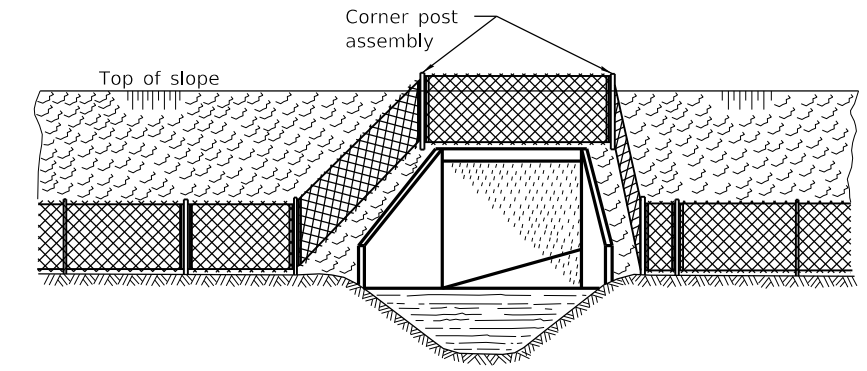

ELEVATION INSTALLATION AROUND HEADWALL

When the width of the culvert makes it necessary to anchor a post to the top of the culvert, a cast iron shoe or other device approved by the Engineer shall be used.

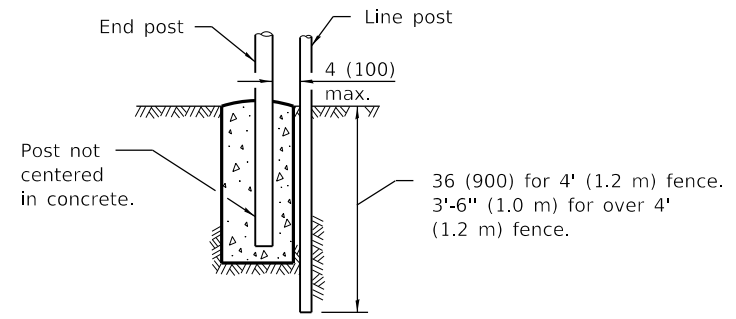

DETAIL A

Illinois Department of Transportation

PASSED January 1, 2009

ENGINEER OF POLICY AND PROCEDURES

APPROVED January 1, 2009

ENGINEER OF DESIGN AND ENVIRONMENT

ISSUED 1-1-97

CHAIN LINK FENCE

(Sheet 3 of 3)

STANDARD 664001-02

FENCE USING METAL POSTS

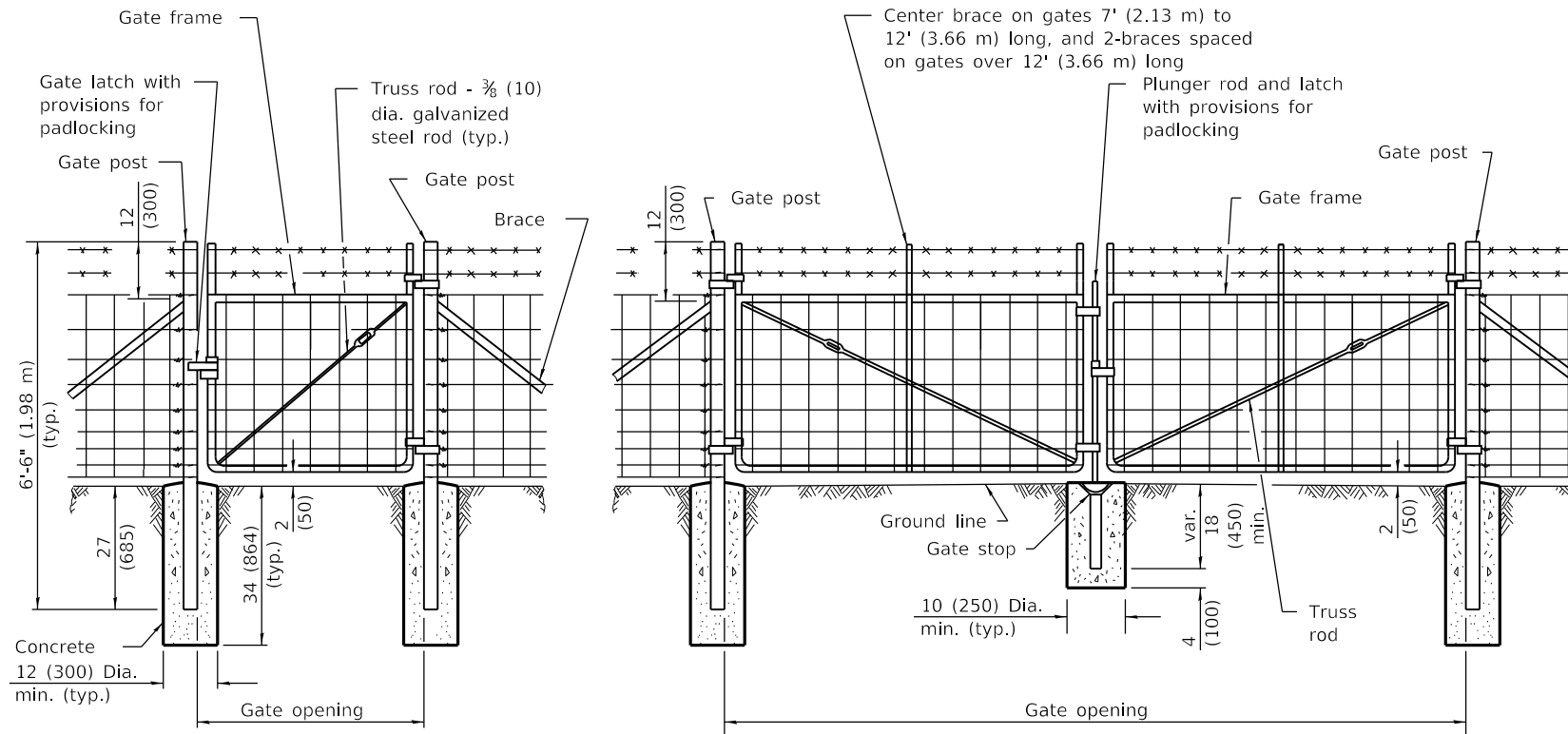

SINGLE GATE

DOUBLE GATE

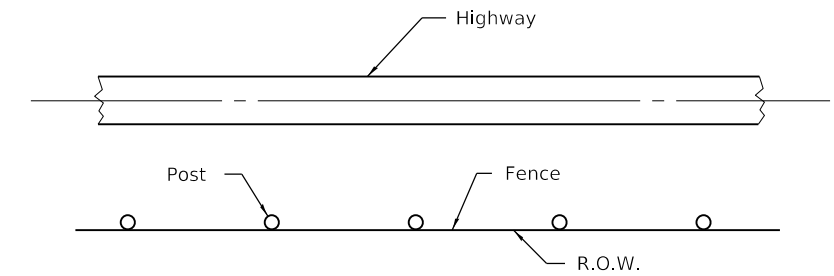

PLAN

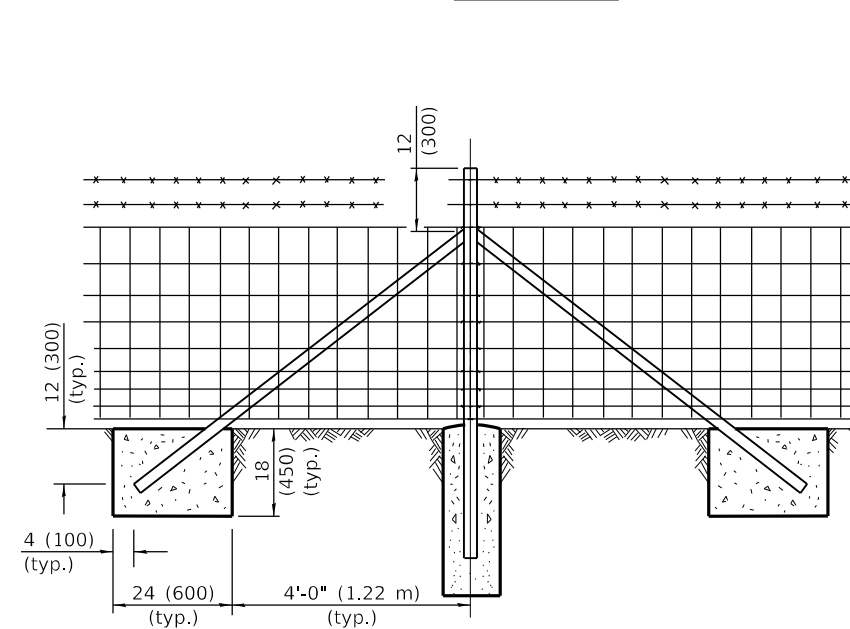

PULL POST

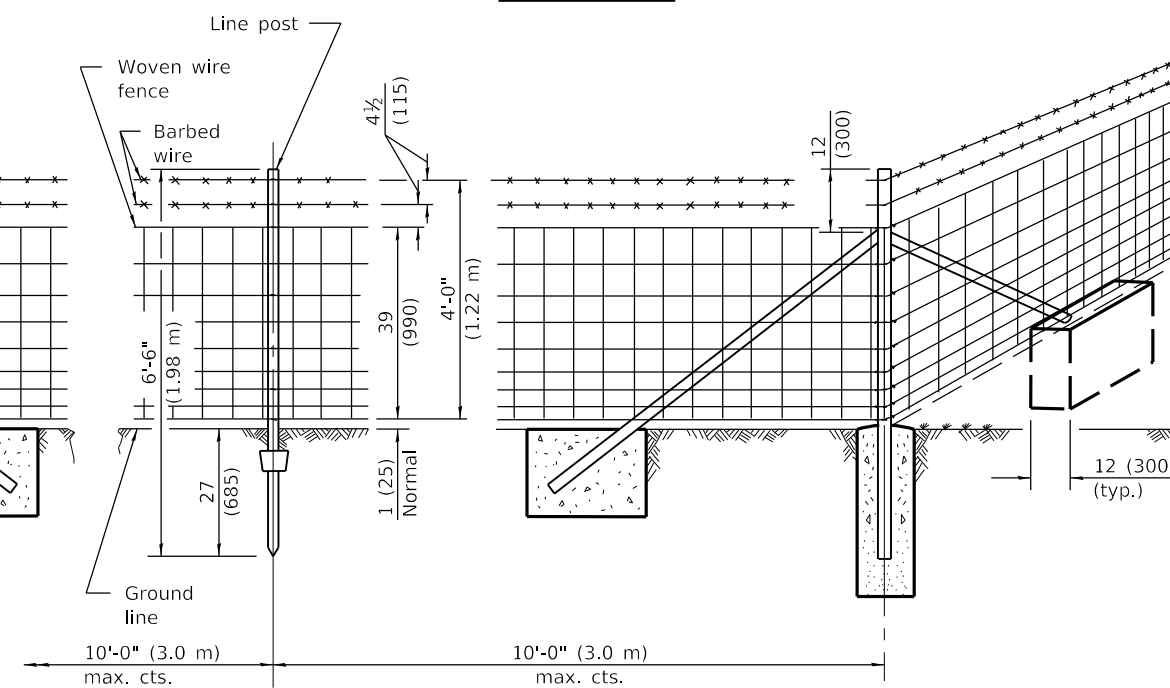

LINE POST

CORNER OR END POST

NOTES

Barbed wires shall be tied to each post. Top and bottom wires of woven fence shall be tied to each post. Tie every other wire between, alternating on successive posts.

Barbed wires and line wires of woven fence shall be fastened to the corner, end, pull, and gate posts by wrapping the wires around the post and tying back on itself with not less than 3 twists tightly wrapped.

GENERAL NOTES

Pull posts shall be placed at the locations determined by the Engineer. They shall be placed at 660' (200 m) intervals between posts to which the ends of the fabric and barbed wires are fastened or midway between such posts when the distance is less than 1320' (400 m) and greater than 660' (200 m).

Bracing for gate posts shall be the same type used for end posts.

The clearance between the bottom fence wire and the ground may be up to 3 (75) for a maximum distance of 8' (2.4 m) when uneven ground is encountered.

All dimensions are in inches (millimeters) unless otherwise shown.

Illinois Department of Transportation

PASSED January 1, 2009

ENGINEER OF POLICY AND PROCEDURES

APPROVED January 1, 2009

ENGINEER OF DESIGN AND ENVIRONMENT

ISSUED 1-1-09

DATE	REVISIONS
1-1-09	Switched units to English (metric).
1-1-02	Corrected dimensions on sheet 3 and 4.

WOVEN WIRE FENCE

(Sheet 1 of 4)

STANDARD 665001-02

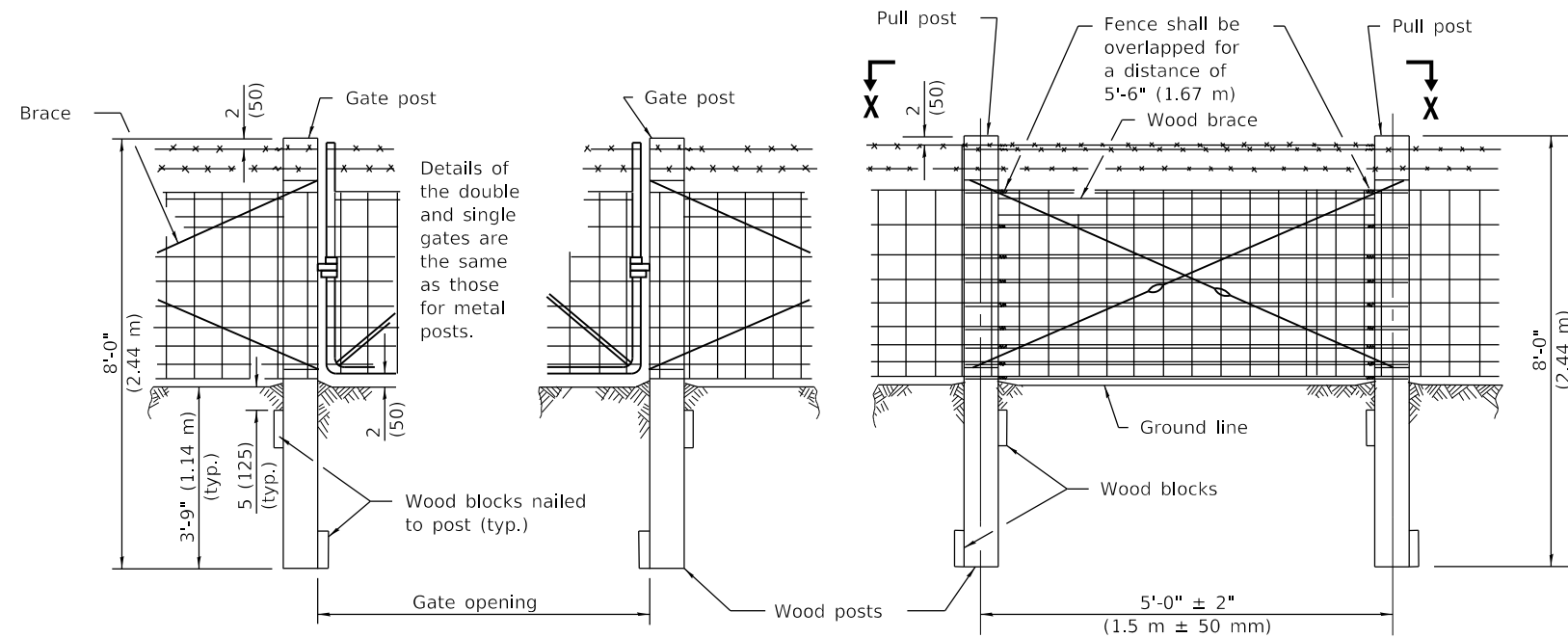

SINGLE OR DOUBLE GATE

PULL POST

SECTION X-X

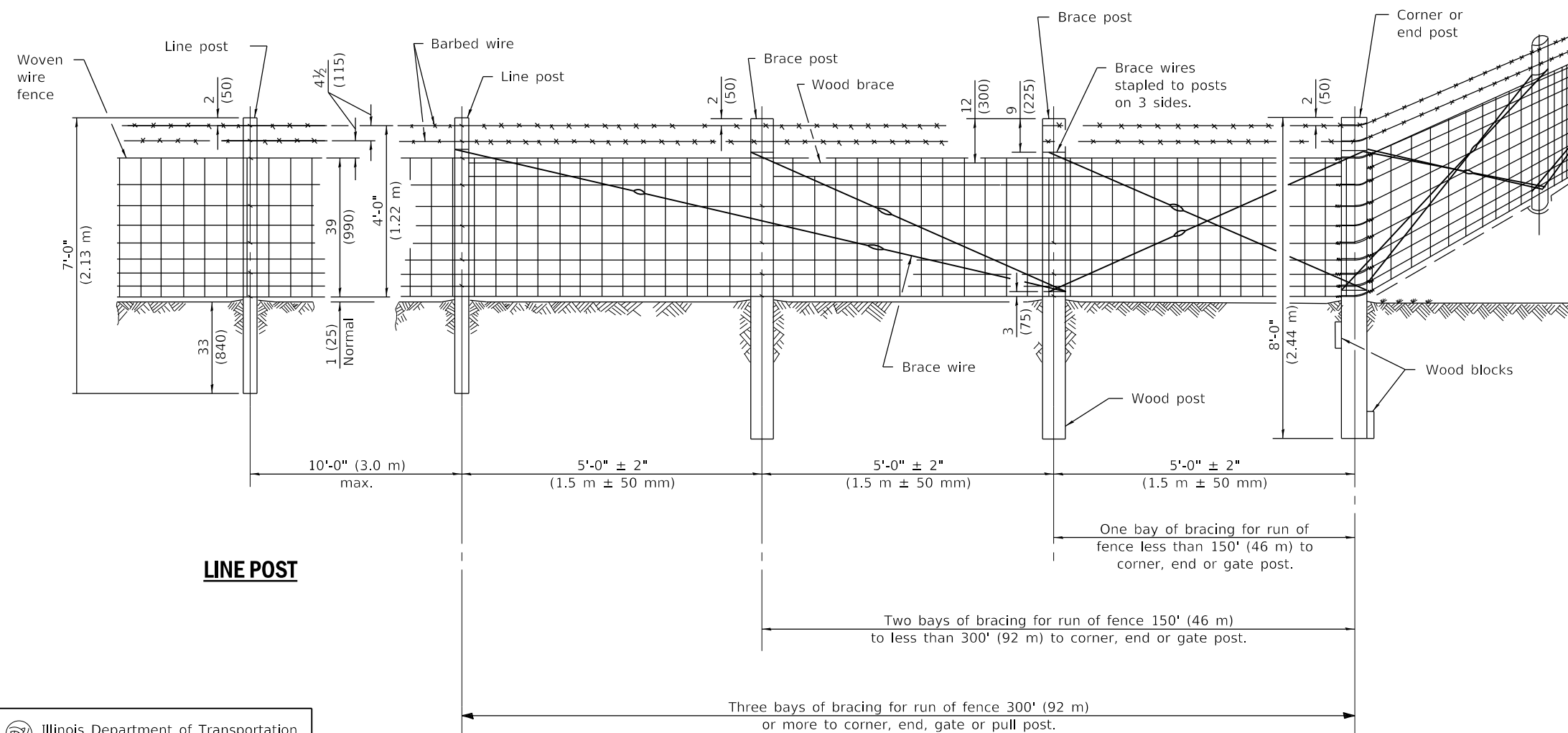

LINE POST

CORNER OR END POST

NOTES

Barbed wires shall be stapled to each post. Top and bottom wire of woven fence shall be stapled to each post. Staple every other wire between, alternating on successive posts.

Metal line posts may be used in lieu of wood line posts.

Illinois Department of Transportation

PASSED January 1, 2009

ENGINEER OF POLICY AND PROCEDURES

APPROVED January 1, 2009

ENGINEER OF DESIGN AND ENVIRONMENT

ISSUES 46-1-1 03/05/11

WOVEN WIRE FENCE

(Sheet 2 of 4)

STANDARD 665001-02

METAL ITEMS

GATE FRAMES		CORNER, END or PULL POSTS		LINE POSTS		BRACES	
Section	lbs./ft. (kg/m)	Section	lbs./ft. (kg/m)	Section	lbs./ft. (kg/m)	Section	lbs./ft. (kg/m)
Type A: Pipe 1.66 (42.2) O.D. Type B: Pipe 1.66 (42.2) O.D. Type C: Pipe 1.66 (42.2) O.D.	2.27 (3.38) 1.83 (2.72) 1.82 (2.71)	Type A: Pipe 2.375 (60.3) O.D. Type B: Pipe 2.375 (60.3) O.D. Type C: Pipe 2.375 (60.3) O.D. Tubing 2.5 (63.5) Sq. Angle 2½x2½x¼ (64x64x6.4) H, I, U, structural shapes	3.65 (5.43) 3.11 (4.63) 3.09 (4.60) 4.32 (6.43) 4.1 (6.10) 4.1 (6.10) min.	Type A: Pipe 1.315 (33.4) O.D. Type B: Pipe 1.315 (33.4) O.D. Type C: Pipe 1.315 (33.4) O.D. Tubing 1 (25.4) Sq. L, C, T, U, Y or other approved structural shapes	1.68 (2.50) 1.34 (1.99) 1.33 (1.98) 1.41 (2.10) 1.33 (1.98) min.	Type A: Pipe 1.66 (42.2) O.D. Type B: Pipe 1.66 (42.2) O.D. Type C: Pipe 1.66 (42.2) O.D. Angle 2½x2½x¼ (64x64x6.4) or other approved structural shapes	2.27 (3.38) 1.83 (2.72) 1.82 (2.71) 3.19 (4.75) 3.1 (4.61) min.

METAL ITEMS

GATE POSTS					
Single gate up to 4 ft. (1.22 m) Double gate up to 8 ft. (2.44 m)		over 4 ft. to 8 ft. (1.22 m to 2.44 m) over 8 ft. to 16 ft. (2.44 m to 4.88 m)		over 8 ft. to 12 ft. (2.44 m to 3.66 m) over 16 ft. to 24 ft. (4.88 m to 7.32 m)	
Section	lbs./ft. (kg/m)	Section	lbs./ft. (kg/m)	Section	lbs./ft. (kg/m)
Type A: Pipe 2.375 (60.3) O.D. Type B: Pipe 2.375 (60.3) O.D. Type C: Pipe 2.375 (60.3) O.D. Tubing 2.5 (63.5) Sq. Angle 2½x2½x¼ (64x64x6.4) H, I, U, structural shapes	3.65 (5.43) 3.11 (4.63) 3.09 (4.60) 4.32 (6.43) 4.1 (6.10) 4.1 (6.10) min.	2.875 (73.0) O.D. 2.875 (73.0) O.D. 2.875 (73.0) O.D. 3 (76.2) Sq. 3x3x¾ (76x76x7.9)	5.79 (8.62) 4.64 (6.91) 3.78 (5.63) 5.78 (8.60) 6.1 (9.08) 6.1 (9.08) min.	3.500 (88.9) O.D. 3 (76.2) Sq. 3½x3½x¾ (76x76x9.5)	7.58 (11.28) 8.80 (31.10) 8.5 (10.70) 8.5 (10.70) min.

WOOD ITEMS

(S4S or Rough Sawn)

GATE, CORNER, END or PULL POSTS	BRACES and LINE POSTS	BLOCKS
6 to 7 (150 to 175) Top dia. 6x6 (150x150)	4 to 5 (100 to 125) Top dia. 4x4 (100x100)	2x8x18 (50x200x450)

Illinois Department of Transportation

PASSED January 1, 2009

 ENGINEER OF POLICY AND PROCEDURES

APPROVED January 1, 2009

 ENGINEER OF DESIGN AND ENVIRONMENT

ISSUED 1-1-97

WOVEN WIRE FENCE

(Sheet 3 of 4)

STANDARD 665001-02

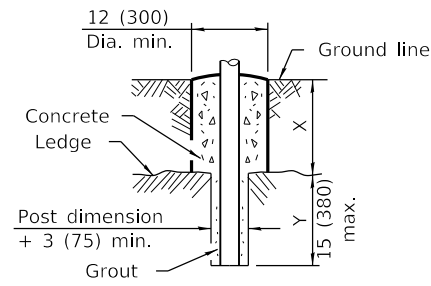

METAL POST

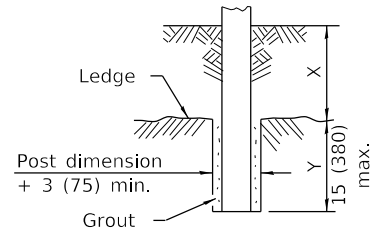

WOOD POST

NOTE
 X + Y shall not exceed 27 (685), 33 (840), or 3'-9" (1.14 m) as applicable. When X is 0 to 12 (300), 18 (450), or 30 (760), Y = 15 (380), and the post shall be shortened as required. When X exceeds 12 (300), 18 (450), or 30 (760), Y shall be decreased correspondingly.

FOOTING FOR POSTS WHEN ROCK LEDGE IS ENCOUNTERED

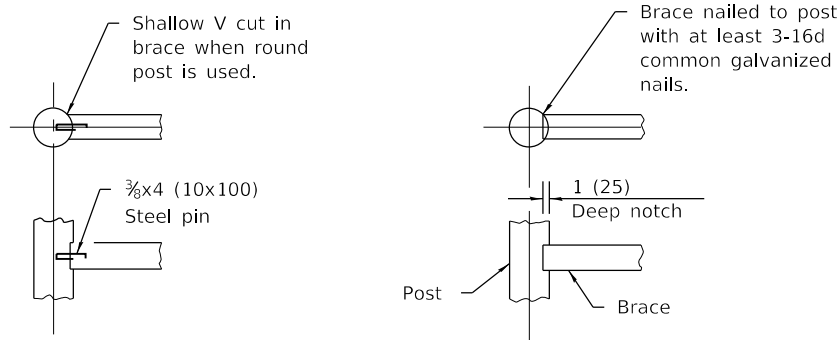

ALTERNATE DETAILS FOR FASTENING WOOD BRACE TO WOOD POST

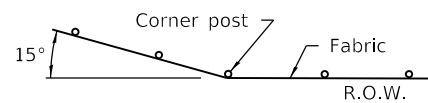

NOTE
 Where fence line has a change in direction of 15° or more, a corner post with bracing as required shall be placed as shown above. Where angle is less than 15° and existing conditions require a corner post, they shall be placed as directed by the Engineer.

INSTALLATION AT CORNERS

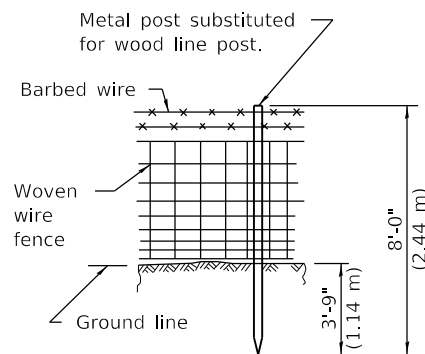

PROTECTIVE ELECTRICAL GROUNDING FOR WOOD POST FENCE INSTALLATION

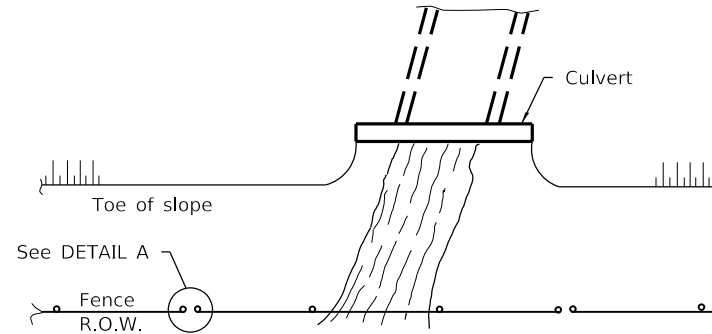

PLAN AT STREAM CROSSING

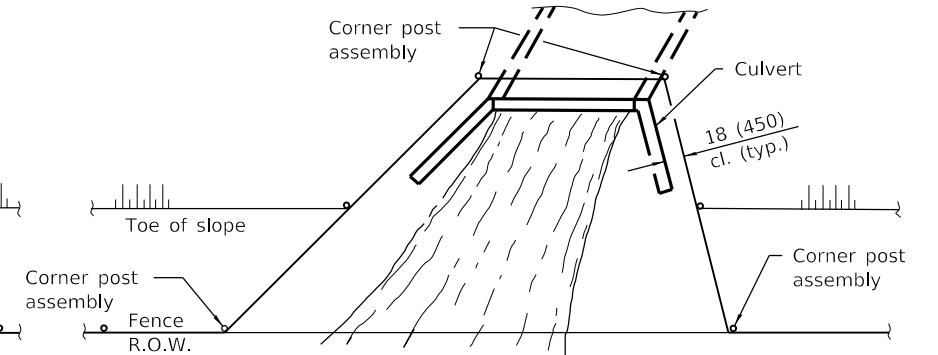

PLAN AT HEADWALL

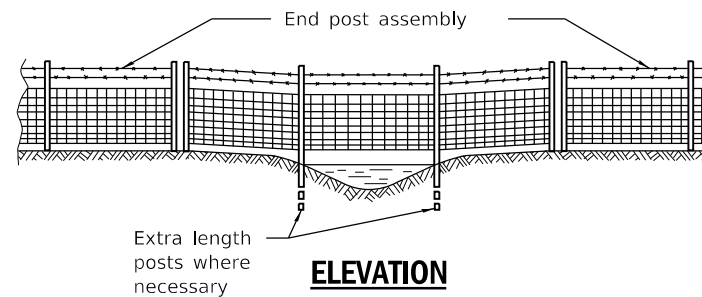

ELEVATION

NOTE
 The woven wire fabric shall be replaced by barbed wire strands at 12 (300) maximum centers between the double posts shown on DETAIL A when shown on the plans.

INSTALLATION OVER STREAM

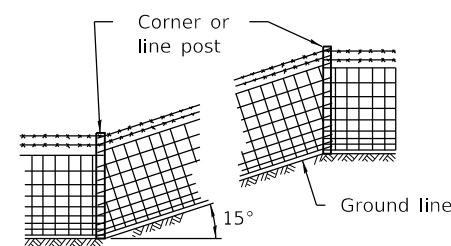

NOTE
 Where grade line has a change in slope of 15° or more, a corner post with bracing as required shall be placed as shown above. Where angle is less than 15° line posts may be used.

When the tension of the fence tends to pull the posts from the ground, the line posts shall be anchored with the applicable concrete or wood anchorage specified for corner posts.

INSTALLATION ON SLOPES

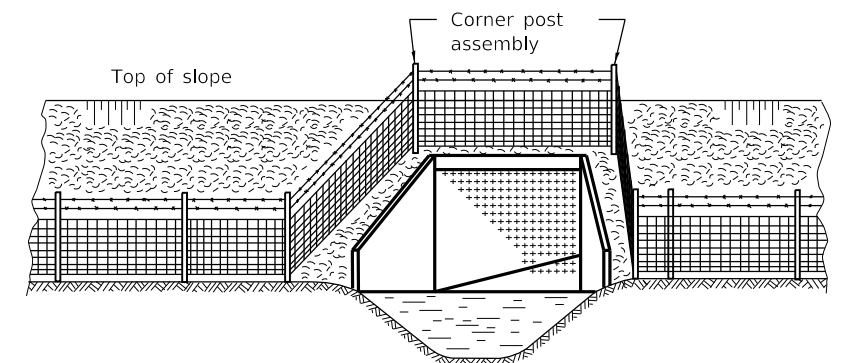

ELEVATION

NOTE
 When the width of the culvert makes it necessary to anchor a post to the top of the culvert, a cast iron shoe or other device approved by the Engineer shall be used.

INSTALLATION AROUND HEADWALL

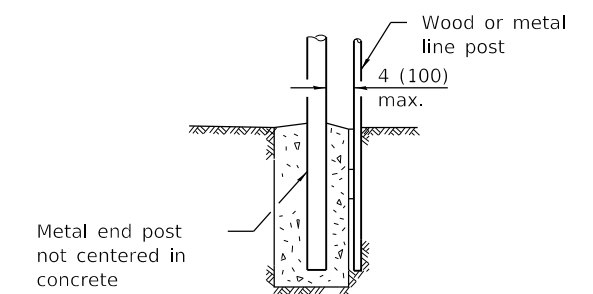

DETAIL A

Illinois Department of Transportation

PASSED January 1, 2009

ENGINEER OF POLICY AND PROCEDURES

APPROVED January 1, 2009

ENGINEER OF DESIGN AND ENVIRONMENT

ISSUED 1-1-97

WOVEN WIRE FENCE

(Sheet 4 of 4)

STANDARD 665001-02

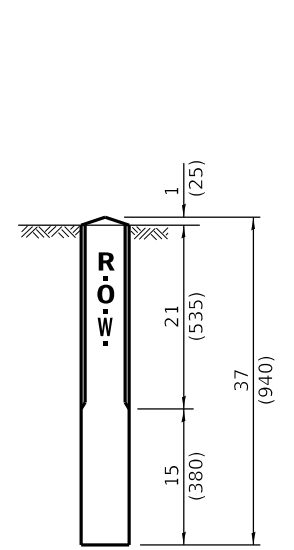
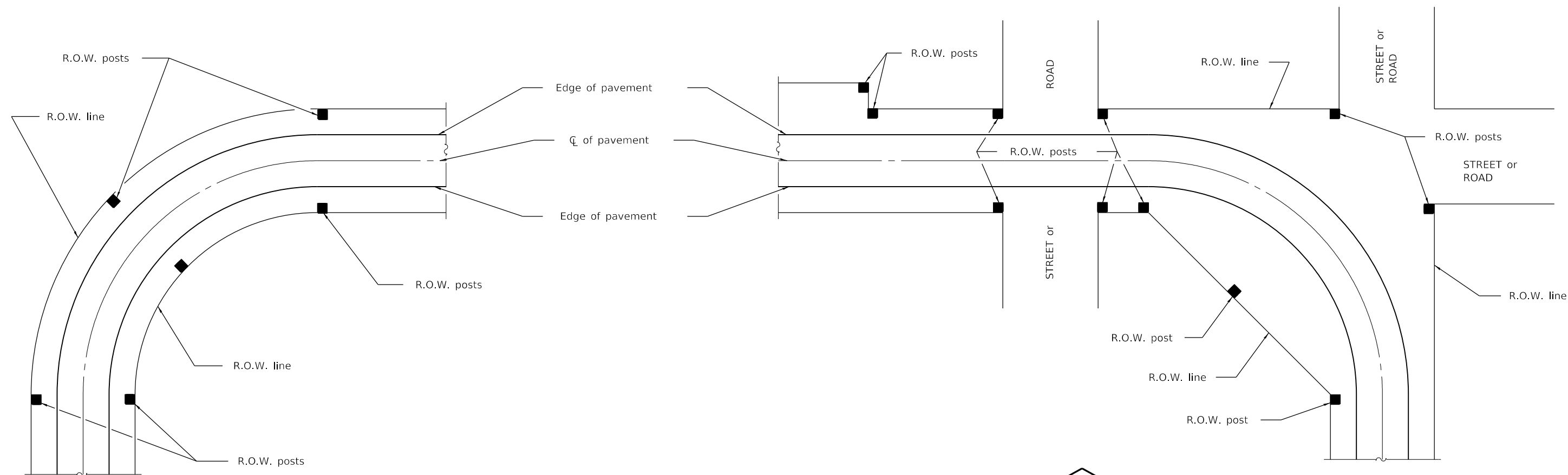

METHOD B

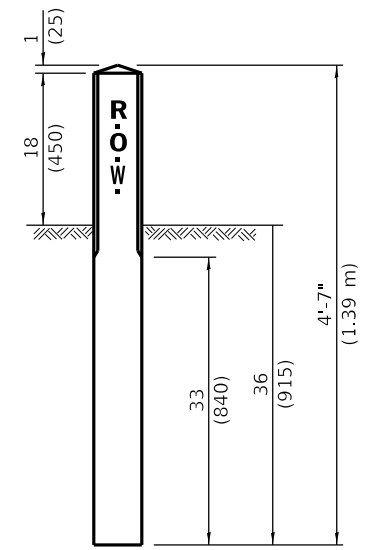

METHOD A

* 2 (50) When shadow box is used.

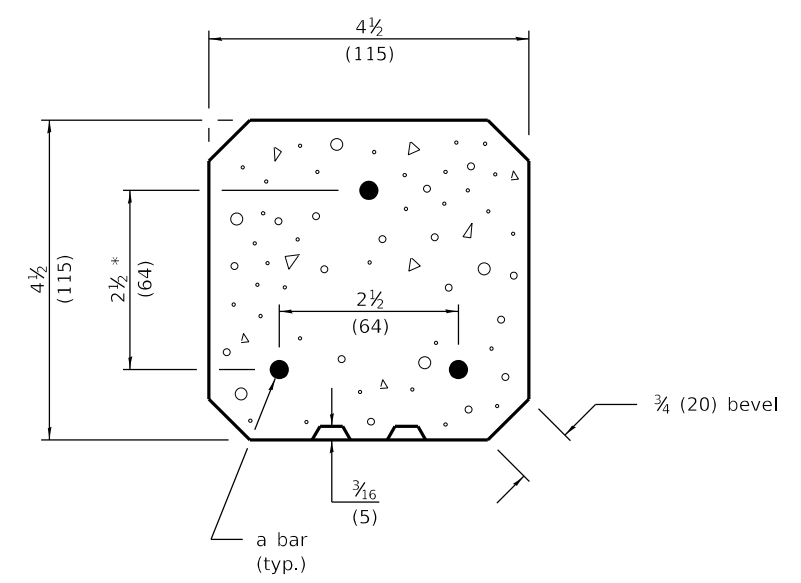

SECTION A-A

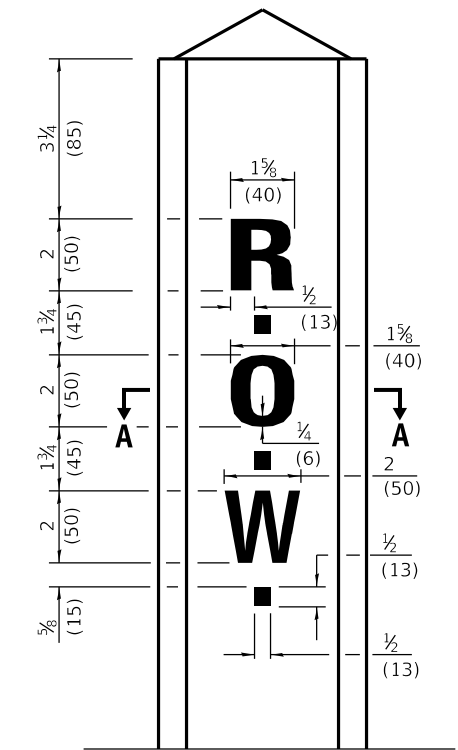

GENERAL NOTE

Reinforcement bars shall be No. 3 (No. 10) unless otherwise specified.

A 2 3/4 x 12 1/2 (70 x 310) shadow box with beveled edges, and a 3/16 (5) thick indentation may be used with the standard lettering shown.

All dimensions are in inches (millimeters) unless otherwise shown.

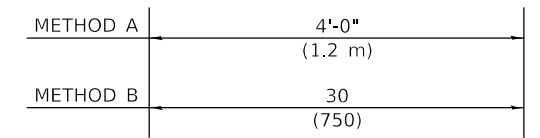

a BAR

Illinois Department of Transportation

PASSED January 1, 2009

ENGINEER OF POLICY AND PROCEDURES

APPROVED January 1, 2009

ENGINEER OF DESIGN AND ENVIRONMENT

ISSUED 1-1-09

DATE	REVISIONS
1-1-09	Switched units to English (metric).
1-1-97	Renum. Standard 1744-6.

RIGHT OF WAY MARKERS

STANDARD 666001-01

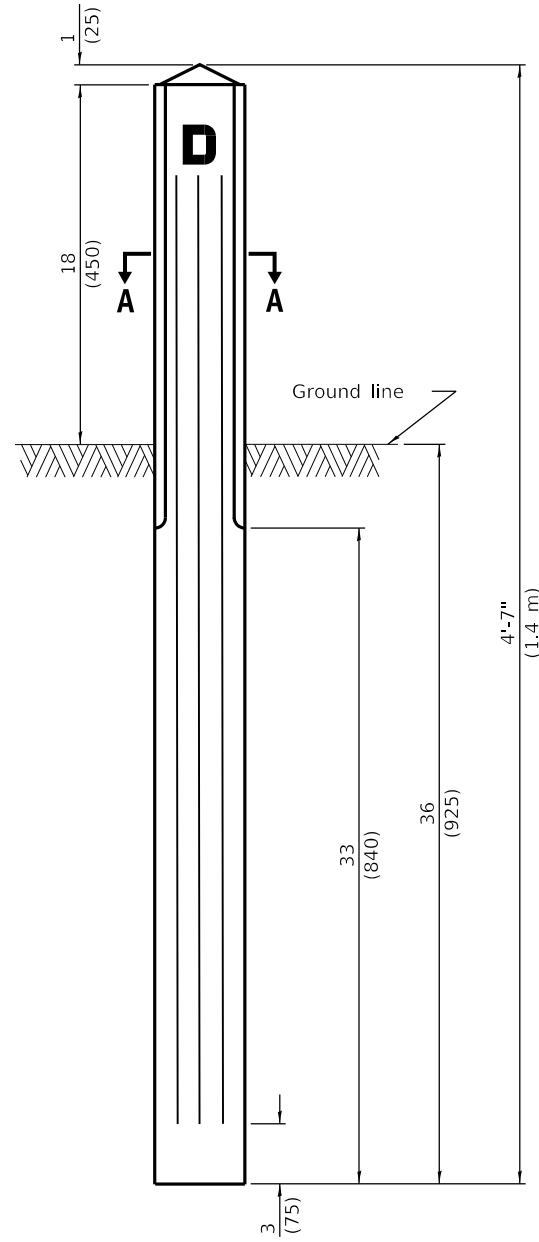

FRONT ELEVATION

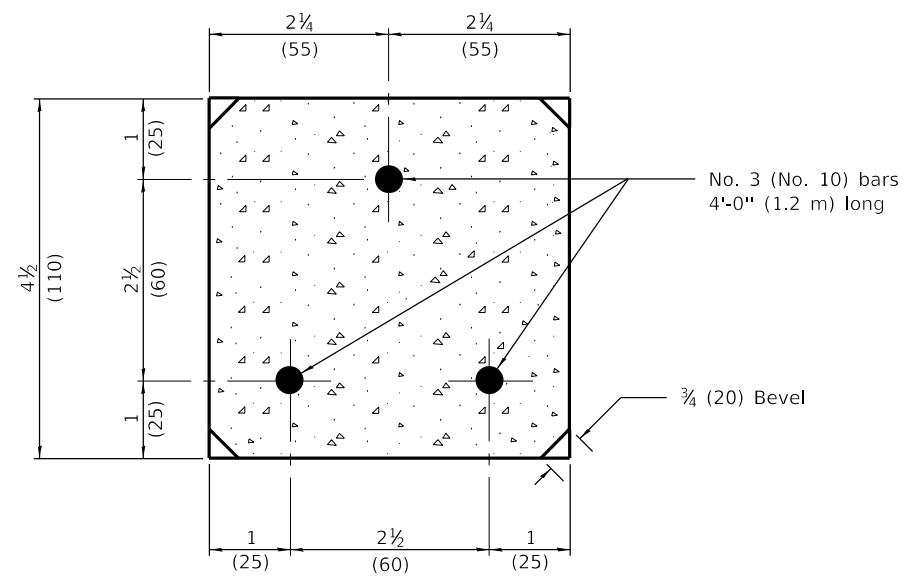

SECTION A-A

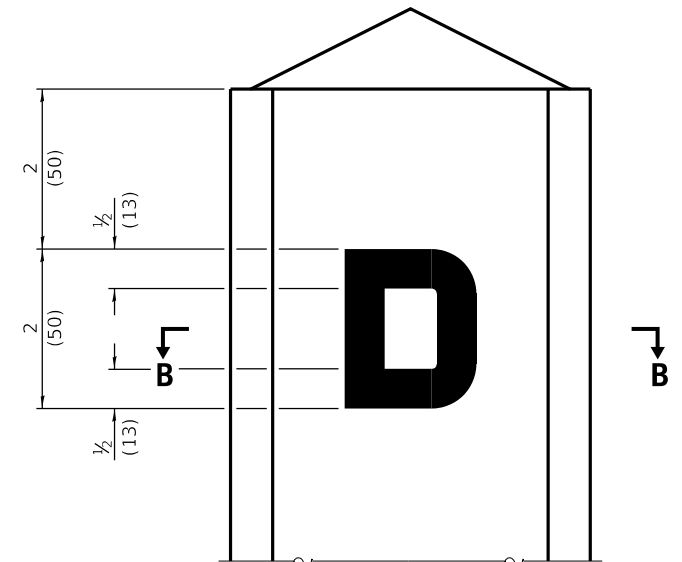

DETAIL OF LETTER

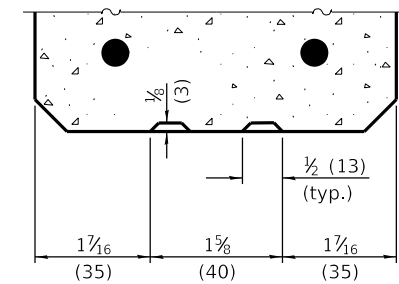

SECTION B-B

All dimensions are in inches (millimeters) unless otherwise shown.

Illinois Department of Transportation

PASSED January 1, 2009

ENGINEER OF POLICY AND PROCEDURES

APPROVED January 1, 2009

ENGINEER OF DESIGN AND ENVIRONMENT

ISSUED 1-1-09

DATE	REVISIONS
1-1-09	Switched units to English (metric).
1-1-97	Renum. Standard 1999-4.

DRAINAGE MARKERS

STANDARD 667001-01

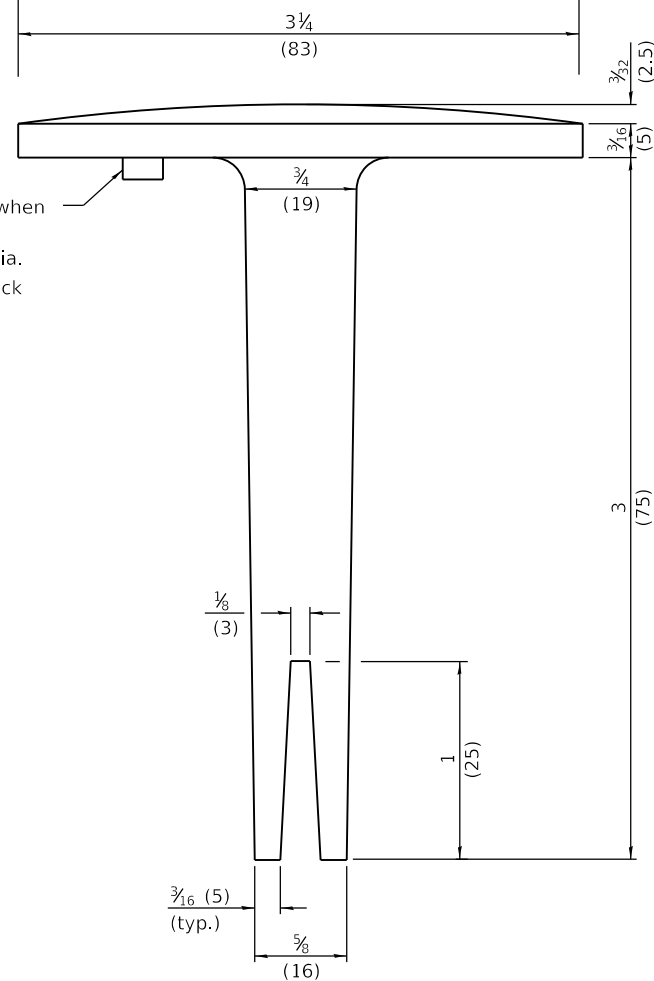
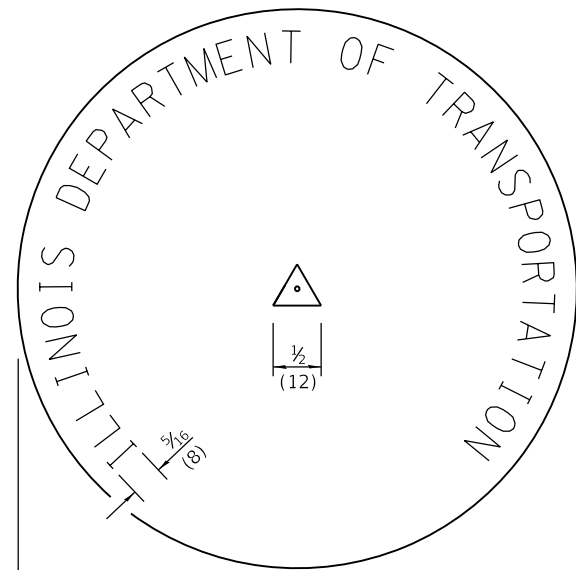

ALUMINUM TABLET

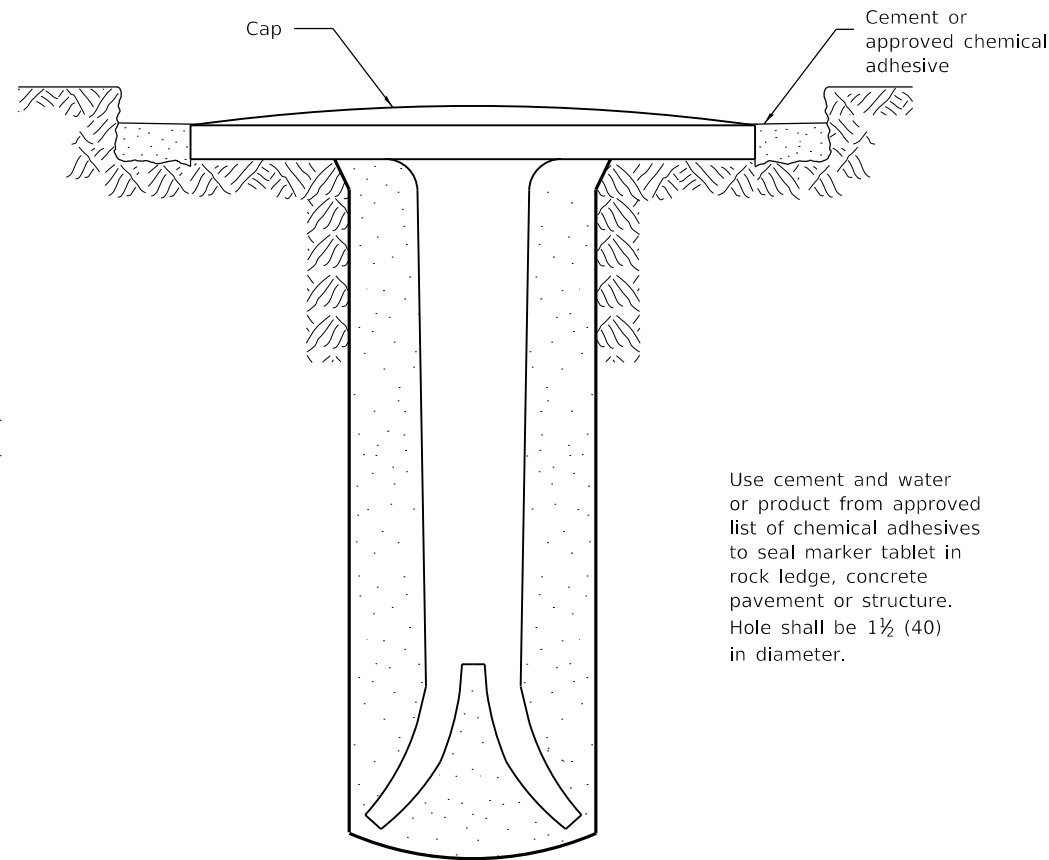

Use cement and water or product from approved list of chemical adhesives to seal marker tablet in rock ledge, concrete pavement or structure. Hole shall be 1 1/2 (40) in diameter.

Tablet constructed in rock ledge or concrete.

TYPE I

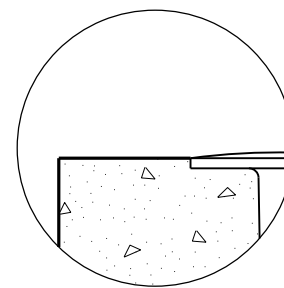

DETAIL A

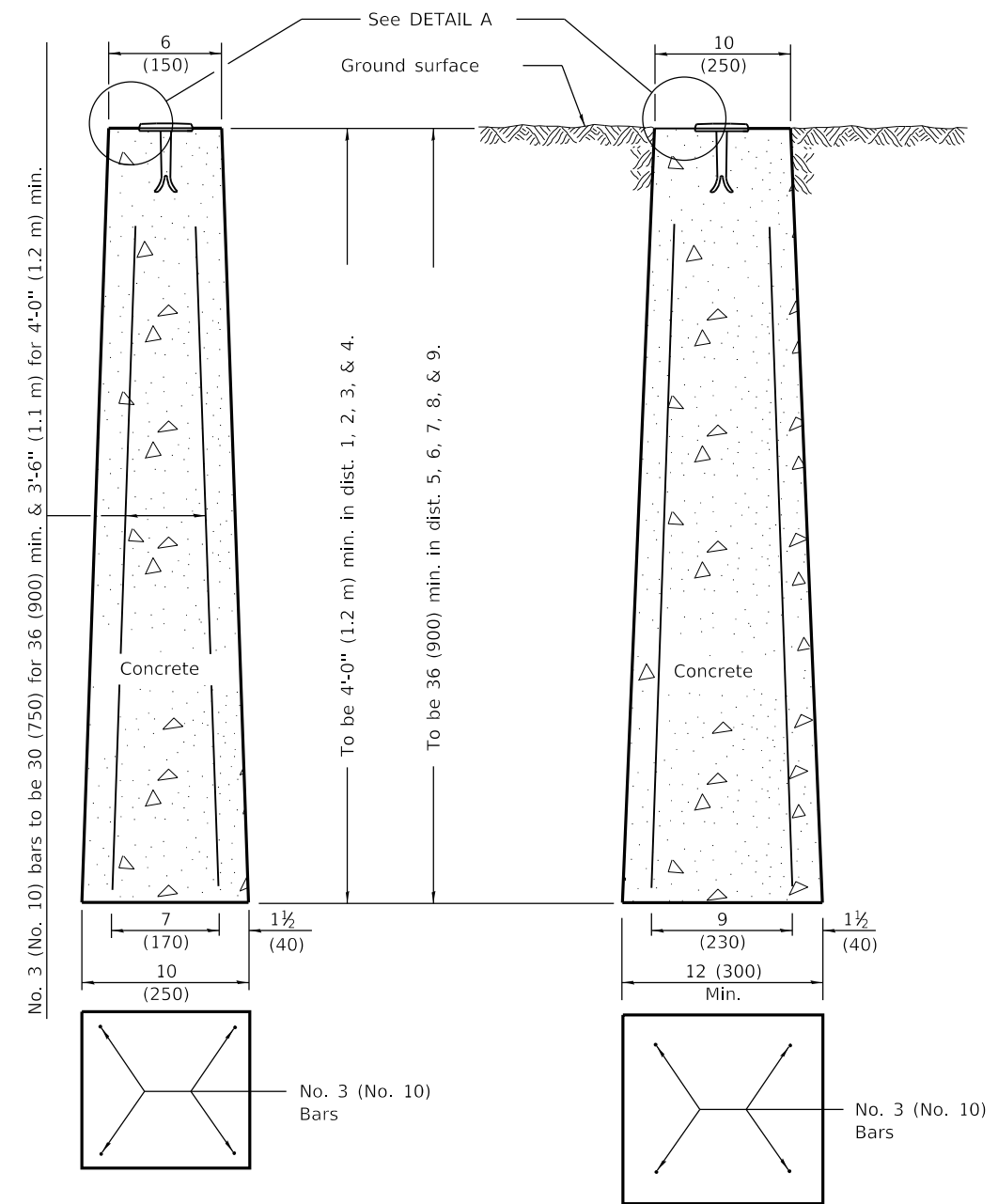

PRECAST MARKER

CAST-IN-PLACE MARKER

TYPE II

All dimensions are in inches (millimeters) unless otherwise shown.

Illinois Department of Transportation

PASSED January 1, 2012
Michael Beard
 ENGINEER OF POLICY AND PROCEDURES

APPROVED January 1, 2012
Scott Schick
 ENGINEER OF DESIGN AND ENVIRONMENT

ISSUED 1-1-97

DATE	REVISIONS
1-1-12	Changed 'epoxy' references to 'chemical adhesives'.
1-1-09	Switched units to English (metric).

PERMANENT SURVEY MARKERS

STANDARD 667101-02

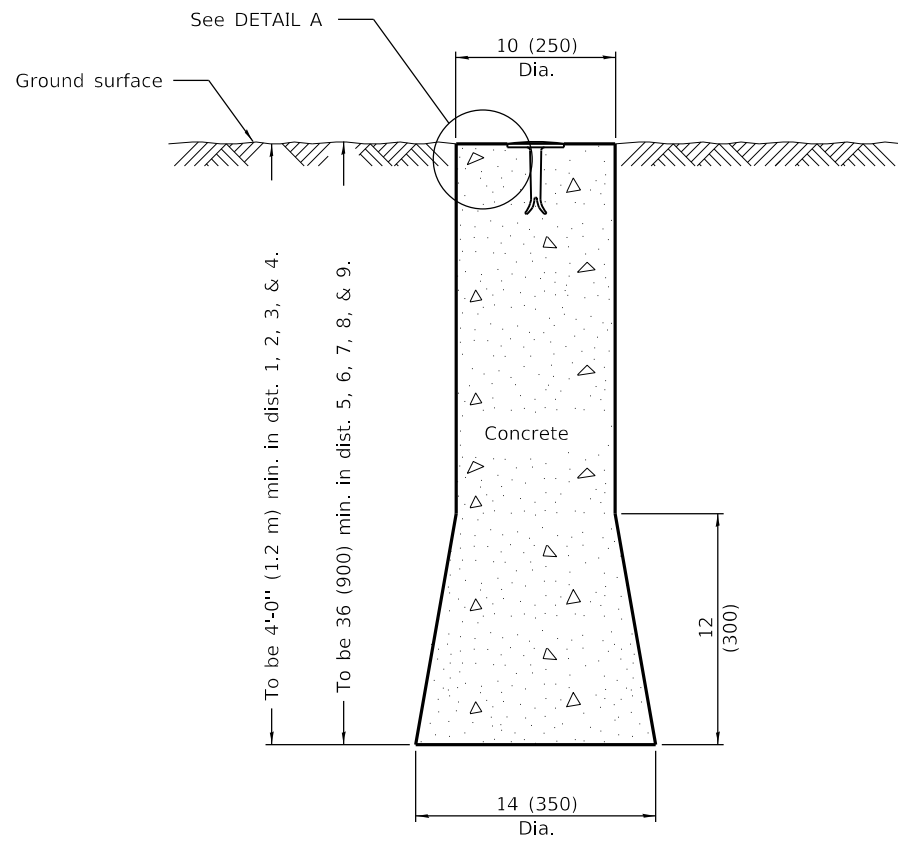

ELEVATION

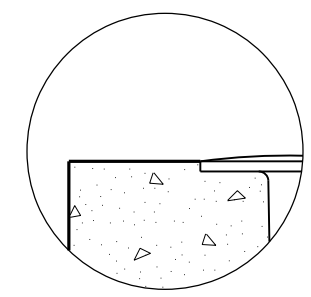

DETAIL A

All dimensions are in inches (millimeters) unless otherwise shown.

DATE	REVISIONS
1-1-09	Switched units to English (metric).
1-1-97	Renum. Standard 2448.
	Revised depth.

U.S. GEOLOGICAL SURVEY AND NATIONAL GEODETIC SURVEY BENCHMARKS RESETTING METHOD

STANDARD 668001-01

Illinois Department of Transportation
 PASSED January 1, 2009

 ENGINEER OF POLICY AND PROCEDURES
 APPROVED January 1, 2009

 ENGINEER OF DESIGN AND ENVIRONMENT

ISSUED 1-1-97



TYPICAL APPLICATIONS

- Landscaping work
- Utility work
- Fencing contracts and maintenance
- Cleaning culverts

GENERAL NOTES

This Standard is used where at all times all vehicles, equipment, workers or their activities are more than 15' (4.5 m) from the edge of pavement.

When the work operation requires that two or more work vehicles cross the 15' (4.5 m) clear zone in any one hour, traffic control shall be according to Standard 701006.

All dimensions are in inches (millimeters) unless otherwise shown.

DATE	REVISIONS
1-1-09	Switched units to English (metric).
1-1-05	Revised title and notes.

**OFF-RD OPERATIONS,
2L, 2W, MORE THAN
15' (4.5 m) AWAY**

STANDARD 701001-02

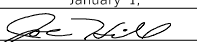
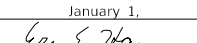
 Illinois Department of Transportation
 PASSED January 1, 2009

 ENGINEER OF OPERATIONS
 APPROVED January 1, 2009

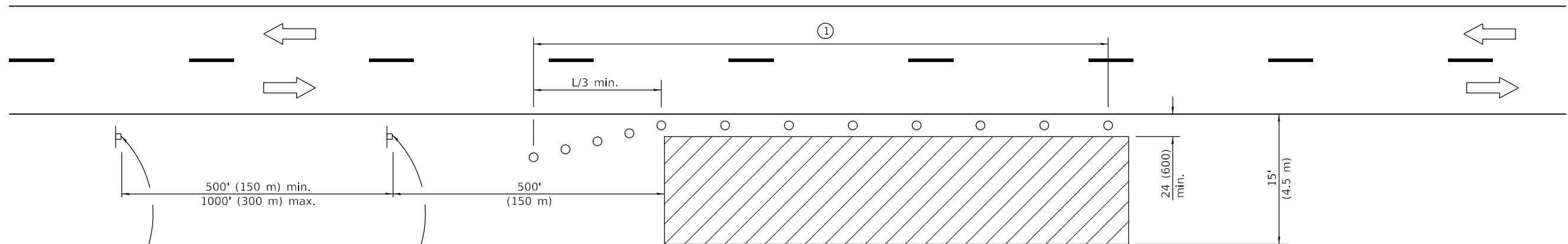
 ENGINEER OF DESIGN AND ENVIRONMENT

ISSUED 1-1-97



For contract construction projects

ROAD CONSTRUCTION AHEAD

W20-1103(0)-48

WORKERS AHEAD

W21-1(0)-48

For maintenance and utility projects



ROAD WORK AHEAD

W20-1(0)-48

TYPICAL APPLICATIONS

- Utility operations
- Culvert extensions
- Side slope changes
- Guardrail installation and maintenance
- Delineator installation
- Landscaping operations
- Shoulder repair
- Sign installation and maintenance

SYMBOLS

-  Work area
-  Sign
-  Cone, drum or barricade

① When the work operation exceeds one hour, cones, drums or barricades shall be placed at 25' (8 m) centers for L/3 distance, and at 50' (15 m) centers through the remainder of the work area.

GENERAL NOTES

This Standard is used where any vehicles, equipment, workers or their activities will encroach in the area 15' (4.5 m) to 24' (600) from the edge of pavement.

Calculate L as follows:

SPEED LIMIT	FORMULAS	
	English	(Metric)
40 mph (70 km/h) or less:	$L = \frac{WS^2}{60}$	$L = \frac{WS^2}{150}$
45 mph (80 km/h) or greater:	$L = (W)(S)$	$L = 0.65(W)(S)$

W = Width of offset in feet (meters).

S = Normal posted speed mph (km/h).

All dimensions are in inches (millimeters) unless otherwise shown.

DATE	REVISIONS
1-1-14	Revised workers sign number to agree with current MUTCD.
1-1-13	Omitted text 'WORKERS' sign.

OFF-RD OPERATIONS, 2L, 2W, 15' (4.5 m) TO 24" (600 mm) FROM PAVEMENT EDGE

STANDARD 701006-05

Illinois Department of Transportation

PASSED January 1, 2014

ENGINEER OF SAFETY ENGINEERING

APPROVED January 1, 2014

ENGINEER OF DESIGN AND ENVIRONMENT

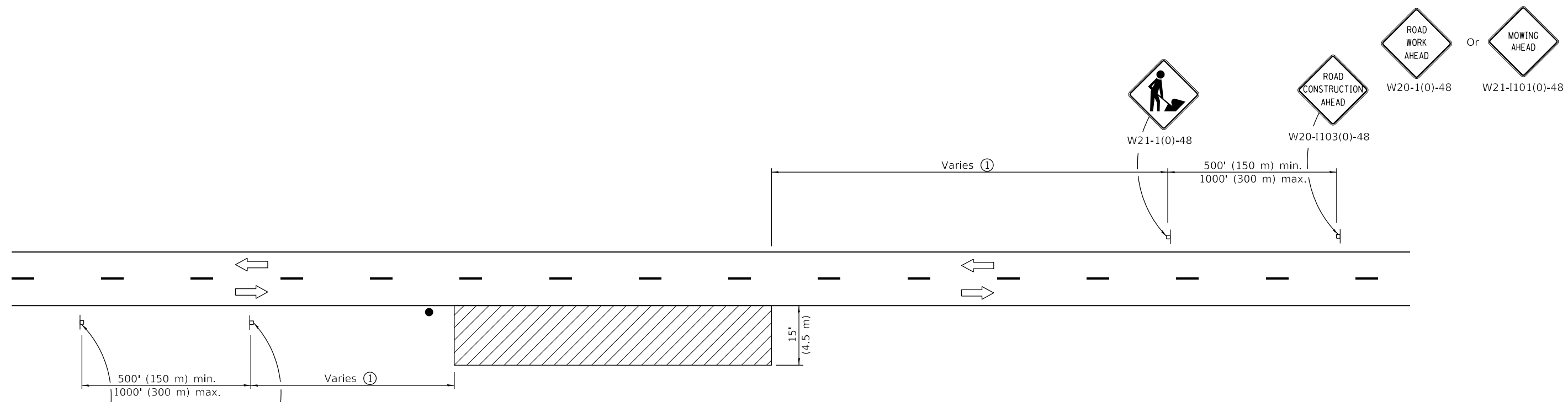

ISSUED 1-1-97

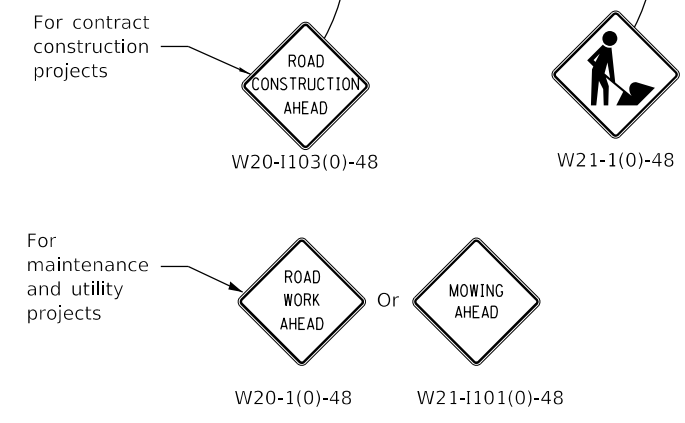

TYPICAL APPLICATIONS
Shoulder work
Utility operations

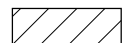

SYMBOLS

-  Work area
-  Sign
-  Flagger with traffic control sign when required

① Minimum distance is 200' (60 m). Maximum distance to be determined by the Engineer but should not exceed 1/2 the length required for one normal working day's operation, or 4 miles (6.4 km) whichever is less.

GENERAL NOTES

This Standard is used where at any time, any vehicle, equipment, workers or their activities require an intermittent or continuous moving operation on the shoulder, where the average speed is 1 mph (2 km/h) or less.

When the work operation does not exceed 60 minutes, traffic control may be according to Standard 701301.

All dimensions are in inches (millimeters) unless otherwise shown.

DATE	REVISIONS
1-1-14	Revised workers sign number to agree with current MUTCD.
1-1-13	Omitted text 'WORKERS' sign.

**OFF-RD MOVING OPERATIONS,
2L, 2W, DAY ONLY**

STANDARD 701011-04

Illinois Department of Transportation

PASSED January 1, 2014
[Signature]
ENGINEER OF SAFETY ENGINEERING

APPROVED January 1, 2014
[Signature]
ENGINEER OF DESIGN AND ENVIRONMENT

ISSUED 1-1-97

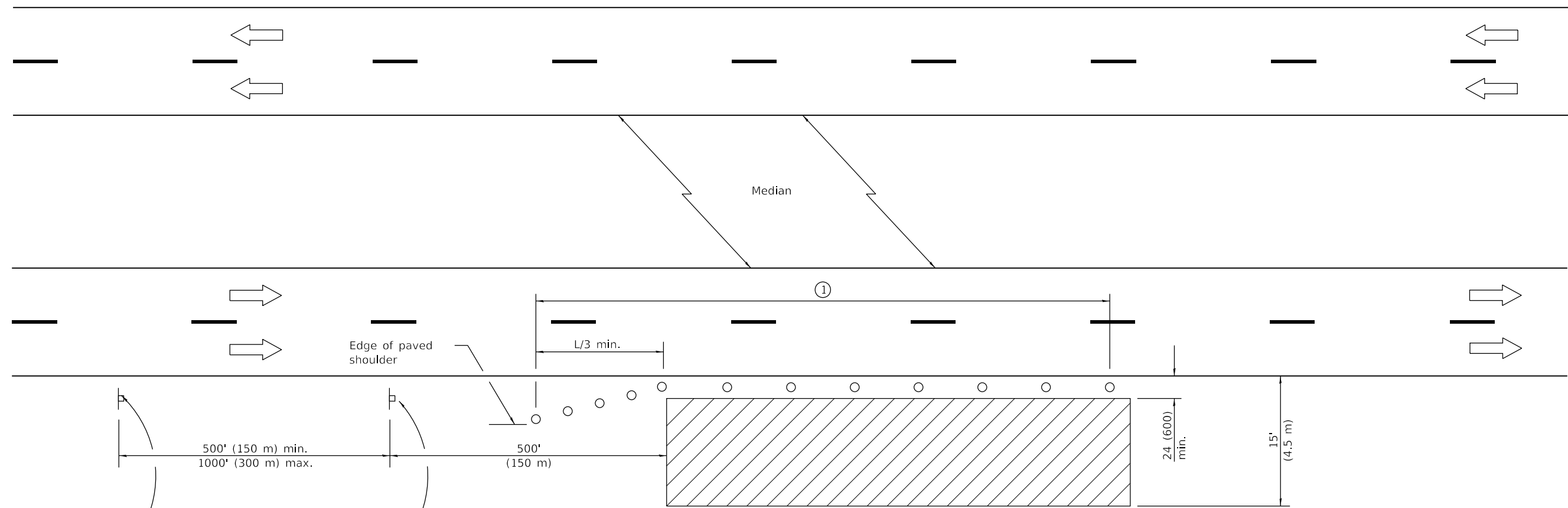

For contract construction projects



W20-1103(0)-48



W21-1(0)-48

For maintenance and utility projects



W20-1(0)-48

TYPICAL APPLICATIONS

- Utility operations
- Culvert extensions
- Side slope changes
- Guardrail installation and maintenance
- Delineator installation
- Landscaping operations
- Shoulder repair
- Sign installation and maintenance

① When the work operation exceeds one hour, cones, drums or barricades shall be placed at 25' (8 m) centers for L/3 distance, and at 50' (15 m) centers through the remainder of the work area.

SYMBOLS

- Work area
- Sign
- Cone, drum or barricade

GENERAL NOTES

This Standard is used where any vehicles, equipment, workers or their activities will encroach in the area 15' (4.5 m) to 24' (600) from the edge of pavement.

Calculate L as follows:

SPEED LIMIT	FORMULAS	
	English	(Metric)
40 mph (70 km/h) or less:	$L = \frac{WS^2}{60}$	$L = \frac{WS^2}{150}$
45 mph (80 km/h) or greater:	$L = (W)(S)$	$L = 0.65(W)(S)$

W = Width of offset in feet (meters).

S = Normal posted speed mph (km/h).

All dimensions are in inches (millimeters) unless otherwise shown.

DATE	REVISIONS
4-1-16	Corrected typo in title.
1-1-14	Revised workers sign number to agree with current MUTCD.

OFF-RD OPERATIONS, MULTILANE, 15' (4.5 m) TO 24" (600 mm) FROM PAVEMENT EDGE

STANDARD 701101-05

Illinois Department of Transportation

PASSED April 1, 2016

 ENGINEER OF SAFETY ENGINEERING

APPROVED April 1, 2016

 ENGINEER OF DESIGN AND ENVIRONMENT

ISSUED 1-1-97

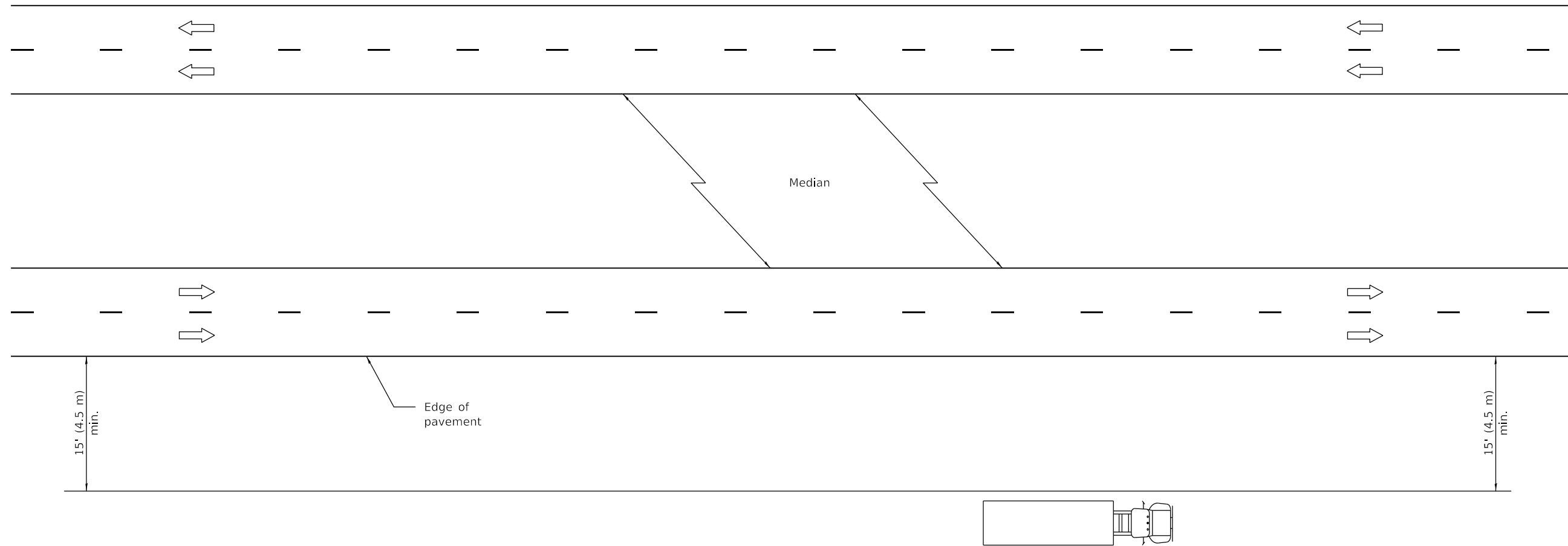

TYPICAL APPLICATIONS

- Landscaping work
- Utility work
- Fencing contracts

GENERAL NOTES

This Standard is used where at all times all vehicles, equipment, workers or their activities are more than 15' (4.5 m) from the edge of pavement.

When the work operation requires that two or more work vehicles cross the 15' (4.5 m) clear zone in any one hour, traffic control shall be according to Standard 701101.

This Standard also applies to work performed in the median more than 15' (4.5 m) from either pavement.

All dimensions are in inches (millimeters) unless otherwise shown.

DATE	REVISIONS
1-1-05	Switched units to English (metric).
1-1-05	Revised title.

**OFF-RD OPERATIONS, MULTILANE,
MORE THAN 15' (4.5 m) AWAY**

STANDARD 701106-02

Illinois Department of Transportation

PASSED January 1, 2009

ENGINEER OF OPERATIONS

APPROVED January 1, 2009

ENGINEER OF DESIGN AND ENVIRONMENT

ISSUED 1-1-97

- ① Devices at 20' (6 m) centers in the taper.
- ② Cones at 25' (8 m) centers for the first 150' (45 m). Additional cones may be placed at 50' (15 m) centers. When drums or barricades are used, these intervals between devices may be doubled.

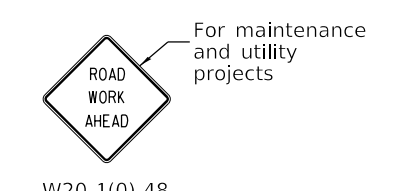
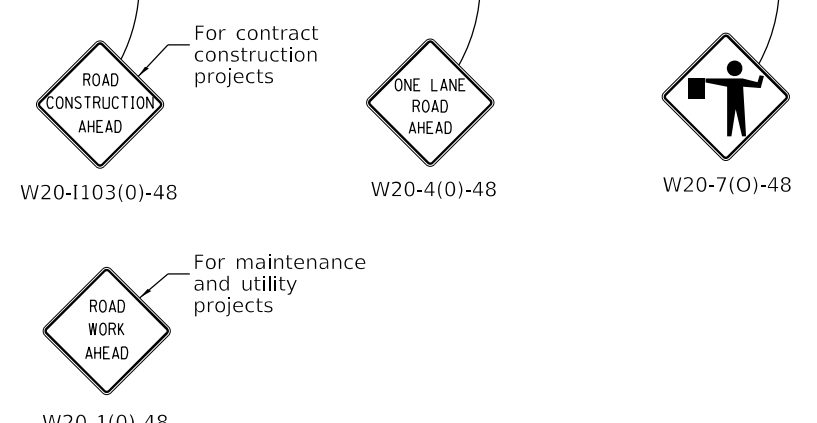
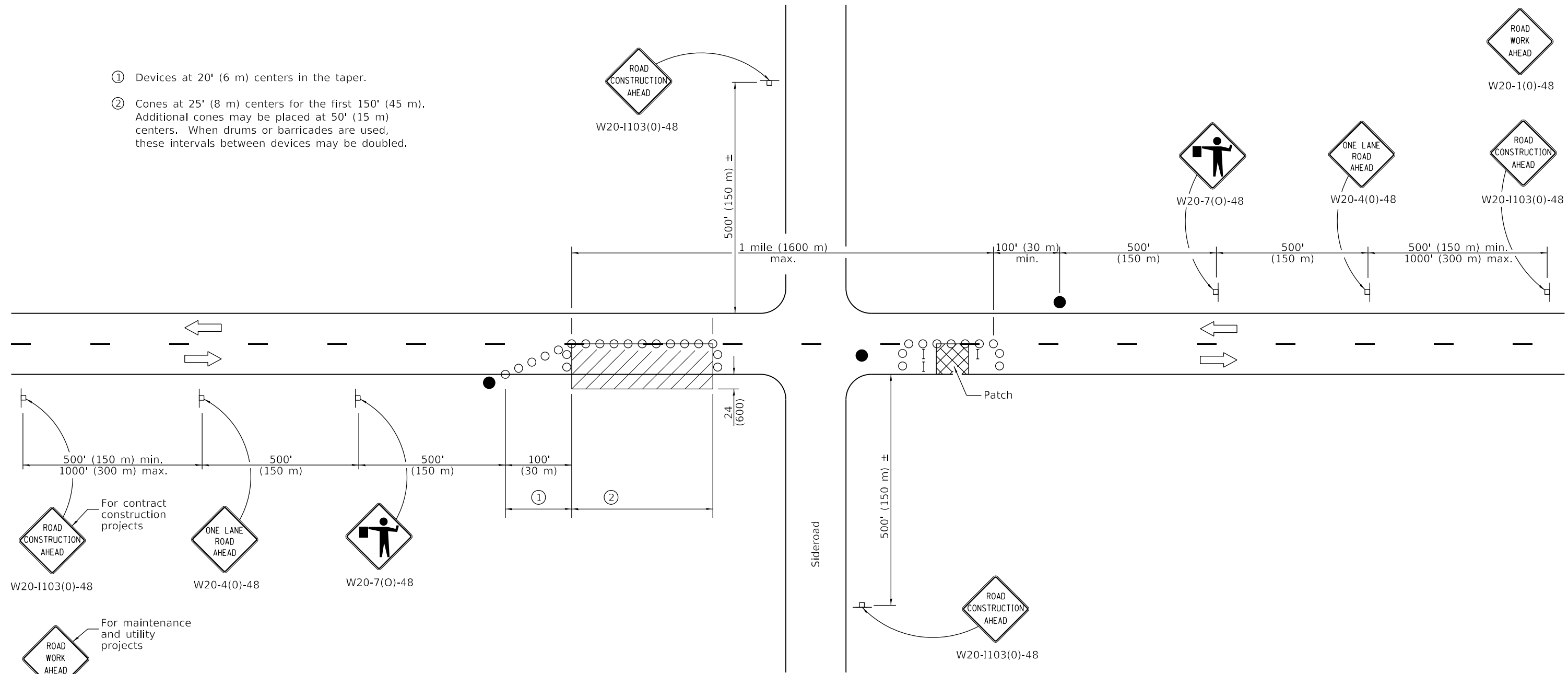

TYPICAL APPLICATIONS

- Isolated patching
- Utility operations
- Storm sewer
- Culverts
- Cable placement

SYMBOLS

- Work area
- Sign
- Barricade or drum
- Cone, drum or barricade
- Flagger with traffic control sign

GENERAL NOTES

This Standard is used where at any time, any vehicles, equipment, workers or their activities will encroach in the area between the center line and a line 24 (600) outside the edge of pavement for daylight operation.

When the distance between successive work areas exceeds 2000' (600 m), additional warning signs, flaggers, and taper shall be placed as shown.

All dimensions are in inches (millimeters) unless otherwise shown.

Illinois Department of Transportation

APPROVED January 1, 2019

 ENGINEER OF SAFETY PROG. AND ENGINEERING

APPROVED January 1, 2019

 ENGINEER OF DESIGN AND ENVIRONMENT

ISSUED 1-1-97

DATE	REVISIONS
1-1-19	Revised device spacing in taper.
1-1-11	Revised flagger sign.

**LANE CLOSURE, 2L, 2W,
DAY ONLY,
FOR SPEEDS ≥ 45 MPH**

STANDARD 701201-05

- ① Barricades or drums at 20' (6 m) centers in the taper.
- ② Cones at 25' (8 m) centers for the first 150' (45 m). Additional cones may be placed at 50' (15 m) centers. When barricades or drums are used, these intervals between devices may be doubled.

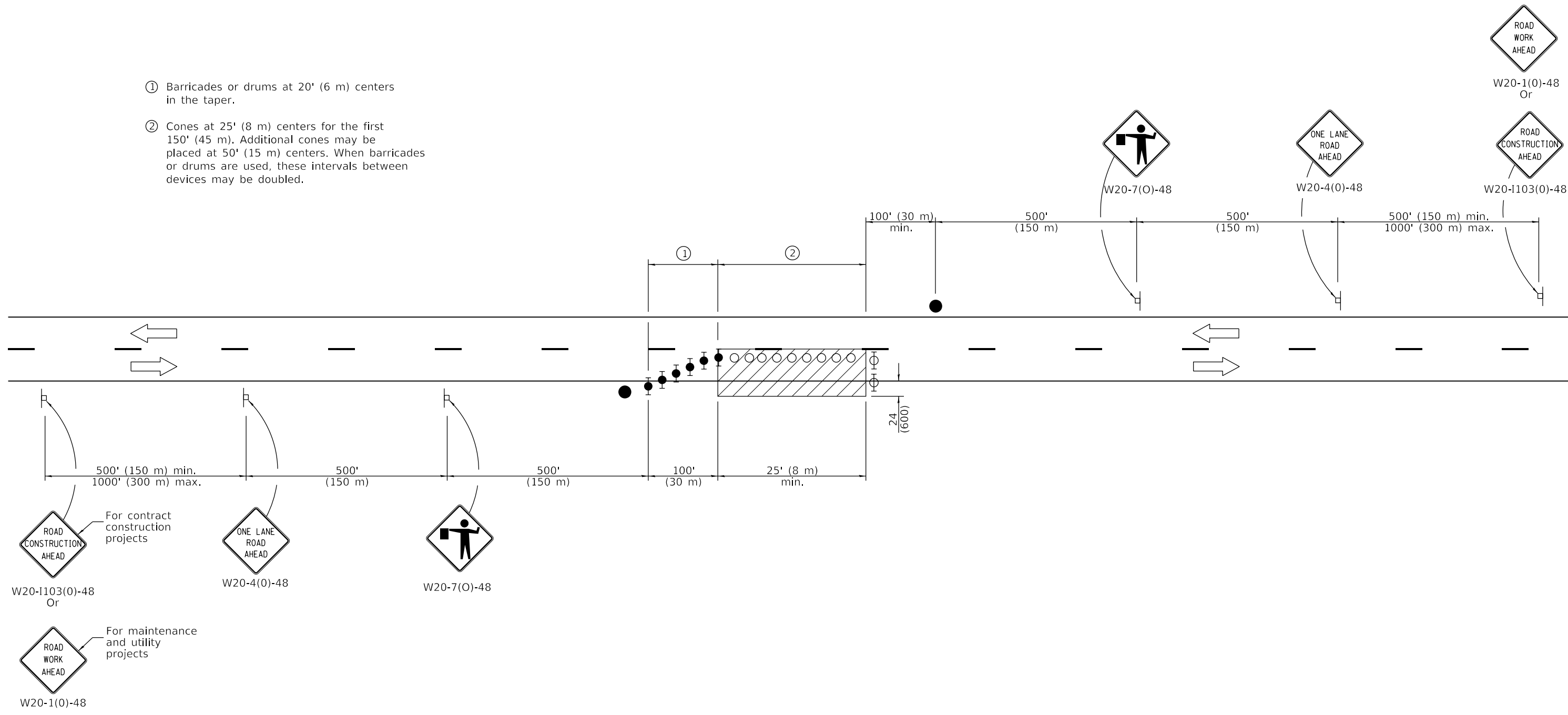

For contract construction projects
 ROAD CONSTRUCTION AHEAD
 W20-1103(0)-48
 Or

ONE LANE ROAD AHEAD
 W20-4(0)-48

ROAD WORK AHEAD
 W20-7(0)-48

For maintenance and utility projects
 ROAD WORK AHEAD
 W20-1(0)-48

TYPICAL APPLICATIONS

Isolated patch
 Installation of drainage structure
 Utility operations

SYMBOLS

- Work area
- Sign
- Flagger with traffic control sign
- Cone, drum or barricade
- Barricade or drum with flashing light
- Barricade or drum with steady burning light

GENERAL NOTES

This Standard is used where at any time, any vehicle, equipment, workers or their activities will encroach in the area between the center line and a line 24 (600) from the edge of pavement for nighttime operation.

All dimensions are in inches (millimeters) unless otherwise shown.

DATE	REVISIONS
1-1-19	Revised device spacing in taper and added cones as an option.
1-1-18	Omitted steady burning lights in tangent.

**LANE CLOSURE, 2L, 2W,
 NIGHT ONLY,
 FOR SPEEDS ≥ 45 MPH**

STANDARD 701206-05

Illinois Department of Transportation

APPROVED January 1, 2019

 ENGINEER OF SAFETY PROG. AND ENGINEERING

APPROVED January 1, 2019

 ENGINEER OF DESIGN AND ENVIRONMENT

ISSUED 1-1-97

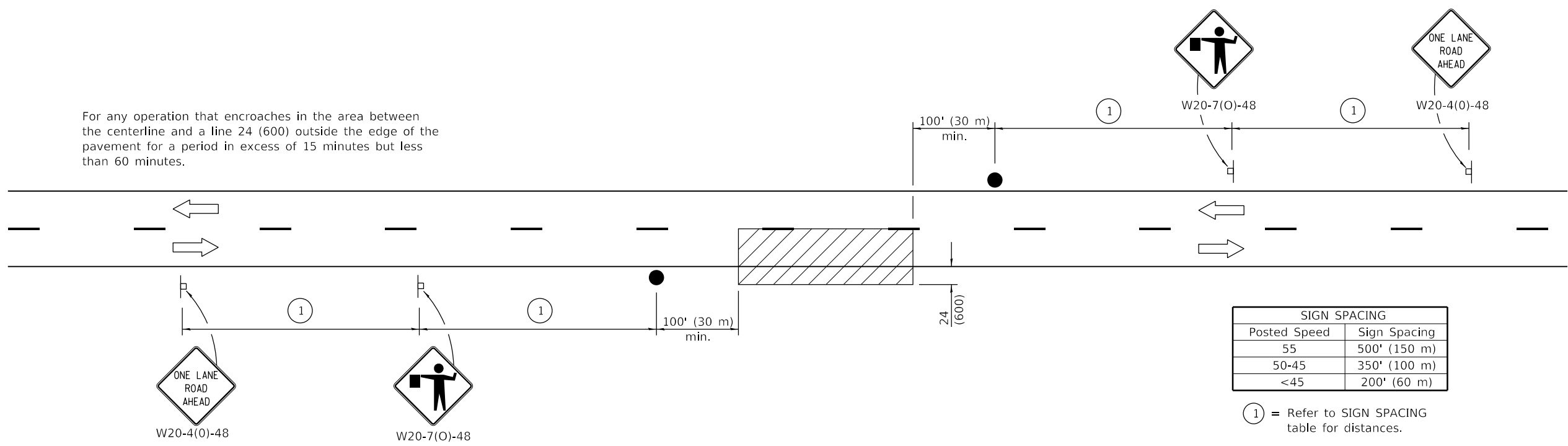
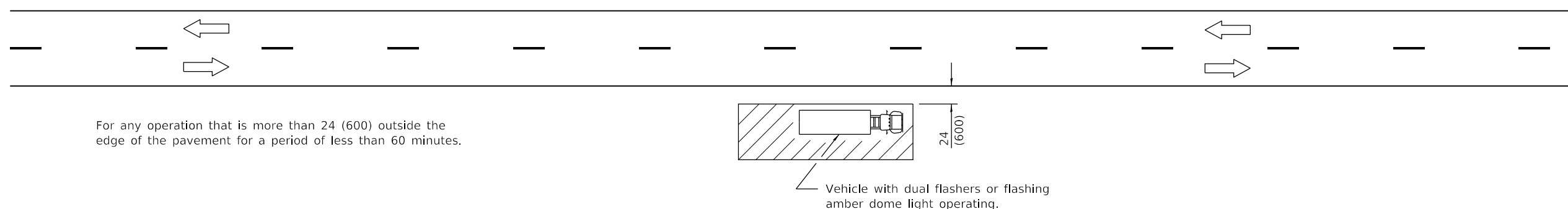
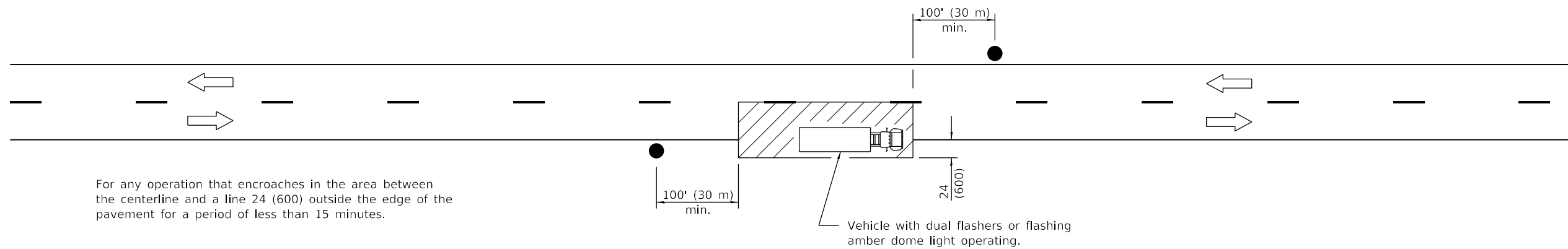

TYPICAL APPLICATIONS

- Marking patches
- Field survey
- String line
- Utility operations
- Cleaning up debris on pavement

SYMBOLS

- Work area
- Sign on portable or permanent support
- Flagger with traffic control sign

All dimensions are in inches (millimeters) unless otherwise shown.

Illinois Department of Transportation

PASSED January 1, 2011
Amelia Adams
 ENGINEER OF SAFETY ENGINEERING

APPROVED January 1, 2011
Scott Schick
 ENGINEER OF DESIGN AND ENVIRONMENT

ISSUED 1-1-97

DATE	REVISIONS
1-1-11	Revised flagger sign.
1-1-09	Switched units to English (metric).

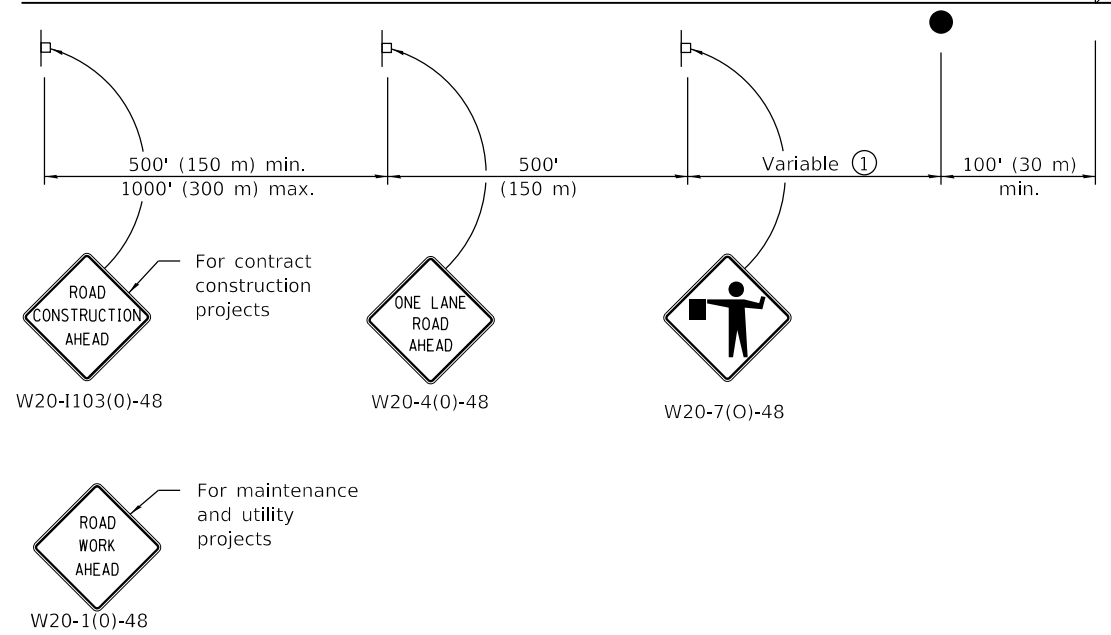
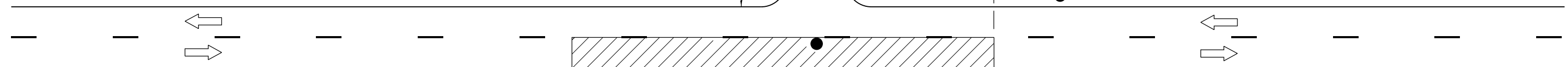
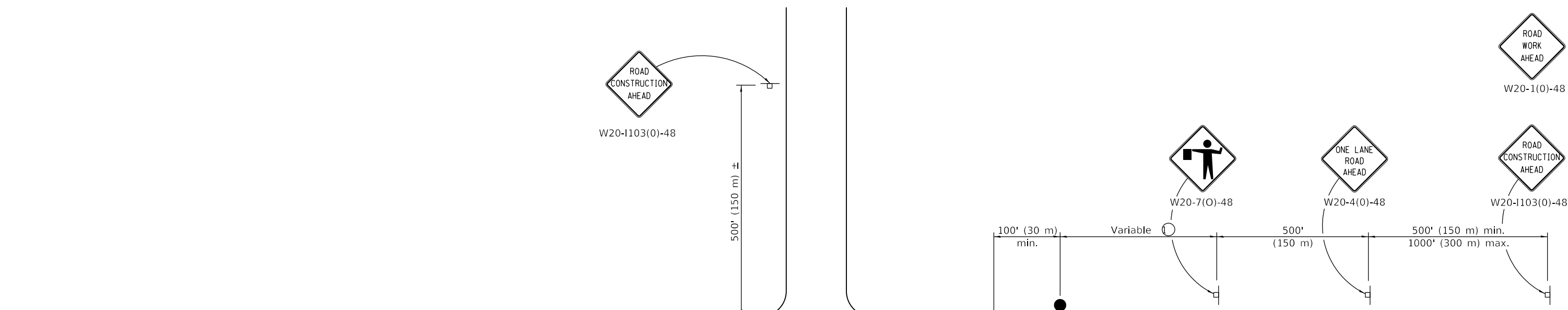

LANE CLOSURE, 2L, 2W, SHORT TIME OPERATIONS

STANDARD 701301-04



TYPICAL APPLICATIONS
 Bituminous resurfacing
 Milling operations
 Utility operations
 Shoulder operations

SYMBOLS

-  Work area
-  Sign on portable or permanent support
-  Flagger with traffic control sign

① Minimum distance is 200' (60 m). Maximum distance to be determined by the Engineer but should not exceed ½ the length required for one normal working day's operation or 2 miles (3200 m), whichever is less.

GENERAL NOTES

This Standard is used where at any time, any vehicle, equipment, workers or their activities require an intermittent or continuous moving operation on the pavement where the average speed of movement is greater than ½ mph (1 km/h) and less than 4 mph (6 km/h).
 When the operation does not exceed 60 minutes, traffic control may be according to Standard 701301.

All dimensions are in inches (millimeters) unless otherwise shown.

DATE	REVISIONS
1-1-18	Revised lower speed limit for operation to ½ mph.
1-1-11	Revised flagger sign.

LANE CLOSURE, 2L, 2W, SLOW MOVING OPERATIONS DAY ONLY, FOR SPEEDS ≥ 45 MPH

STANDARD 701306-04

Illinois Department of Transportation

PASSED January 1, 2018
Paul L. ...
 ENGINEER OF SAFETY PROG. AND ENGINEERING

APPROVED January 1, 2018
Walter M. ...
 ENGINEER OF DESIGN AND ENVIRONMENT

ISSUED 1-1-97

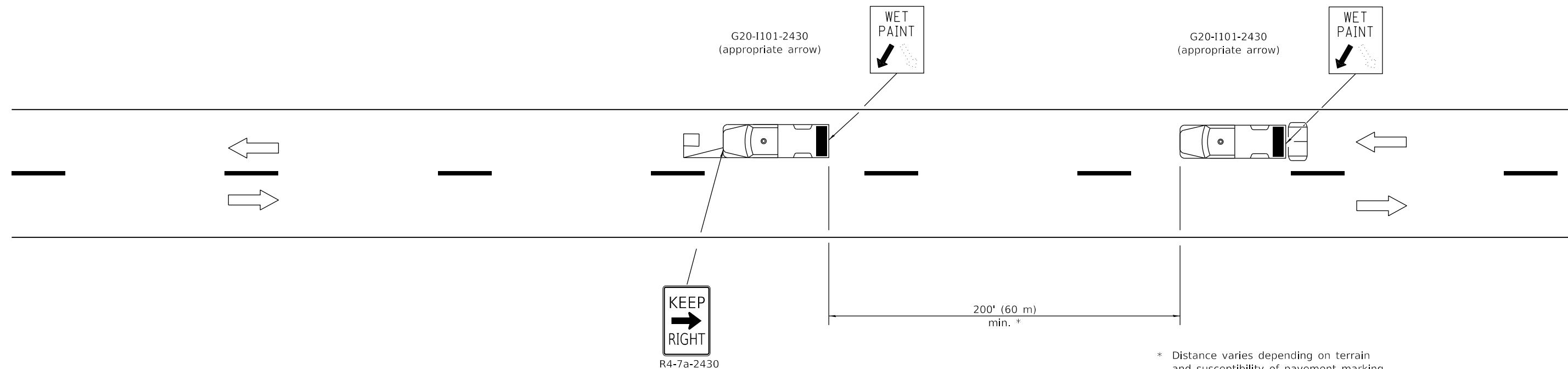



* Distance varies depending on terrain and susceptibility of pavement marking or crack sealant to wheel tracking.

TYPICAL APPLICATIONS

- Landscaping work
- Utility work
- Pavement marking
- Weed spraying
- Roadometer measurements
- Debris cleanup
- Crack pouring

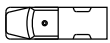
SYMBOLS

-  Arrow board (Hazard Mode only)
-  Truck with headlights, emergency flashers and flashing amber light. (visible from all directions)
-  18x18 (450x450) min. orange flag (use when guide wheel is used)
-  Truck mounted attenuator

GENERAL NOTES

This Standard is used where any vehicle, equipment, workers or their activities will require a continuous moving operation where the average speed is greater than 3 mph (5 km/h).

For shoulder operations not encroaching on the pavement, use DETAIL A, Standard 701426.

All dimensions are in inches (millimeters) unless otherwise shown.

DATE	REVISIONS
1-1-09	Switched units to English (metric). Omitted Pass With Care sign.
1-1-00	Elim. speed restrictions in Standard title.

**LANE CLOSURE 2L, 2W
MOVING OPERATIONS-
DAY ONLY**

STANDARD 701311-03

Illinois Department of Transportation

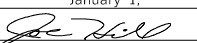
PASSED January 1, 2009

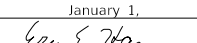
 ENGINEER OF OPERATIONS

APPROVED January 1, 2009

 ENGINEER OF DESIGN AND ENVIRONMENT

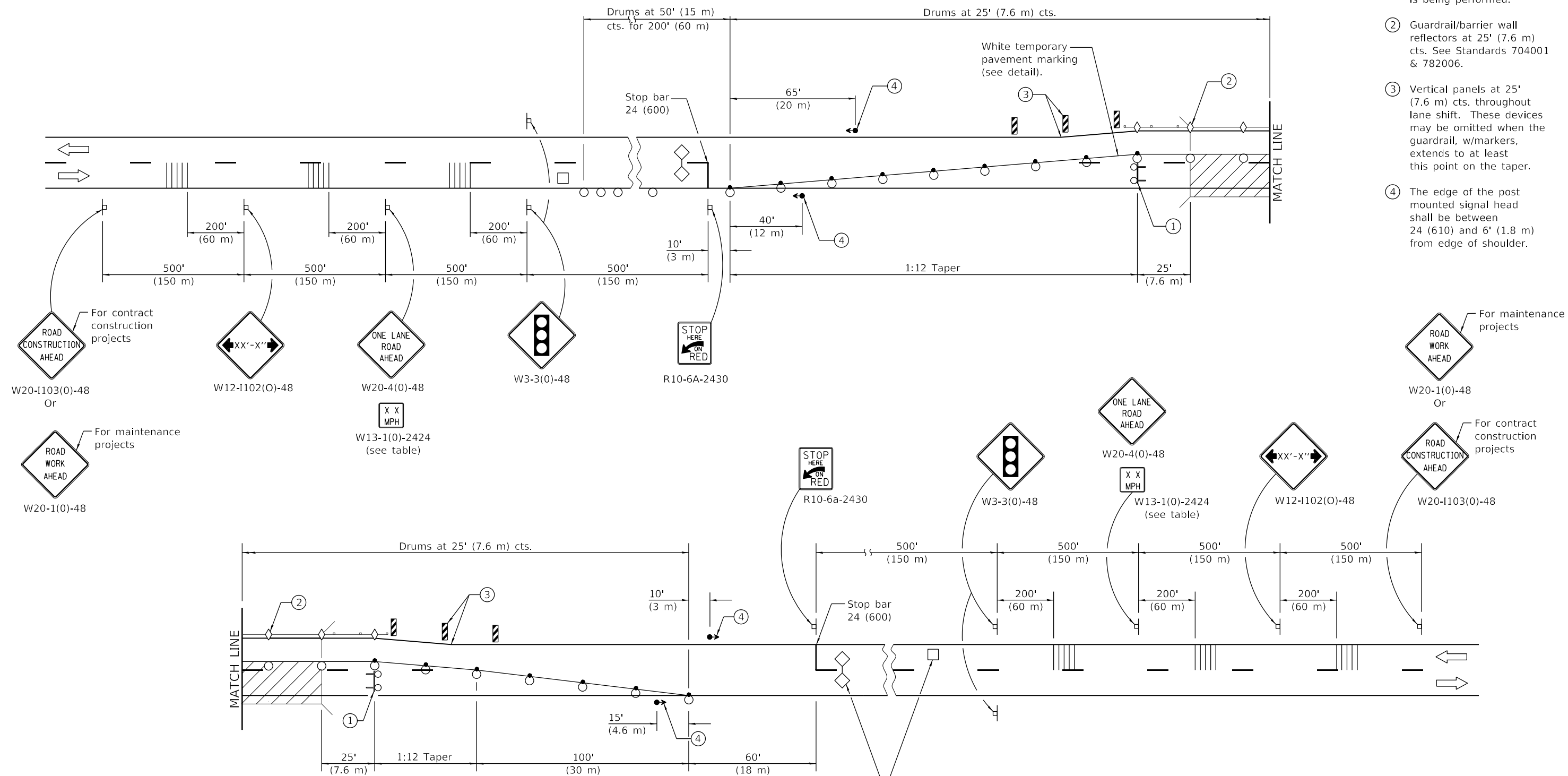
ISSUED 1-1-97

- ① Type III barricade to be placed when no work is being performed.
- ② Guardrail/barrier wall reflectors at 25' (7.6 m) cts. See Standards 704001 & 782006.
- ③ Vertical panels at 25' (7.6 m) cts. throughout lane shift. These devices may be omitted when the guardrail, w/markers, extends to at least this point on the taper.
- ④ The edge of the post mounted signal head shall be between 24 (610) and 6' (1.8 m) from edge of shoulder.



Type III barricade with flashing lights

See detail for placement of detector loops.

SYMBOLS

- Work area
- Sign
- Traffic signal
- Detector loops
- Type III barricade with flashing lights
- Drum with steady burn bi-directional light
- Temporary rumble strip (when specified)
- Crystal, bidirectional guardrail/barrier wall reflector
- Double vertical panel (see detail)
- Drum

See Sheet 2 for GENERAL NOTES.

DATE	REVISIONS
1-1-20	Revised from F-shape to constant slope parapet.
1-1-18	Omitted lights in tangents.
	Changed lights in tapers to steady burn bi-dir.
1-1-17	Revised note ③.

**LANE CLOSURE, 2L, 2W,
BRIDGE REPAIR,
FOR SPEEDS ≥ 45 MPH**

(Sheet 1 of 2)

STANDARD 701316-13

Illinois Department of Transportation

PASSED January 1, 2020

 ENGINEER OF SAFETY PROG. AND ENGINEERING

APPROVED January 1, 2020

 ENGINEER OF DESIGN AND ENVIRONMENT

ISSUED 1-1-97

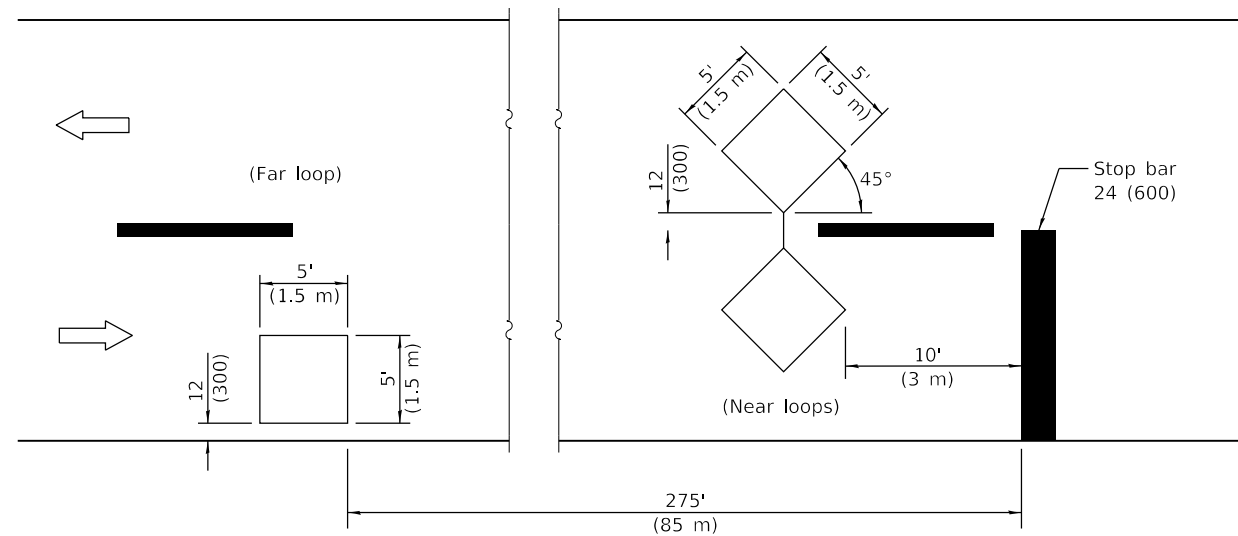

DETECTOR LOOPS

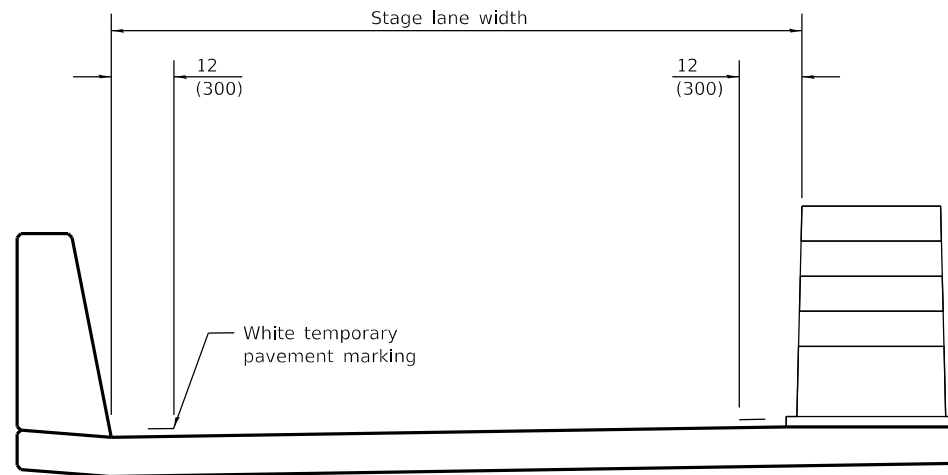

TEMPORARY PAVEMENT MARKING

TRAFFIC SIGNAL SEQUENCE						
PHASE	A			B		
INTERVAL	1	2	3	4	5	6
NORTHBOUND OR EASTBOUND	G	Y	R	R	R	R
SOUTHBOUND OR WESTBOUND	R	R	R	G	Y	R

ADVISORY SPEED LIMIT	
NORMAL POSTED SPEED	ADVISORY SPEED
55 - 45 mph	40 mph
40 mph	35 mph
35 - 30 mph	30 mph

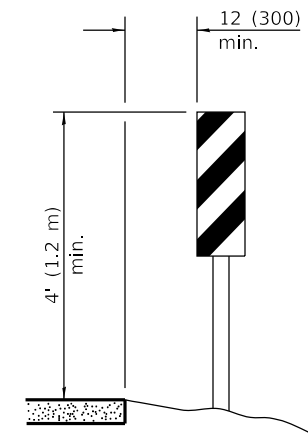

VERTICAL PANELS
(Post mounted, one each side)

GENERAL NOTES

This Standard is used where, at any time any vehicle, equipment, workers or their activities will encroach on one lane of a bridge and traffic signals are required.

When traffic signals are not in operation, flaggers shall be used and traffic control devices shall conform to Standard 701201 or 701206.

Existing or temporary pavement markings shall be on both sides of open lane from stop bar to stop bar.

All dimensions are in inches (millimeters) unless otherwise shown.

**LANE CLOSURE, 2L, 2W,
BRIDGE REPAIR,
FOR SPEEDS ≥ 45 MPH**

(Sheet 2 of 2)

STANDARD 701316-13

Illinois Department of Transportation

PASSED January 1, 2020

 ENGINEER OF SAFETY PROG. AND ENGINEERING

APPROVED January 1, 2020

 ENGINEER OF DESIGN AND ENVIRONMENT

ISSUED 1-1-97

- ① Type III barricade to be placed when no work is being performed.
- ② Guardrail/barrier wall reflectors at 25' (7.6 m) cts. See Standards 704001 & 782006.
- ③ When temp. bridge rail is specified, it shall be connected to the temp. conc. barrier using a traffic barrier terminal Type 11.
- ④ Vertical panels at 25' (7.6 m) cts. throughout lane shift. These devices may be omitted when the guardrail, w/markers, extends to at least this point on the taper.
- ⑤ The edge of the post mounted signal head shall be between 24 (610) and 6' (1.8 m) from edge of shoulder.

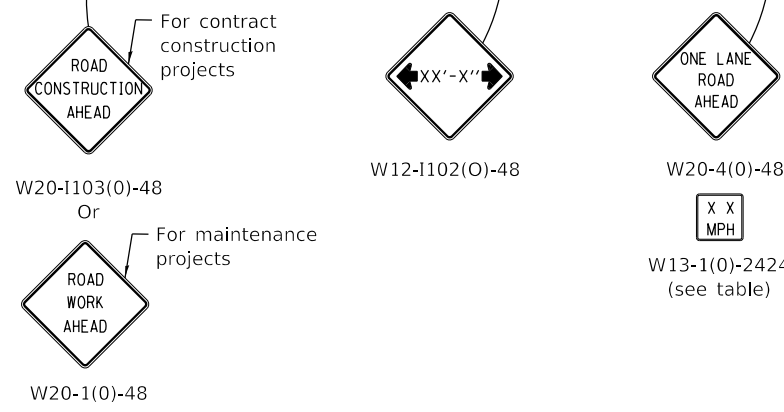
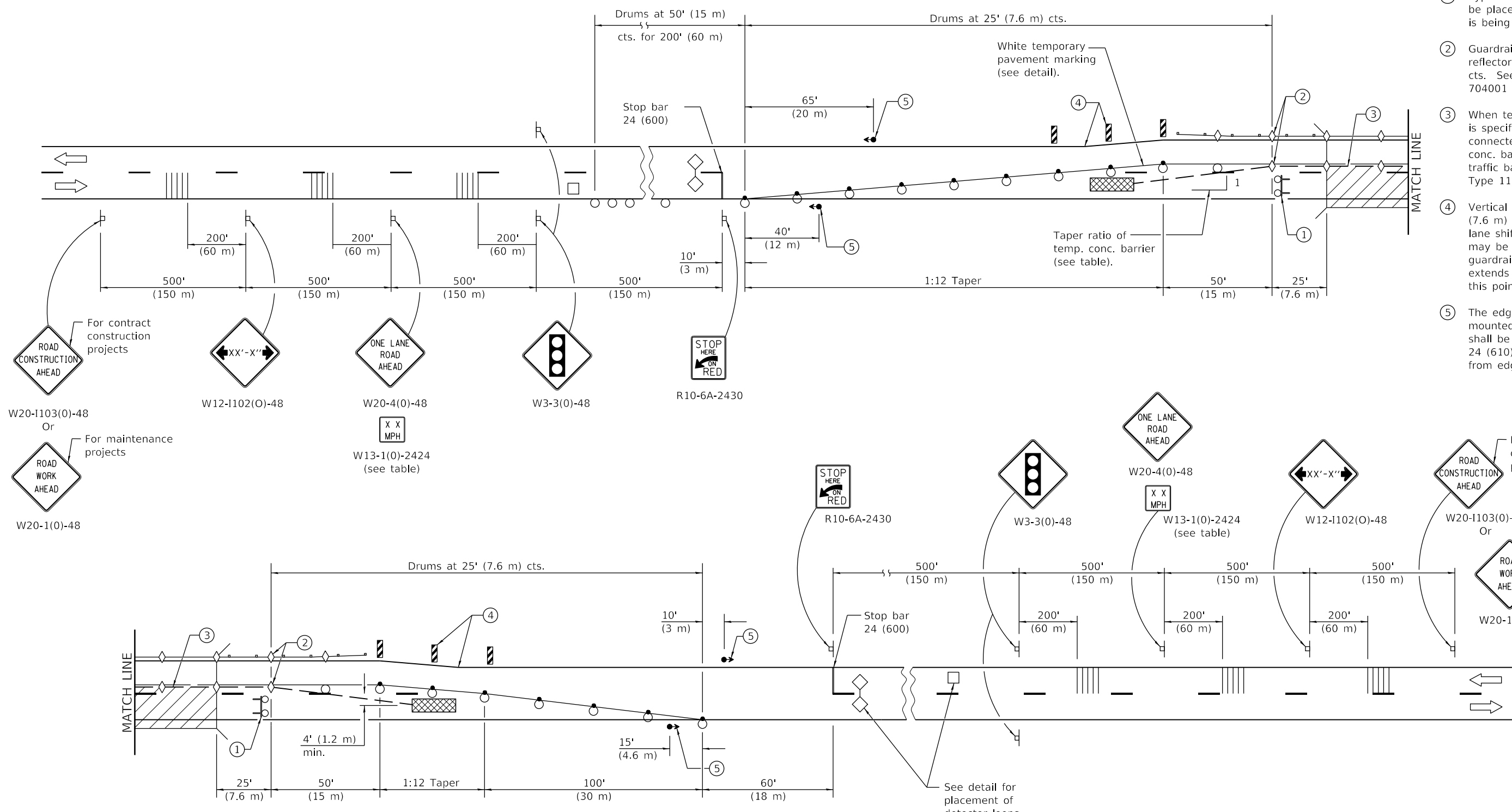

SYMBOLS

- Work area
- Sign
- Type III barricade with flashing lights
- Traffic signal
- Detector loops
- Impact attenuator
- Drum with steady burning bi-directional light
- Temporary concrete barrier
- Temporary rumble strip (when specified)
- Double vertical panel (see detail)
- Crystal, bidirectional guardrail/barrier wall reflector
- Drum

See Sheet 2 for GENERAL NOTES

Illinois Department of Transportation

PASSED January 1, 2020
Cynthia Watt
 ENGINEER OF SAFETY PROG. AND ENGINEERING

APPROVED January 1, 2020
J. Ed. Elk
 ENGINEER OF DESIGN AND ENVIRONMENT

ISSUED 1-1-97

DATE	REVISIONS
1-1-20	Revised from F-shape to constant slope parapet.
1-1-18	Omitted lights in tangents.
1-1-17	Added flashing lights to Type III barricades. Revised note ④.

**LANE CLOSURE, 2L, 2W,
BRIDGE REPAIR WITH BARRIER**

(Sheet 1 of 2)

STANDARD 701321-18

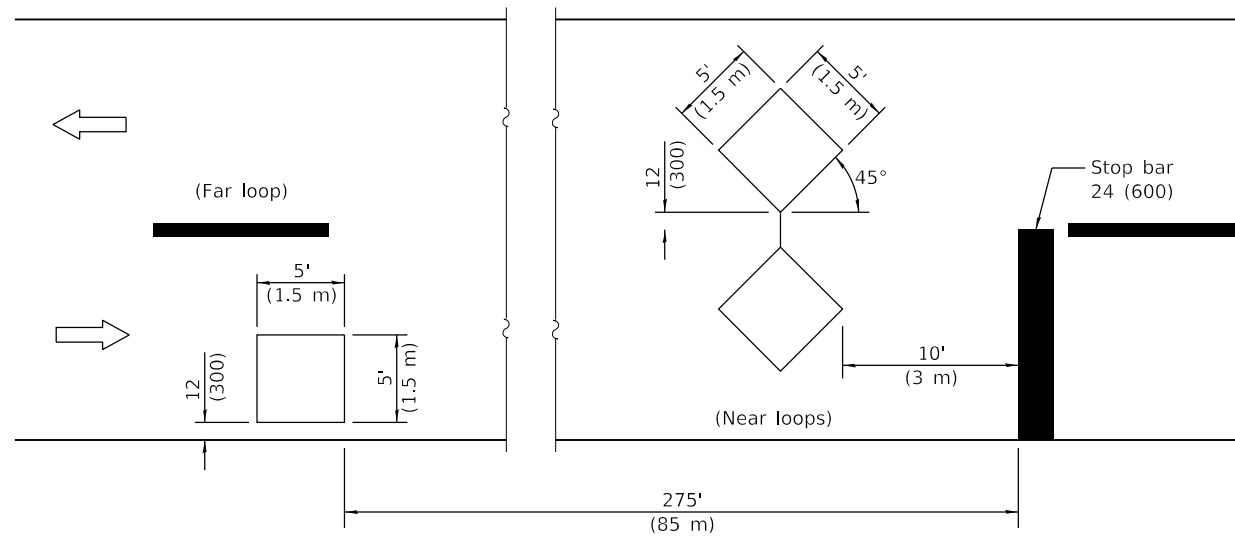

DETECTOR LOOPS

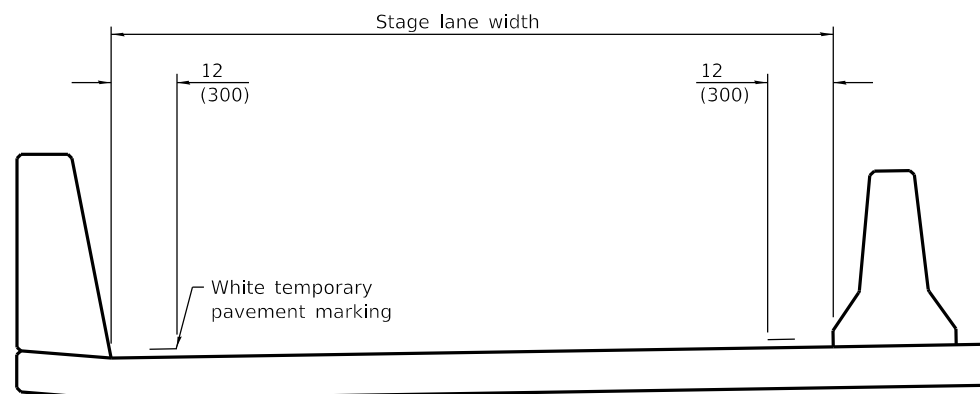

TEMPORARY PAVEMENT MARKING

TRAFFIC SIGNAL SEQUENCE						
PHASE	A			B		
INTERVAL	1	2	3	4	5	6
NORTHBOUND OR EASTBOUND	G	Y	R	R	R	R
SOUTHBOUND OR WESTBOUND	R	R	R	G	Y	R

TEMPORARY CONCRETE BARRIER	
NORMAL POSTED SPEED	TAPER RATIO
40 mph AND ABOVE	12:1
BELOW 40 mph	8:1

ADVISORY SPEED LIMIT	
NORMAL POSTED SPEED	ADVISORY SPEED
55 - 45 mph	40 mph
40 mph	35 mph
35 - 30 mph	30 mph

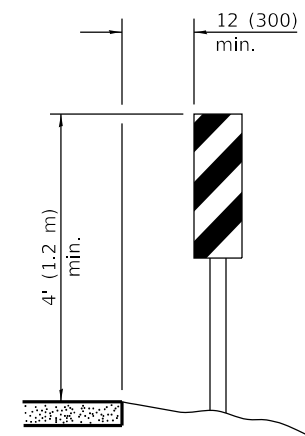

VERTICAL PANELS

(Post mounted, one each side)

GENERAL NOTES

This Standard is used where, at any time, any vehicle, equipment, workers, or their activities will encroach on one lane of a bridge. Traffic signals and a positive barrier are required.

Traffic signals shall be operational only when all traffic controls are in place. When traffic signals are not in operation, flaggers shall be used and traffic control shall conform to Standard 701201 or 701206.

Temporary concrete barrier shall be according to Standard 704001.

Existing or temporary pavement markings shall be on both sides of open lane from stop bar to stop bar.

All dimensions are in inches (millimeters) unless otherwise shown.

**LANE CLOSURE, 2L, 2W,
BRIDGE REPAIR WITH BARRIER**

(Sheet 2 of 2)

STANDARD 701321-18

Illinois Department of Transportation

PASSED January 1, 2020

 ENGINEER OF SAFETY PROG. AND ENGINEERING

APPROVED January 1, 2020



 ENGINEER OF DESIGN AND ENVIRONMENT

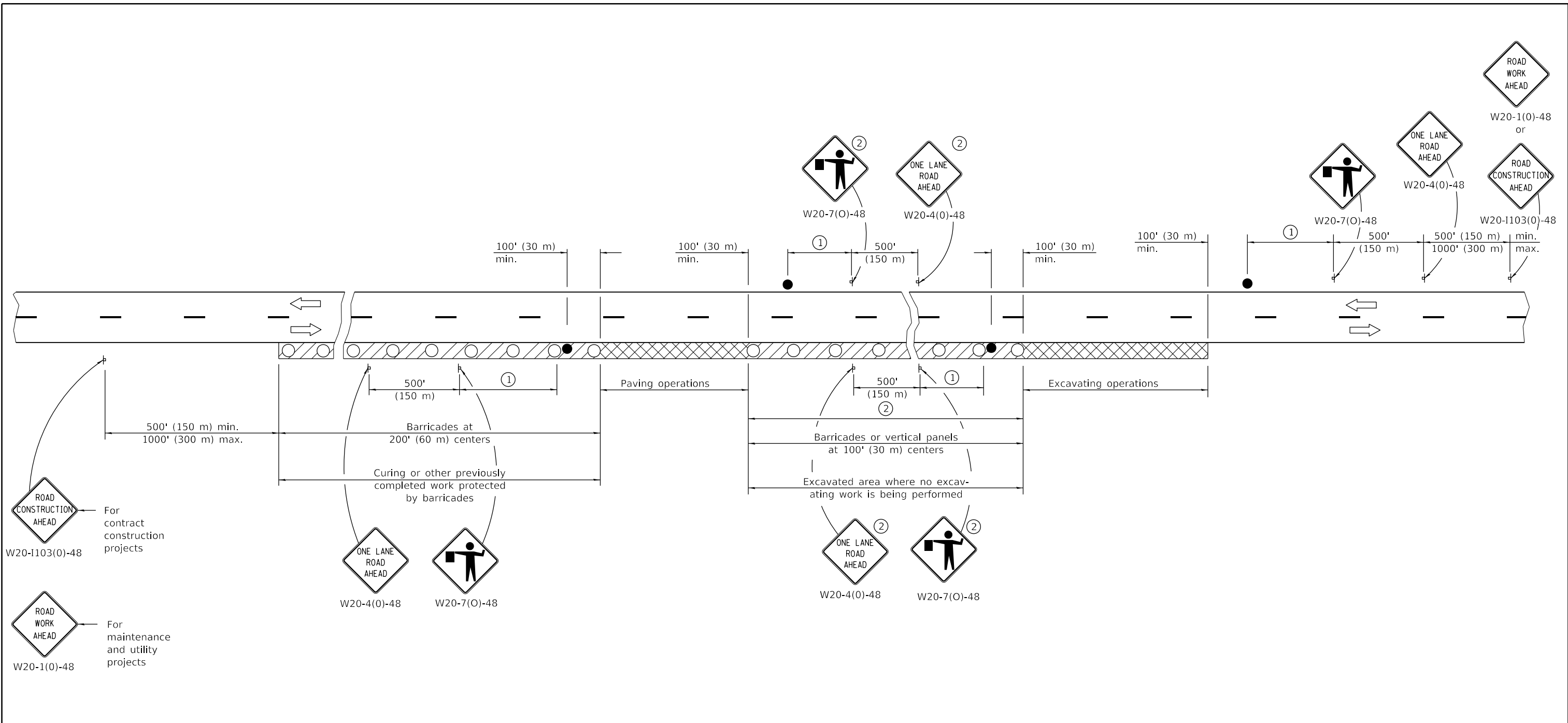

ISSUED 1-1-97







 For contract construction projects
 W20-1103(0)-48

 For maintenance and utility projects
 W20-1(0)-48

 W20-4(0)-48
 W20-7(0)-48

 W20-4(0)-48
 W20-7(0)-48

SYMBOLS

-  Work area
-  Active Work area
-  Sign
-  Barricade, drum, or vertical panels
-  Flagger with traffic control sign

- ① Minimum distance is 200' (60 m). Maximum distance to be determined by the Engineer but in no case to exceed the length of ½ day's normal operation or 2 miles (3200 m) whichever is less.
- ② Signs are not required if distance between work operations is less than 2000' (600 m) unless restricted sight distance exists.

GENERAL NOTES

This Standard is used where at any time, any vehicle, equipment, workers or their activities will encroach on the pavement during widening operations.

Two flaggers are required for each separate operation.

All dimensions are in inches (millimeters) unless otherwise shown.

 Illinois Department of Transportation

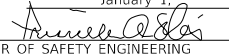
PASSED January 1, 2011

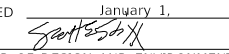
 ENGINEER OF SAFETY ENGINEERING

APPROVED January 1, 2011

 ENGINEER OF DESIGN AND ENVIRONMENT

ISSUED 1-1-97

DATE	REVISIONS
1-1-11	Revised flagger sign.
1-1-09	Switched units to English (metric).
	Corrected sign No.'s.

**LANE CLOSURE, 2L, 2W,
 PAVEMENT WIDENING,
 FOR SPEEDS ≥ 45 MPH**

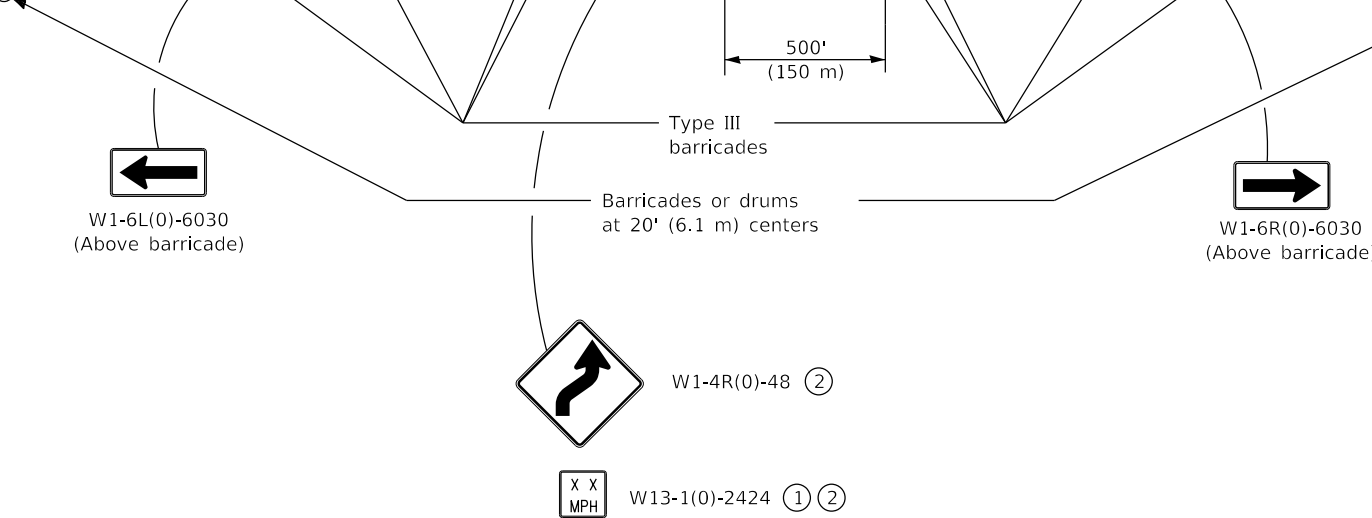
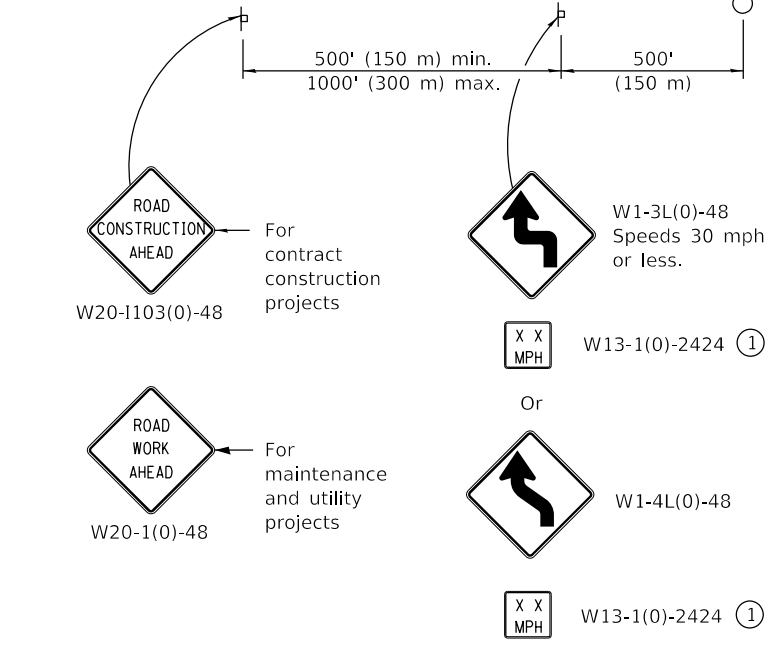
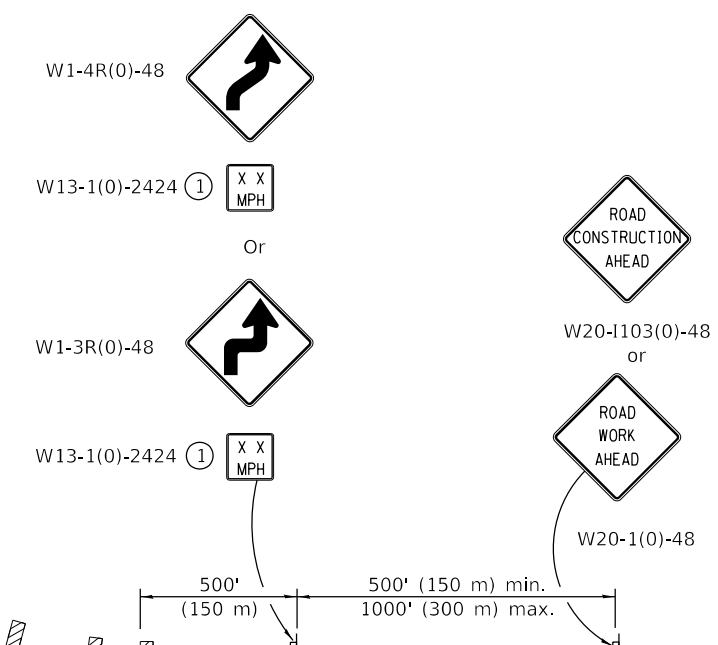
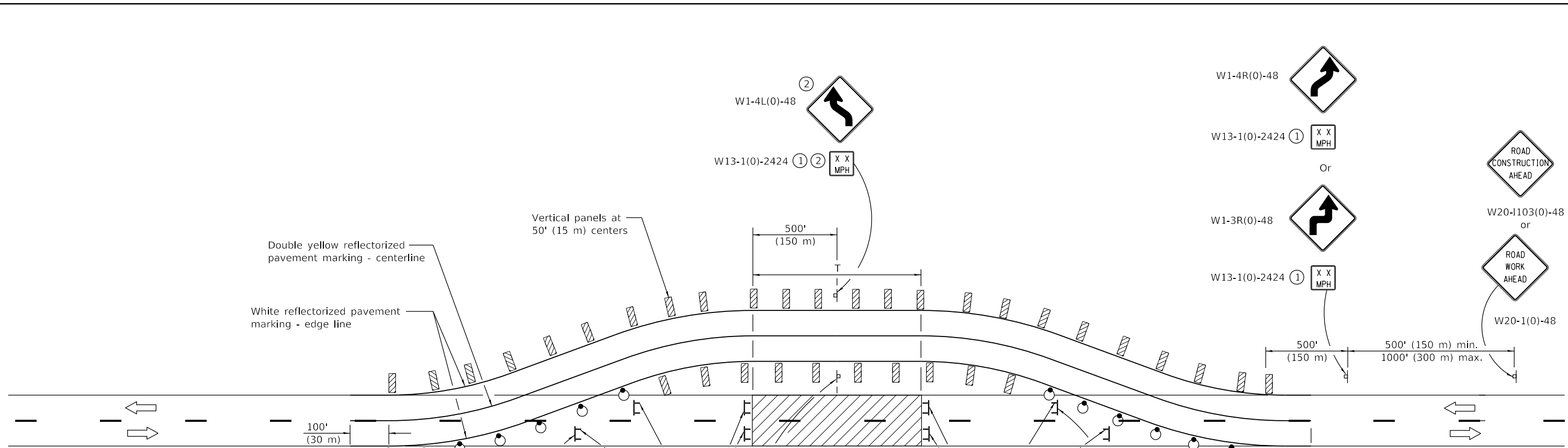
STANDARD 701326-04



TYPICAL APPLICATIONS
 Bridge construction
 Culvert construction

SYMBOLS

- Work area
- Sign
- Barricade or drum with steady burn bi-directional light
- Double vertical panel
- Type III barricade

- ① The advisory speed to be shown below the reverse curve (turn) signs shall be determined at the site and approved by the Engineer.
- ② These signs are not required when T is less than 500' (150 m).

GENERAL NOTES

This Standard is used where at any time, any vehicle, equipment, workers or their activities require the closure of both lanes and a temporary run-around is constructed.

Barricades or drums at 50' (15 m) centers shall be used in lieu of vertical panels on the detour where they are to be placed on new or existing pavement.

Where the tangent distance on the temporary run-around exceeds 600' (180 m), crystal delineators at 50' (15 m) centers may be substituted for the vertical panels, or the spacing between vertical panels may be increased to 100' (30 m) within the limits of the tangent.

All dimensions are in inches (millimeters) unless otherwise shown.

DATE	REVISIONS
1-1-18	Changed lights on drums to bi-directional.
1-1-11	Changed vertical panel to double vertical panel.

**LANE CLOSURE, 2L, 2W,
 WITH RUN-AROUND,
 FOR SPEEDS ≥ 45 MPH**

STANDARD 701331-05

Illinois Department of Transportation

PASSED January 1, 2018
Paul L. ...
 ENGINEER OF SAFETY PROG. AND ENGINEERING

APPROVED January 1, 2018
Maureen M. ...
 ENGINEER OF DESIGN AND ENVIRONMENT

ISSUED 1-1-97

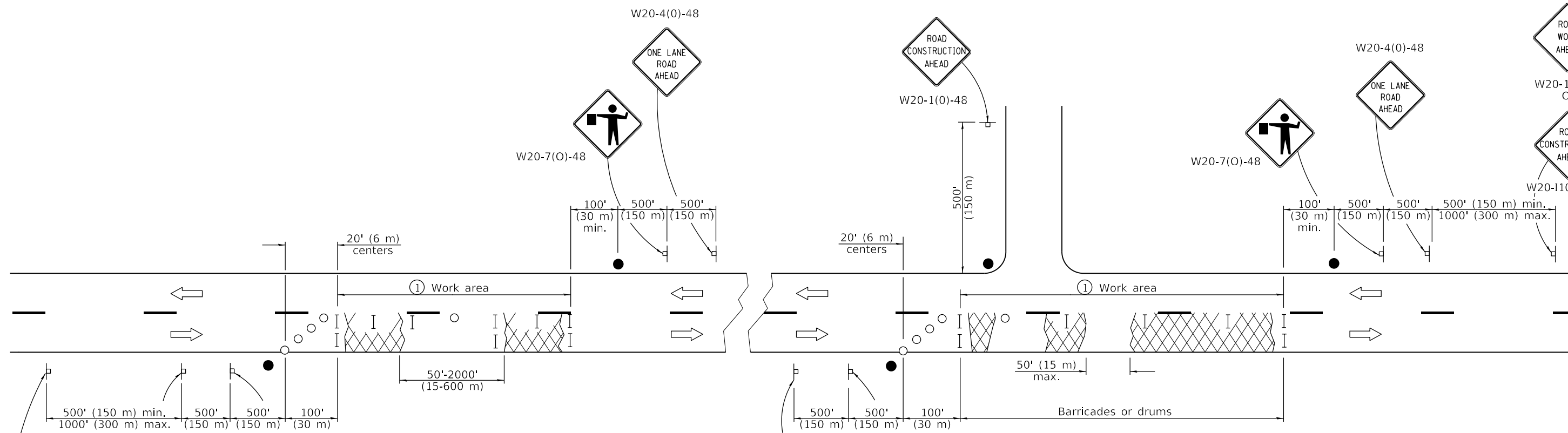

GENERAL NOTES

This Standard is used where at any time, any vehicle, equipment, workers or their activities will encroach in the area between the center line and a line 24 (600) outside the edge of the pavement.

Two flaggers shall be required for each separate lane closure. The flagger shall be a minimum of 200' (60 m) and a maximum of 1/2 day's operation beyond the flagger sign. When the distance between successive patches exceeds 2000' (600 m), additional flaggers, warning signs, and tapers shall be placed as shown.

Barricades/drums shall be placed at intervals not greater than 100' (30 m) or cones shall be placed at intervals not greater than 50' (15 m) centers throughout the work zone. When the spacing between open holes is greater than 50' (15 m), two barricades/drums shall be placed in front of each open hole and one on the backside close to the centerline. When the open hole is greater than 10' (3 m) parallel to the centerline, one barricade/drum shall be placed in each hole. For large holes, barricades/drums shall be placed at 50' (16 m) centers.

All dimensions are in inches (millimeters) unless otherwise shown.

SYMBOLS

- ▨ Patches
- ⊥ Sign
- Flagger with traffic control sign
- I Barricade or drum
- Cone, barricade or drum

① 1/2 mile (800 m) maximum

TYPICAL APPLICATIONS

Patching

For contract construction projects
 W20-1103(O)-48
 Or
 For maintenance and utility projects
 W20-1(O)-48

Illinois Department of Transportation

APPROVED January 1, 2019
Cynthia Watt
 ENGINEER OF SAFETY PROG. AND ENGINEERING

APPROVED January 1, 2019
Joe E. ...
 ENGINEER OF DESIGN AND ENVIRONMENT

ISSUED 1-1-97

DATE	REVISIONS
1-1-19	Revised device spacing in taper.
1-1-11	Revised flagger sign.

**LANE CLOSURE, 2L, 2W,
 WORK AREAS IN SERIES,
 FOR SPEEDS ≥ 45 MPH**

STANDARD 701336-07

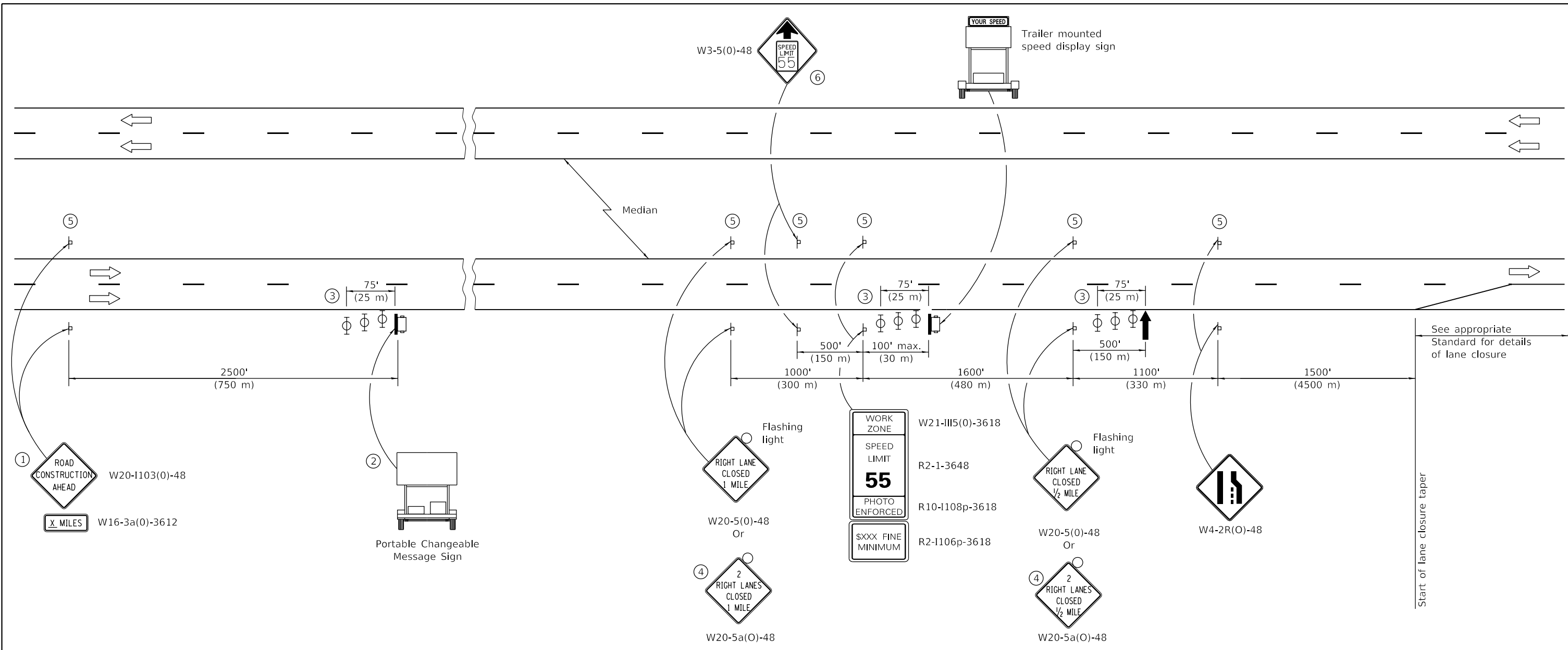

See appropriate Standard for details of lane closure

Start of lane closure taper

SYMBOLS

- ↑ Arrow board
- ☐ Trailer mounted sign
- ⊥ Sign
- ⊕ Type II barricade, drum, or vertical barricade with monodirectional flashing light

- ① The Road Construction Ahead sign shall be located 3 to 5 miles in advance of the project limits.
- ② The message board shall be used to display status of lanes within the project. The primary messages shall be:
 "Right Lane Closed" / " x Miles Ahead"
 "Left Lane Closed" / " x Miles Ahead"
 "All Lanes Open"
- ③ Three, Type II barricades, drums, or vertical barricades at 25' (8 m) centers.
- ④ This sign shall be used when 2 lanes are closed.
- ⑤ This sign shall be omitted when median width is less than 10' (3 m).
- ⑥ This sign shall only be used if the existing speed limit is greater than 65 mph.

GENERAL NOTES

This standard is used where at any time a lane is closed on a freeway/expressway. When the left lane is closed, LEFT LANE CLOSED signs shall be substituted for the RIGHT LANE CLOSED signs.

The first sign and the message board are stationary.

The last four signs and arrow board shall be moved as necessary to maintain the required distance from the start of the lane closure taper(s).

All dimensions are in inches (millimeters) unless otherwise shown.

Illinois Department of Transportation

PASSED January 1, 2022
Cynthia Watt
 ENGINEER OF SAFETY PROG. AND ENGINEERING

APPROVED January 1, 2022
Joe E. ...
 ENGINEER OF DESIGN AND ENVIRONMENT

ISSUED 4-1-04

DATE	REVISIONS
1-1-22	Corrected work zone speed limit sign number.
1-1-21	Removed Work Zone Public Information sign and its note.
	Revised stationary sign gen. note.

**APPROACH TO
LANE CLOSURE,
FREEWAY/EXPRESSWAY**

STANDARD 701400-11

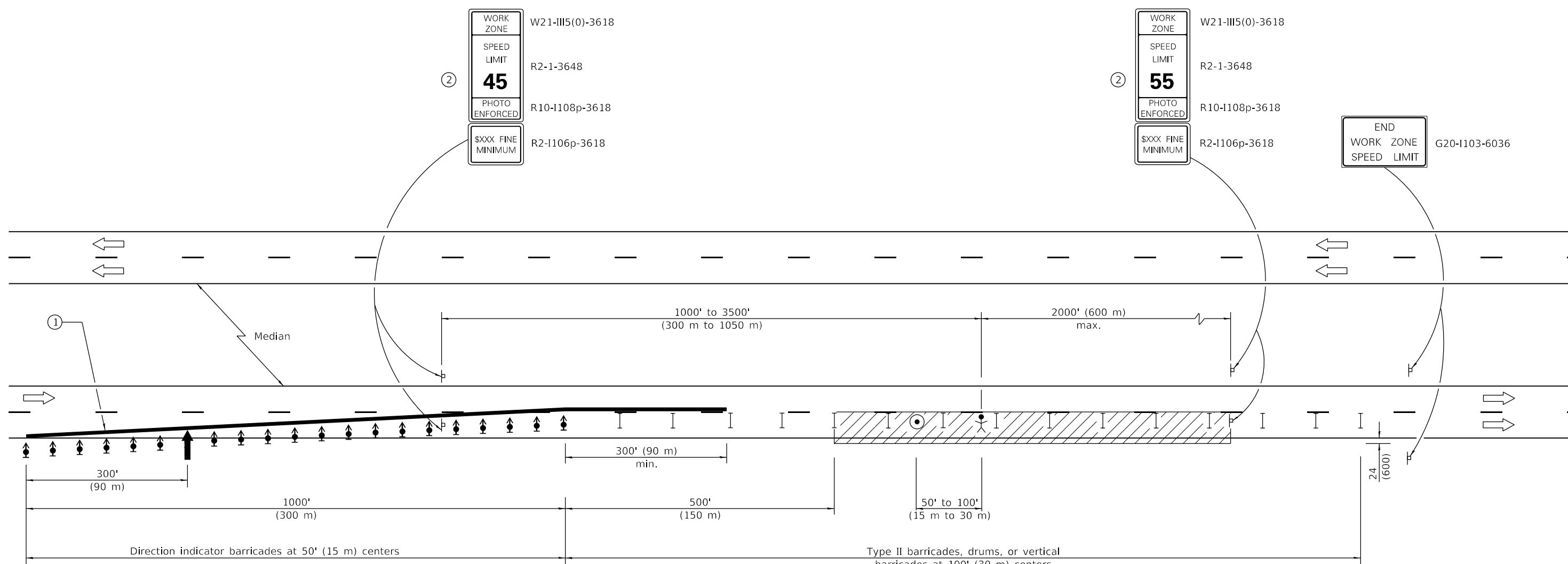

See Standard 701400 for approach
Start of lane closure taper

SYMBOLS

- Arrow board
- Work area
- Worker
- Sign
- Direction indicator barricade with steady burn monodirectional light
- Type II barricade, drum, or vertical barricade
- Spotter

- ① ReflectORIZED temporary pavement marking tape shall be placed throughout the taper and for 300' (90 m) along-side the work area when the closure time is greater than fourteen days. The edge line shall be white for right lane closure and yellow for left lane closures.
- ② Work Zone speed limit signs shall be moved as necessary to maintain the required spacing between the signs and the workers in each separate work activity. Work Zone Speed Limit 55 Photo Enforced sign shall be omitted when the work area dictates placement of the sign array within 500' (150 m) of the End Work Zone Speed Limit Sign.

GENERAL NOTES

This Standard is used where at any time any vehicle, equipment, workers or their activities will encroach on the lane adjacent to the shoulder, or on the shoulder within 24 (600) of the edge of pavement.

This Standard must always be used in combination with Standard 701400.

This Standard also applies when work is being performed in the left lane. Under these conditions, the setup would be a mirror image to what is shown.

A check barricade shall be placed in the middle of the closed lane and at the shoulder at 1000' (300 m) centers.

All dimensions are in inches (millimeters) unless otherwise shown.

Illinois Department of Transportation

APPROVED January 1, 2022
Cynthia Watt
ENGINEER OF SAFETY PROG. AND ENGINEERING

APPROVED January 1, 2022
Joe E. ...
ENGINEER OF DESIGN AND ENVIRONMENT

ISSUED 1-1-97

DATE	REVISIONS
1-1-22	Corrected work zone speed limit sign numbers.
1-1-19	Replaced flagger with spotter.
1-1-18	Omitted lights in tangent.

**LANE CLOSURE,
FREEWAY/EXPRESSWAY**

STANDARD 701401-13

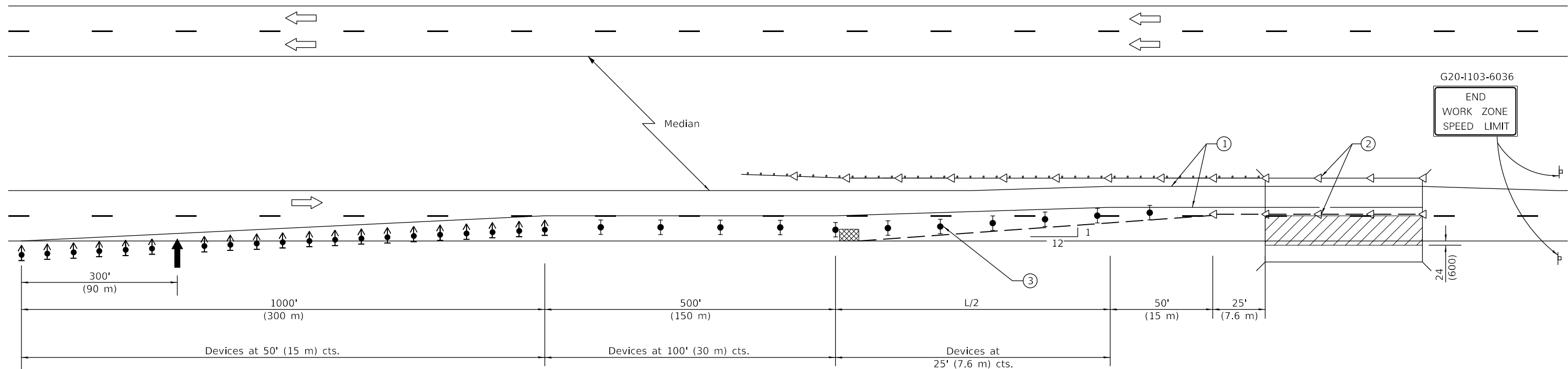

See Standard 701400 for approach
Start of lane closure taper

SYMBOLS

- Arrow board
- Work area
- Sign
- Direction indicator barricade with steady burn monodirectional light
- Type II barricade, drum, or vertical barricade with steady burn monodirectional light
- Temporary concrete barrier
- Monodirectional guardrail/barrier wall reflector
- Impact attenuator

- ① Temporary pavement marking tape shall be placed throughout the taper and along-side the work area. The right edge line shall be white and the left edge line shall be yellow.
- ② Guardrail/barrier wall reflectors at 25' (7.6 m). Markers on right shall be crystal and markers on left shall be amber. See Standards 704001 and 782006.
- ③ Vertical barricades shall not be used in lane shift taper.

GENERAL NOTES

This standard is used where at any time any vehicle, equipment, workers or their activities will encroach on the pavement or on the shoulder within 24 (600) of the edge of pavement for daylight operation exceeding one day and where temporary concrete barrier is utilized.

This Standard must always be used in combination with Standard 701400.

When work is being performed in the left lane, the set up would be a mirror image to what is shown.

Temporary concrete barrier shall be according to Standard 704001.

Calculate L as follows:

NORMAL POSTED SPEED	FORMULAS
	English (Metric)
45 mph (80 km/h) or more	$L=(W)(S)$ $L=0.65(W)(S)$

W = Width of offset in feet (meters).

S = Normal posted speed in mph (km/h).

All dimensions are in inches (millimeters) unless otherwise shown.

DATE	REVISIONS
1-1-17	Revised END WORK ZONE SPEED LIMIT sign from orange to white background.
4-1-16	Added reference to Standards 704001 and 782006 in note ②.

LANE CLOSURE, FREEWAY/EXPRESSWAY, WITH BARRIER

STANDARD 701402-12

Illinois Department of Transportation

PASSED January 1, 2017

 ENGINEER OF SAFETY PROG. AND ENGINEERING

APPROVED January 1, 2017

 ENGINEER OF DESIGN AND ENVIRONMENT

ISSUED 1-1-00

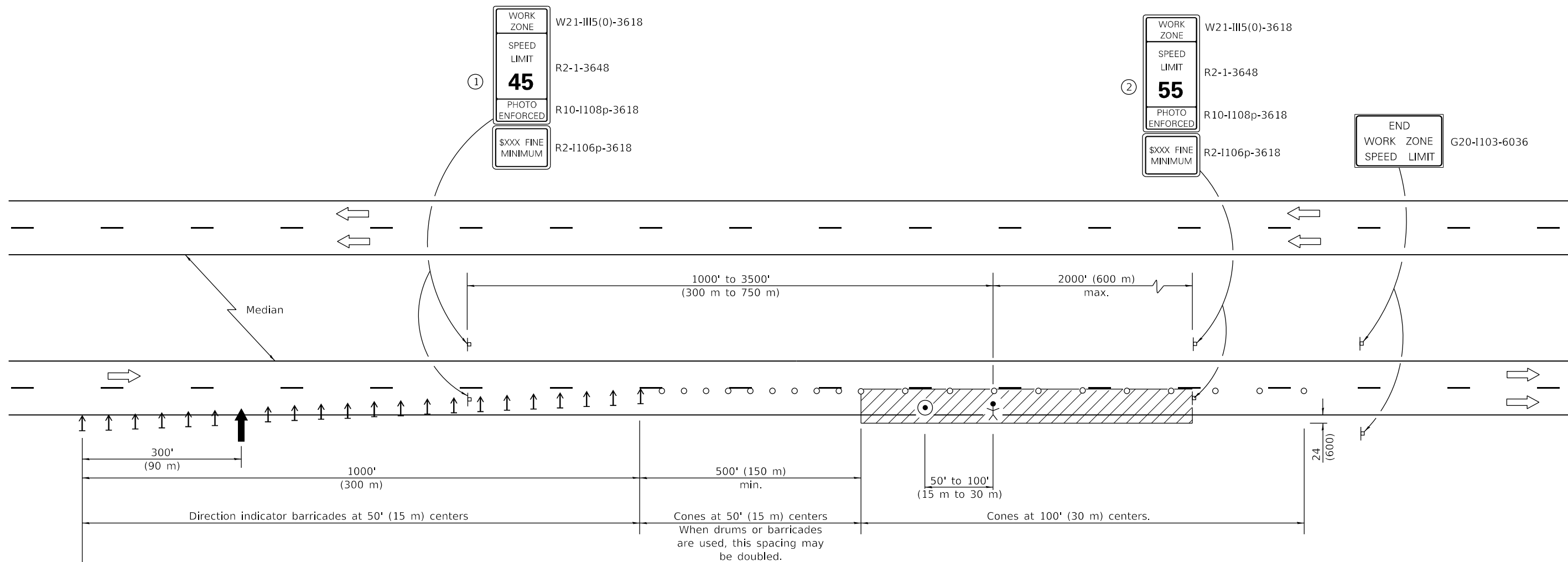

TYPICAL APPLICATIONS

Pavement patch
Utility operations
Bituminous resurfacing

SYMBOLS

- ↑ Arrow board
- ▨ Work area
- ⊙ Worker
- ⊥ Sign
- ↑ Direction indicator barricade
- Cone, drum or barricade
- ⊙ Spotter

- ① Work zone speed limit signs shall be moved as necessary to maintain the required spacing between the signs and the workers in each separate work activity.
- ② Work Zone Speed Limit 55 Photo Enforced sign shall be omitted when the work area dictates placement of the sign array within 500' (150 m) of the End Work Zone Speed Limit sign.

GENERAL NOTES

This Standard is used where at any time, any vehicle, equipment, workers or their activities will encroach on the lane adjacent to the shoulder, or on the shoulder within 24 (600) of the edge of pavement for daylight operation.

This Standard must always be used in combination with Standard 701400.

This Standard also applies when work is being performed in the left lane. Under these conditions, the set up would be a mirror image to what is shown.

All dimensions are in inches (millimeters) unless otherwise shown.

DATE	REVISIONS
1-1-22	Corrected work zone speed limit sign numbers.
1-1-19	Replaced flagger with spotter.
1-1-17	Revised END WORK ZONE SPEED LIMIT sign from orange to white background.

**LANE CLOSURE,
FREEWAY/EXPRESSWAY,
DAY OPERATIONS ONLY**

STANDARD 701406-13

Illinois Department of Transportation

APPROVED January 1, 2022
Cynthia Datt
ENGINEER OF SAFETY PROG. AND ENGINEERING

APPROVED January 1, 2022
J. E. Egan
ENGINEER OF DESIGN AND ENVIRONMENT

ISSUED 1-1-97

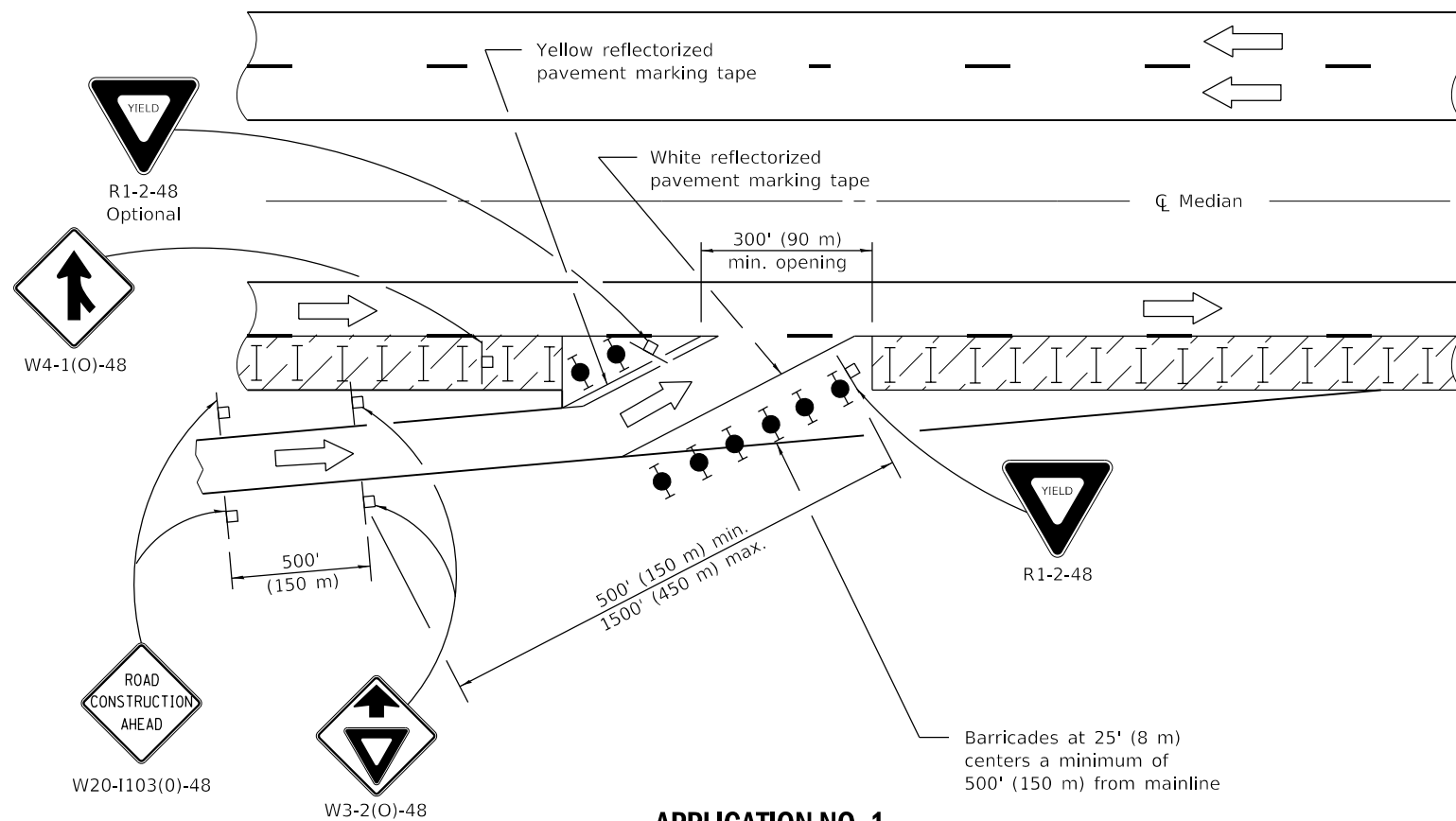

APPLICATION NO. 1

Application No. 1 depicts a modified entrance ramp. This method shall be utilized whenever existing entrance tapers cannot be retained due to the close proximity of the work zone. The entrance location may be shifted, with the approval of the Engineer, to perform work in the entrance area. Application No. 2 shall be put into effect as soon as possible.

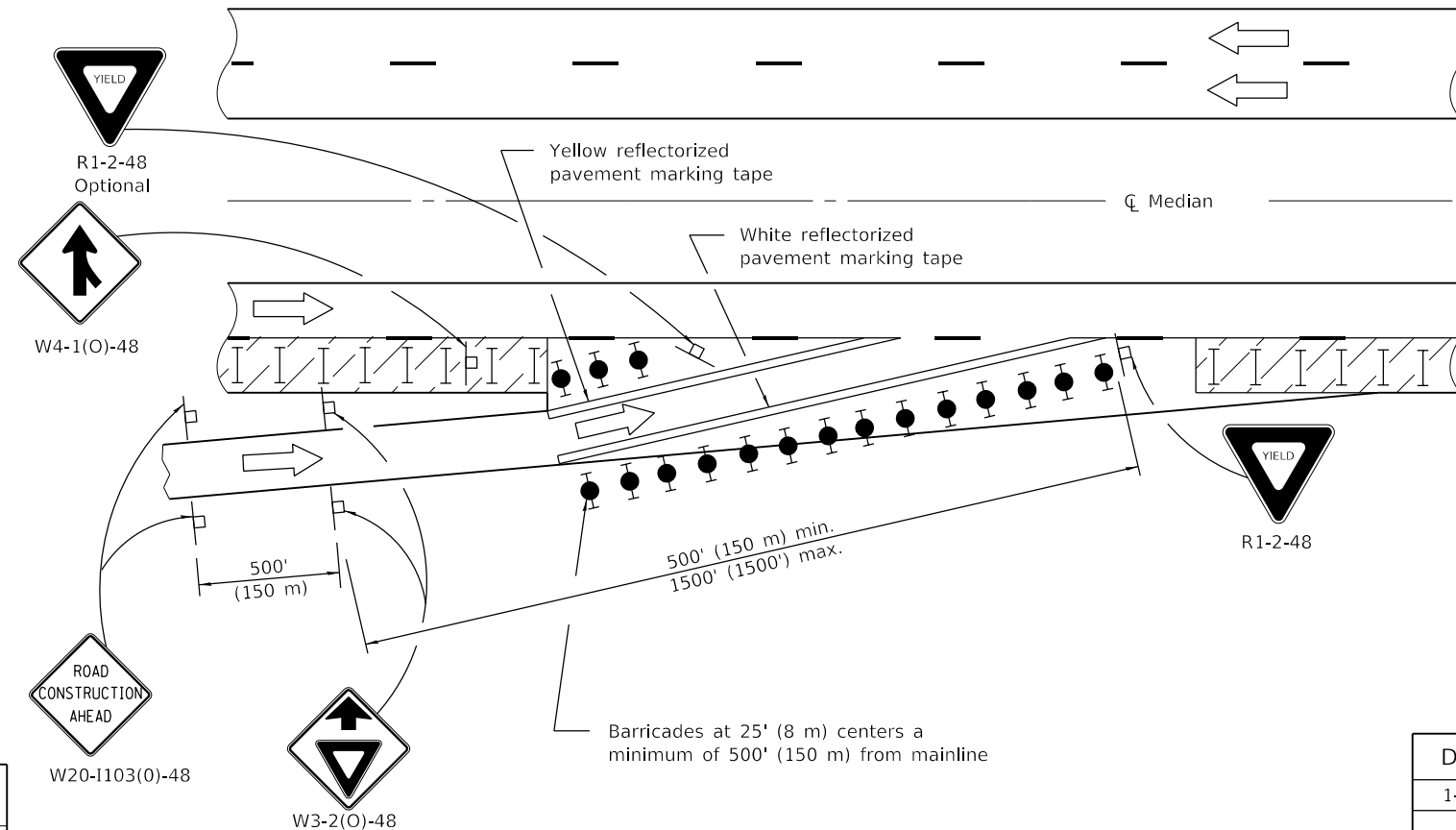

APPLICATION NO. 2

Application No. 2 depicts a shortening of the normal entrance ramp. This method shall be used whenever the existing geometrics can be retained. Consideration should be given to the entering motorists' line of sight, through, between, or over the delineation devices.

- SYMBOLS**
- Work area
 - Sign
 - Type II barricades or drums with steady burning monodirectional light
 - Type II barricades or drums
 - Drums with steady burning monodirectional light

- GENERAL NOTES**
- This Standard is used where, at any time any vehicle, equipment, workers or their activities require a lane closure in close proximity of an exit or entrance ramp and supplements other traffic control Standards for lane closures.
- These applications also apply when work is being performed in the left lanes and the ramps enter and exit on the left. Under these conditions, the Exit sign arrow and the Side road symbol sign shall be changed.
- Cones may be utilized during daylight operations, at one half the spacing of drums/barricades.
- Use of these APPLICATION NO. 1 and APPLICATION NO. 3 shall be limited to five days per location.
- When work does not exceed five days, pavement marking tape may be omitted.
- All dimensions are in inches (millimeters) unless otherwise shown.

DATE	REVISIONS
1-1-15	Revised gen. notes to limit App's 1 and 3 to five days, omit pvt. tape for ≤ 5 days.
1-1-12	Revised merge sign to agree with MUTCD. Dimensioned EXIT OPEN AHEAD sign.

LANE CLOSURE, MULTILANE, AT ENTRANCE OR EXIT RAMP, FOR SPEEDS ≥ 45 MPH
 (Sheet 1 of 2)
STANDARD 701411-09

Illinois Department of Transportation

PASSED January 1, 2015
 ENGINEER OF SAFETY ENGINEERING

APPROVED January 1, 2015
 ENGINEER OF DESIGN AND ENVIRONMENT

ISSUED 1-1-97

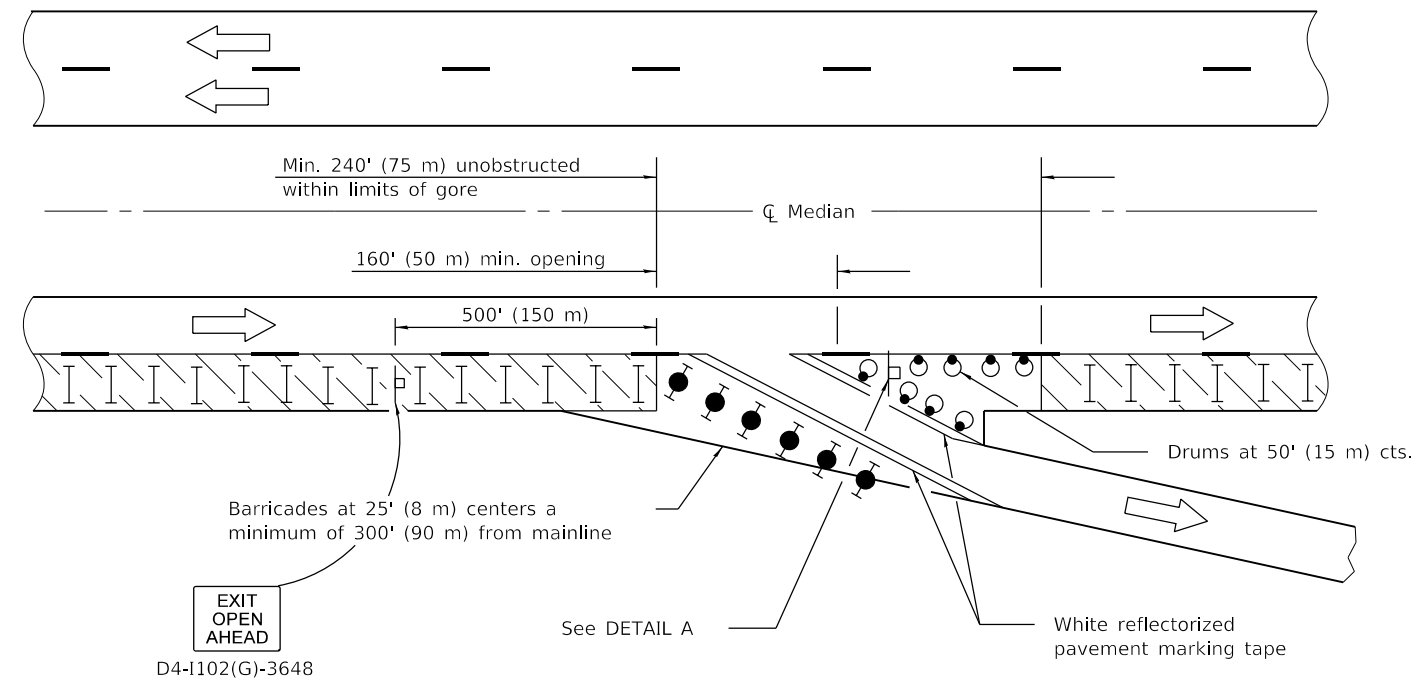

APPLICATION NO. 3

Application No. 3 depicts a modified exit ramp. The channelizing devices shall provide a clearly defined path for the exiting motorists. The minimum dimensions shown shall be increased as soon as the progress of the work will permit. The open portion of the ramp may be shifted, with the approval of the Engineer, to perform work in stages on the area adjacent to the ramp exit. Application No. 4 shall be put into effect as soon as possible.

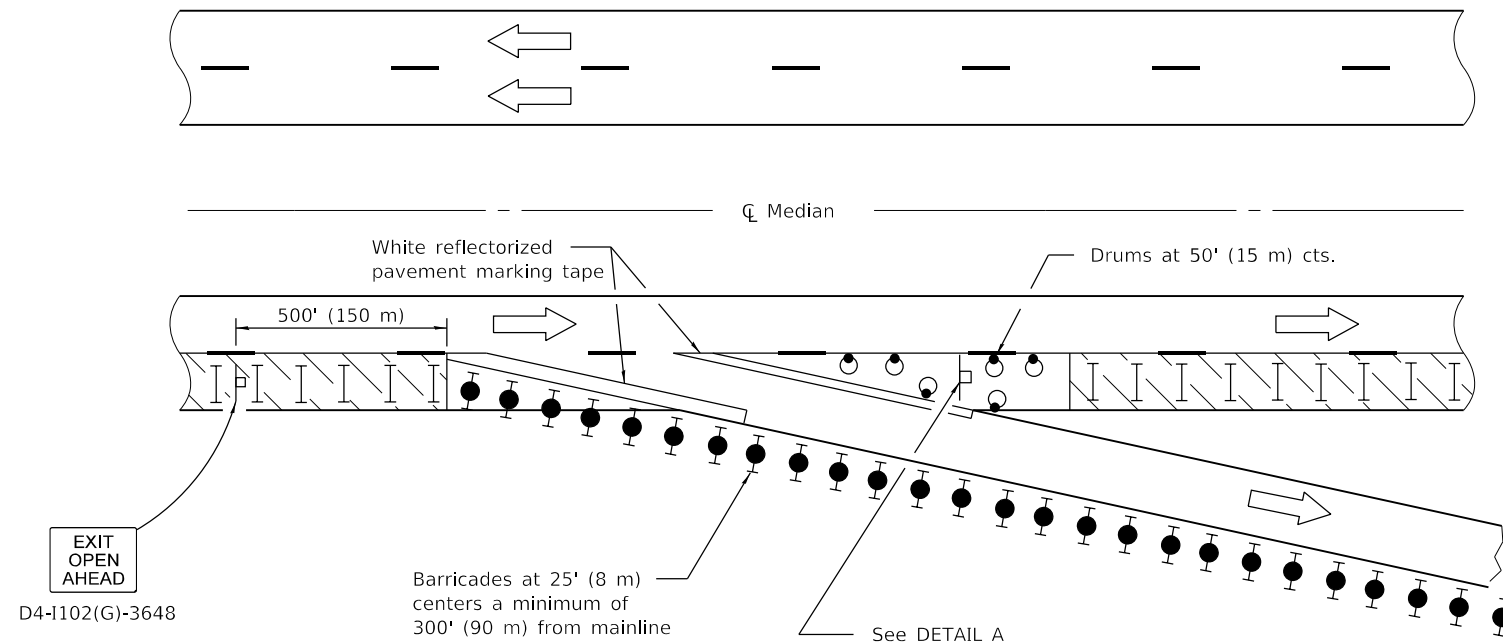

APPLICATION NO. 4

Application No. 4 depicts an extension of the normal exit ramp. This method shall be used whenever existing geometrics can be retained. Consideration should be given to the exiting motorist's line of sight through, between or over the delineation devices.

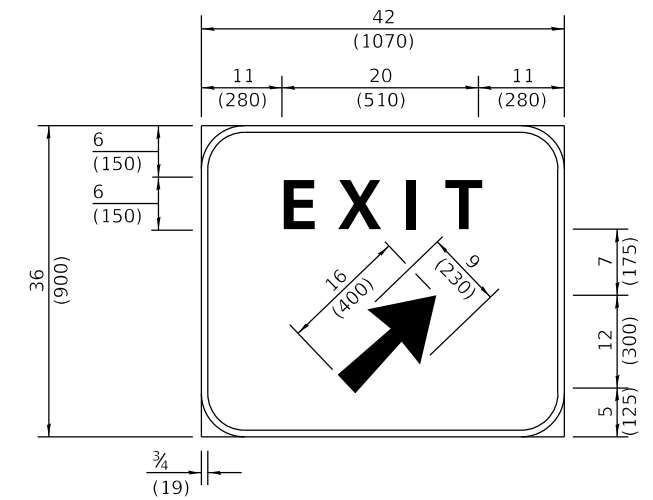

DETAIL A

(To be utilized where distance between the two rows of channelizing devices is 6' (1.8 m) in width.)

Illinois Department of Transportation

PASSED January 1, 2015

ENGINEER OF SAFETY ENGINEERING

APPROVED January 1, 2015

ENGINEER OF DESIGN AND ENVIRONMENT

ISSUED 1-1-97

**LANE CLOSURE, MULTILANE,
AT ENTRANCE OR EXIT RAMP,
FOR SPEEDS ≥ 45 MPH**

(Sheet 2 of 2)

STANDARD 701411-09

See Standard 701400 for approach
Start of lane closure taper

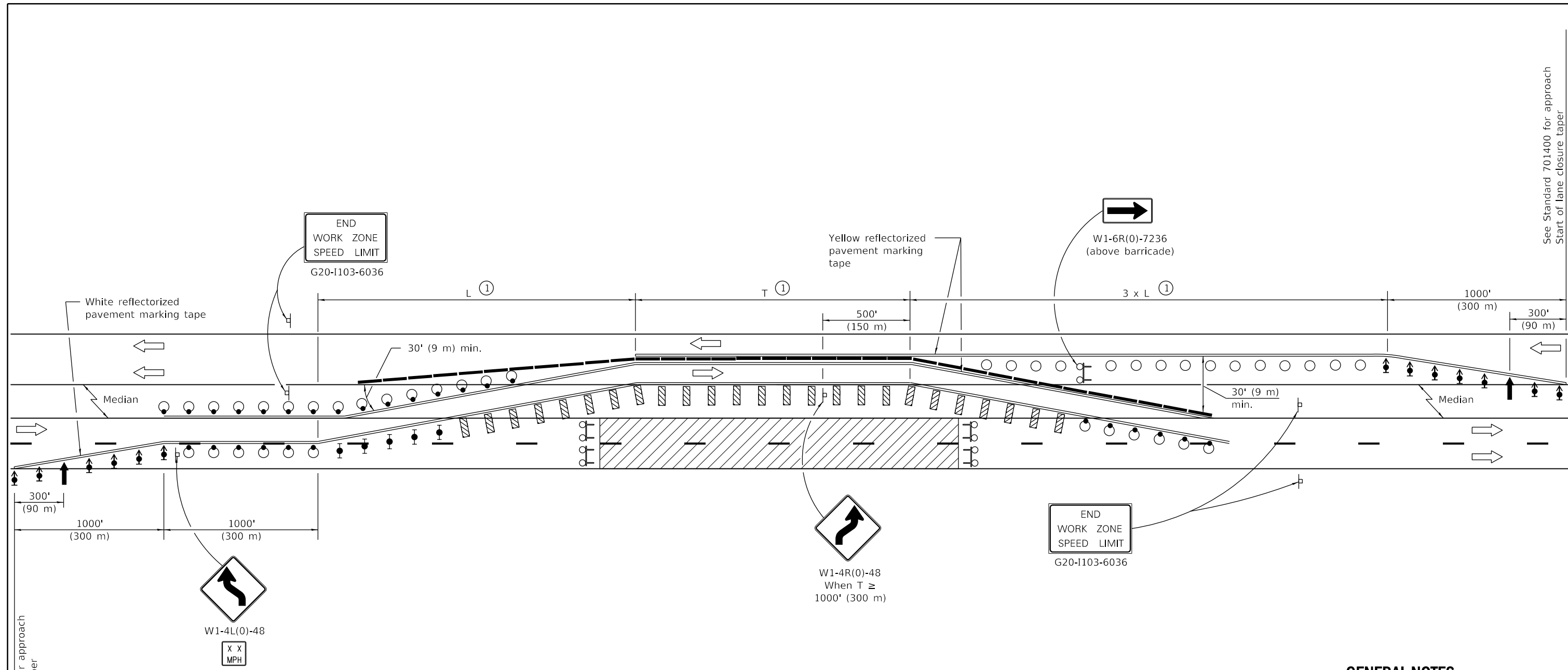

See Standard 701400 for approach
Start of lane closure taper

SYMBOLS

- Arrow board
- Work area
- Sign
- Direction indicator barricade with steady burn monodirectional light
- Type II barricade with steady burn monodirectional light
- Drum with steady burn monodirectional light
- Vertical Panel
- Type III barricade with flashing lights
- Temporary concrete barrier
- Drum

① "L" and "T" shall be as shown on the plan details.

GENERAL NOTES

This Standard is used where at any time, any vehicle, equipment, workers or their activities require the closure of two adjacent lanes and a temporary crossover is provided by making use of one lane of pavement normally used by opposing flow of traffic and concrete barrier is used to separate the opposing traffic.

This Standard must always be used in combination with Standard 701400.

All barricades, drums, and vertical panels shall be at 50 ft. (15 m) centers.

Temporary concrete barrier shall be according to Standard 704001.

All dimensions are in inches (millimeters) unless otherwise shown.

DATE	REVISIONS
1-1-18	Omitted lights on drums for the '3 x L' tangent.
1-1-17	Revised END WORK ZONE SPEED LIMIT sign from orange to white background.

**LANE CLOSURE,
FREEWAY / EXPRESSWAY,
WITH CROSSOVER AND BARRIER**

STANDARD 701416-11

Illinois Department of Transportation

PASSED January 1, 2018
Paul L. ...
ENGINEER OF SAFETY PROG. AND ENGINEERING

APPROVED January 1, 2018
Maureen M. ...
ENGINEER OF DESIGN AND ENVIRONMENT

ISSUED 1-1-97

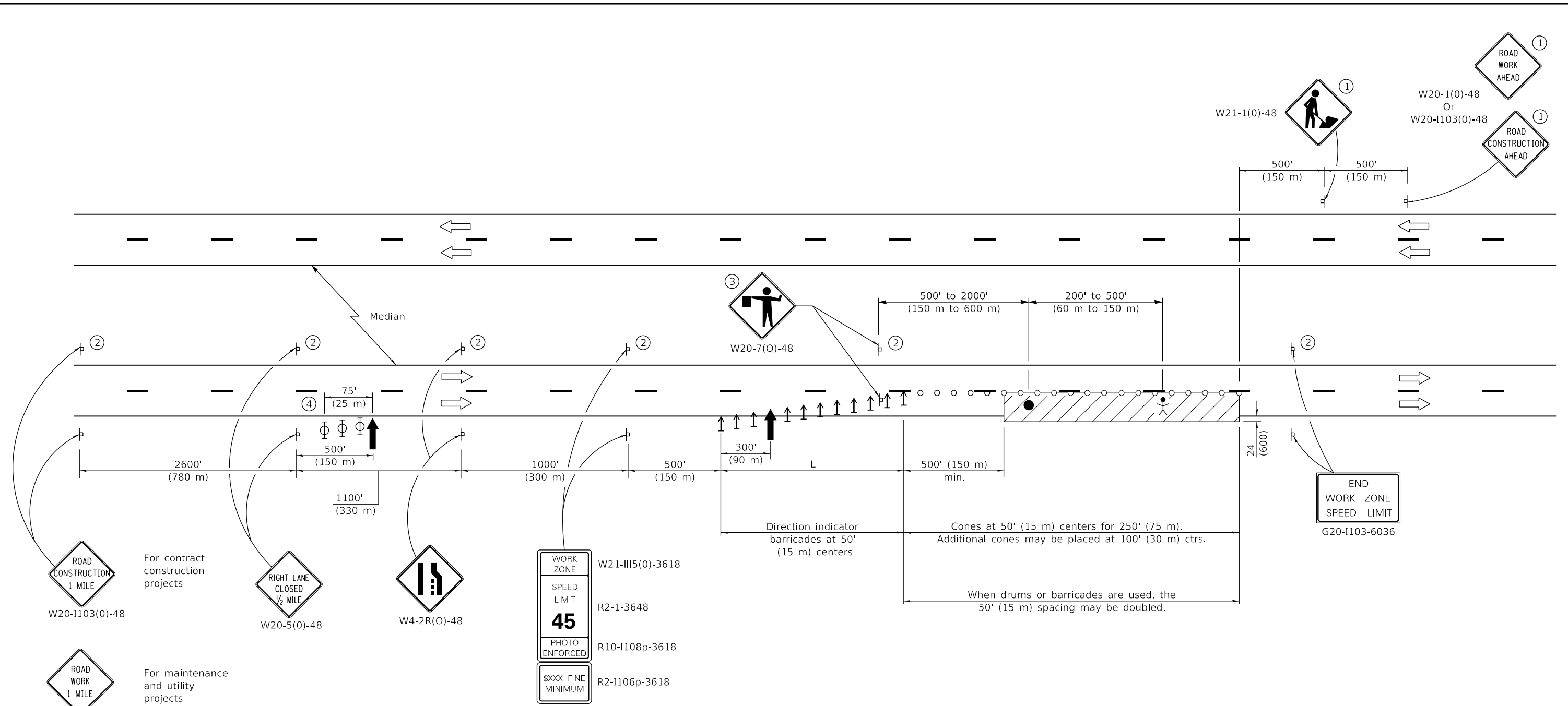

ROAD CONSTRUCTION 1 MILE
W20-1103(0)-48

For contract construction projects

RIGHT LANE CLOSED 1/2 MILE
W20-5(0)-48

W4-2R(0)-48

ROAD WORK 1 MILE
W20-1(0)-48

For maintenance and utility projects

WORK ZONE W21-III5(0)-3618
SPEED LIMIT 45 R2-1-3648
PHOTO ENFORCED R10-1108p-3618
\$XXX FINE MINIMUM R2-1106p-3618

L = lane width X taper ratio	
Normal Posted Speed	Taper Ratio
mph	
55	55/1
45	45/1

SYMBOLS

- ↑ Arrow board
- ▨ Work area
- ⊥ Sign
- ↑ Direction indicator barricade
- Cone, drum or barricade
- Flagger with traffic control sign
- ⚧ Worker
- ⊕ Type II barricade, drum, or vertical barricade with monodirectional flashing light

TYPICAL APPLICATIONS

Pavement patch
Utility operations
Bituminous resurfacing

- ① Undivided roadway only with left lane closure in opposite direction.
- ② Omitted when median is less than 10' (3 m).
- ③ FLAGGER signs shall be moved as necessary to maintain the required spacing between the sign and each separate work activity.
- ④ Three Type II barricades, drums, or vertical barricades at 25' (8 m) centers.

GENERAL NOTES

This Standard is used where at any time, any vehicle, equipment, workers or their activities will encroach on the lane adjacent to the shoulder, or on the shoulder within 24 (600) of the edge of pavement.

This Standard also applies when work is being performed in the left lane. Under these conditions, LEFT LANE CLOSED signs shall be substituted for RIGHT LANE CLOSED signs. On undivided highways, signs shall be added in the opposite direction as shown.

All dimensions are in inches (millimeters) unless otherwise shown.

DATE	REVISIONS
1-1-17	Rev. END WORK ZONE SPEED LIMIT sign. Changed device spacing at first arr. brd.
1-1-15	Revised END WORK ZONE SPEED LIMIT sign dimensions.

LANE CLOSURE, MULTILANE, DAY OPERATIONS ONLY, FOR SPEEDS ≥ 45 MPH TO 55 MPH

STANDARD 701421-08

Illinois Department of Transportation

PASSED January 1, 2017
Paul L. ...
ENGINEER OF SAFETY PROG. AND ENGINEERING

ISSUED 4-1-04

APPROVED January 1, 2017
Maureen M. ...
ENGINEER OF DESIGN AND ENVIRONMENT

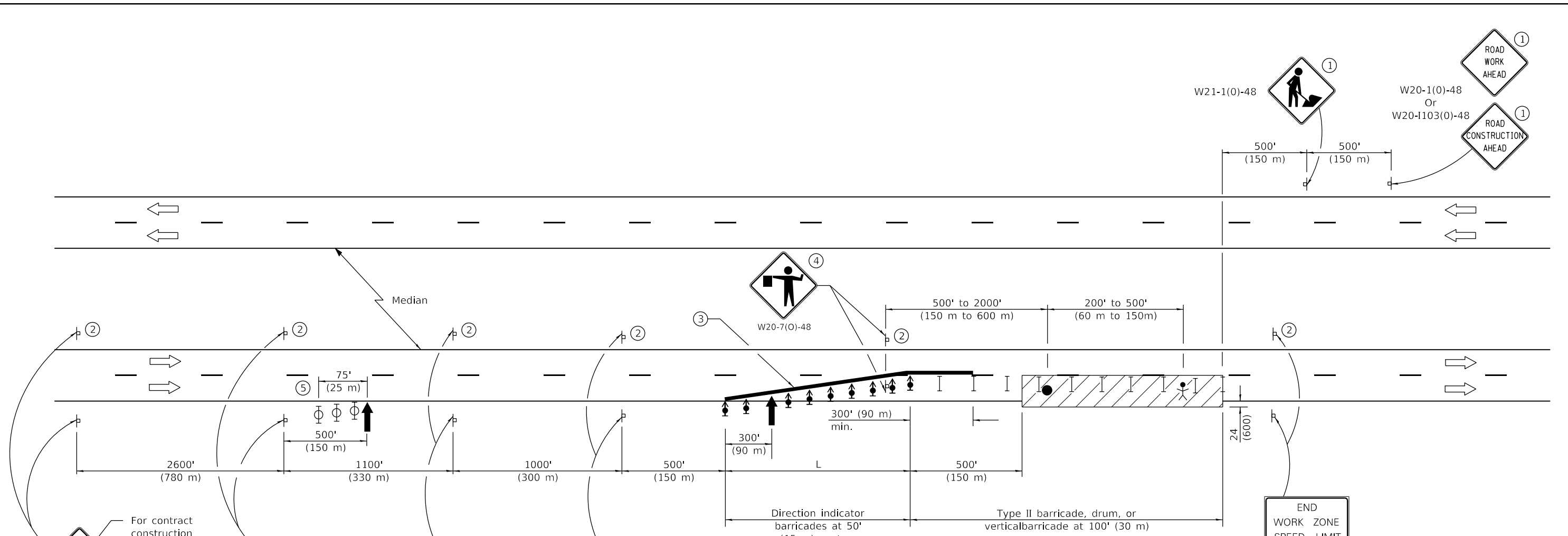

SYMBOLS

- Arrow board
- Work area
- Sign
- Direction indicator barricade with steady burn monodirectional light
- Type II barricade, drum, or vertical barricade
- Flagger with traffic control sign
- Worker
- Type II barricade, drum, or vertical barricade with monodirectional flashing light

- ① Undivided roadway only with left lane closure in opposite direction.
- ② Omitted when median is less than 10' (3 m).
- ③ ReflectORIZED temporary pavement marking tape shall be placed throughout the taper and for 300' (90 m) along-side the work area where the closure time is greater than fourteen days. The edge line shall be white for right lane closures and yellow for left lane closures.
- ④ FLAGGER signs shall be moved as necessary to maintain the required spacing between the sign and each separate work activity.
- ⑤ Three Type II barricades, drums, or vertical barricades at 25' (8 m) centers.

GENERAL NOTES

This standard is used where at any time any vehicle, equipment, workers or their activities will encroach on the lane adjacent to the shoulder, or on the shoulder within 24 (600) of the edge of pavement for daylight operation exceeding one day.

This standard also applies when work is being performed in the left lane. Under these conditions LEFT LANE CLOSED signs shall be substituted for RIGHT LANE CLOSED signs. On undivided highways, signs shall be added in the opposite direction as shown.

A check barricade shall be placed in the middle of the closed lane and at the shoulder at 1000' (300 m) centers.

All dimensions are in inches (millimeters) unless otherwise shown.

DATE	REVISIONS
1-1-18	Omitted lights in tangent.
1-1-17	Rev. END WORK ZONE SPEED LIMIT sign. Changed device spacing at first arr. brd.

**LANE CLOSURE,
MULTILANE, FOR
SPEEDS ≥ 45 MPH TO 55 MPH**

STANDARD 701422-10

Illinois Department of Transportation

PASSED January 1, 2018

ENGINEER OF SAFETY PROG. AND ENGINEERING

APPROVED January 1, 2018

ENGINEER OF DESIGN AND ENVIRONMENT

ISSUED 4-1-04

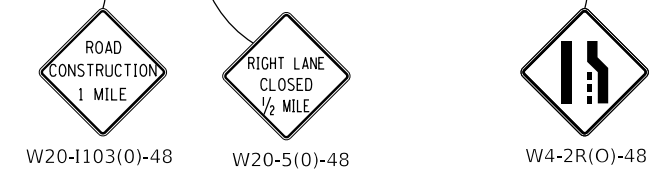
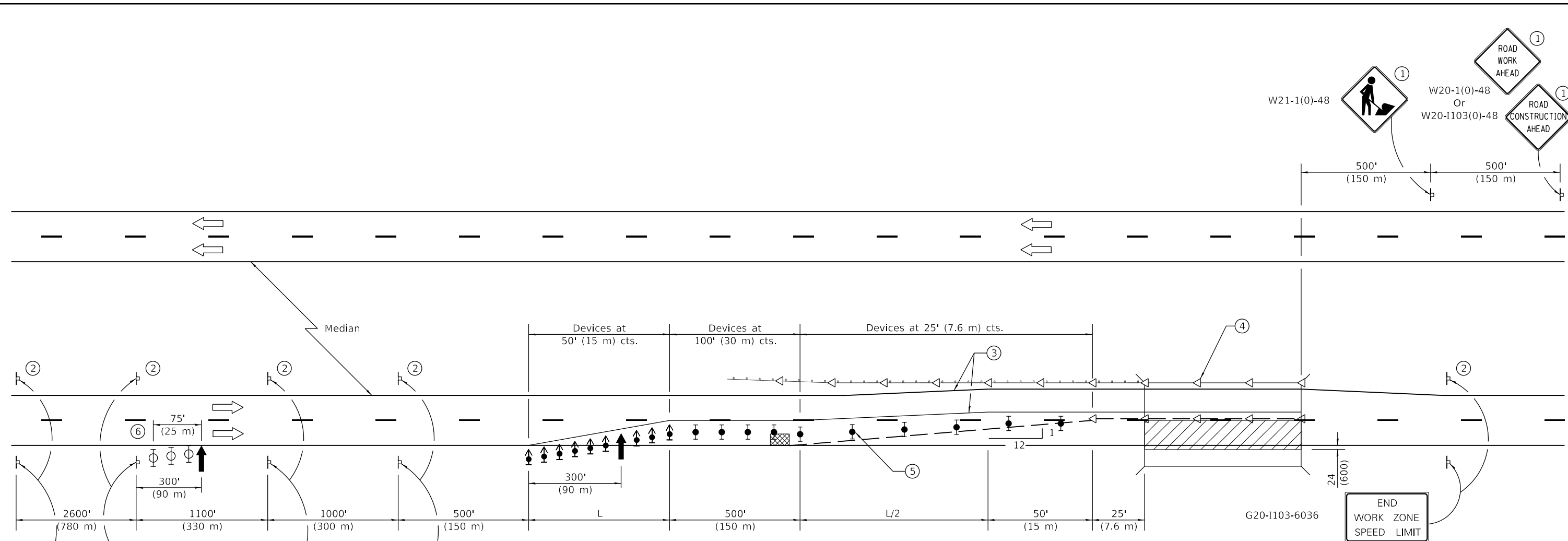

For contract construction projects



For maintenance and utility projects

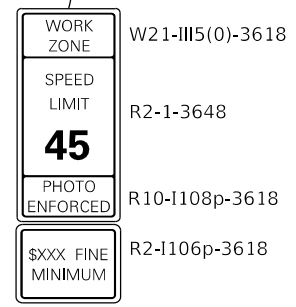

SYMBOLS

- Arrow board
- Work area
- Sign
- Direction indicator barricade with steady burn monodirectional light
- Type II barricade, drum, or vertical barricade with steady burn monodirectional light
- Temporary concrete barrier
- Monodirectional guardrail/barrier wall reflector
- Impact attenuator
- Type II barricade, drum, or vertical barricade with monodirectional flashing light

- ① Undivided roadway only with left lane closure in opposite direction.
- ② Sign in median may be omitted when median is less than 10' (3 m).
- ③ Temporary pavement marking tape shall be placed throughout the taper and along-side the work area. The right edge line shall be white and the left edge line shall be yellow.
- ④ Guardrail/barrier wall reflectors at 25' (7.6 m). Markers on right shall be crystal and markers on left shall be amber. See Standards 704001 and 782006.
- ⑤ Verticle barricades shall not be used in lane shift taper.
- ⑥ Three Type II barricades, drums, or vertical barricades at 25' (8 m) centers.

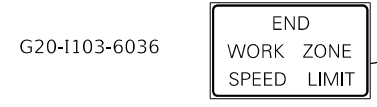
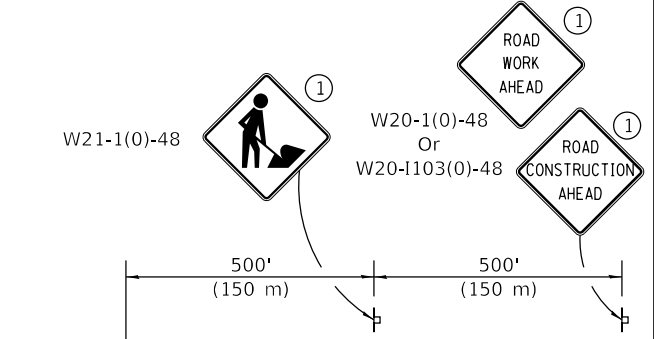

GENERAL NOTES

This standard is used where at any time any vehicle, equipment, workers or their activities will encroach on the pavement or on the shoulder within 24 (600) of the edge of pavement for daylight operation exceeding one day and where temporary concrete barrier is utilized.

When work is being performed in the left lane, the set up would be a mirror image to what is shown.

Calculate L as follows:

NORMAL POSTED SPEED	FORMULAS
45 mph (80 km/h) or more	English (Metric) $L=(W)(S)$ $L=0.65(W)(S)$

W = Width of offset in feet (meters).
S = Normal posted speed in mph (km/h).

All dimensions are in inches (millimeters) unless otherwise shown.

DATE	REVISIONS
1-1-17	Revised END WORK ZONE SPEED LIMIT sign. Changed device spacing at first arr. brd.
4-1-16	Corrected reference to standard in note ④.

LANE CLOSURE, MULTILANE, WITH BARRIER, FOR SPEEDS ≥ 45 MPH TO 55 MPH

STANDARD 701423-10

Illinois Department of Transportation

PASSED January 1, 2017

 ENGINEER OF SAFETY PROG. AND ENGINEERING

APPROVED January 1, 2017

 ENGINEER OF DESIGN AND ENVIRONMENT

ISSUED 1-1-00

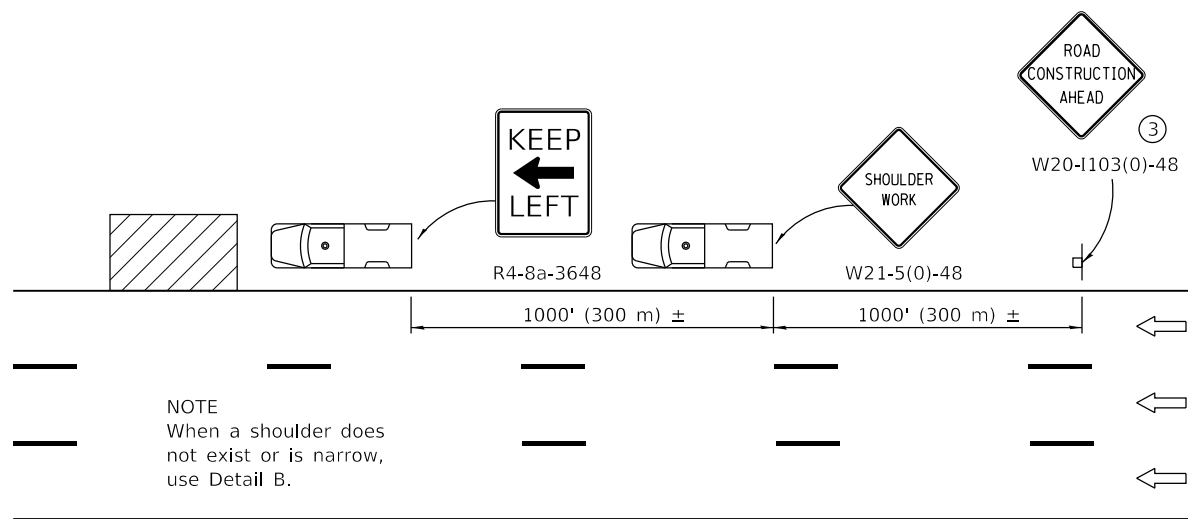

NOTE
When a shoulder does not exist or is narrow, use Detail B.

DETAIL A

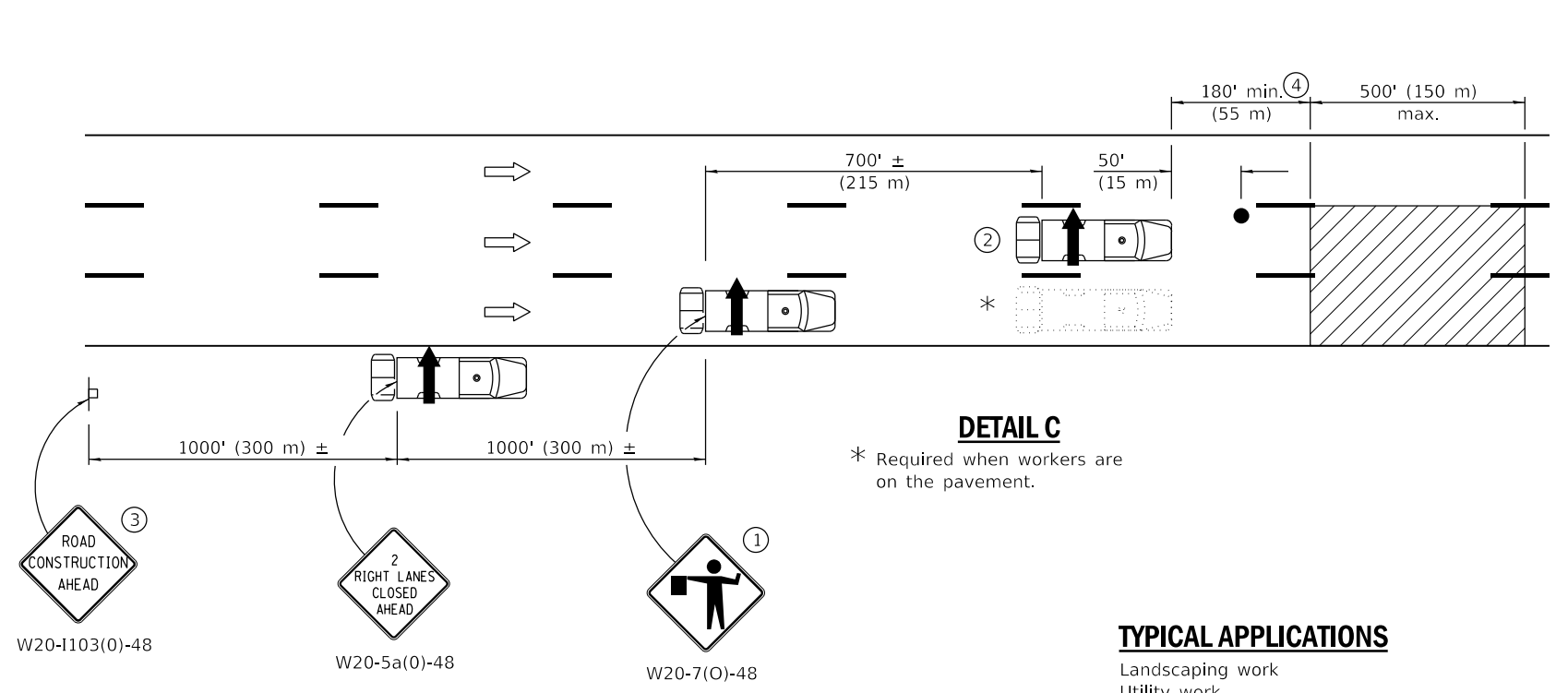

DETAIL C
* Required when workers are on the pavement.

TYPICAL APPLICATIONS

- Landscaping work
- Utility work
- Pavement marking
- Weed spraying
- Roadometer measurements
- Debris cleanup
- Crack pouring

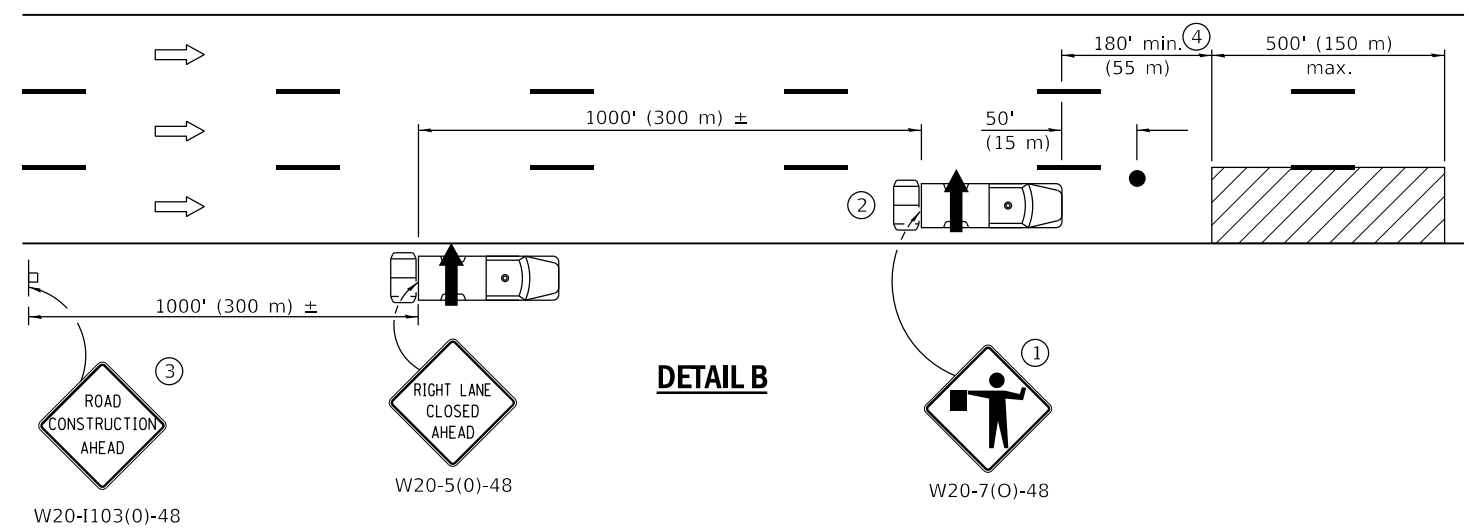

DETAIL B

- ① Flaggers are required when workers are on the pavement.
- ② For striping operations only. See sign arrow detail on this standard.
- ③ For stationary operations which are on the roadway or shoulder, greater than 15 minutes and up to 1 hour.
- ④ The distance between the work and the lead truck may vary according to terrain or paint/crack sealing drying time.



G20-1101-2430
(appropriate arrow)
② (when striping only)

GENERAL NOTES

This Standard is used where any vehicle, equipment, workers or their activities will require:
1) stationary operations up to 1 hour, or 2) a continuous or intermittent moving operation where the average speed of movement is greater than 1 mph (2 km/h).

This Standard is also applicable when work is being performed in the left lane(s) or on the median shoulder. Under these conditions, KEEP RIGHT signs shall be substituted for KEEP LEFT signs and arrow board indications shall be directed to the right.

All dimensions are in inches (millimeter) unless otherwise shown.

SYMBOLS

- Arrow board
- Work area
- Truck with flashing amber light
- Truck/Trailer mounted attenuator
- Flagger with traffic control sign
- Sign

Illinois Department of Transportation

PASSED January 1, 2017
Paul L. ...
ENGINEER OF SAFETY PROG. AND ENGINEERING

ISSUED 1-1-97

APPROVED January 1, 2017
Maureen M. ...
ENGINEER OF DESIGN AND ENVIRONMENT

DATE	REVISIONS
1-1-17	Revised 'NOTE' on DETAIL A to use DETAIL B in lieu of DETAIL C.
4-1-16	Added trailer option for attenuator symbol. Added note ④. Revised gen. notes.

LANE CLOSURE, MULTILANE, INTERMITTENT OR MOVING OPER., FOR SPEEDS ≥ 45 MPH

STANDARD 701426-09

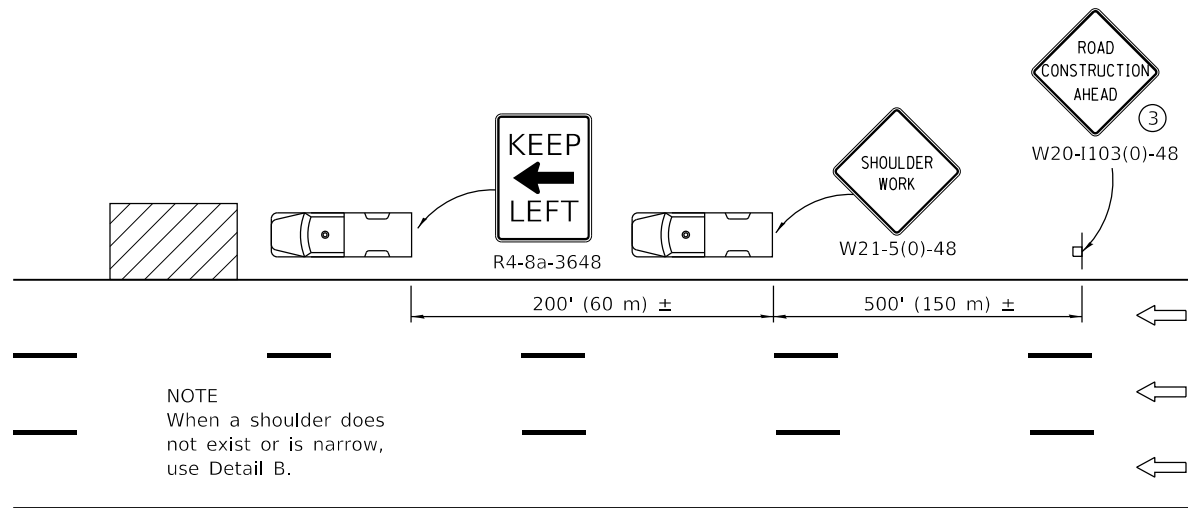

NOTE
When a shoulder does not exist or is narrow, use Detail B.

DETAIL A

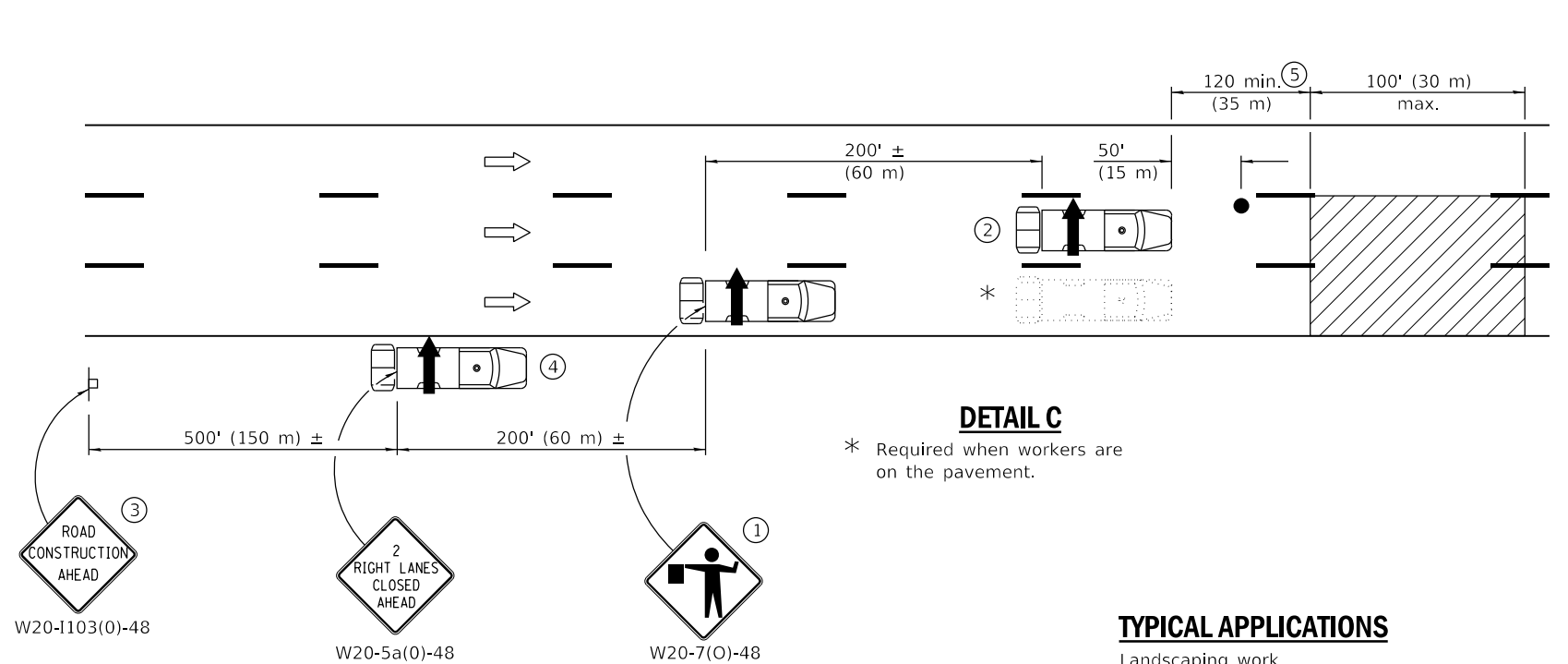

DETAIL C
* Required when workers are on the pavement.

TYPICAL APPLICATIONS

- Landscaping work
- Utility work
- Pavement marking
- Weed spraying
- Roadometer measurements
- Debris cleanup
- Crack pouring

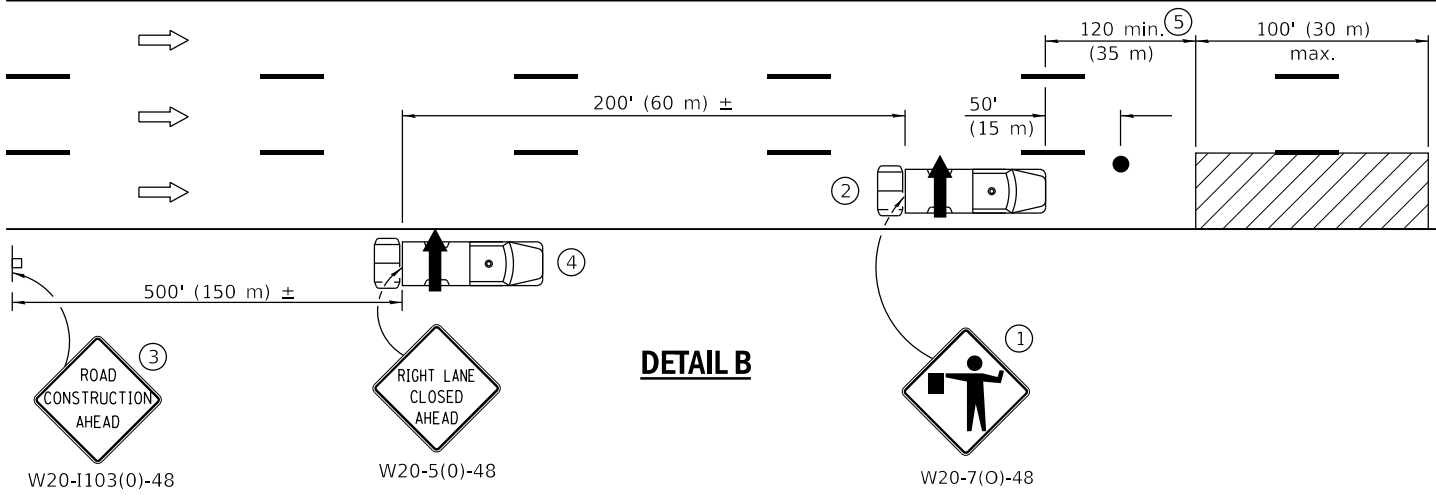

DETAIL B

- ① Flaggers are required when workers are on the pavement.
- ② For striping operations only. See sign arrow detail on this standard.
- ③ For stationary operations which are on the roadway or shoulder, greater than 15 minutes and up to 1 hour.
- ④ Omit truck, attenuator and arrow board when no shoulder exists due to curb and gutter.
- ⑤ The distance between the work and the lead truck may vary according to terrain or paint/crack sealing time.



G20-1101-2430
(appropriate arrow)
② (when striping only)

GENERAL NOTES

This Standard is used where any vehicle, equipment, workers or their activities will require:
1) stationary operations up to 1 hour, or 2) a continuous or intermittent moving operation where the average speed of movement is greater than 1 mph (2 km/h).

This Standard is also applicable when work is being performed in the left lane(s) or on the median shoulder. Under these conditions, KEEP RIGHT signs shall be substituted for KEEP LEFT signs and arrow board indications shall be directed to the right.

All dimensions are in inches (millimeter) unless otherwise shown.

SYMBOLS

- Arrow board
- Work area
- Truck with flashing amber light
- Truck/Trailer mounted attenuator
- Flagger with traffic control sign
- Sign

DATE	REVISIONS
1-1-17	Revised 'NOTE' on DETAIL A to use DETAIL B in lieu of DETAIL C.
4-1-16	Rev. gen. notes. Added note ⑤. Rev. dist. between work and lead truck.

LANE CLOSURE, MULTILANE, INTERMITTENT OR MOVING OPER., FOR SPEEDS ≤ 40 MPH

STANDARD 701427-05

Illinois Department of Transportation

PASSED January 1, 2017
Paul L. ...
ENGINEER OF SAFETY PROG. AND ENGINEERING

ISSUED 1-1-17

APPROVED January 1, 2017
Maureen M. ...
ENGINEER OF DESIGN AND ENVIRONMENT

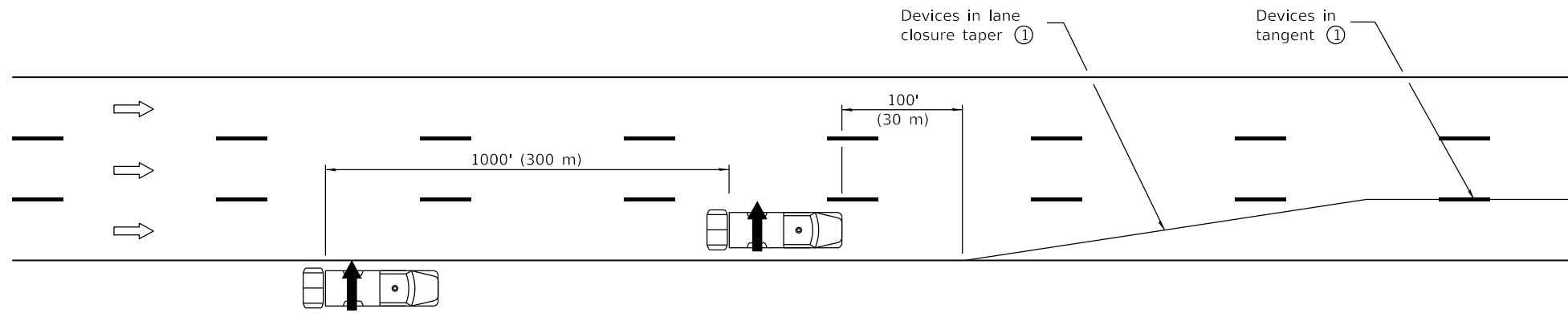

① See plans or appropriate Standard for delineating devices, spacing and length of taper/tangent.

CASE I

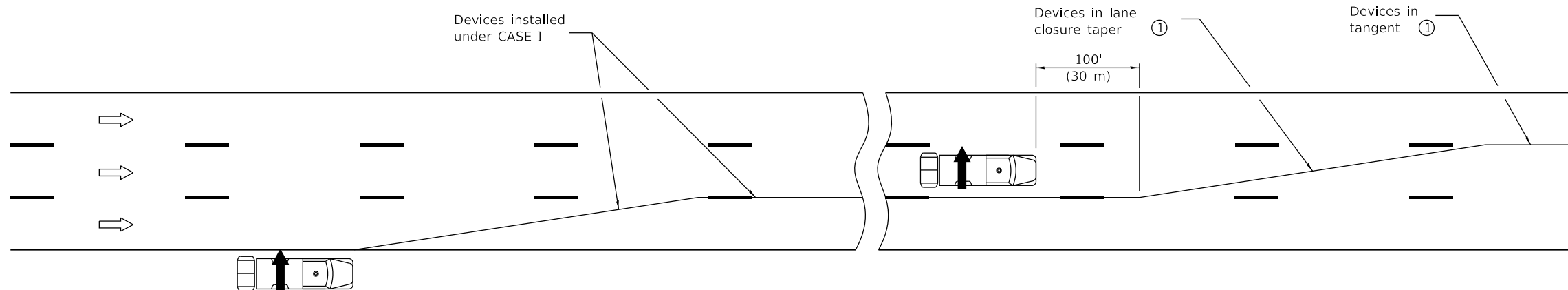

CASE I depicts the setup of delineating devices for a single outside lane closure.



CASE II

CASE II depicts the setup of delineating devices for a two lane closure. The single lane closure device setup as depicted in CASE I shall be performed prior to the setup for the second lane closure.

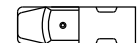
SYMBOLS

-  Arrow board
-  Truck with flashing amber light
-  Truck/Trailer mounted attenuator

GENERAL NOTES

This Standard is used for setup and removal of lane closures on freeways/expressways having ADT greater than 25,000.

Trucks with arrow boards and truck-mounted-attenuators shall be in place as shown for the setup and removal of the lane closure taper(s) and the first 100' (30 m) of channelizing devices in the tangent(s).

This Standard is also applicable when work is being performed in the left lane(s) or on the median shoulder. Under these conditions arrow board indications shall be directed to the right.

All dimensions are in inches (millimeter) unless otherwise shown.

DATE	REVISIONS
4-1-16	Added trailer option for attenuator symbol.
1-1-14	New Standard.

**TRAFFIC CONTROL
SETUP AND REMOVAL
FREEWAY/EXPRESSWAY**

STANDARD 701428-01

Illinois Department of Transportation

PASSED April 1, 2016

[Signature]
ENGINEER OF SAFETY ENGINEERING

APPROVED April 1, 2016

[Signature]
ENGINEER OF DESIGN AND ENVIRONMENT

ISSUED 1-1-97

WORK ZONE
W21-III5(0)-3618
SPEED LIMIT
R2-1-3648
45
PHOTO ENFORCED
R10-1108p-3618
SXXX FINE MINIMUM
R2-1106p-3618

END WORK ZONE SPEED LIMIT
G20-1103-6036

NEXT X MILES
W7-3a-2418

W6-3(0)-48

W20-5L(0)-48

ROAD WORK 1 MILE
W20-1(0)-48
Or
ROAD CONSTRUCTION 1 MILE
W20-1103(0)-48

W4-2L(0)-48

W20-1103(0)-48

White reflectorized pavement marking tape

Yellow reflectorized pavement marking tape

See DETAIL A

Devices at 50' (15 m) cts.

Drums at 100' (30 m) cts.

Barricades at 50' (15 m) centers

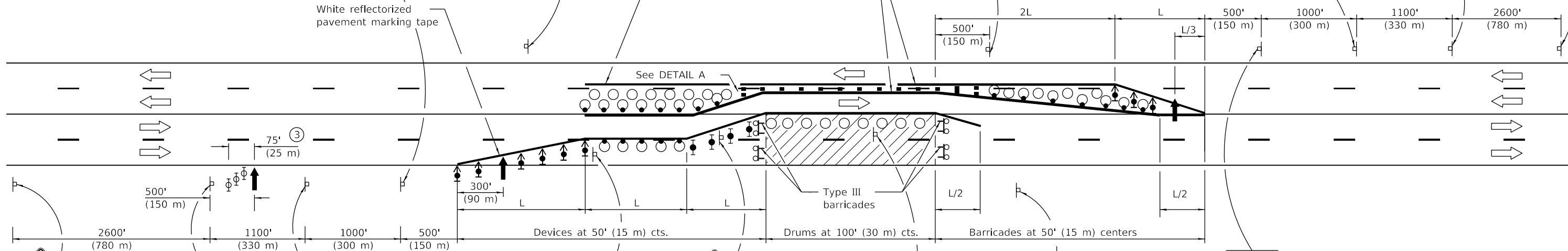

ROAD CONSTRUCTION 1 MILE
For contract construction projects
W20-1103(0)-48
Or
ROAD WORK 1 MILE
For maintenance and utility projects
W20-1(0)-48

RIGHT LANE CLOSED 1/2 MILE
W20-5(0)-48

W4-2R(0)-48

W1-4L(0)-48

W6-3(0)-48

END WORK ZONE SPEED LIMIT
G20-1103-6036

WORK ZONE
W21-III5(0)-3618
SPEED LIMIT
R2-1-3648
PHOTO ENFORCED
R10-1108p-3618
SXXX FINE MINIMUM
R2-1106p-3618

L = lane width X taper ratio	
Normal Posted Speed	Taper Ratio
mph 55	55/1
45	45/1

SYMBOLS

- Arrow board
- Work area
- Sign
- Drum with steady burn monodirectional light
- Direction indicator barricade with steady burn monodirectional light
- Type II barricade with steady burn monodirectional light
- Type II barricade, drum or vertical barricade with monodirectional flashing light
- Tubular marker
- Type III barricade with flashing monodirectional lights
- Drum

- ① Shall be repeated every 1 mile (1.6 km).
- ② Shall be repeated every 1 mile (1.6 km) in each direction in the tangent section unless concrete barrier is used.
- ③ Three Type II barricades, drums or vertical barricades at 25' (8 m) centers.

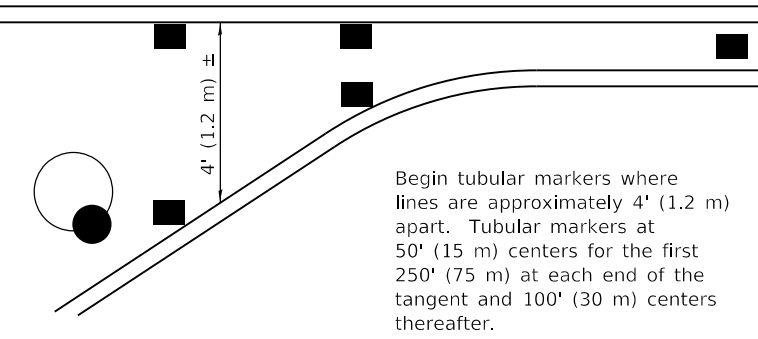

DETAIL A

GENERAL NOTES

This Standard is used where at any time, any vehicle, equipment, workers or their activities require the closure of two adjacent lanes and a temporary crossover is provided by making use of one lane of pavement normally used by opposing flow of traffic and flexible delineators are used to separate the opposing traffic.

Cones may be substituted for flexible delineators during daytime operations at half the spacing.

All dimensions are in inches (millimeters) unless otherwise shown.

Illinois Department of Transportation

PASSED January 1, 2018
Paul LaRocca
ENGINEER OF SAFETY PROG. AND ENGINEERING

APPROVED January 1, 2018
Matthew M. Adams
ENGINEER OF DESIGN AND ENVIRONMENT

ISSUED 1-1-97

DATE	REVISIONS
1-1-18	Omitted lights on drums in tangent for westbound traffic and at work area.
1-1-17	Replaced W18-1100 plaque with W7-3a plaque. Changed flexible delineator to tubular marker.





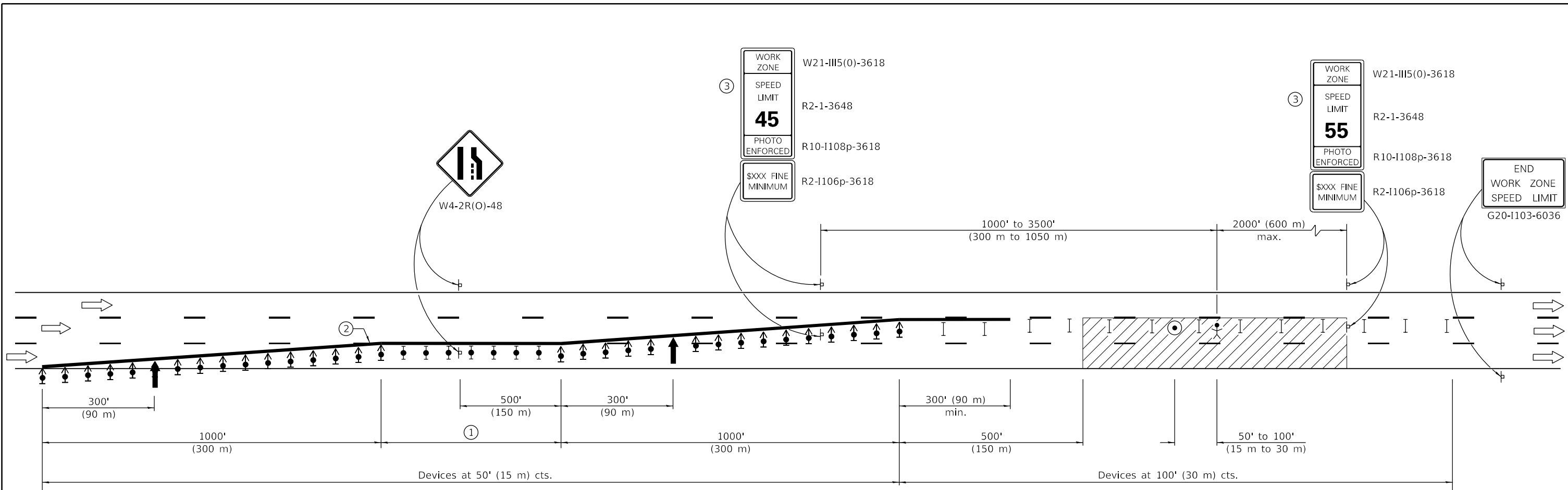



LANE CLOSURE, MULTILANE, UNDIV. WITH CROSSOVER, FOR SPEEDS ≥ 45 MPH TO 55 MPH

STANDARD 701431-13



See Standard 701400 for approach
Start of lane closure taper

SYMBOLS

-  Arrow board
-  Work area
-  Worker
-  Sign
-  Direction indicator barricade with steady burn monodirectional light
-  Type II barricade, drum, or vertical barricade with steady burn monodirectional light
-  Spotter
-  Type II barricade, drum, or vertical barricade

① The length of the tangent section shall be:

Duration of Closure	Length of Tangent Section
< 14 Days	1000' (300 m)
≥ 14 Days	2000' (600 m)

② ReflectORIZED temporary pavement marking tape shall be placed throughout the tapers and for 300' (90 m) along-side the work area when the closure time is greater than fourteen days. The edge line shall be white for right lane closures and yellow for left lane closures.

③ Work zone speed limits signs shall be moved as necessary to maintain the required spacing between the signs and the workers in each separate work activity. Work Zone Speed Limit 55 Photo Enforced sign shall be omitted when the work area dictates that placement of the sign array within 500' (150 m) of the End Work Zone Speed Limit sign.

GENERAL NOTES

This Standard is used where at any time any vehicle, equipment, workers or their activities will encroach on two lanes of a freeway/expressway.

This Standard must always be used in combination with Standard 701400.

This Standard also applies when work is being performed in the left lanes. Under these conditions, the set up would be a mirror image to what is shown.

Check barricades shall be placed in the middle of the closed lanes at 1000' (300 m) centers.

All dimensions are in inches (millimeters) unless otherwise shown.

DATE	REVISIONS
1-1-21	Corrected symbol for type II barricade with steady burn monodirectional light and altered device spacing callout.
1-1-20	Replaced flagger with spotter.

**TWO LANE CLOSURE,
FREEWAY/EXPRESSWAY**

STANDARD 701446-11

Illinois Department of Transportation

PASSED January 1, 2021
Cynthia A. [Signature]
ENGINEER OF SAFETY PROG. AND ENGINEERING

APPROVED January 1, 2021
[Signature]
ENGINEER OF DESIGN AND ENVIRONMENT

ISSUED 1-1-05

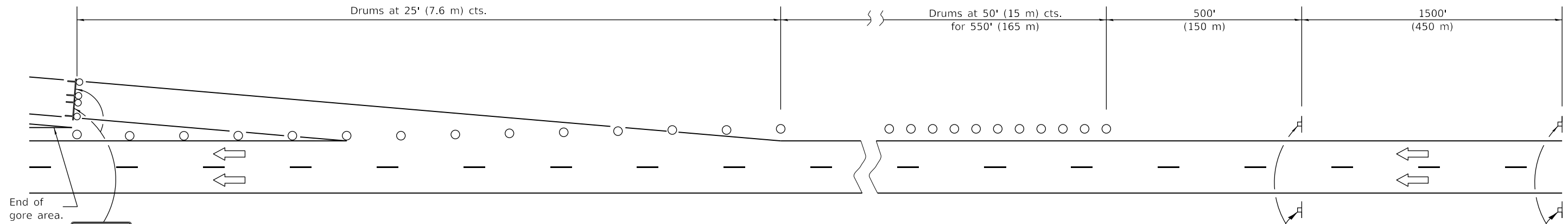

EXIT RAMP CLOSURE

- ① Omit this sign when median is less than 10' (3 m).
- ② See sign spacing table.
- ③ Drums for entrance ramp closure shall be omitted if turn lanes are not present.

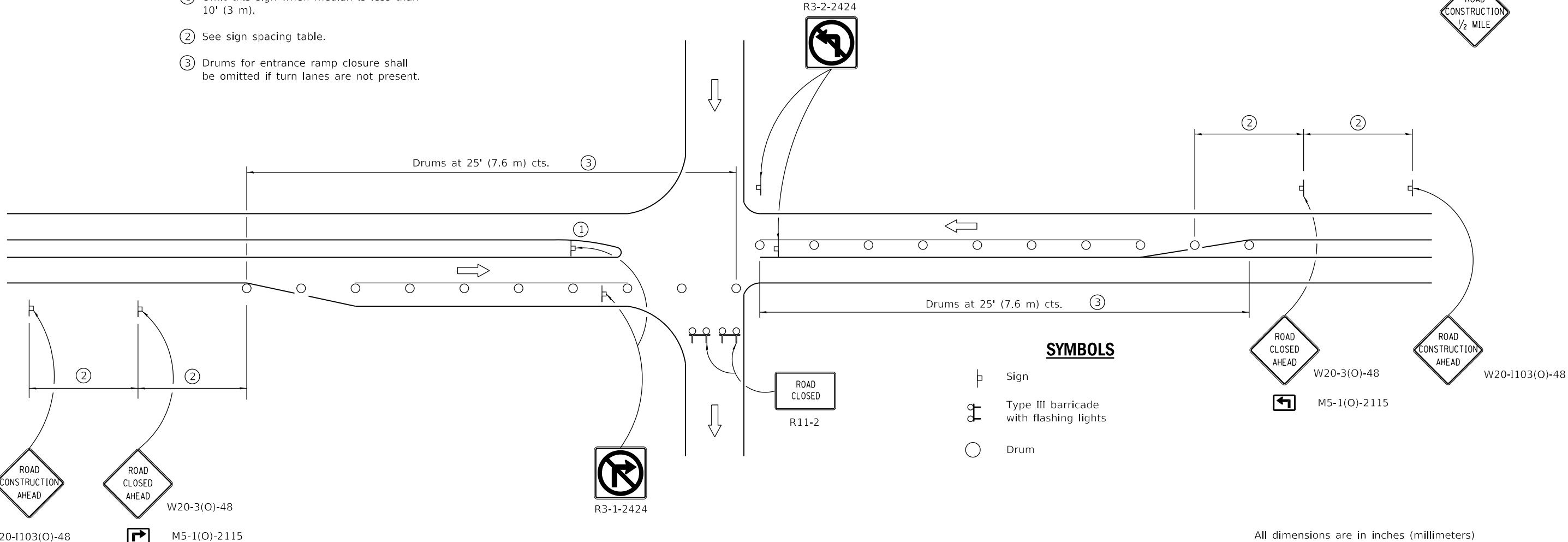

ENTRANCE RAMP CLOSURE

SYMBOLS

- ▮ Sign
- ⚡ Type III barricade with flashing lights
- Drum
- ⬇️ W20-3(O)-48
- ⬆️ M5-1(O)-2115
- ⚠️ W20-1103(O)-48

SIGN SPACING	
Posted Speed	Sign Spacing
55	500' (150 m)
50-45	350' (100 m)
<45	200' (60 m)

All dimensions are in inches (millimeters) unless otherwise shown.

Illinois Department of Transportation
 PASSED January 1, 2018
Paul L. ...
 ENGINEER OF SAFETY PROG. AND ENGINEERING
 APPROVED January 1, 2018
Walter M. ...
 ENGINEER OF DESIGN AND ENVIRONMENT

ISSUED 1-1-09

DATE	REVISIONS
1-1-18	Omitted lights from drums.
1-1-17	Added flashing lights to Type III barricade.



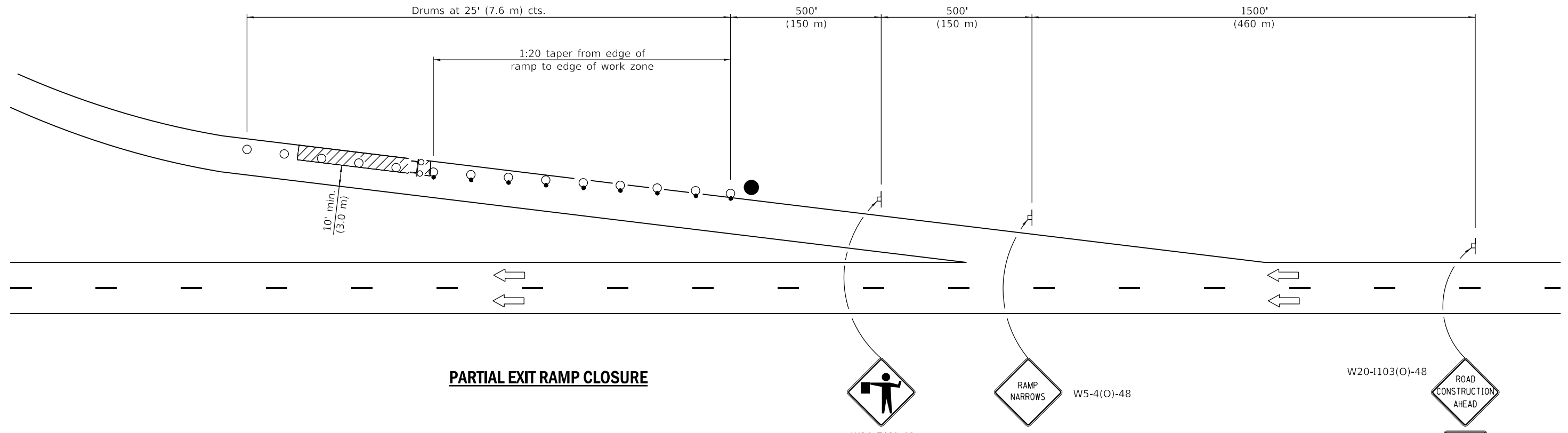



RAMP CLOSURE
FREEWAY/EXPRESSWAY
STANDARD 701451-05



PARTIAL EXIT RAMP CLOSURE



SYMBOLS

-  Sign
-  Type III barricade with flashing lights
-  Drum with steady burning light
-  Work area
-  Flagger with traffic control sign
-  Drum

All dimensions are in inches (millimeters) unless otherwise shown.

Illinois Department of Transportation

PASSED January 1, 2018
Paul L. ...
 ENGINEER OF SAFETY PROG. AND ENGINEERING

APPROVED January 1, 2018
Maureen M. ...
 ENGINEER OF DESIGN AND ENVIRONMENT

ISSUED 1-1-09

DATE	REVISIONS
1-1-18	Omitted lights on drums in tangent.
1-1-17	Added flashing lights to Type III barricade.

**PARTIAL EXIT RAMP CLOSURE
 FREEWAY/EXPRESSWAY**

STANDARD 701456-05

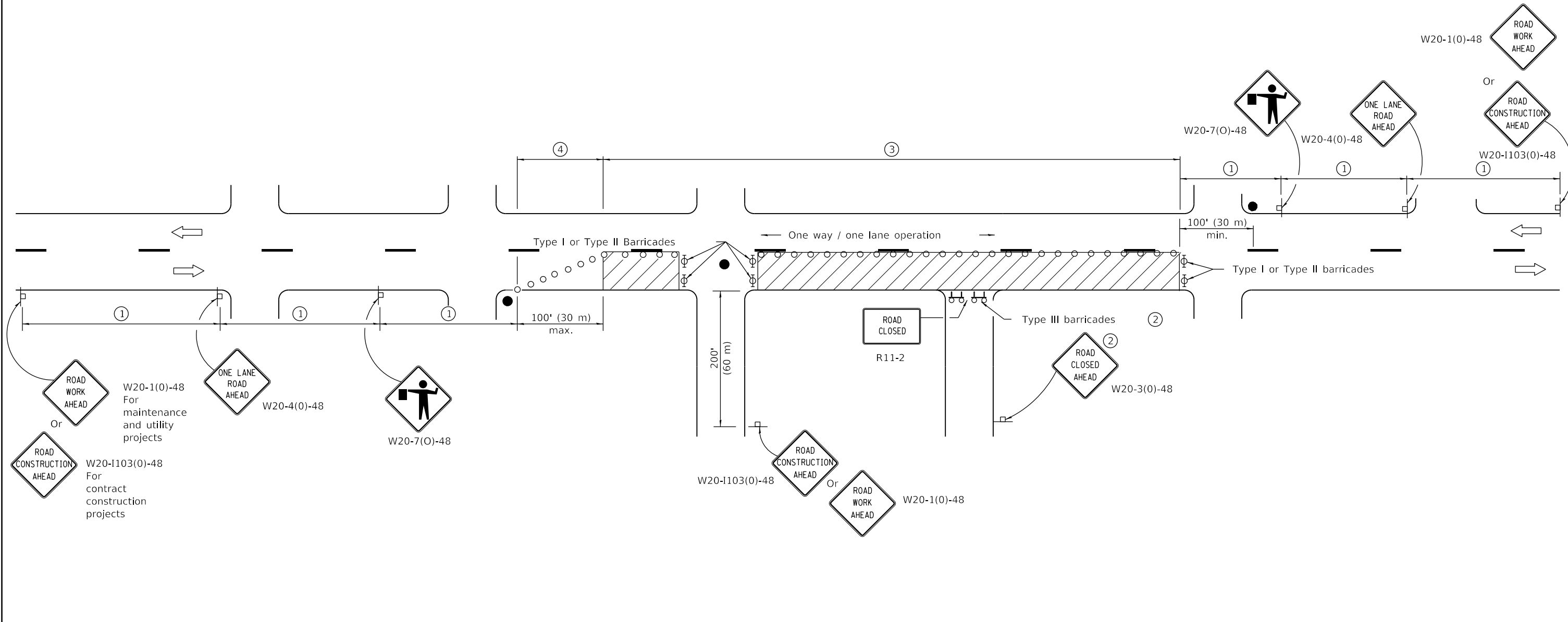

ROAD WORK AHEAD W20-1(0)-48
 Or ROAD CONSTRUCTION AHEAD W20-1103(0)-48
 For maintenance and utility projects
 For contract construction projects

ONE LANE ROAD AHEAD W20-4(0)-48
 W20-7(O)-48

ROAD CLOSED R11-2
 ROAD CONSTRUCTION AHEAD W20-1103(0)-48
 Or ROAD WORK AHEAD W20-1(0)-48

ROAD CLOSED AHEAD W20-3(0)-48

SIGN SPACING	
Posted Speed	Sign Spacing
55	500' (150 m)
50-45	350' (100 m)
<45	200' (60 m)

SYMBOLS

- Work area
- Cone, drum or barricade (not required for moving operations)
- Sign on portable or permanent support
- Flagger with traffic control sign
- Barricade or drum with flashing light
- Type III barricade with flashing lights

- ① Refer to SIGN SPACING TABLE for distances.
- ② For approved sideroad closures.
- ③ Cones at 25' (8 m) centers for 250' (75 m). Additional cones may be placed at 50' (15 m) centers. When drums or Type I or Type II barricades are used, the interval between devices may be doubled.
- ④ Cones, drums or barricades at 20' (6 m) centers.

GENERAL NOTES

This Standard is used where at any time, day or night, any vehicle, equipment, workers or their activities encroach on the pavement requiring the closure of one traffic lane in an urban area.

All dimensions are in inches (millimeters) unless otherwise shown.

DATE	REVISIONS
1-1-11	Revised flagger sign.
1-1-09	Switched units to English (metric).
	Corrected sign No.'s.

**URBAN LANE CLOSURE,
2L, 2W, UNDIVIDED**

STANDARD 701501-06

Illinois Department of Transportation
 PASSED January 1, 2011
 ENGINEER OF SAFETY ENGINEERING
 APPROVED January 1, 2011
 ENGINEER OF DESIGN AND ENVIRONMENT

ISSUED 1-1-97

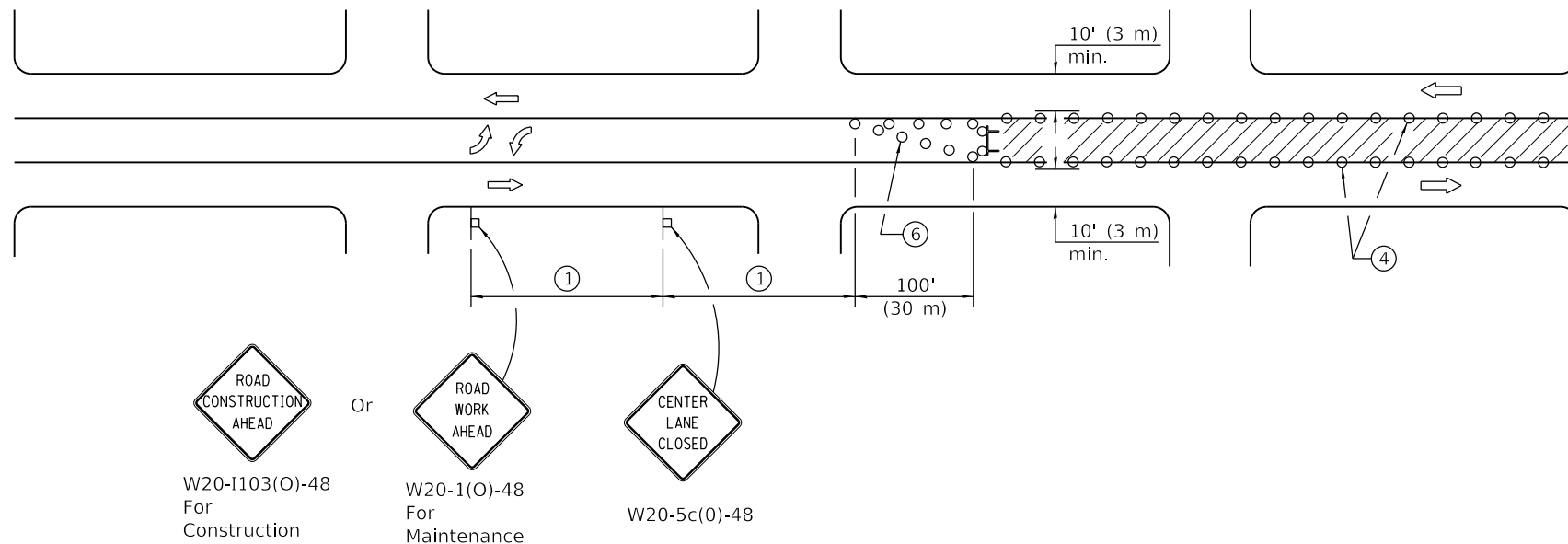

W20-1103(O)-48
For
Construction

Or

W20-1(O)-48
For
Maintenance

W20-5c(O)-48

CASE I

(Signs required for both directions)

SIGN SPACING	
Posted Speed	Sign Spacing
55	500' (150 m)
50-45	350' (100 m)
<45	200' (60 m)

SYMBOLS

- Work area
- Barricade or drum with flashing light
- Flagger with traffic control sign
- Cone, drum or barricade
- Sign on portable or permanent support
- Type III barricade with flashing lights

- ① Refer to SIGN SPACING TABLE for distances.
- ② Required for speeds > 40 mph (70 km/h).
- ③ Required if work exceeds 500' (164 m) or 1 block.
- ④ Cones at 25' (8 m) centers for 250' (75 m) on approach. Additional cones may be placed at 50' (15 m) centers. When drums or type I or II barricades are used, the interval between devices may be doubled.
- ⑤ For approved sideroad closures.
- ⑥ Cones, drums or barricades at 20' (6 m) centers in taper.
- ⑦ Use flagger sign only when flagger is present.

GENERAL NOTES

This Standard is used to close one lane of an urban, two lane, two way roadway with a bidirectional turn lane.

Case I applies when no workers are present. When workers are present, two lanes shall be closed and traffic control shall be according to Standard 701501.

Calculate L as follows:

SPEED LIMIT	FORMULAS	
	English	(Metric)
40 mph (70 km/h) or less:	$L = \frac{WS^2}{60}$	$L = \frac{WS^2}{150}$
45 mph (80 km/h) or greater:	$L = (W)(S)$	$L = 0.65(W)(S)$

W = Width of offset in feet (meters).
S = Normal posted speed mph (km/h).

All dimensions are in inches (millimeters) unless otherwise shown.

Illinois Department of Transportation

APPROVED January 1, 2019
Lyndee Watt
ENGINEER OF SAFETY PROG. AND ENGINEERING

APPROVED January 1, 2019
J. E. C.
ENGINEER OF DESIGN AND ENVIRONMENT

ISSUED 1-1-01

DATE	REVISIONS
1-1-19	Revised to allow cones at night.
1-1-18	Corrected sign number for TWO WAY TRAFFIC sign for CASE II.

**URBAN LANE CLOSURE,
2L, 2W, WITH BIDIRECTIONAL
LEFT TURN LANE**
(Sheet 1 of 2)

STANDARD 701502-09

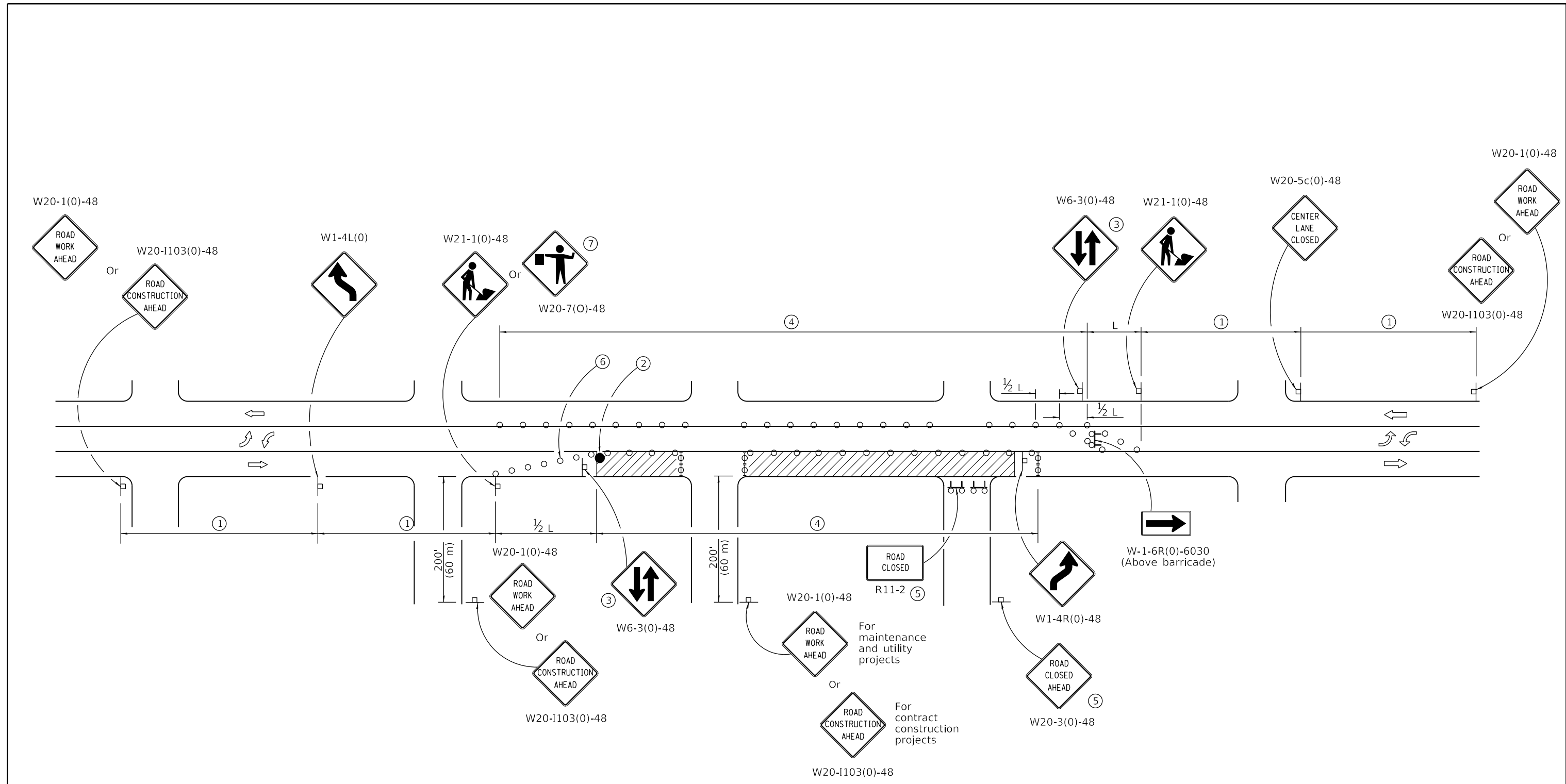

CASE II

Illinois Department of Transportation

APPROVED January 1, 2019
Cynthia Watt
 ENGINEER OF SAFETY PROG. AND ENGINEERING

APPROVED January 1, 2019
J. Ed. El
 ENGINEER OF DESIGN AND ENVIRONMENT

ISSUED 1-1-01

**URBAN LANE CLOSURE,
 2L, 2W, WITH BIDIRECTIONAL
 LEFT TURN LANE**

(Sheet 2 of 2)

STANDARD 701502-09

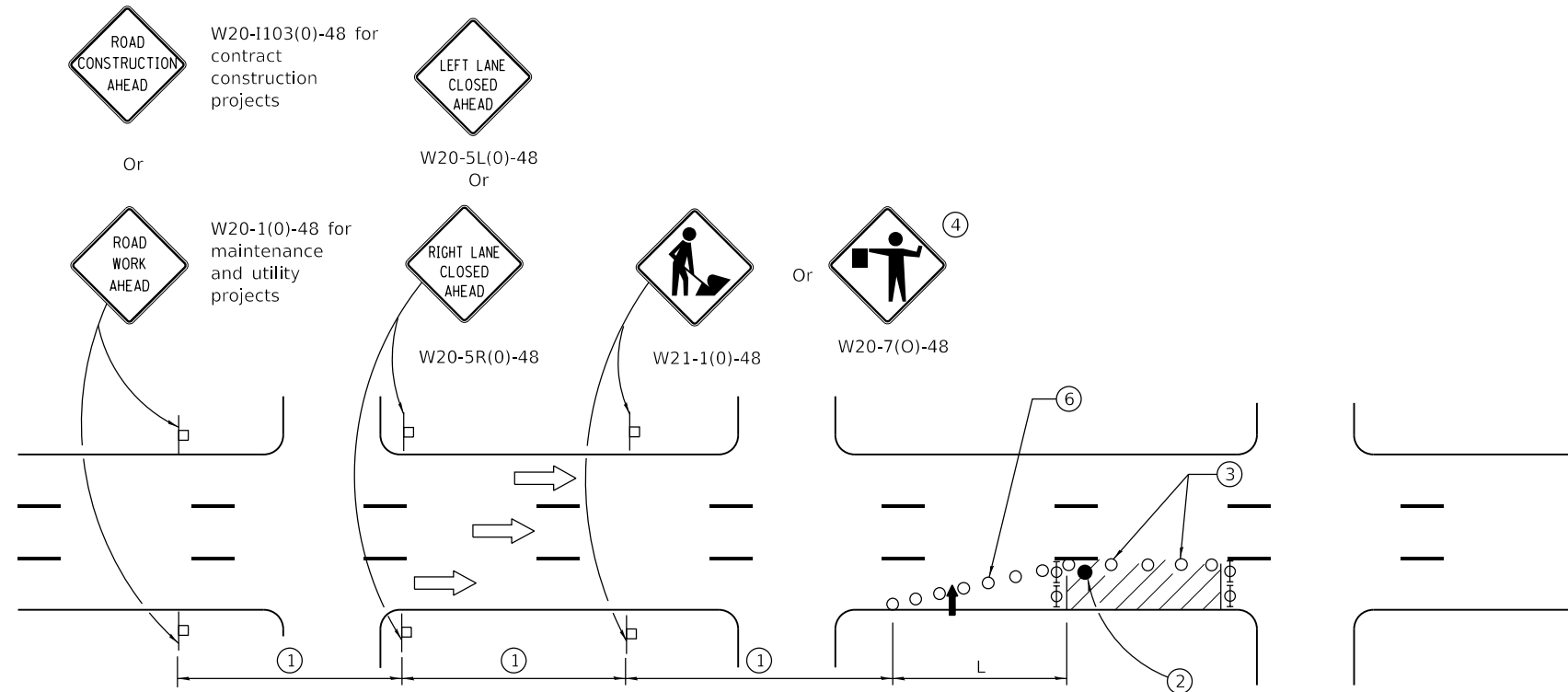

SIGN SPACING	
Posted Speed	Sign Spacing
55	500' (150 m)
50-45	350' (100 m)
<45	200' (60 m)

SYMBOLS

- Arrow board
- Cone, drum or barricade
- Sign on portable or permanent support
- Work area
- Barricade or drum with flashing light
- Type III barricade with flashing lights
- Flagger with traffic control sign.

- ① Refer to SIGN SPACING TABLE for distances.
- ② Required for speeds > 40 MPH
- ③ Cones at 25' (8 m) centers for 250' (75 m). Additional cones may be placed at 50' (15 m) centers. When drums or Type I or Type II barricades are used, the interval between devices may be doubled.
- ④ Use flagger sign only when flagger is present.
- ⑤ For approved sideroad closures.
- ⑥ Cones, drums or barricades at 20' (6 m) in taper.

GENERAL NOTES

This Standard is used where at any time, day or night, any vehicle, equipment, workers or their activities encroach on the pavement during shoulder operations or where construction requires lane closures in urban areas.

Calculate L as follows:

SPEED LIMIT	FORMULAS	
	English	(Metric)
40 mph (70 km/h) or less:	$L = \frac{WS^2}{60}$	$L = \frac{WS^2}{150}$
45 mph (80 km/h) or greater:	$L = (W)(S)$	$L = 0.65(W)(S)$

W = Width of offset in feet (meters).
S = Normal posted speed mph (km/h).

All dimensions are in inches (millimeters) unless otherwise shown.

Illinois Department of Transportation

PASSED January 1, 2014

 ENGINEER OF SAFETY ENGINEERING

APPROVED January 1, 2014

 ENGINEER OF DESIGN AND ENVIRONMENT



ISSUED 1-1-97

DATE	REVISIONS
1-1-14	Revised workers sign number to agree with current MUTCD.
1-1-13	Omitted text 'WORKERS' sign.

**URBAN LANE CLOSURE,
MULTILANE, 1W OR 2W WITH
NONTRAVERSABLE MEDIAN**
 (Sheet 1 of 2)

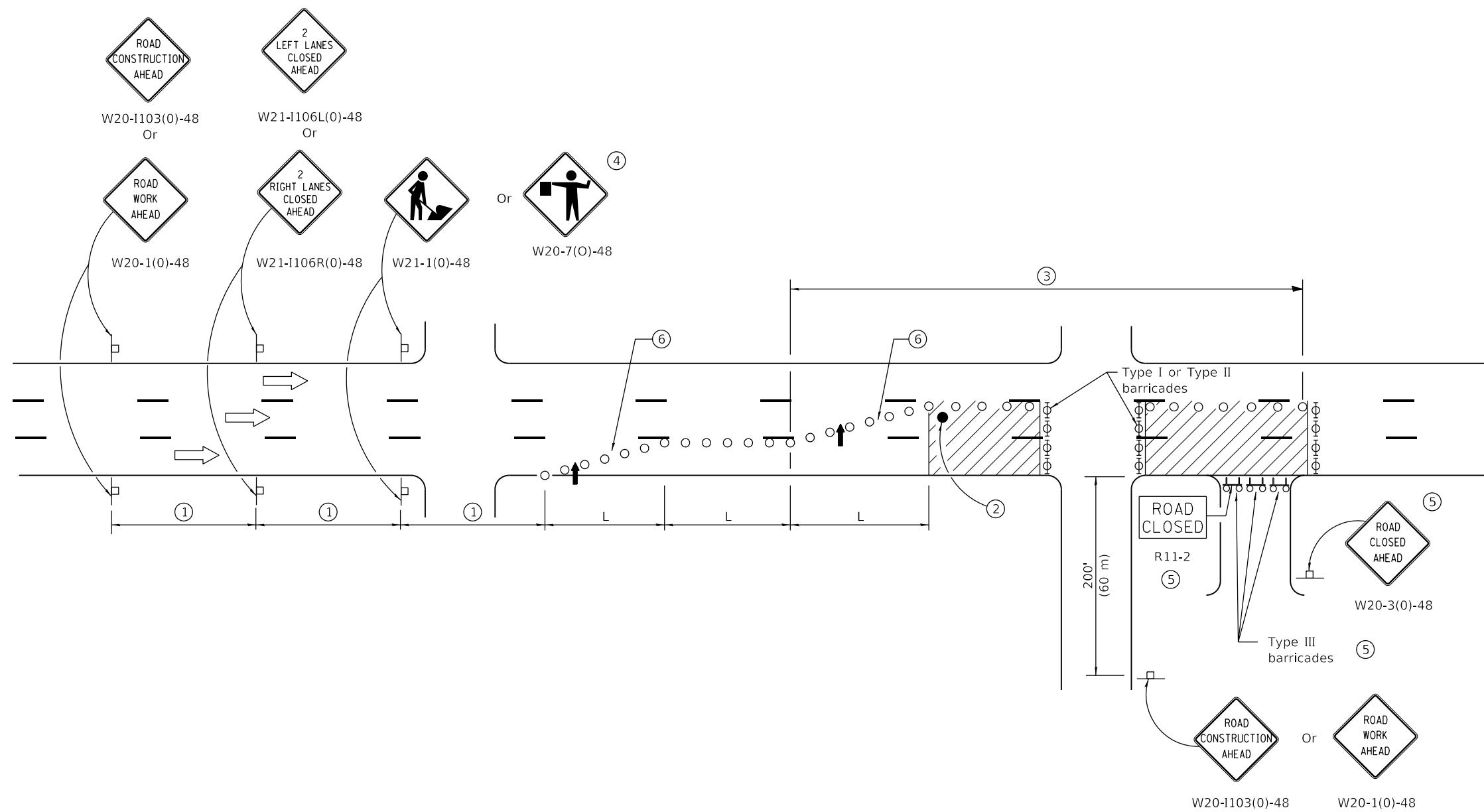
STANDARD 701601-09

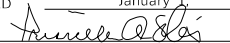

 Illinois Department of Transportation
 PASSED January 1, 2014

 ENGINEER OF SAFETY ENGINEERING
 APPROVED January 1, 2014

 ENGINEER OF DESIGN AND ENVIRONMENT

ISSUED 1-1-97

**URBAN LANE CLOSURE,
 MULTILANE, 1W OR 2W WITH
 NONTRAVERSABLE MEDIAN**

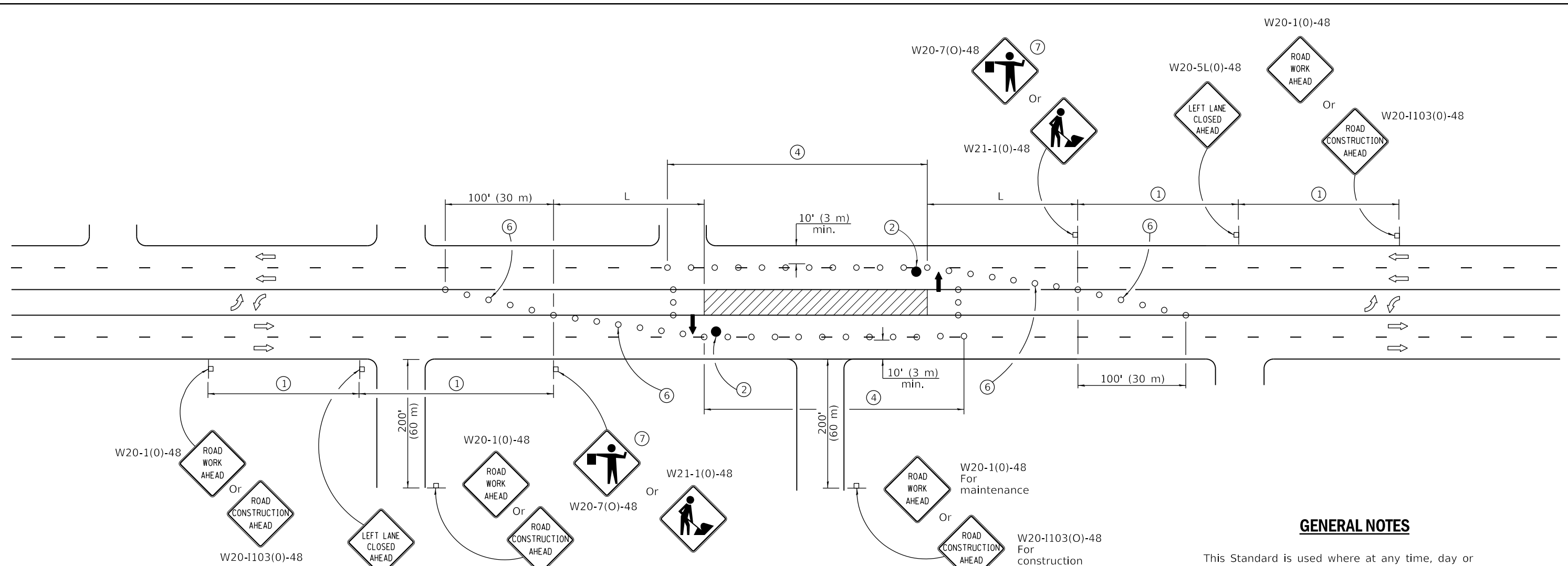
(Sheet 2 of 2)

STANDARD 701601-09



SIGN SPACING	
Posted Speed	Sign Spacing
55	500' (150 m)
50-45	350' (100 m)
<45	200' (60 m)

- SYMBOLS**
- Arrow board
 - Work area
 - Barricade or drum with steady burning mondirectional light
 - Flagger with traffic control sign
 - Cone, drum or barricade
 - Sign on portable or permanent support
 - Type III barricade with flashing lights

CASE I

- ① Refer to SIGN SPACING TABLE for distances.
- ② Required for speeds > 40 mph (70 km/h).
- ③ Required if work exceeds 500' (164 m) or 1 block, repeat every 1 mile (1.6 km).
- ④ Cones at 25' (8 m) centers for 250' (75 m) on approach. Additional cones may be placed at 50' (15 m) centers. When drums or type I or II barricades are used, the interval between devices may be doubled.
- ⑤ For approved sideroad closures.
- ⑥ Cones, drums or barricades at 20' (6 m) centers in taper.
- ⑦ Use flagger sign only when flagger is present.

GENERAL NOTES

This Standard is used where at any time, day or night, any vehicle, equipment, workers or their activities encroach on the pavement requiring the closure of one traffic lane in an Urban area.

If the work operation is performed between 9:00 a.m. and 3:00 p.m. and does not exceed 15 min. Traffic protection shall be as shown for Standard 701426.

Calculate L as follows:

SPEED LIMIT	FORMULAS	
	English	(Metric)
40 mph (70 km/h) or less:	$L = \frac{WS^2}{60}$	$L = \frac{WS^2}{150}$
45 mph (80 km/h) or greater:	$L=(W)(S)$	$L=0.65(W)(S)$

W = Width of offset in feet (meters).

S = Normal posted speed mph (km/h).

All dimensions are in inches (millimeters) unless otherwise shown.

DATE	REVISIONS
1-1-19	Revised to allow cones at night.
1-1-18	Moved arrow boards into closed lanes for CASE I.

**URBAN LANE CLOSURE,
MULTILANE, 2W WITH
BIDIRECTIONAL LEFT TURN LANE**

(Sheet 1 of 4)

STANDARD 701602-10

Illinois Department of Transportation

APPROVED January 1, 2019
Cynthia Watt
ENGINEER OF SAFETY PROG. AND ENGINEERING

APPROVED January 1, 2019
Joe E. ...
ENGINEER OF DESIGN AND ENVIRONMENT

ISSUED 1-1-13

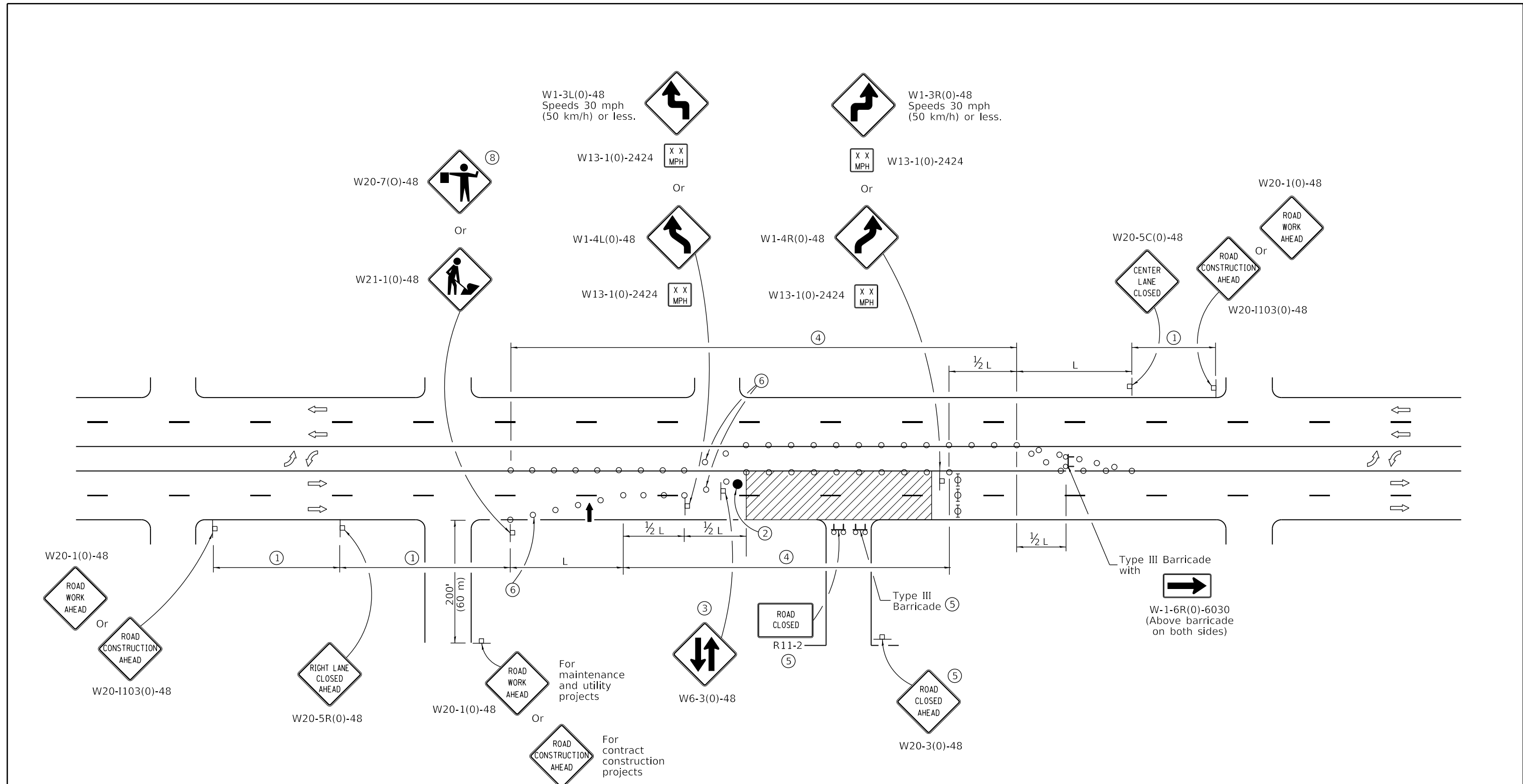

CASE II

Illinois Department of Transportation
 APPROVED January 1, 2019
Cynthia Watt
 ENGINEER OF SAFETY PROG. AND ENGINEERING
 APPROVED January 1, 2019
J. Ed. Ellis
 ENGINEER OF DESIGN AND ENVIRONMENT
 ISSUED 1-1-13

**URBAN LANE CLOSURE,
 MULTILANE, 2W WITH
 BIDIRECTIONAL LEFT TURN LANE**
 (Sheet 2 of 4)
STANDARD 701602-10

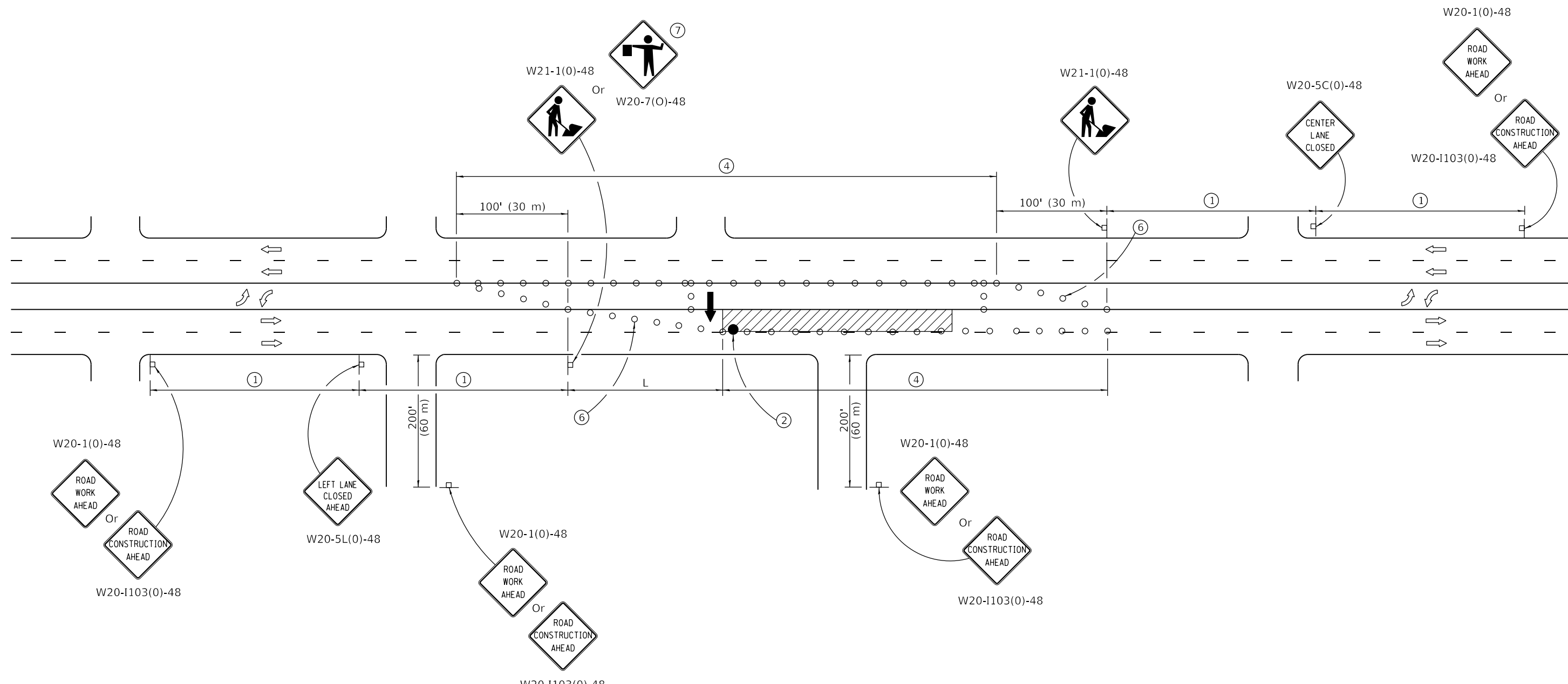

CASE III

Illinois Department of Transportation

APPROVED January 1, 2019
Cynthia Watt
 ENGINEER OF SAFETY PROG. AND ENGINEERING

APPROVED January 1, 2019
J. E. ...
 ENGINEER OF DESIGN AND ENVIRONMENT

ISSUED 1-1-13

**URBAN LANE CLOSURE,
 MULTILANE, 2W WITH
 BIDIRECTIONAL LEFT TURN LANE**

(Sheet 3 of 4)

STANDARD 701602-10

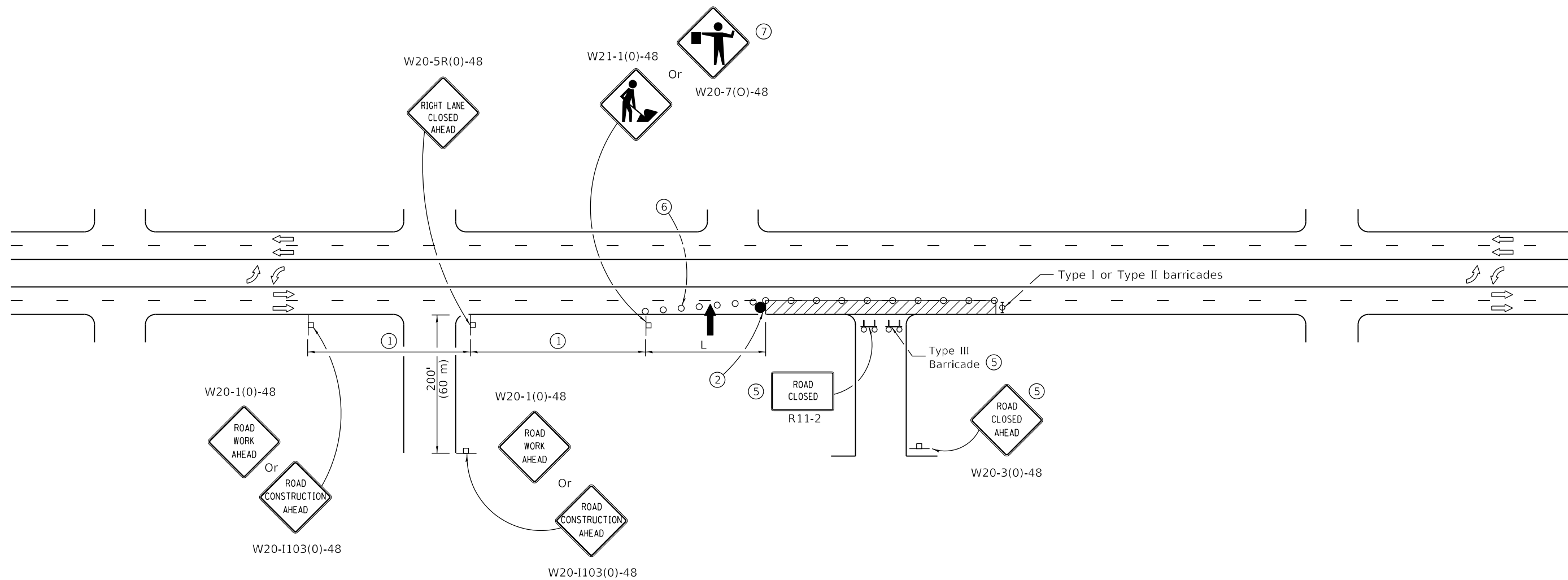

CASE IV

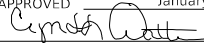
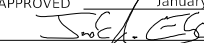

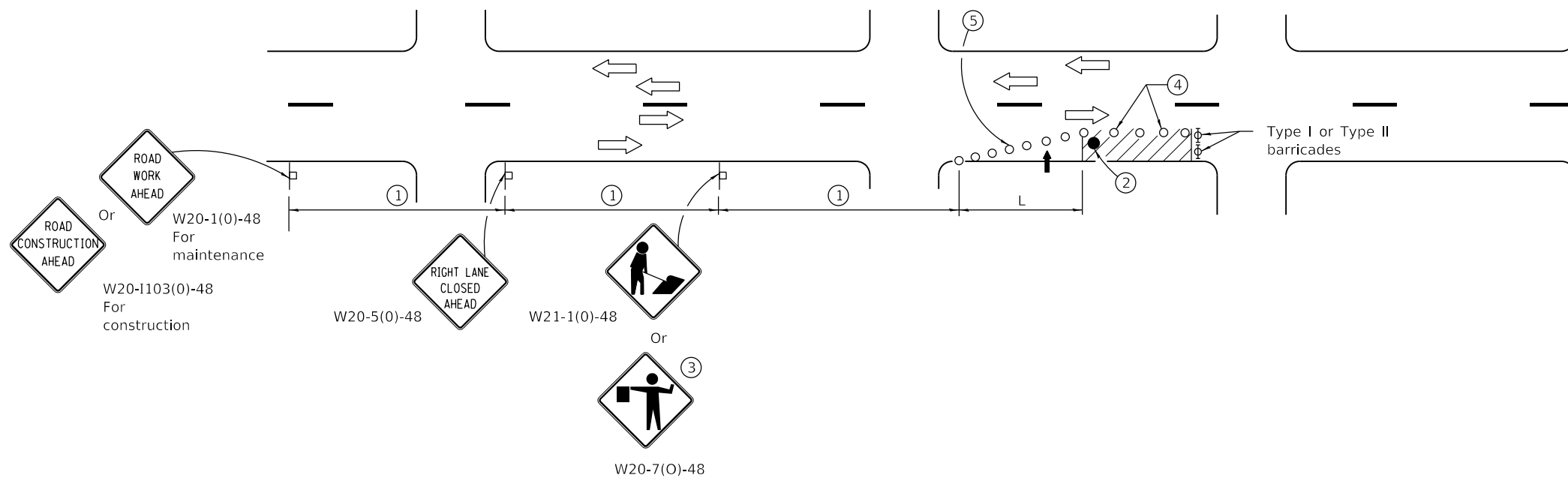

 Illinois Department of Transportation
 APPROVED January 1, 2019

 ENGINEER OF SAFETY PROG. AND ENGINEERING
 APPROVED January 1, 2019

 ENGINEER OF DESIGN AND ENVIRONMENT

ISSUED 1-1-13

**URBAN LANE CLOSURE,
 MULTILANE, 2W WITH
 BIDIRECTIONAL LEFT TURN LANE**
 (Sheet 4 of 4)
STANDARD 701602-10



SIGN SPACING	
Posted Speed	Sign Spacing
55	500' (150 m)
50-45	350' (100 m)
<45	200' (60 m)

- SYMBOLS**
-  Arrow board
 -  Cone, drum or barricade
 -  Sign on portable or permanent support
 -  Work area
 -  Barricade or drum with flashing light
 -  Flagger with traffic control sign.

- ① Refer to SIGN SPACING TABLE for distances.
- ② Required for speeds > 40 mph.
- ③ Use flagger sign only when flagger is present.
- ④ Cones at 25' (8 m) centers for 250' (75 m). Additional cones may be placed at 50' (15 m) centers. When drums or Type I or Type II barricades are used, the interval between devices may be doubled.
- ⑤ Cones, drums or barricades at 20' (6 m) centers in taper.

GENERAL NOTES

This Standard is used where at any time, day or night, any vehicle, equipment, workers or their activities encroach on the pavement requiring the closure of one traffic lane in an Urban area.

Calculate L as follows:

SPEED LIMIT	FORMULAS	
	English	(Metric)
40 mph (70 km/h) or less:	$L = \frac{WS^2}{60}$	$L = \frac{WS^2}{150}$
45 mph (80 km/h) or greater:	$L = (W)(S)$	$L = 0.65(W)(S)$

W = Width of offset in feet (meters).
 S = Normal posted speed mph (km/h).

All dimensions are in inches (millimeters) unless otherwise shown.

Illinois Department of Transportation

PASSED January 1, 2015
 ENGINEER OF SAFETY ENGINEERING

APPROVED January 1, 2015
 ENGINEER OF DESIGN AND ENVIRONMENT

ISSUED 1-1-97

DATE	REVISIONS
1-1-15	Renamed standard. Moved case on Sheet 2 to new Highway Standard.
1-1-14	Revised workers sign number to agree with current MUTCD.

URBAN SINGLE LANE CLOSURE, MULTILANE, 2W WITH MOUNTABLE MEDIAN

STANDARD 701606-10

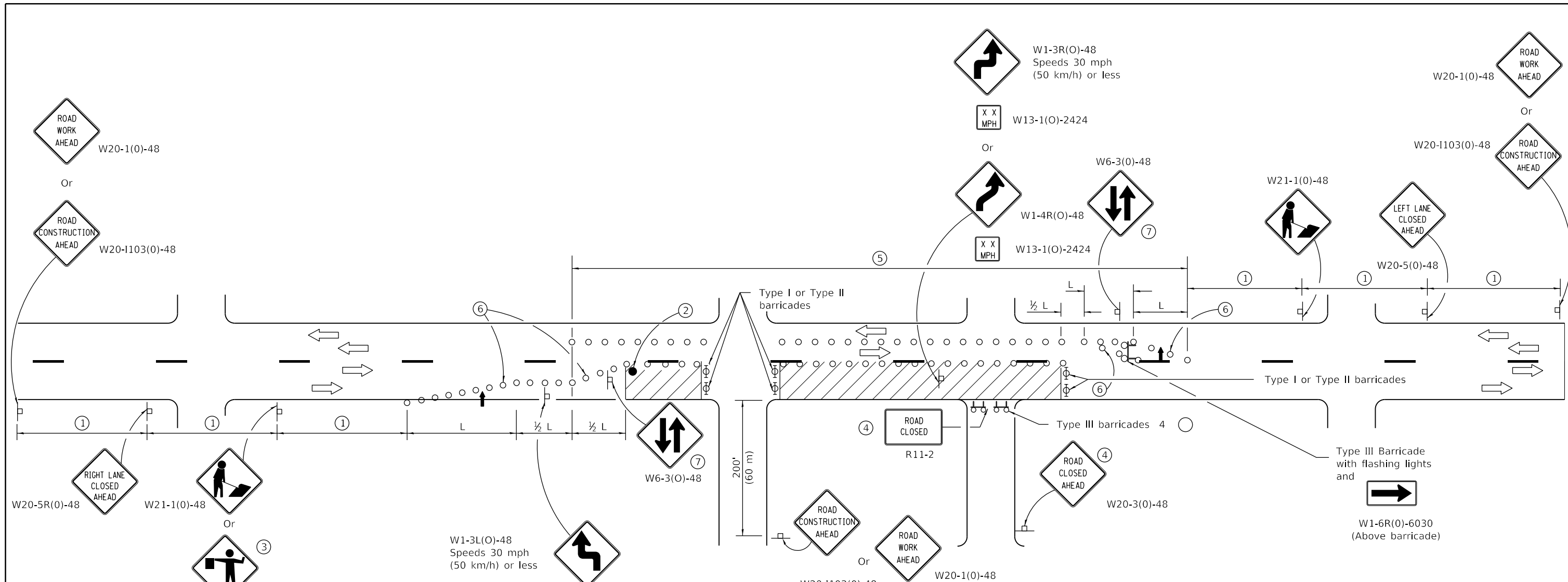

SIGN SPACING	
Posted Speed	Sign Spacing
55	500' (150 m)
50-45	350' (100 m)
<45	200' (60 m)

- W1-3L(O)-48
Speeds 30 mph
(50 km/h) or less
- W13-1(O)-2424
- Or
- W1-4L(O)-48
- W13-1(O)-2424

SYMBOLS

- Arrow board
- Cone, drum or barricade
- Sign on portable or permanent support
- Work area
- Barricade or drum with flashing light
- Type III barricade with flashing lights
- Flagger with traffic control sign.

- ① Refer to SIGN SPACING TABLE for distances.
- ② Required for speeds > 40 mph.
- ③ Use flagger sign only when flagger is present.
- ④ For approved sideroad closures.
- ⑤ Cones at 25' (8 m) centers for 250' (75 m). Additional cones may be placed at 50' (15 m) centers. When drums or Type I or Type II barricades are used, the interval between devices may be doubled.
- ⑥ Cones, drums or barricades at 20' (6 m) centers in taper.
- ⑦ Repeat every 1 mile (1.6 km).

GENERAL NOTES

This Standard is used where at any time, day or night, any vehicle, equipment, workers or their activities encroach on the pavement requiring the closure of more than one traffic lane in an Urban area.

Calculate L as follows:

SPEED LIMIT	FORMULAS	
	English	(Metric)
40 mph (70 km/h) or less:	$L = \frac{WS^2}{60}$	$L = \frac{WS^2}{150}$
45 mph (80 km/h) or greater:	$L = (W)(S)$	$L = 0.65(W)(S)$

W = Width of offset in feet (meters).
S = Normal posted speed mph (km/h).

All dimensions are in inches (millimeters) unless otherwise shown.

Illinois Department of Transportation

PASSED April 1, 2016
[Signature]
ENGINEER OF SAFETY ENGINEERING

ISSUED 1-1-15

APPROVED April 1, 2016
[Signature]
ENGINEER OF DESIGN AND ENVIRONMENT

DATE	REVISIONS
4-1-16	Moved first reverse curve/turn sign to middle of tangent.
1-1-15	New Standard.

URBAN HALF ROAD CLOSURE, MULTILANE, 2W WITH MOUNTABLE MEDIAN

STANDARD 701611-01

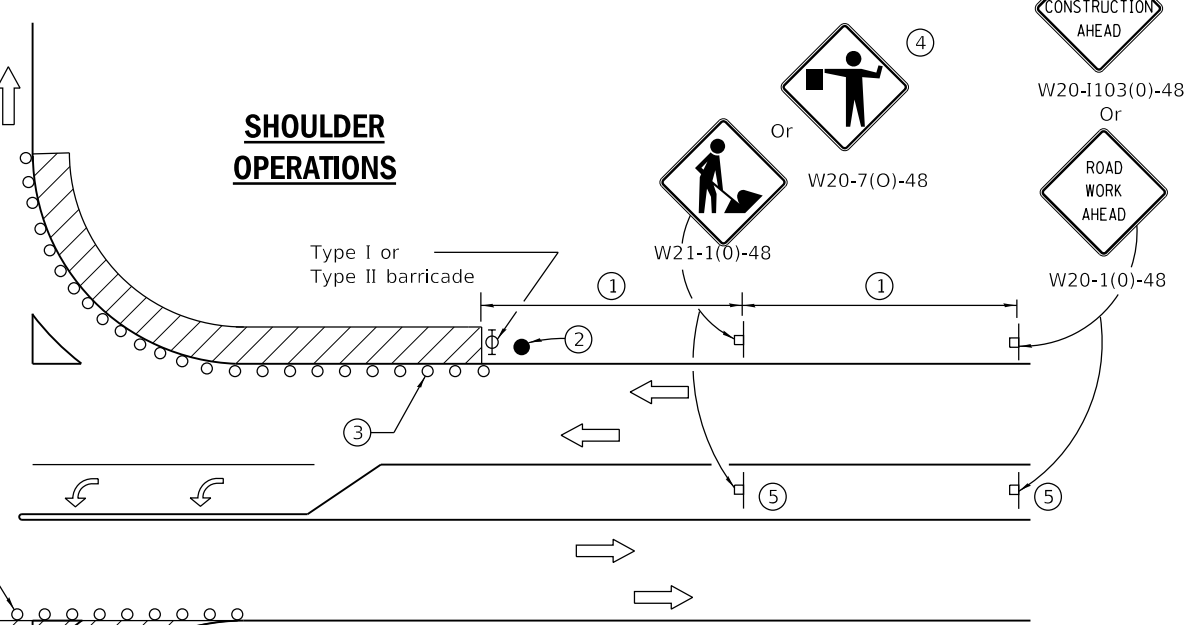
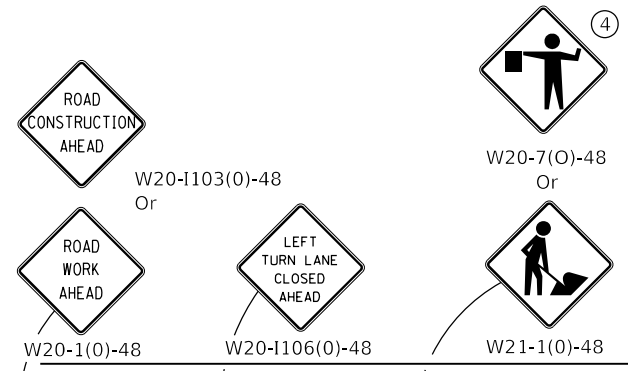

LEFT TURN LANE OR CENTER MEDIAN OPERATIONS

- ① Refer to SIGN SPACING TABLE for distance.
- ② Required for speed > 40 mph.
- ③ Cones at 25' (8 m) centers for 250' (75 m). Additional cones may be placed at 50' (15 m) centers. When drums or Type I or Type II barricades are used, the interval between devices may be doubled.
- ④ Use flagger sign only when flagger is present.
- ⑤ Omit this sign when median is less than 10' (3 m) or for bi-directional turn lanes.
- ⑥ Cones, drums or barricades at 20' (6 m) centers in taper.
- ⑦ Advanced arrow board required for speeds > 45 mph.
- ⑧ Three Type II barricades, drums or vertical barricades at 50' (15 m) centers.

SIGN SPACING	
Posted Speed	Sign Spacing
55	500' (150 m)
50-45	350' (100 m)
<45	200' (60 m)

SYMBOLS

- Work area
- Cone, drum or barricade
- Sign on portable or permanent support
- Arrow board
- Barricade or drum with flashing light
- Flagger with traffic control sign

CORNER ISLAND OPERATIONS

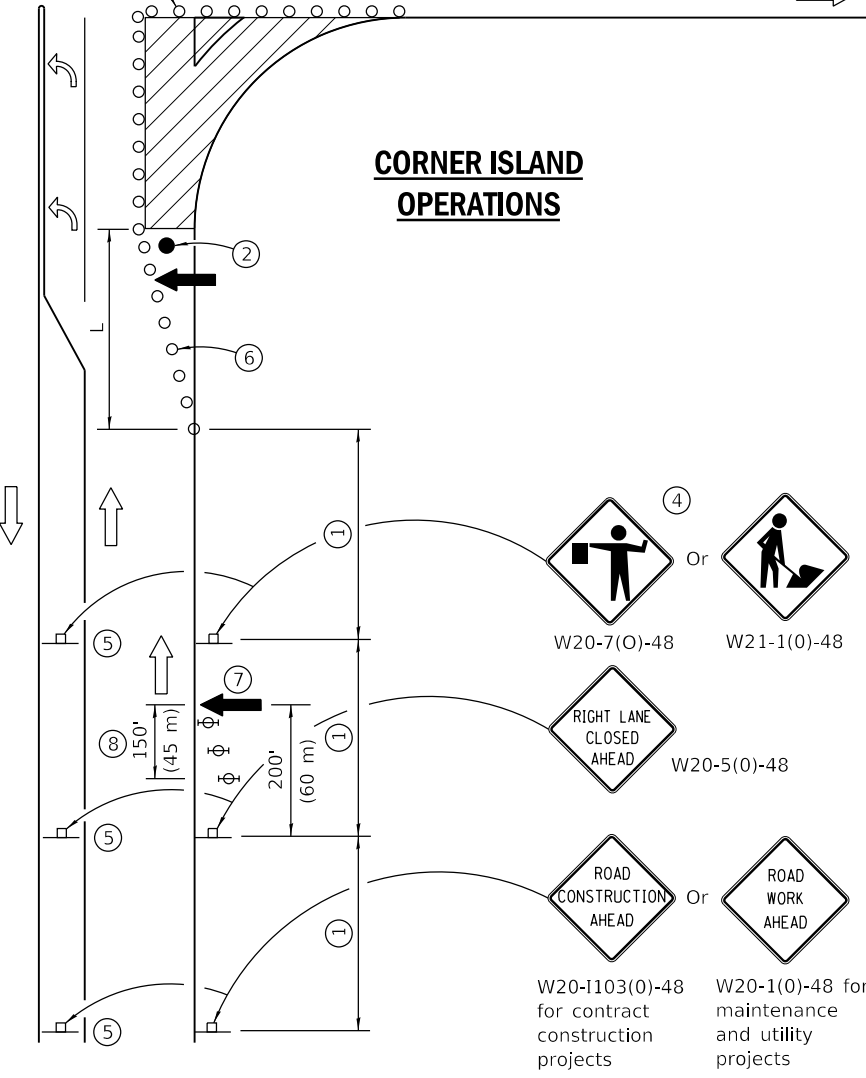

GENERAL NOTES

This Standard is used where at any time, day or night, any vehicle, equipment, workers or their activities encroach on the pavement during shoulder operations or where construction requires lane closures in an urban area.

Calculate L as follows:

SPEED LIMIT	FORMULAS	
	English	(Metric)
40 mph (70 km/h) or less:	$L = \frac{WS^2}{60}$	$L = \frac{WS^2}{150}$
45 mph (80 km/h) or greater:	$L = (W)(S)$	$L = 0.65(W)(S)$

W = Width of offset in feet (meters).

S = Normal posted speed mph (km/h).

All dimensions are in inches (millimeters) unless otherwise shown.

DATE	REVISIONS
4-1-16	Corrected sign number for LEFT TURN LANE CLOSED AHEAD.
1-1-14	Added devices at arrow board upstream from taper.
	Rev. workers sign number.

URBAN LANE CLOSURE, MULTILANE INTERSECTION

STANDARD 701701-10

Illinois Department of Transportation

PASSED April 1, 2016

 ENGINEER OF SAFETY ENGINEERING

APPROVED April 1, 2016

 ENGINEER OF DESIGN AND ENVIRONMENT

ISSUED 1-1-97

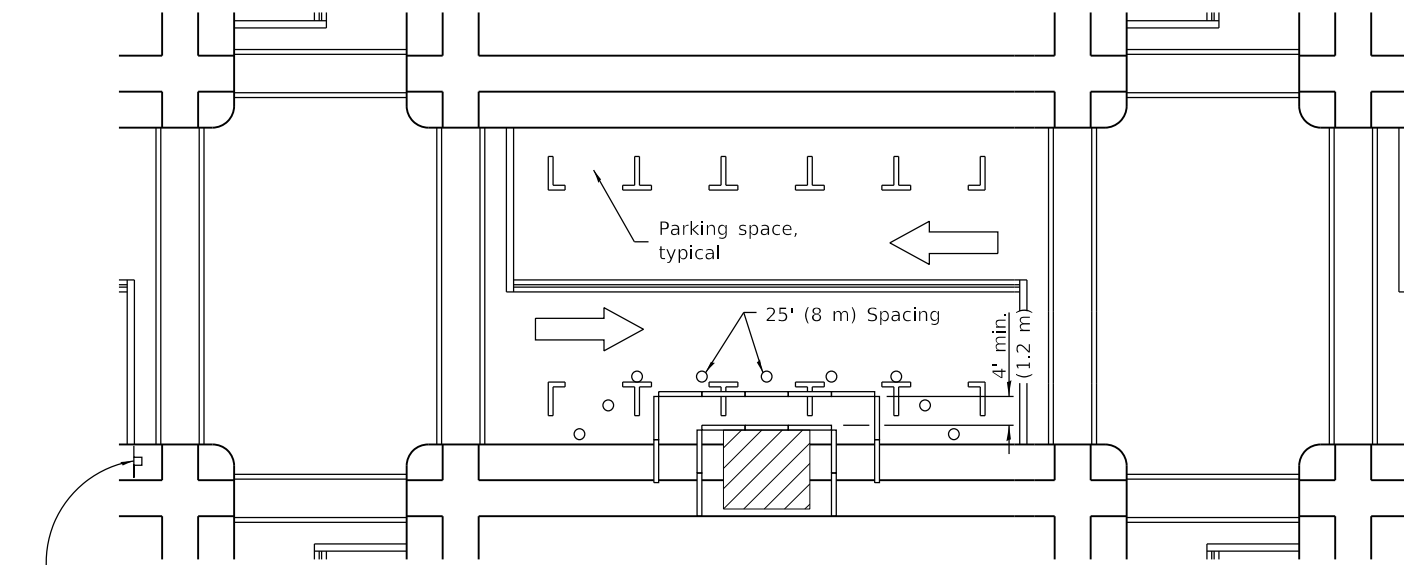

① ROAD CONSTRUCTION AHEAD
W20-1103(0)-48 for contract construction projects

Or
① ROAD WORK AHEAD
W20-1(0)-48 for maintenance and utility projects

SIDEWALK DIVERSION

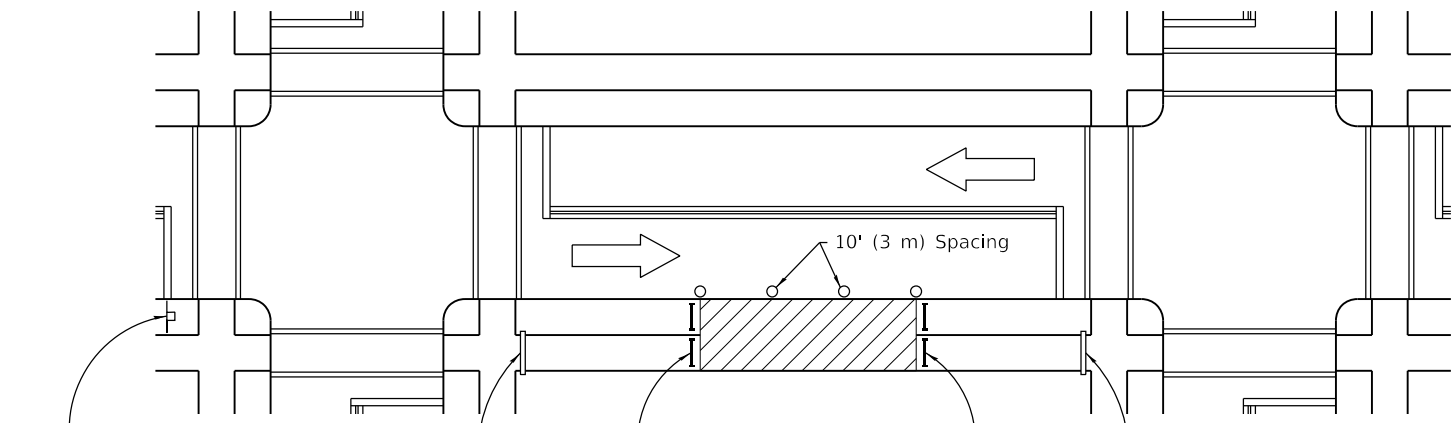

① ROAD CONSTRUCTION AHEAD
W20-1103(0)-48 for contract construction projects

Or
① ROAD WORK AHEAD
W20-1(0)-48 for maintenance and utility projects

SIDEWALK CLOSED
←
USE OTHER SIDE
R11-1102-2430

SIDEWALK CLOSED
R11-1101-2418

SIDEWALK CLOSED
→
USE OTHER SIDE
R11-1102-2430

SIDEWALK CLOSURE

① Omit whenever duplicated by road work traffic control.

GENERAL NOTES

This Standard is used where, at any time, pedestrian traffic must be rerouted due to work being performed.

This Standard must be used in conjunction with other Traffic Control & Protection Standards when roadway traffic is affected.

Temporary facilities shall be detectable and accessible.

The temporary pedestrian facilities shall be provided on the same side of the closed facilities whenever possible.

The SIDEWALK CLOSED / USE OTHER SIDE sign shall be placed at the nearest crosswalk or intersection to each end of the closure. Where the closure occurs at a corner, the signs shall be erected on the corners across the street from the closure. The SIDEWALK CLOSED signs shall be used at the ends of the actual closures.

Type III barricades and R11-2-4830 signs shall be positioned as shown in "ROAD CLOSED TO ALL TRAFFIC" detail on Standard 701901.

All dimensions are in inches (millimeters) unless otherwise shown.

SYMBOLS

- Work area
- Sign on portable or permanent support
- Barricade or drum
- Cone, drum or barricade
- Type III barricade
- Detectable pedestrian channelizing barricade

Illinois Department of Transportation

PASSED April 1, 2016
[Signature]
ENGINEER OF SAFETY ENGINEERING

APPROVED April 1, 2016
[Signature]
ENGINEER OF DESIGN AND ENVIRONMENT

ISSUED 1-1-97

DATE	REVISIONS
4-1-16	Omitted orange safety fence from standard as this is covered in the std. spec.
1-1-12	Added SIDEWALK DIVERSION. Modified appearance of plan views. Renamed Std.

SIDEWALK, CORNER OR CROSSWALK CLOSURE

(Sheet 1 of 2)

STANDARD 701801-06

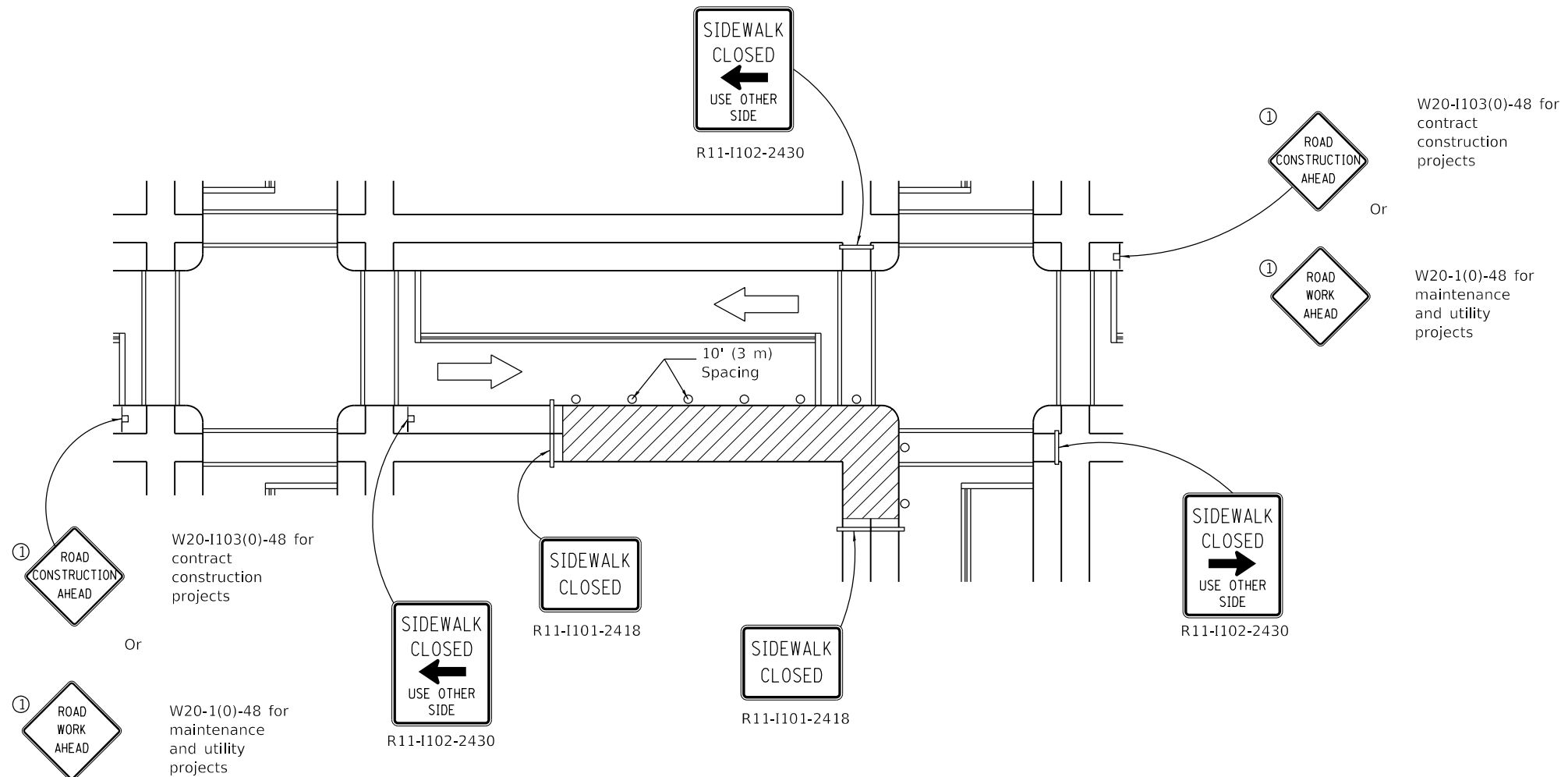

CORNER CLOSURE

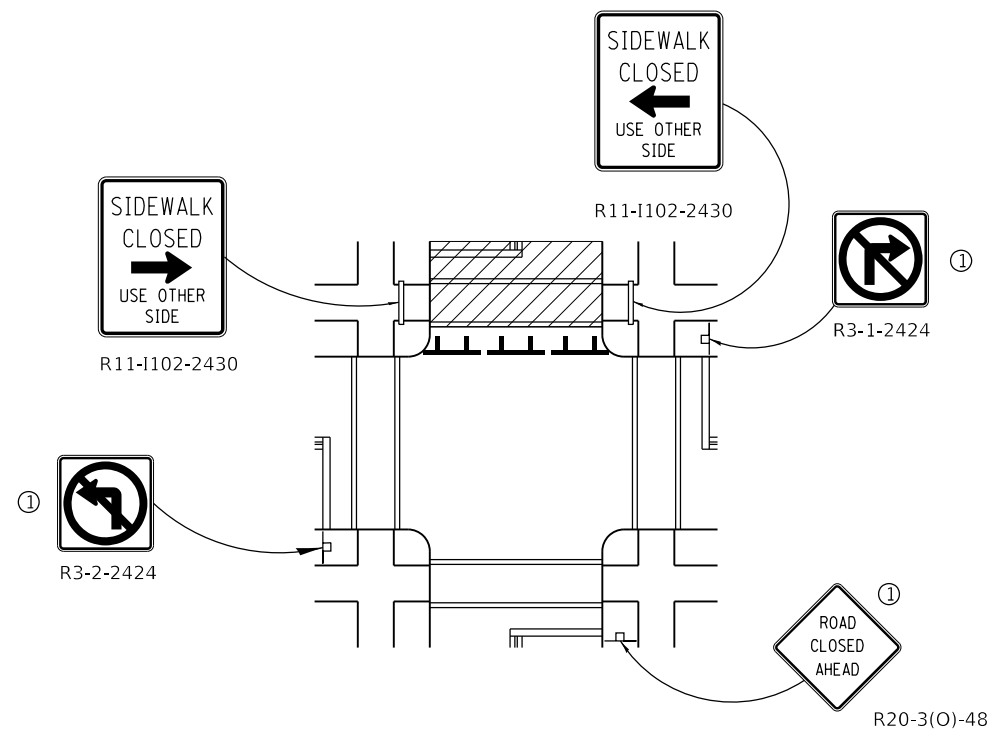

CROSSWALK CLOSURE

W20-I103(0)-48 for contract construction projects

Or

W20-1(0)-48 for maintenance and utility projects

SIDEWALK, CORNER OR CROSSWALK CLOSURE

(Sheet 2 of 2)

STANDARD 701801-06

Illinois Department of Transportation

PASSED April 1, 2016

[Signature]
ENGINEER OF SAFETY ENGINEERING

APPROVED April 1, 2016

[Signature]
ENGINEER OF DESIGN AND ENVIRONMENT

ISSUED 1-1-97

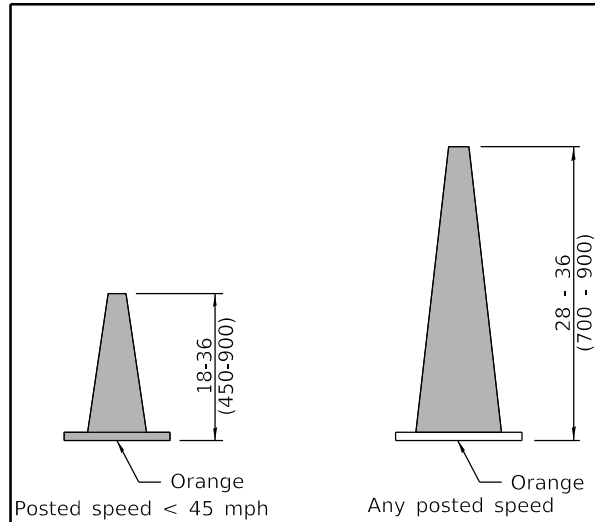

DAYTIME USE

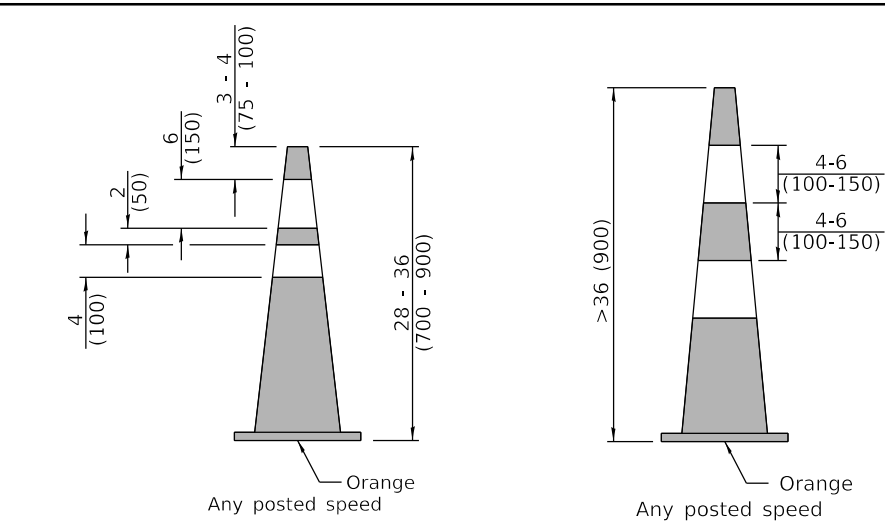

DAY OR NIGHTTIME USE

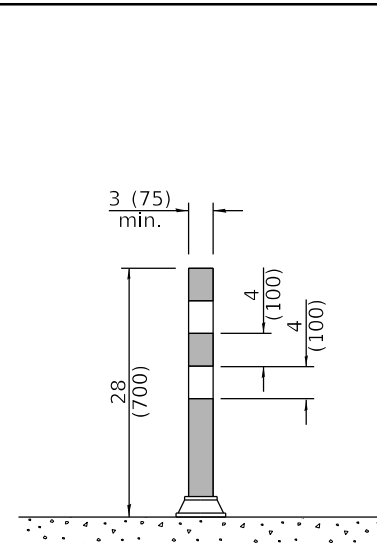

TUBULAR MARKER

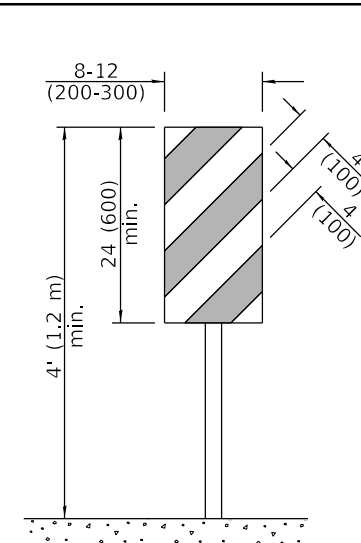

**VERTICAL PANEL
POST MOUNTED**

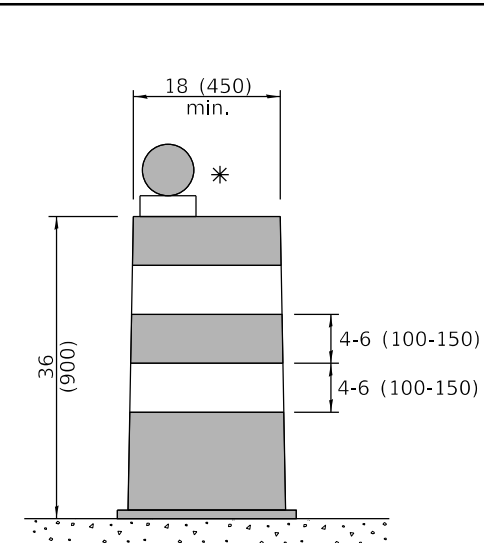

DRUM

CONES

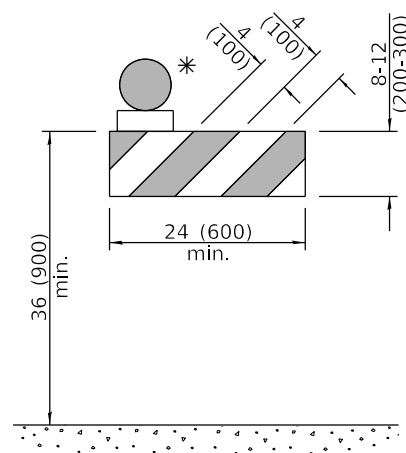

TYPE I BARRICADE

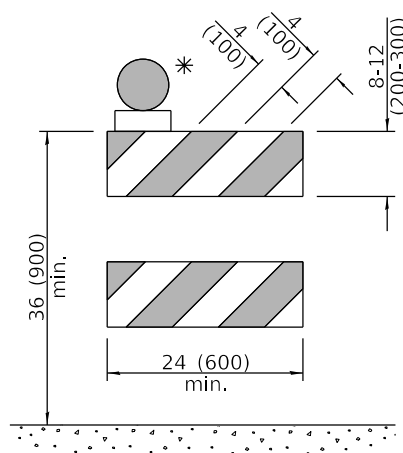

TYPE II BARRICADE

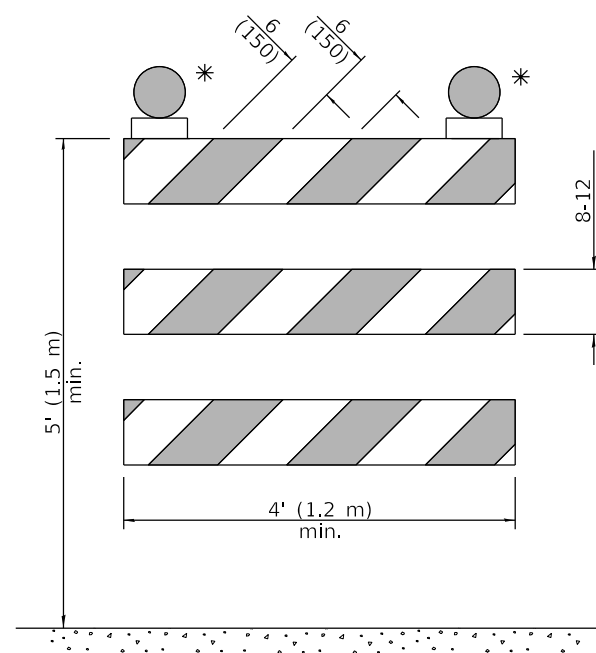

TYPE III BARRICADE

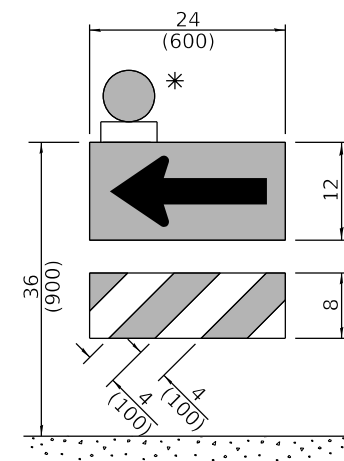

**DIRECTION INDICATOR
BARRICADE**

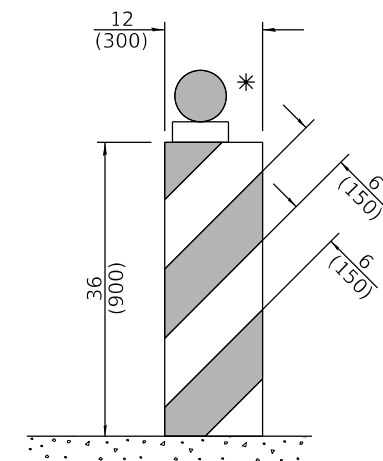

VERTICAL BARRICADE

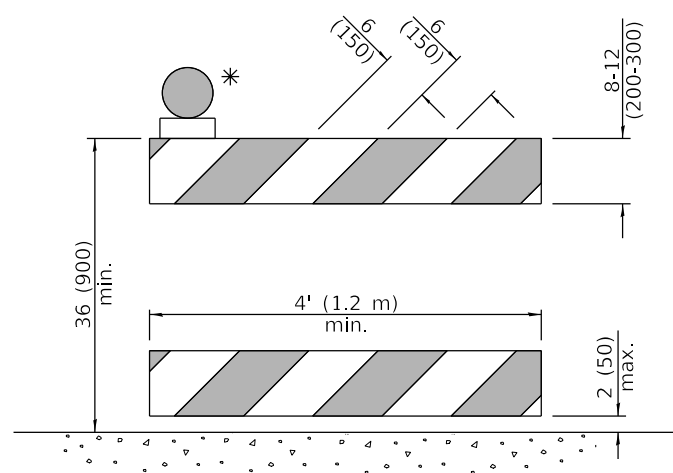

**DETECTABLE PEDESTRIAN
CHANNELIZING BARRICADE**

* Warning lights (if required)

GENERAL NOTES

All heights shown shall be measured above the pavement surface.

All dimensions are in inches (millimeters) unless otherwise shown.

DATE	REVISIONS
1-1-19	Revised cone usage and added cones >36" (900 m) height.
1-1-18	Revised END WORK ZONE SPEED LIMIT sign from orange to white background.

TRAFFIC CONTROL DEVICES

(Sheet 1 of 3)

STANDARD 701901-08

Illinois Department of Transportation

APPROVED January 1, 2019

 ENGINEER OF SAFETY PROG. AND ENGINEERING

APPROVED January 1, 2019

 ENGINEER OF DESIGN AND ENVIRONMENT

ISSUED
 ET-1-1 08/SS1

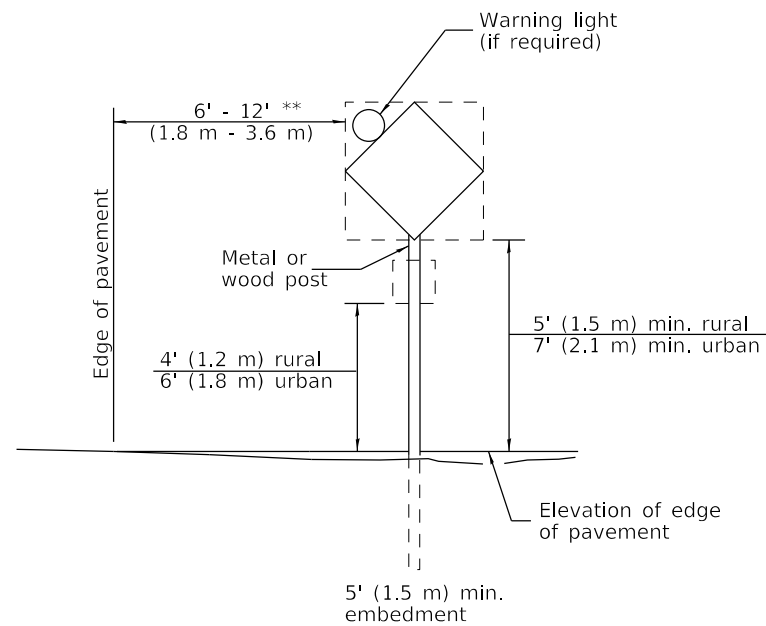

POST MOUNTED SIGNS

** When curb or paved shoulder are present this dimension shall be 24 (600) to the face of curb or 6' (1.8 m) to the outside edge of the paved shoulder.

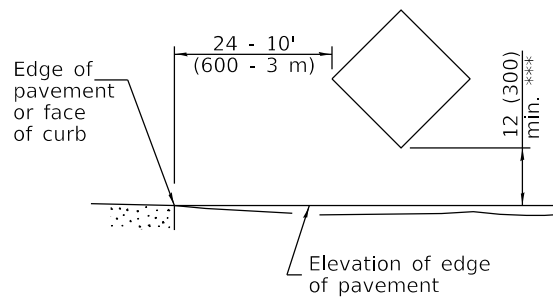

SIGNS ON TEMPORARY SUPPORTS

*** When work operations exceed four days, this dimension shall be 5' (1.5 m) min. If located behind other devices, the height shall be sufficient to be seen completely above the devices.

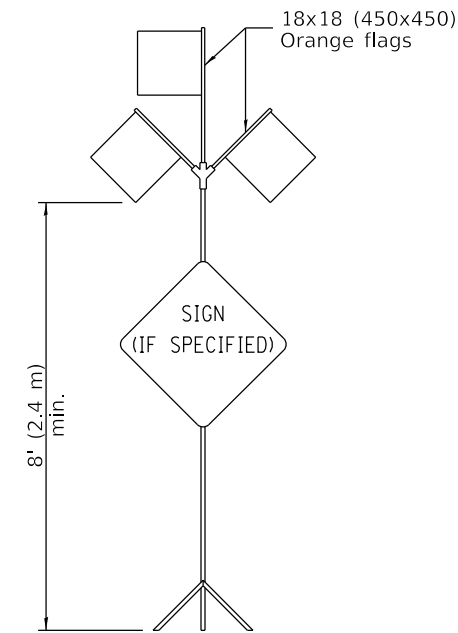

HIGH LEVEL WARNING DEVICE

ROAD CONSTRUCTION NEXT X MILES	END CONSTRUCTION
G20-I104(0)-6036	G20-I105(0)-6024

This signing is required for all projects 2 miles (3200 m) or more in length.
 ROAD CONSTRUCTION NEXT X MILES sign shall be placed 500' (150 m) in advance of project limits.
 END CONSTRUCTION sign shall be erected at the end of the job unless another job is within 2 miles (3200 m).
 Dual sign displays shall be utilized on multi-lane highways.

WORK LIMIT SIGNING

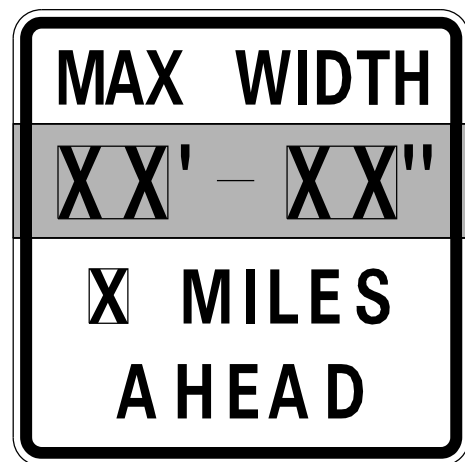

W12-I103-4848

WIDTH RESTRICTION SIGN

XX'-XX" width and X miles are variable.

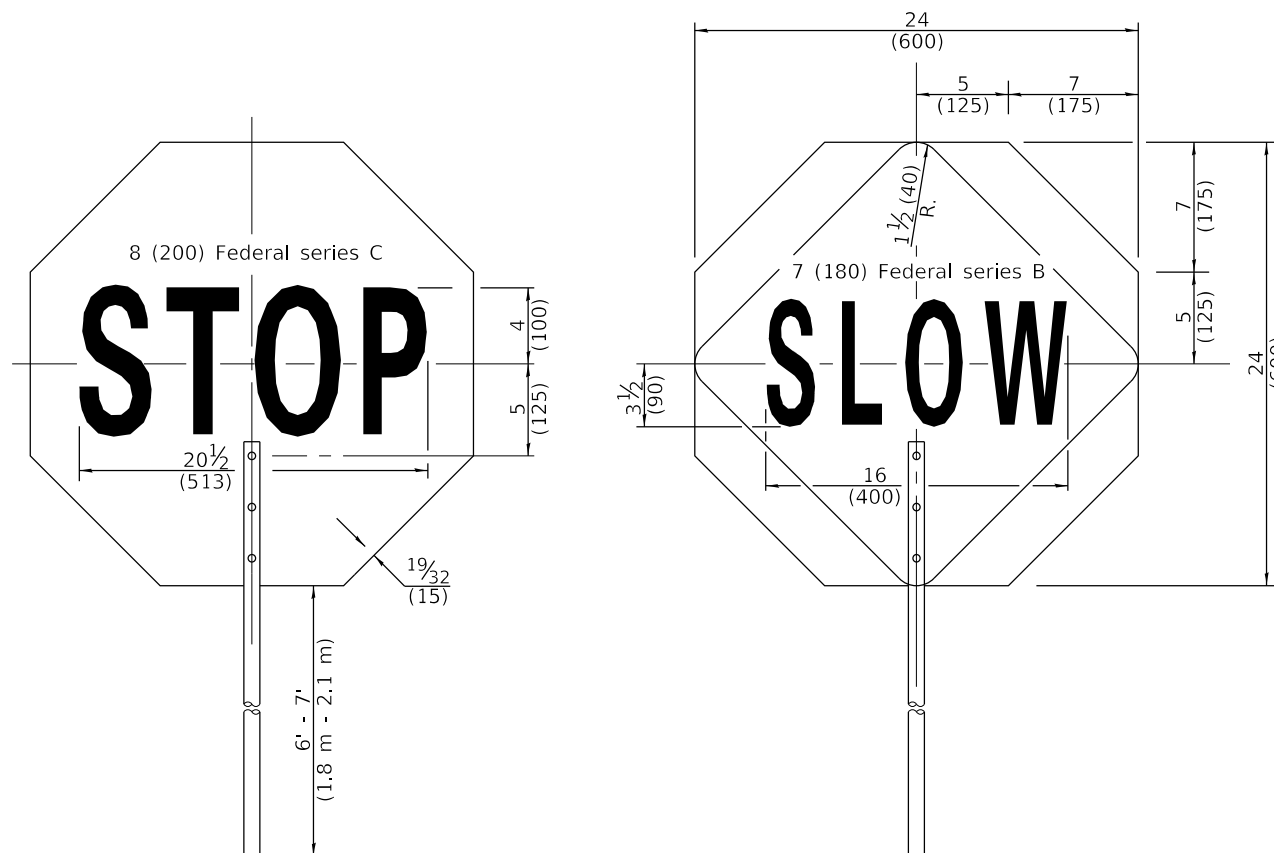

FRONT SIDE

REVERSE SIDE

FLAGGER TRAFFIC CONTROL SIGN

WORK ZONE	W21-III5(0)-3618
SPEED LIMIT XX	R2-1-3648
PHOTO ENFORCED	R10-I108p-3618 ****
\$XXX FINE MINIMUM	R2-I106p-3618

Sign assembly as shown on Standards or as allowed by District Operations.

END WORK ZONE SPEED LIMIT	G20-I103-6036
---------------------------	---------------

This sign shall be used when the above sign assembly is used.

HIGHWAY CONSTRUCTION SPEED ZONE SIGNS

**** R10-I108p shall only be used along roadways under the jurisdiction of the State.

Illinois Department of Transportation

APPROVED January 1, 2019
Cynthia Watt
 ENGINEER OF SAFETY PROG. AND ENGINEERING

APPROVED January 1, 2019
J. E. ...
 ENGINEER OF DESIGN AND ENVIRONMENT

ISSUED 1-1-13

TRAFFIC CONTROL DEVICES

(Sheet 2 of 3)

STANDARD 701901-08

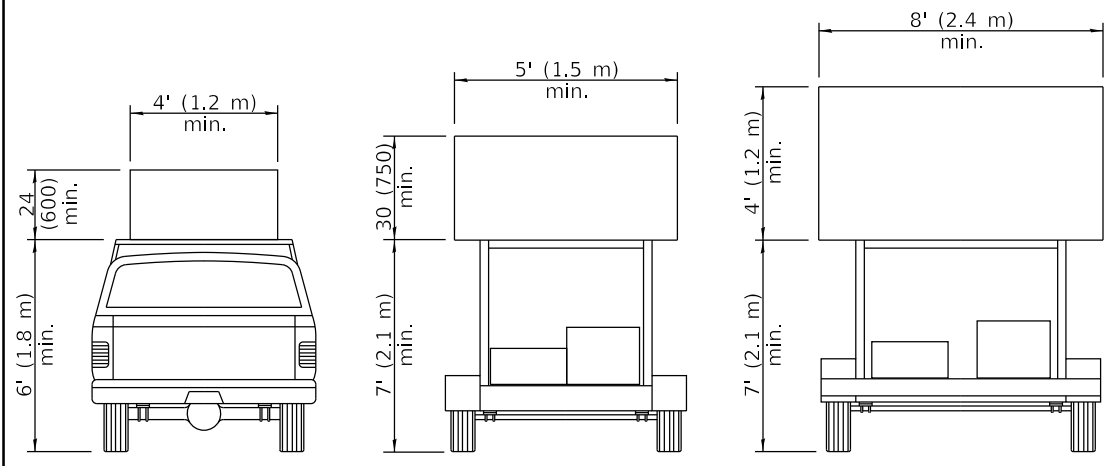

**TYPE A
ROOF
MOUNTED**

**TYPE B
ROOF OR TRAILER
MOUNTED**

**TYPE C
TRAILER
MOUNTED**

ARROW BOARDS

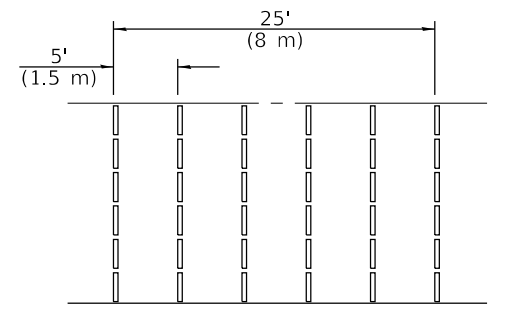
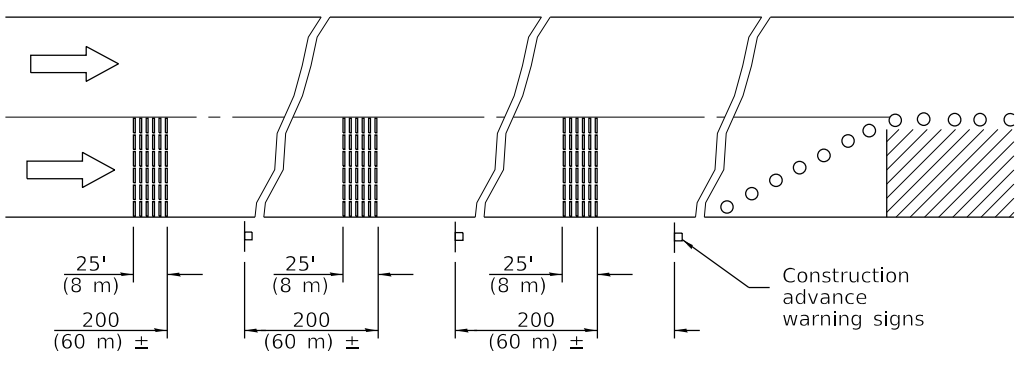
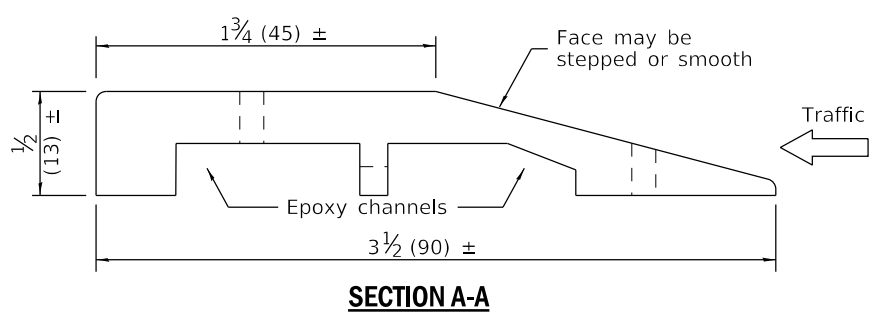
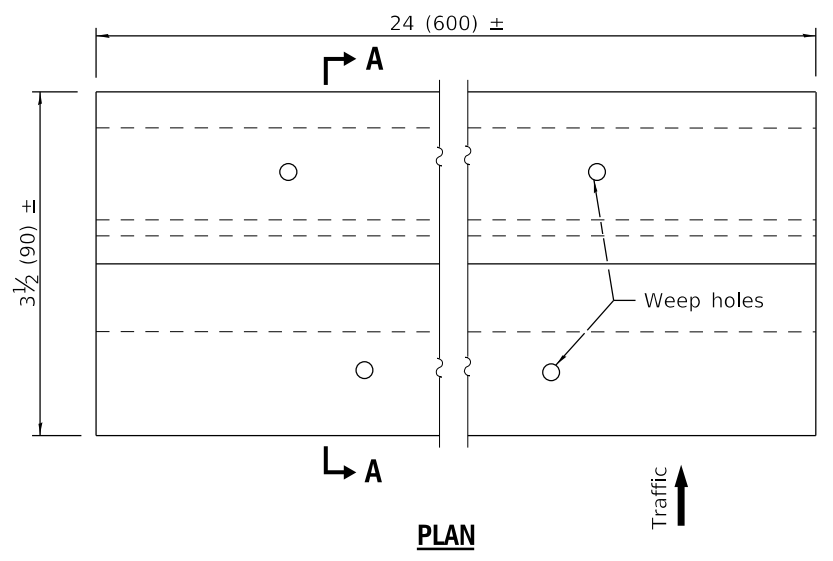

TEMPORARY RUMBLE STRIPS

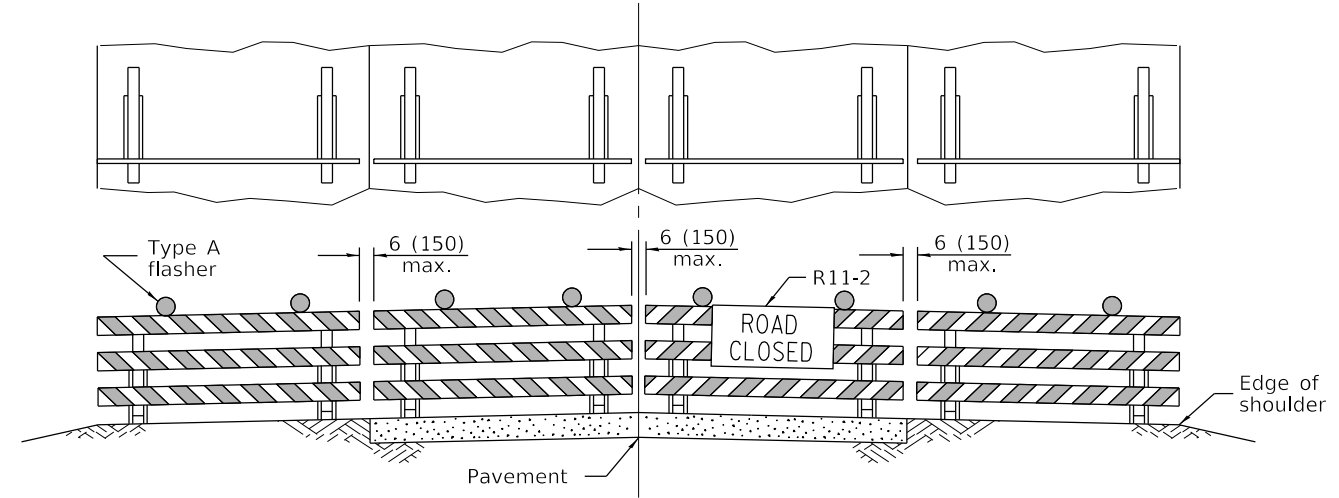

ROAD CLOSED TO ALL TRAFFIC

Reflectorized striping may be omitted on the back side of the barricades. If a Type III barricade with an attached sign panel which meets NCHRP 350 is not available, the sign may be mounted on an NCHRP 350 temporary sign support directly in front of the barricade.

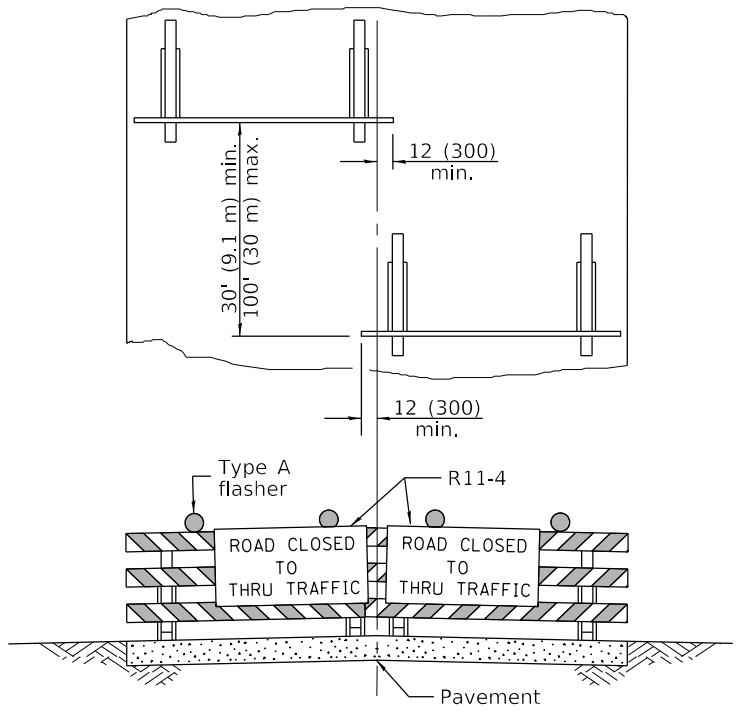

ROAD CLOSED TO THRU TRAFFIC

Reflectorized striping shall appear on both sides of the barricades. If a Type III barricade with an attached sign panel which meets NCHRP 350 is not available, the signs may be mounted on NCHRP 350 temporary sign supports directly in front of the barricade.

**TYPICAL APPLICATIONS OF
TYPE III BARRICADES CLOSING A ROAD**

**TRAFFIC CONTROL
DEVICES**

(Sheet 3 of 3)

STANDARD 701901-08

Illinois Department of Transportation

APPROVED January 1, 2019

Cynthia Watt
ENGINEER OF SAFETY PROG. AND ENGINEERING

APPROVED January 1, 2019

Joe E. ...
ENGINEER OF DESIGN AND ENVIRONMENT

ISSUES
E1-1-1 Q3581

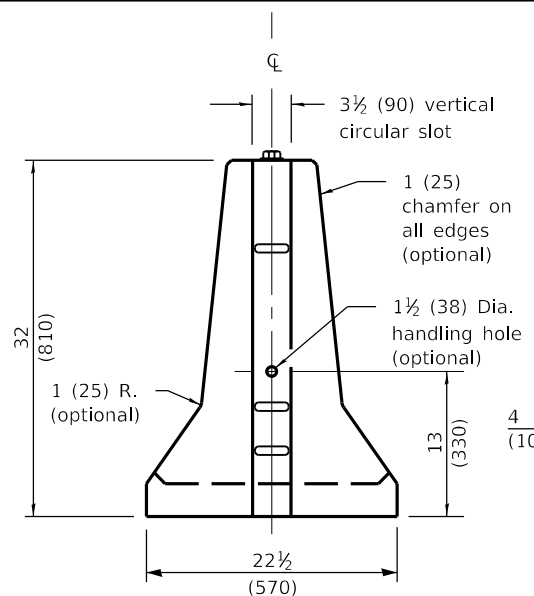

END VIEW
(Showing lifting slot)

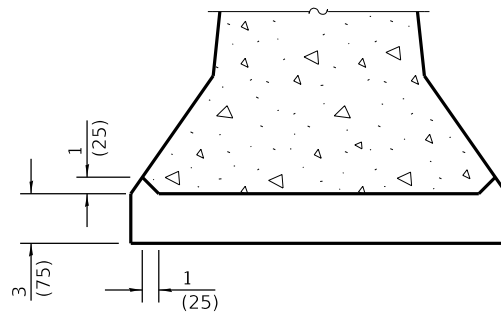

SECTION A-A
LIFTING SLOT

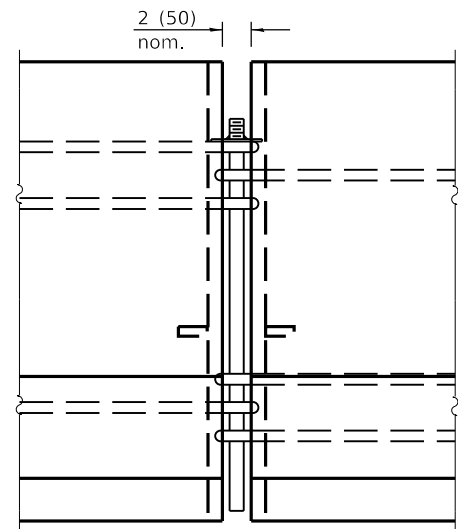

CONNECTING DETAIL

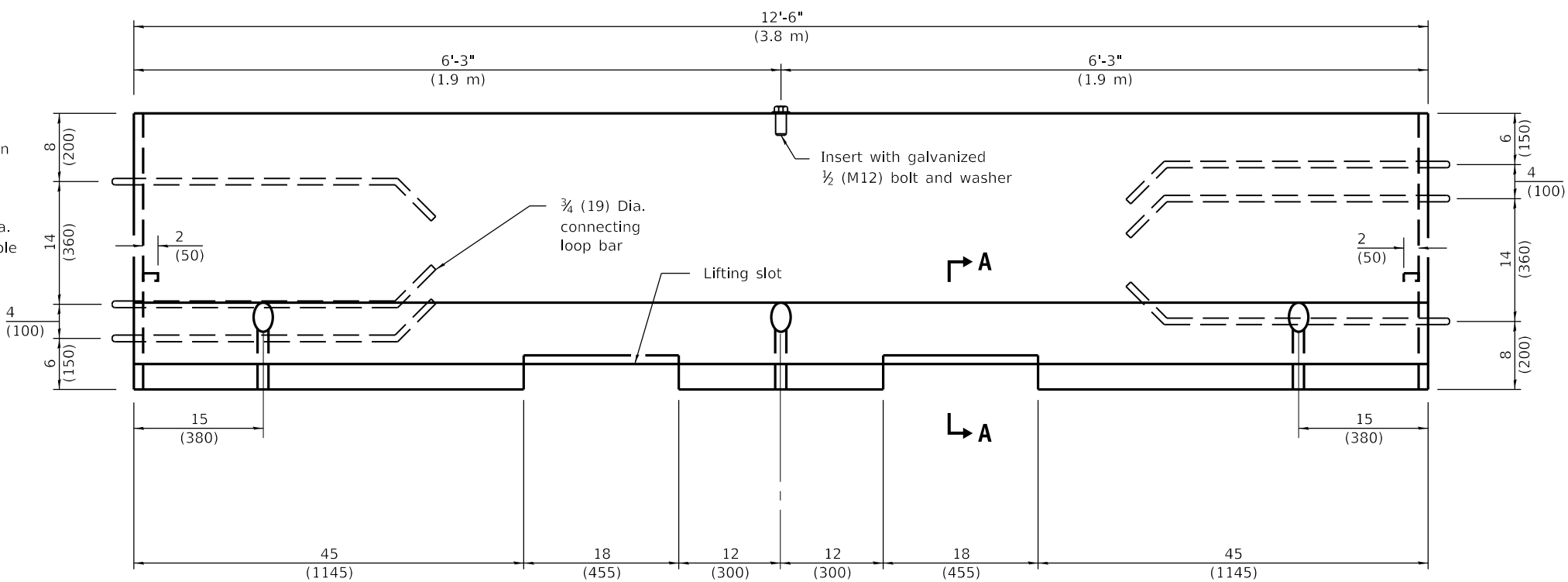

ELEVATION
(Showing connecting loop bars and vertical panel bolt/insert)

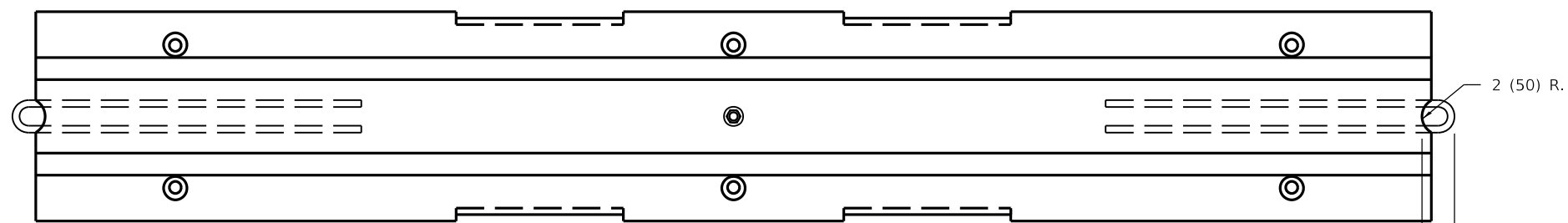

PLAN

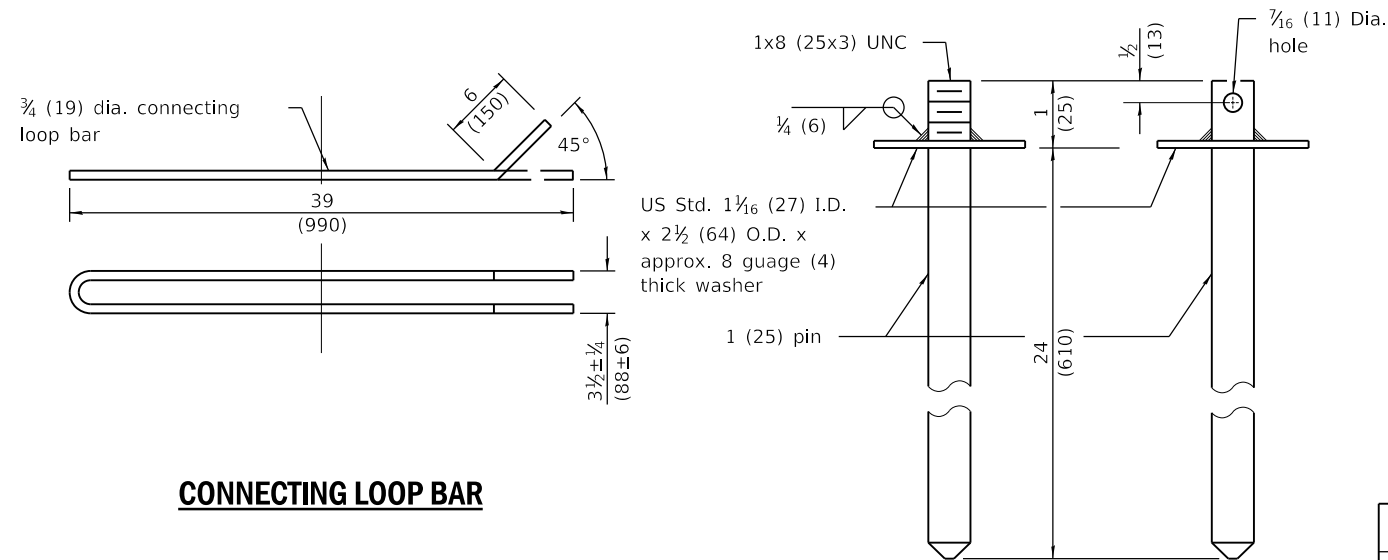

CONNECTING LOOP BAR

CONNECTING AND
ANCHOR PINS

(End may be beveled 1/4 (6) max.)

F SHAPE DESIGN

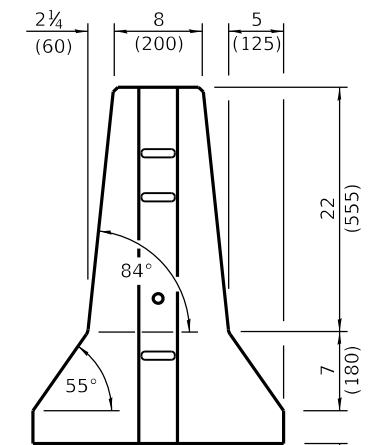

END VIEW

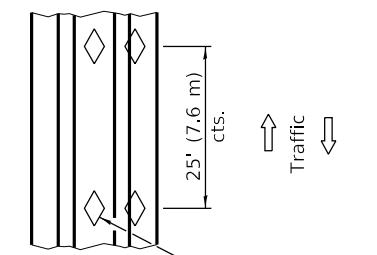

TOP VIEW

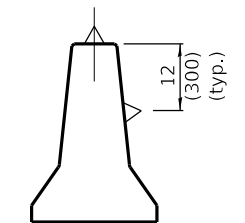

BARRIER WALL REFLECTORS

GENERAL NOTES

Each F shape barrier shall be clearly marked with "ILLINOIS F SHAPE", the Producer's mark and the date of manufacture. The markings shall be indented on the barrier or painted thereon with waterproof paint/ink.

The insert for the 1/2 (M12) bolt shall be capable of 3,000 lb (13 kN) pull-out strength.

When barrier separates opposing flows of traffic markers shall be on both sides of barrier.

See Standard 782006 for dimensions of Type C reflector.

All dimensions are in inches (millimeters) unless otherwise shown.

2 1/2 (63) measured from face of barrier to end of loop bar

DATE	REVISIONS
4-1-16	Rev. opt. chamfer on all edges to 1 (25). Reference to Std. 635011 now 782006.
1-1-12	Omitted 'ALTERNATE' from connecting and anchoring pins detail.

TEMPORARY CONCRETE BARRIER

(Sheet 1 of 2)

STANDARD 704001-08

Illinois Department of Transportation

PASSED April 1, 2016
Michael Brand
ENGINEER OF POLICY AND PROCEDURES

APPROVED April 1, 2016
ENGINEER OF DESIGN AND ENVIRONMENT

ISSUED 20-1-10-08

F SHAPE DESIGN

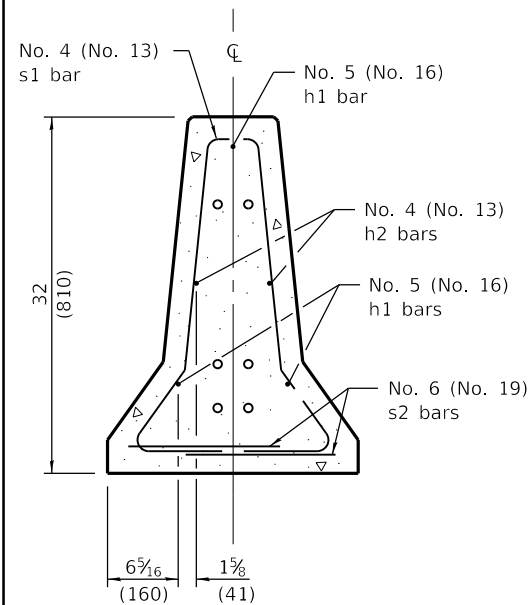

SECTION C-C

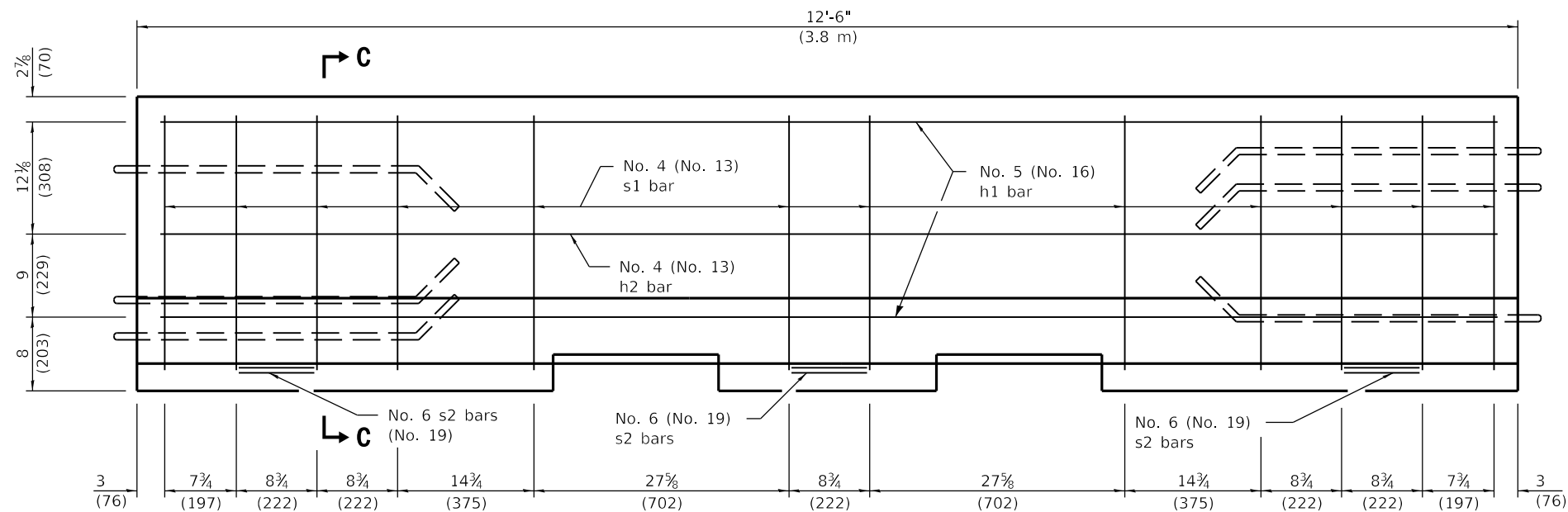

ELEVATION
(Reinforcement)

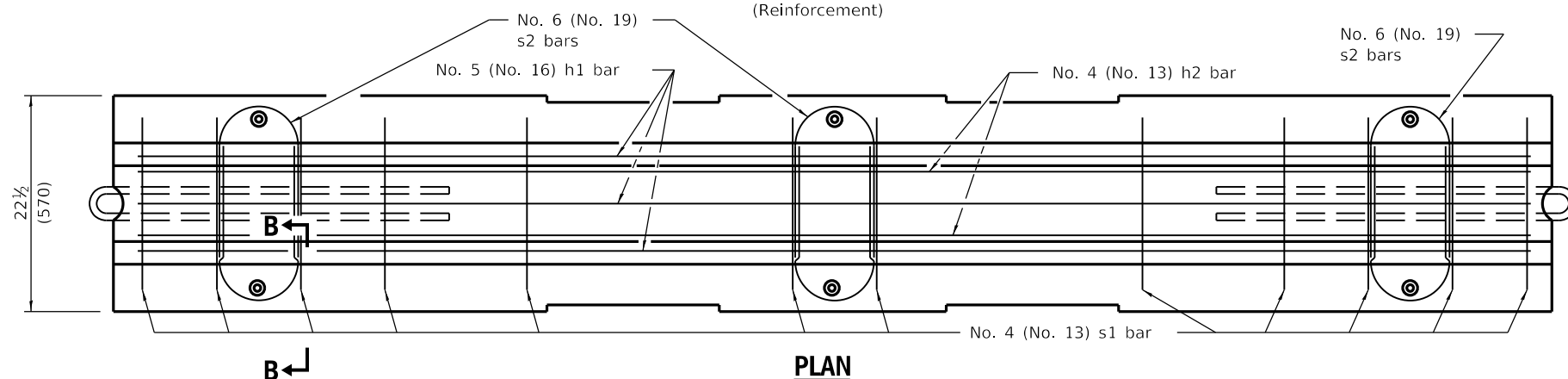

PLAN

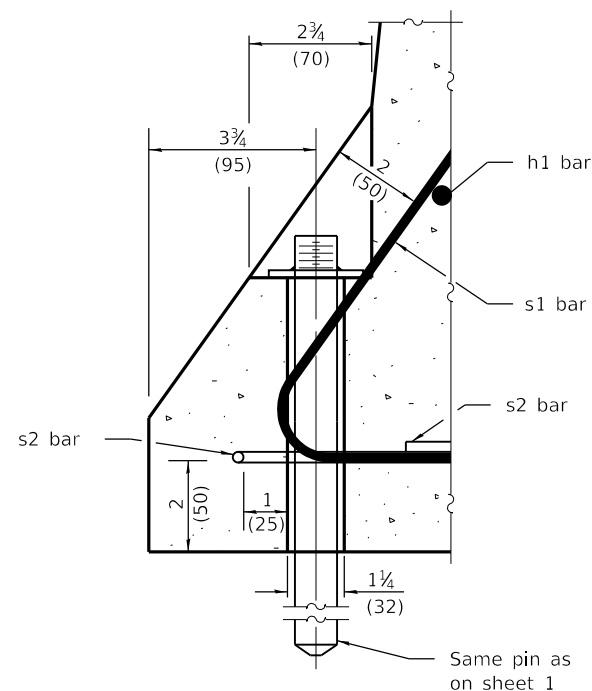

SECTION B-B
ANCHORING DETAIL

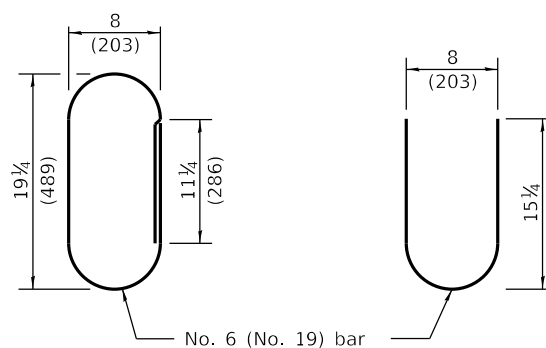

ALTERNATE s2 BARS

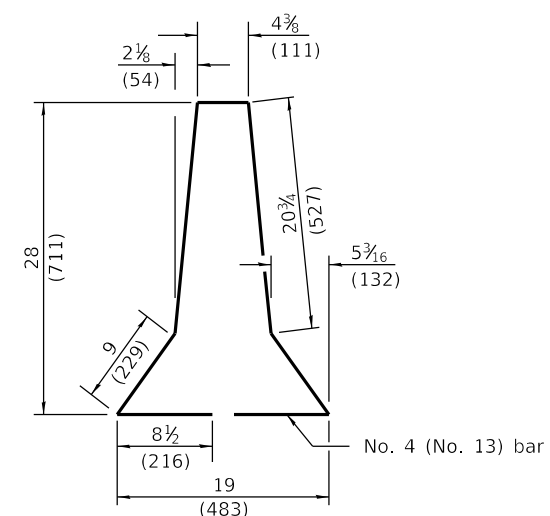

s1 BAR

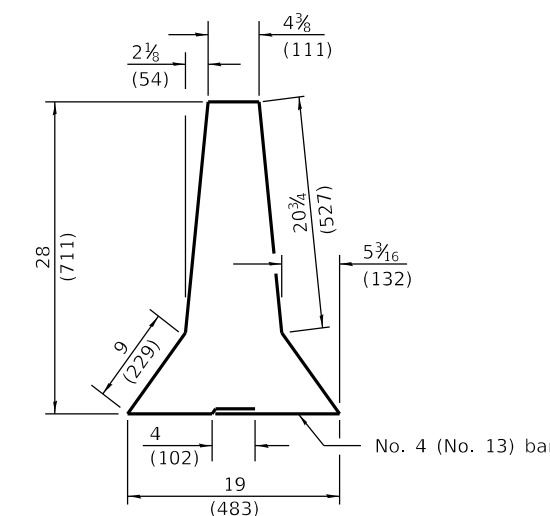

ALTERNATE s1 BAR

Illinois Department of Transportation

PASSED April 1, 2016

Michael Beard
ENGINEER OF POLICY AND PROCEDURES

APPROVED April 1, 2016

[Signature]
ENGINEER OF DESIGN AND ENVIRONMENT

ISSUED 10-1-02

TEMPORARY CONCRETE BARRIER

(Sheet 2 of 2)

STANDARD 704001-08

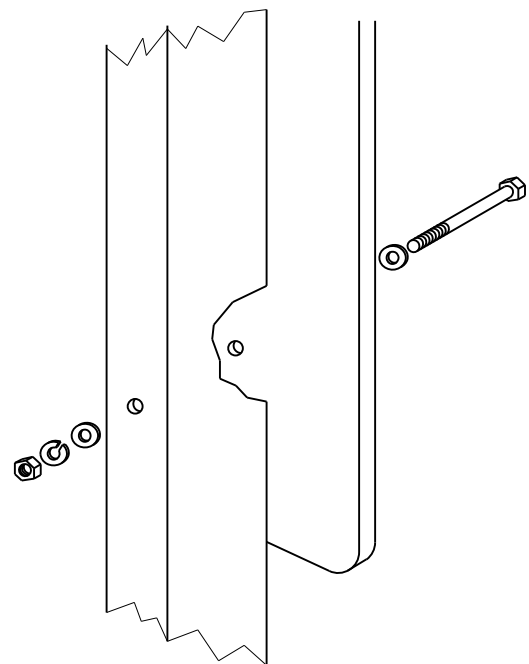

Sign panel 36 (900) wide or less

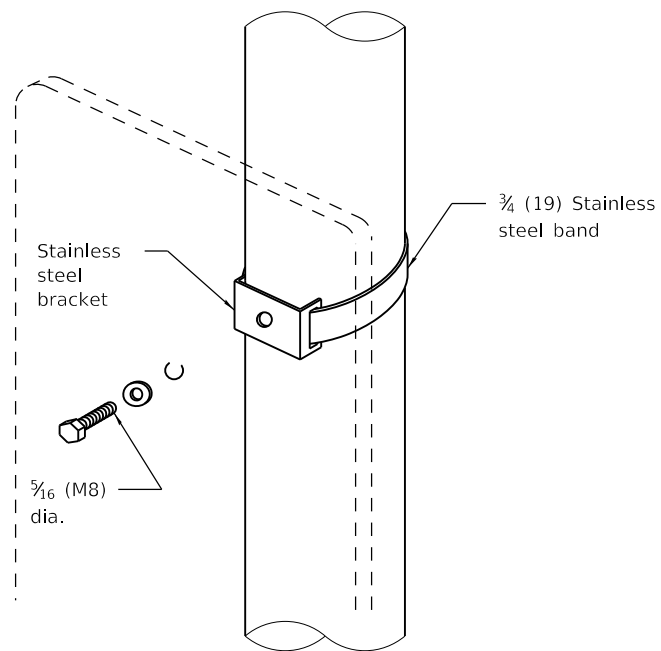

Sign panel 36 (900) wide or less

Section modulus (minimum)	Axis A	Axis B
Steel	0.050 in. ³ (819 mm ³)	0.105 in. ³ (1720 mm ³)
Aluminum	0.150 in. ³ (2458 mm ³)	0.315 in. ³ (5162 mm ³)

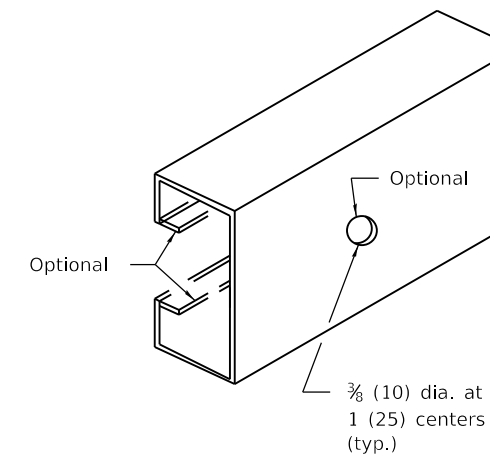
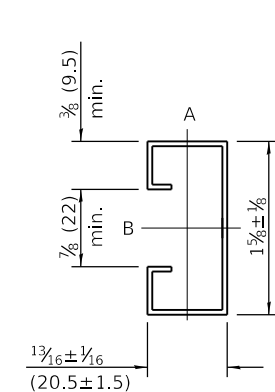

SUPPORTING CHANNEL DETAILS

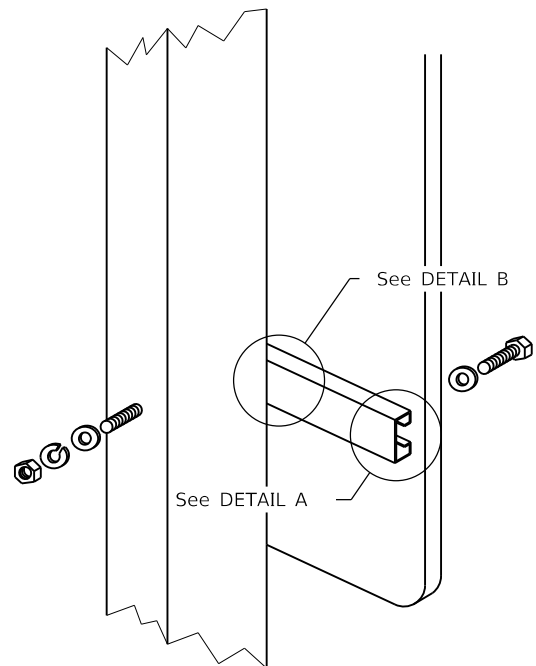

Sign panel over 36 (900) wide

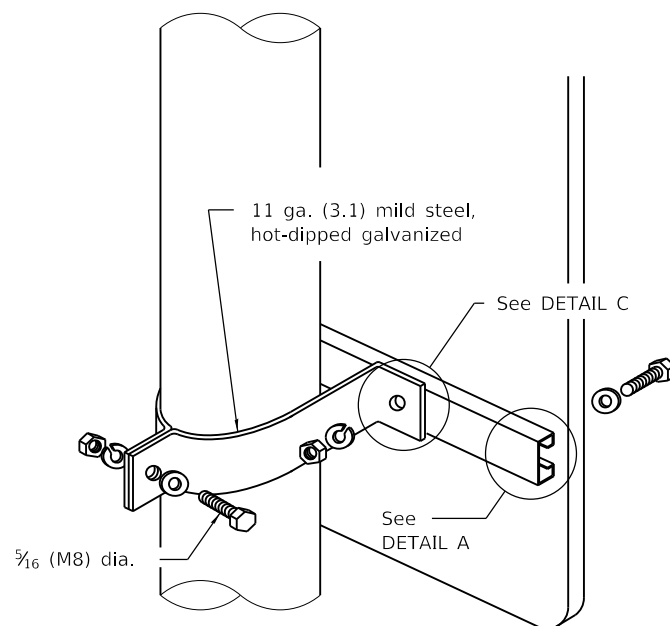

Sign panel over 36 (900) wide

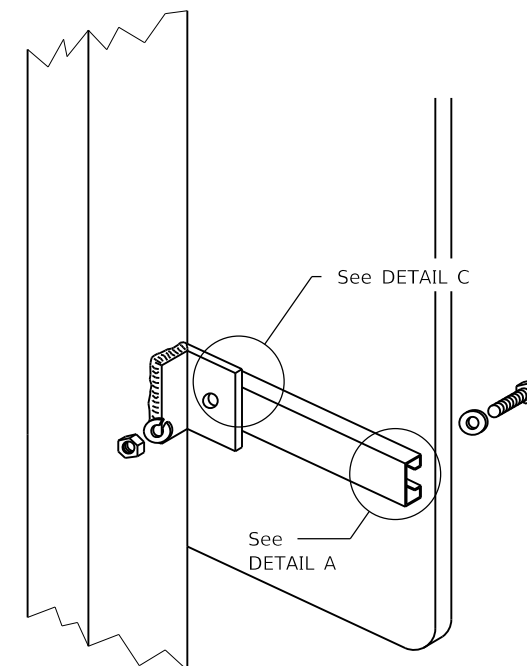

ROUTE MARKER ASSEMBLY

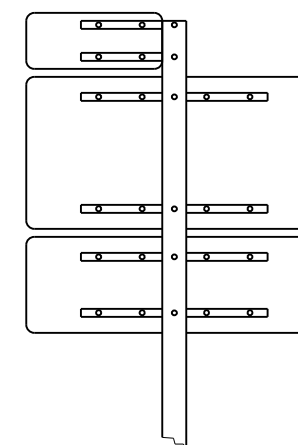

WOOD OR TELESCOPING STEEL POSTS

LIGHT OR SIGNAL STANDARDS

BREAKAWAY STEEL TUBING POSTS
(All sign panel sizes)

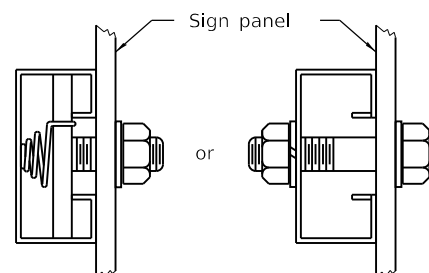

DETAIL A

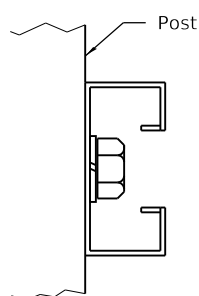

DETAIL B

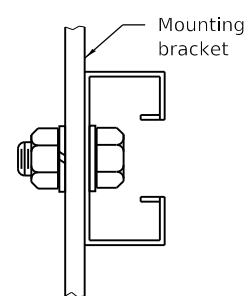

DETAIL C

All dimensions are in inches (millimeters) unless otherwise shown.

DATE	REVISIONS
1-1-09	Switched units to English (metric).
1-1-97	Renum. Standard 2319-6.

SIGN PANEL MOUNTING DETAILS

STANDARD 720001-01

Illinois Department of Transportation

PASSED January 1, 2009

ENGINEER OF OPERATIONS

APPROVED January 1, 2009

ENGINEER OF DESIGN AND ENVIRONMENT

ISSUED 1-1-97

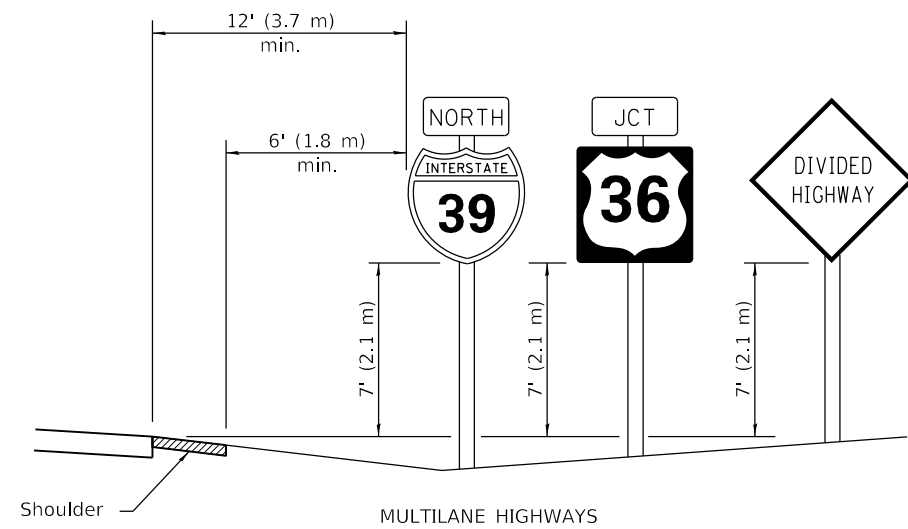

MULTILANE HIGHWAYS

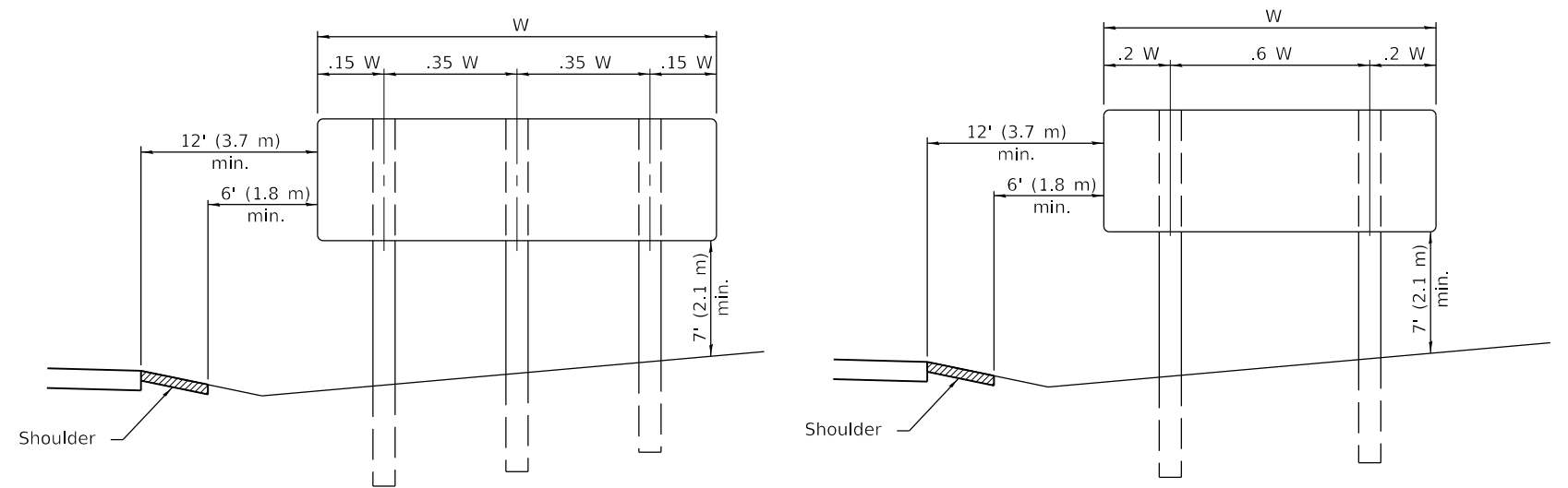

POST SPACING FOR NON-FREEWAY SIGN PANELS

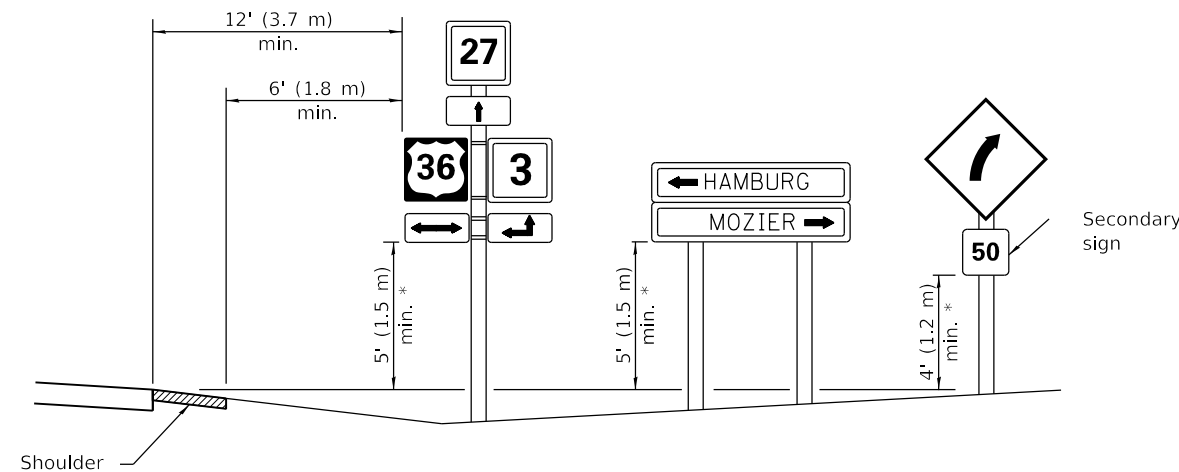

* In any area where parking is likely to occur or where there are obstructions to view or where signs are located over sidewalks, the height shall be at least 7' (2.1 m).

TWO LANE RURAL HIGHWAYS

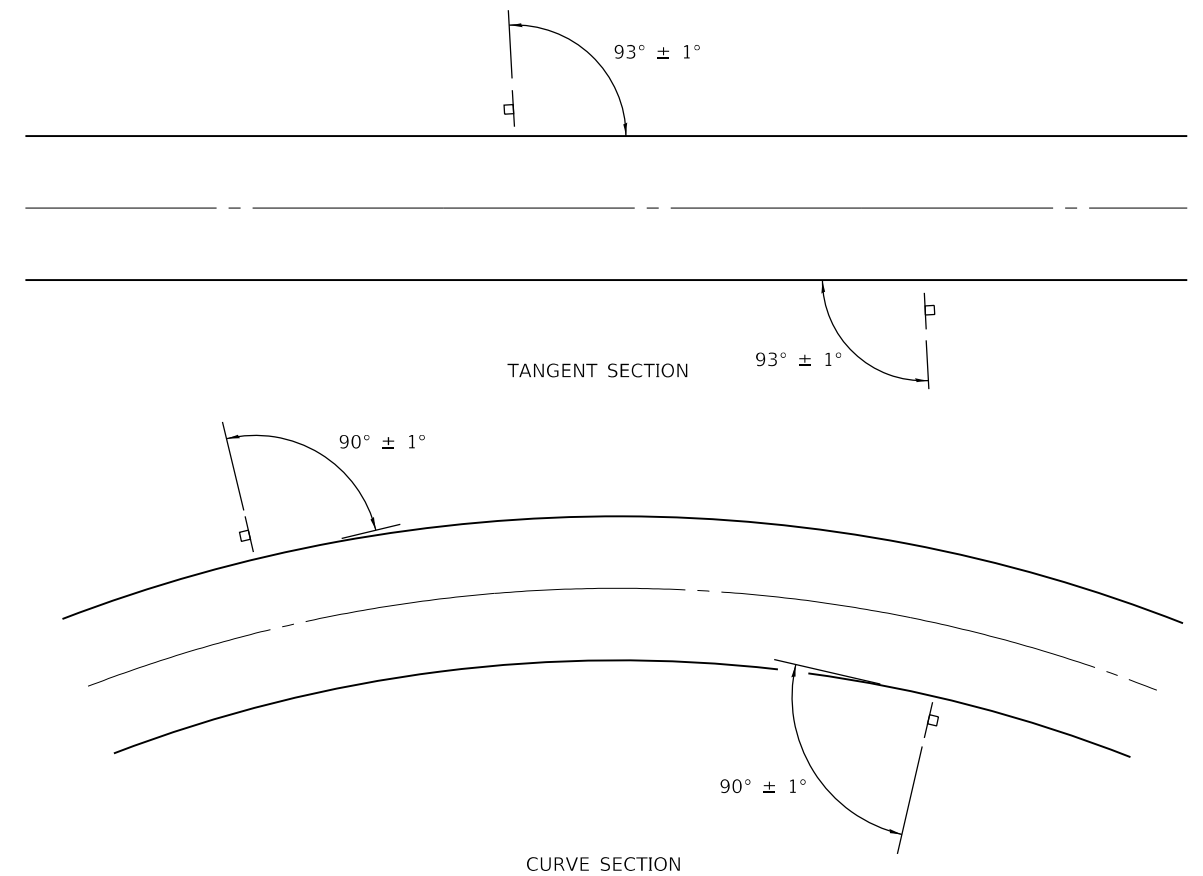

GROUND MOUNT SIGN POSITIONING

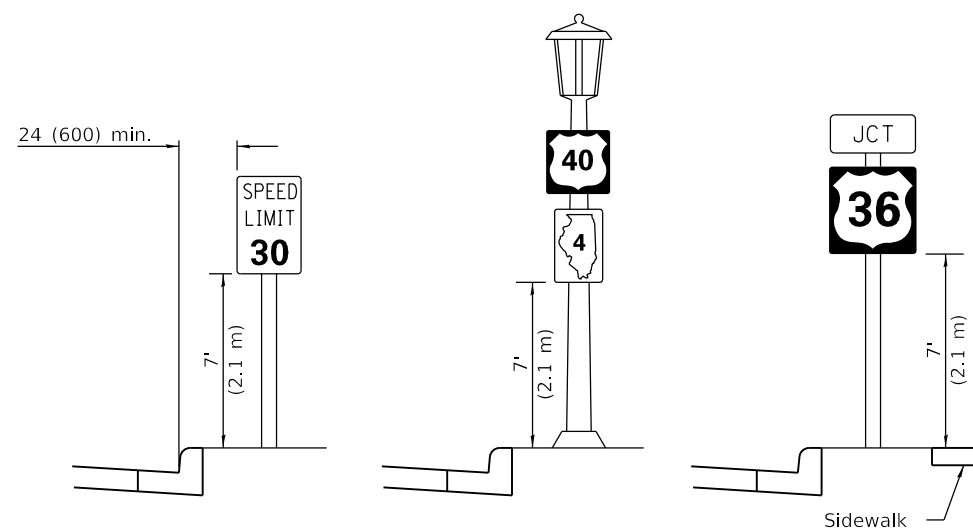

URBAN LOCATIONS

TYPICAL INSTALLATIONS

Signs in any area shall be erected to a uniform height above the edge of the pavement.

All dimensions are in inches (millimeters) unless otherwise shown.

Illinois Department of Transportation

PASSED January 1, 2014
Justin Mann
 ENGINEER OF OPERATIONS

APPROVED January 1, 2014
[Signature]
 ENGINEER OF DESIGN AND ENVIRONMENT

ISSUED 1-1-97

DATE	REVISIONS
1-1-14	Added shoulders and slopes.
	Changed sign distances from roadway and shoulder.
1-1-12	Rev. sign elev. for multilane hwy's. Revised sign elev. and dist. to curb for rural loc.

SIGN PANEL ERECTION DETAILS

STANDARD 720006-04

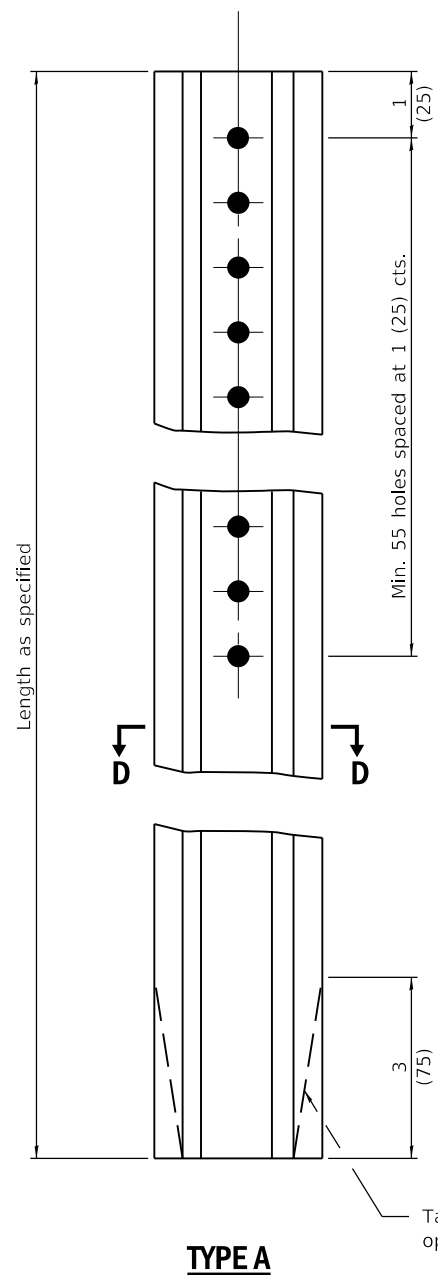

TYPE A

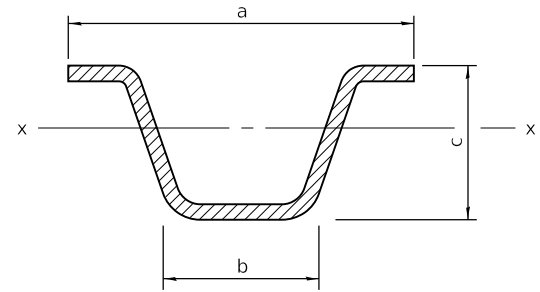

SECTION D-D

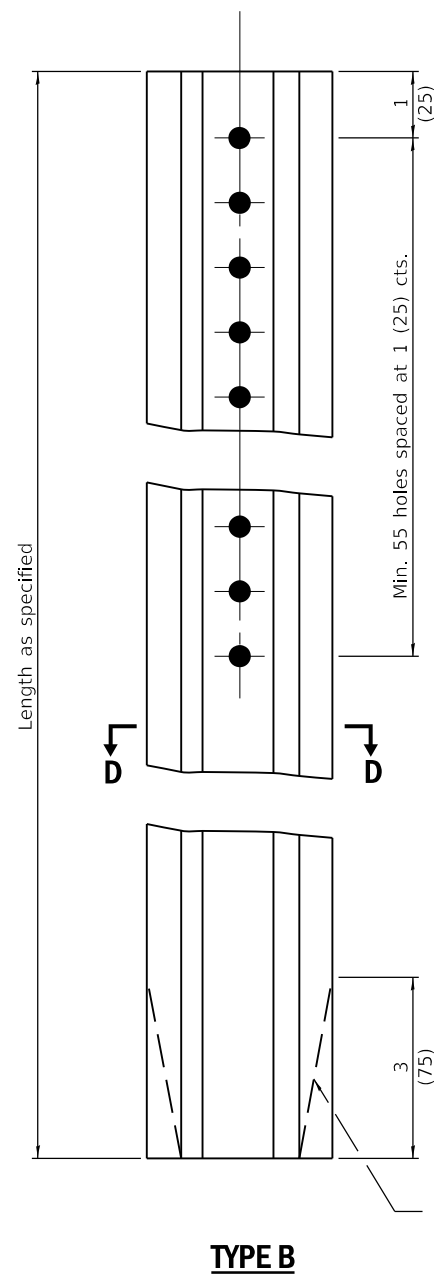

TYPE B

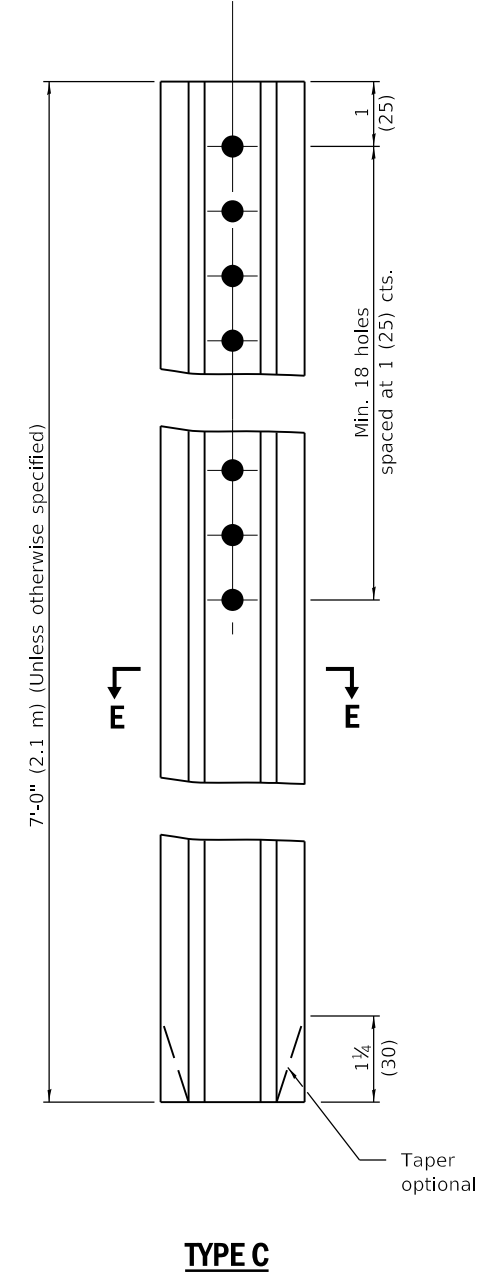

TYPE C

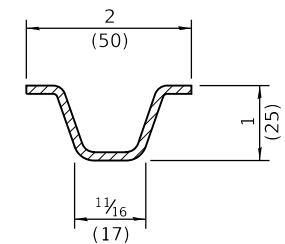

SECTION E-E

Steel - 1.12 lbs./ft. (1.67 kg/m)

		a	b	c	Sx-x in. ³ (mm ³)	lbs./ft. (kg/m)
TYPE A	Steel	3 1/16 (78)	1 1/2 (32)	1 1/16 (37)	0.223 (3,654)	2.00 (2.98)
	Aluminum	3 1/2 (89)	1 1/2 (41)	1 1/2 (48)	0.435 (7,128)	0.90 (1.34)
TYPE B	Steel	3 3/16 (81)	1 1/2 (32)	1 1/2 (38)	0.341 (5,588)	3.00 (4.46)
	Aluminum	4 3/8 (118)	2 1/2 (57)	2 3/8 (60)	0.888 (14,552)	1.30 (1.93)

GENERAL NOTES

Dimensions shown for cross sections are minimum.

All holes are 3/8 (10).

Sx-x is the minimum section modulus about the x-x axis of the post as shown. For posts in which holes are punched or drilled for more than half their length, Sx-x shall be computed for the net section.

All dimensions are in inches (millimeters) unless otherwise shown.

DATE	REVISIONS
1-1-09	Switched units to English (metric).
1-1-97	Renum. Standard 2350-4.

**METAL POSTS FOR SIGNS,
MARKERS & DELINEATORS**

STANDARD 720011-01

Illinois Department of Transportation

PASSED January 1, 2009

ENGINEER OF POLICY AND PROCEDURES

APPROVED January 1, 2009

ENGINEER OF DESIGN AND ENVIRONMENT

ISSUED 1-1-97

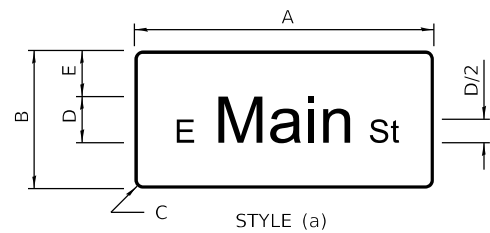

STYLE (a)

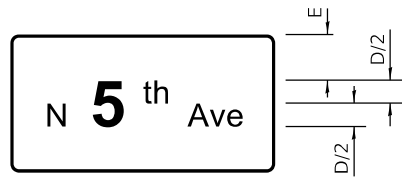

STYLE (b)



STYLE (c)



STYLE (d)



STYLE (e)



STYLE (f)

When road classification only is on the second line, it should not be abbreviated.

TYPICAL SIGN STYLES

SIGN STYLE	DIMENSIONS								LETTER SIZE UC/LC PRIMARY			BORDER
	A	B	C	D	E	F	G	H	1	2	*	
a,b,d	Var.	12 (300)	1½ (40)	6 (150)	3 (75)	-	-	-	6/4½ (150/115)	-	-	⅜ (10)
	Var.	18 (450)	1½ (40)	8 (200)	5 (125)	-	-	-	8/6 (200/150)	-	-	⅝ (15)
	Var.	24 (600)	1½ (40)	10 (250)	7 (175)	-	-	-	10/7½ (250/190)	-	-	⅝ (15)
	Var.	30 (750)	1½ (45)	12 (300)	9 (225)	-	-	-	12/9 (400/300)	-	-	¾ (20)
c,e	Var.	24 (600)	1½ (40)	6 (150)	-	-	5½ (140)	4 (100)	6/4½ (150/115)	-	3 (75)	⅝ (15)
	Var.	30 (750)	1½ (45)	8 (200)	-	-	7 (175)	4½ (115)	8/6 (200/150)	-	4 (100)	¾ (20)
	Var.	36 (900)	2¼ (60)	10 (250)	-	-	7½ (190)	6 (150)	10/7½ (250/190)	-	5 (125)	¾ (20)
	Var.	42 (1050)	3 (75)	12 (300)	-	-	8½ (215)	7 (175)	12/9 (400/300)	-	6 (150)	1 (25)
f	Var.	24 (600)	1½ (40)	6 (150)	4 (100)	4 (100)	-	-	6/4½ (150/115)	6/4½ (150/115)	-	⅝ (15)
	Var.	30 (750)	1½ (45)	8 (200)	4½ (115)	5 (125)	-	-	8/6 (200/150)	8/6 (200/150)	-	¾ (20)
	Var.	42 (1050)	3 (75)	10 (250)	7½ (190)	7 (175)	-	-	10/7½ (250/190)	10/7½ (250/190)	-	1 (25)
	Var.	48 (1200)	3 (75)	12 (300)	7½ (190)	8 (200)	-	-	12/9 (400/300)	12/9 (400/300)	-	1 (25)

* Supplemental Messages

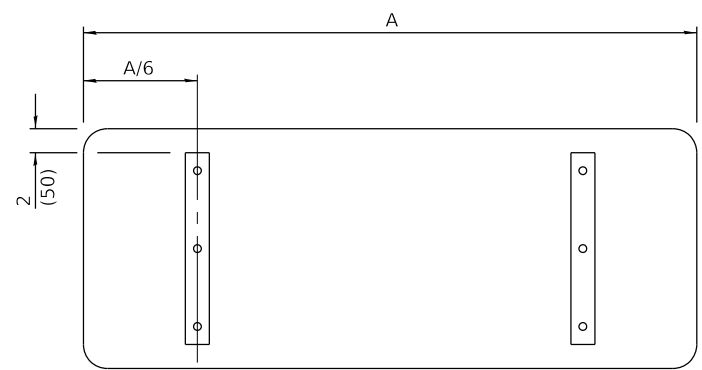

SUPPORTING CHANNELS

8' (2.4 m) max. for mastarms 16' (4.9 m) through 55' (16.8 m), 18' (5.5 m) max. for mastarms 56' (17.1 m) through 75' (22.9 m) to mid-point of sign panel or blankout sign.

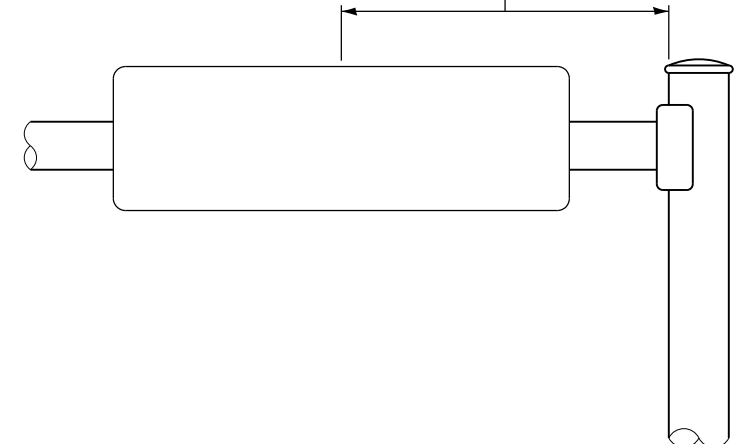

MOUNTING LOCATION

GENERAL NOTES

All signs shall have a white reflectorized legend and border on a green reflectorized background.
The sign panels shall be mounted as shown on Standard 720001 or as specified in the plans.
All dimensions are in inches (millimeters) unless otherwise shown.

DATE	REVISIONS
1-1-18	Revised MOUNTING LOCATION detail.
1-1-12	Revised table and lettering to upper/lower case per current MUTCD.

MAST ARM MOUNTED STREET NAME SIGNS

STANDARD 720016-04

Illinois Department of Transportation

PASSED January 1, 2018
Amy Allen
 ENGINEER OF OPERATIONS

APPROVED January 1, 2018
[Signature]
 ENGINEER OF DESIGN AND ENVIRONMENT

ISSUED 1-1-97

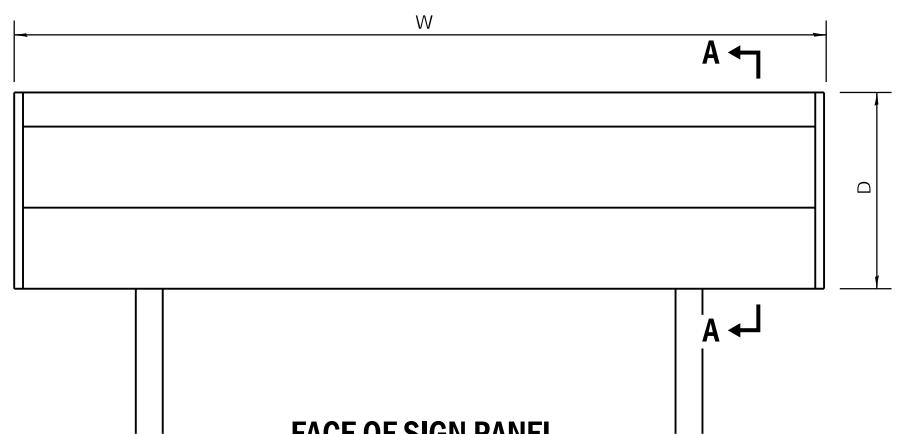

FACE OF SIGN PANEL

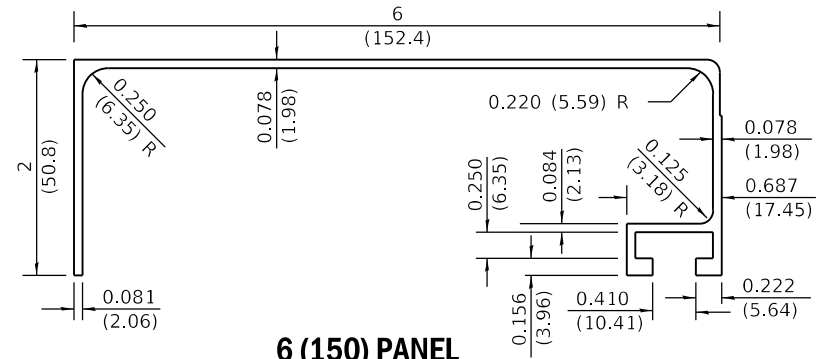

6 (150) PANEL

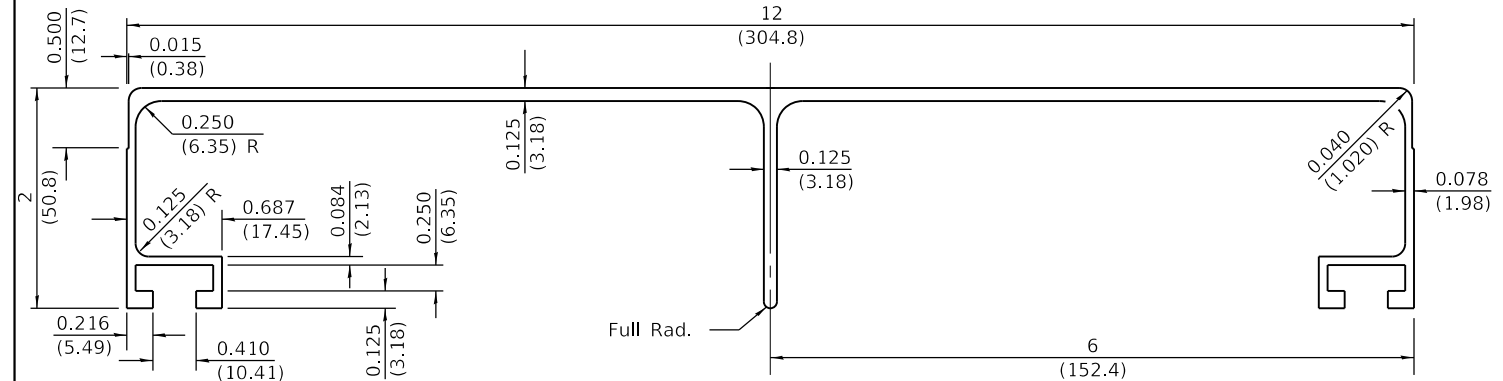

TYPE B SIGN PANEL

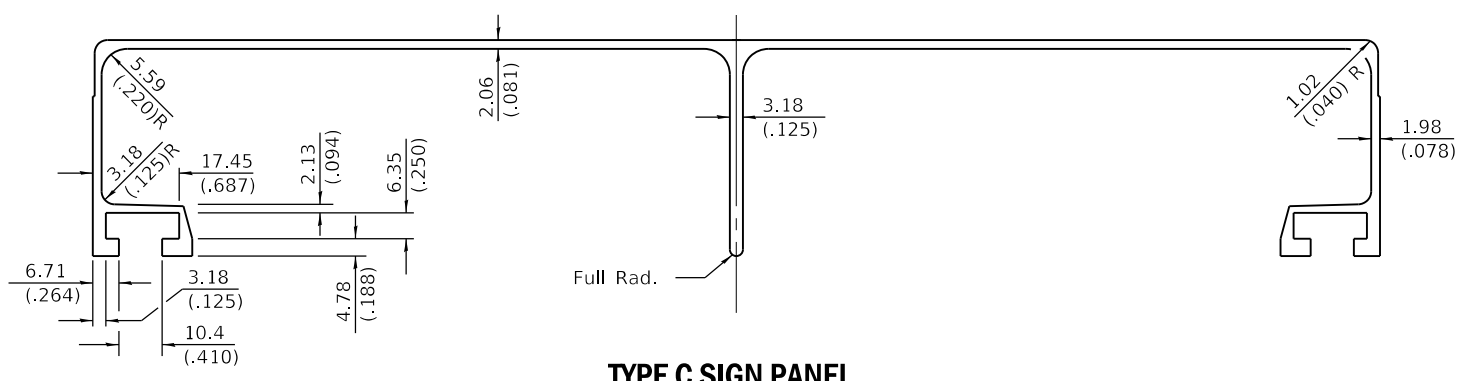

TYPE C SIGN PANEL

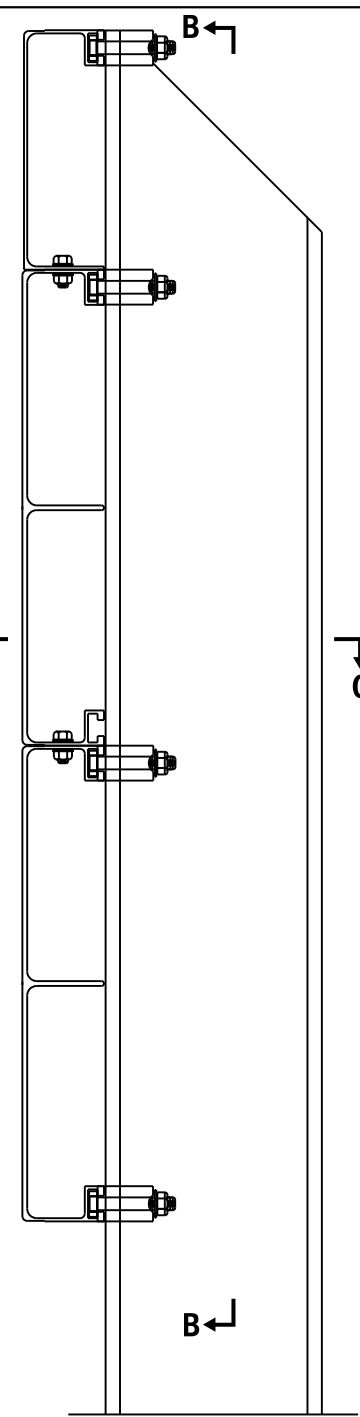

SECTION A-A



SECTION B-B

(Provide two post clips top and bottom. Alternate at interior panel joints on ground-mounted signs, and provide two clips at all panel joints on over-head mounted signs.)

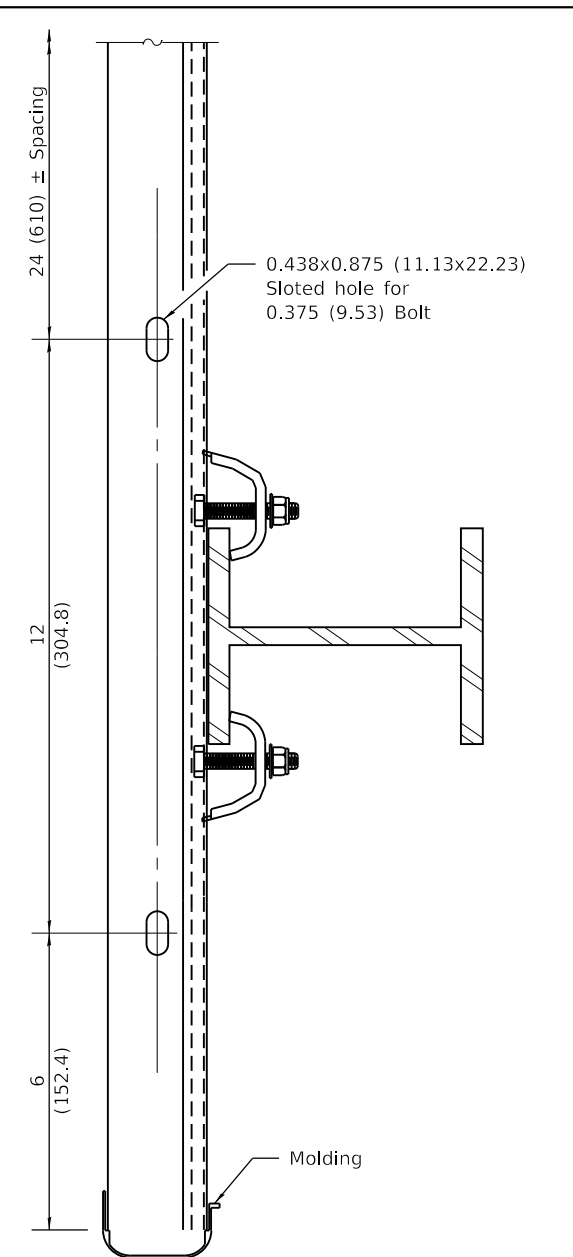

SECTION C-C
(w/o panel bolts)

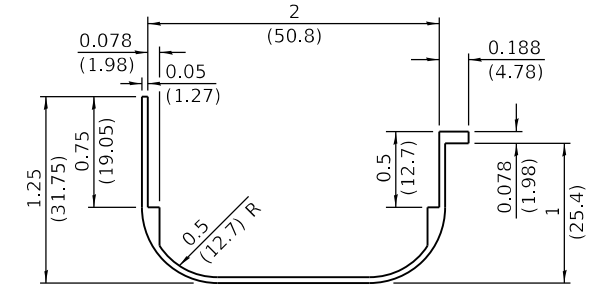

SIGN MOLDING

(Color shall match sign face material. To be riveted to sign panel at 24 (600) O.C.)
All dimensions are in inches (millimeters) unless otherwise shown.

Illinois Department of Transportation

PASSED January 1, 2022
Amy Allen
ENGINEER OF OPERATIONS

APPROVED January 1, 2022
John Doe
ENGINEER OF DESIGN AND ENVIRONMENT

00-1-1 03/05/11

DATE	REVISIONS
1-1-22	Removed stainless steel clip option and minor typos.
1-1-09	Added aluminium clip. Switched units to English (metric).

SIGN PANELS
EXTRUDED ALUMINUM TYPE
(Sheet 1 of 2)
STANDARD 720021-03

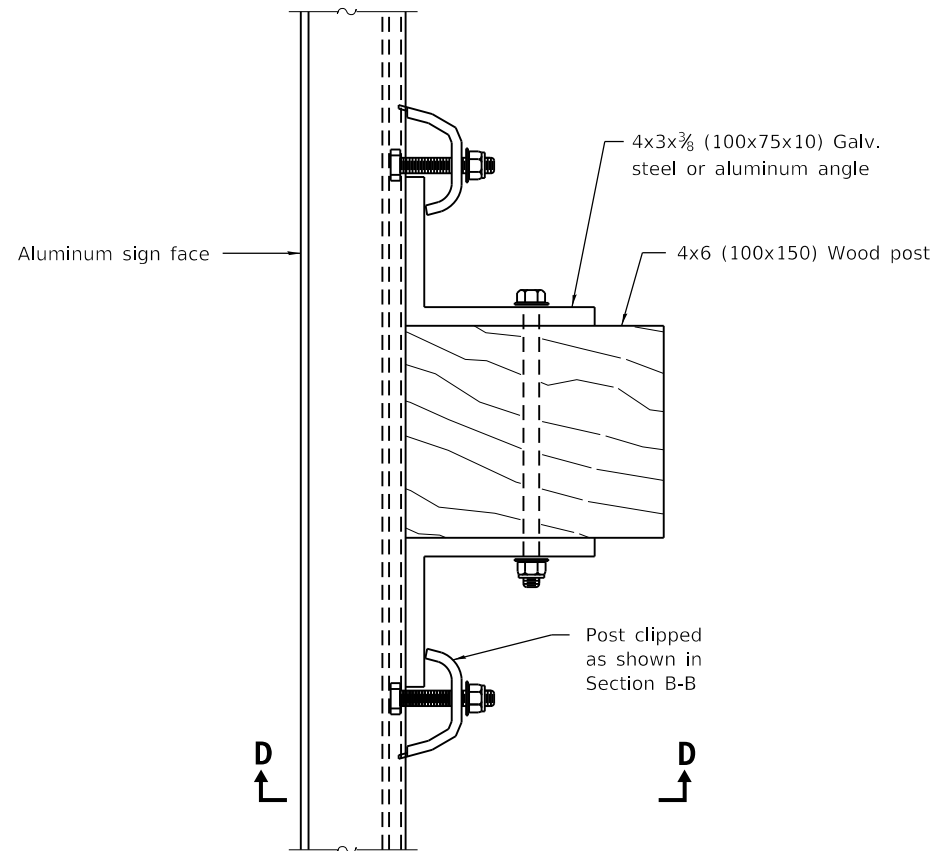

SIGN PANEL ATTACHMENT TO WOOD POST

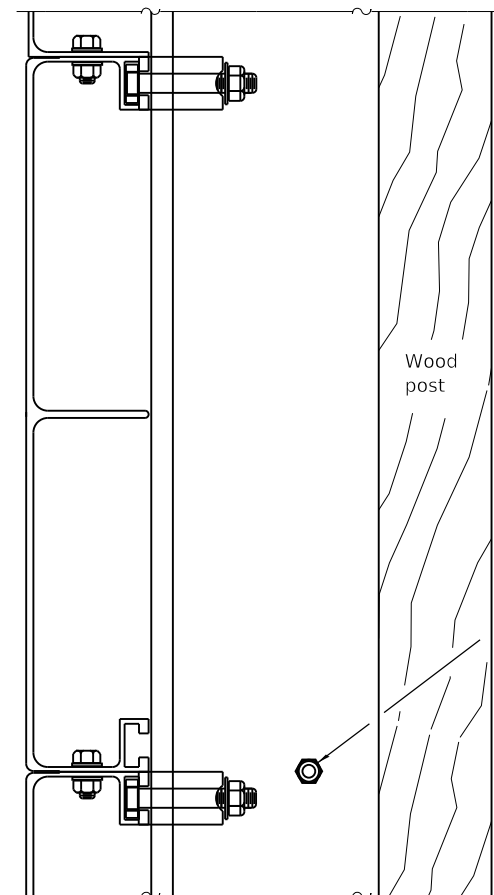

SECTION D-D

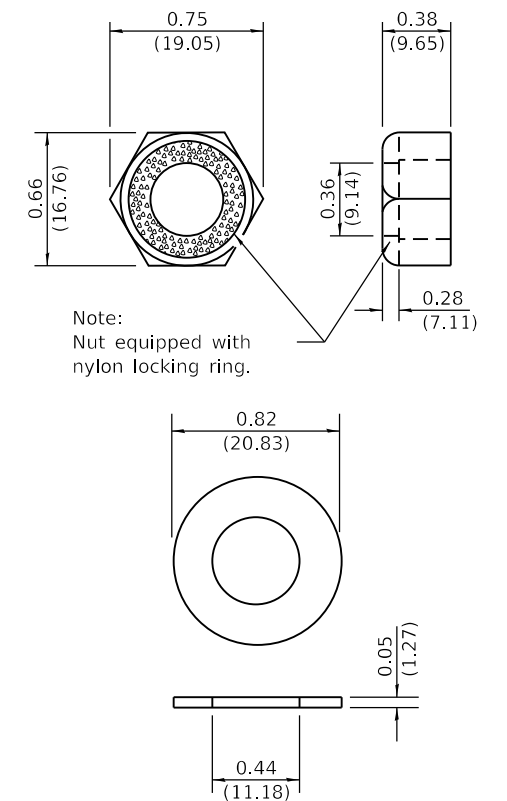
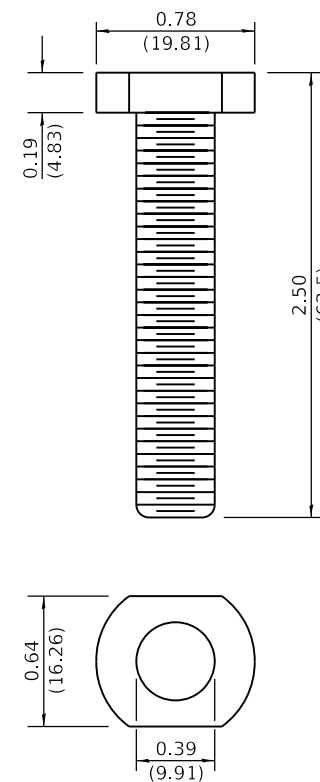

ALUMINUM CLIP NUT, BOLT AND WASHER ASSEMBLY

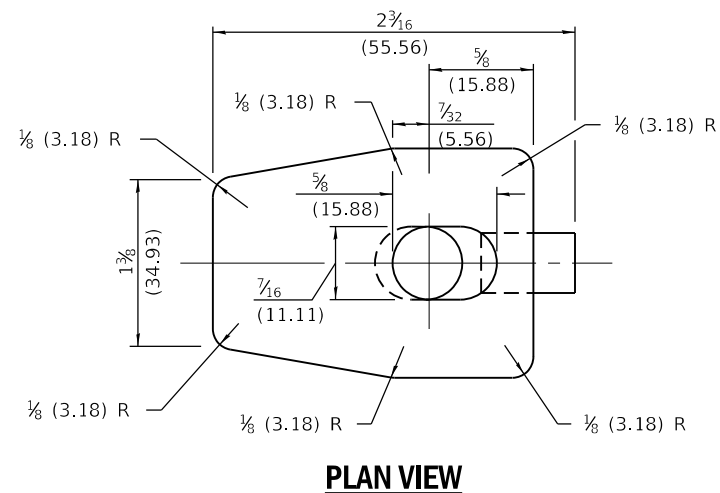

PLAN VIEW

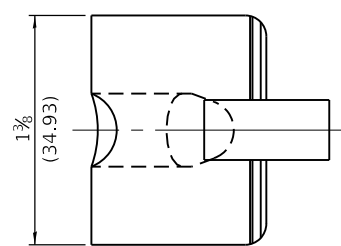

END VIEW

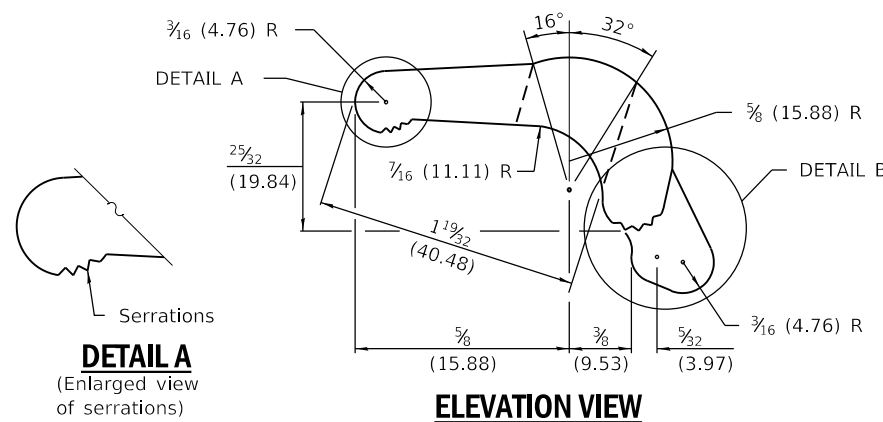

ELEVATION VIEW

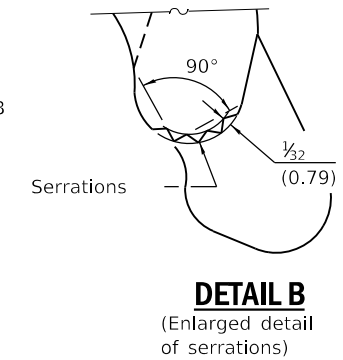
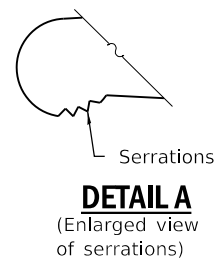

ALUMINUM CLIP

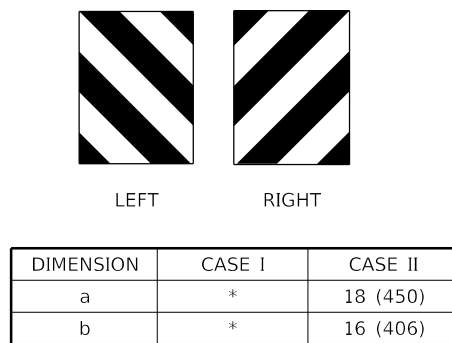
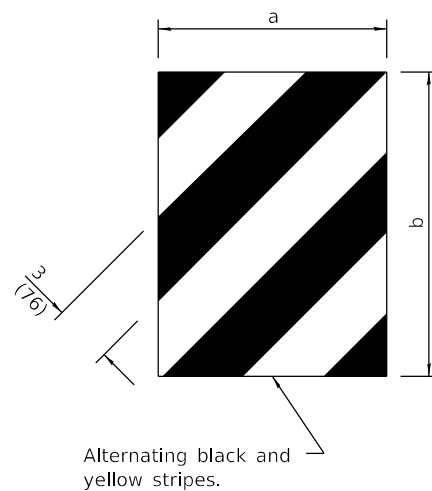
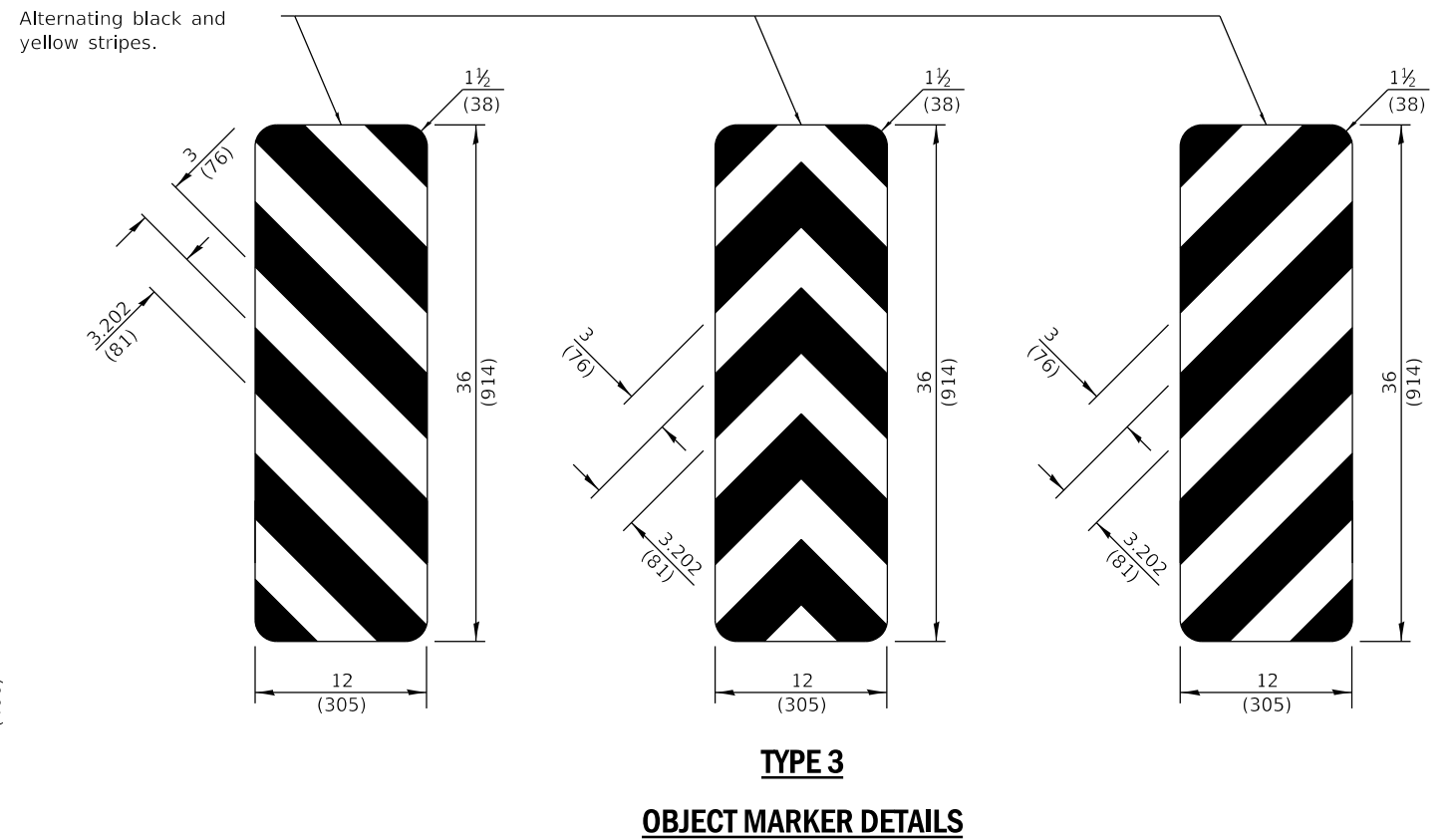
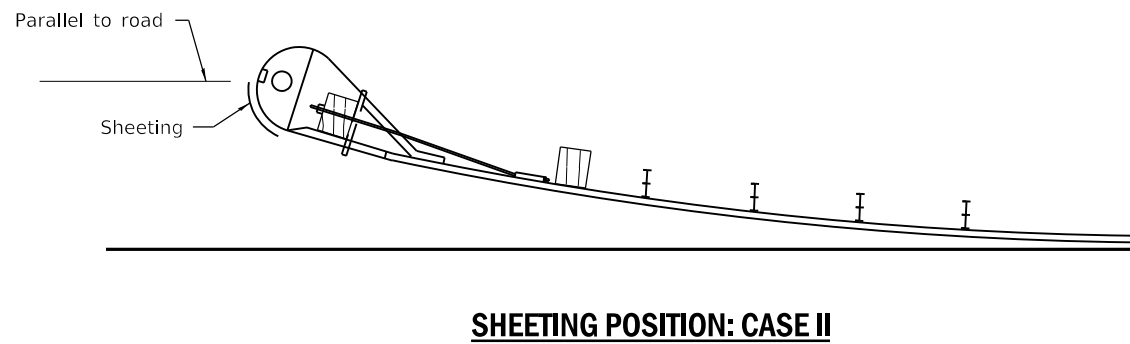
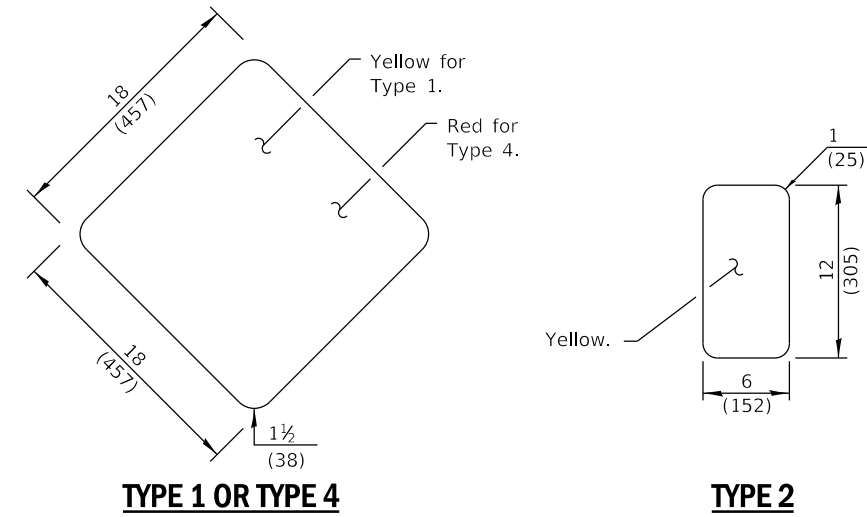
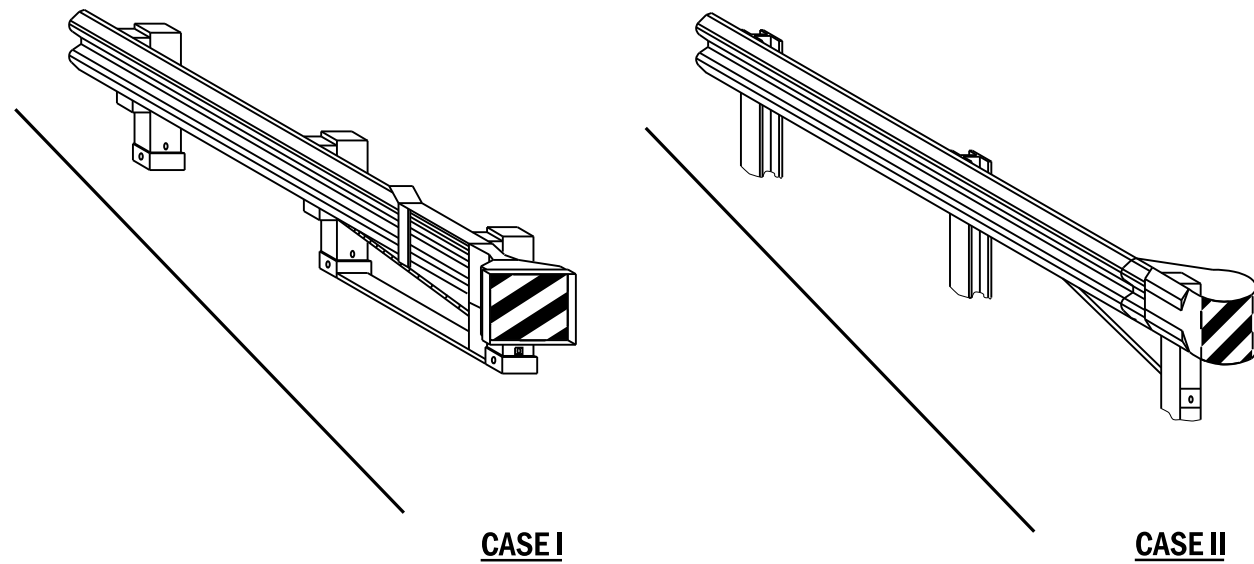

DIRECT APPLIED

TERMINAL MARKER DETAILS

Color: Black / Yellow reflectorized

* The width and height (a, b) of the terminal marker shall be within approximately 1 (25) of the outer edge of the terminal end.

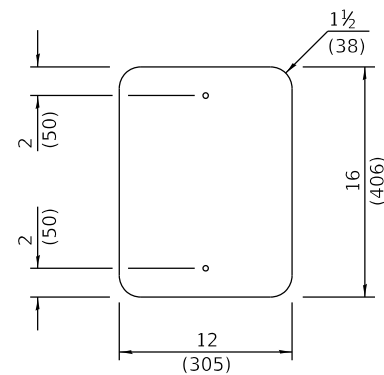

GENERAL NOTES

See detail on Standard 729001 for mounting markers to posts.

All dimensions are in inches (millimeters) unless otherwise shown.

DATE	REVISIONS
1-1-17	Omitted minimum reflective area requirement for terminal marker.
4-1-16	Renumbered standard from 635006.

OBJECT AND TERMINAL MARKERS

STANDARD 725001-01

Illinois Department of Transportation

PASSED January 1, 2017

ENGINEER OF OPERATIONS

APPROVED January 1, 2017

ENGINEER OF DESIGN AND ENVIRONMENT

ISSUED 1-1-2016

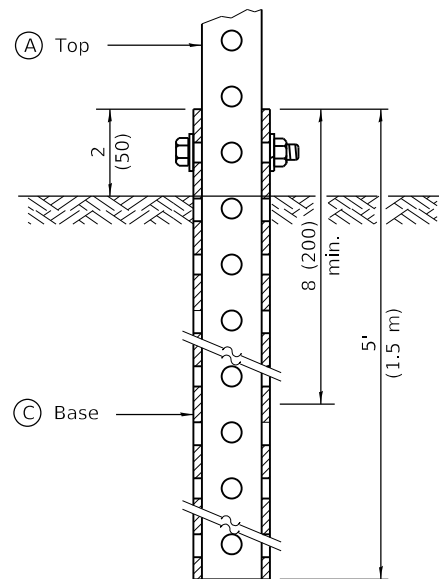

GROUND MOUNT DETAIL

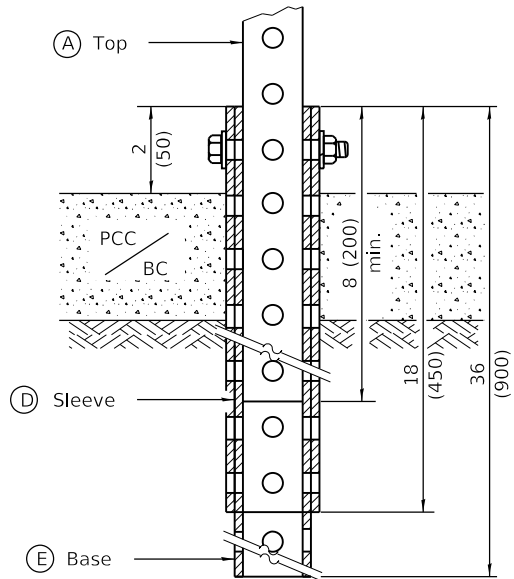

PAVEMENT MOUNT DETAIL

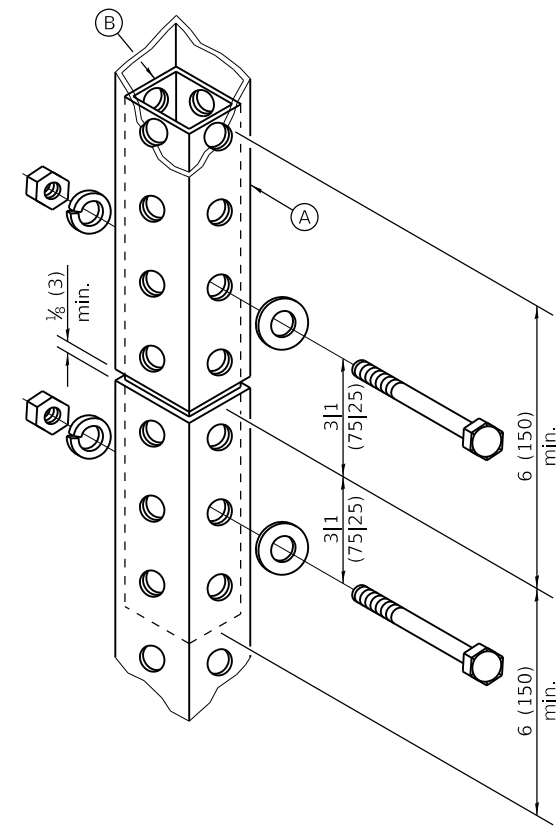

SPLICE DETAIL

(A)	2 x 2 x var. (51 x 51 var.)
(B)	1 3/4 x 1 3/4 x 12 (44 x 44 x 300)
(C)	2 1/4 x 2 1/4 x 60 (57 x 57 x 1500)
(D)	2 1/2 x 2 1/2 x 18 (64 x 64 x 450)
(E)	2 1/4 x 2 1/4 x 36 (57 x 57 x 900)

GENERAL NOTES

All bolts 3/8" (M10) hex head zinc or cadmium plated.

All dimensions are in inches (millimeters) unless otherwise shown.

DATE	REVISIONS
1-1-09	Switched units to English (metric).
1-1-07	New Standard. Used to be part of Standard 720006.

TELESCOPING STEEL SIGN SUPPORT

STANDARD 728001-01

Illinois Department of Transportation

PASSED January 1, 2009

ENGINEER OF OPERATIONS

APPROVED January 1, 2009

ENGINEER OF DESIGN AND ENVIRONMENT

ISSUED 1-1-07

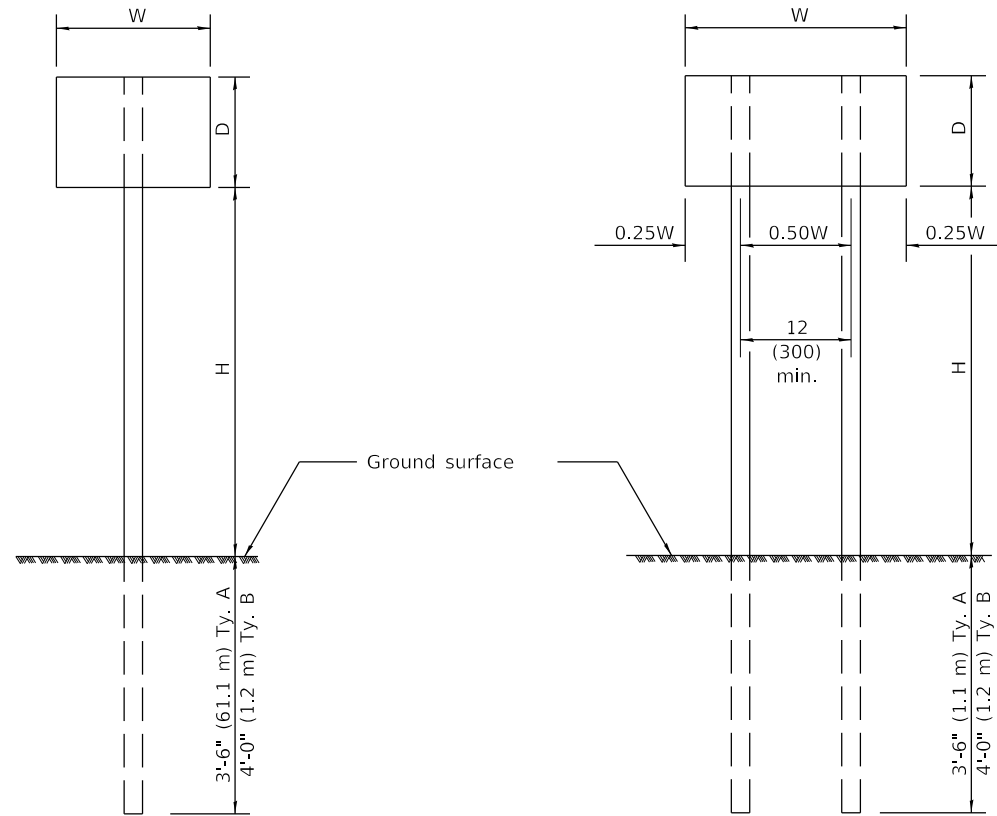

ONE POST INSTALLATION

TWO POST INSTALLATION

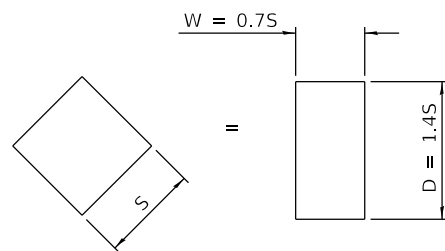

For diamond shaped sign with side S as shown, use required post size for a sign with $W = 0.7S$ and $D = 1.4S$.

SIGN DEPTH (D)	H	NO. AND TYPE OF POST FOR SIGN WIDTH (W)				
		12 (300)	18 (450)	24 (600)	30 (750)	36 (900)
18 (450)	5'-0" (1.5 m)	A	A	A	A	A
	5'-6" (1.7 m)	A	A	A	A	A
	6'-0" (1.8 m)	A	A	A	A	B
	6'-6" (2.0 m)	A	A	A	A	B
	7'-0" (2.1 m)	A	A	A	A	B
	7'-6" (2.3 m)	A	A	A	A	B
	8'-0" (2.4 m)	A	A	A	A	B
	9'-0" (2.7 m)	A	A	A	B	B
24 (600)	5'-0" (1.5 m)	A	A	A	A	B
	5'-6" (1.7 m)	A	A	A	A	B
	6'-0" (1.8 m)	A	A	A	B	B
	6'-6" (2.0 m)	A	A	A	B	B
	7'-0" (2.1 m)	A	A	A	B	B
	7'-6" (2.3 m)	A	A	A	B	B
	8'-0" (2.4 m)	A	A	A	B	2A
	9'-0" (2.7 m)	A	A	B	B	2A
30 (750)	5'-0" (1.5 m)	A	A	A	B	B
	5'-6" (1.7 m)	A	A	A	B	2A
	6'-0" (1.8 m)	A	A	A	B	2A
	6'-6" (2.0 m)	A	A	A	B	2A
	7'-0" (2.1 m)	A	A	B	B	2A
	7'-6" (2.3 m)	A	A	B	B	2A
	8'-0" (2.4 m)	A	A	B	B	2A
	9'-0" (2.7 m)	A	A	B	2A	2A
36 (900)	5'-0" (1.5 m)	A	A	B	B	2A
	5'-6" (1.7 m)	A	A	B	B	2A
	6'-0" (1.8 m)	A	A	B	B	2A
	6'-6" (2.0 m)	A	A	B	2A	2A
	7'-0" (2.1 m)	A	A	B	2A	2A
	7'-6" (2.3 m)	A	A	B	2A	2A
	8'-0" (2.4 m)	A	B	B	2A	2A
	9'-0" (2.7 m)	A	B	B	2A	2B
4'-0" (1.2 m)	5'-0" (1.5 m)	A	A	B	2A	2A
	5'-6" (1.7 m)	A	B	B	2A	2A
	6'-0" (1.8 m)	A	B	B	2A	2A
	6'-6" (2.0 m)	A	B	2A	2A	2B
	7'-0" (2.1 m)	A	B	2A	2A	2B
	7'-6" (2.3 m)	A	B	2A	2B	2B
	8'-0" (2.4 m)	A	B	2A	2B	2B
	9'-0" (2.7 m)	B	2A	2B	2B	2B

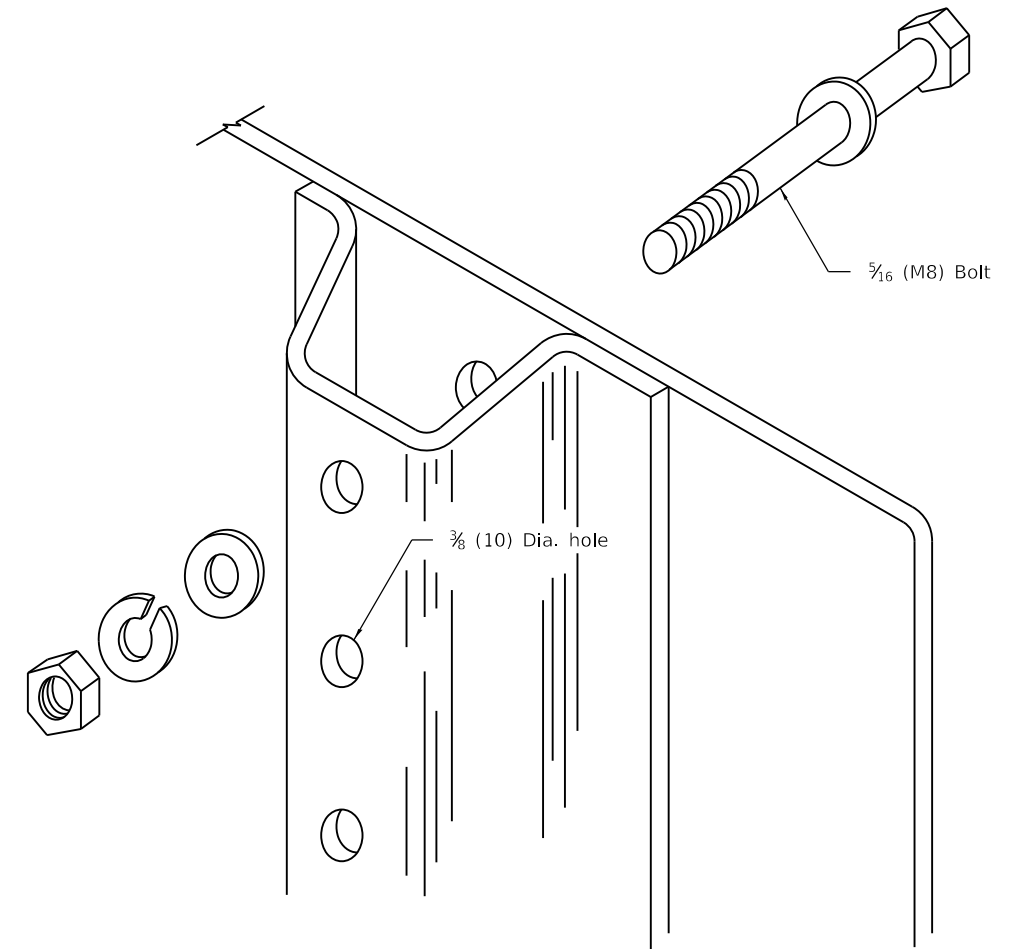

DETAIL OF MOUNTING SIGN TO POST

NOTE: Minimum of 2 bolts per post required.

GENERAL NOTES

DESIGN: Current AASHTO Standard Specifications for Structural Supports for Highway Signs, Luminaires and Traffic Signals.

LOADING: for 60 mph (95 km/h) wind velocity with 30% gust factor, normal to sign.

SOIL PRESSURE: Minimum allowable soil pressure 1.25 tsf (120 kPa).

See Standard 720011 for details of Types A and B posts.

All dimensions are in inches (millimeters) unless otherwise shown.

DATE	REVISIONS
1-1-09	Switched units to English (metric).
1-1-97	Renum. Standard 2363-2.

APPLICATIONS OF TYPES A & B METAL POSTS (FOR SIGNS & MARKERS)

STANDARD 729001-01

Illinois Department of Transportation

PASSED January 1, 2009

ENGINEER OF POLICY AND PROCEDURES

APPROVED January 1, 2009

ENGINEER OF DESIGN AND ENVIRONMENT

ISSUED 1-1-97

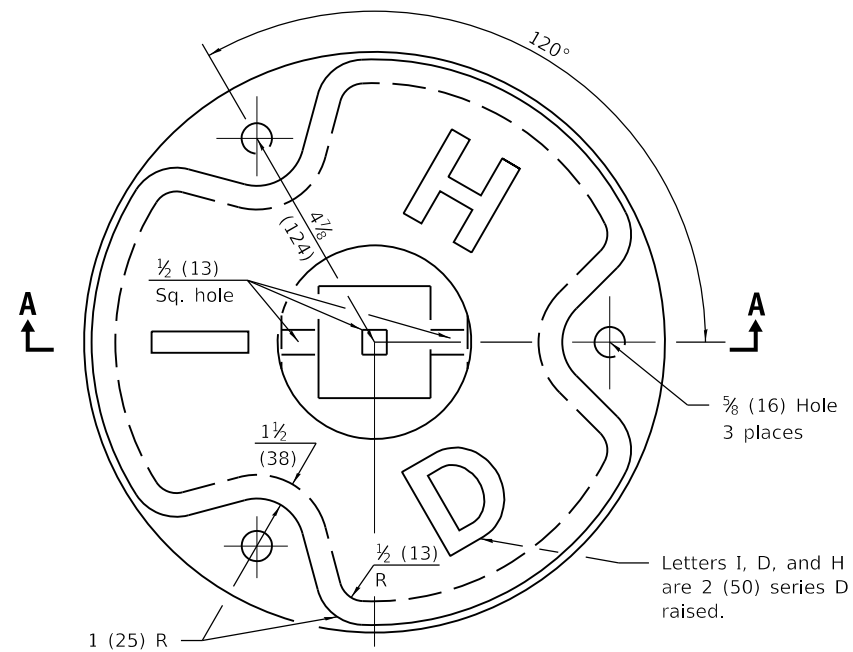

PLAN

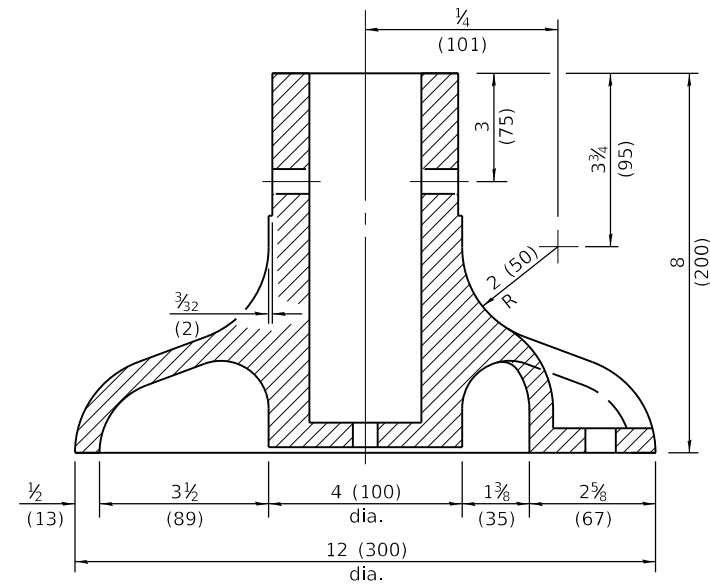

SECTION A-A

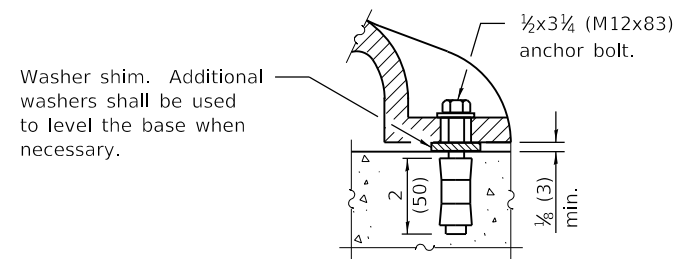

ANCHOR BOLT DETAIL

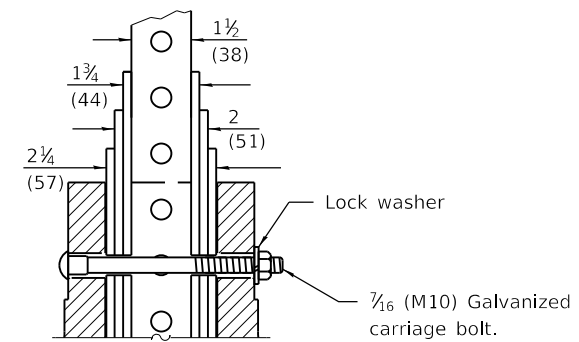

POST ASSEMBLY DETAIL

All dimensions are in inches (millimeters) unless otherwise shown.

Illinois Department of Transportation

PASSED January 1, 2009

ENGINEER OF OPERATIONS

APPROVED January 1, 2009

ENGINEER OF DESIGN AND ENVIRONMENT

ISSUED 1-1-07

DATE	REVISIONS
1-1-09	Switched units to English (metric).
1-1-07	New Standard. Used to be part of Standard 720006.

BASE FOR TELESCOPING STEEL SIGN SUPPORT

STANDARD 731001-01

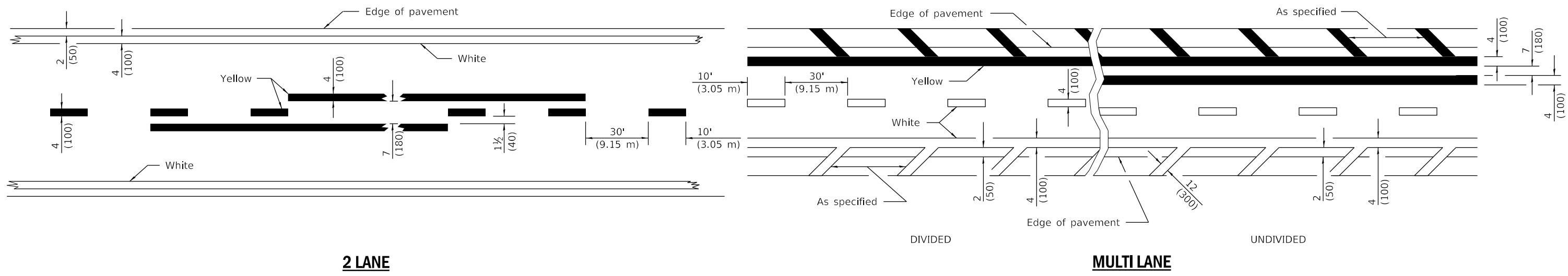

2 LANE

MULTI LANE

LANE AND EDGE LINES

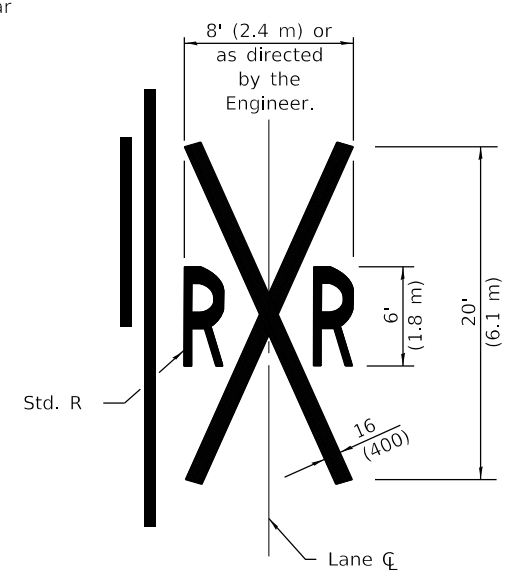
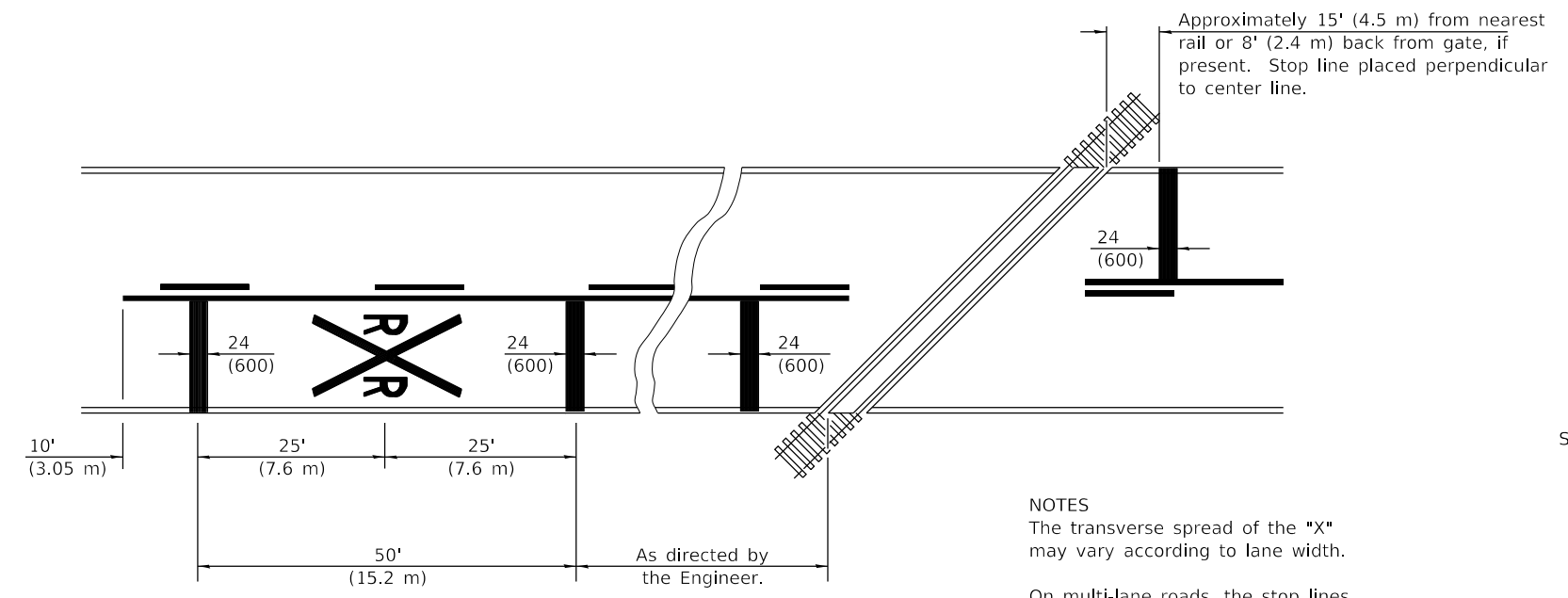

NOTES

The transverse spread of the "X" may vary according to lane width.

On multi-lane roads, the stop lines shall extend across all approach lanes and separate RXR symbols shall be placed adjacent to each other in each lane.

When the pavement marking symbol is used, a portion of the symbol should be located directly adjacent to the Advance Warning Sign (W10-1) as placed by Table 2C-4, Condition B of the MUTCD.

PAVEMENT MARKINGS AT RAILROAD-HIGHWAY GRADE CROSSING

All dimensions are in inches (millimeters) unless otherwise shown.

DATE	REVISIONS
1-1-15	Added symbols. Revised bike symbol. Revised note for stop line at RR crossing.
1-1-14	Added bike symbol. Renamed 'LANE DROP ARROW' detail to 'LANE-REDUCTION ARROW'.

TYPICAL PAVEMENT MARKINGS

(Sheet 1 of 3)

STANDARD 780001-05

Illinois Department of Transportation

PASSED January 1, 2015
Amy Allen
 ENGINEER OF OPERATIONS

APPROVED January 1, 2015
[Signature]
 ENGINEER OF DESIGN AND ENVIRONMENT

ISSUED 1-1-97

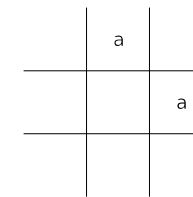
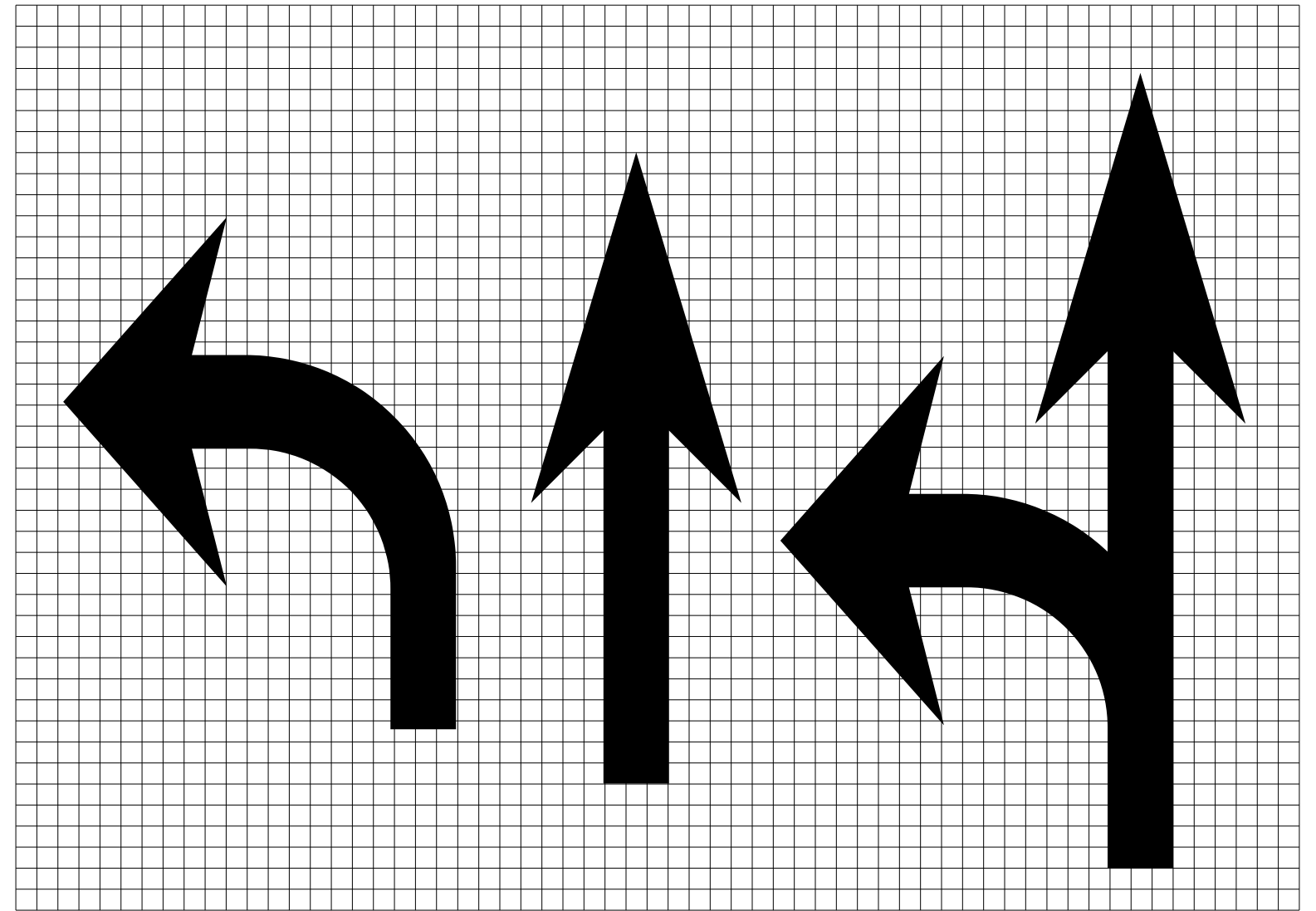

Legend Height	Arrow Size	a
6' (1.8 m)	Small	2.9 (74)
8' (2.4 m)	Large	3.8 (96)

The space between adjacent letters or numerals should be approximately 3 (75) for 6' (1.8 m) legend and 4 (100) for 8' (2.4 m) legend.

LETTER AND ARROW GRID SCALE

 Illinois Department of Transportation
 PASSED January 1, 2015
Amy Eller
 ENGINEER OF OPERATIONS
 APPROVED January 1, 2015
RE
 ENGINEER OF DESIGN AND ENVIRONMENT
 ISSUED 1-1-97

TYPICAL PAVEMENT MARKINGS
 (Sheet 2 of 3)
STANDARD 780001-05

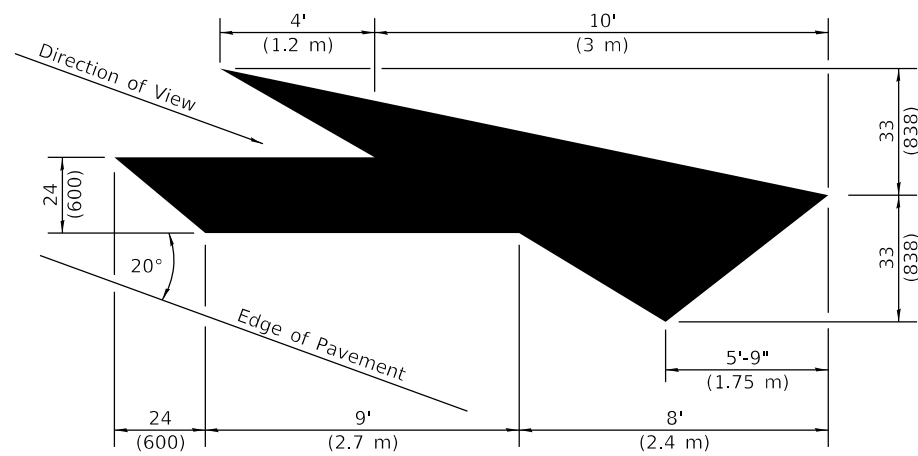

LANE-REDUCTION ARROW

Right lane-reduction arrow shown.
Use mirror image for left lane.

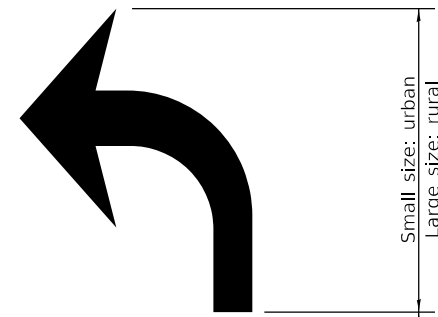

20' (6 m): urban
50' (15 m): rural
(Between arrow
and word or
between words)



WORD AND ARROW LAYOUT

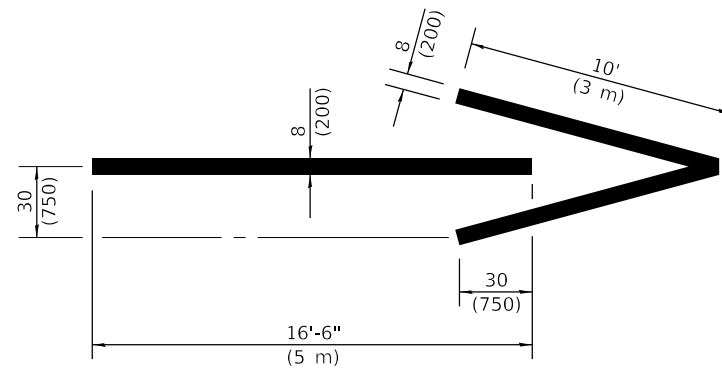

WRONG WAY ARROW

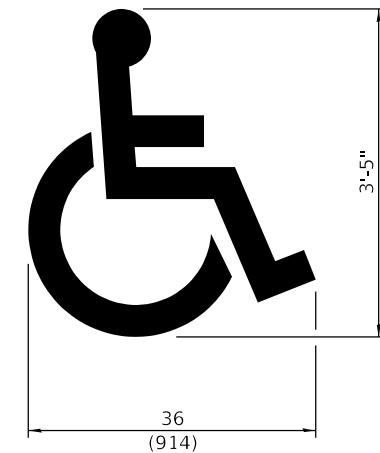

**INTERNATIONAL
SYMBOL OF
ACCESSIBILITY**

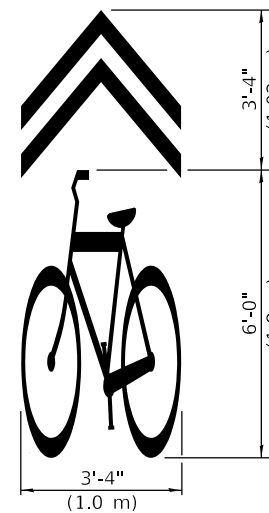

**SHARED LANE
SYMBOL**

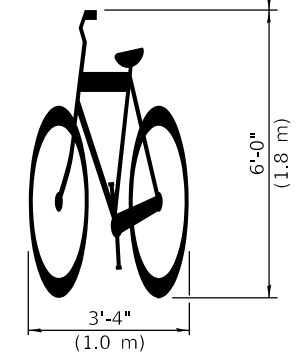
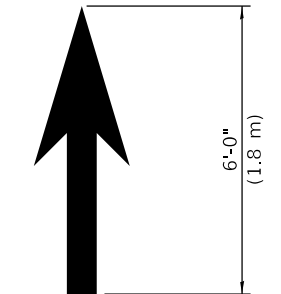

BIKE SYMBOL
(Arrow is optional.)

Illinois Department of Transportation

PASSED January 1, 2015
Amy Allen
 ENGINEER OF OPERATIONS

APPROVED January 1, 2015
[Signature]
 ENGINEER OF DESIGN AND ENVIRONMENT

ISSUED 1-1-97

**TYPICAL PAVEMENT
MARKINGS**

(Sheet 3 of 3)

STANDARD 780001-05

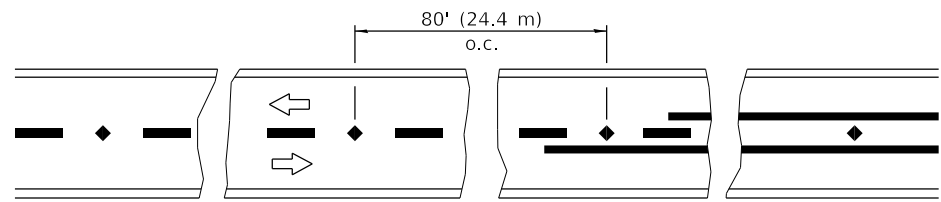

Reduce to 40' (12.2 m) o.c. on curves with posted or advisory speeds of 45 mph (70 km/h) or less.

TWO-LANE / TWO-WAY

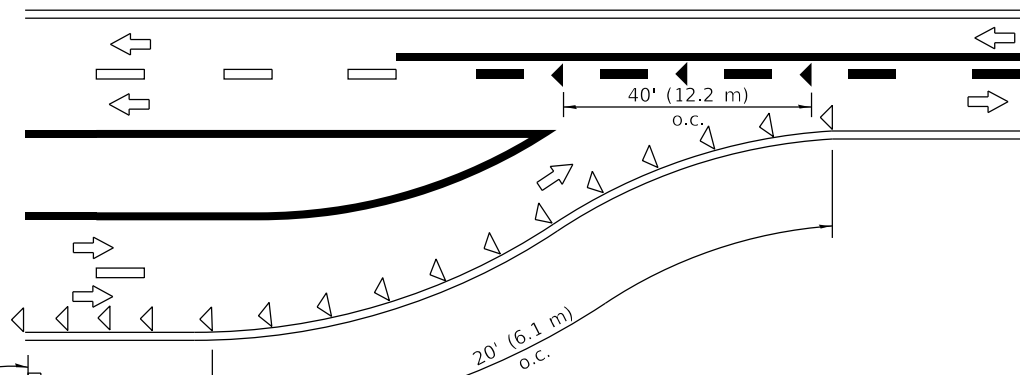

W4-2

LANE REDUCTION TRANSITION

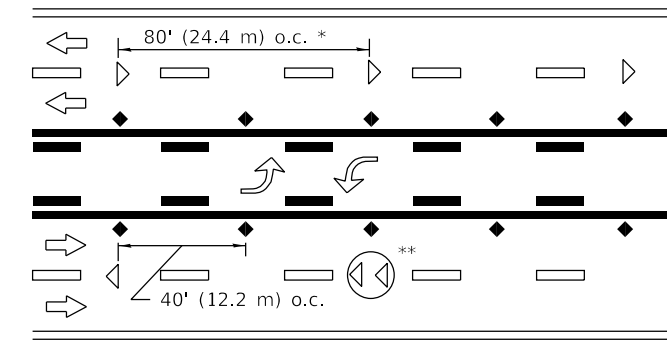

*,** See MULTI LANE DIVIDED detail for lane marker notes.

TWO-WAY LEFT TURN

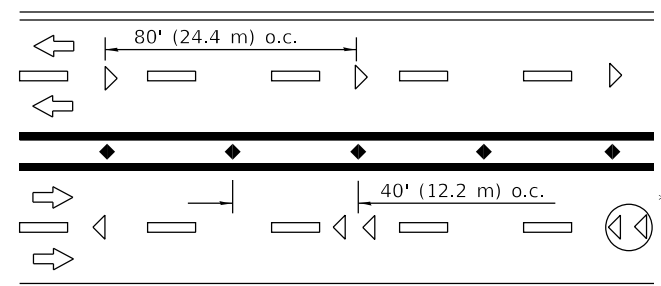

*,** See MULTI LANE DIVIDED detail for lane marker notes.

MULTI-LANE UNDIVIDED

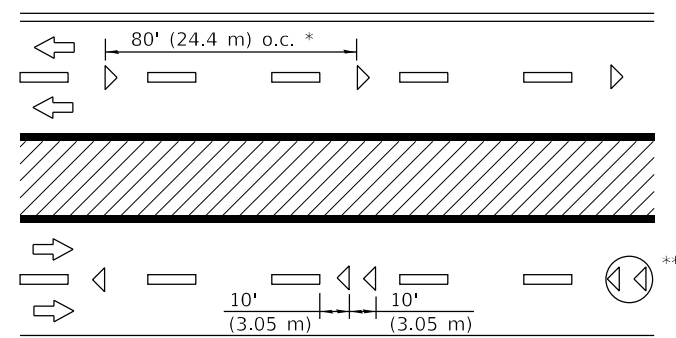

* Reduce to 40' (12.2 m) o.c. on curves where advisory speeds are 10 mph (15 km/h) lower than posted speeds.

** Where double lane line markers are specified, they shall be spaced as shown.

MULTI-LANE DIVIDED

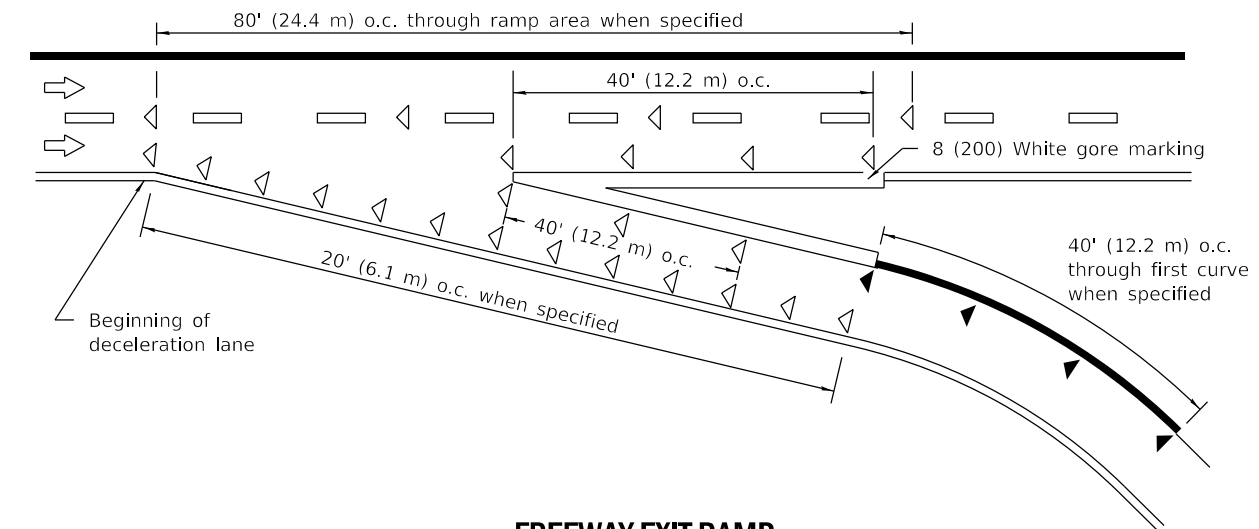

FREEWAY EXIT RAMP

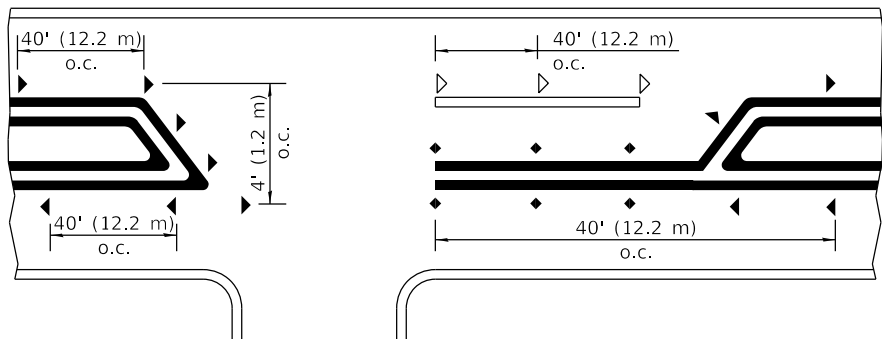
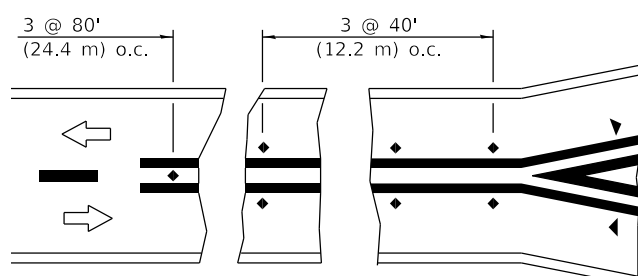

RURAL LEFT TURN

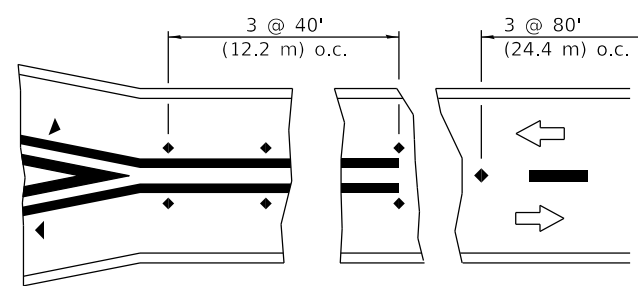

SYMBOLS

- Yellow stripe
- White stripe
- One-way amber marker
- One-way crystal marker
- Two-way amber marker

All dimensions are in inches (millimeters) unless otherwise shown.

Illinois Department of Transportation

PASSED April 1, 2016
Amy Eller
 ENGINEER OF OPERATIONS

APPROVED April 1, 2016
[Signature]
 ENGINEER OF DESIGN AND ENVIRONMENT

ISSUED 1-1-97

DATE	REVISIONS
4-1-16	Revised LANE ENDS sign
	W4-2 to agree with current MUTCD.
1-1-09	Switched units to English (metric).

**TYPICAL APPLICATIONS
 RAISED REFLECTIVE
 PAVEMENT MARKERS**

STANDARD 781001-04

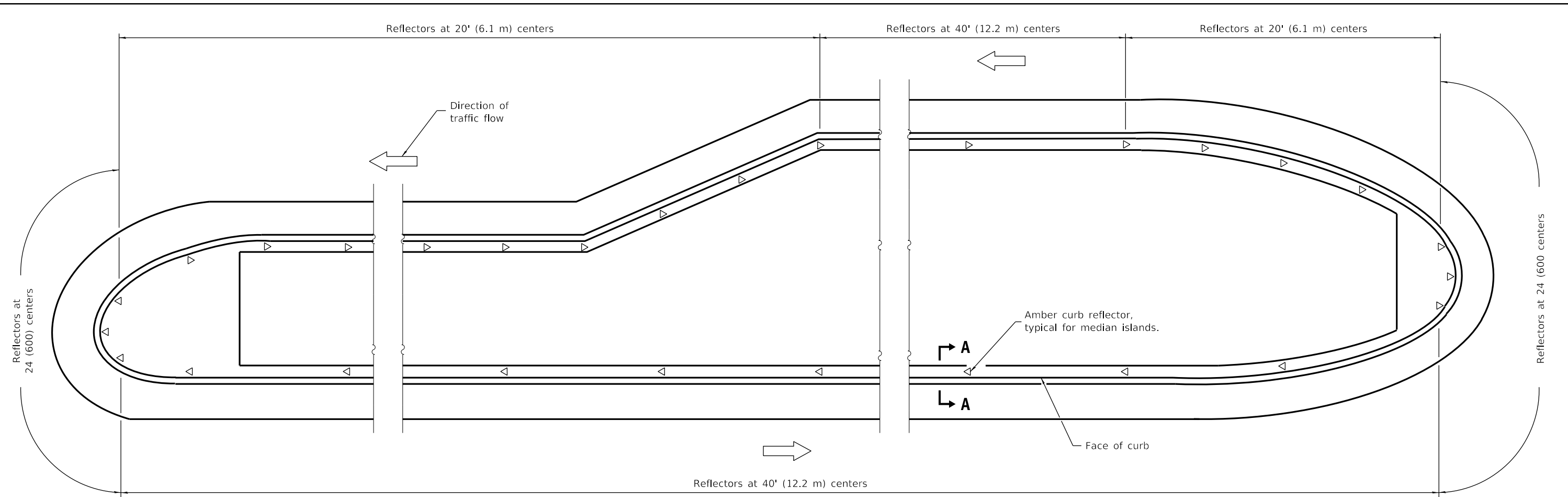

MEDIAN ISLAND

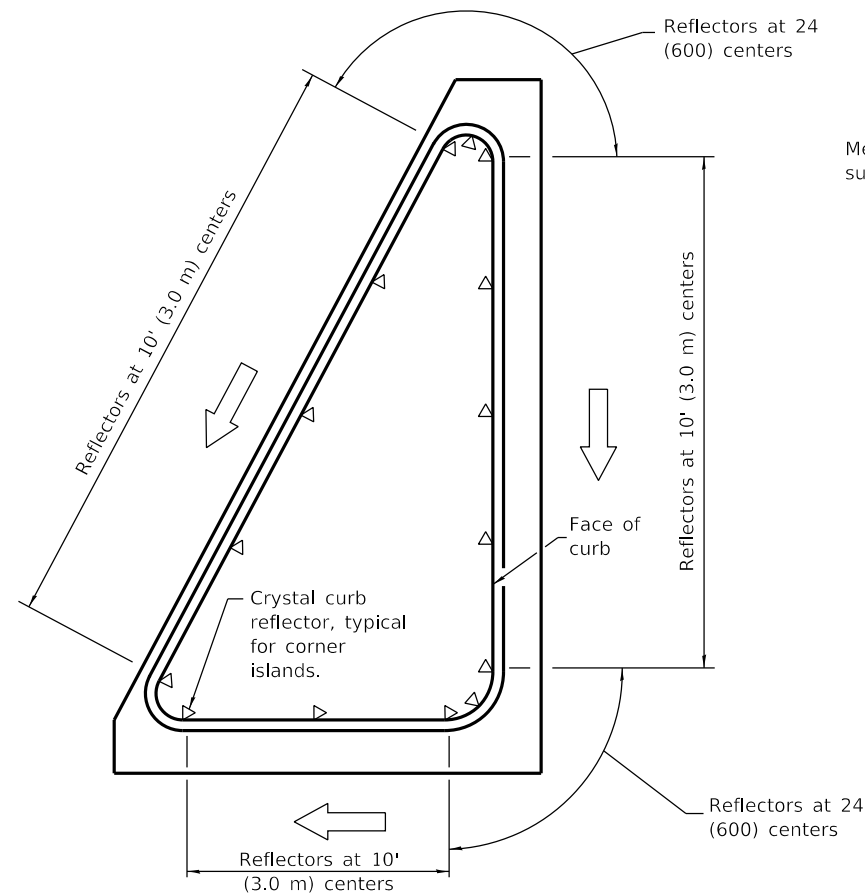

CORNER ISLAND

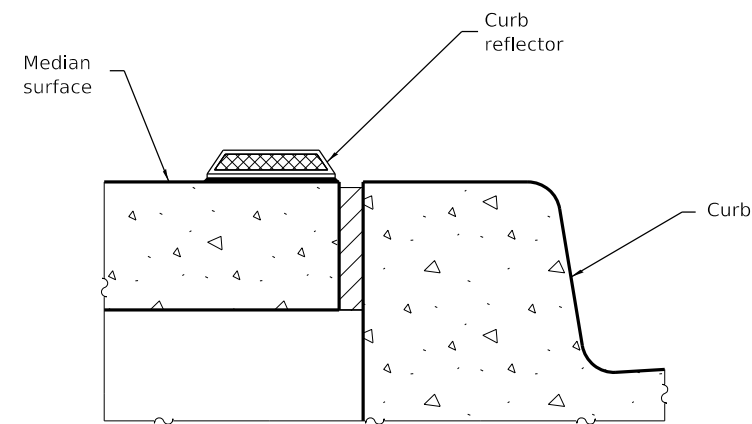

SECTION A-A
(Similar for corner islands.)

GENERAL NOTES

Curb reflectors shall be monodirectional and oriented with the reflective face toward approaching traffic.

All dimensions are in inches (millimeters) unless otherwise shown.

DATE	REVISIONS
4-1-16	Revised title and removed work 'prismatic'.
1-1-12	New standard.

CURB REFLECTORS

STANDARD 782001-01

Illinois Department of Transportation

PASSED April 1, 2016

Amy Eller
ENGINEER OF OPERATIONS

APPROVED April 1, 2016

[Signature]
ENGINEER OF DESIGN AND ENVIRONMENT

ISSUED 1-1-97

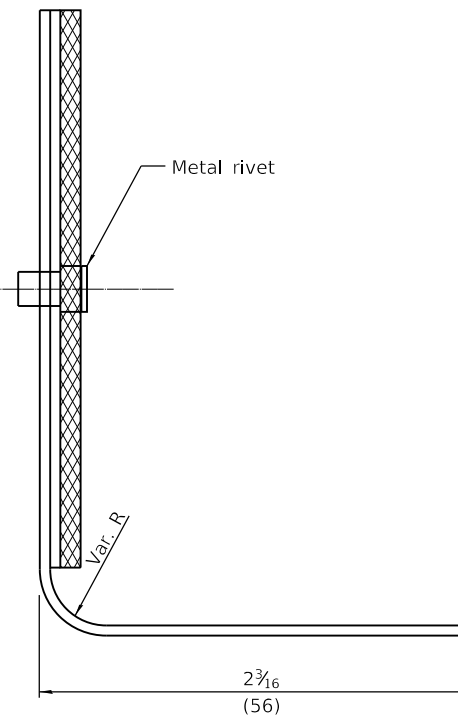
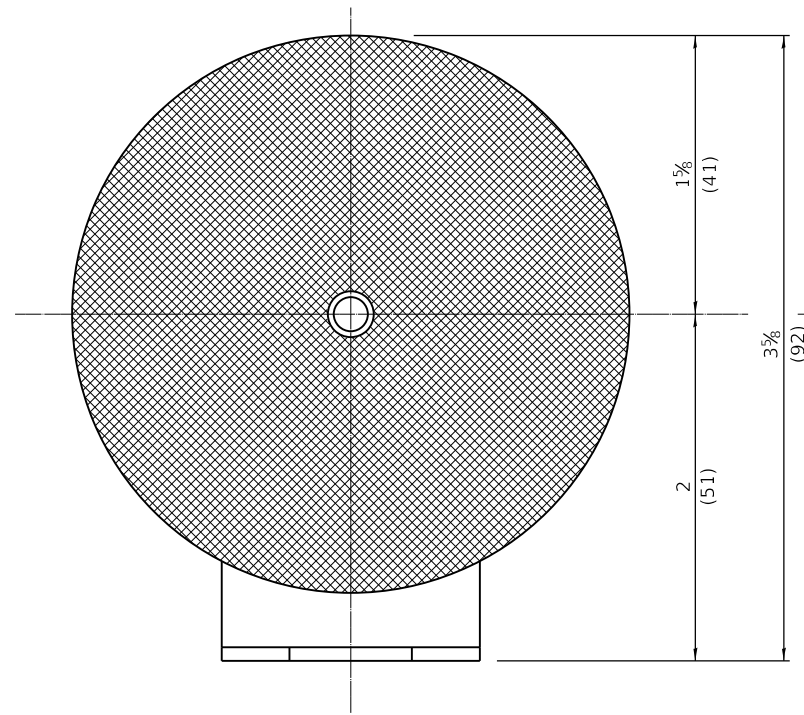
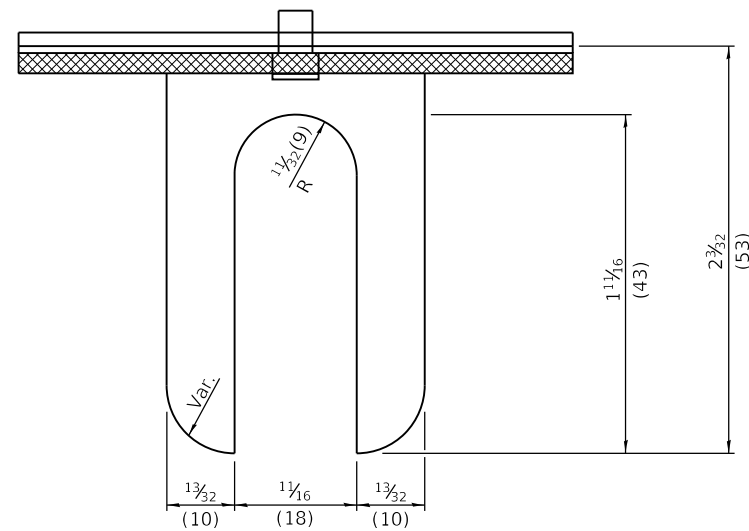

REFLECTOR TYPE A
(monodirectional shown)

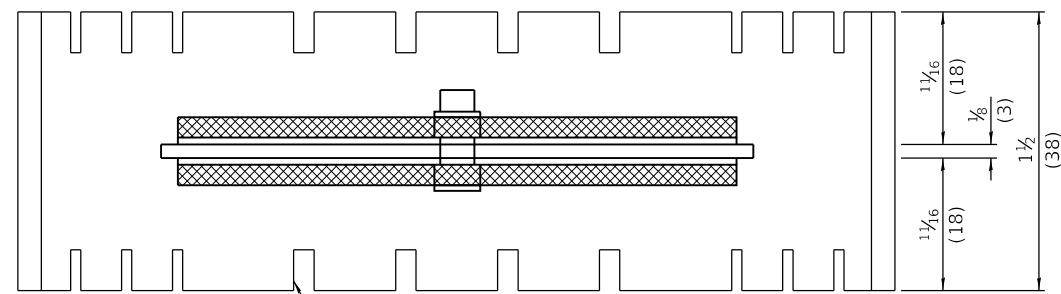

Adhesive weep slots or holes
equally spaced on both sides

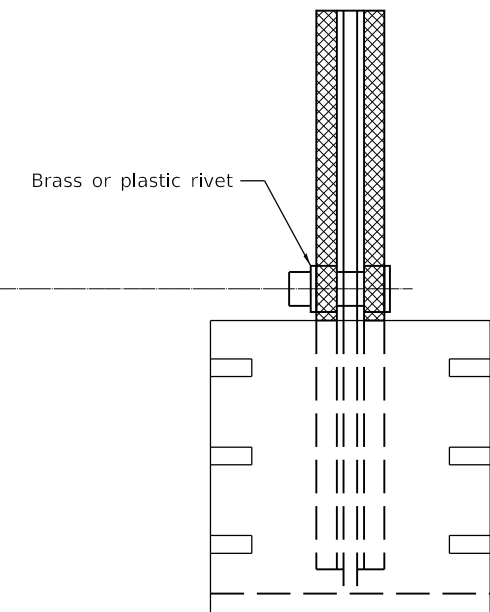
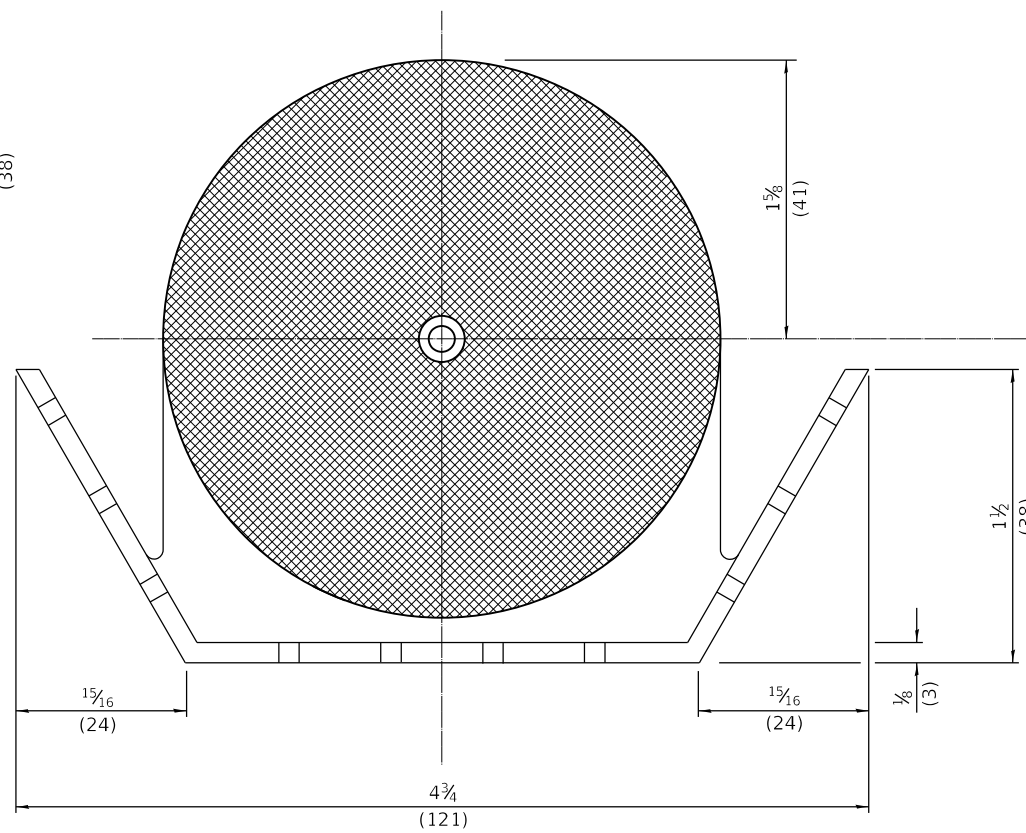

All dimensions are in inches (millimeters)
unless otherwise shown.

REFLECTOR TYPE B
(bidirectional shown)

DATE	REVISIONS
1-1-20	Revised from F-shape to constant slope parapet, revised note 3 on sht. 3, and fixed typo.
4-1-16	Added reflector spacing detail. Moved TERMINAL MARKER to std. 725001.

**GUARDRAIL AND
BARRIER WALL REFLECTOR
MOUNTING DETAILS**

(Sheet 1 of 3)

STANDARD 782006-01

Illinois Department of Transportation

PASSED January 1, 2020
Amy Allen
ENGINEER OF OPERATIONS

APPROVED January 1, 2020
John E. ...
ENGINEER OF DESIGN AND ENVIRONMENT

ISSUED 1-1-2000

Reflective area. May be rectangular or slight trapezoid.

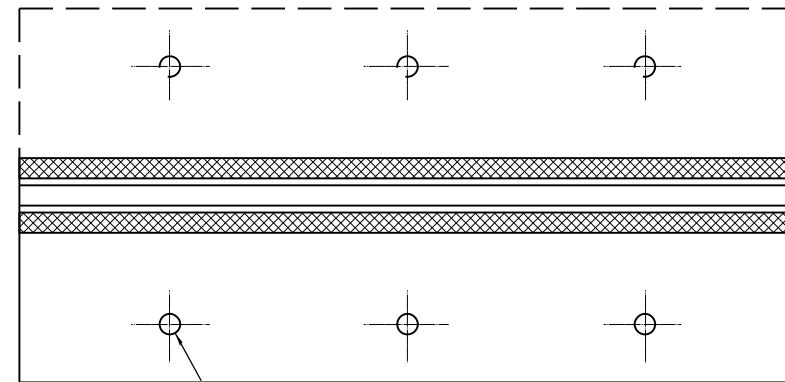
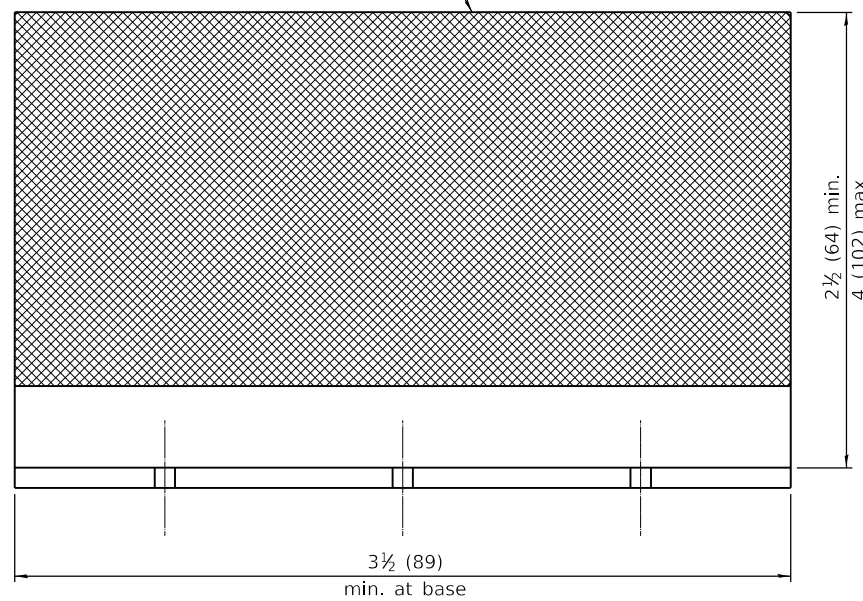

3 min. adhesive weep holes or slots each side, variable spacing.

Minimum total area of base 7.0 sq. in. (4,516 mm²)

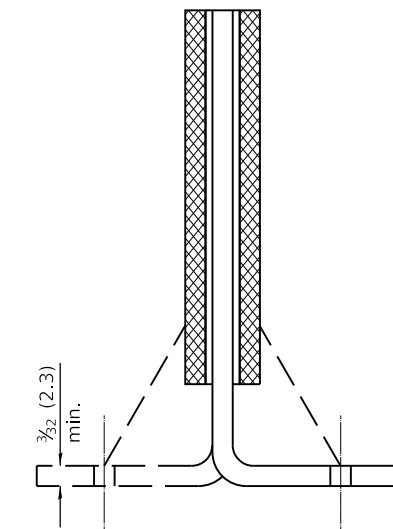

Cross section may be "T" or "L" shaped and may have side supports at ends.

REFLECTOR TYPE C

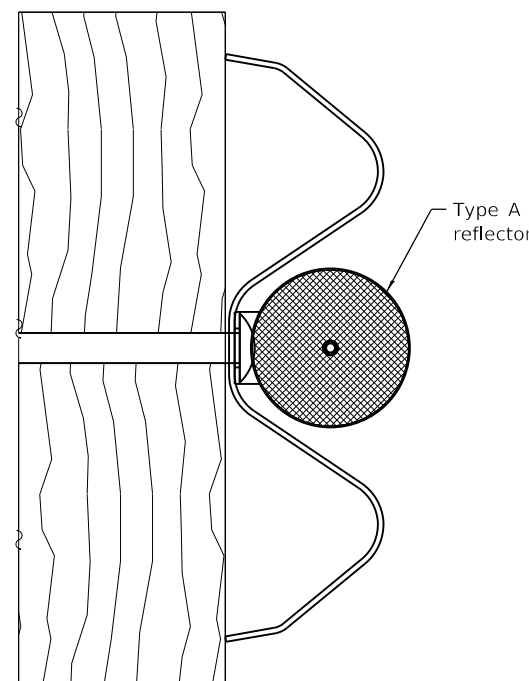

TYPICAL MOUNTING DETAIL FOR GUARDRAIL REFLECTOR

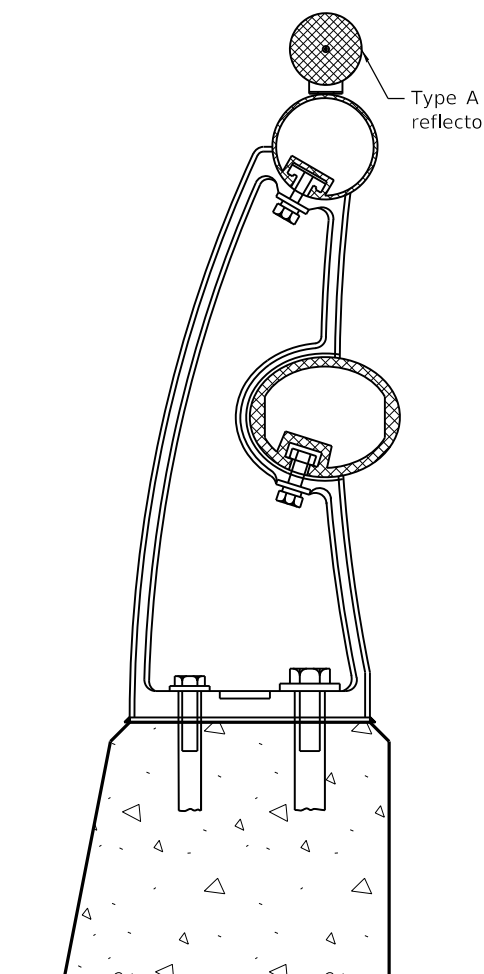
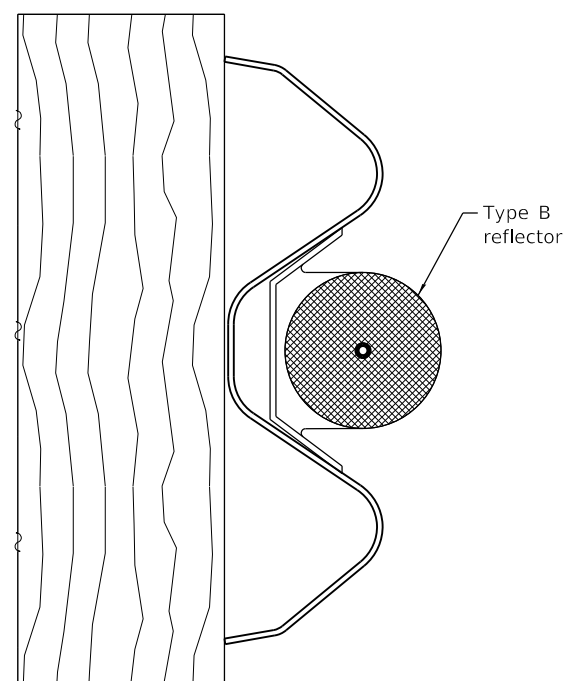

TYPICAL MOUNTING DETAIL FOR BRIDGE RAIL REFLECTOR

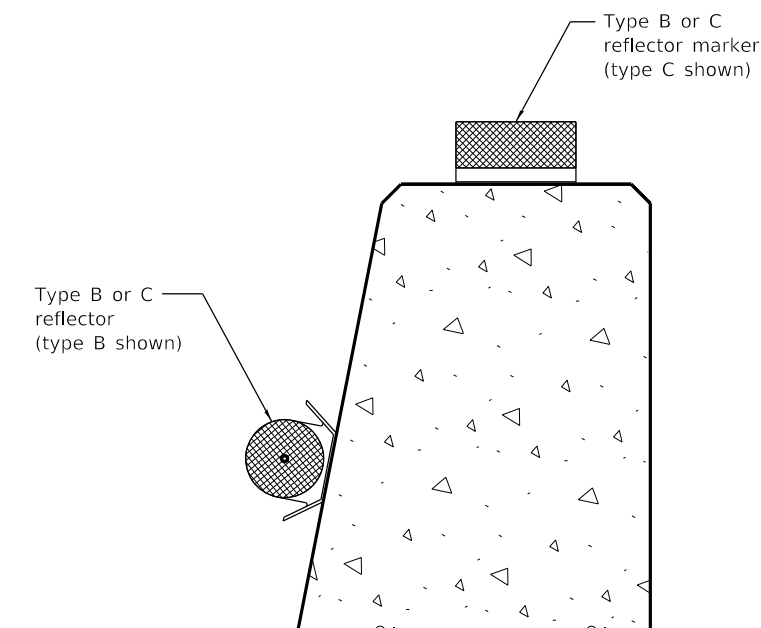

TYPICAL MOUNTING DETAIL FOR BARRIER WALL REFLECTOR

Illinois Department of Transportation

PASSED January 1, 2020
Amy Allen
ENGINEER OF OPERATIONS

APPROVED January 1, 2020
Joe E. ...
ENGINEER OF DESIGN AND ENVIRONMENT

ISSUED 1-1-2000

GUARDRAIL AND BARRIER WALL REFLECTOR MOUNTING DETAILS

(Sheet 2 of 3)

STANDARD 782006-01

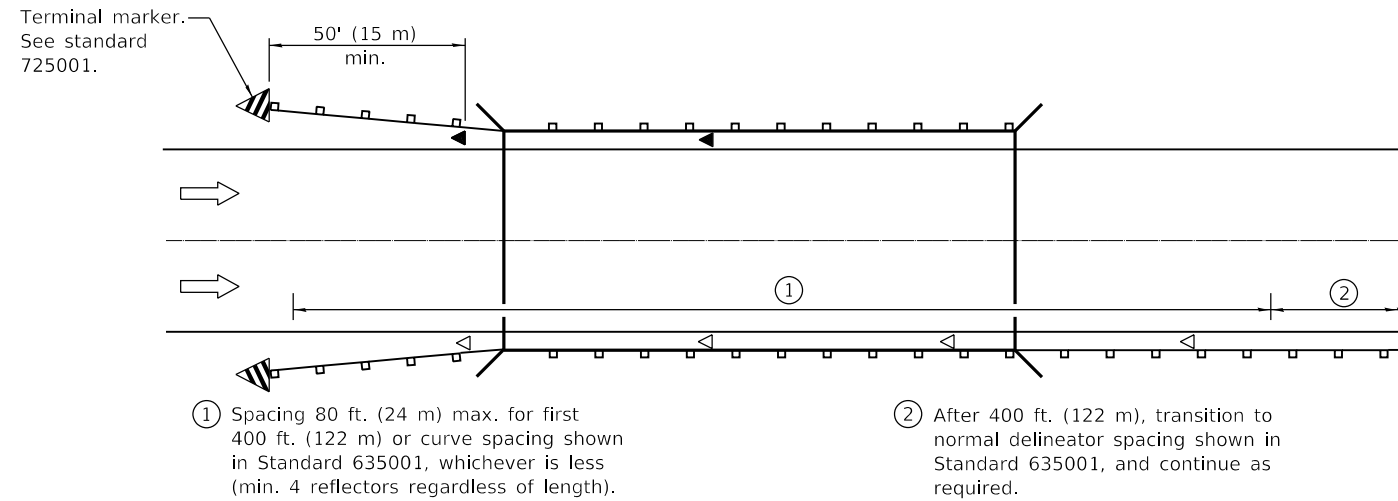

ONE-WAY TRAFFIC

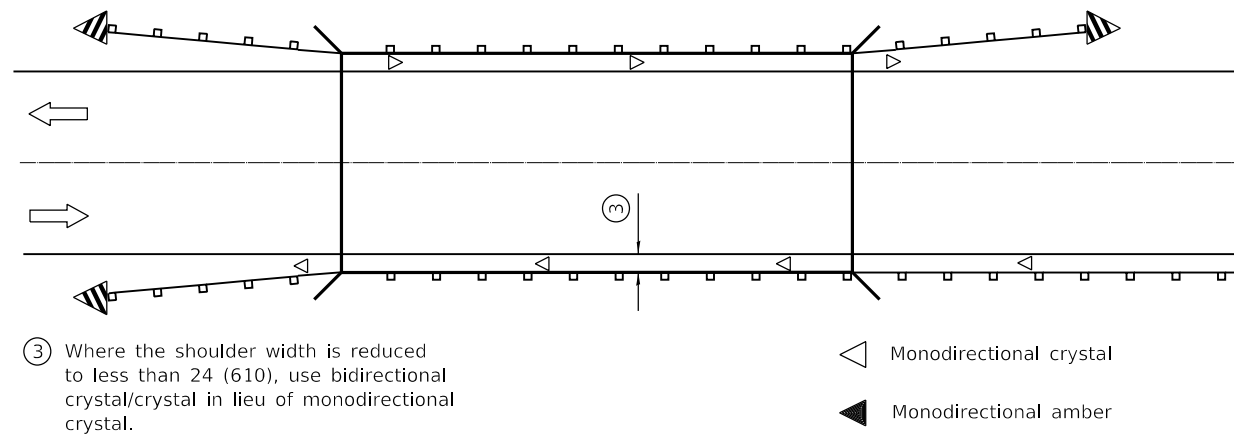

TWO-WAY TRAFFIC

GUARDRAIL / BARRIER WALL
REFLECTOR PLACEMENT DETAIL

Illinois Department of Transportation

PASSED January 1, 2020

Amy Allen
ENGINEER OF OPERATIONS

APPROVED January 1, 2020

J. E. ...
ENGINEER OF DESIGN AND ENVIRONMENT

ISSUED 1-1-2000

**GUARDRAIL AND
BARRIER WALL REFLECTOR
MOUNTING DETAILS**

(Sheet 3 of 3)

STANDARD 782006-01

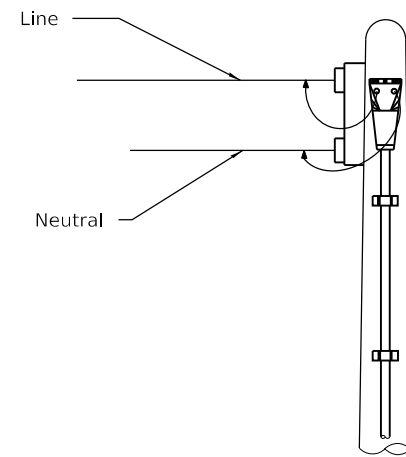
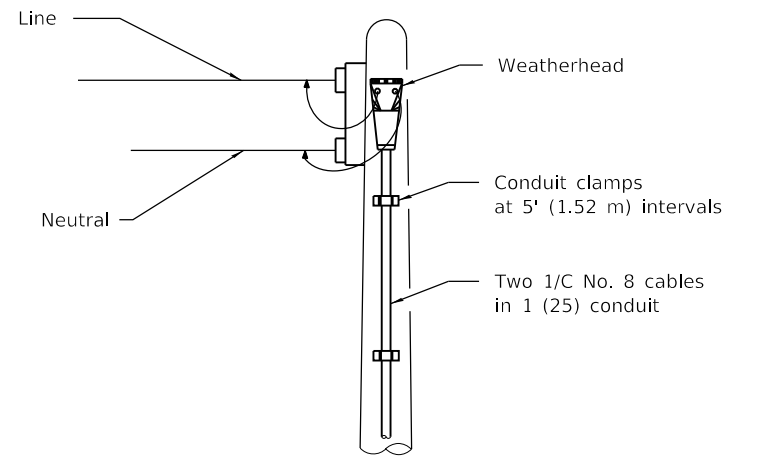

Except for the changes noted below, details for TYPE A and TYPE B service installations shall correspond.

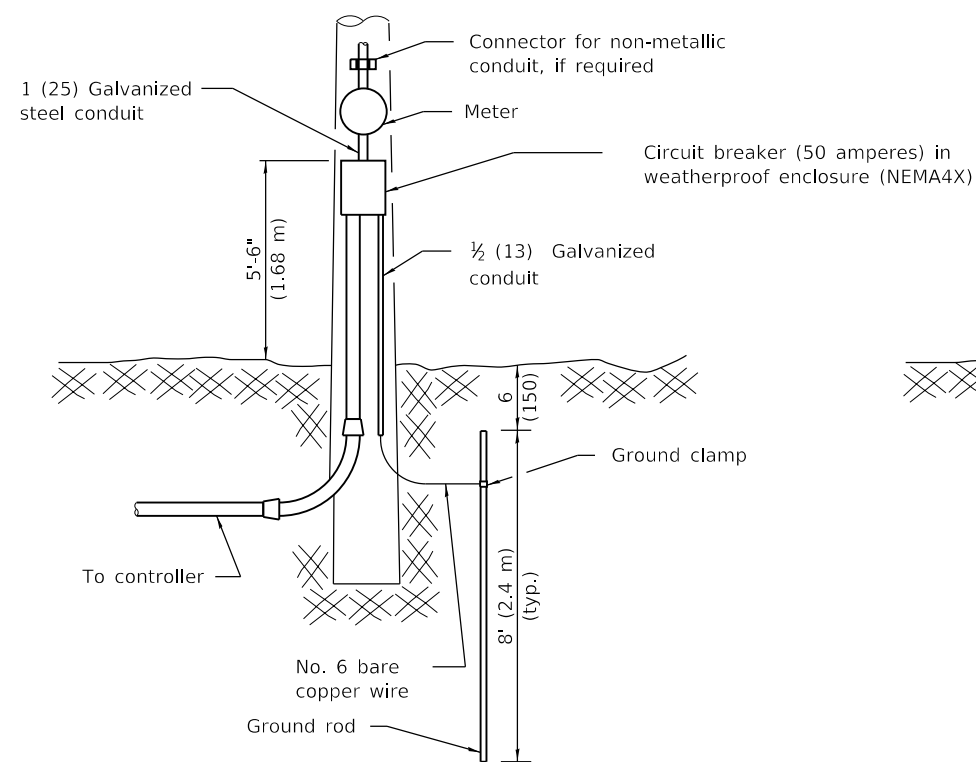

TYPE A

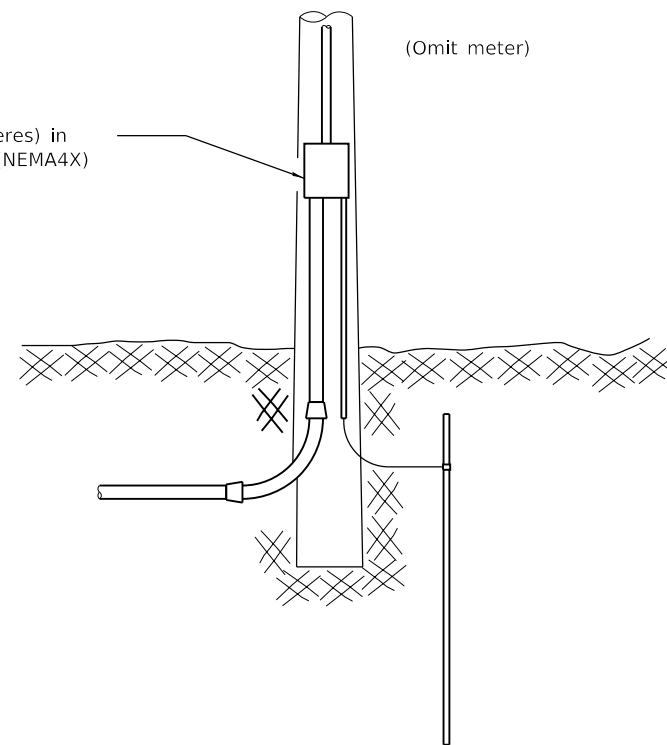

TYPE B

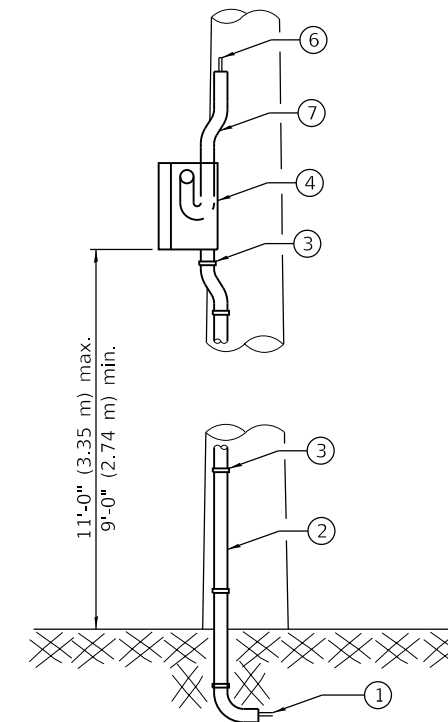

The following equipment is to be furnished and installed on the TYPE C installation.

- ① Cable in conduit (electric cable, No. 6, 2/C except where otherwise specified)
- ② Galvanized steel conduit 1 1/4 (32) with bend
- ③ Galvanized conduit clamps
- ④ Aluminum weatherproof box with gasketed cover. Weatherproof box shall be installed facing the adjacent property line. (See diagram for alternate installation.)
- ⑤ Ground stud for neutral connection
- ⑥ Service cables
- ⑦ Offset weatherproof fitting
- ⑧ Circuit breaker

TYPE C

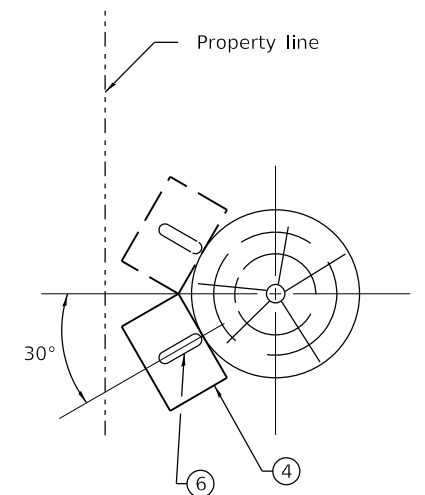
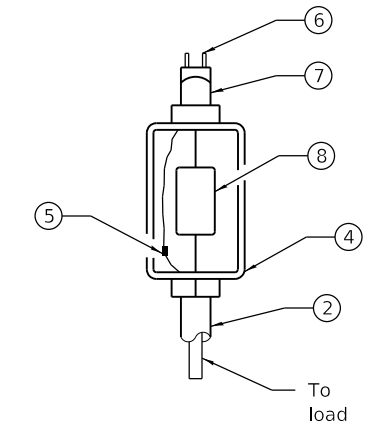

ALTERNATE INSTALLATION

(Installation when weatherproof box cannot be installed facing the adjacent property line.)

All dimensions are in inches (millimeters) unless otherwise shown.

Illinois Department of Transportation

PASSED January 1, 2009

ENGINEER OF OPERATIONS

APPROVED January 1, 2009

ENGINEER OF DESIGN AND ENVIRONMENT

ISSUED 1-1-02

DATE	REVISIONS
1-1-09	Switched units to English (metric).
1-1-02	Renum. Standard 2373-1.

ELECTRICAL SERVICE INSTALLATION DETAILS

STANDARD 805001-01

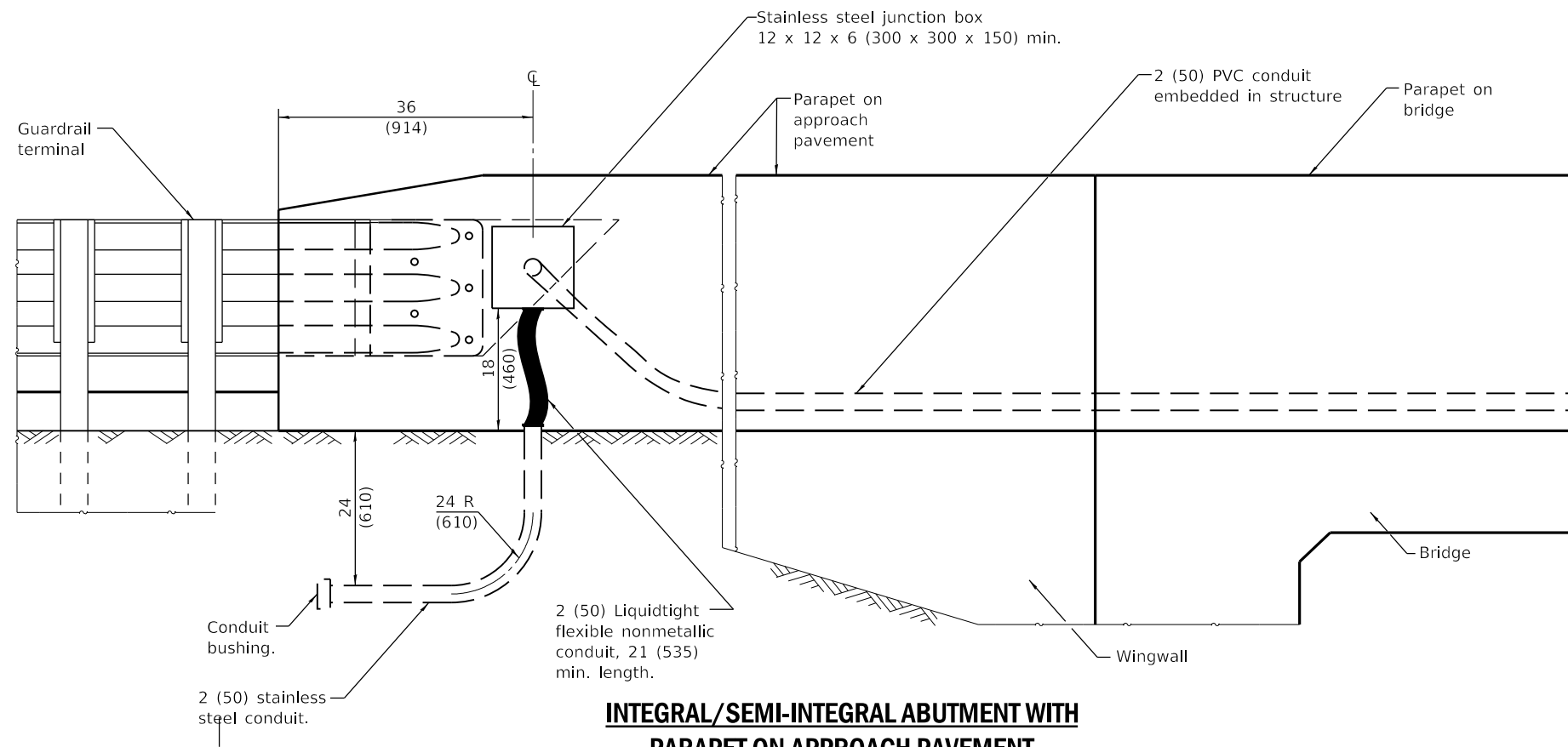

**INTEGRAL/SEMI-INTEGRAL ABUTMENT WITH
PARAPET ON APPROACH PAVEMENT**

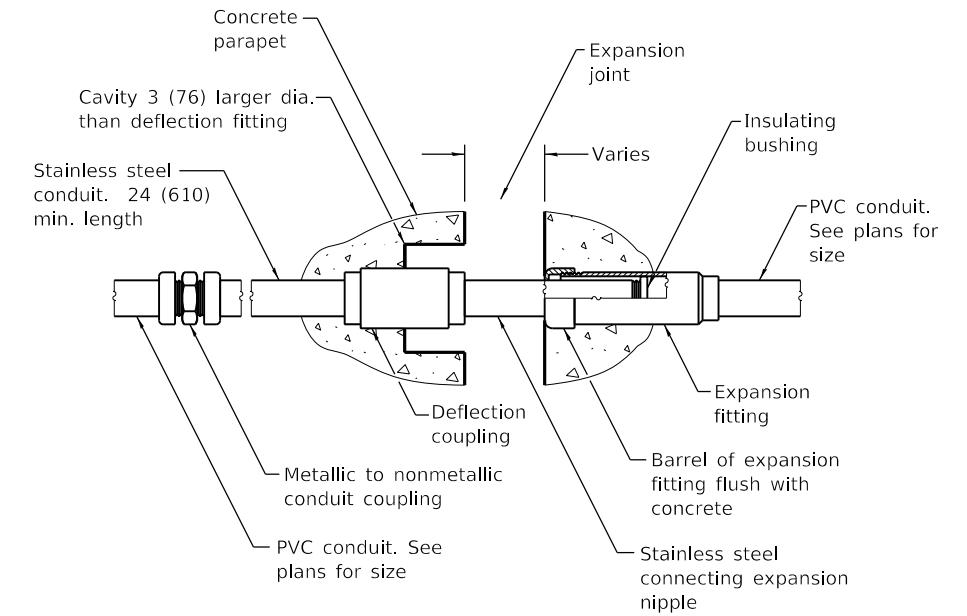

COMBINATION EXPANSION/ DEFLECTION FITTING

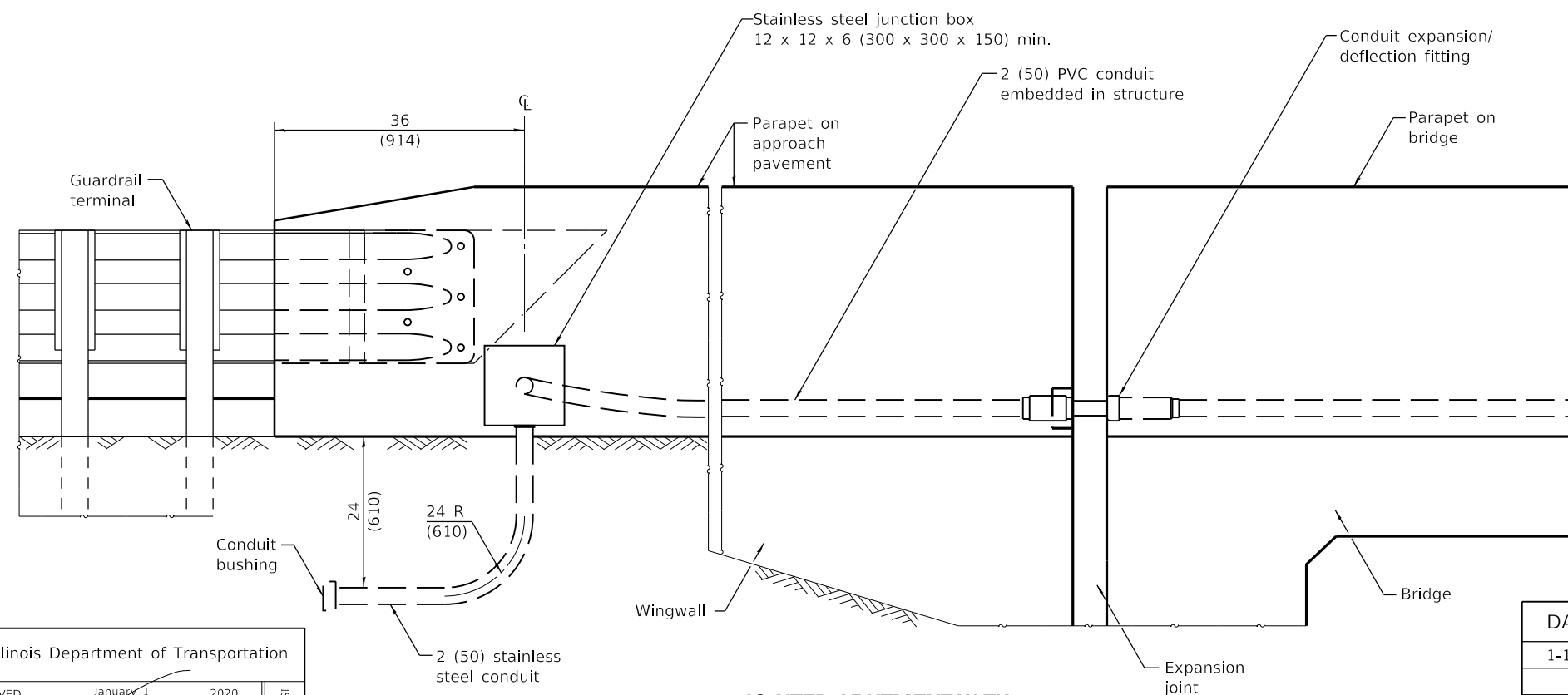

**JOINTED ABUTMENT WITH
PARAPET ON APPROACH PAVEMENT**

GENERAL NOTES

The barrel in the expansion fitting shall be fully embedded in the concrete on one side of the expansion joint. One half the length of the deflection fitting shall be embedded in the concrete on the other side of the expansion joint.

The Contractor shall install combination expansion deflection fittings at all bridge expansion joints.

With the approval of the Engineer, the Contractor may substitute two 12 x 12 x 6 (300 x 300 x 150) min. stainless steel junction boxes attached to back of wall and connected with liquidtight flexible nonmetallic conduit for all expansion joints.

See Standard 631031 for details of steel connector plate for constant slope parapet.

All dimensions are in inches (millimeters) unless otherwise shown.

DATE	REVISIONS
1-1-20	Revised from F-Shape to constant slope parapet, added general note for steel connector plate, revised standard name, and fixed typo.
1-1-15	New standard.

**RACEWAYS EMBEDDED
IN STRUCTURE**

(Sheet 1 of 3)

STANDARD 812001-01

Illinois Department of Transportation

APPROVED January 1, 2020
ME Reppelt
ELECTRICAL AND MECHANICAL UNIT CHIEF

APPROVED January 1, 2020
J. E. ...
ENGINEER OF DESIGN AND ENVIRONMENT

ISSUED 1-1-15

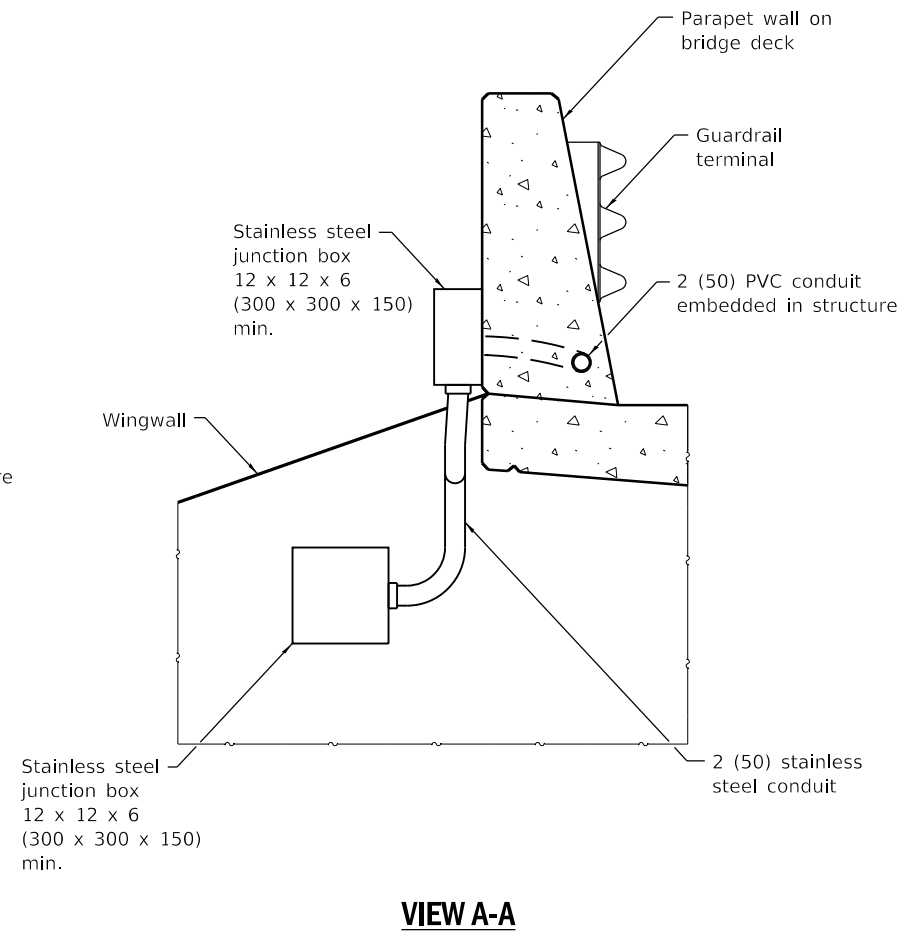
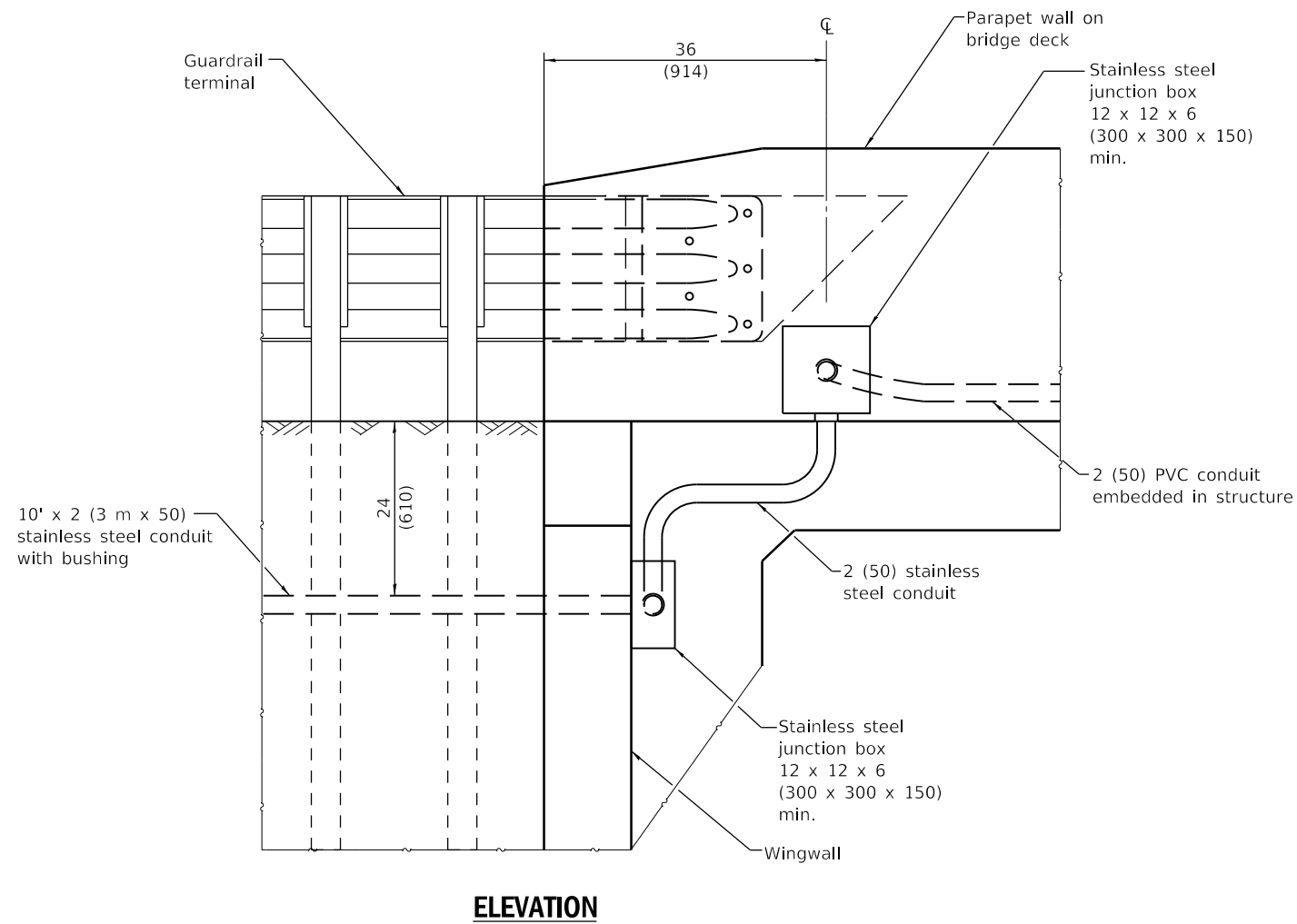
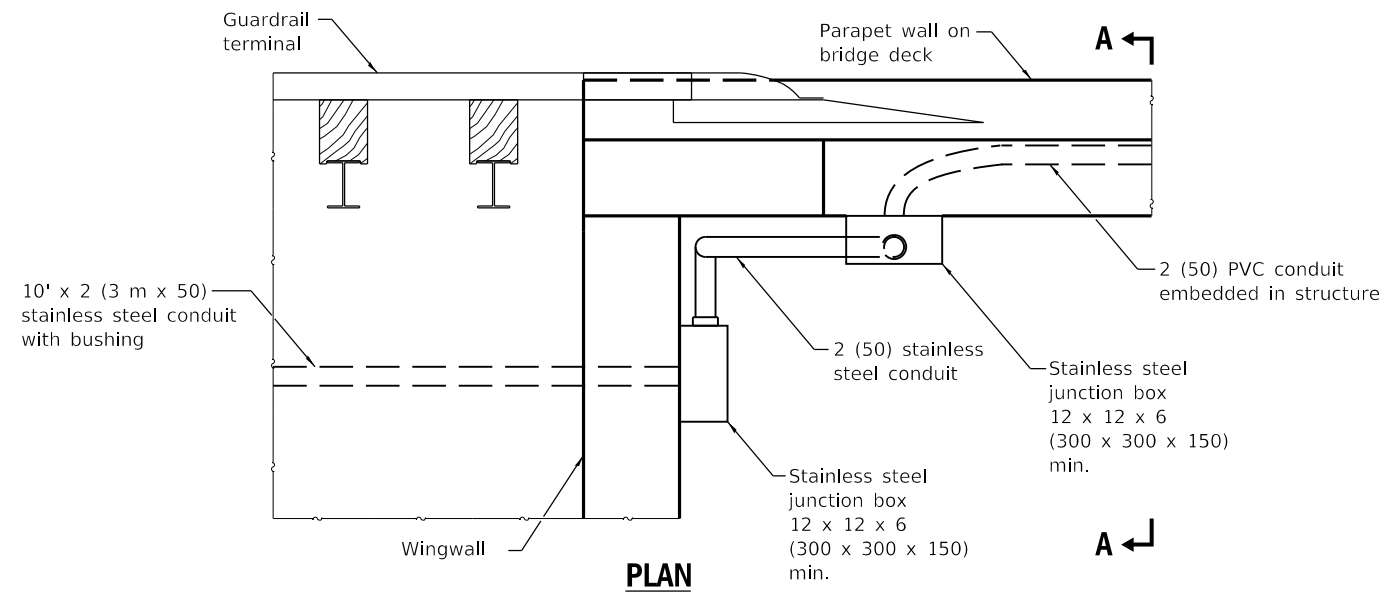

**INTEGRAL/SEMI-INTEGRAL ABUTMENT WITH
PARAPET ENDING ON BRIDGE DECK**

**RACEWAYS EMBEDDED
IN STRUCTURE**

(Sheet 2 of 3)

STANDARD 812001-01

Illinois Department of Transportation

APPROVED January 1, 2020

ME Reppelt
ELECTRICAL AND MECHANICAL UNIT CHIEF

APPROVED January 1, 2020

J. E. ...
ENGINEER OF DESIGN AND ENVIRONMENT

ISSUED 1-1-15

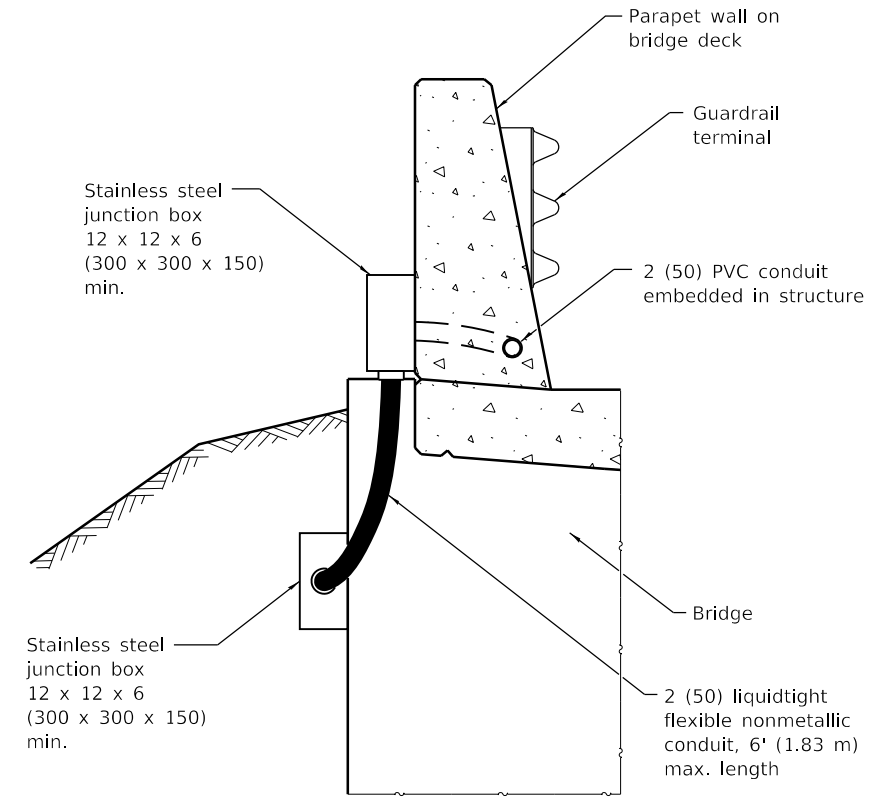
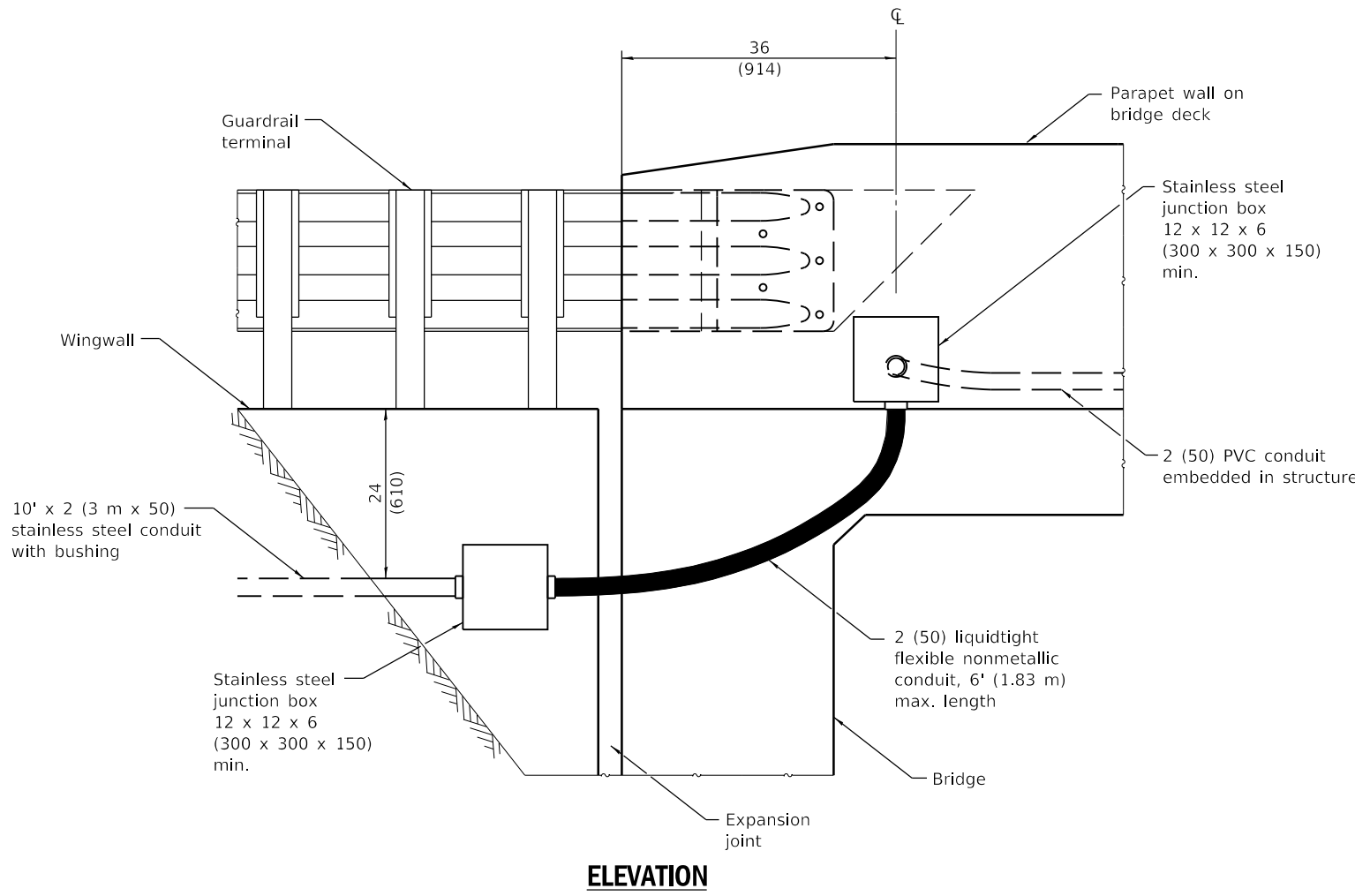
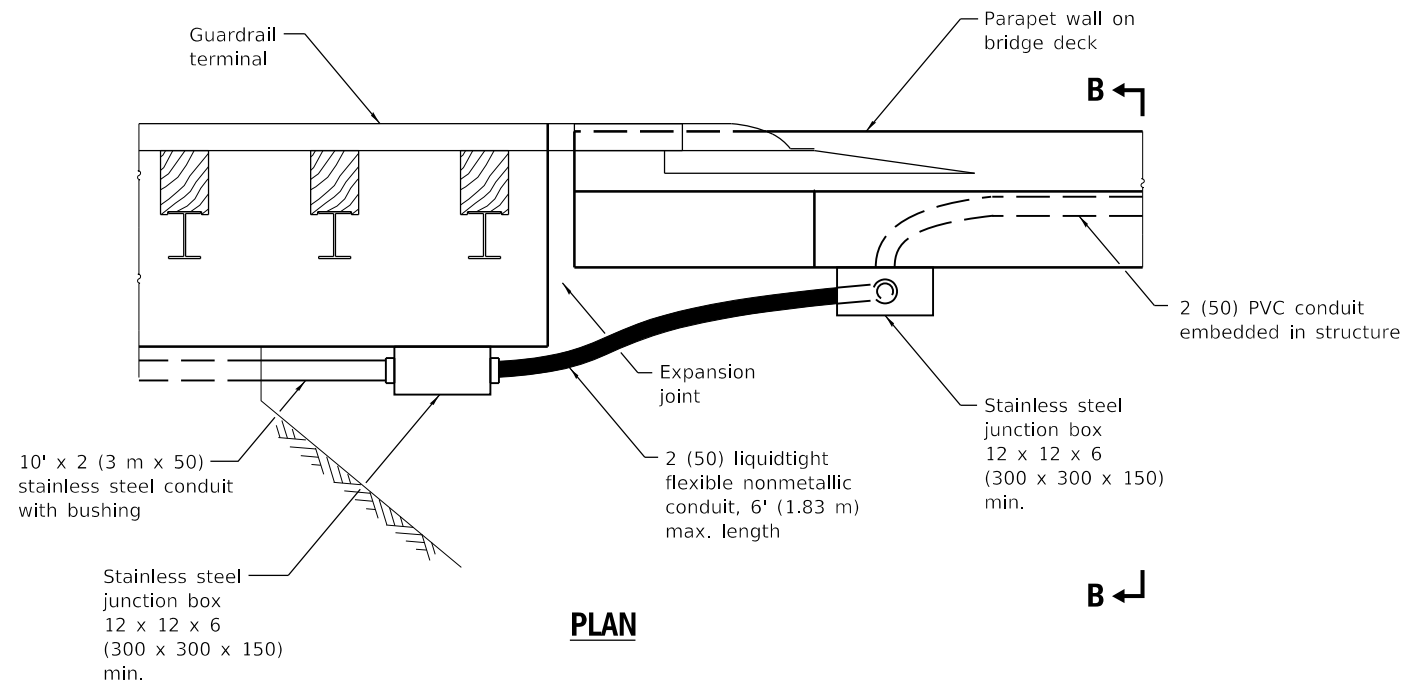

**JOINTED ABUTMENT WITH
PARAPET ENDING ON BRIDGE DECK**

**RACEWAYS EMBEDDED
IN STRUCTURE**

(Sheet 3 of 3)

STANDARD 812001-01

Illinois Department of Transportation

APPROVED January 1, 2020

ME Reppelt
ELECTRICAL AND MECHANICAL UNIT CHIEF

APPROVED January 1, 2020

J. E. ...
ENGINEER OF DESIGN AND ENVIRONMENT

ISSUED 1-1-15

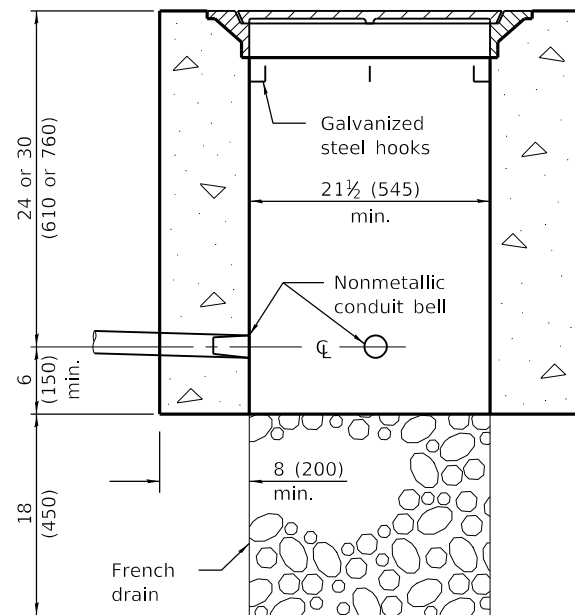
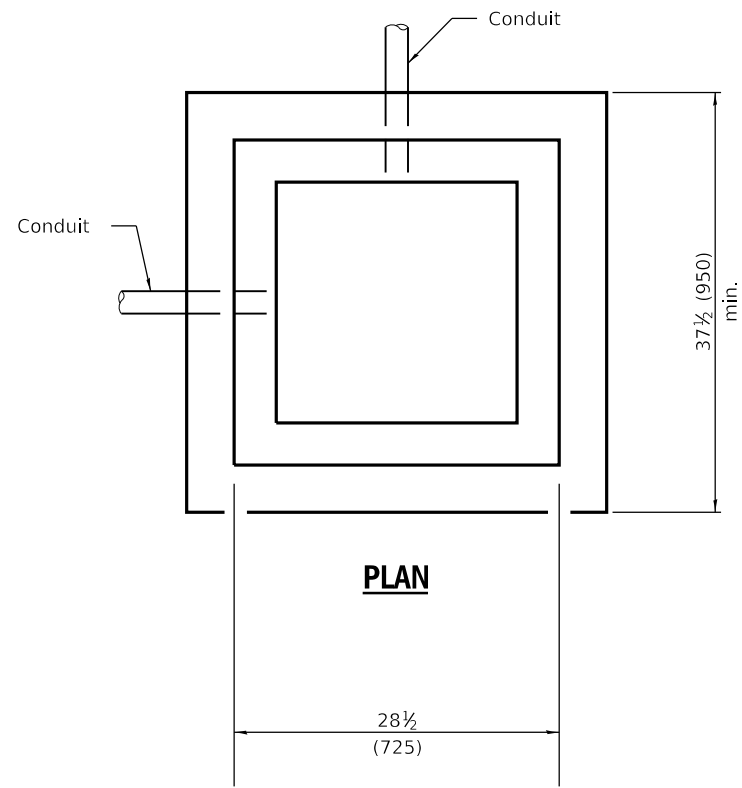

ELEVATION

PORTLAND CEMENT CONCRETE

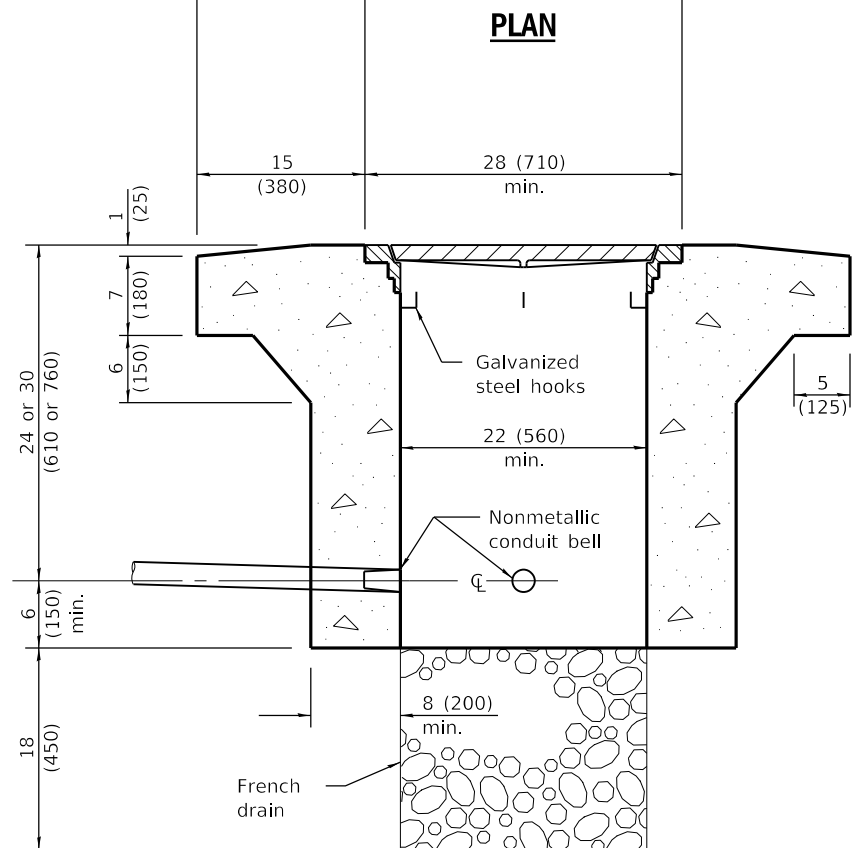
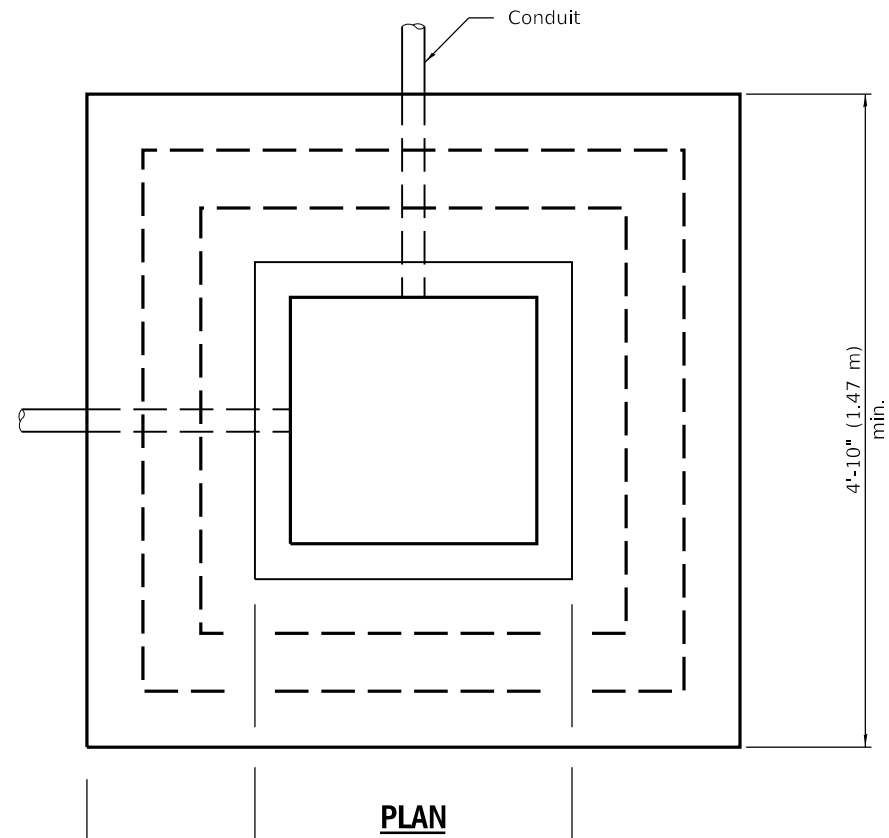

ELEVATION

PORTLAND CEMENT CONCRETE

HEAVY DUTY

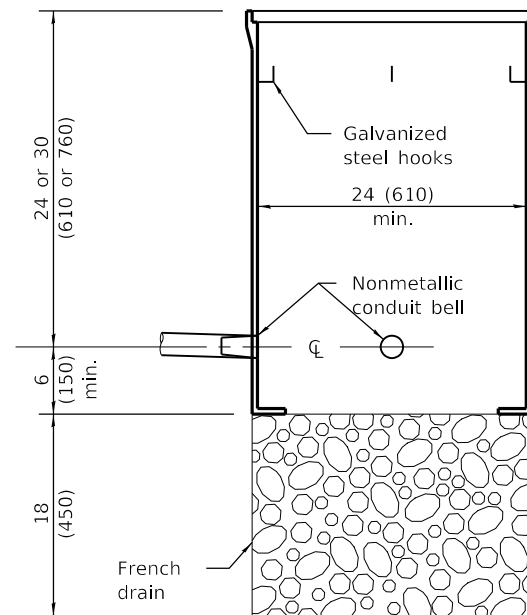
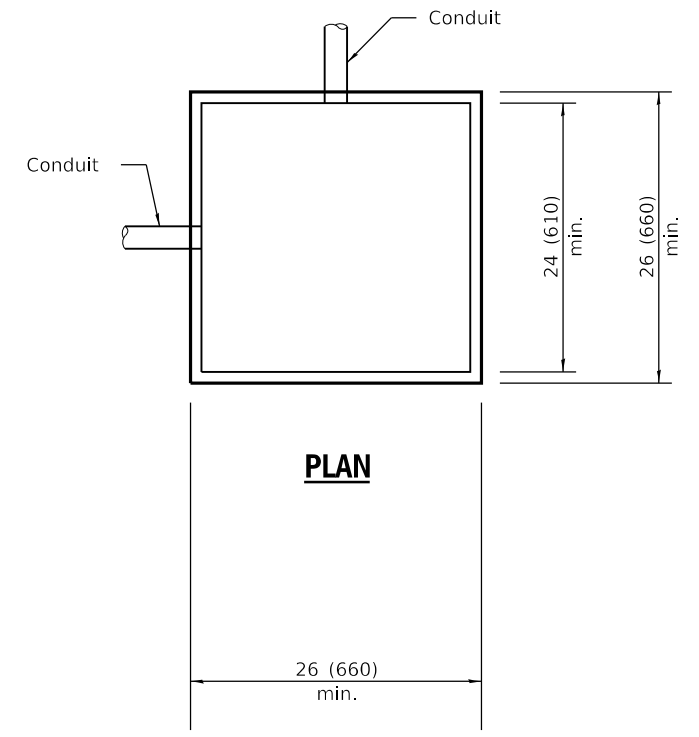

ELEVATION

COMPOSITE CONCRETE

QUANTITIES

Depth	Concrete yd ³ (m ³)	
	Handhole	Heavy Duty Handhole
30 (762)	0.61 (0.47)	0.98 (0.75)
36 (914)	0.73 (0.56)	1.10 (0.84)

All dimensions are in inches (millimeters) unless otherwise shown.

DATE	REVISIONS
1-1-15	Corrected dimension on heavy duty handhole. Added concrete quantities table.
1-1-09	Switched units to English (metric).

HANDHOLES

STANDARD 814001-03

Illinois Department of Transportation

PASSED January 1, 2015

ENGINEER OF OPERATIONS

APPROVED January 1, 2015

ENGINEER OF DESIGN AND ENVIRONMENT

ISSUED 1-1-97

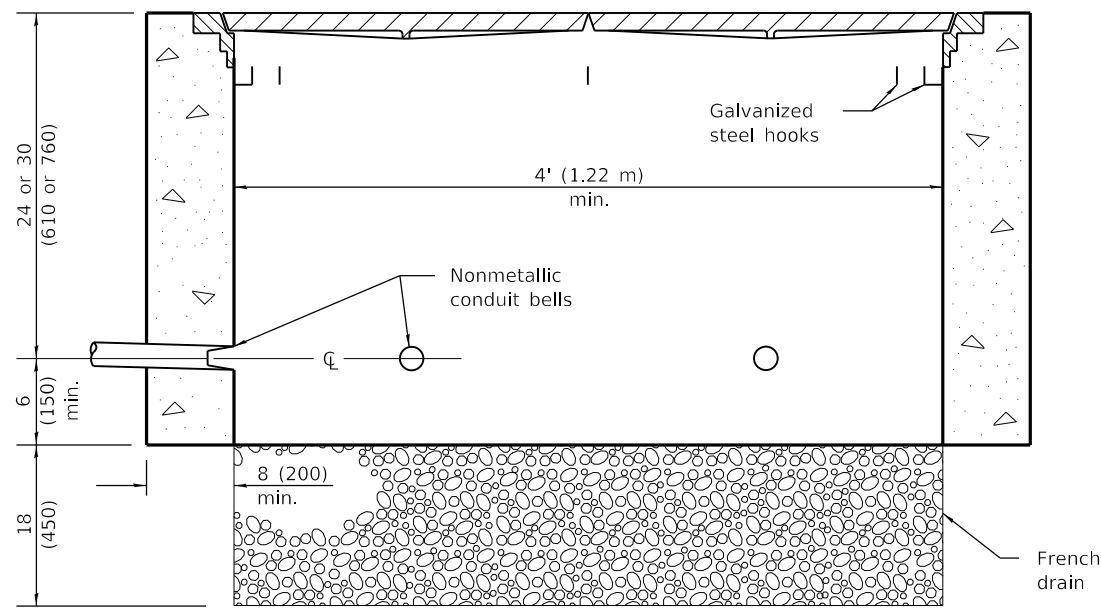
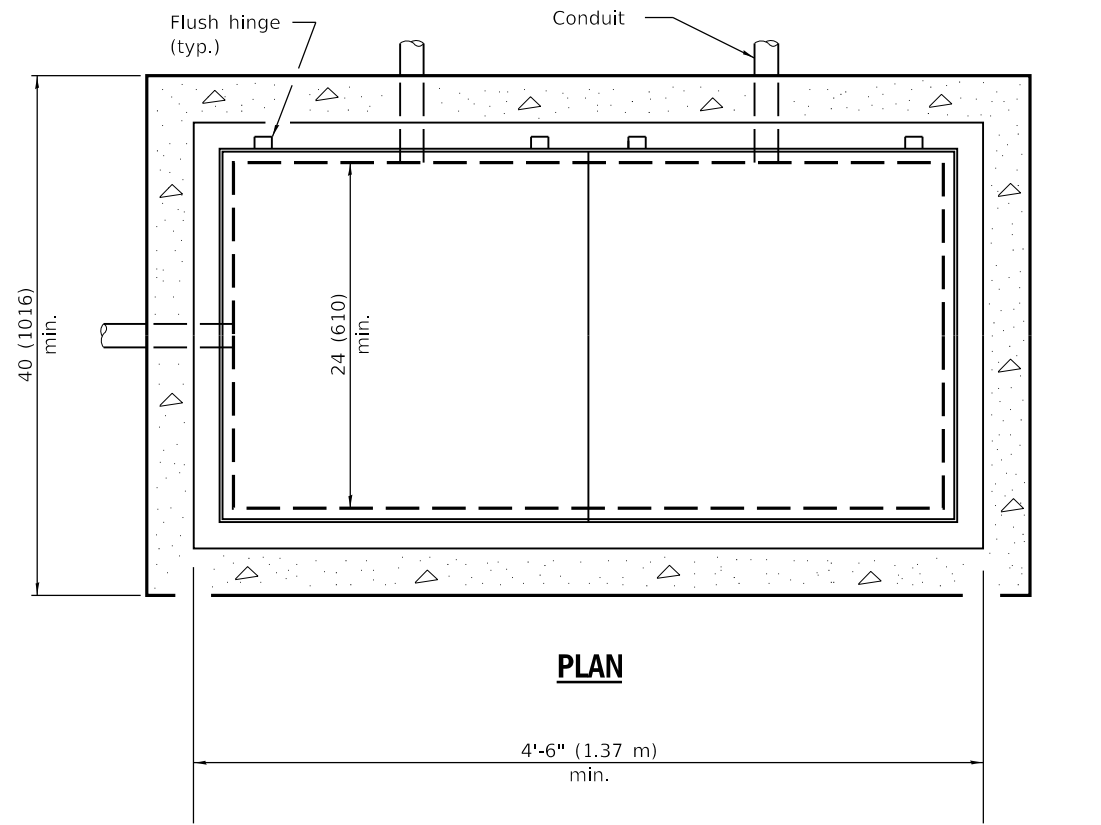

ELEVATION
PORTLAND CEMENT CONCRETE

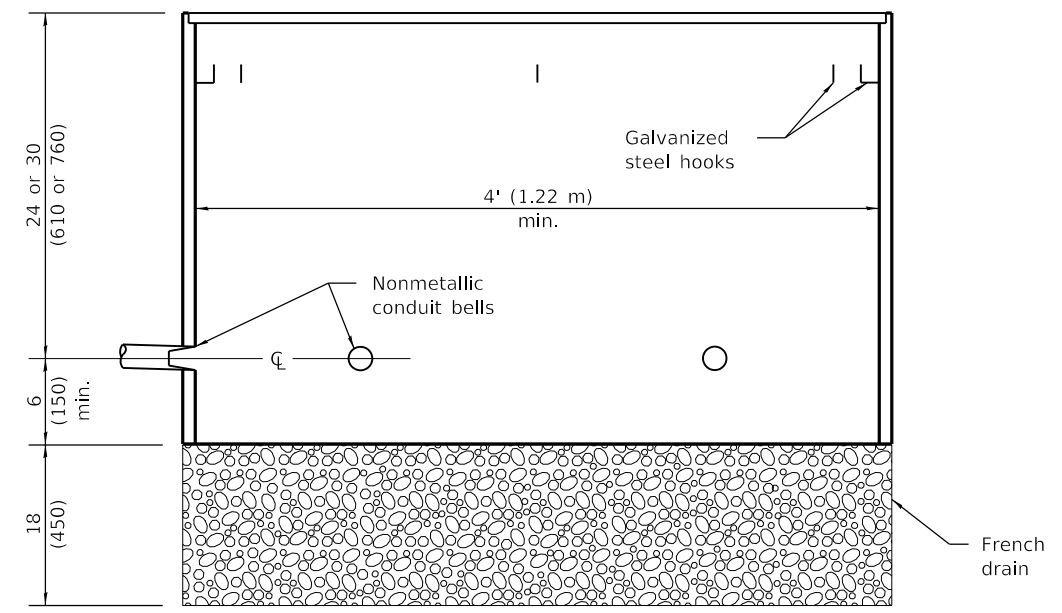
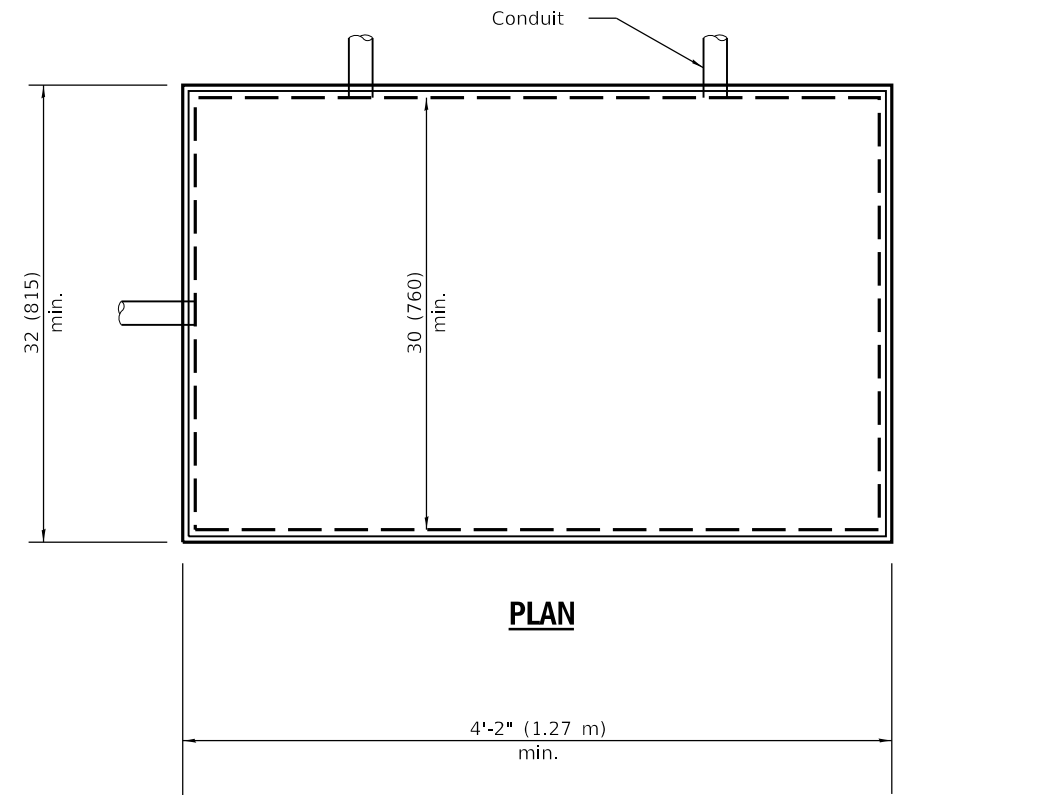

ELEVATION
COMPOSITE CONCRETE

All dimensions are in inches (millimeters) unless otherwise shown.

DATE	REVISIONS
1-1-21	Corrected dimension in Portland Cement Concrete Plan view.
1-1-09	Switched units to English (metric).

DOUBLE HANDHOLES

STANDARD 814006-03

Illinois Department of Transportation

PASSED January 1, 2021
Amy Ellis
ENGINEER OF OPERATIONS

APPROVED January 1, 2021
S. E. EG
ENGINEER OF DESIGN AND ENVIRONMENT

ISSUED 1-1-97

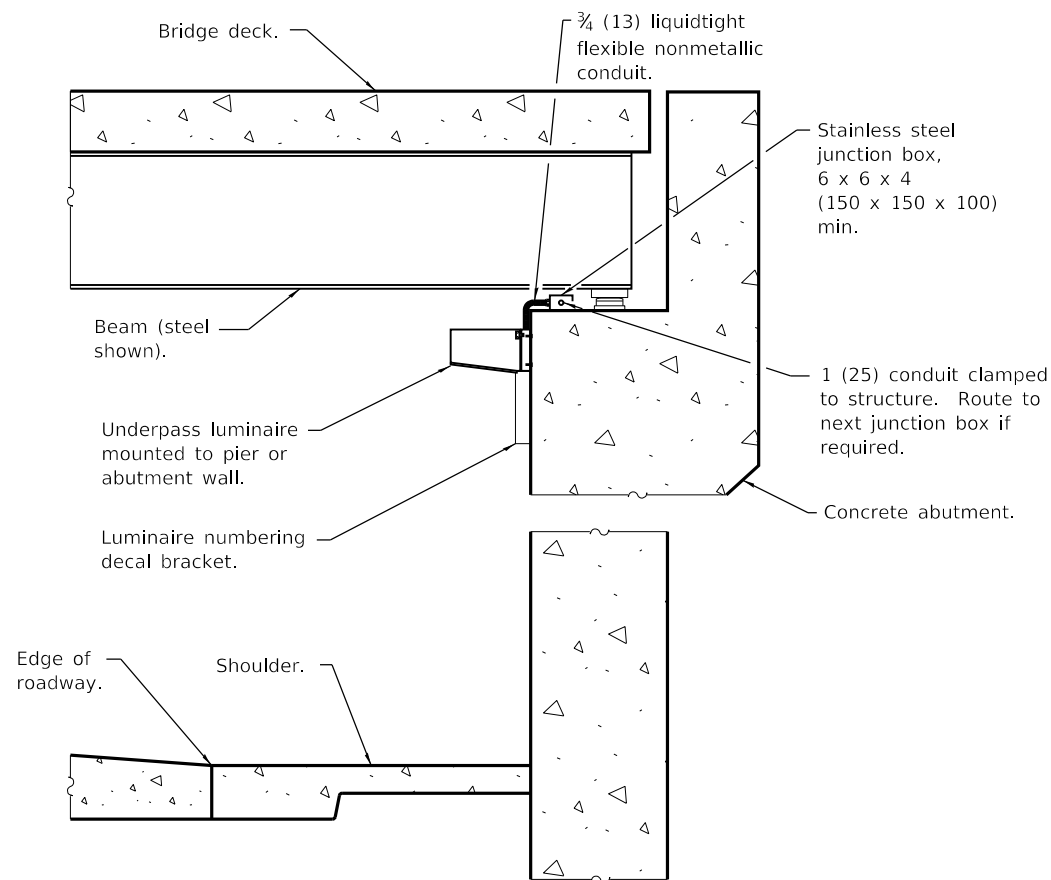

SECTION A-A

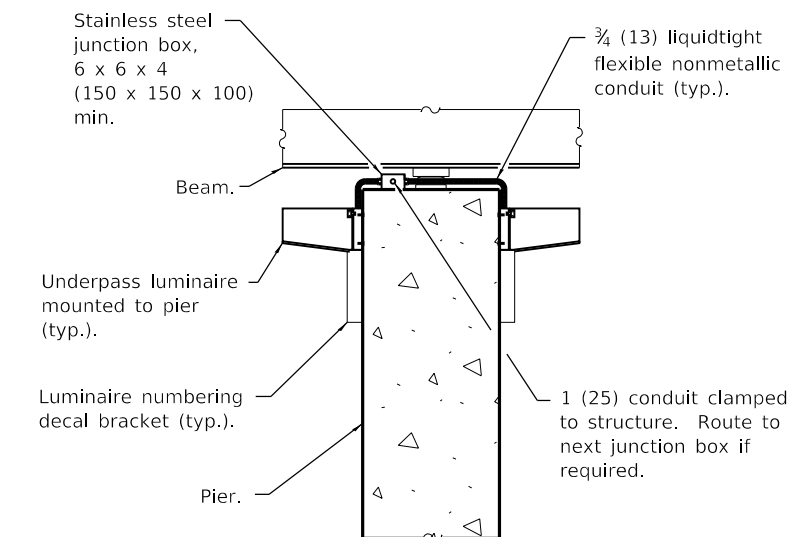

CENTER PIER DETAIL

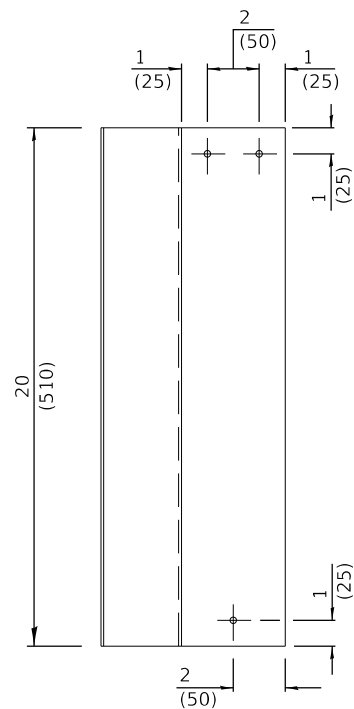

ELEVATION

LUMINAIRE NUMBERING DECAL BRACKET MOUNTING DETAIL

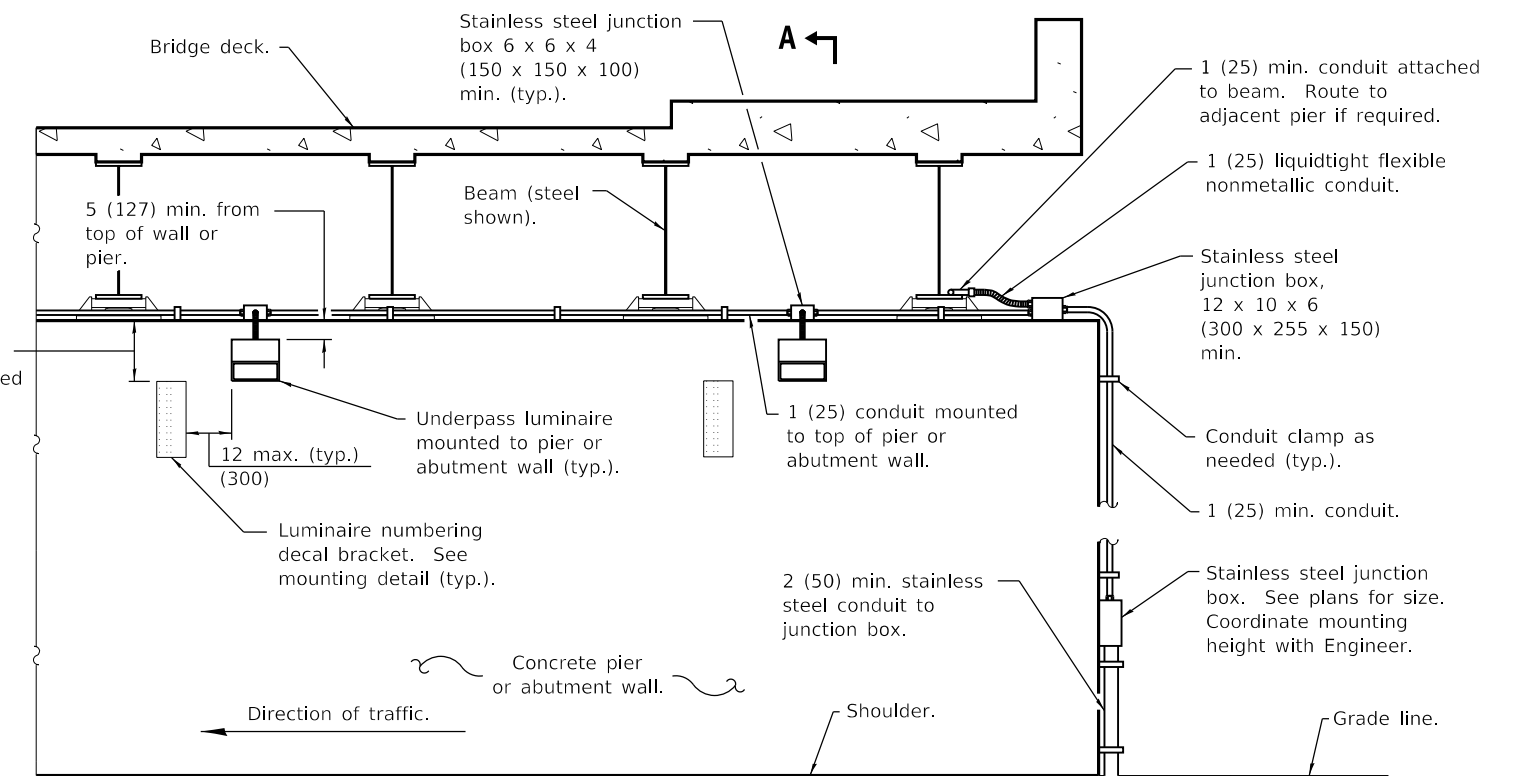

PIER / ABUTMENT WALL ELEVATION

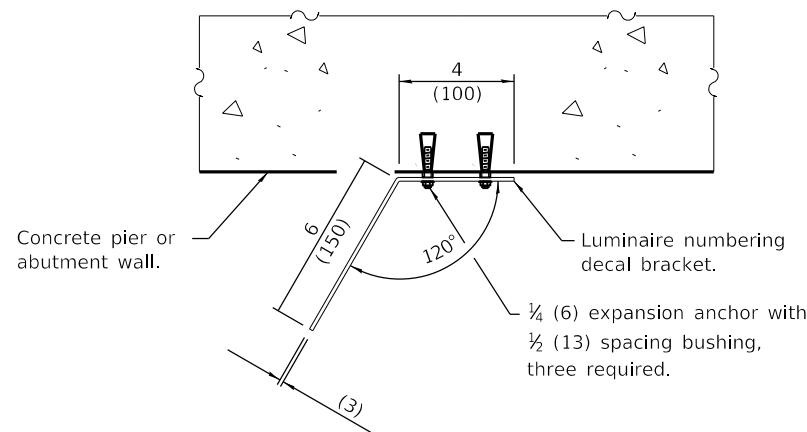

TOP VIEW

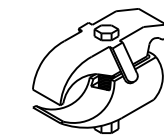

CONDUIT BEAM CLAMP

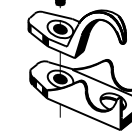

CONDUIT CLAMP

GENERAL NOTES

See plans for underpass luminaire locations.

Rigid conduit may be used in lieu of flexible conduit.

Stainless steel conduit shall be used beneath any openings in the bridge deck.

Branch circuits to luminaire shown routed from underground. Branch circuits may be routed from bridge parapet above.

All dimensions are in inches (millimeters) unless otherwise shown.

DATE	REVISIONS
4-1-16	New standard.

UNDERPASS LIGHTING WALL MOUNT

STANDARD 821001

Illinois Department of Transportation

PASSED April 1, 2016

ENGINEER OF PRELIMINARY ENGINEERING

APPROVED April 1, 2016

ENGINEER OF DESIGN AND ENVIRONMENT

ISSUED 1-1-16

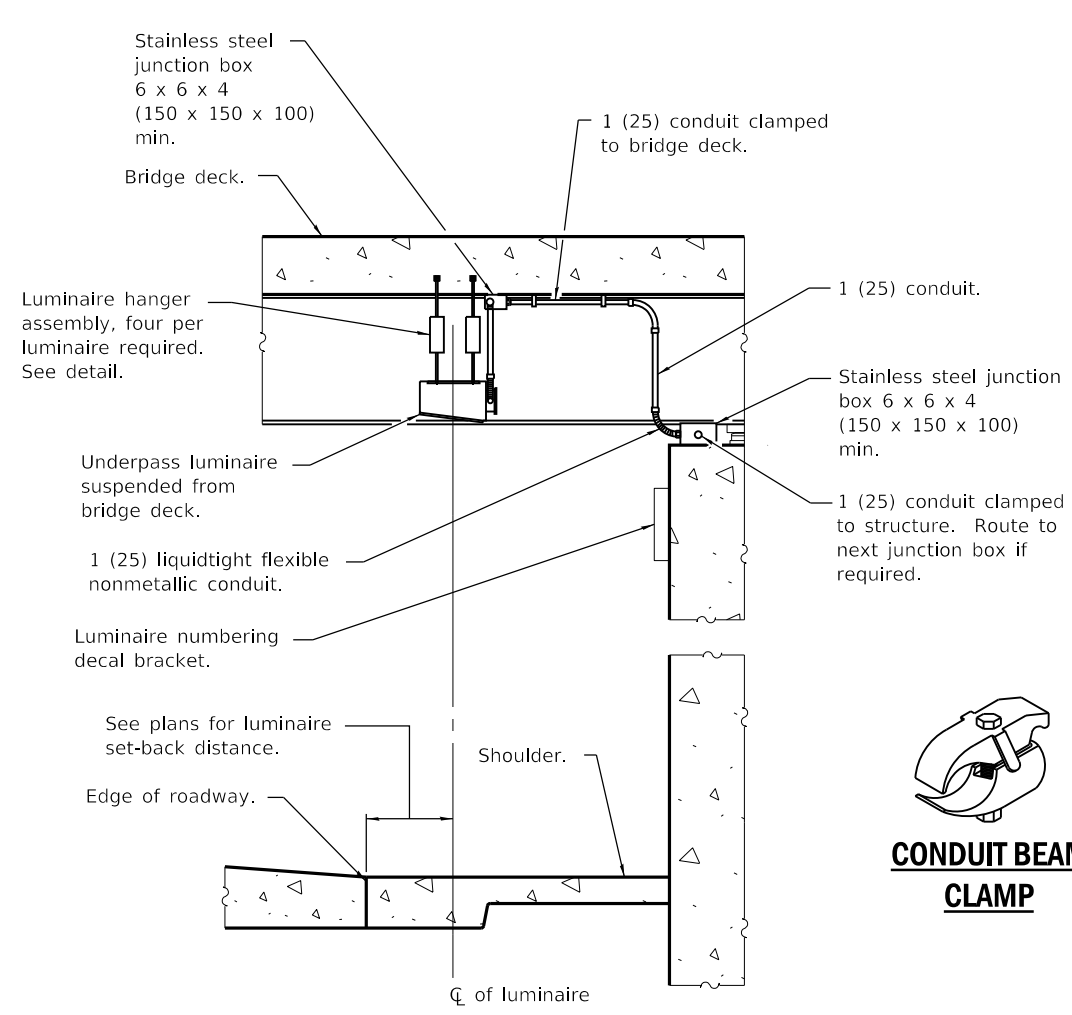

SECTION A-A

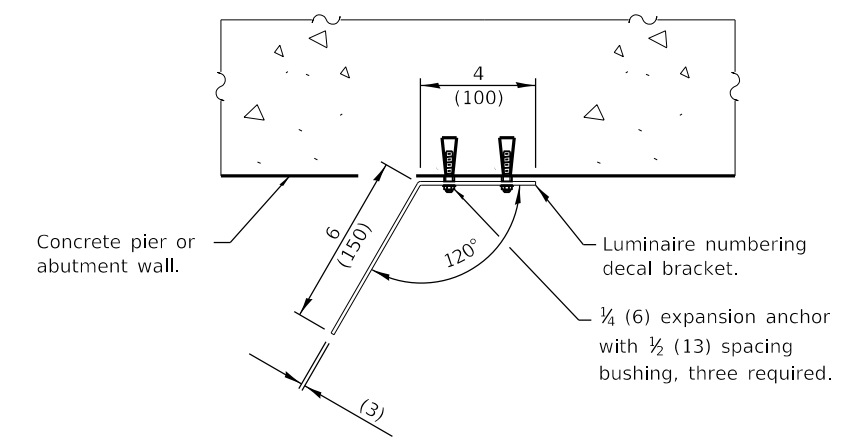

TOP VIEW

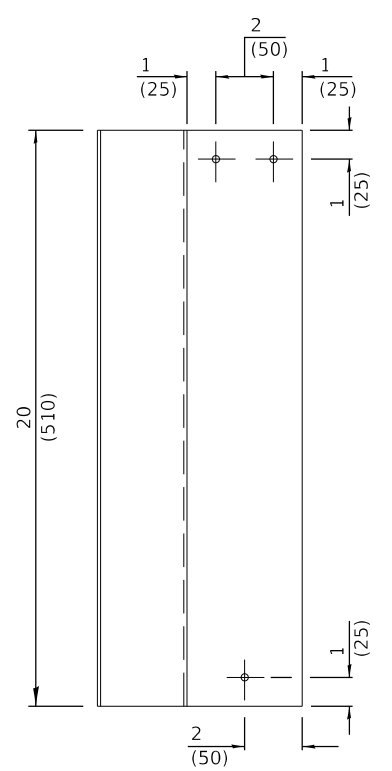

ELEVATION

LUMINAIRE NUMBERING DECAL BRACKET MOUNTING DETAIL

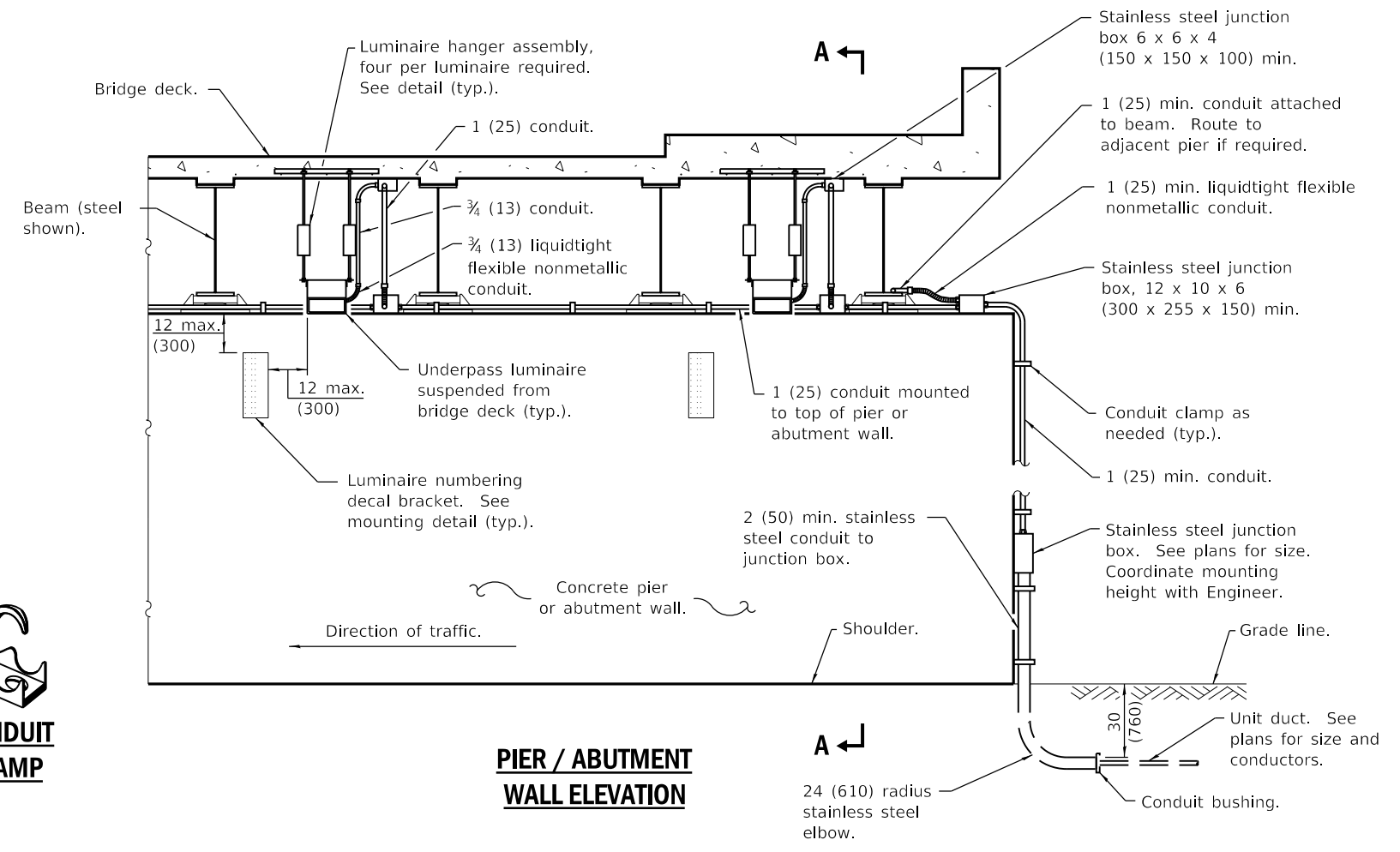
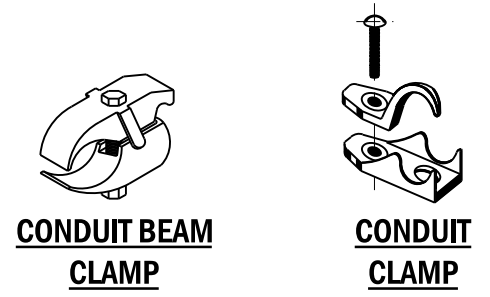

PIER / ABUTMENT WALL ELEVATION

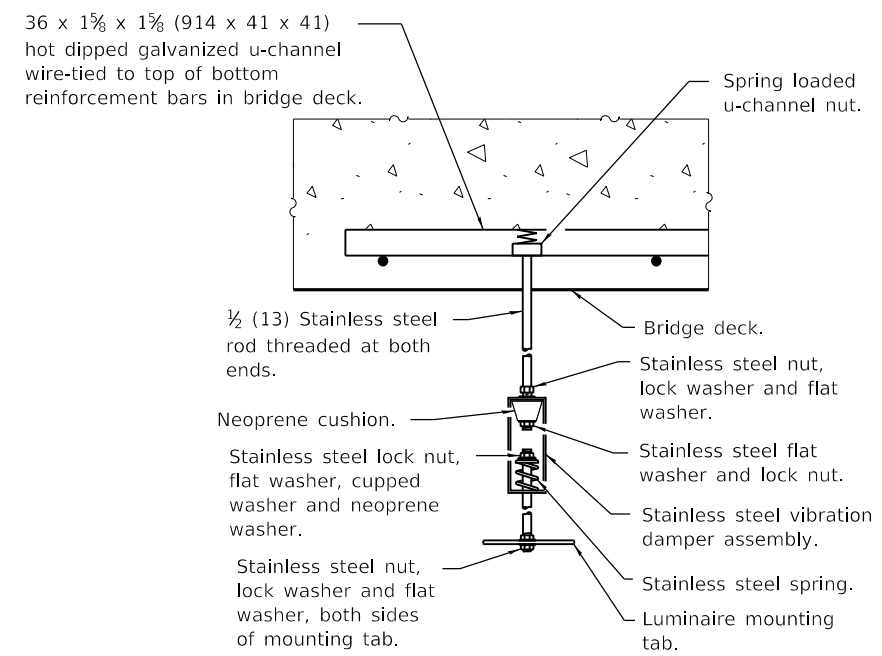

LUMINAIRE HANGER ASSEMBLY DETAIL

GENERAL NOTES

- See plans for underpass luminaire locations.
- Underpass luminaires shall be centered between beams unless otherwise directed by the Engineer.
- Optics of underpass luminaires shall be installed 1 (25) above the bottom of the beams with no parts of the luminaire or attached conduit below the beams.
- Rigid conduit may be used in lieu of flexible conduit.
- Stainless steel conduit shall be used beneath any openings in the bridge deck.
- Branch circuits to luminaires shown routed from underground. Branch circuits may also be routed from bridge parapet above.
- All dimensions are in inches (millimeters) unless otherwise shown.

Illinois Department of Transportation

PASSED April 1, 2016

ENGINEER OF PRELIMINARY ENGINEERING

APPROVED April 1, 2016

ENGINEER OF DESIGN AND ENVIRONMENT

ISSUED 1-1-16

DATE	REVISIONS
4-1-16	New standard.

UNDERPASS LIGHTING SUSPENDED

STANDARD 821006

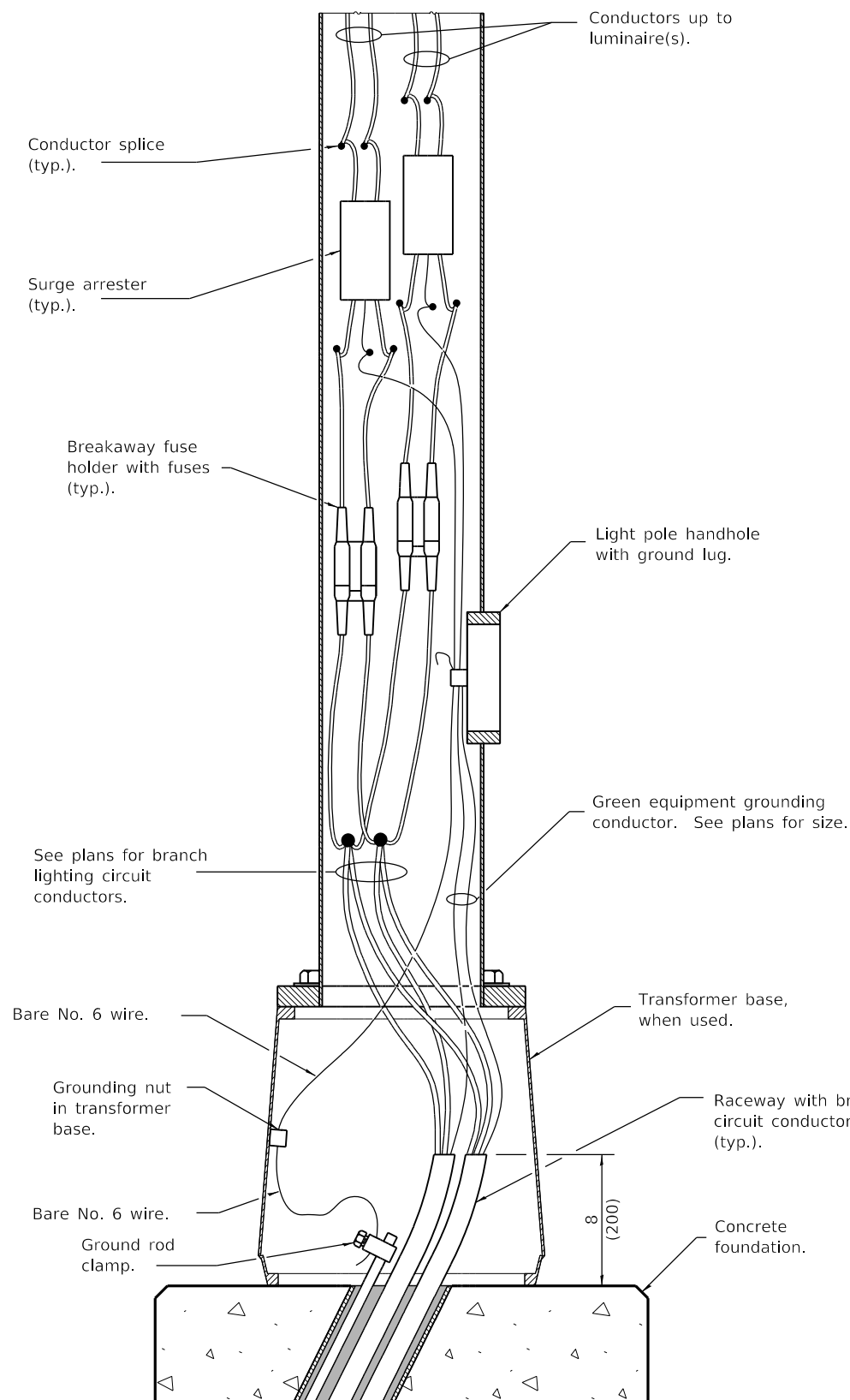

**ELEVATION AT POLE BASE
WITH CONCRETE FOUNDATION**

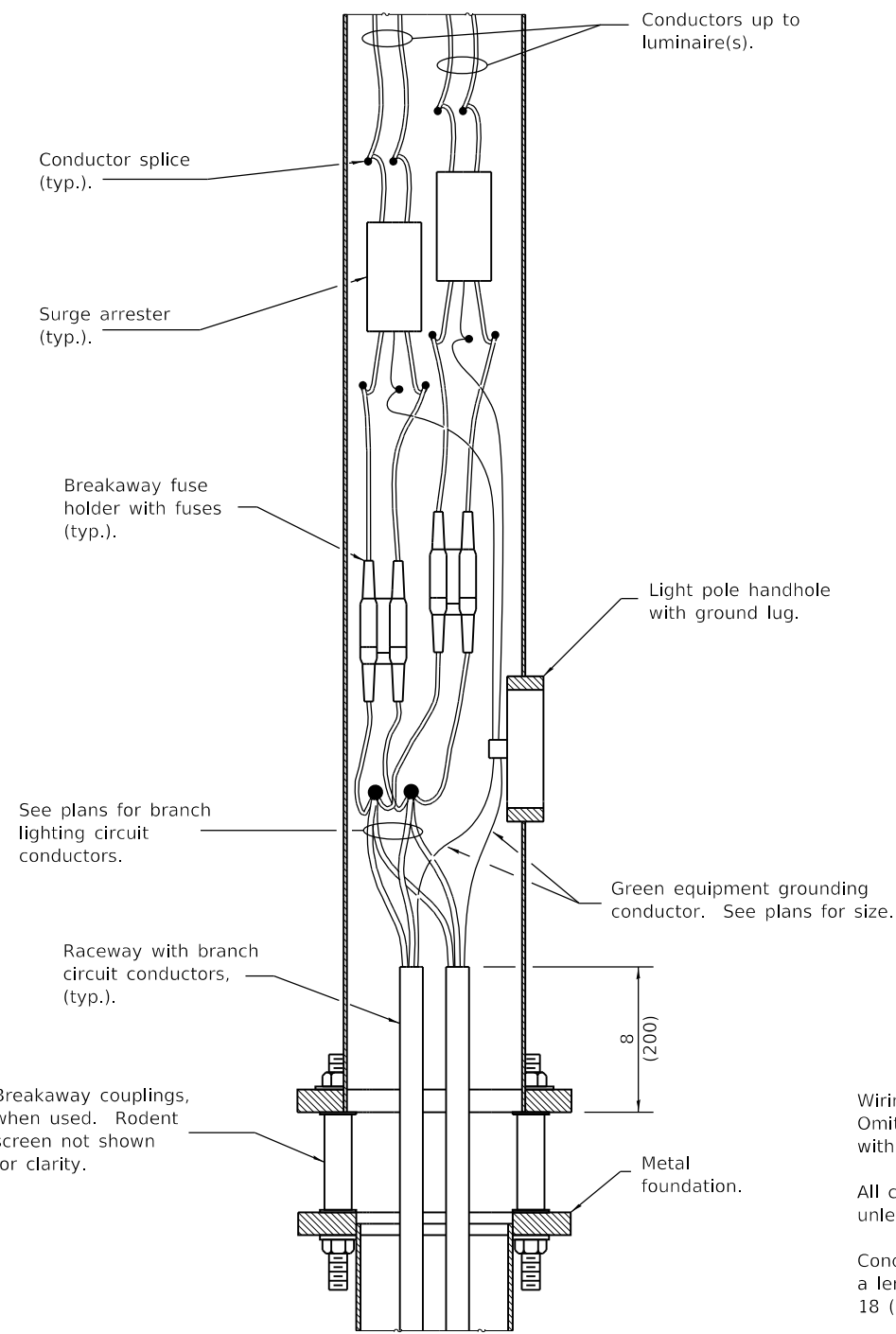

**ELEVATION AT POLE BASE
WITH METAL FOUNDATION**
(Rodent screen not shown)

GENERAL NOTES

Wiring for twin luminaire installation shown. Omit one fuse holder and one surge arrester with connections for single luminaire installation.

All conductors originating in pole shall be No. 10 unless noted otherwise.

Conductors extended into light poles shall be of a length sufficient for splices to be withdrawn 18 (450) out of pole handhole.

Any voids in the foundation shall be filled with fine aggregate.

See Standard 836001 for Light Pole Foundation and ground rod.

All dimensions are in inches (millimeters) unless otherwise shown.

DATE	REVISIONS
1-1-17	Renamed standard.
1-1-15	Changed 'protector' to 'arrester'.

**LUMINAIRE WIRING
IN POLE**

STANDARD 821101-02

Illinois Department of Transportation

PASSED January 1, 2017

ENGINEER OF PRELIMINARY ENGINEERING

APPROVED January 1, 2017

ENGINEER OF DESIGN AND ENVIRONMENT

ISSUED 1-1-14

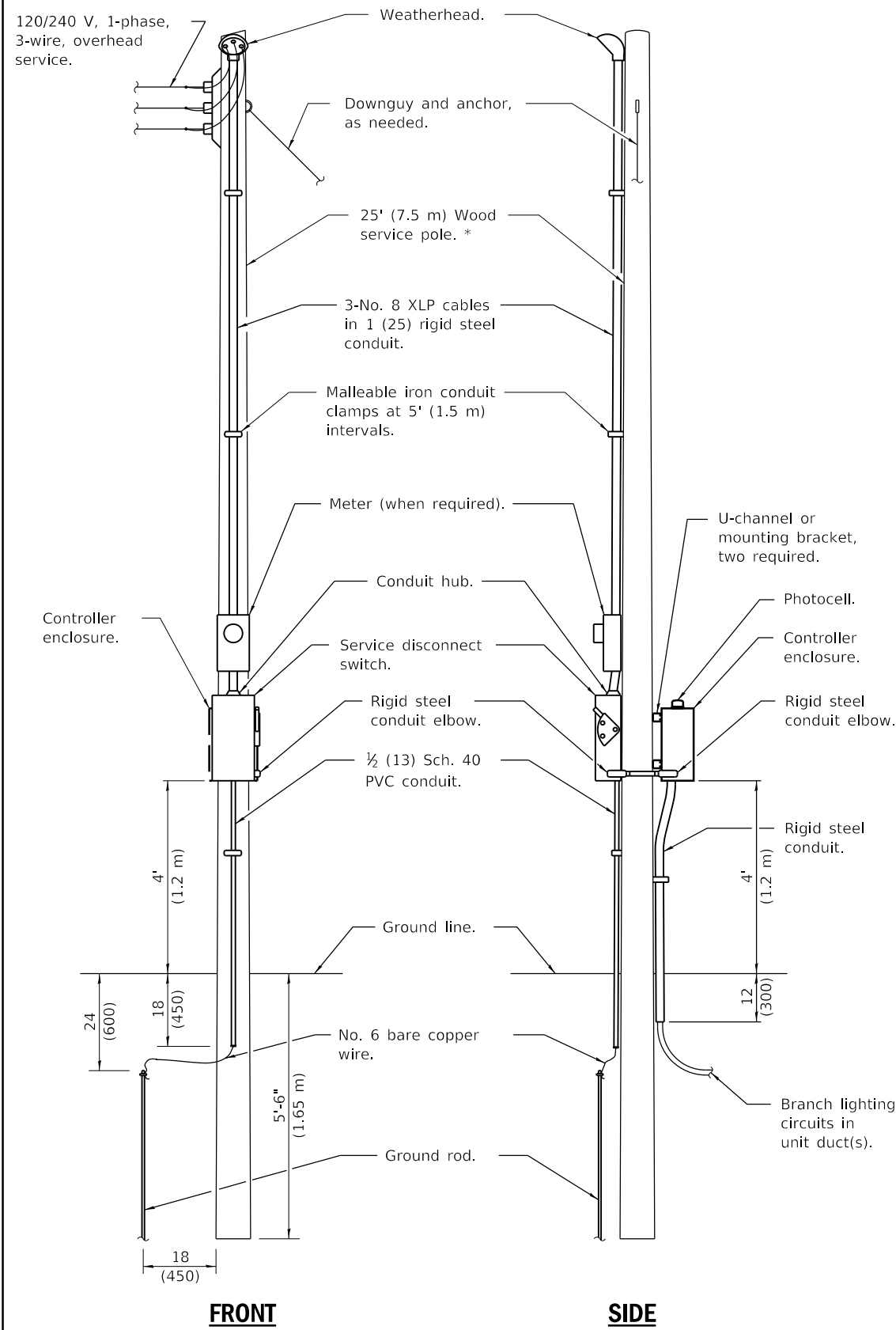

FRONT

SIDE

ELECTRIC SERVICE INSTALLATION

(Typical overhead service shown. Cut pole off for underground service and treat cut surface with preservative. Consult utility company standards for exact requirements.)
 * Size larger as needed.

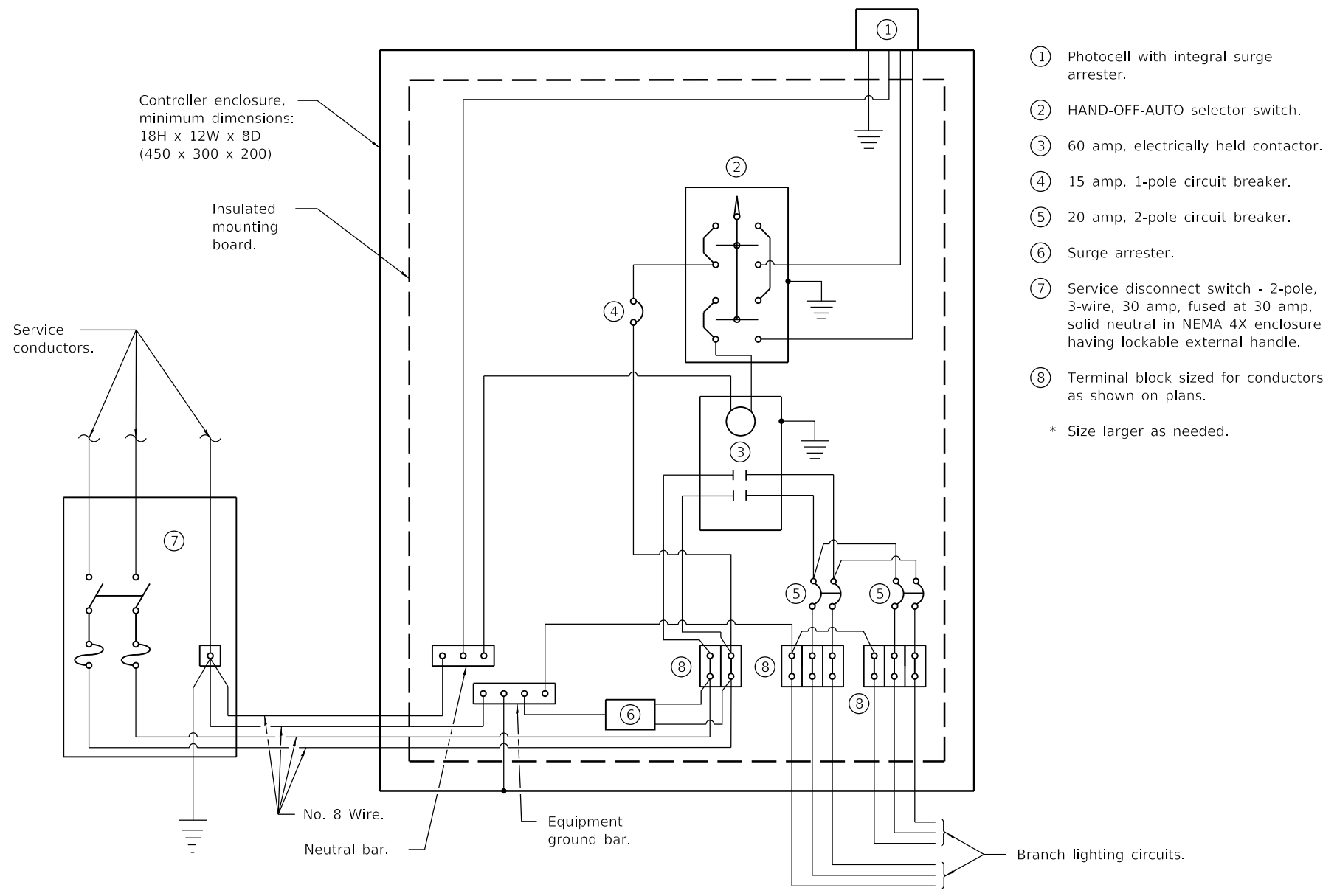

CONTROL SCHEMATIC

- ① Photocell with integral surge arrester.
 - ② HAND-OFF-AUTO selector switch.
 - ③ 60 amp, electrically held contactor.
 - ④ 15 amp, 1-pole circuit breaker.
 - ⑤ 20 amp, 2-pole circuit breaker.
 - ⑥ Surge arrester.
 - ⑦ Service disconnect switch - 2-pole, 3-wire, 30 amp, fused at 30 amp, solid neutral in NEMA 4X enclosure having lockable external handle.
 - ⑧ Terminal block sized for conductors as shown on plans.
- * Size larger as needed.

GENERAL NOTES

Provide 12x9x1 (305x225x25) watertight pouch mounted inside controller door with as-built plans and schematics.

Provide engraved nameplate on front of enclosure reading "LIGHTING".

Enclosure shall be mounted to pole with pole-bands and lag-bolts.

Work pad not shown.

All dimensions are in inches (millimeters) unless otherwise shown.

Illinois Department of Transportation

PASSED January 1, 2019
ME Reppelt
 ELECTRICAL AND MECHANICAL UNIT CHIEF

APPROVED January 1, 2019
J. E. ...
 ENGINEER OF DESIGN AND ENVIRONMENT

ISSUED 1-1-10

DATE	REVISIONS
1-1-19	Replaced ** note with new note regarding consulting utility company standards for installation.
4-1-16	Corrected connection at terminal block.

**LIGHTING CONTROLLER
 POLE MOUNTED, 240V**

(Sheet 1 of 2)

STANDARD 825001-04

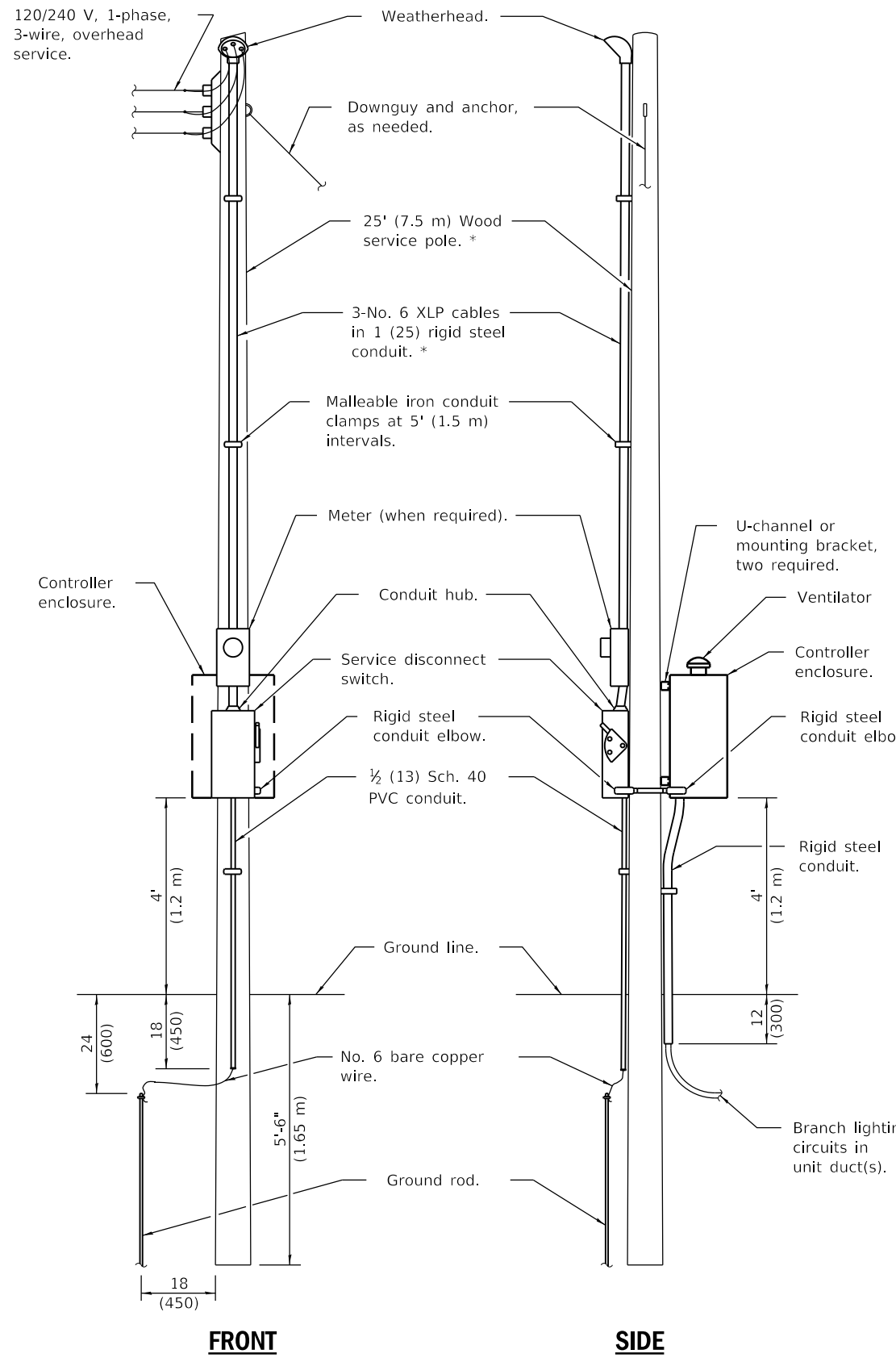

FRONT **SIDE**
ELECTRIC SERVICE INSTALLATION

(Typical overhead service shown. Cut pole off for underground service and treat cut surface with preservative. Consult utility company standards for exact requirements.)
*Size larger as needed.

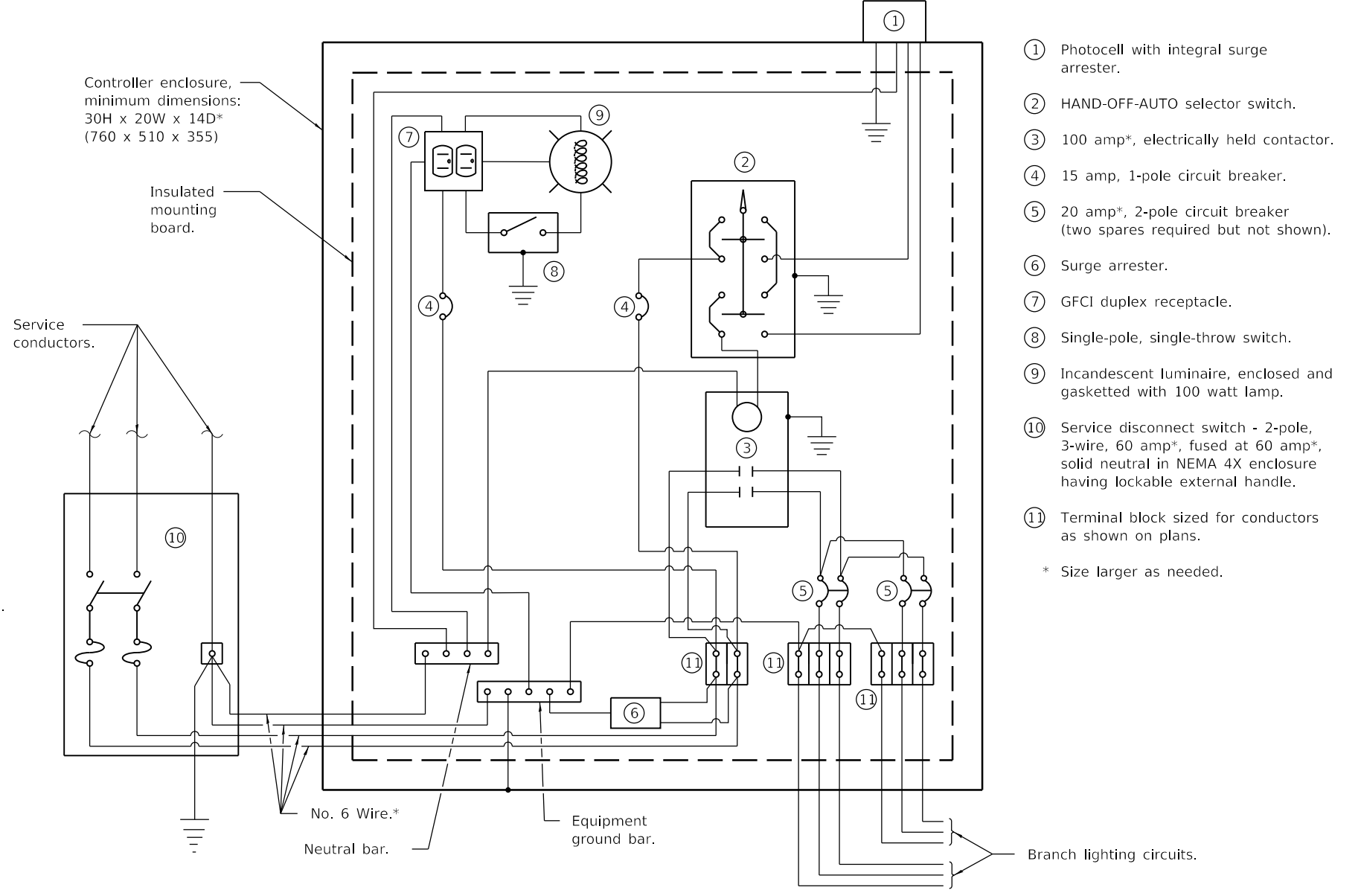

CONTROL SCHEMATIC

- ① Photocell with integral surge arrester.
- ② HAND-OFF-AUTO selector switch.
- ③ 100 amp*, electrically held contactor.
- ④ 15 amp, 1-phase circuit breaker.
- ⑤ 20 amp*, 2-pole circuit breaker (two spares required but not shown).
- ⑥ Surge arrester.
- ⑦ GFCI duplex receptacle.
- ⑧ Single-pole, single-throw switch.
- ⑨ Incandescent luminaire, enclosed and gasketed with 100 watt lamp.
- ⑩ Service disconnect switch - 2-pole, 3-wire, 60 amp*, fused at 60 amp*, solid neutral in NEMA 4X enclosure having lockable external handle.
- ⑪ Terminal block sized for conductors as shown on plans.

* Size larger as needed.

Illinois Department of Transportation

PASSED January 1, 2019
ME Reppelt
ELECTRICAL AND MECHANICAL UNIT CHIEF

APPROVED January 1, 2019
J. E. ...
ENGINEER OF DESIGN AND ENVIRONMENT

ISSUED 1-1-10

LIGHTING CONTROLLER
POLE MOUNTED, 240V

(Sheet 2 of 2)

STANDARD 825001-04

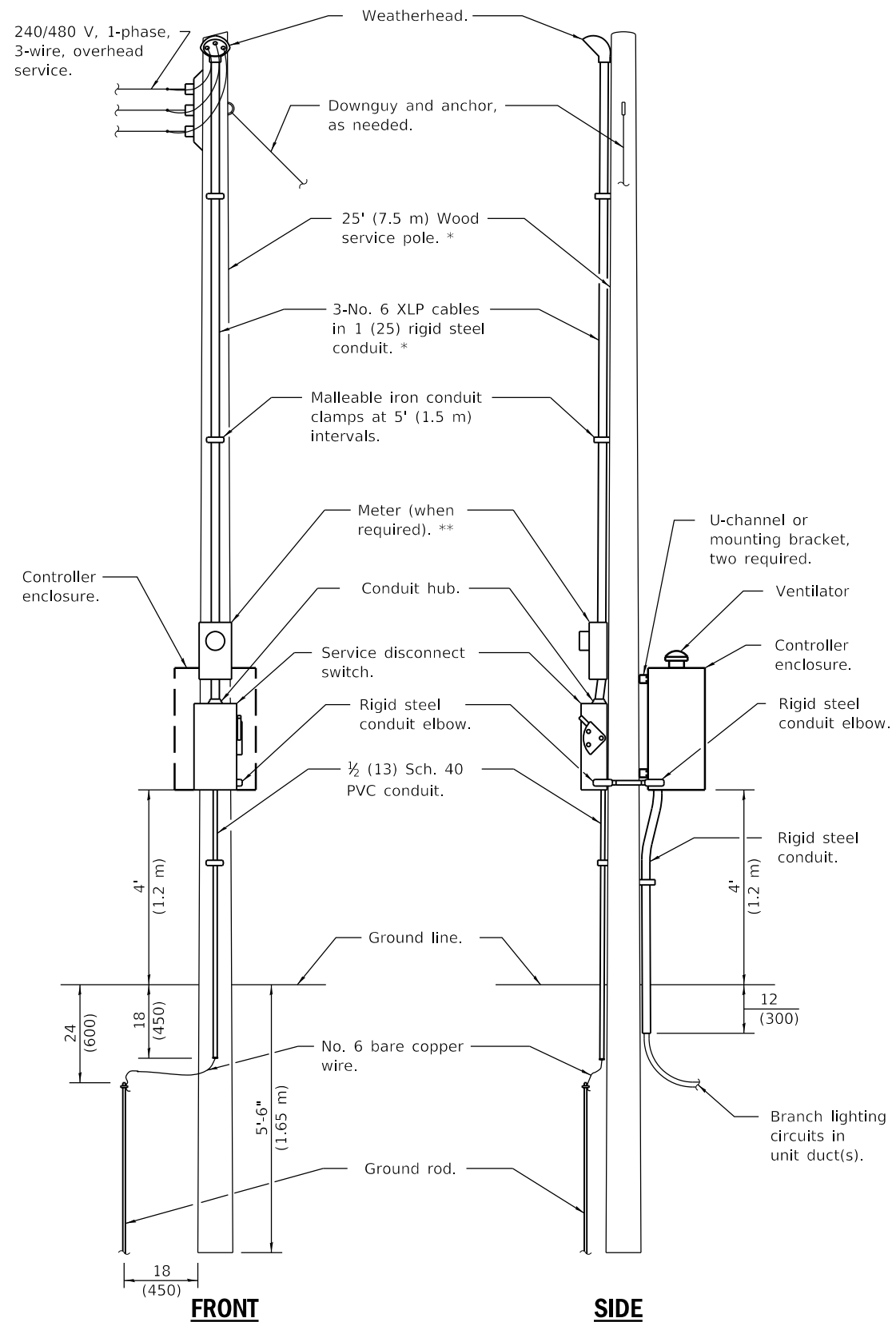

ELECTRIC SERVICE INSTALLATION

(Typical overhead service shown. Cut pole off for underground service and treat cut surface with preservative. Consult utility company standards for exact requirements.)
 * Size larger as needed.
 ** When cold sequencing is required, provide a meter disconnect switch as directed by Utility Company.

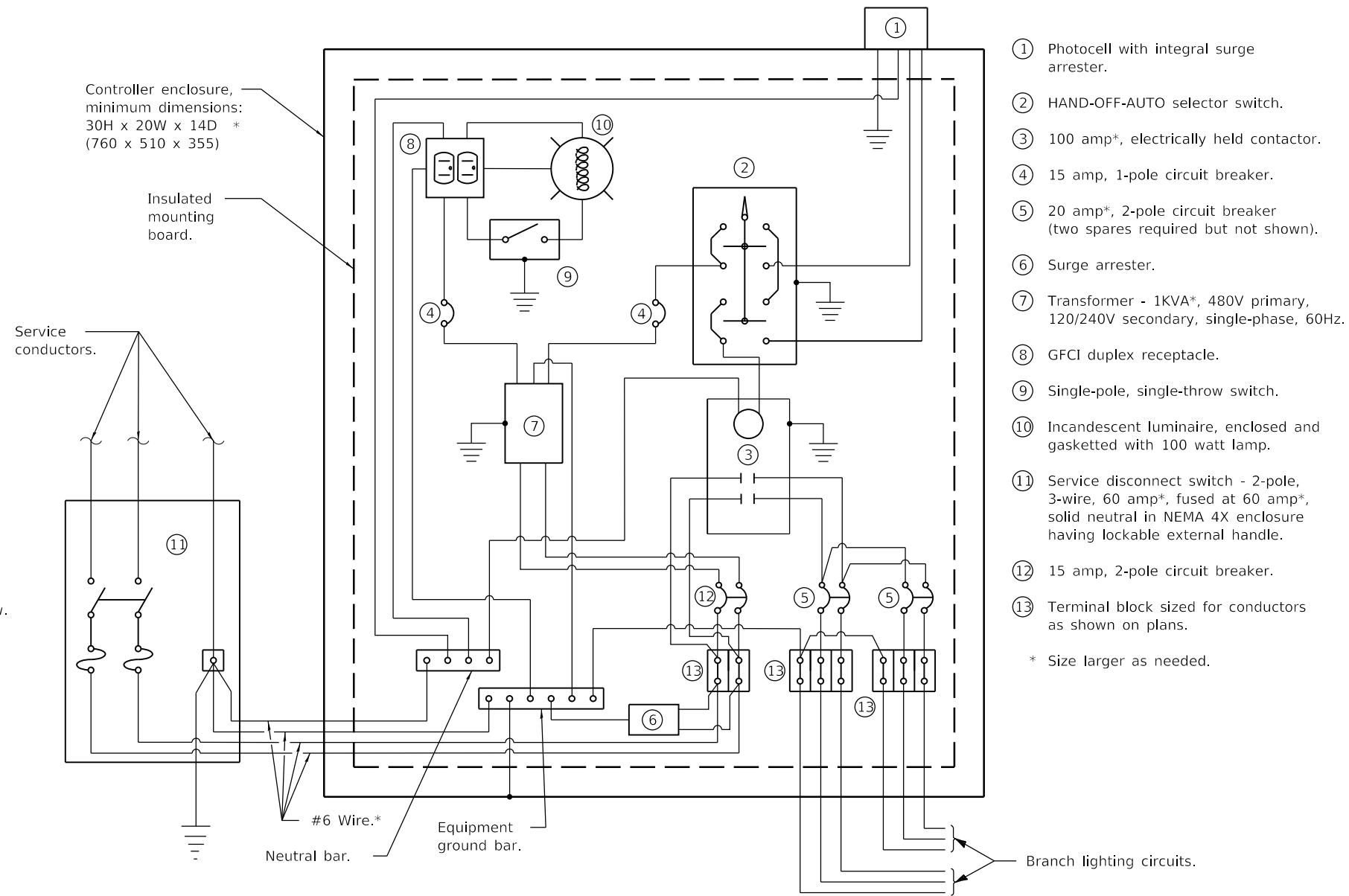

CONTROL SCHEMATIC

- ① Photocell with integral surge arrester.
 - ② HAND-OFF-AUTO selector switch.
 - ③ 100 amp*, electrically held contactor.
 - ④ 15 amp, 1-pole circuit breaker.
 - ⑤ 20 amp*, 2-pole circuit breaker (two spares required but not shown).
 - ⑥ Surge arrester.
 - ⑦ Transformer - 1KVA*, 480V primary, 120/240V secondary, single-phase, 60Hz.
 - ⑧ GFCI duplex receptacle.
 - ⑨ Single-pole, single-throw switch.
 - ⑩ Incandescent luminaire, enclosed and gasketed with 100 watt lamp.
 - ⑪ Service disconnect switch - 2-pole, 3-wire, 60 amp*, fused at 60 amp*, solid neutral in NEMA 4X enclosure having lockable external handle.
 - ⑫ 15 amp, 2-pole circuit breaker.
 - ⑬ Terminal block sized for conductors as shown on plans.
- * Size larger as needed.

GENERAL NOTES

Provide 12x9x1 (305x225x25) watertight pouch mounted inside controller door with as-built plans and schematics.

Provide engraved nameplate on front of enclosure reading "LIGHTING".

Enclosure shall be mounted to pole with pole-bands and lag-bolts.

Work pad not shown.

All dimensions are in inches (millimeters) unless otherwise shown.

Illinois Department of Transportation

PASSED January 1, 2019

ME Reppelt
ELECTRICAL AND MECHANICAL UNIT CHIEF

APPROVED January 1, 2019

J. E. ...
ENGINEER OF DESIGN AND ENVIRONMENT

ISSUED 1-1-10

DATE	REVISIONS
1-1-19	Replaced ** note with new note regarding utility company standards. Made *** the ** note.
1-1-15	Added note ⑬.

**LIGHTING CONTROLLER
POLE MOUNTED, 480V**

STANDARD 825006-03

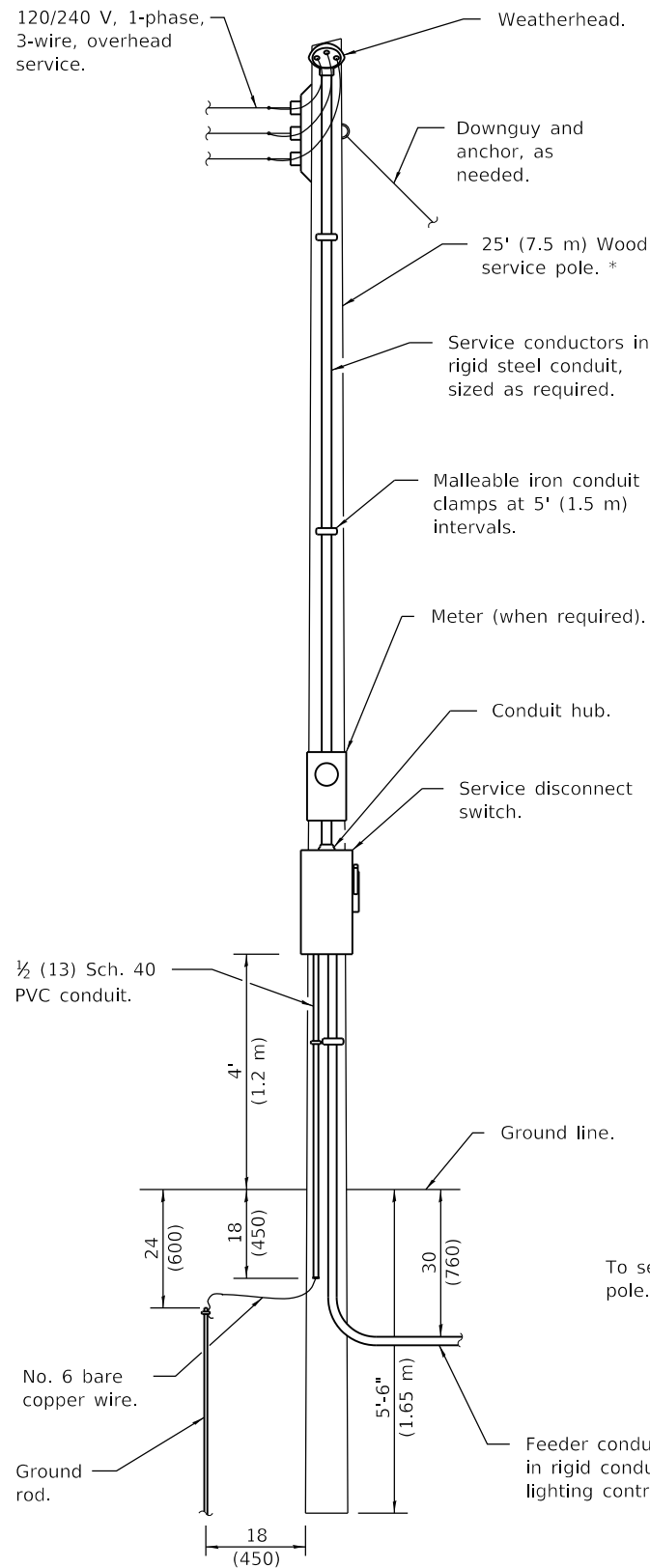

ELECTRIC SERVICE INSTALLATION

(Typical overhead service shown. Cut pole off for underground service and treat cut surface with preservative. Consult utility company standards for exact requirements.)
 * Size larger as needed.

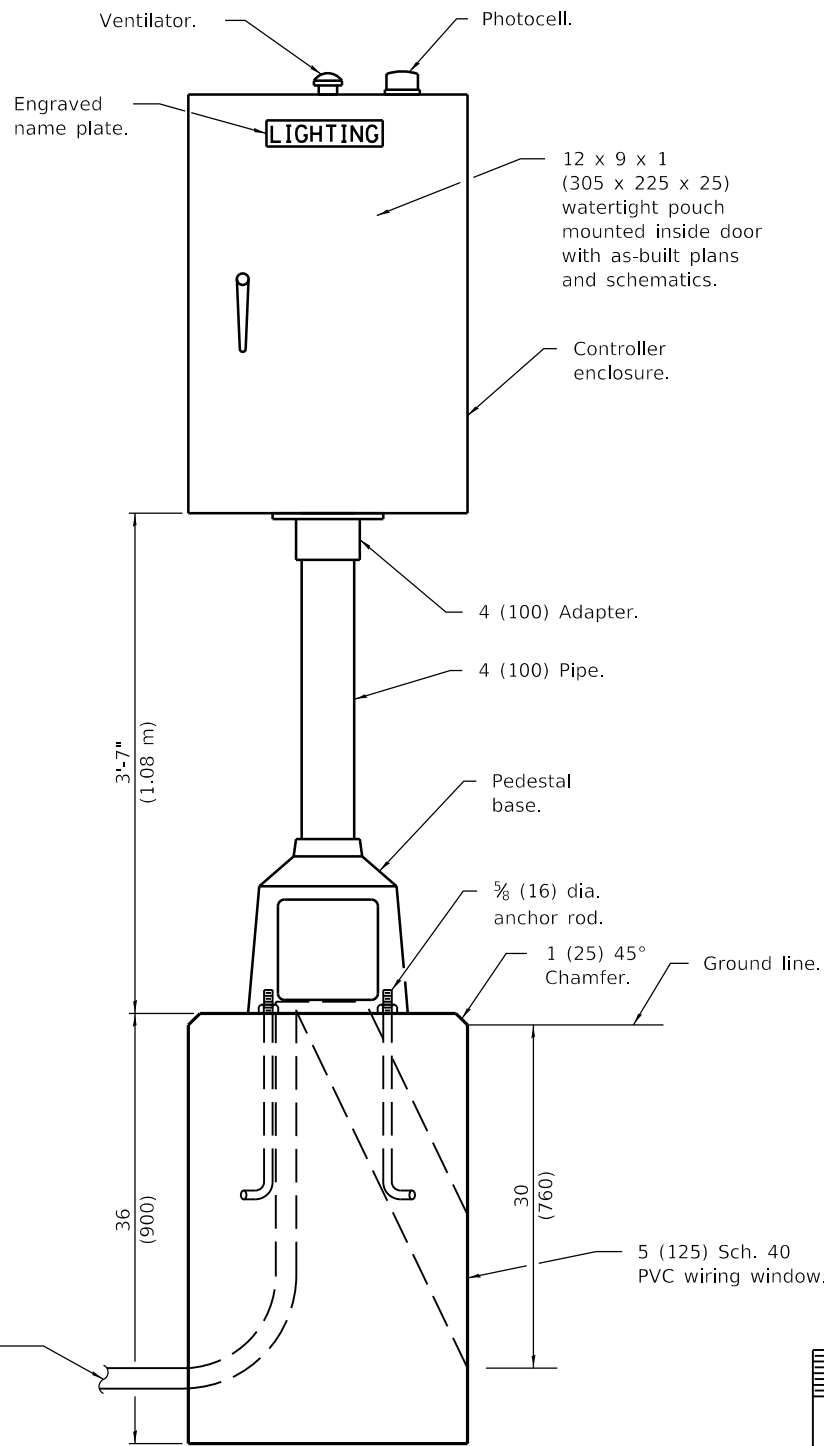

LIGHTING CONTROLLER

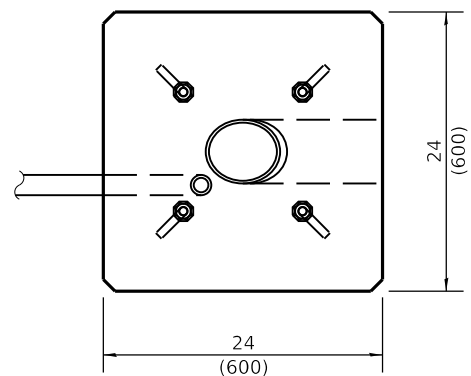

FOUNDATION (PLAN)

(Work pad not shown.)

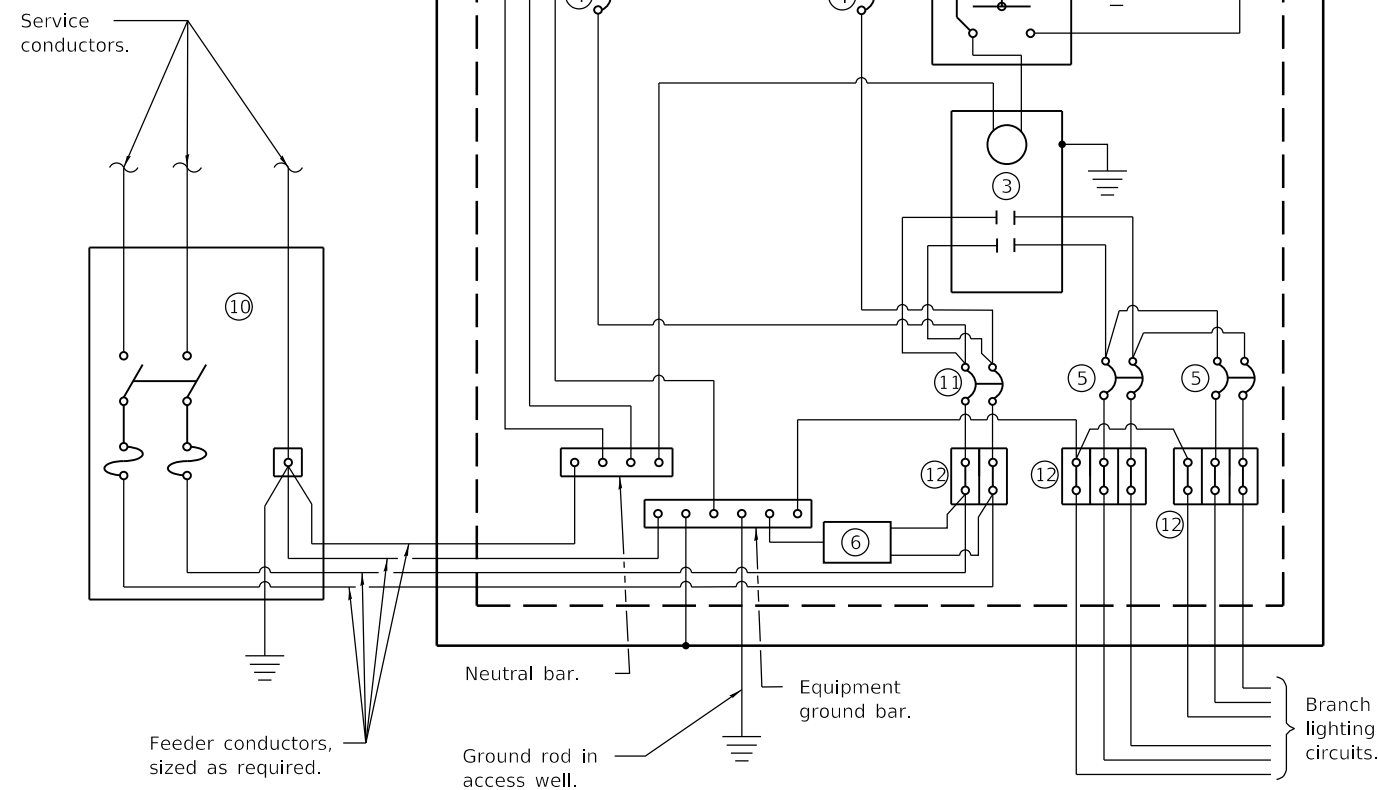

CONTROL SCHEMATIC

- ① Photocell with integral surge arrester.
 - ② HAND-OFF-AUTO selector switch.
 - ③ 100 amp*, electrically held contactor.
 - ④ 15 amp, 1-pole circuit breaker.
 - ⑤ 20 amp*, 2-pole circuit breaker (two spares required but not shown).
 - ⑥ Surge arrester.
 - ⑦ GFCI duplex receptacle.
 - ⑧ Single-pole, single-throw switch.
 - ⑨ Incandescent luminaire, enclosed and gasketed with 100 watt lamp.
 - ⑩ Service disconnect switch - 2-pole, 3-wire, 60 amp*, fused at 60 amp*, solid neutral in NEMA 4X enclosure having lockable external handle.
 - ⑪ 60 amp*, 2-pole circuit breaker.
 - ⑫ Terminal block sized for conductors as shown on plans.
- * Size larger as needed.

All dimensions are in inches (millimeters) unless otherwise shown.

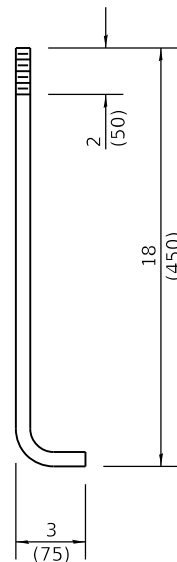

ANCHOR ROD DETAIL

DATE	REVISIONS
1-1-19	Replaced ** note with new note regarding consulting utility company standards for installation.
1-1-15	Added note ⑫.

**LIGHTING CONTROLLER
PEDESTAL MOUNTED, 240V**

STANDARD 825011-04

Illinois Department of Transportation
 PASSED January 1, 2019
 ME Reppelt
 ELECTRICAL AND MECHANICAL UNIT CHIEF
 APPROVED January 1, 2019
 S. E. C. E.
 ENGINEER OF DESIGN AND ENVIRONMENT

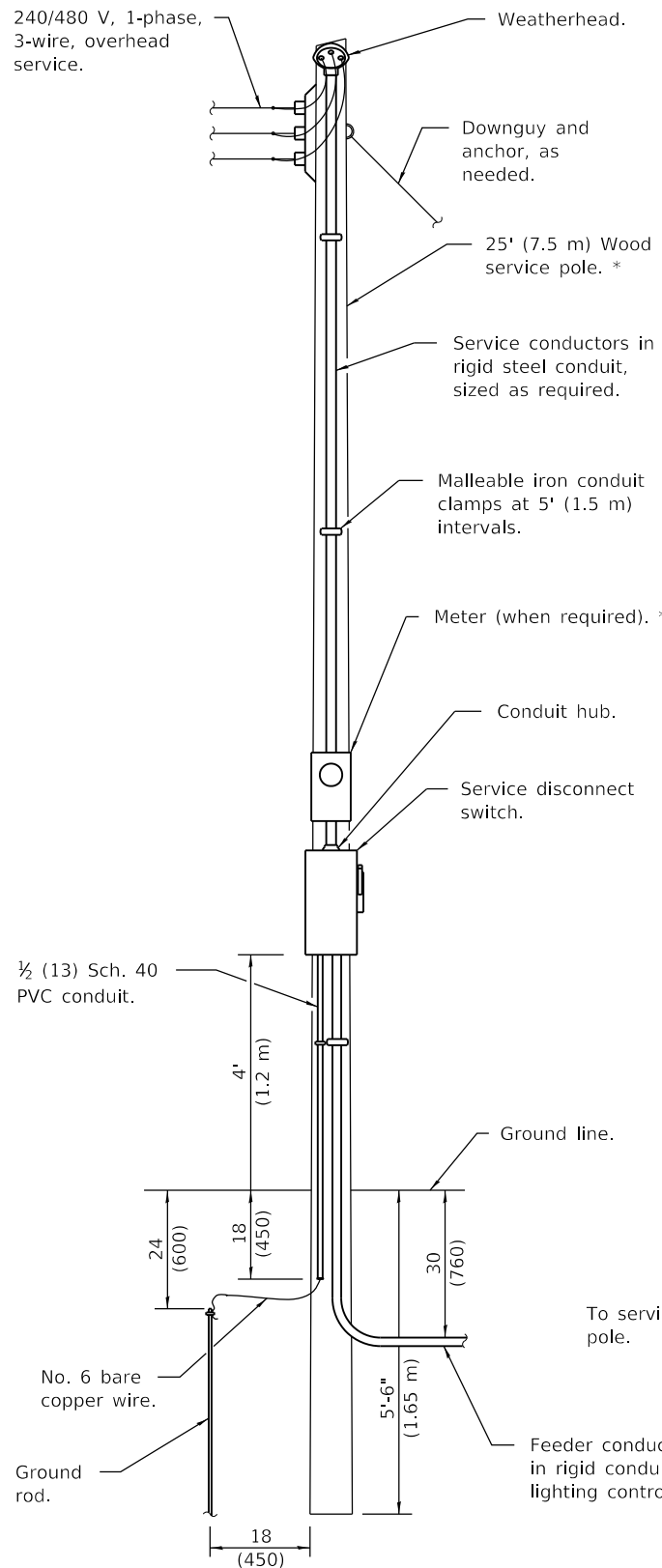

ELECTRIC SERVICE INSTALLATION

(Typical overhead service shown. Cut pole off for underground service and treat cut surface with preservative. Consult utility company standards for exact requirements.)
 *Size larger as needed.
 **When cold sequencing is required, provide a meter disconnect switch as directed by Utility Company.

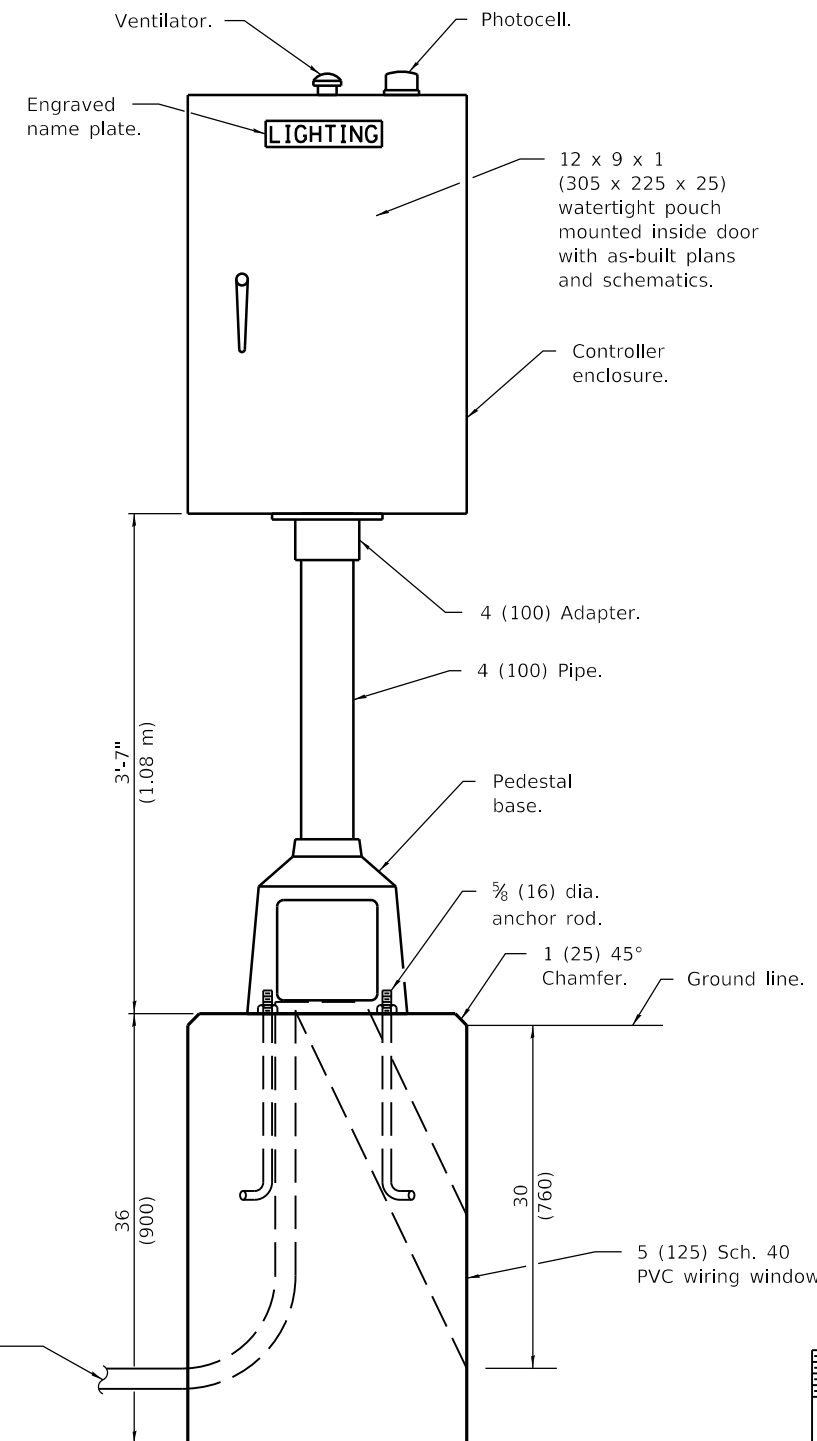

LIGHTING CONTROLLER

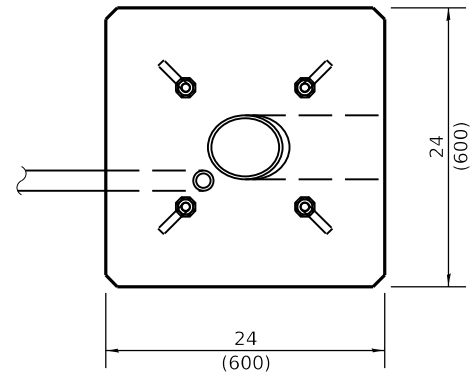

FOUNDATION (PLAN)

(Work pad not shown.)

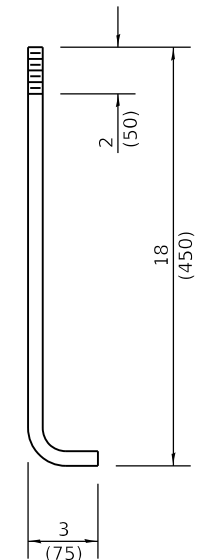

ANCHOR ROD DETAIL

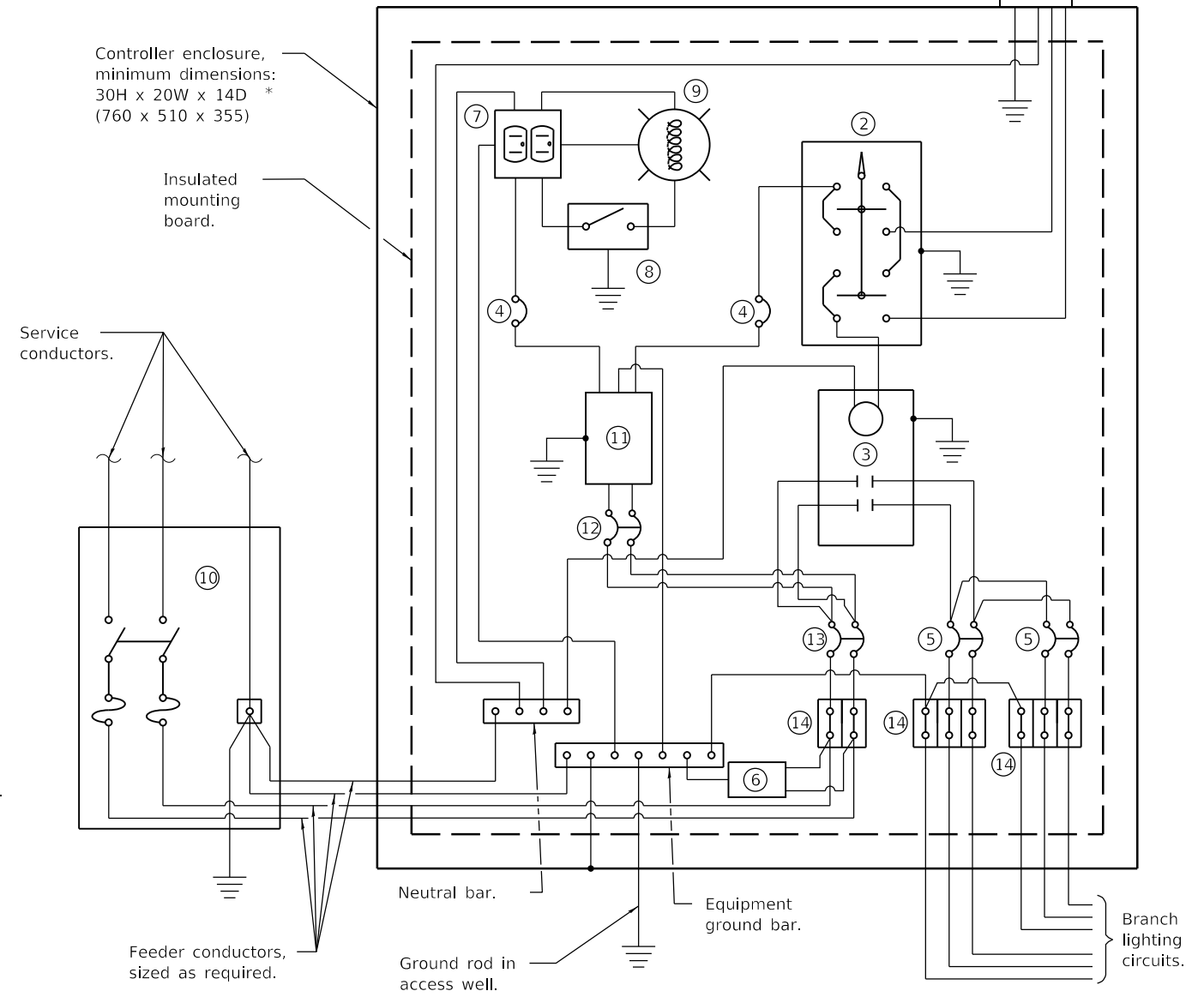

CONTROL SCHEMATIC

- ① Photocell with integral surge arrester.
- ② HAND-OFF-AUTO selector switch.
- ③ 100 amp*, electrically held contactor.
- ④ 15 amp, 1-pole circuit breaker.
- ⑤ 20 amp*, 2-pole circuit breaker (two spares required but not shown).
- ⑥ Surge arrester.
- ⑦ GFCI duplex receptacle.
- ⑧ Single-pole, single-throw switch.
- ⑨ Incandescent luminaire, enclosed and gasketed with 100 watt lamp.
- ⑩ Service disconnect switch - 2-pole, 3-wire, 60 amp*, fused at 60 amp*, solid neutral in NEMA 4X enclosure having lockable external handle.
- ⑪ Transformer - 1KVA*, 480V primary, 120/240V secondary, single-phase, 60Hz.
- ⑫ 15 amp, 2-pole circuit breaker.
- ⑬ 60 amp*, 2-pole circuit breaker.
- ⑭ Terminal block sized for conductors as shown on plans.

* Size larger as needed.

All dimensions are in inches (millimeters) unless otherwise shown.

DATE	REVISIONS
1-1-19	Replaced ** note with new note regarding utility company standards. Made *** the ** note.
1-1-15	Added note ⑭.

**LIGHTING CONTROLLER
PEDESTAL MOUNTED, 480V**

STANDARD 825016-04

Illinois Department of Transportation

PASSED January 1, 2019

ME Reppelt
ELECTRICAL AND MECHANICAL UNIT CHIEF

APPROVED January 1, 2019

J. E. ...
ENGINEER OF DESIGN AND ENVIRONMENT

ISSUED 1-1-19

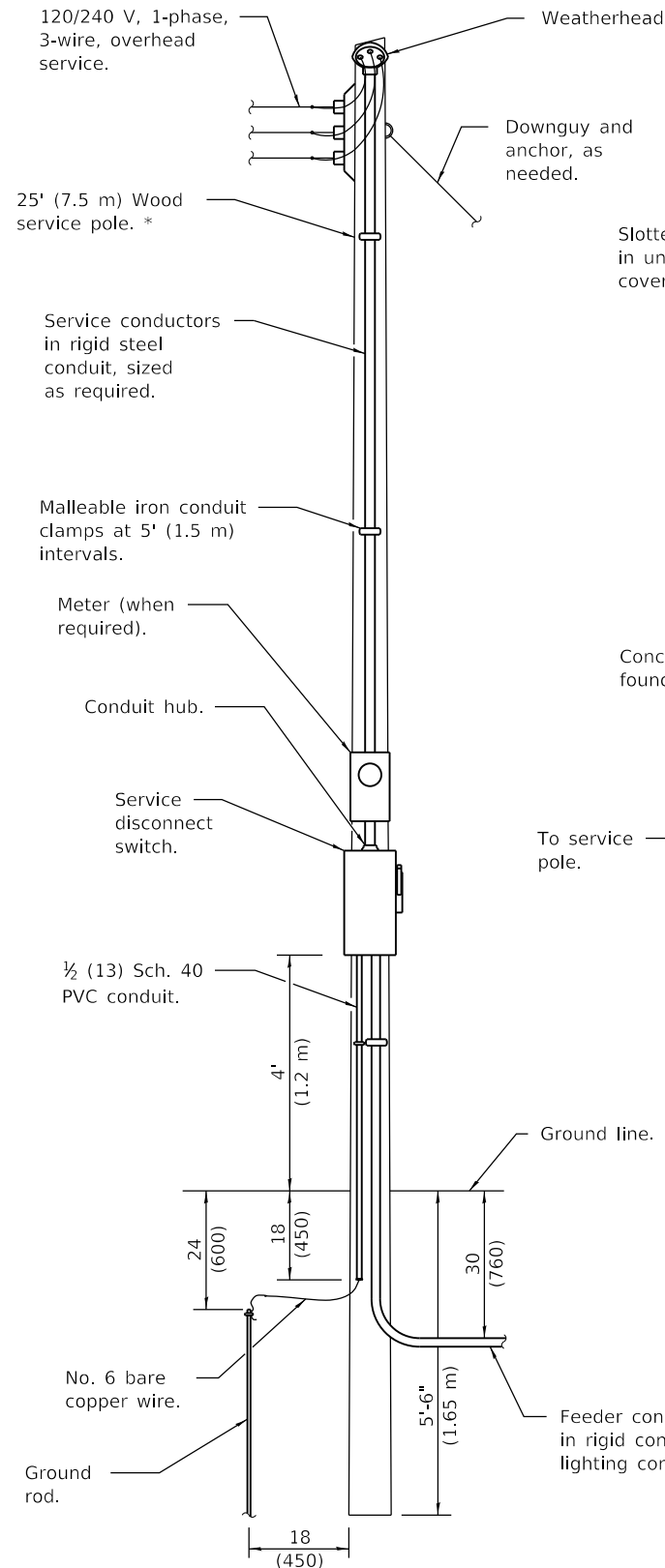

ELECTRIC SERVICE INSTALLATION

(Typical overhead service shown. Cut pole off for underground service and treat cut surface with preservative. Consult utility company standards for exact requirements.)

* Size larger as needed.

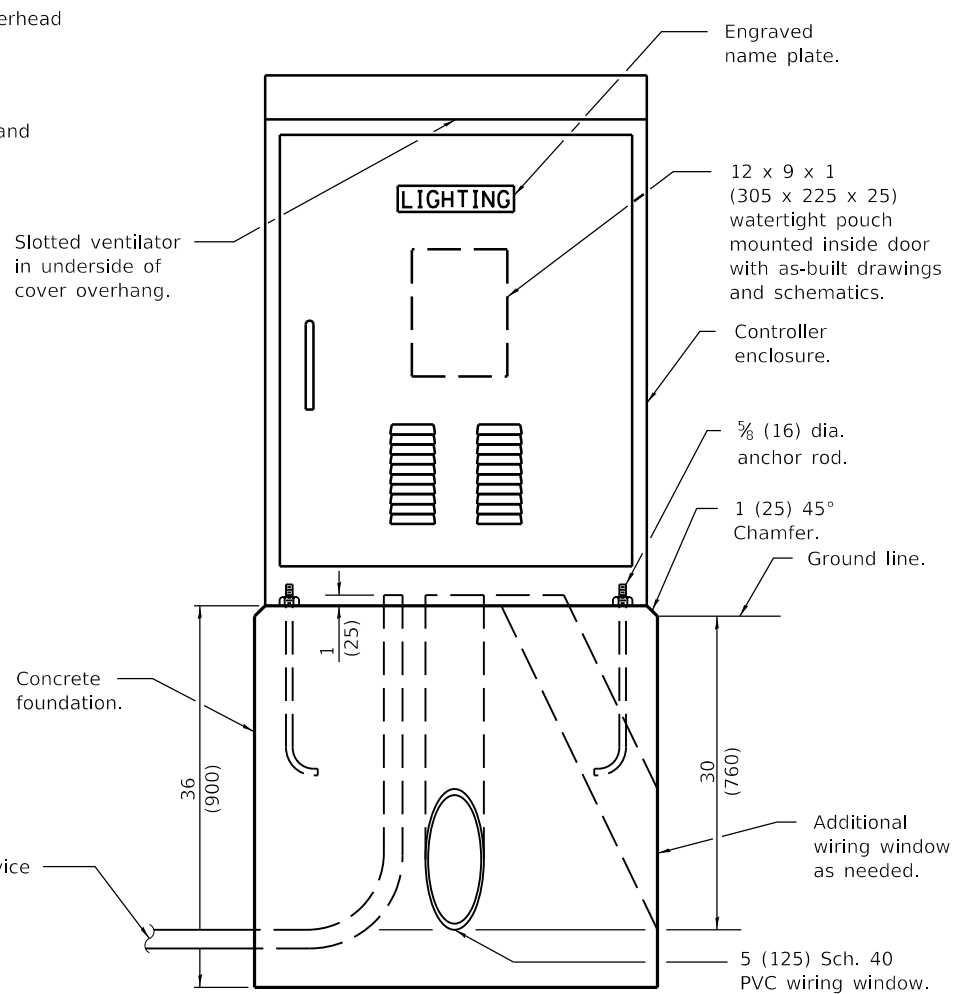

LIGHTING CONTROLLER

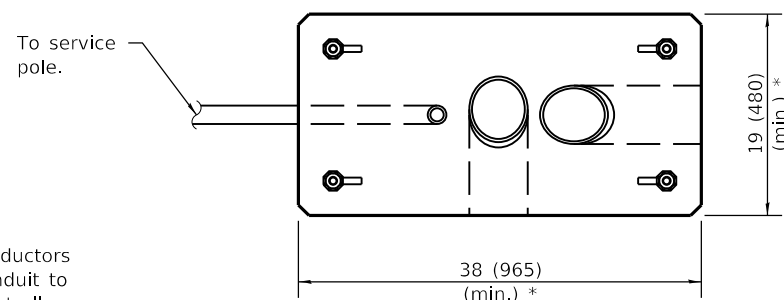

FOUNDATION (PLAN)

(Work pad not shown.)

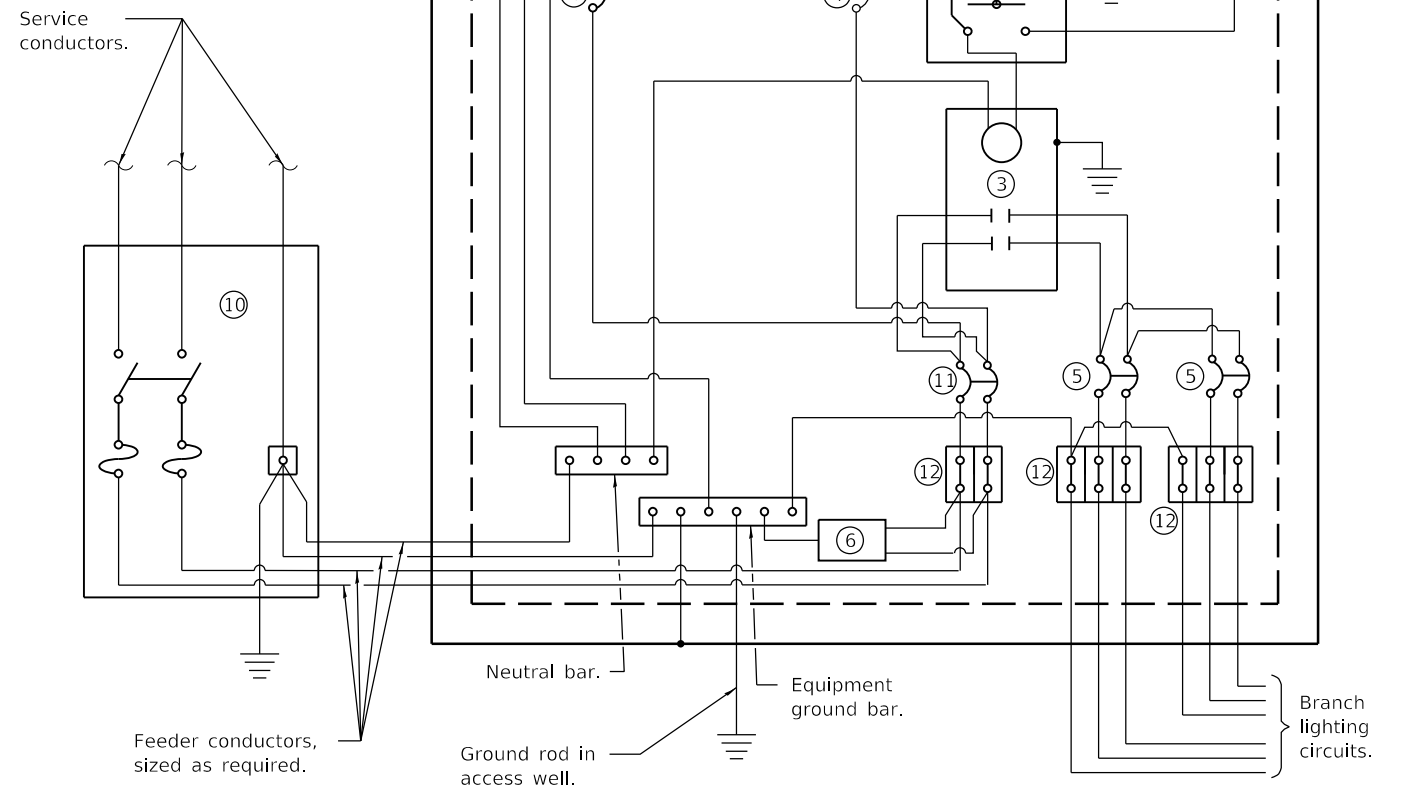

CONTROL SCHEMATIC

- ① Photocell with integral surge arrester.
- ② HAND-OFF-AUTO selector switch.
- ③ 100 amp*, electrically held contactor.
- ④ 15 amp, 1-pole circuit breaker.
- ⑤ 20 amp*, 2-pole circuit breaker (two spares required but not shown).
- ⑥ Surge arrester.
- ⑦ GFCI duplex receptacle.
- ⑧ Single-pole, single-throw switch.
- ⑨ Incandescent luminaire, enclosed and gasketed with 100 watt lamp.
- ⑩ Service disconnect switch - 2-pole, 3-wire, 100 amp*, fused at 100 amp*, solid neutral in NEMA 4X enclosure having lockable external handle.
- ⑪ 100 amp*, 2-pole circuit breaker.
- ⑫ Terminal block sized for conductors as shown on plans.

* Size larger as needed.

All dimensions are in inches (millimeters) unless otherwise shown.

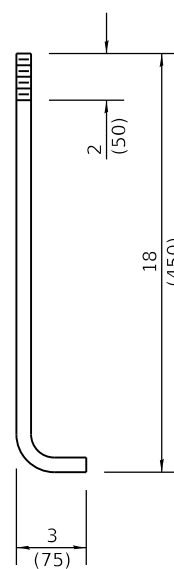

ANCHOR ROD DETAIL

DATE	REVISIONS
1-1-19	Replaced ** note with new note regarding consulting utility company standards for installation.
1-1-15	Added note ⑫.

**LIGHTING CONTROLLER
BASE MOUNTED, 240V**

STANDARD 825021-04

Illinois Department of Transportation

PASSED January 1, 2019

ME Reppelt
ELECTRICAL AND MECHANICAL UNIT CHIEF

APPROVED January 1, 2019

J. E. ...
ENGINEER OF DESIGN AND ENVIRONMENT

ISSUED 01-1-19

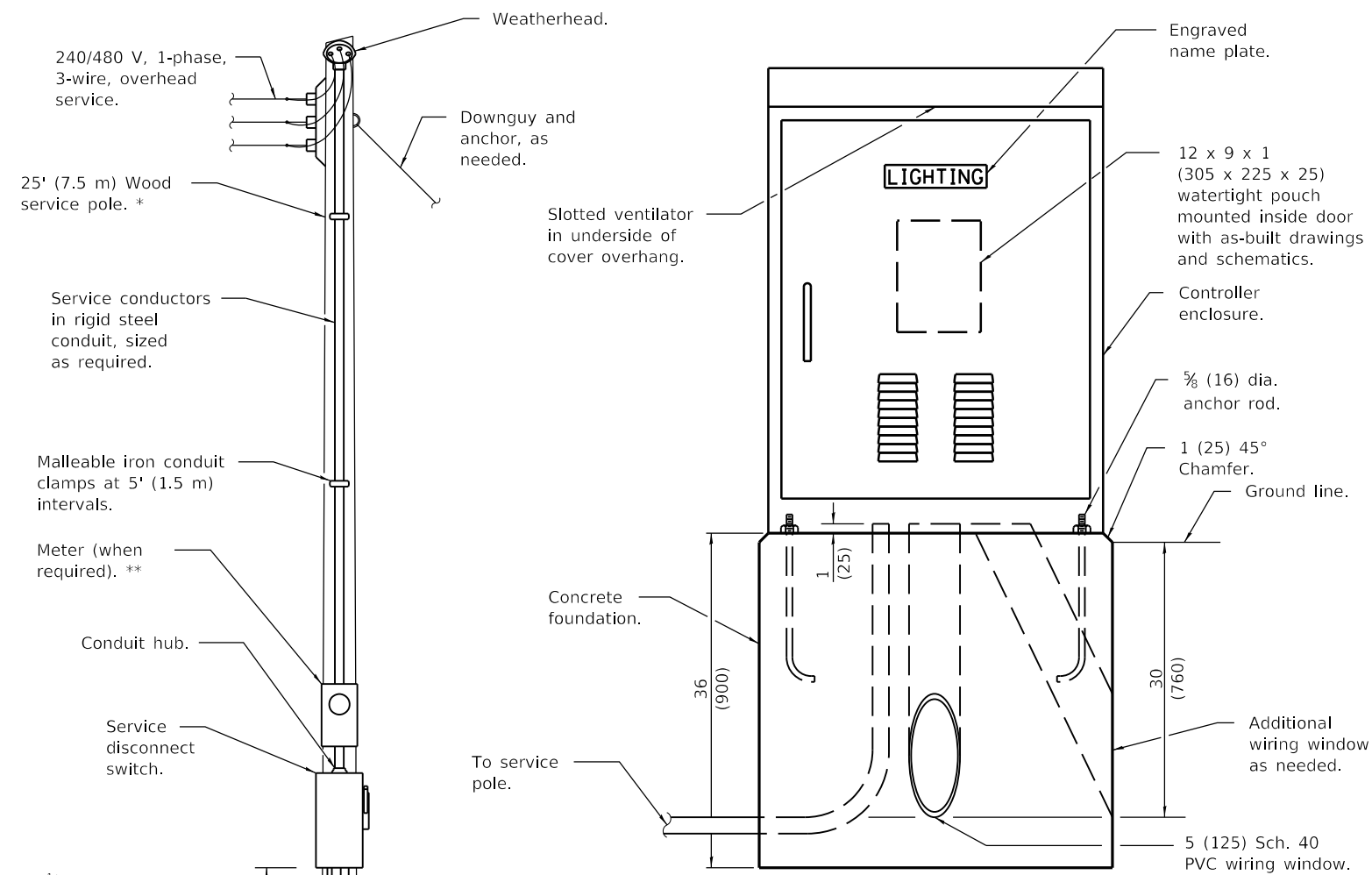

LIGHTING CONTROLLER

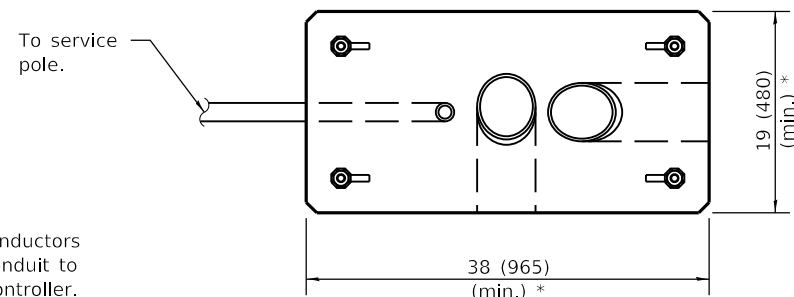

FOUNDATION (PLAN)

(Work pad not shown.)

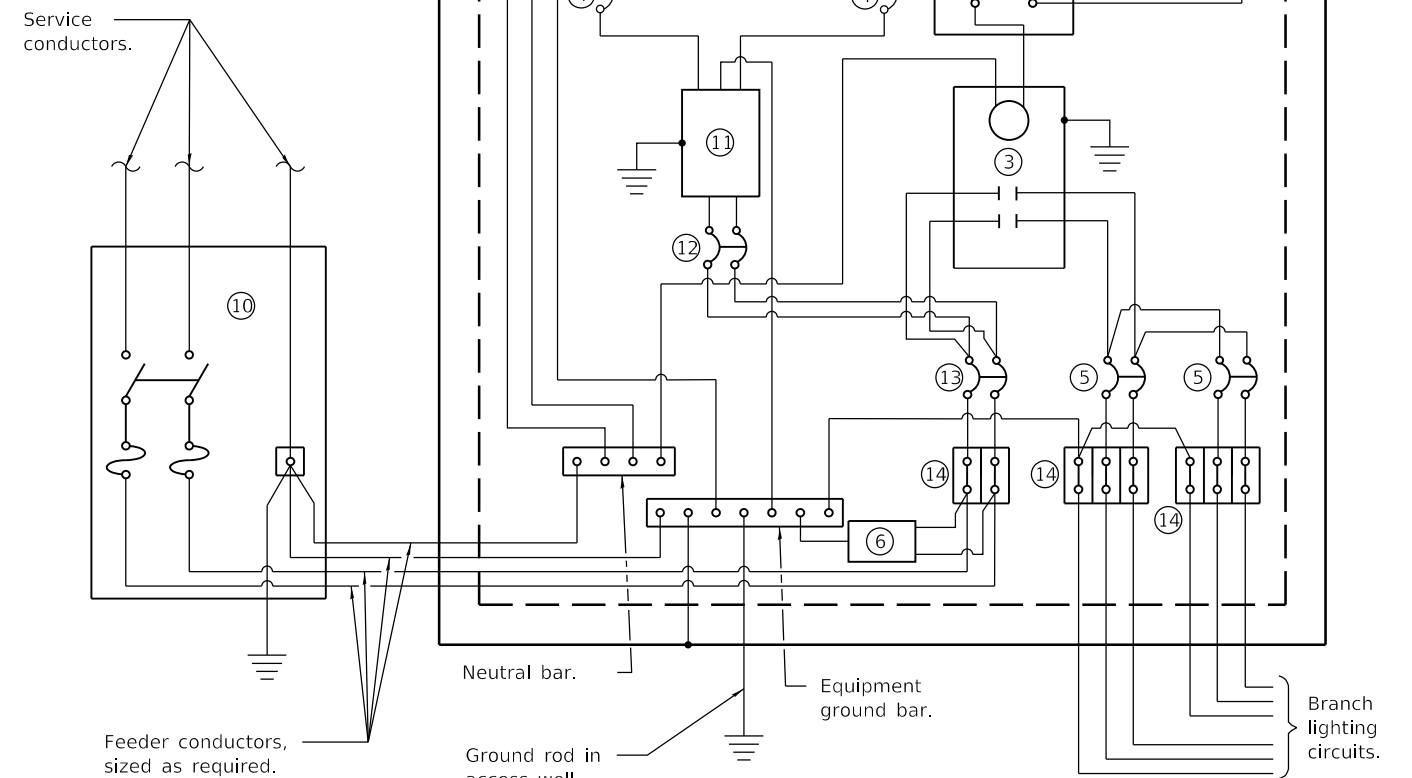

CONTROL SCHEMATIC

- ① Photocell with integral surge arrester.
- ② HAND-OFF-AUTO selector switch.
- ③ 100 amp*, electrically held contactor.
- ④ 15 amp, 1-pole circuit breaker.
- ⑤ 20 amp*, 2-pole circuit breaker (two spares required but not shown).
- ⑥ Surge arrester.
- ⑦ GFCI duplex receptacle.
- ⑧ Single-pole, single-throw switch.
- ⑨ Incandescent luminaire, enclosed and gasketed with 100 watt lamp.
- ⑩ Service disconnect switch - 2-pole, 3-wire, 100 amp*, fused at 100 amp*, solid neutral in NEMA 4X enclosure having lockable external handle.
- ⑪ Transformer - 1KVA*, 480V primary, 120/240V secondary, single-phase, 60Hz.
- ⑫ 15 amp, 2-pole circuit breaker.
- ⑬ 100 amp*, 2-pole circuit breaker.
- ⑭ Terminal block sized for conductors as shown on plans.

* Size larger as needed.

All dimensions are in inches (millimeters) unless otherwise shown.

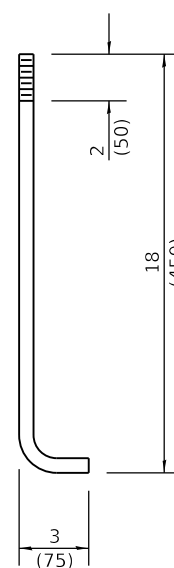

ANCHOR ROD DETAIL

DATE	REVISIONS
1-1-19	Replaced ** note with new note regarding utility company standards. Made *** the ** note.
1-1-15	Added note ⑭.

**LIGHTING CONTROLLER
BASE MOUNTED, 480V**

STANDARD 825026-04

Illinois Department of Transportation

PASSED January 1, 2019

ISSUED 1-1-10

ME Reppelt
ELECTRICAL AND MECHANICAL UNIT CHIEF

APPROVED January 1, 2019

ENGINEER OF DESIGN AND ENVIRONMENT

(Typical overhead service shown. Cut pole off for underground service and treat cut surface with preservative. Consult utility company standards for exact requirements.)

* Size larger as needed.

** When cold sequencing is required, provide a meter disconnect switch as directed by Utility Company.

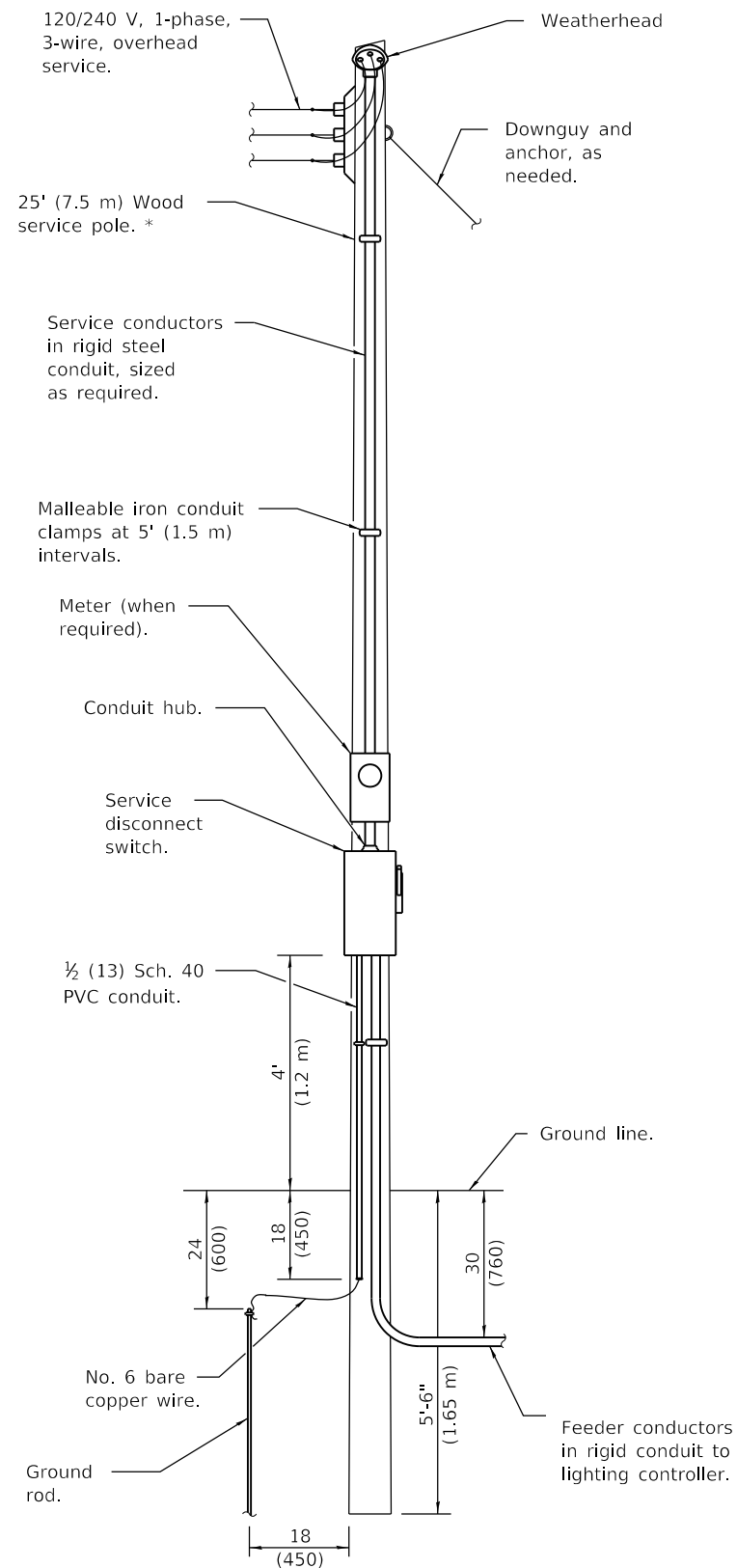

ELECTRIC SERVICE INSTALLATION

(Typical overhead service shown. Cut pole off for underground service and treat cut surface with preservative. Consult utility company standards for exact requirements.)

* Size larger as needed.

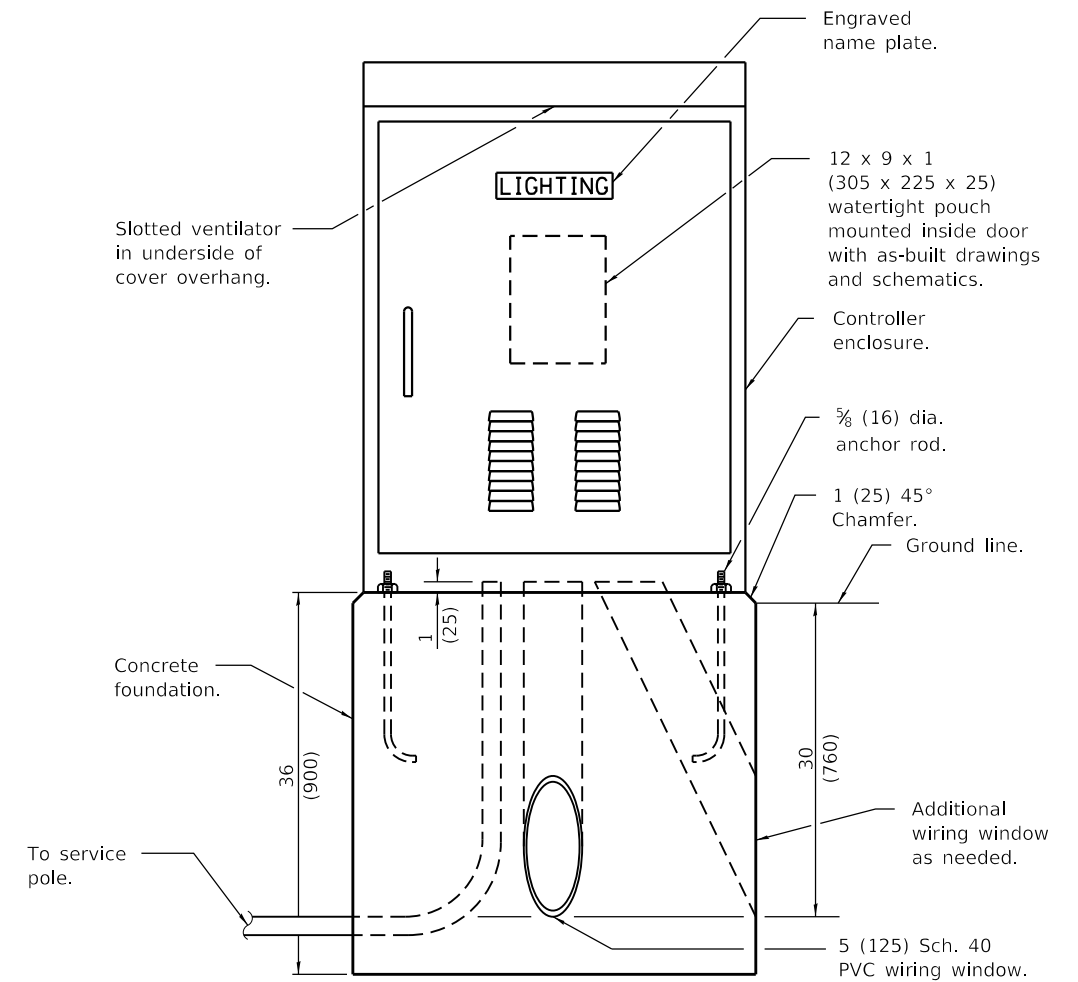

LIGHTING CONTROLLER

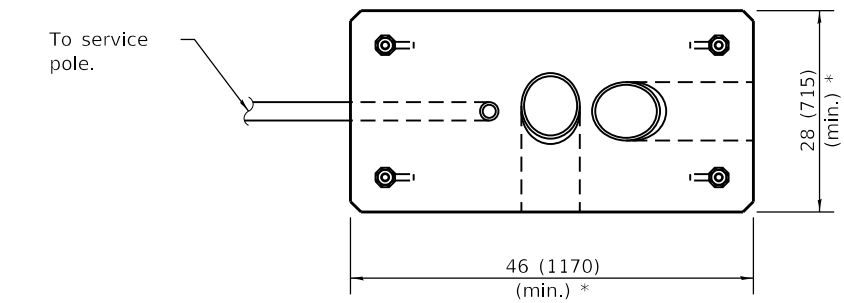

FOUNDATION (PLAN)

(Work pad not shown.)

* Size larger as needed.

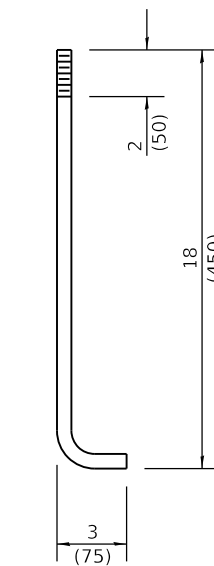

ANCHOR ROD DETAIL

All dimensions are in inches (millimeters) unless otherwise shown.

DATE	REVISIONS
1-1-22	Replaced "Navigation" with "Obstruction Warning" in std title, note ② and Control Schematic.
1-1-19	Replaced ** note with new note regarding consulting utility company standards for installation.

OBSTRUCTION WARNING
LIGHTING CONTROLLER, 240V
 (Sheet 1 of 2)

STANDARD 826001-03

Illinois Department of Transportation

PASSED January 1, 2022
Bernard A. Griffin
 ELECTRICAL AND MECHANICAL UNIT CHIEF

APPROVED January 1, 2022
Scott C. Beck
 ENGINEER OF DESIGN AND ENVIRONMENT

ISSUED 1-1-12

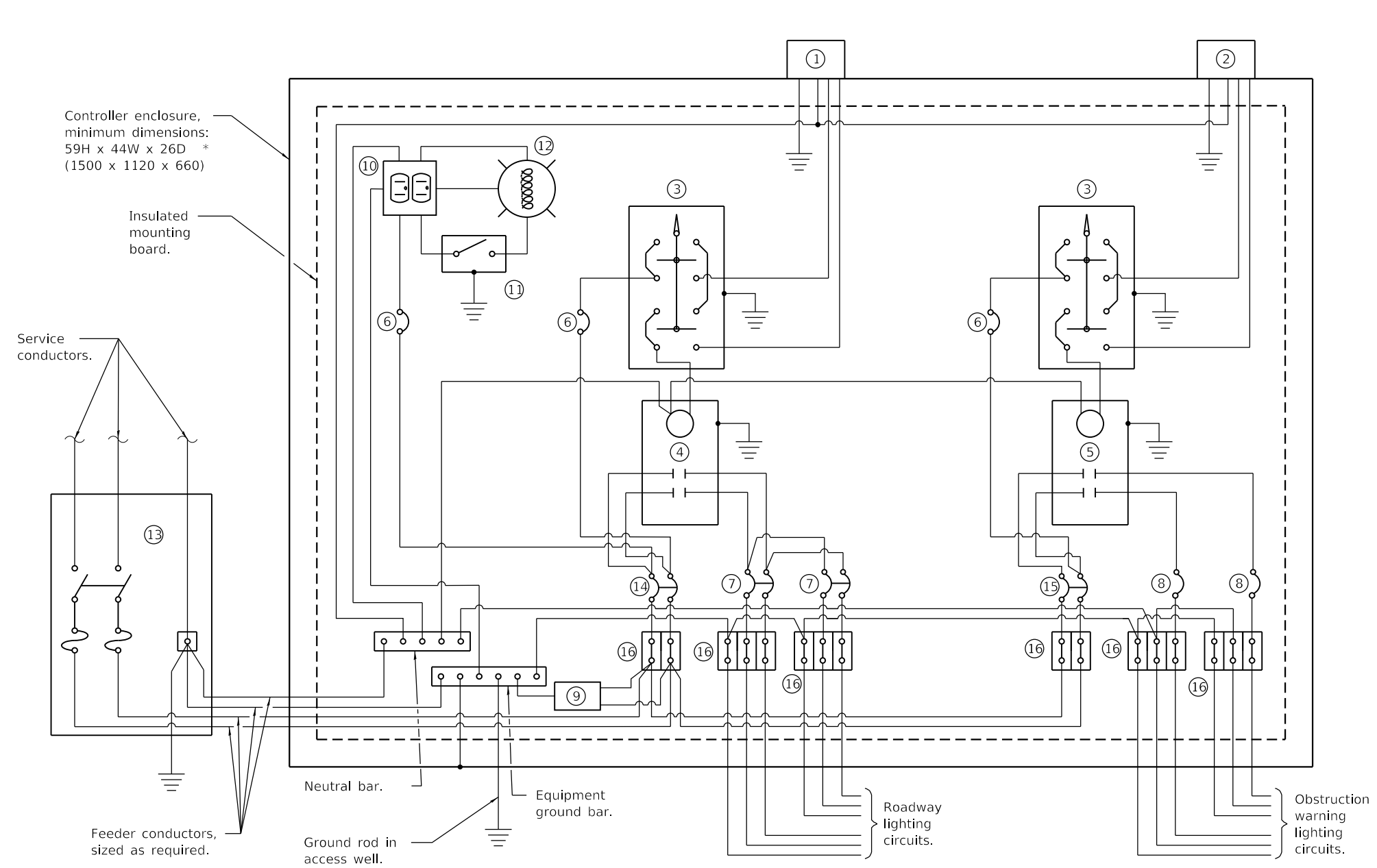

- ① Photocell with integral surge arrester for roadway lighting.
- ② Photocell with integral surge arrester for obstruction warning lighting.
- ③ HAND-OFF-AUTO selector switch.
- ④ 100 amp*, electrically held contactor.
- ⑤ 60 amp*, electrically held contactor.
- ⑥ 15 amp, 1-pole circuit breaker.
- ⑦ 20 amp*, 2-pole circuit breaker (two spares required but not shown).
- ⑧ 20 amp*, single-pole circuit breaker (two shown, quantity as required).
- ⑨ Surge arrester.
- ⑩ GFCI duplex receptacle.
- ⑪ Single-pole, single-throw switch.
- ⑫ Incandescent luminaire, enclosed and gasketed with 100 watt lamp.
- ⑬ Service disconnect switch - 2-pole, 3-wire, 100 amp*, fused at 100 amp*, solid neutral in NEMA 4X enclosure having lockable external handle.
- ⑭ 60 amp*, 2-pole circuit breaker.
- ⑮ 30 amp*, 2-pole circuit breaker.
- ⑯ Terminal block sized for conductors as shown on plans.

* Size larger as needed.

CONTROL SCHEMATIC

Illinois Department of Transportation

PASSED January 1, 2022

Bernard Auffen
ELECTRICAL AND MECHANICAL UNIT CHIEF

APPROVED January 1, 2022

Seth Cbe
ENGINEER OF DESIGN AND ENVIRONMENT

ISSUED 1-1-12

**OBSTRUCTION WARNING
LIGHTING CONTROLLER, 240V**
(Sheet 2 of 2)

STANDARD 826001-03

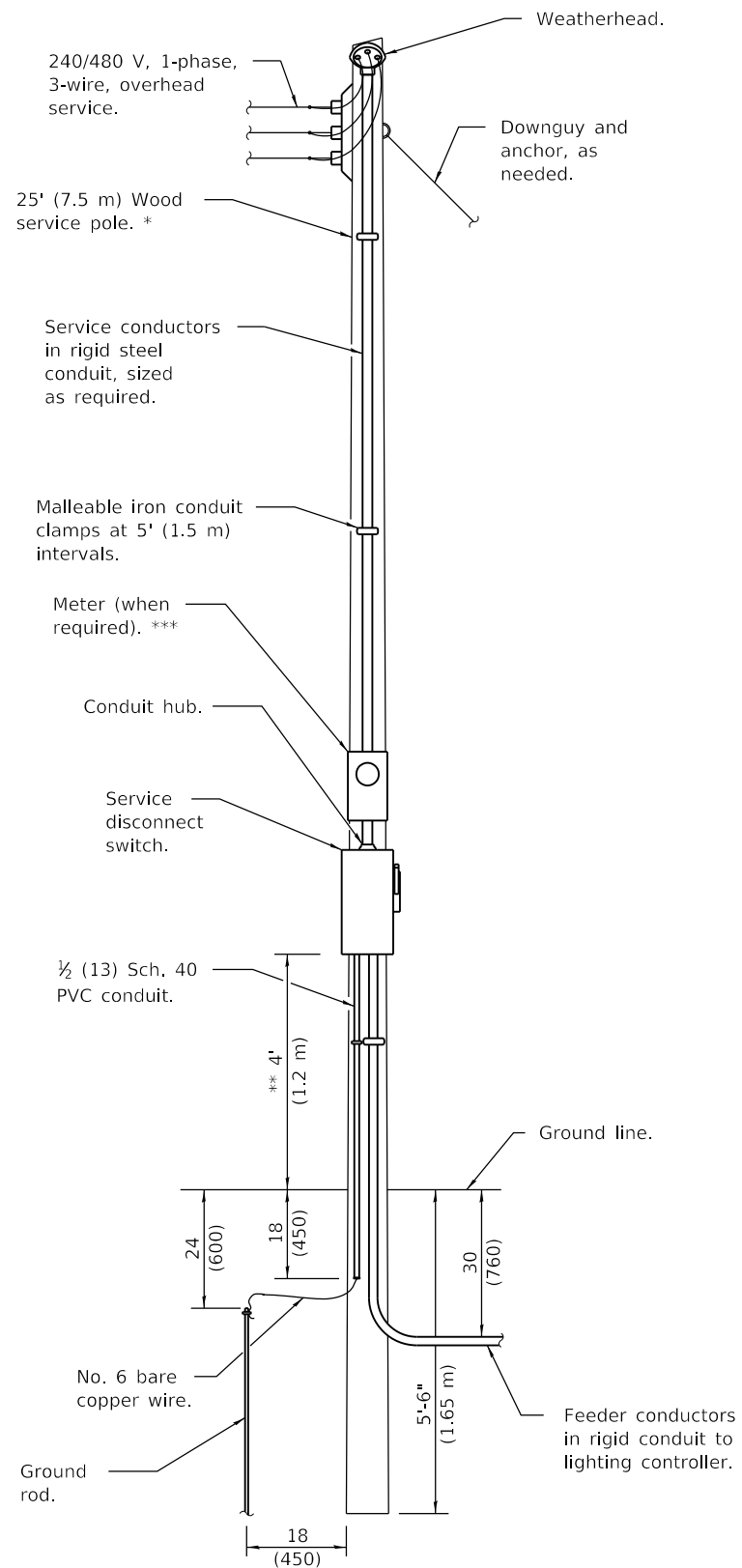

ELECTRIC SERVICE INSTALLATION

(Typical overhead service shown. Cut pole off for underground service and treat cut surface with preservative. Consult utility company standards for exact requirements.)

* Size larger as needed.

** When cold sequencing is required, provide a meter disconnect switch as directed by Utility Company.

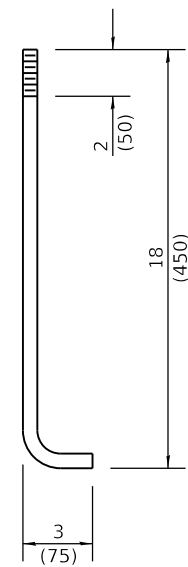

ANCHOR ROD DETAIL

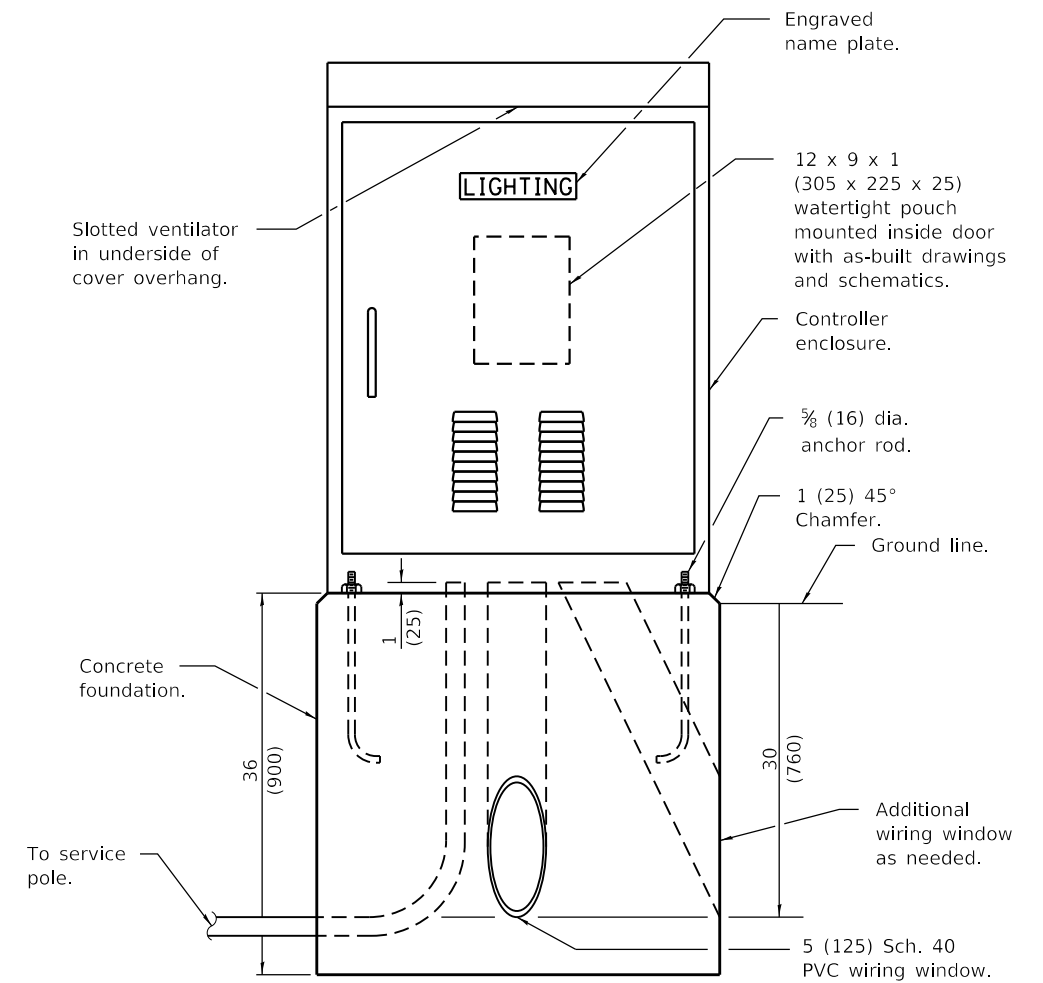

LIGHTING CONTROLLER

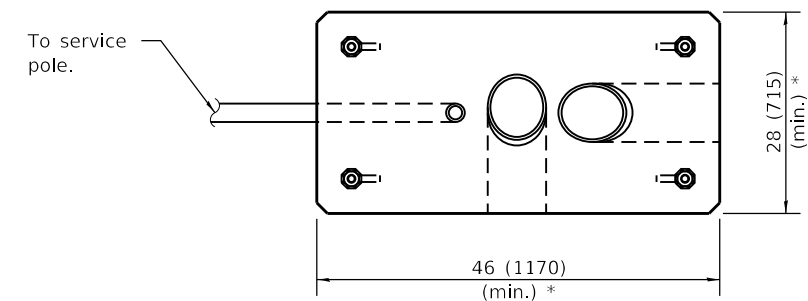

FOUNDATION (PLAN)

(Work pad not shown.)

All dimensions are in inches (millimeters) unless otherwise shown.

DATE	REVISIONS
1-1-22	Replaced "Navigation" with "Obstruction Warning" in std title, note ② and Control Schematic.
1-1-19	Replaced ** note with new note regarding utility company standards. Made *** the ** note.

OBSTRUCTION WARNING LIGHTING CONTROLLER, 480V
(Sheet 1 of 2)

STANDARD 826006-03

Illinois Department of Transportation

PASSED January 1, 2022
Bernard A. Griffin
ELECTRICAL AND MECHANICAL UNIT CHIEF

APPROVED January 1, 2022
John C. ...
ENGINEER OF DESIGN AND ENVIRONMENT

ISSUED 1-1-12

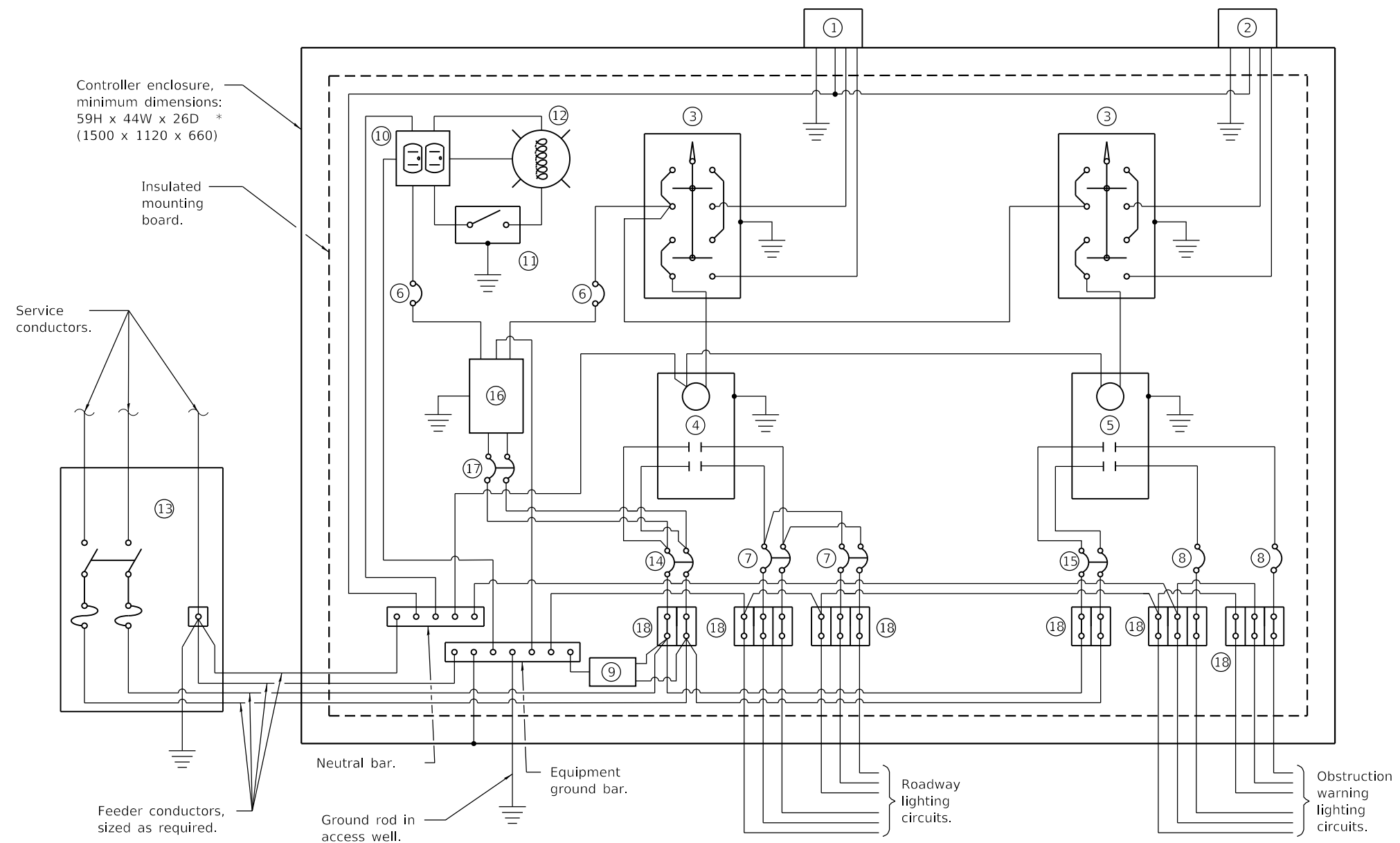

Controller enclosure, minimum dimensions: 59H x 44W x 26D * (1500 x 1120 x 660)

Insulated mounting board.

Service conductors.

Feeder conductors, sized as required.

Neutral bar.

Ground rod in access well.

Equipment ground bar.

Roadway lighting circuits.

Obstruction warning lighting circuits.

- ① Photocell with integral surge arrester for roadway lighting.
- ② Photocell with integral surge arrester for obstruction warning lighting.
- ③ HAND-OFF-AUTO selector switch.
- ④ 100 amp*, electrically held contactor.
- ⑤ 60 amp*, electrically held contactor.
- ⑥ 15 amp, 1-pole circuit breaker.
- ⑦ 20 amp*, 2-pole circuit breaker (two spares required but not shown).
- ⑧ 20 amp*, single-pole circuit breaker (two shown, quantity as required).
- ⑨ Surge arrester.
- ⑩ GFCI duplex receptacle.
- ⑪ Single-pole, single-throw switch.
- ⑫ Incandescent luminaire, enclosed and gasketed with 100 watt lamp.
- ⑬ Service disconnect switch - 2-pole, 3-wire, 100 amp*, fused at 100 amp*, solid neutral in NEMA 4X enclosure having lockable external handle.
- ⑭ 60 amp*, 2-pole circuit breaker.
- ⑮ 30 amp*, 2-pole circuit breaker.
- ⑯ Transformer - 1 KVA*, 480V primary, 120/240V secondary, single phase, 60 Hz.
- ⑰ 15 amp, 2-pole circuit breaker.
- ⑱ Terminal block sized for conductors as shown on plans.

* Size larger as needed.

CONTROL SCHEMATIC

Illinois Department of Transportation

PASSED January 1, 2022

Bernard A. Griffin
ELECTRICAL AND MECHANICAL UNIT CHIEF

APPROVED January 1, 2022

John C. ...
ENGINEER OF DESIGN AND ENVIRONMENT

ISSUED 1-1-12

**OBSTRUCTION WARNING
LIGHTING CONTROLLER, 480V**
(Sheet 2 of 2)

STANDARD 826006-03

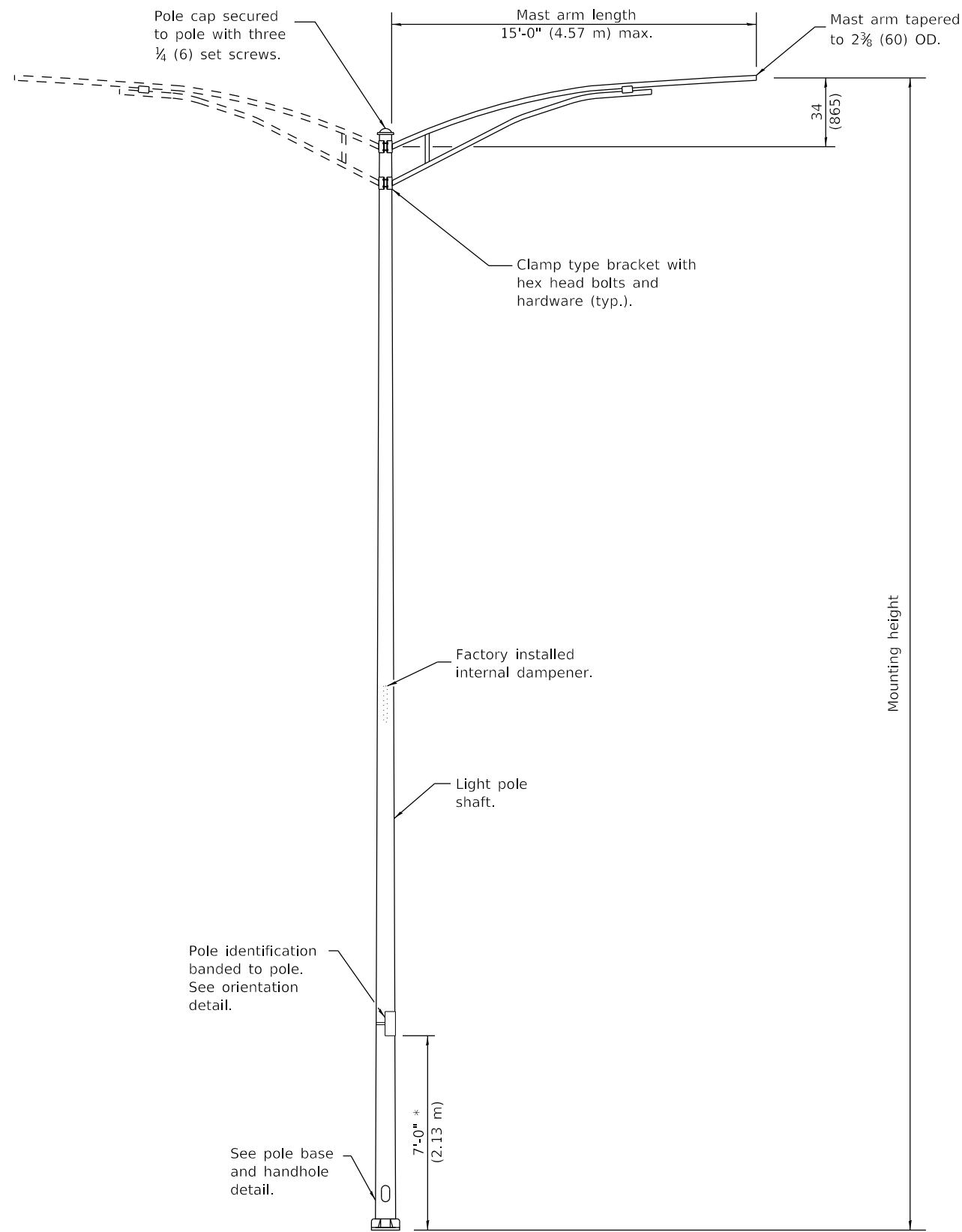

POLE		
MOUNTING HEIGHT	MINIMUM SHAFT DIAMETER	MINIMUM WALL THICKNESS
35' (10.7 m) or less	8 tapered to 4 1/2 (200 to 114)	0.25 (6)
Greater than 35' (10.7 m) to 45' (13.7 m)	10 tapered to 6 (250 to 150)	0.25 (6)
Greater than 45' (13.7 m) to 50' (15.2 m)	10 tapered to 6 (250 to 150)	0.312 (8)

POLE BASE	
MOUNTING HEIGHT	BOLT CIRCLE DIAMETER
35' (10.7 m) or less	11 1/2 (290)
Greater than 35' (10.7 m) to 50' (15.2 m)	15 (380)

GENERAL NOTES

See Standard 836001 for Light Pole Foundation and grounding electrode.

See Standard 720001 for pole identification banding to pole.

Voids in light pole base shall be sealed to prevent rodent entry.

Provide breakaway devices where required.

Where anchor rods on existing bridge parapets are too short to mount poles as shown, install leveling plate directly on concrete and level with stainless steel washers.

All dimensions are in inches (millimeters) unless otherwise shown.

MAST ARM LIGHT POLE

(Single or twin mount)

* Unless directed otherwise by the Engineer.

DATE	REVISIONS
1-1-15	Revised note on HANDHOLE DETAIL.
1-1-14	Added pole mounted on bridge parapet. Modified attachment of screen.

**LIGHT POLE
ALUMINUM MAST ARM**

(Sheet 1 of 2)

STANDARD 830001-03

Illinois Department of Transportation

APPROVED January 1, 2015

 ENGINEER OF PRELIMINARY ENGINEERING

APPROVED January 1, 2015

 ENGINEER OF DESIGN AND ENVIRONMENT

ISSUED 1-1-12

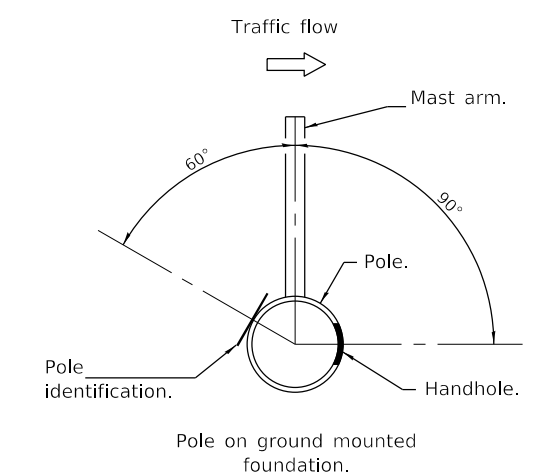
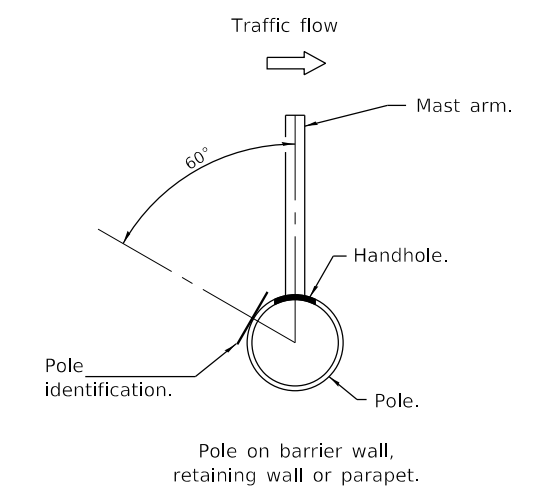
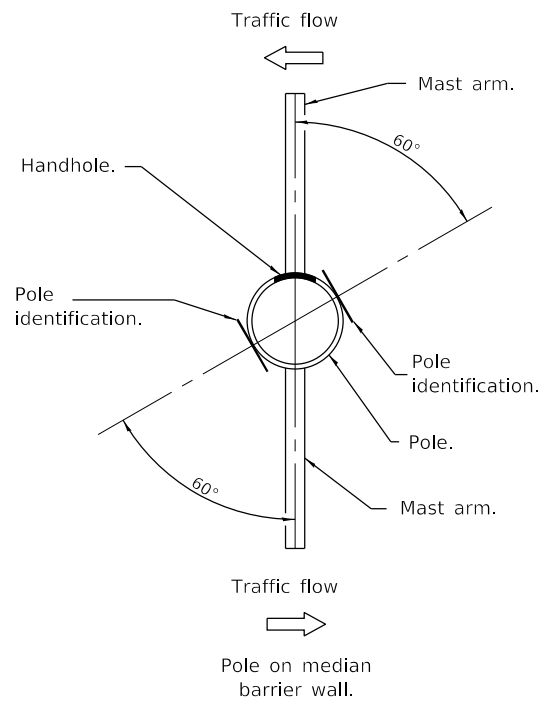

HANDHOLE / IDENTIFICATION ORIENTATION DETAIL

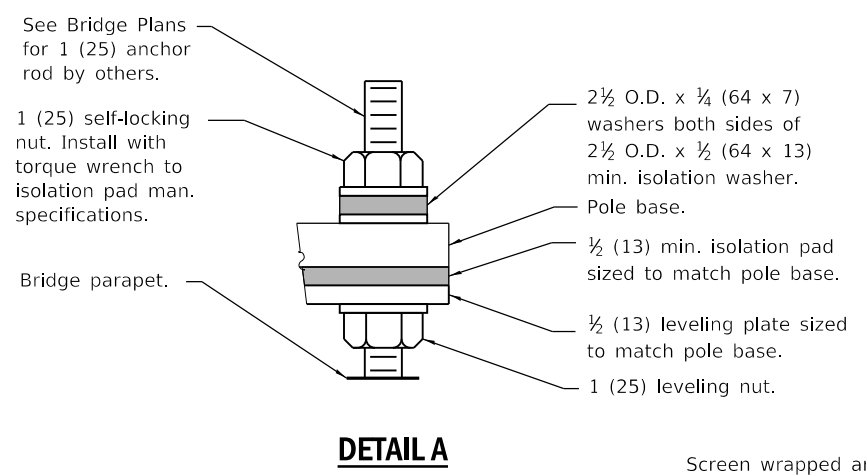
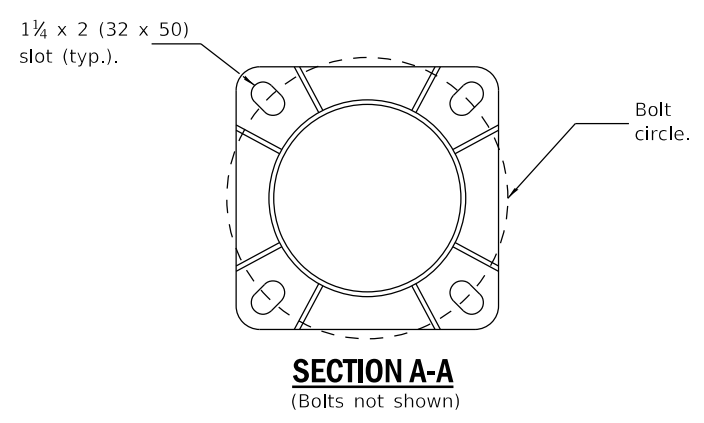

DETAIL A

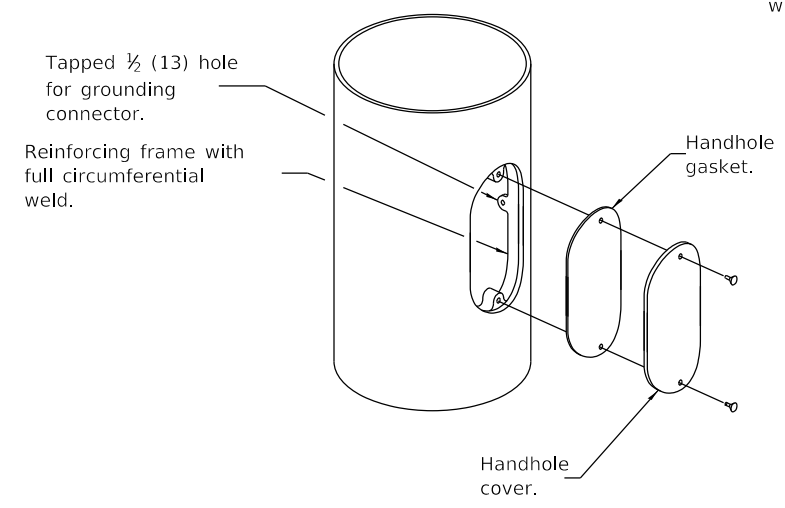

HANDHOLE DETAIL

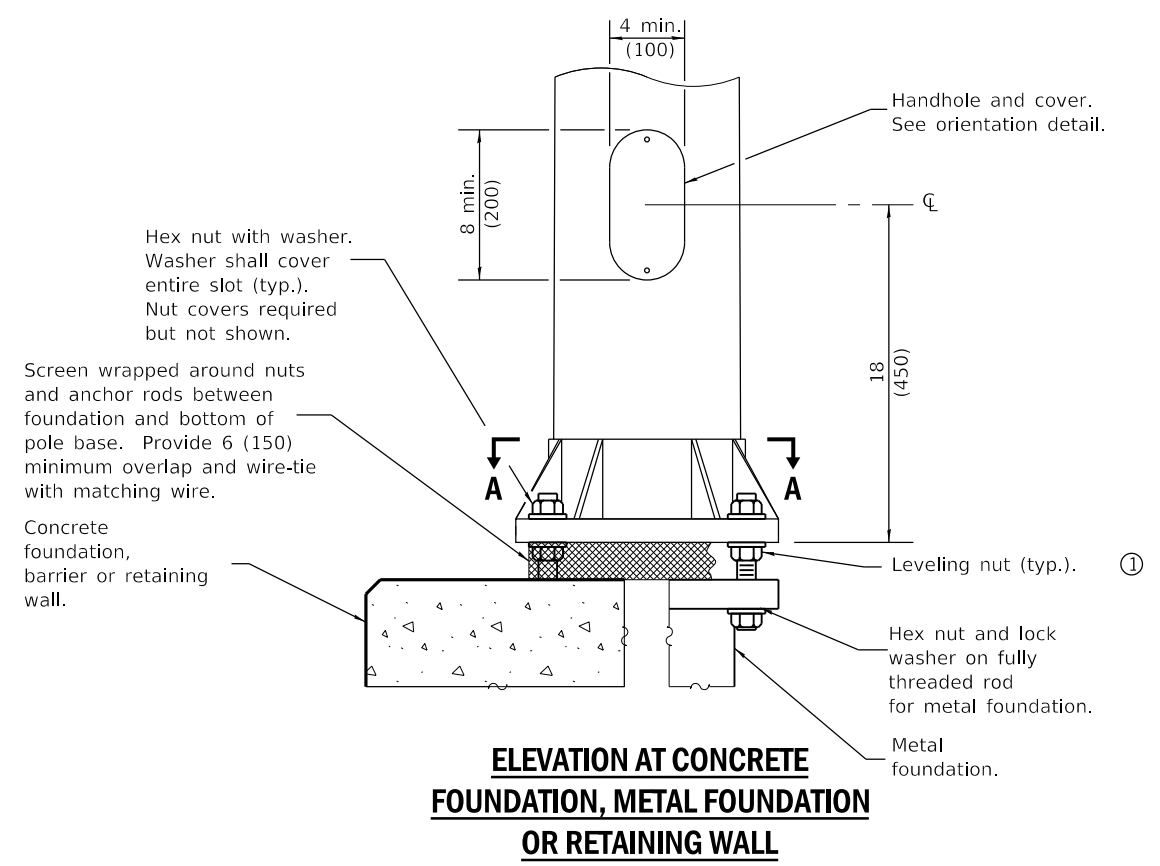

① Omit leveling nuts when breakaway devices are required.

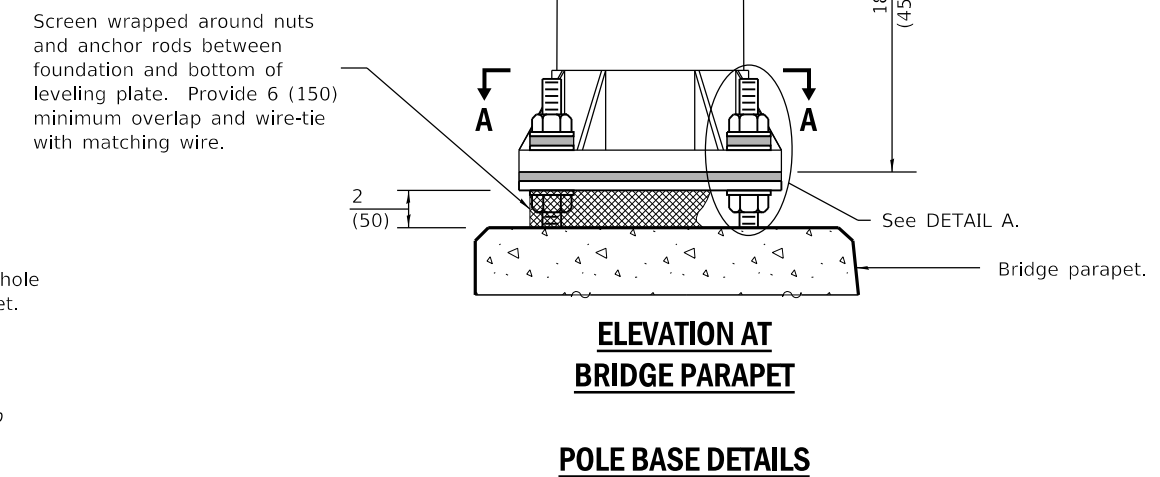

POLE BASE DETAILS

LIGHT POLE ALUMINUM MAST ARM

(Sheet 2 of 2)

STANDARD 830001-03

Illinois Department of Transportation

APPROVED January 1, 2015
Cheryl Gentry
 ENGINEER OF PRELIMINARY ENGINEERING

APPROVED January 1, 2015
[Signature]
 ENGINEER OF DESIGN AND ENVIRONMENT

ISSUED 1-1-12

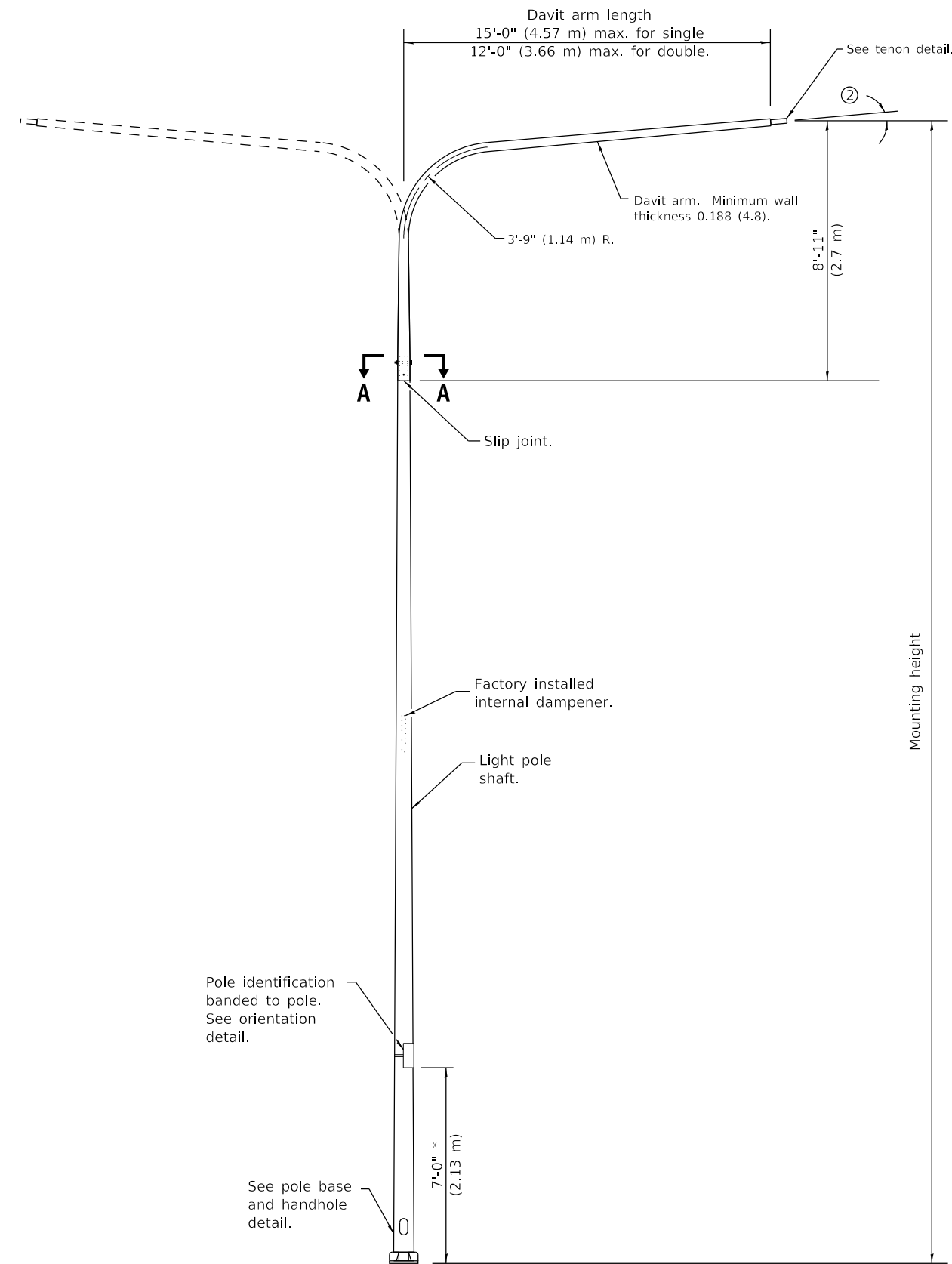

POLE BASE	
MOUNTING HEIGHT	BOLT CIRCLE DIAMETER
35' (10.7 m) or less	11½ (290)
Greater than 35' (10.7 m) to 50' (15.2 m)	15 (380)

POLE LOWER SHAFT			
MOUNTING HEIGHT	LOWER SHAFT LENGTH ①	MINIMUM SHAFT DIAMETER	MINIMUM WALL THICKNESS
30' (9.1 m)	21'-1" (6.4 m)	8 tapered to 6 (200 to 114)	0.25 (6)
35' (10.7 m)	26'-1" (7.9 m)	8 tapered to 6 (200 to 114)	0.25 (6)
40' (12.2 m)	31'-1" (9.5 m)	10 tapered to 6 (250 to 150)	0.25 (6)
45' (13.7 m)	36'-1" (11.0 m)	10 tapered to 6 (250 to 150)	0.25 (6)
50' (15.2 m)	41'-1" (12.5 m)	10 tapered to 6 (250 to 150)	0.312 (8)

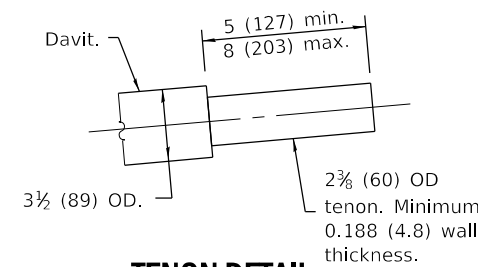

TENON DETAIL

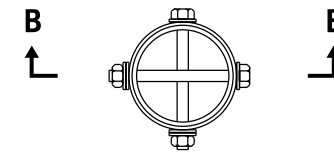

SECTION A-A

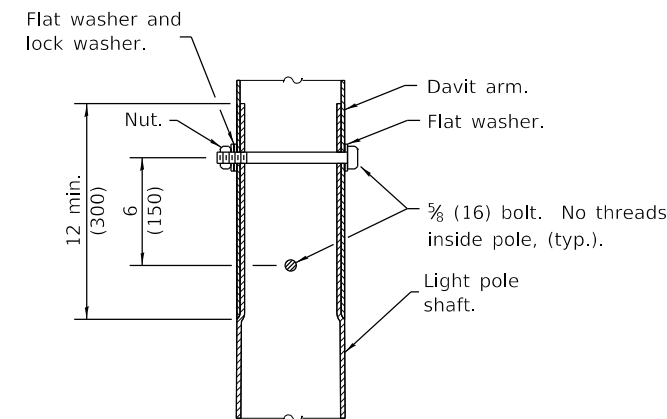

SECTION B-B

- ① Lower shaft length shall be from the bottom of the pole base to the bottom of the slip joint.
- ② 5° max. for unloaded pole, 1.5° max. for loaded pole.

GENERAL NOTES

See Standard 836001 for Light Pole Foundation and grounding electrode.

See Standard 720001 for pole identification banding to pole.

Voids in light pole base shall be sealed to prevent rodent entry.

Provide breakaway devices where required.

Where anchor rods on existing bridge parapets are too short to mount poles as shown, install leveling plate directly on concrete and level with stainless steel washers.

All dimensions are in inches (millimeters) unless otherwise shown.

DATE	REVISIONS
1-1-19	Revised standard to comply with the 2013 version of AASHTO.
1-1-17	Added notes ③ and ④.

**LIGHT POLE
ALUMINUM DAVIT ARM**

(Sheet 1 of 2)

STANDARD 830006-05

Illinois Department of Transportation

PASSED January 1, 2019
ME Reppelt
 ELECTRICAL AND MECHANICAL UNIT CHIEF

APPROVED January 1, 2019
J. E. ...
 ENGINEER OF DESIGN AND ENVIRONMENT

ISSUED 1-1-12

DAVIT LIGHT POLE

(Single or twin mount)

* Unless directed otherwise by the Engineer.

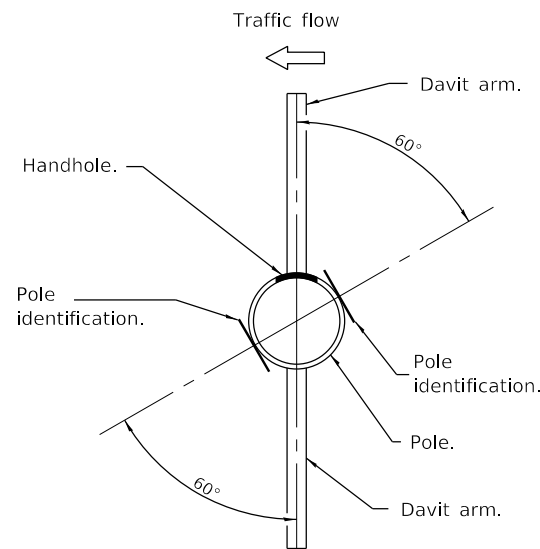

Traffic flow
 Pole on median barrier wall.

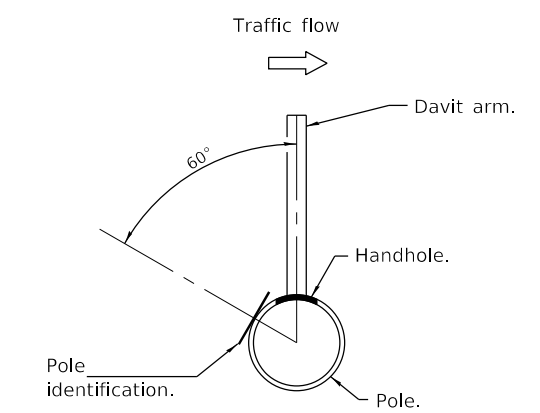

Pole on barrier wall, retaining wall or parapet.

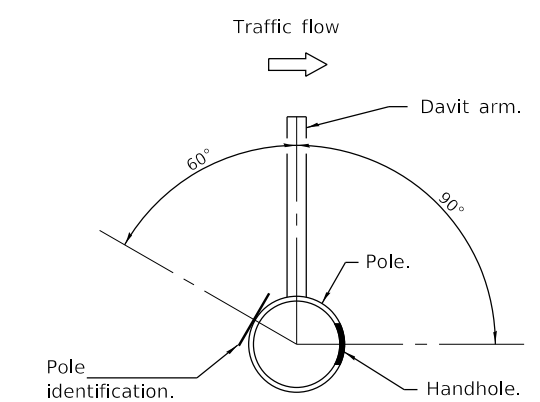

Pole on ground mounted foundation.

HANDHOLE / IDENTIFICATION ORIENTATION DETAIL

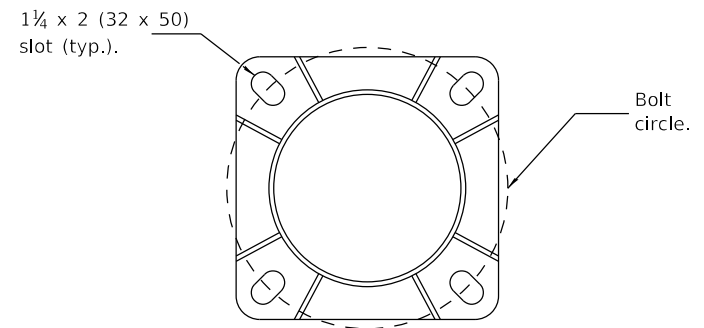

SECTION A-A
 (Bolts not shown)

See Bridge Plans for 1 (25) anchor rod by others.
 1 (25) self-locking nut. Install with torque wrench to isolation pad man. specifications.

Bridge parapet.

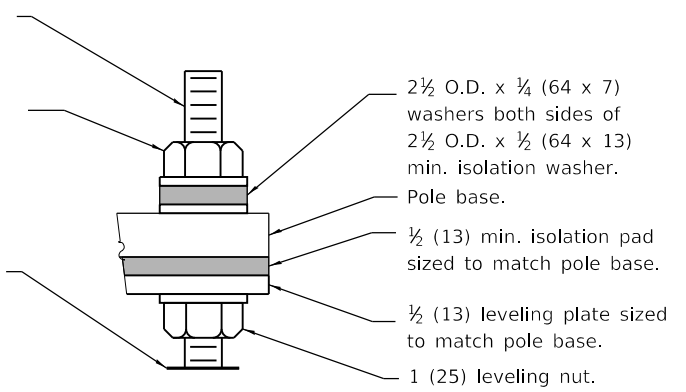

DETAIL A

Tapped 1/2 (13) hole for grounding connector.

Reinforcing frame with full circumferential weld.

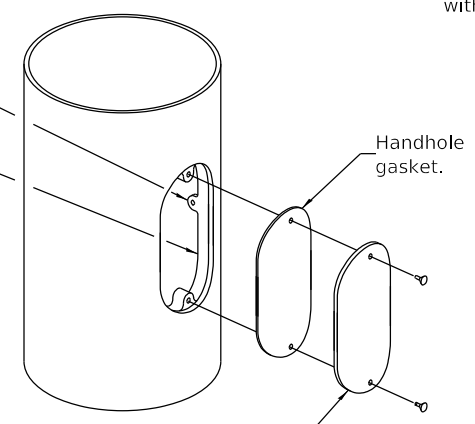

HANDHOLE DETAIL

Hex nut with washer. Washer shall cover entire slot (typ.). Nut covers required but not shown.

Screen wrapped around nuts and anchor rods between foundation and bottom of pole base. Provide 6 (150) minimum overlap and wire-tie with matching wire.

Concrete foundation, barrier or retaining wall.

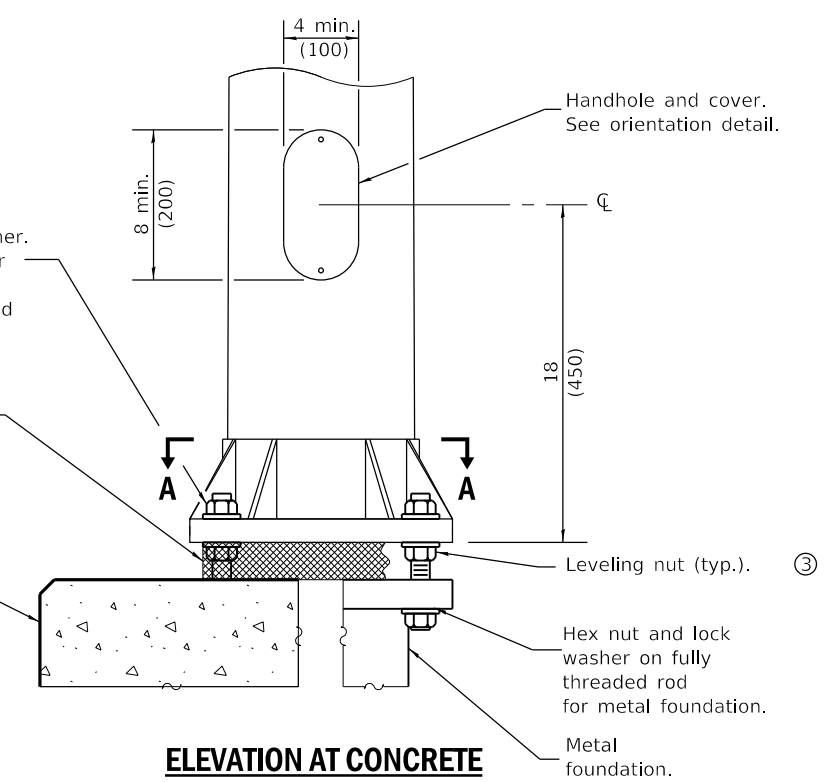

ELEVATION AT CONCRETE FOUNDATION, METAL FOUNDATION OR RETAINING WALL

③ Omit leveling nuts when breakaway devices are required.

Screen wrapped around nuts and anchor rods between foundation and bottom of leveling plate. Provide 6 (150) minimum overlap and wire-tie with matching wire.

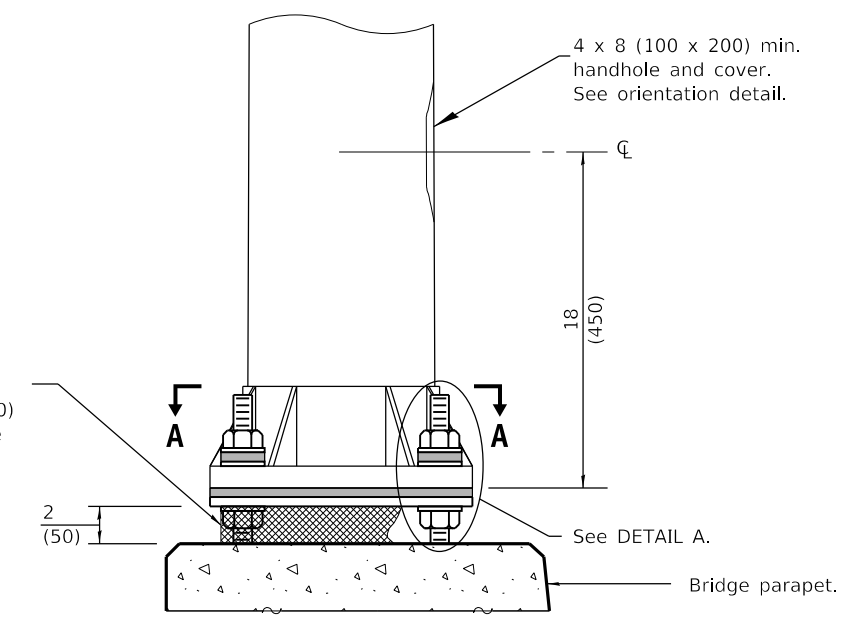

ELEVATION AT BRIDGE PARAPET

POLE BASE DETAILS

Illinois Department of Transportation
 PASSED January 1, 2019
 ME Reppelt
 ELECTRICAL AND MECHANICAL UNIT CHIEF
 APPROVED January 1, 2019
 J. E. ...
 ENGINEER OF DESIGN AND ENVIRONMENT
 ISSUED 1-1-12

LIGHT POLE ALUMINUM DAVIT ARM
 (Sheet 2 of 2)
STANDARD 830006-05

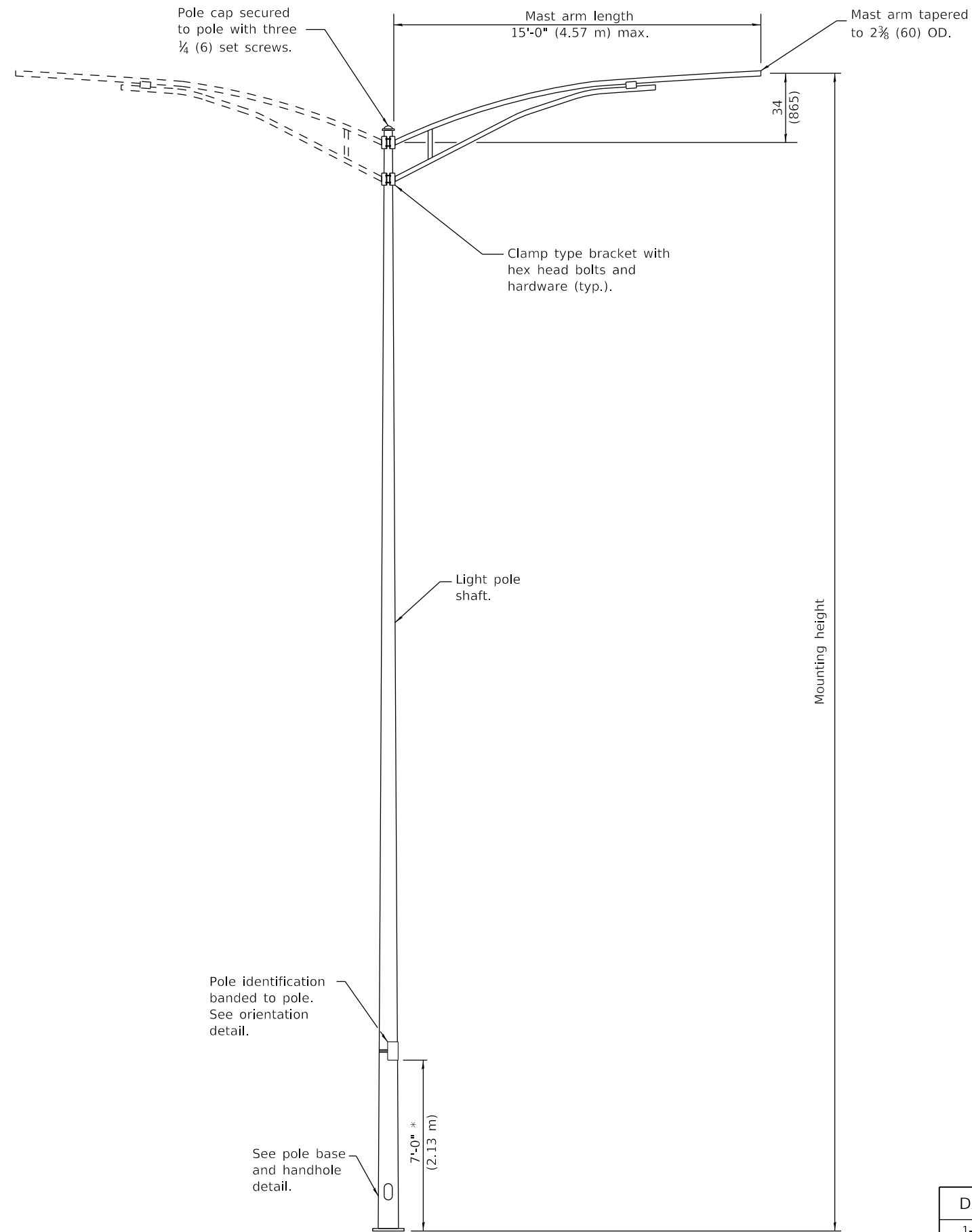

POLE		
MOUNTING HEIGHT	MINIMUM SHAFT DIAMETER	MINIMUM WALL THICKNESS
35' (10.7 m) or less	8 tapered to 4 (200 to 100)	10 gauge
Greater than 35' (10.7 m) to 50' (15.2 m)	10 tapered to 4 (250 to 100)	7 gauge

BASE PLATE		
MOUNTING HEIGHT	BOLT CIRCLE DIAMETER	BASE PLATE THICKNESS
35' (10.7 m) or less	11 1/2 (290)	1 (25)
Greater than 35' (10.7 m) to 50' (15.2 m)	15 (380)	1 1/4 (32)

GENERAL NOTES

See Standard 836001 for Light Pole Foundation and grounding electrode.

See Standard 720001 for pole identification banding to pole.

Provide breakaway devices where required.

Where anchor rods on existing bridge parapets are too short to mount poles as shown, install leveling plate directly on concrete and level with stainless steel washers.

All dimensions are in inches (millimeters) unless otherwise shown.

DATE	REVISIONS
1-1-19	Revised POLE and BASE POLE tables.
1-1-14	Added pole mounted on bridge parapet. Modified attachment of screen.

**LIGHT POLE
STEEL MAST ARM**

(Sheet 1 of 2)

STANDARD 830011-03

**MAST ARM
LIGHT POLE**

(Single or twin mount)

* Unless directed otherwise by the Engineer.

Illinois Department of Transportation

PASSED January 1, 2019
ME Reppelt
 ELECTRICAL AND MECHANICAL UNIT CHIEF

APPROVED January 1, 2019
J. E. ...
 ENGINEER OF DESIGN AND ENVIRONMENT

ISSUED 1-1-12

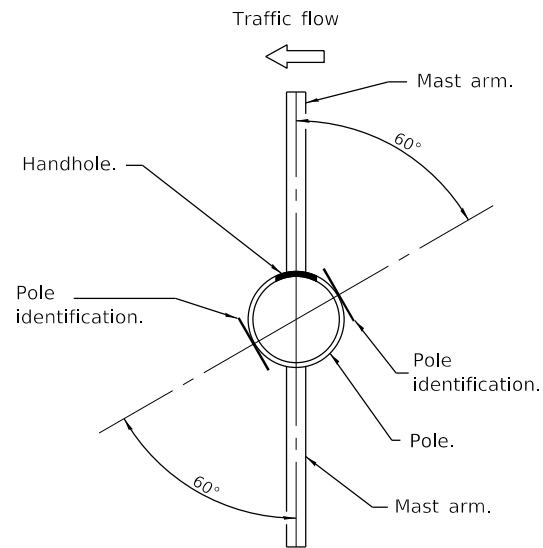

Traffic flow
Pole on median barrier wall.

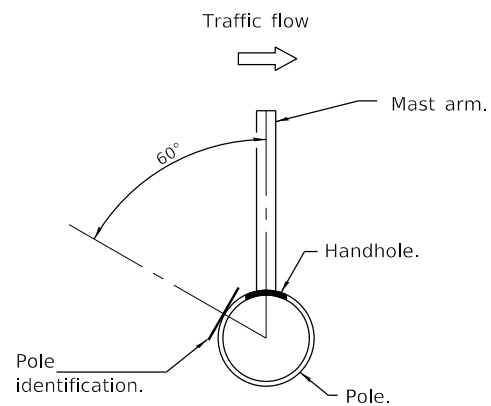

Traffic flow
Pole on barrier wall, retaining wall or parapet.

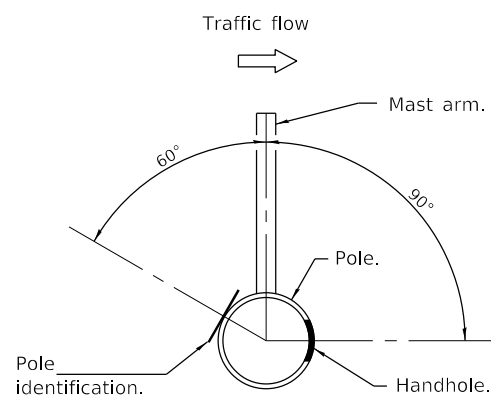

Traffic flow
Pole on ground mounted foundation.

HANDHOLE / IDENTIFICATION ORIENTATION DETAIL

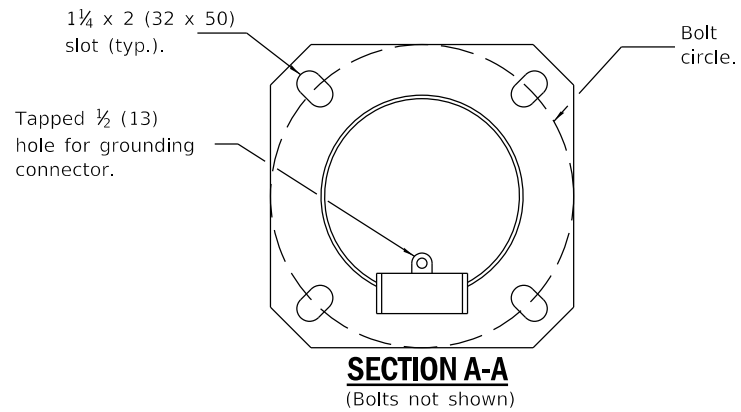

See Bridge Plans for 1 (25) anchor rod by others.

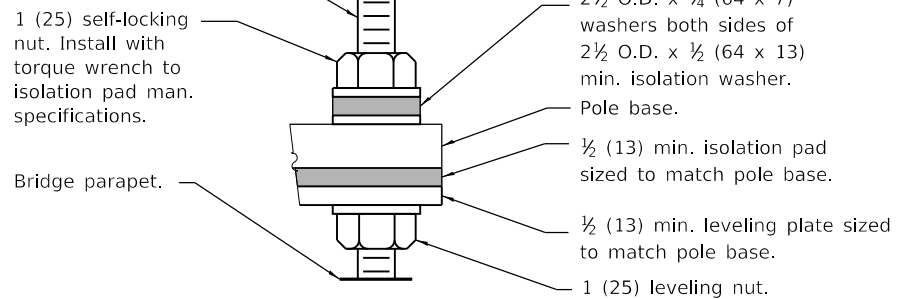

DETAIL A

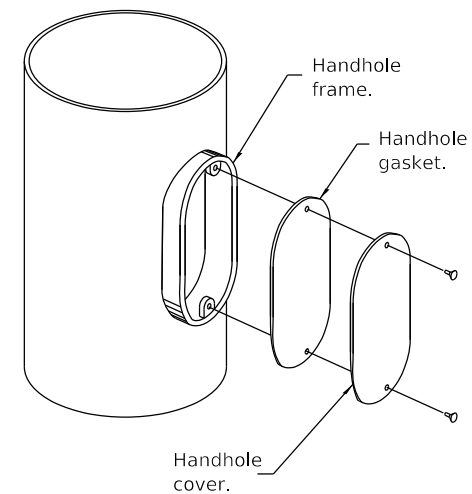

HANDHOLE DETAIL

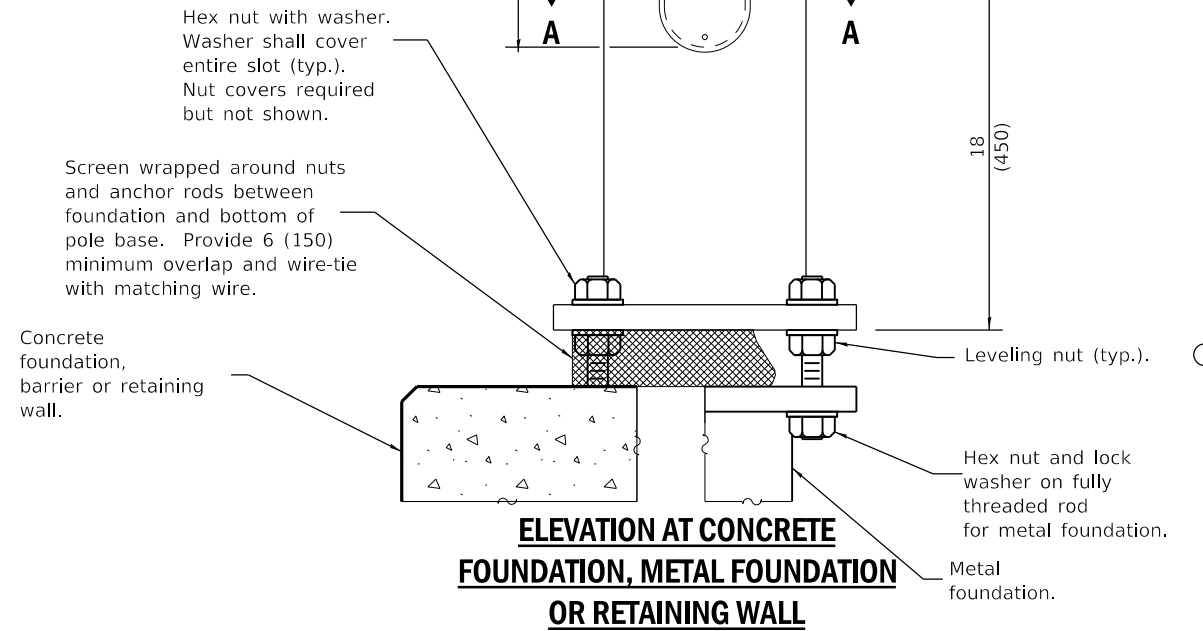

① Omit leveling nuts when breakaway devices are required.

Screen wrapped around nuts and anchor rods between foundation and bottom of leveling plate. Provide 6 (150) minimum overlap and wire-tie with matching wire.

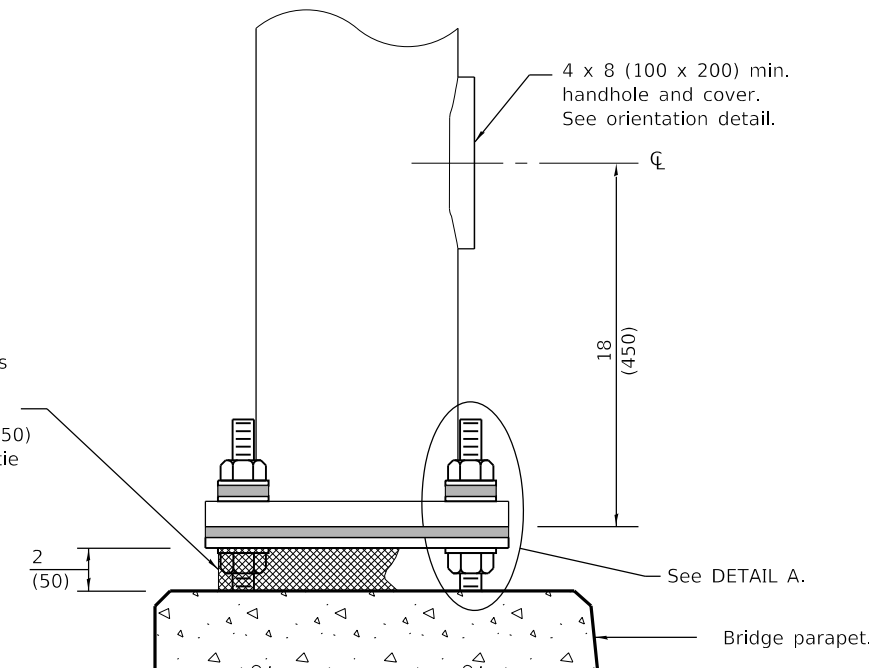

POLE BASE DETAILS

LIGHT POLE STEEL MAST ARM

(Sheet 2 of 2)

STANDARD 830011-03

Illinois Department of Transportation

PASSED January 1, 2019
ME Reppelt
ELECTRICAL AND MECHANICAL UNIT CHIEF

APPROVED January 1, 2019
J. E. C.
ENGINEER OF DESIGN AND ENVIRONMENT

ISSUED 1-1-12

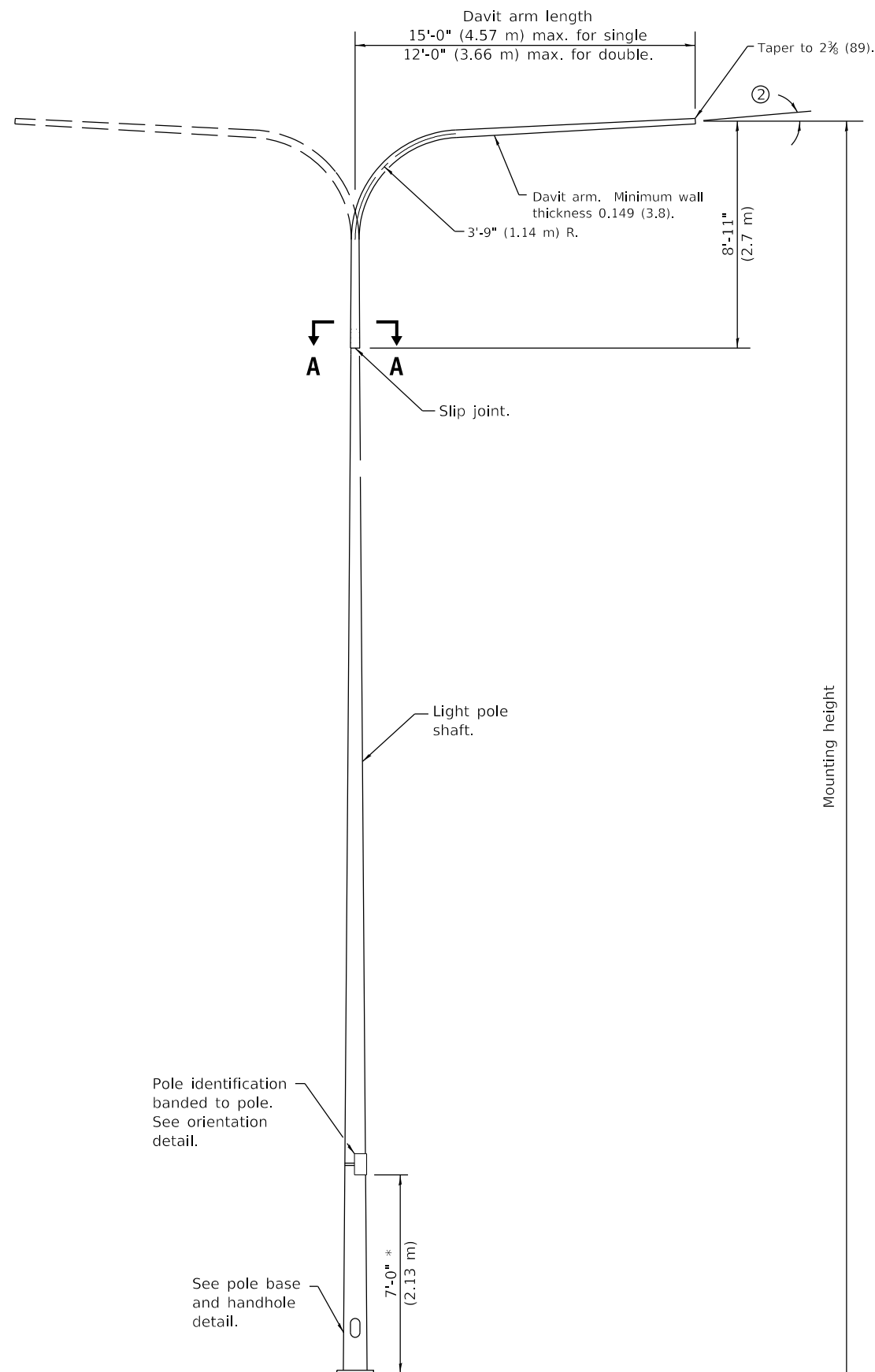

BASE PLATE		
MOUNTING HEIGHT	BOLT CIRCLE DIAMETER	BASE PLATE THICKNESS
35' (10.7 m) or less	11½ (290)	1 (25)
Greater than 35' (10.7 m) to 50' (15.2 m)	15 (380)	1¼ (32)

POLE LOWER SHAFT			
MOUNTING HEIGHT	LOWER SHAFT LENGTH ①	MINIMUM SHAFT DIAMETER	MINIMUM WALL THICKNESS
30' (9.1 m)	21'-1" (6.4 m)	8 tapered to 6 (200 to 114)	10 gauge
35' (10.7 m)	26'-1" (7.9 m)	8 tapered to 6 (200 to 114)	10 gauge
40' (12.2 m)	31'-1" (9.5 m)	10 tapered to 6 (250 to 150)	7 gauge
45' (13.7 m)	36'-1" (11.0 m)	10 tapered to 6 (250 to 150)	7 gauge
50' (15.2 m)	41'-1" (12.5 m)	10 tapered to 6 (250 to 150)	7 gauge

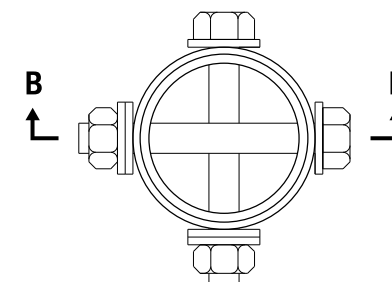

SECTION A-A

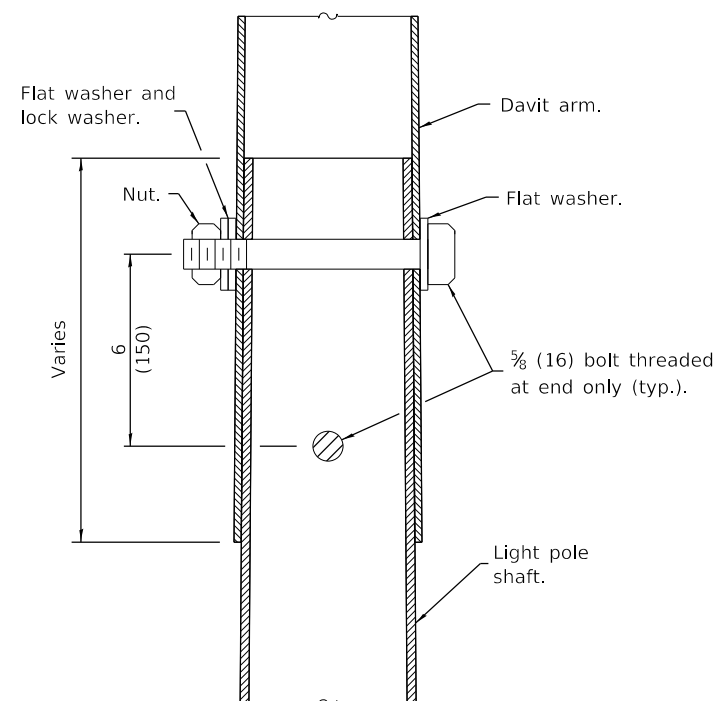

SECTION B-B

- ① Lower shaft length shall be from the bottom of the pole base to the bottom of the slip joint.
- ② 3° max. for unloaded pole, 1.5° max. for loaded pole.

GENERAL NOTES

See Standard 836001 for Light Pole Foundation and grounding electrode.

See Standard 720001 for pole identification banding to pole.

Provide breakaway devices where required.

Where anchor rods on existing bridge parapets are too short to mount poles as shown, install leveling plate directly on concrete and level with stainless steel washers.

All dimensions are in inches (millimeters) unless otherwise shown.

**LIGHT POLE
STEEL DAVIT ARM**

(Sheet 1 of 2)

STANDARD 830016-03

DATE	REVISIONS
1-1-19	Revised BASE PLATE table.
1-1-14	Added pole mounted on bridge parapet. Modified attachment of screen.

Illinois Department of Transportation

PASSED January 1, 2019
ME Reppelt
 ELECTRICAL AND MECHANICAL UNIT CHIEF

APPROVED January 1, 2019
J. E. ...
 ENGINEER OF DESIGN AND ENVIRONMENT

ISSUED 1-1-12

DAVIT LIGHT POLE

(Single or twin mount)

* Unless directed otherwise by the Engineer.

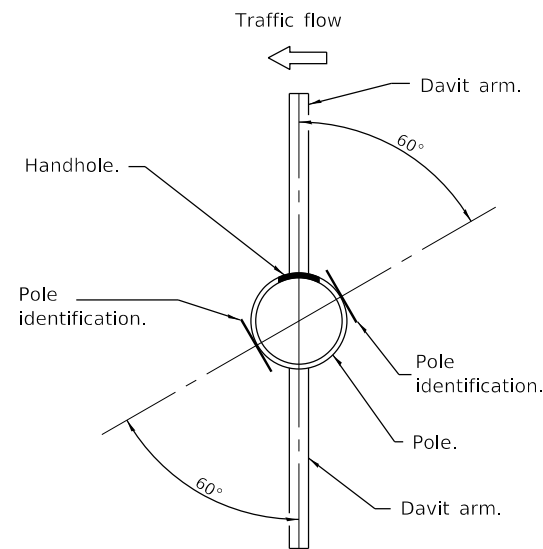

Traffic flow

Pole on median barrier wall.

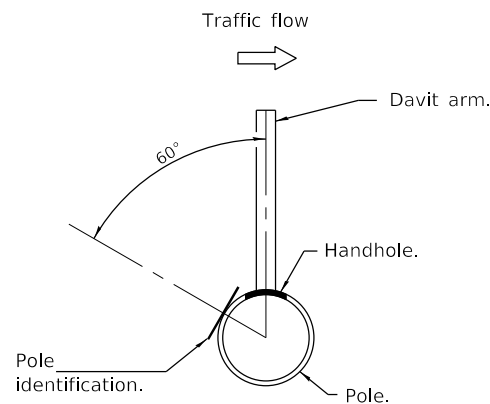

Pole on barrier wall, retaining wall or parapet.

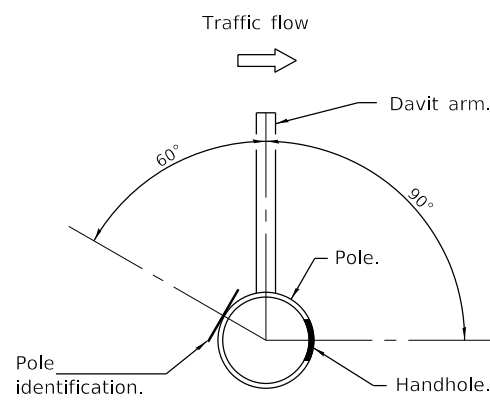

Pole on ground mounted foundation.

HANDHOLE / IDENTIFICATION ORIENTATION DETAIL

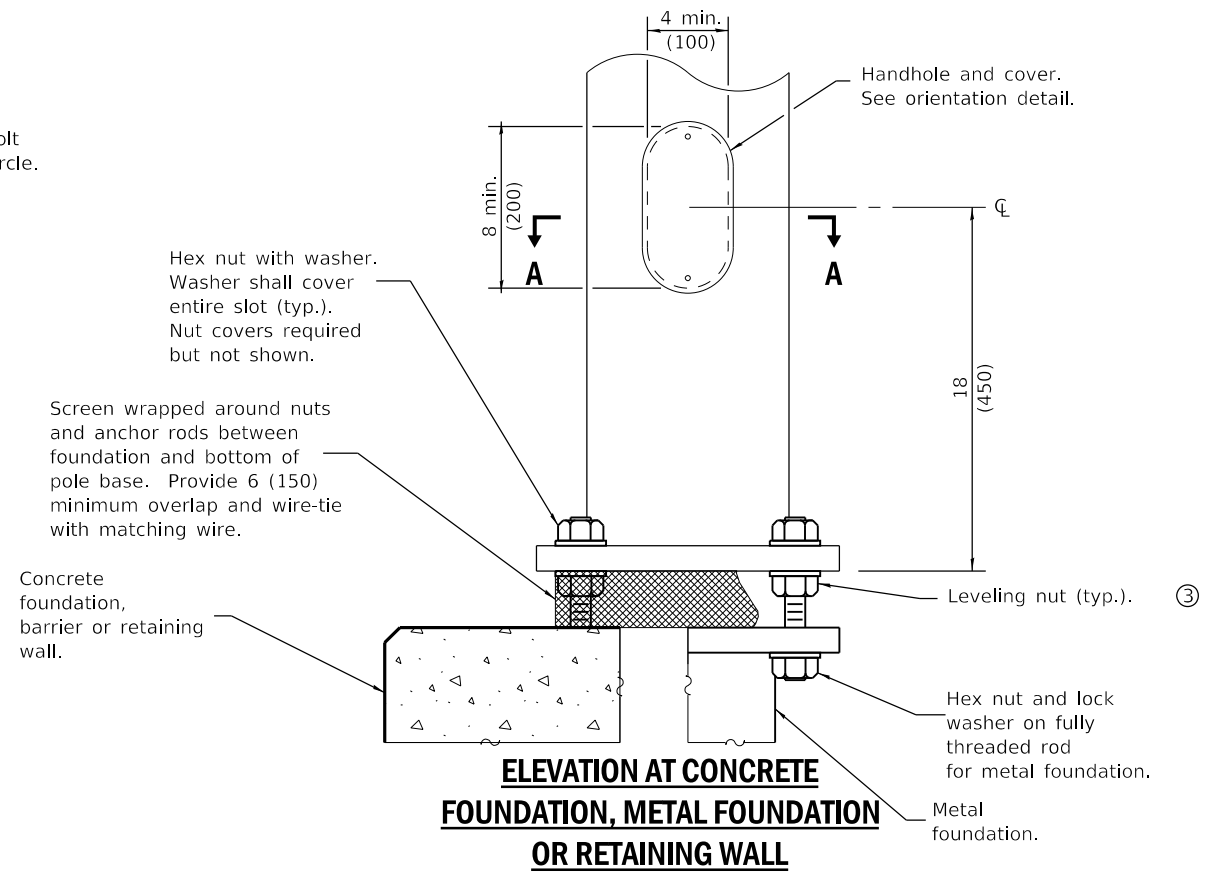
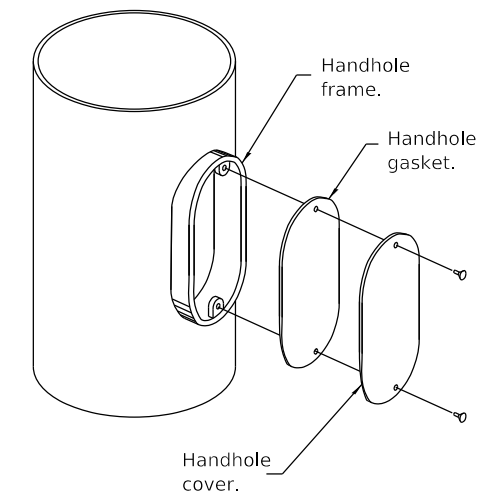
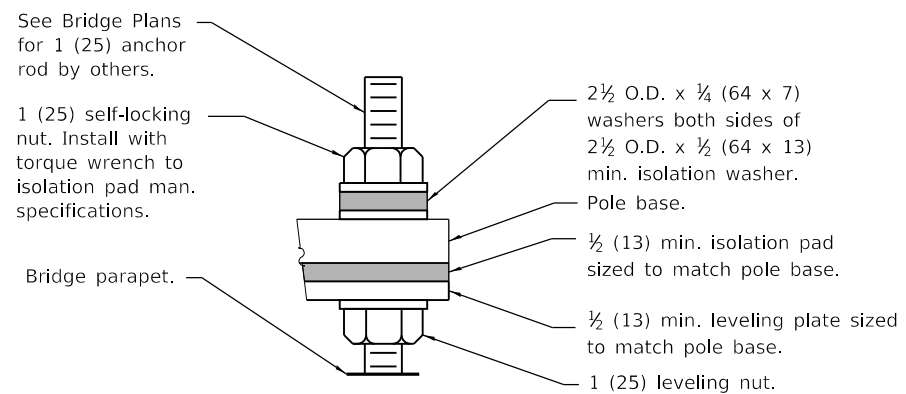
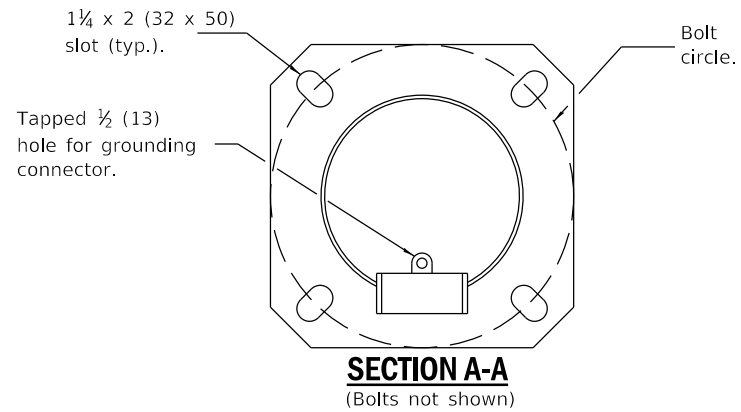

③ Omit leveling nuts when breakaway devices are required.

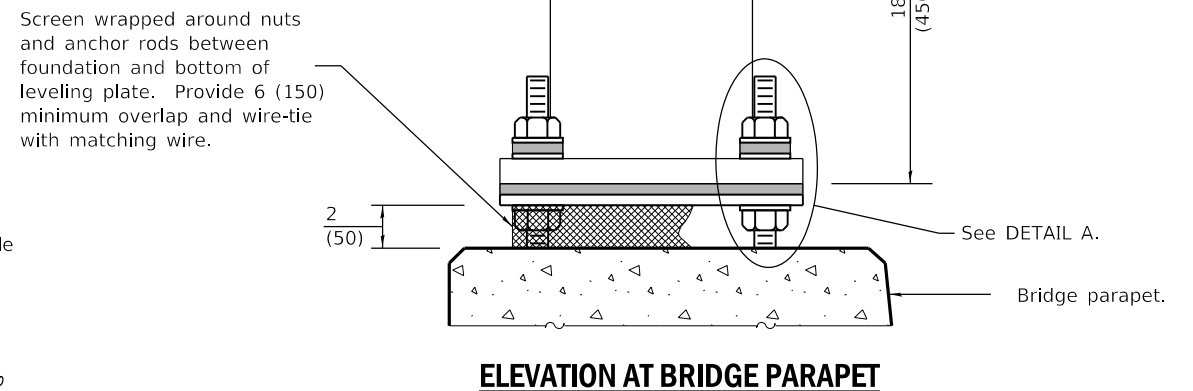

POLE BASE DETAILS

LIGHT POLE STEEL DAVIT ARM

(Sheet 2 of 2)

STANDARD 830016-03

Illinois Department of Transportation

PASSED January 1, 2019

ME Reppelt
ELECTRICAL AND MECHANICAL UNIT CHIEF

APPROVED January 1, 2019

J. E. ...
ENGINEER OF DESIGN AND ENVIRONMENT

ISSUED 1-1-12

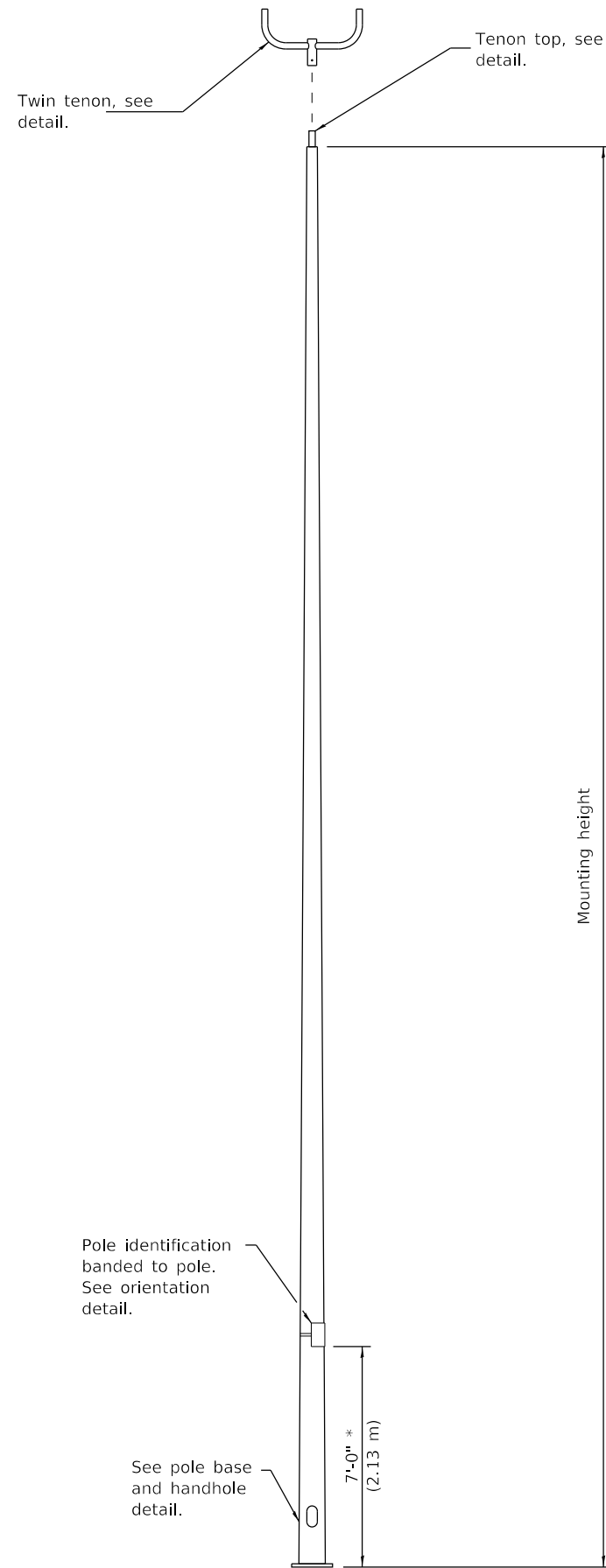

TENON TOP LIGHT POLE

(Single or twin mount)

* Unless directed otherwise by the Engineer.

BASE PLATE		
MOUNTING HEIGHT	BOLT CIRCLE DIAMETER	BASE PLATE THICKNESS
35' (10.7 m) or less	11½ (290)	1 (25)
Greater than 35' (10.7 m) to 50' (15.2 m)	15 (380)	1¼ (32)

LIGHT POLE		
MOUNTING HEIGHT	MINIMUM SHAFT DIAMETER	MINIMUM WALL THICKNESS
35' (10.7 m) or less	8 tapered to 4 (200 to 100)	10 guage
Greater than 35' (10.7 m) to 50' (15.2 m)	10 tapered to 4 (250 to 100)	7 guage

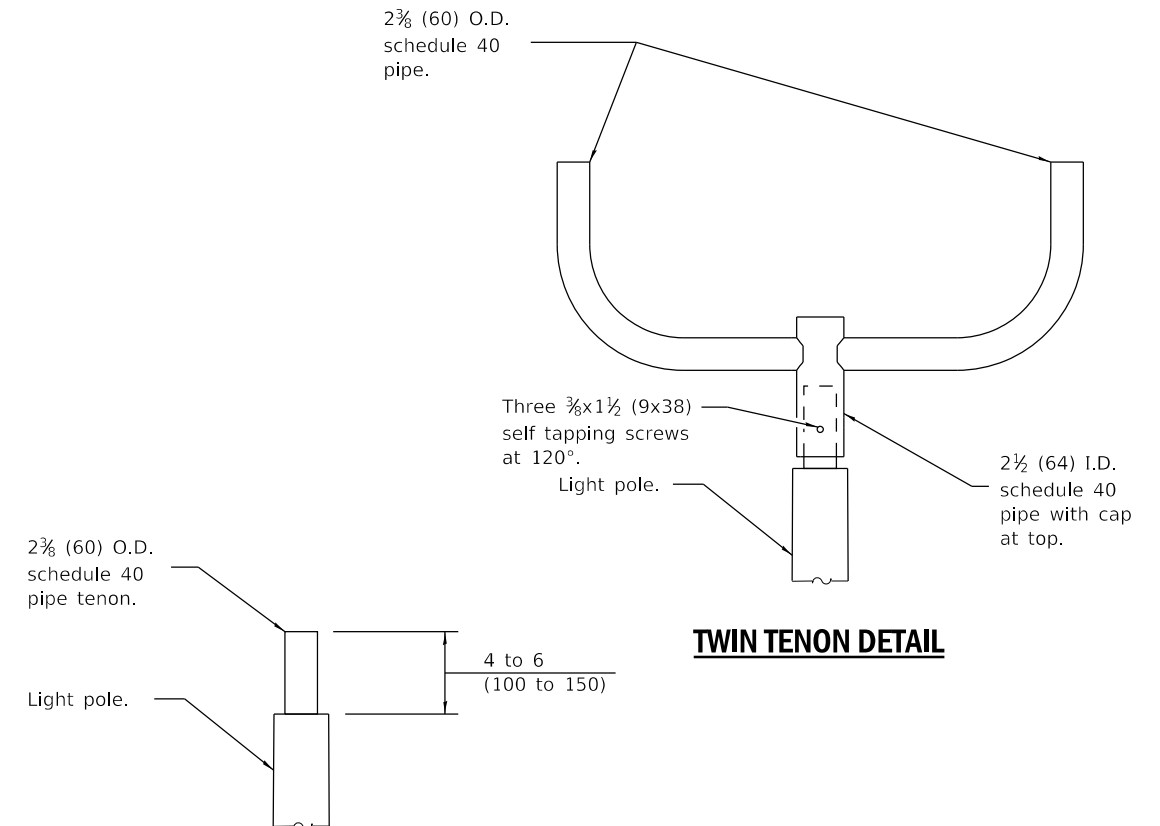

TENON DETAIL

TWIN TENON DETAIL

GENERAL NOTES

See Standard 836001 for Light Pole Foundation and grounding electrode.

See Standard 720001 for pole identification banding to pole.

Provide breakaway devices where required.

Where anchor rods on existing bridge parapets are too short to mount poles as shown, install leveling plate directly on concrete and level with stainless steel washers.

All dimensions are in inches (millimeters) unless otherwise shown.

DATE	REVISIONS
1-1-19	Revised BASE PLATE and LIGHT POLE tables.
1-1-14	Added pole mounted on bridge parapet. Modified attachment of screen.

LIGHT POLE STEEL TENON TOP

(Sheet 1 of 2)

STANDARD 830021-03

Illinois Department of Transportation

PASSED January 1, 2019

ME Reppelt
ELECTRICAL AND MECHANICAL UNIT CHIEF

APPROVED January 1, 2019

J. E. ...
ENGINEER OF DESIGN AND ENVIRONMENT

ISSUED 1-1-12

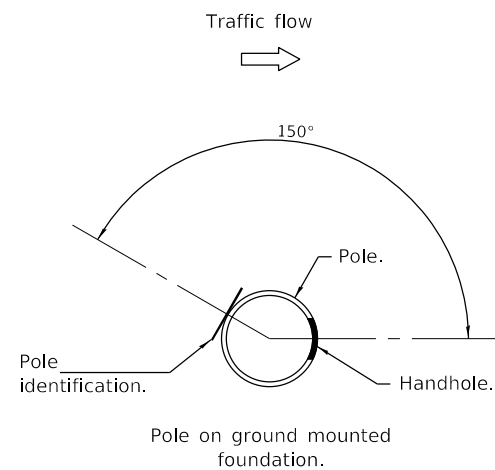
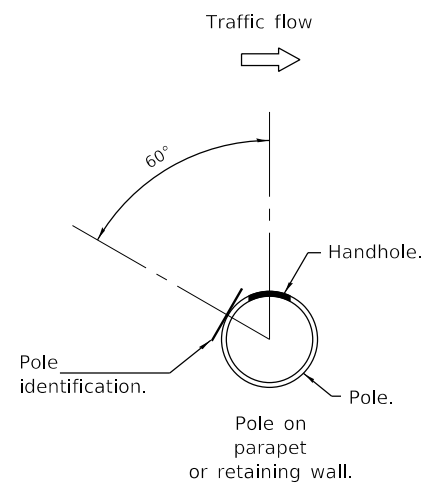

HANDHOLE / IDENTIFICATION ORIENTATION DETAIL

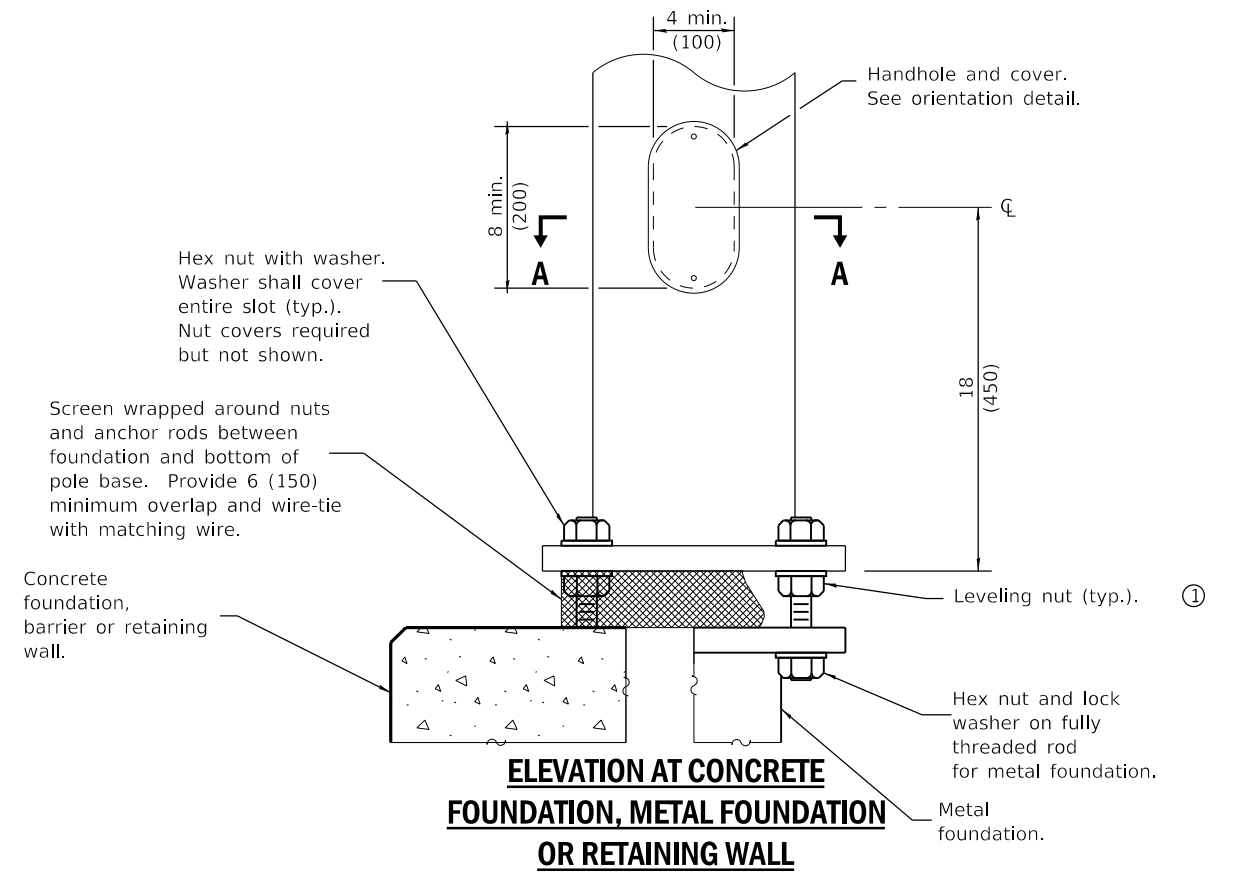
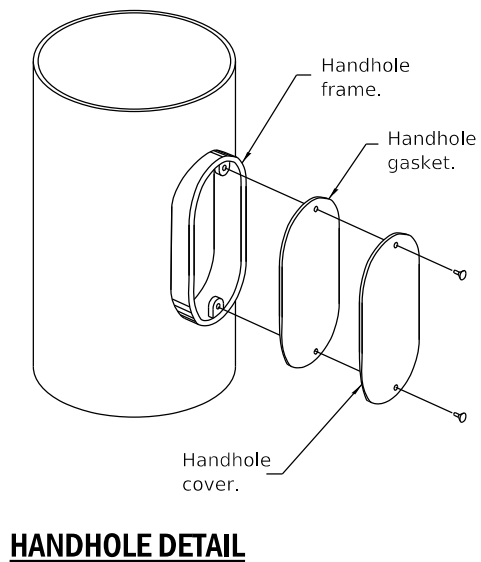
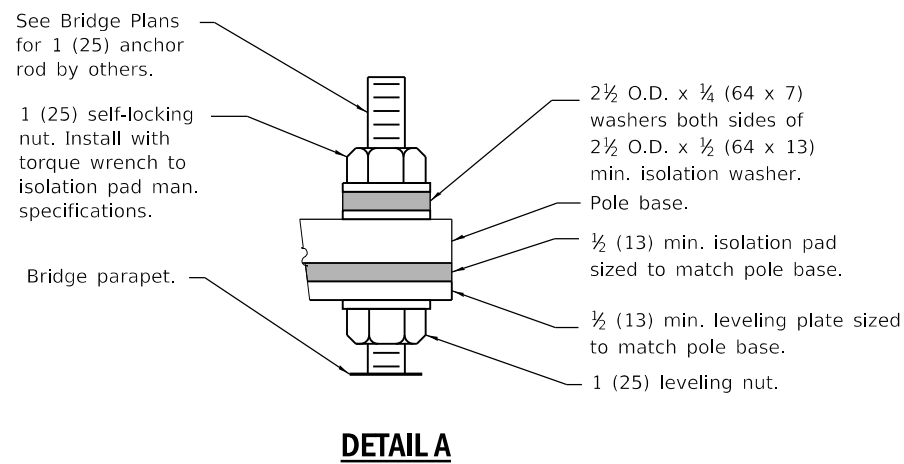
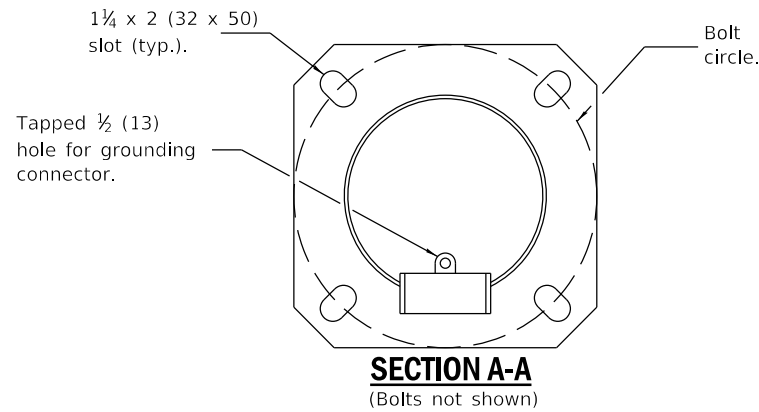

① Omit leveling nuts when breakaway devices are required.

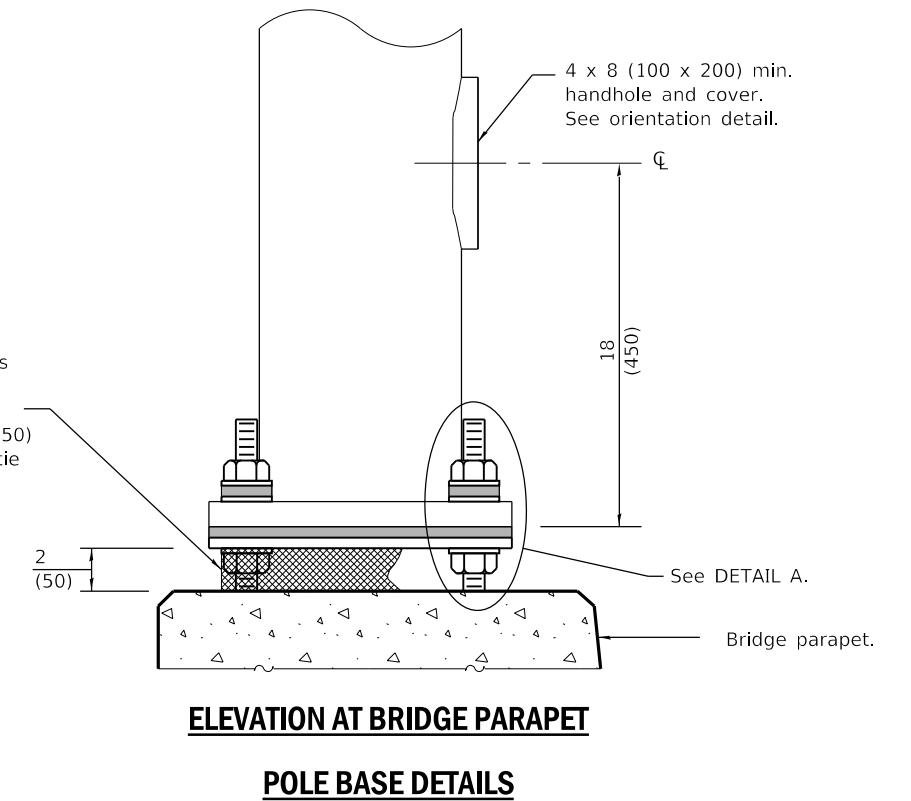

Illinois Department of Transportation

PASSED January 1, 2019

M. E. Reppelt
ELECTRICAL AND MECHANICAL UNIT CHIEF

APPROVED January 1, 2019

J. E. ...
ENGINEER OF DESIGN AND ENVIRONMENT

ISSUED 1-1-12

LIGHT POLE STEEL TENON TOP

(Sheet 2 of 2)

STANDARD 830021-03

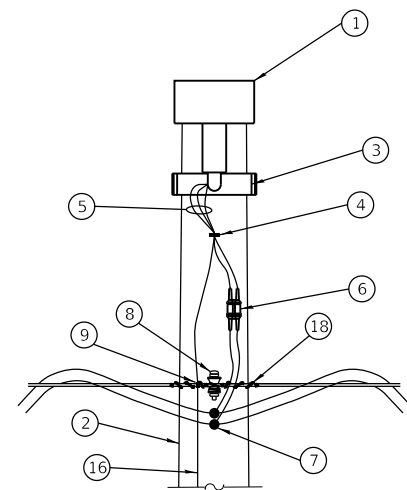

FACING VIEW

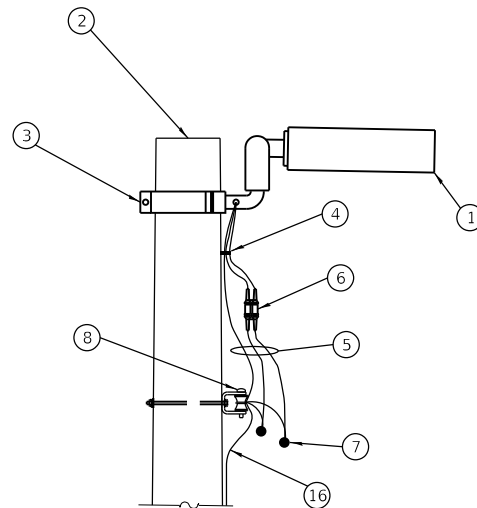

SIDE VIEW

LUMINAIRE MOUNTING DETAILS

43' - 44' (13.1 m - 13.4 m) mounting height unless noted otherwise on plans.

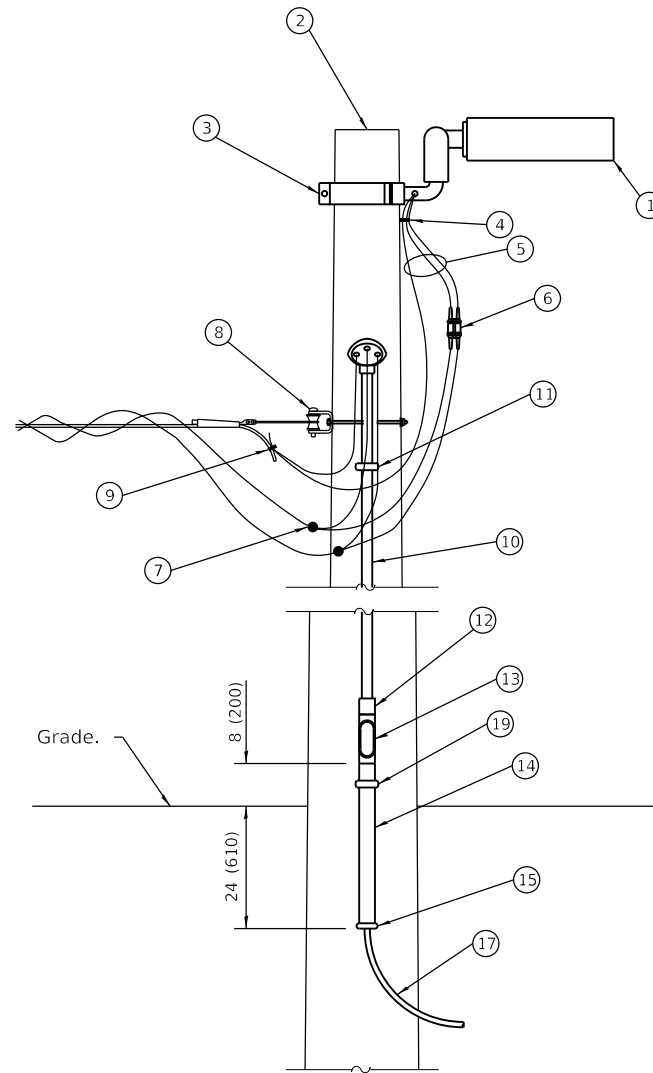

LIGHT POLE WITH CIRCUIT ROUTED UNDERGROUND

- ① Luminaire.
 - ② Wood light pole, 50' (15.2 m), class 3 (typ.). *
 - ③ Luminaire mounting bracket.
 - ④ Cable clamps on 24 (600) centers.
 - ⑤ Three #10 XLP-USE cable.
 - ⑥ Waterproof, two-pole fuse holder with fuses.
 - ⑦ Waterproof insulation piercing tap connector.
 - ⑧ Heavy duty insulated pulley clevis with mounting bolt and hardware.
 - ⑨ Ground clamp.
 - ⑩ 1 (25) rigid steel conduit. *
 - ⑪ Malleable iron conduit clamps, 5' (1.5 m) intervals.
 - ⑫ Threaded conduit reducer.
 - ⑬ "C" conduit, threaded.
 - ⑭ 1½ (40) rigid steel conduit. *
 - ⑮ Conduit bushing.
 - ⑯ #6 Bare copper ground wire to 10 ft. ground rod, every third light pole.
 - ⑰ Unit duct.
 - ⑱ Wire tie.
 - ⑲ Malleable iron conduit clamp below "C" conduit.
- * Size larger as needed.

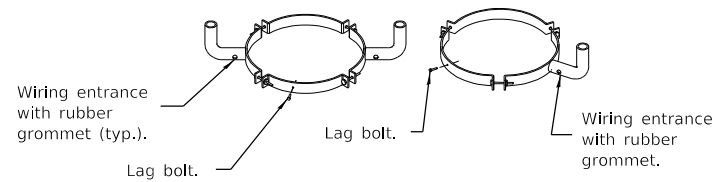

TWIN

SINGLE

MOUNTING BRACKET DETAILS

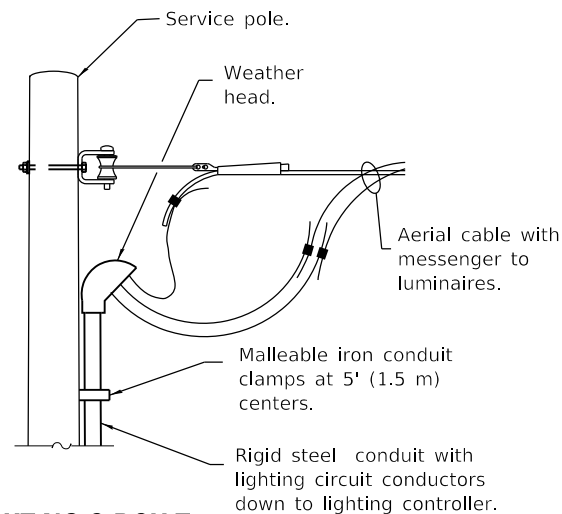

LIGHTING CIRCUIT AT SERVICE/CONTROLLER

See standard 825001 for service installation.

GENERAL NOTES
 See plans for wire and unit duct sizes and pole locations not shown.
 Provide guy wires with strain insulators and anchors, as needed.
 All dimensions are in inches (millimeters) unless otherwise shown.

Illinois Department of Transportation

PASSED January 1, 2019
ME Reppelt
 ELECTRICAL AND MECHANICAL UNIT CHIEF

APPROVED January 1, 2019
J. E. ...
 ENGINEER OF DESIGN AND ENVIRONMENT

ISSUED 1-1-97

DATE	REVISIONS
1-1-19	Revised Luminaire to be horizontal.
1-1-13	New standard.

TEMPORARY ROADWAY LIGHTING

STANDARD 830026-01

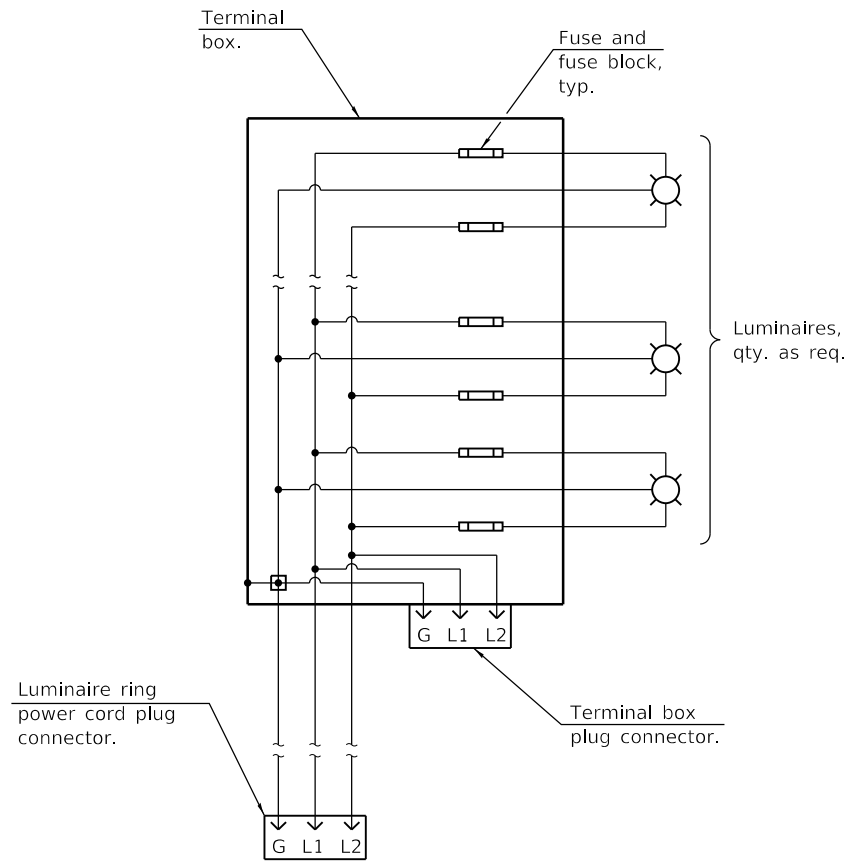

LUMINAIRE RING WIRING DIAGRAM

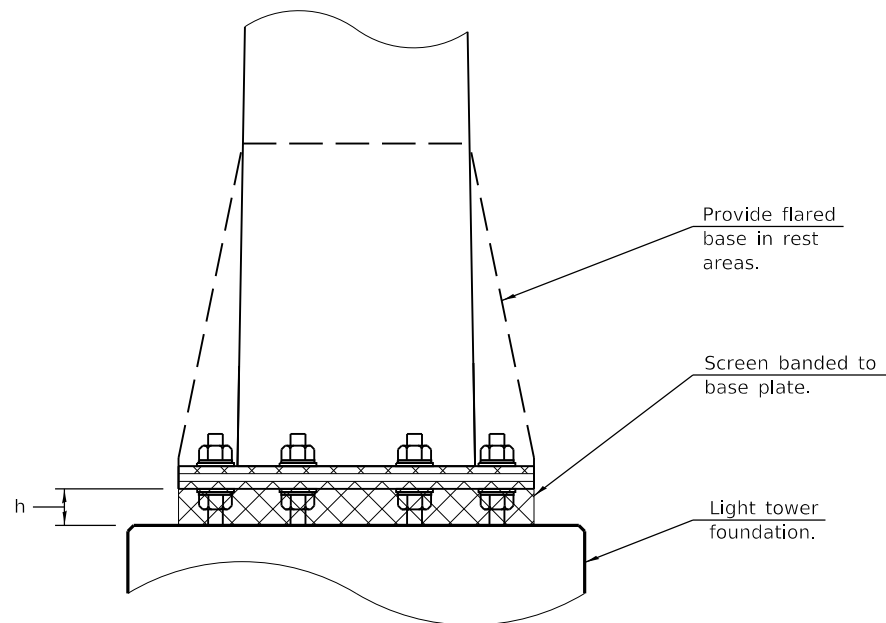

DETAIL A

h = Anchor rod dia. + leveling nut and washer thickness.

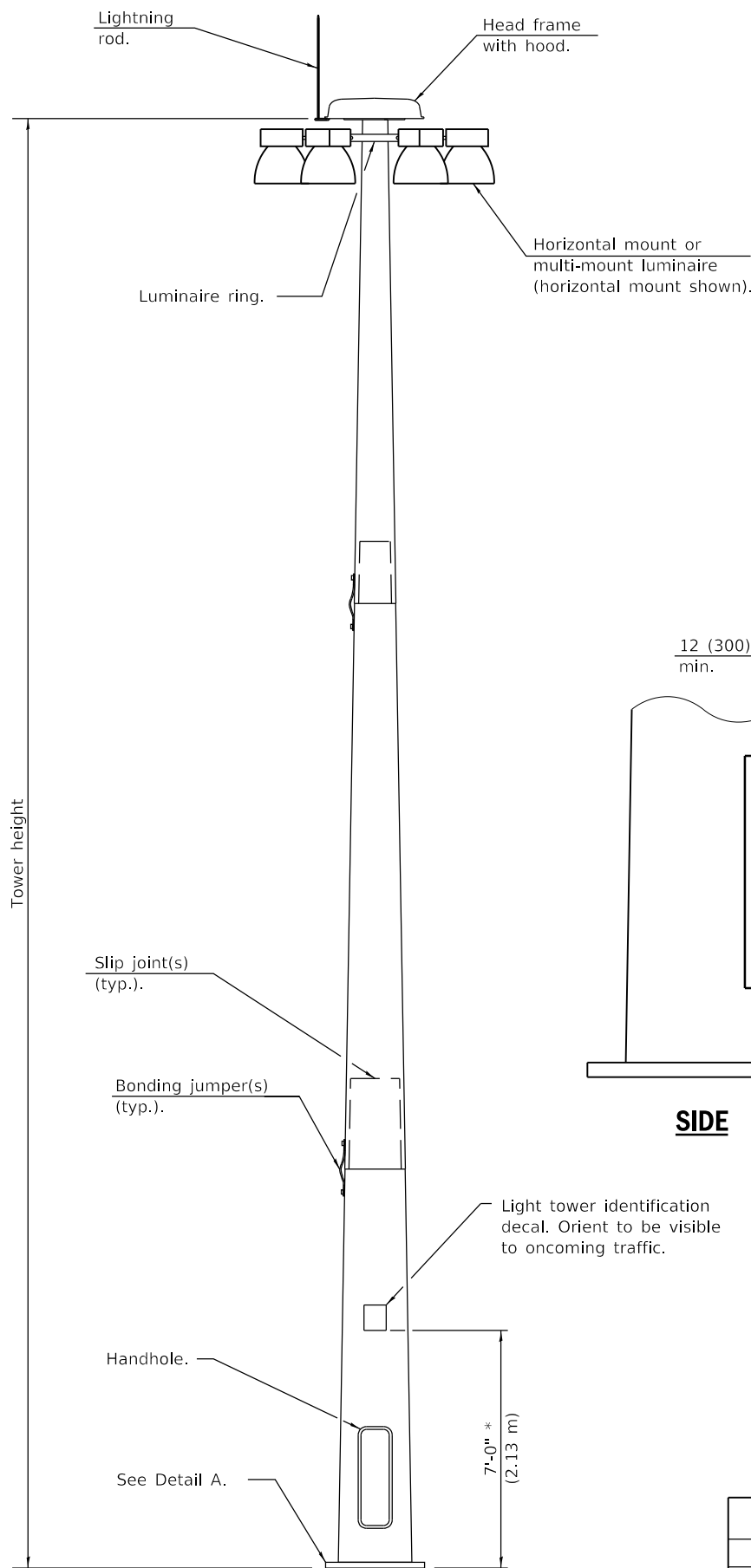

LIGHT TOWER

* Unless directed otherwise by the Engineer.

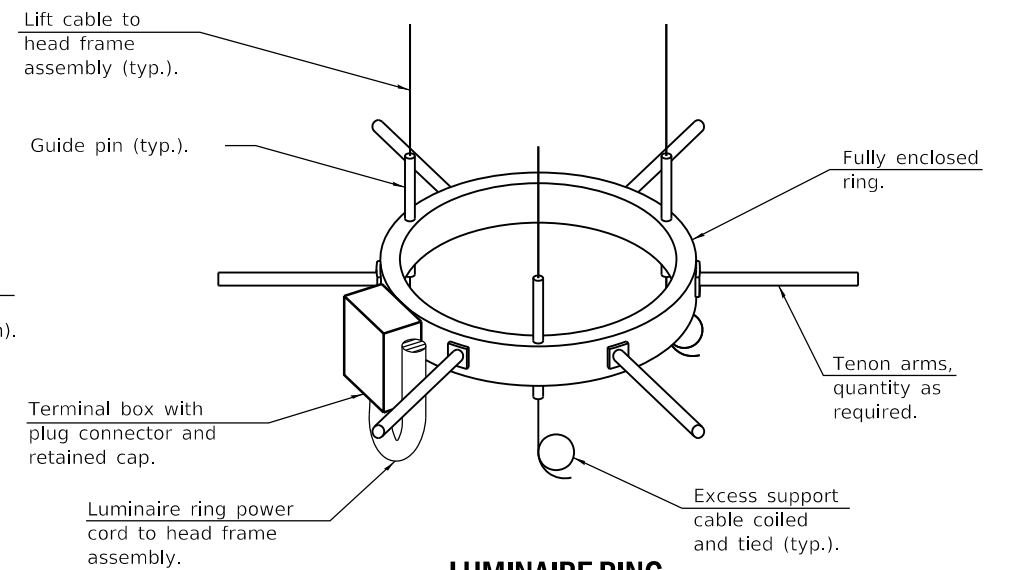

LUMINAIRE RING

(Two or three lift cable system permitted, three lift cable type shown.)

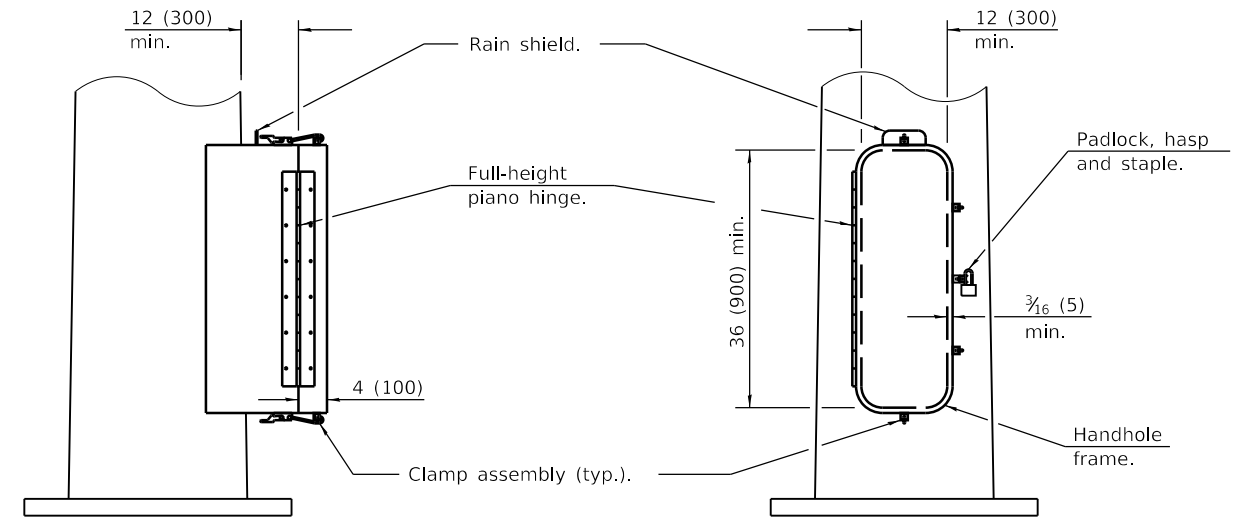

SIDE

FRONT

HANDHOLE

GENERAL NOTES

See Standard 837001 for High Mast Tower Foundation and grounding electrode.

All dimensions are in inches (millimeters) unless otherwise shown.

DATE	REVISIONS
1-1-15	Added light tower identification decal.
	Modified Detail A.
1-1-11	New Standard.

LIGHT TOWER

(Sheet 1 of 2)

STANDARD 835001-01

Illinois Department of Transportation

APPROVED January 1, 2015
Cheryl Gentry
 ENGINEER OF PRELIMINARY ENGINEERING

APPROVED January 1, 2015
[Signature]
 ENGINEER OF DESIGN AND ENVIRONMENT

ISSUED 1-1-11

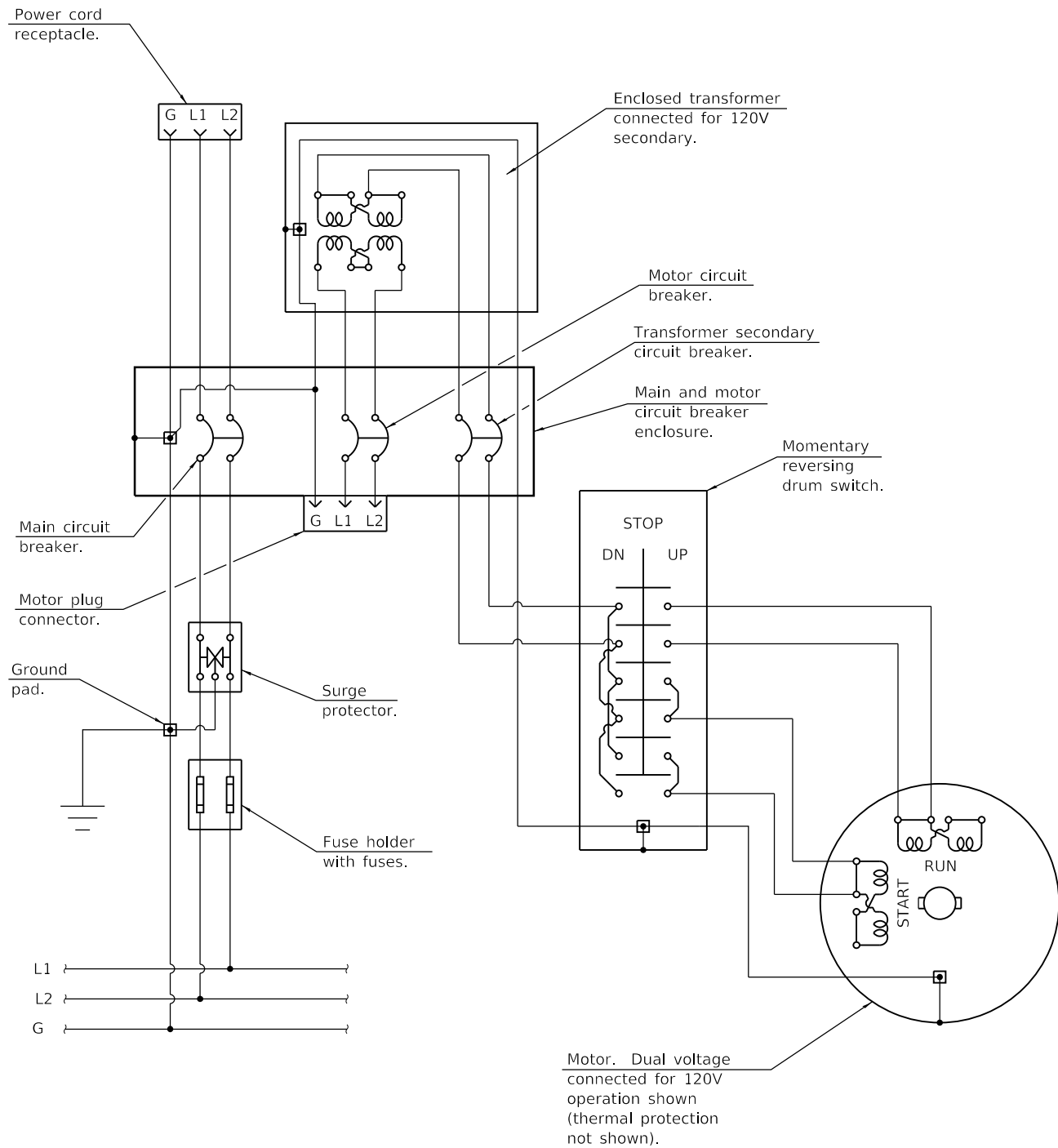

LOWERING SYSTEM WIRING DIAGRAM

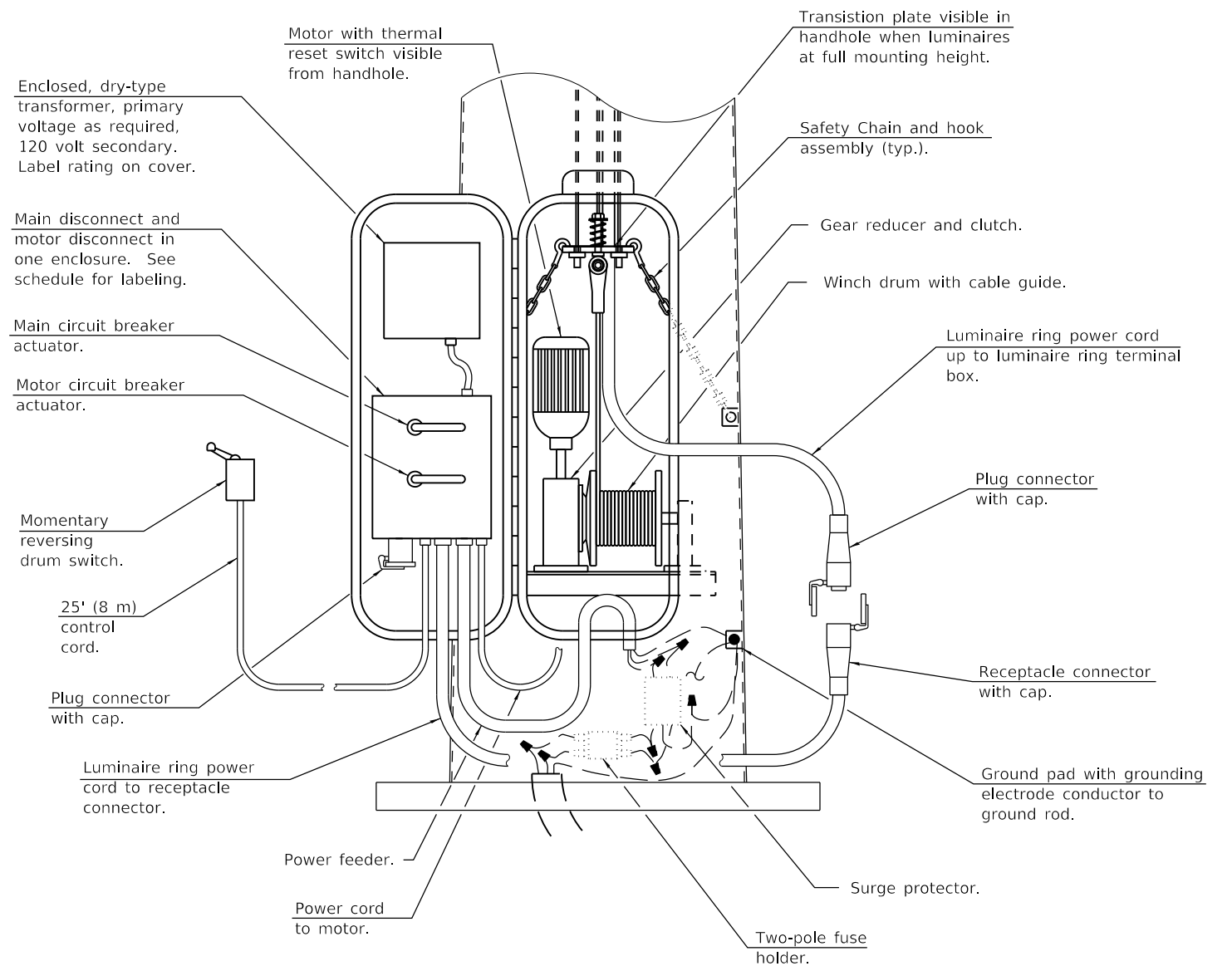

LOWERING AND SUPPORT MECHANISM

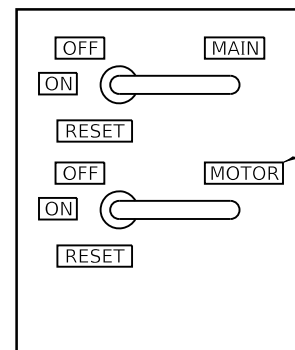

DISCONNECT SCHEDULE

Illinois Department of Transportation

APPROVED January 1, 2015
Cheryl Gentry
 ENGINEER OF PRELIMINARY ENGINEERING

APPROVED January 1, 2015
[Signature]
 ENGINEER OF DESIGN AND ENVIRONMENT

ISSUED 1-11-11

LIGHT TOWER

(Sheet 2 of 2)

STANDARD 835001-01

LIGHT POLE MOUNTING HEIGHT	BOLT CIRCLE DIAMETER	METAL FOUNDATION			CONCRETE FOUNDATION		
		SHAFT DIAMETER	SHAFT DEPTH	TOP PLATE (min)	SHAFT DIAMETER	SHAFT DEPTH	ANCHOR ROD LENGTH
≤30' (9.1 m)	11½ (292)	8⅝ (220)	6' (1.83 m)	12 x 12 x 1 (300 x 300 x 25)	24 (610)	5'-0" (1.52 m)	4'-9" (1.45 m)
31'-35' (9.4 m - 10.7 m)	11½ (292)	8⅝ (220)	6' (1.83 m)	12 x 12 x 1 (300 x 300 x 25)	24 (610)	5'-6" (1.67 m)	5'-3" (1.60 m)
36'-40' (10.9 m - 12.2 m)	15 (381) ②	8⅝ (220)	6' (1.83 m)	15 x 15 x 1¼ (375 x 375 x 31)	30 (762)	6'-0" (1.83 m)	5'-9" (1.75 m)
41'-45' (12.5 m - 13.7 m)	15 (381) ②	8⅝ (220)	6' (1.83 m)	15 x 15 x 1¼ (375 x 375 x 31)	30 (762)	6'-6" (1.98 m)	6'-3" (1.90 m)
46'-50' (14.0 m - 15.2 m)	15 (381) ②	8⅝ (220)	8' (2.44 m)	15 x 15 x 1¼ (375 x 375 x 31)	30 (762)	7'-0" (2.13 m)	6'-9" (2.00 m)

- ① 8⅝ x 8'-0" (220 x 2.44 m) for twin luminaires.
- ② Bolt circle diam. shall be 17 (430) when a transformer base is used.

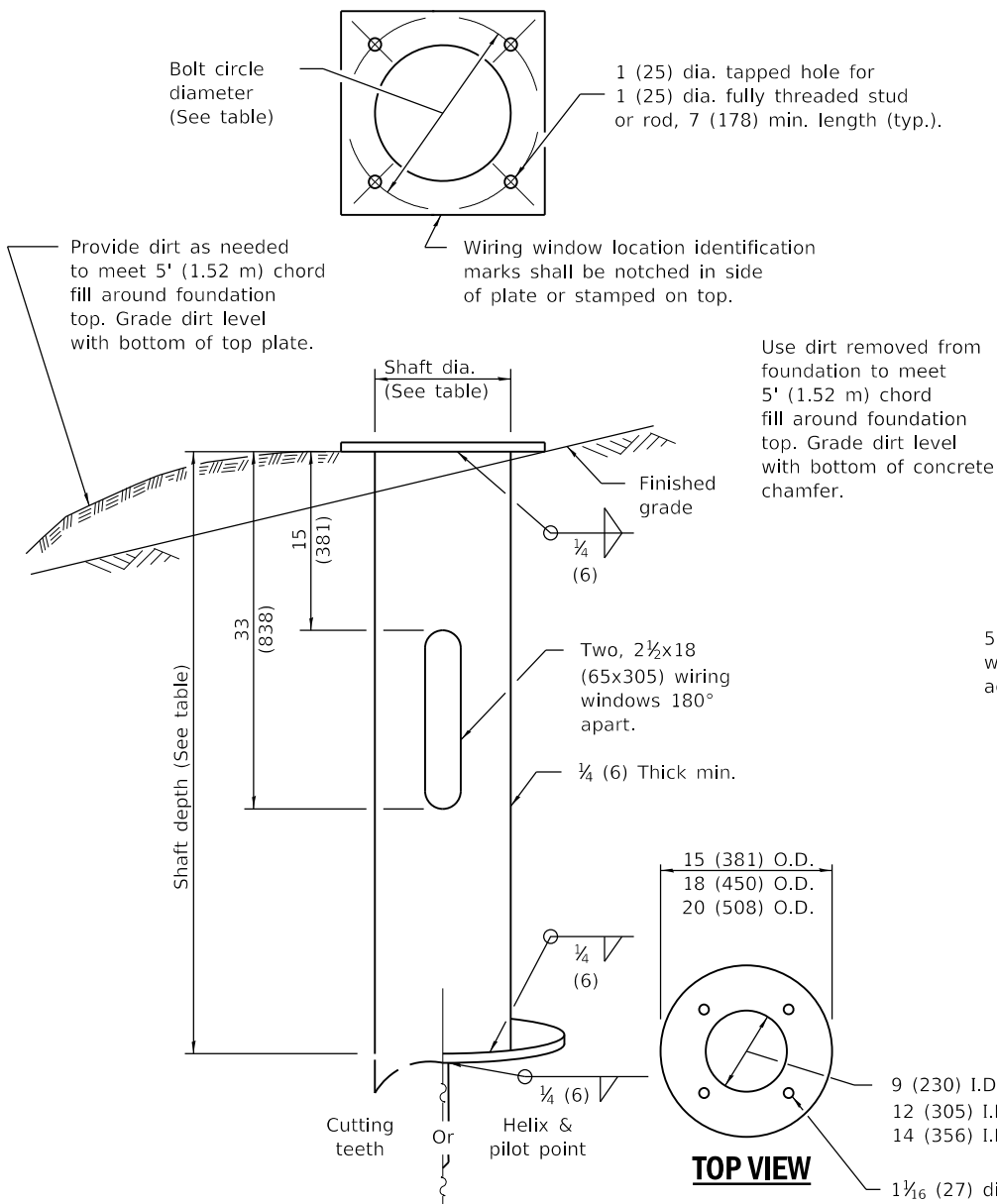

METAL FOUNDATION

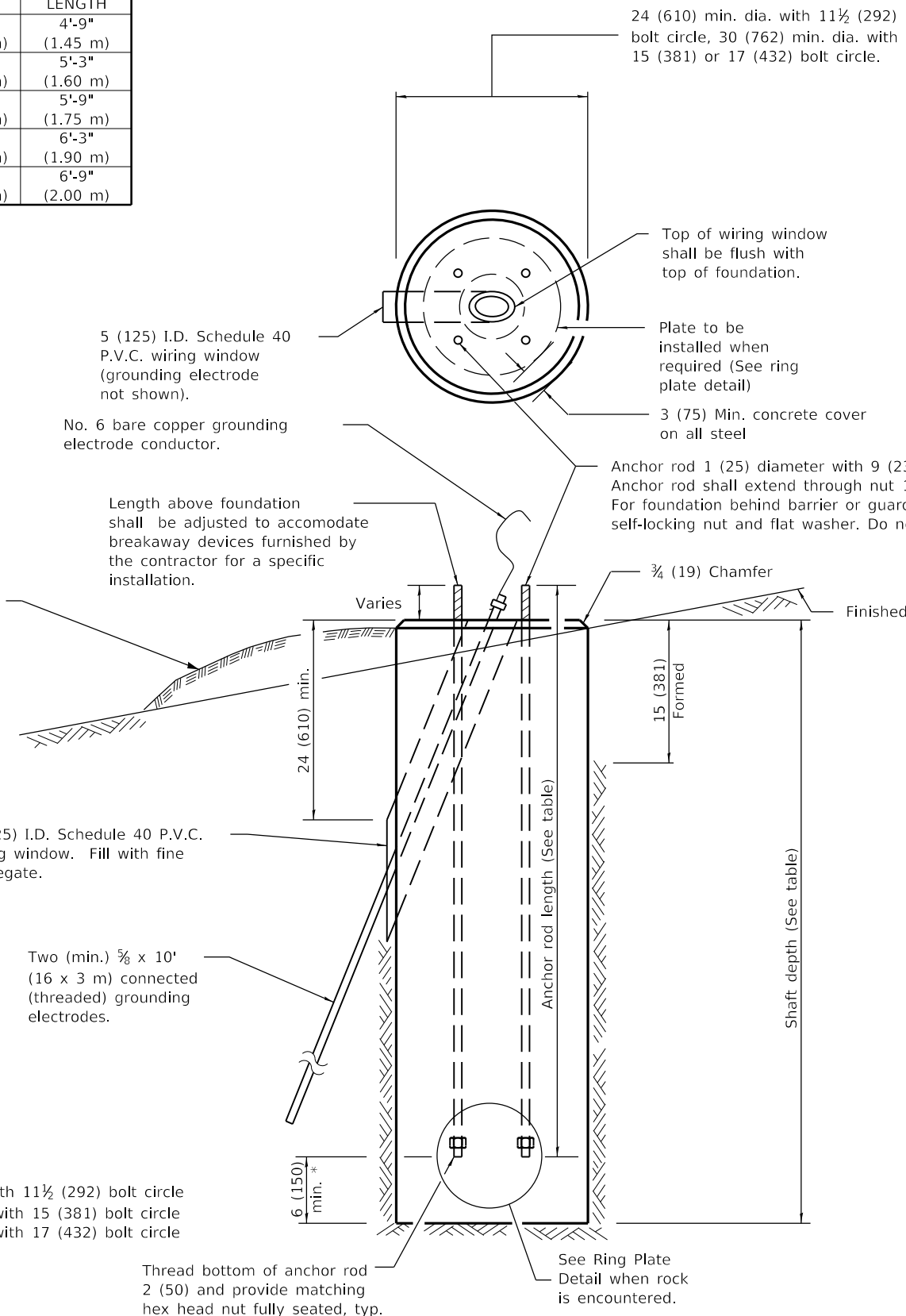
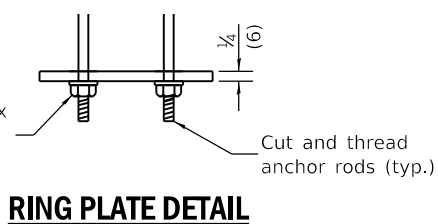

CONCRETE FOUNDATION

* If the required anchor rod length above top of foundation is less than 3 (75), anchor rods may be lowered below 6 (150).

Pole Foundation Setback:
Maximum pole setback shall be 30' (9 m) from edge of pavement and shall be located no closer than 5' (1.5 m) behind guardrail or other protective barriers, or as directed by the Engineer.

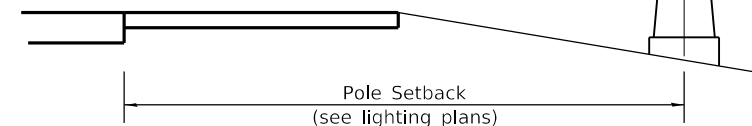

GENERAL NOTES

All foundations are designed to be located on slopes not exceeding 2:1 where soils have an unconfined compressive strength of at least 1.0 TSF. The Contractor shall verify the soil strength during drilling for concrete foundations or by monitoring installation resistance of metal foundations and notify the Engineer if other conditions are encountered.

When rock is encountered the foundation depth may be reduced 6 (150) for every 12 (300) of embedment in rock. The minimum foundation depth shall be 4'-6" (1.37 m) with cut anchor rods 6 (150) above bottom of excavated hole. See ring plate detail.

Anchor rods shall be increased in diameter as needed for 50' (15.2 m) mounting height or above. The Contractor shall match the breakaway device size or slotted hole size in the pole base plate to accommodate larger rod sizes.

Transformer bases shall not be used on metal foundations.

All dimensions are in inches (millimeters) unless otherwise shown.

DATE	REVISIONS
1-1-19	Omitted multimount luminaire to agree with BDE Manual.
1-1-18	Replaced rod hooks with nuts.

LIGHT POLE FOUNDATION

STANDARD 836001-04

Illinois Department of Transportation

PASSED January 1, 2019

ME Reppelt
ELECTRICAL AND MECHANICAL UNIT CHIEF

APPROVED January 1, 2019

ENGINEER OF DESIGN AND ENVIRONMENT

ISSUED 1-1-10

FOUNDATION TABLE				
LIGHT POLE MOUNTING HEIGHT	SHAFT DIAMETER	SHAFT DEPTH	ANCHOR ROD LENGTH	ANCHOR ROD CIRCLE DIA.
≤30' (9.1 m)	24 (610)	36 (914)	6'-2" (1.88 m)	11½ (292)
31'-35' (9.4 m - 10.7 m)	24 (610)	3'-6" (1.06 m)	6'-8" (2.03 m)	11½ (292)
36'-40' (10.9 m - 12.2 m)	30 (762)	4'-0" (1.22 m)	7'-2" (2.18 m)	15 (381)
41'-45' (12.5 m - 13.7 m)	30 (762)	4'-6" (1.37 m)	7'-8" (2.34 m)	15 (381)
46'-50' (14.0 m - 15.2 m)	30 (762)	5'-0" (1.52 m)	8'-2" (2.49 m)	15 (381)

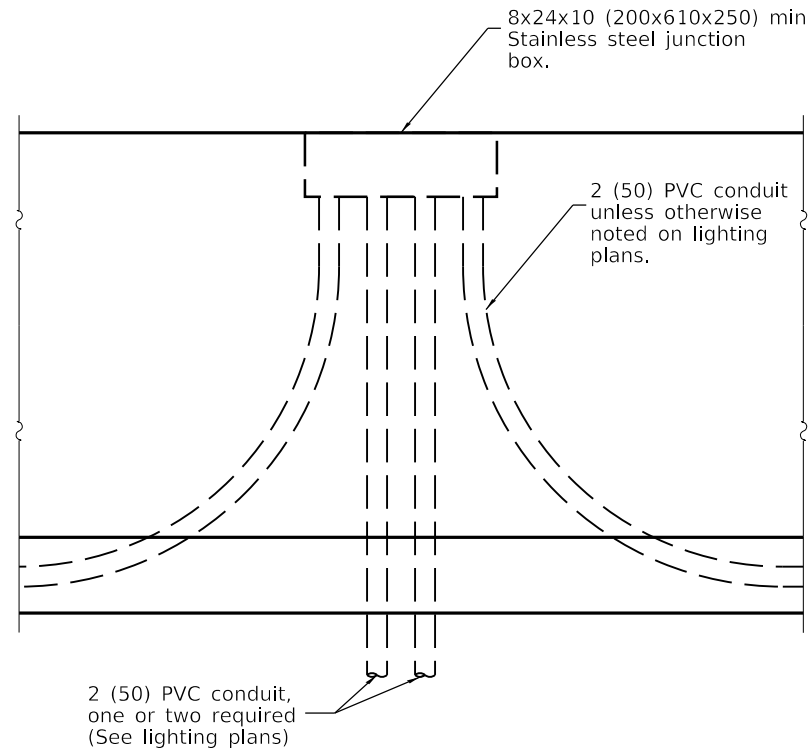
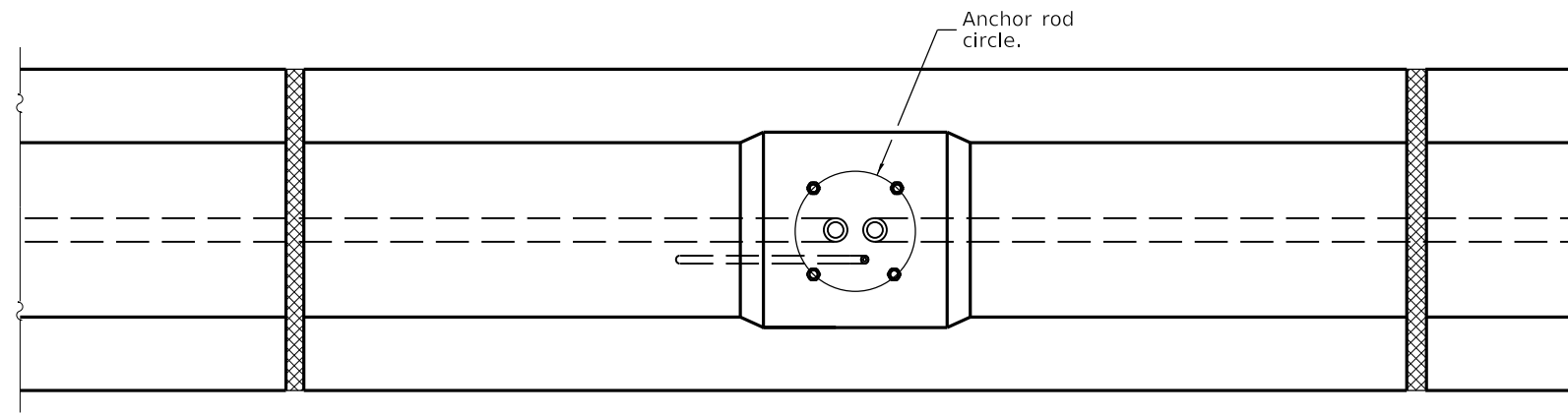

JUNCTION BOX ELEVATION

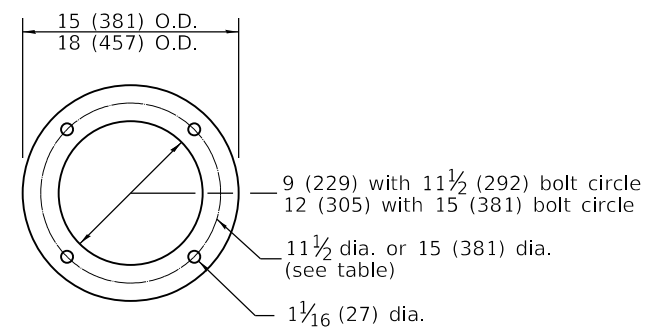

PLAN

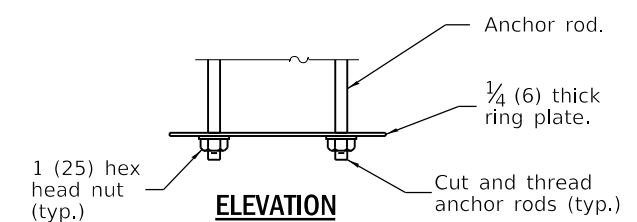

RING PLATE DETAIL ELEVATION

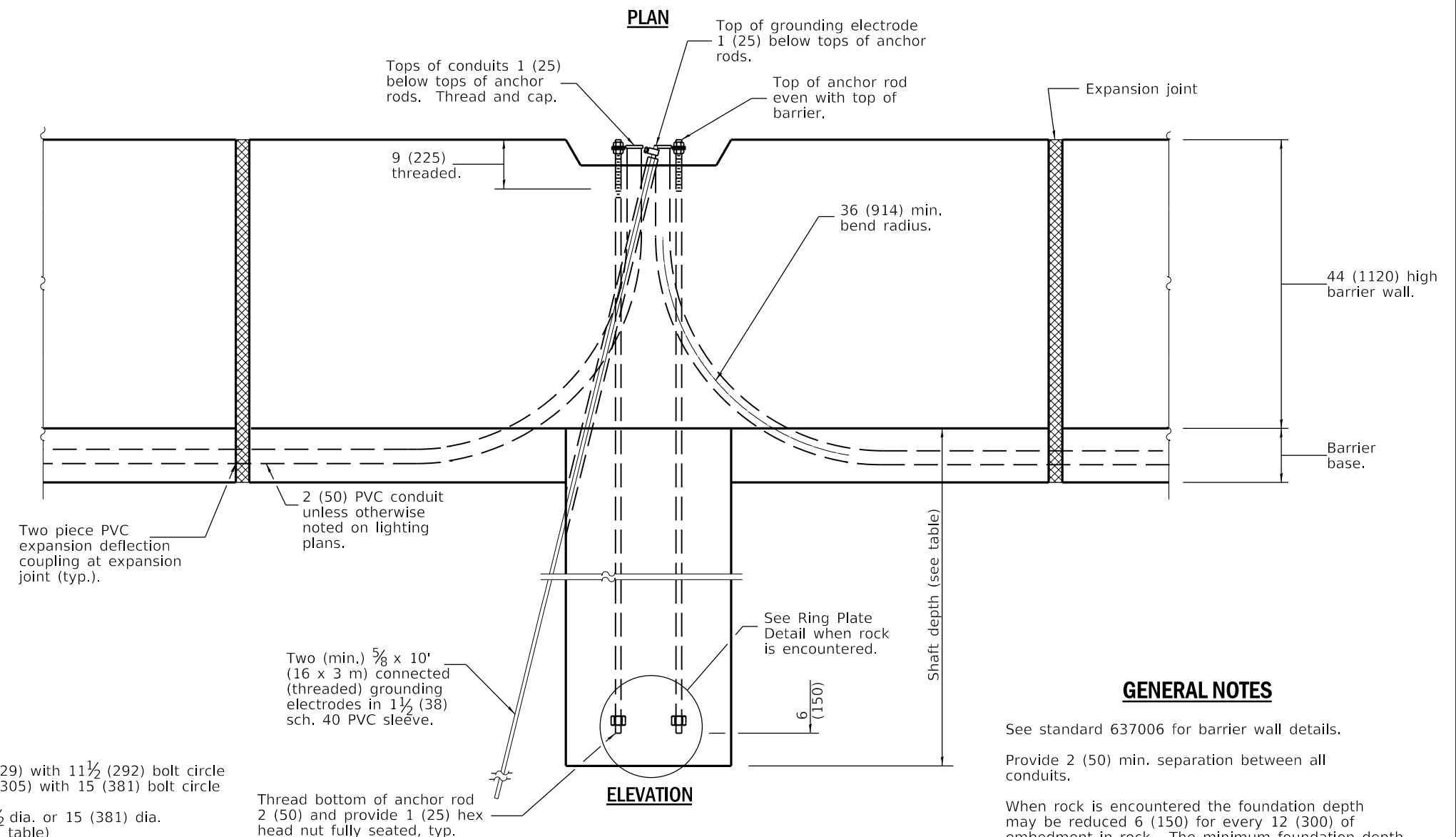

ELEVATION

LIGHT POLE FOUNDATION

GENERAL NOTES

- See standard 637006 for barrier wall details.
- Provide 2 (50) min. separation between all conduits.
- When rock is encountered the foundation depth may be reduced 6 (150) for every 12 (300) of embedment in rock. The minimum foundation depth shall be 30 (760) with cut anchor rods 6 (150) above bottom of excavated hole. See ring plate detail.
- All dimensions are in inches (millimeters) unless otherwise shown.

Illinois Department of Transportation

PASSED January 1, 2019

ME Deppetto
ELECTRICAL AND MECHANICAL UNIT CHIEF

APPROVED January 1, 2019

ENGINEER OF DESIGN AND ENVIRONMENT

ISSUED 1-1-13

DATE	REVISIONS
1-1-19	Revised standard for new constant slope median barrier.
	Renamed standard.
1-1-14	Modified grounding meathod.
	Revised general notes.

LIGHT POLE FOUNDATION WITH 44 IN. (1120 mm) CONCRETE BARRIER

STANDARD 836011-02

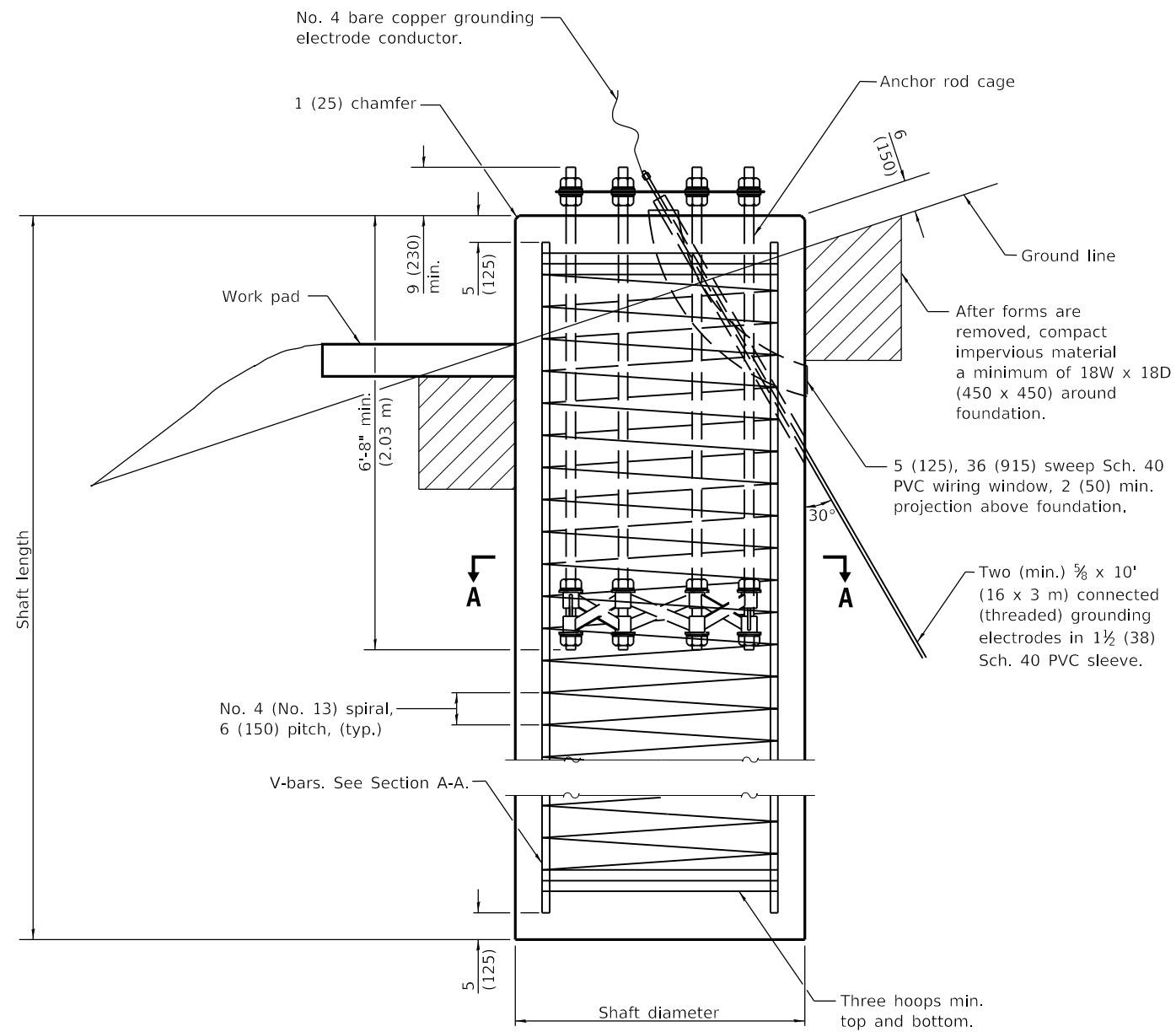

**FOUNDATION
ELEVATION**

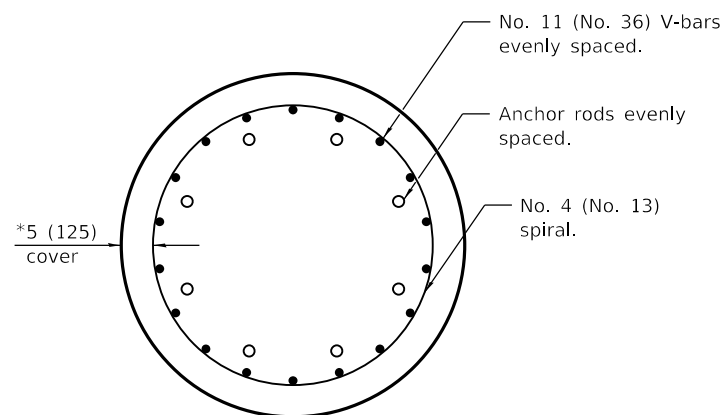

SECTION A-A

* See Rod and Reinforcement Table.

		SHAFT LENGTH TABLE										
SOIL CONSISTENCY		AVERAGE STRENGTH	LIGHT TOWER HEIGHT									
		Qu in tsf (Qu in kPa)	80' (24 m)	90' (27 m)	100' (30 m)	110' (34 m)	120' (37 m)	130' (40 m)	140' (43 m)	150' (46 m)	160' (49 m)	
Cohesive	SOFT	< 0.5 (< 50)	20'-6" (6.2 m)	21'-6" (6.5 m)	22'-6" (6.9 m)	24'-0" (7.2 m)	25'-0" (7.6 m)	26'-6" (8.0 m)	27'-6" (8.3 m)	28'-6" (8.7 m)	30'-0" (9.1 m)	
	MEDIUM	0.5 to 1 (50 to 100)	17'-0" (5.1 m)	17'-6" (5.3 m)	18'-6" (5.6 m)	19'-0" (5.8 m)	20'-6" (6.2 m)	21'-6" (6.4 m)	22'-0" (6.7 m)	23'-6" (7.0 m)	24'-0" (7.3 m)	
	STIFF	1 to 2 (100 to 200)	14'-6" (4.4 m)	15'-0" (4.5 m)	15'-6" (4.7 m)	16'-0" (4.8 m)	17'-6" (5.2 m)	18'-0" (5.4 m)	18'-6" (5.5 m)	19'-6" (5.9 m)	20'-0" (6.1 m)	
	VERY STIFF	2 to 4 (200 to 400)	13'-0" (3.8 m)	13'-0" (3.9 m)	13'-6" (4.1 m)	14'-0" (4.2 m)	15'-0" (4.5 m)	15'-6" (4.6 m)	16'-0" (4.7 m)	17'-0" (5.1 m)	17'-6" (5.2 m)	
	HARD	> 4 (> 400)	11'-6" (3.5 m)	12'-0" (3.5 m)	12'-0" (3.6 m)	12'-6" (3.7 m)	13'-6" (4.0 m)	13'-6" (4.1 m)	14'-0" (4.2 m)	15'-0" (4.5 m)	15'-6" (4.6 m)	
		N in BLOWS/FT. (N in BLOWS/0.3m)										
Granular	VERY LOOSE	< 5 (< 5)	16'-6" (5.0 m)	17'-6" (5.2 m)	18'-0" (5.4 m)	18'-6" (5.6 m)	19'-0" (5.8 m)	20'-0" (6.0 m)	20'-6" (6.2 m)	21'-0" (6.3 m)	21'-6" (6.5 m)	
	LOOSE	5 to 10 (5 to 10)	15'-0" (4.6 m)	16'-0" (4.8 m)	16'-6" (4.9 m)	17'-0" (5.1 m)	17'-6" (5.3 m)	18'-0" (5.5 m)	18'-6" (5.6 m)	19'-0" (5.7 m)	19'-6" (5.9 m)	
	MEDIUM	10 to 25 (10 to 25)	14'-6" (4.4 m)	15'-0" (4.5 m)	15'-6" (4.7 m)	16'-0" (4.9 m)	16'-6" (5.0 m)	17'-0" (5.2 m)	17'-6" (5.3 m)	18'-0" (5.5 m)	18'-6" (5.6 m)	
	DENSE	25 to 50 (25 to 50)	14'-0" (4.1 m)	14'-6" (4.3 m)	15'-0" (4.5 m)	15'-6" (4.6 m)	15'-6" (4.7 m)	16'-6" (4.9 m)	16'-6" (5.0 m)	17'-0" (5.2 m)	17'-6" (5.3 m)	
	VERY DENSE	> 50 (> 50)	13'-0" (3.9 m)	13'-6" (4.1 m)	14'-0" (4.2 m)	14'-6" (4.4 m)	15'-0" (4.5 m)	15'-6" (4.7 m)	16'-0" (4.8 m)	16'-6" (4.9 m)	17'-0" (5.1 m)	

See Sheet 2 for GENERAL NOTES.

DATE	REVISIONS
1-1-20	Revised min. anchor rod diameters.
1-1-15	Added 6'-8" min. anchor rod embedment in foundation.
1-1-14	Revised diameter of grounding electrode sleeve.

**LIGHT TOWER
FOUNDATION**

(Sheet 1 of 2)

STANDARD 837001-05

Illinois Department of Transportation

APPROVED January 1, 2020
ME Reppelt
 ELECTRICAL AND MECHANICAL UNIT CHIEF

APPROVED January 1, 2020
J. E. ...
 ENGINEER OF DESIGN AND ENVIRONMENT

ISSUED 1-1-10

ROD AND REINFORCEMENT TABLE					
TOWER HEIGHT	ANCHOR ROD DIAM. (MIN)	ROD CIRCLE DIAM. (MIN)	TOWER BASE DIAM. (MIN)	DRILLED SHAFT DIAM. ①	V BAR QTY.
80' (25 m)	1½ (38)	30 (760)	24 (610)	4'-0" (1.2 m)	14
90' (27 m)	1¾ (44)	30 (760)	24 (610)	4'-0" (1.2 m)	14
100' (30 m)	1¾ (44)	30 (760)	24 (610)	4'-0" (1.2 m)	14
110' (34 m)	2 (51)	30 (760)	24 (610)	4'-0" (1.2 m)	14
120' (37 m)	2 (51)	36 (915)	26 (660)	4'-6" (1.4 m)	18
130' (40 m)	2¼ (57)	36 (915)	28 (710)	4'-6" (1.4 m)	18
140' (43 m)	2¼ (57)	36 (915)	28 (710)	4'-6" (1.4 m)	18
150' (46 m)	2½ (57)	38 (965)	30 (760)	5'-0" (1.5 m)	22
160' (49 m)	2½ (64)	38 (965)	32 (810)	5'-0" (1.5 m)	22

① Diameter based on a 5 (125) conc. cover. The min. cover shall be 3 (75) in dry shaft excavation and 4 (100) in a wet hole. When rock is encountered a 5 (125) cover against soil and a 2 (50) cover against rock shall be required.

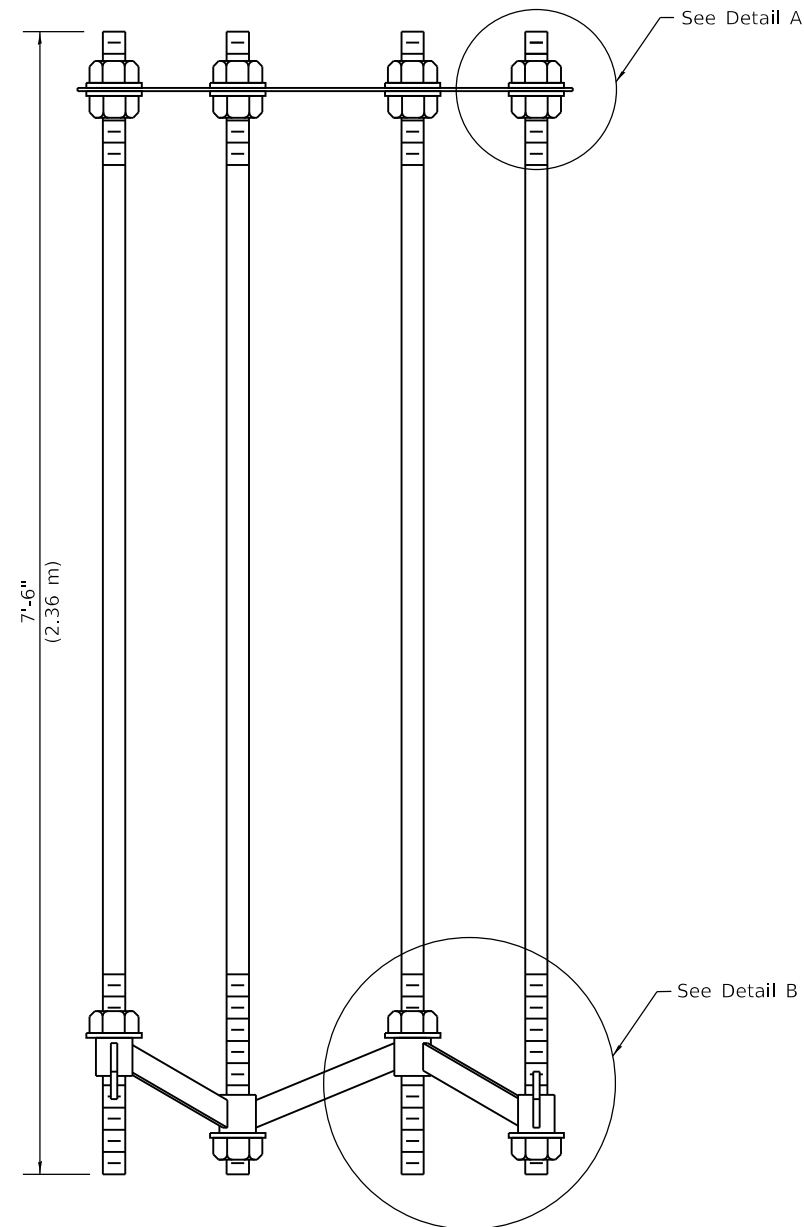

SECTION B-B

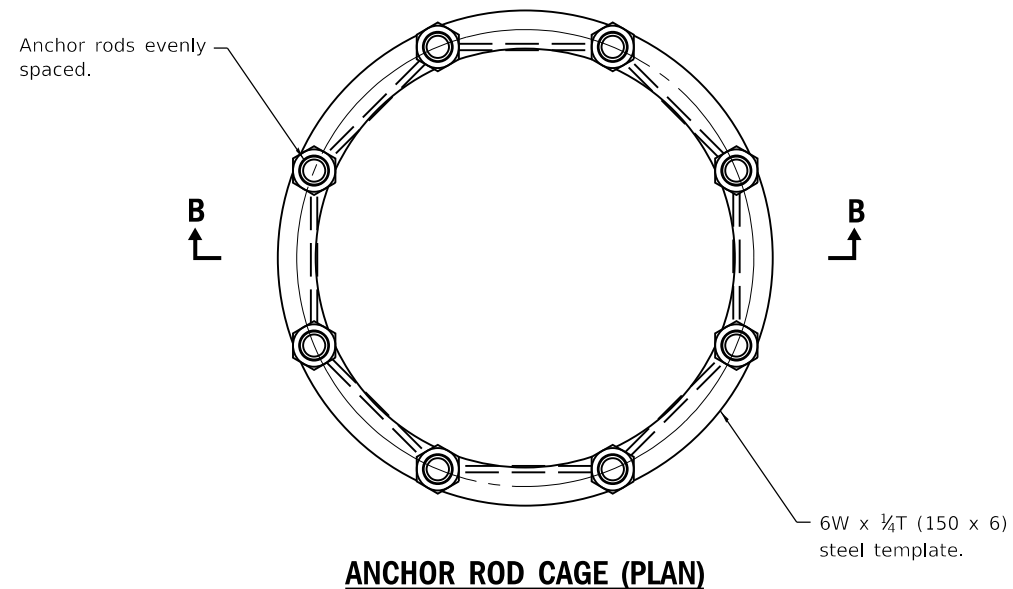

ANCHOR ROD CAGE (PLAN)

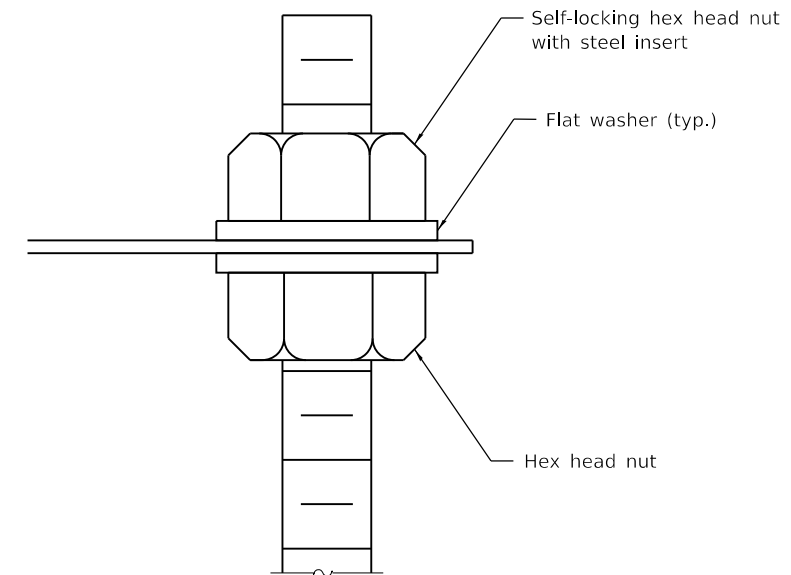

DETAIL A

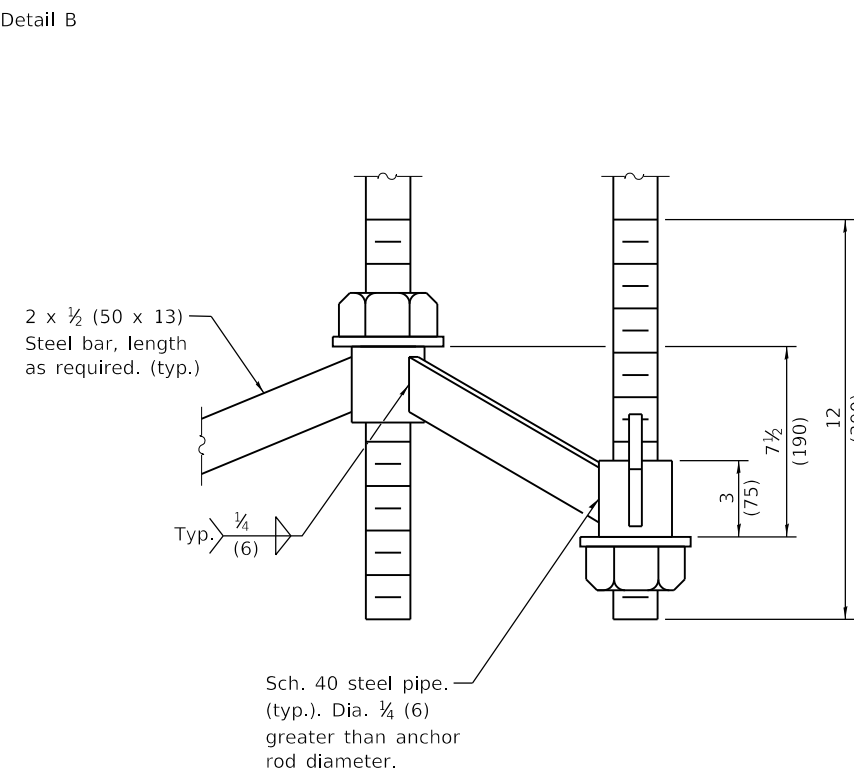

DETAIL B

GENERAL NOTES

The shaft length(s) are based on soil borings in the plans. If different soils are encountered, the engineer shall be notified to provide a revised length.

Anchor rod quantity, diameter, and length shall be determined by the tower manufacturer and approved by the Engineer. Each foundation shall have a minimum of 8 anchor rods.

All foundation reinforcement steel shall be epoxy coated.

The cost of reinforcement shall be included in the cost of the foundation.

Steel anchor rod forms shall not be removed for a minimum of 3 days after concrete is poured. The tower shall not be set for a minimum of 7 days or as approved by the Engineer.

Coordinate the rod circle diameter of the tower with the diameter of the anchor rod cage.

The foundation shall be poured monolithically and shall have no construction joints.

Grounding electrodes shall be installed in an access well when there is a conflict in using the method shown.

All dimensions are in inches (millimeters) unless otherwise shown.

LIGHT TOWER FOUNDATION

(Sheet 2 of 2)

STANDARD 837001-05

Illinois Department of Transportation

APPROVED January 1, 2020
ME Reppelt
 ELECTRICAL AND MECHANICAL UNIT CHIEF

APPROVED January 1, 2020
J. E. ...
 ENGINEER OF DESIGN AND ENVIRONMENT

ISSUED 1-1-10

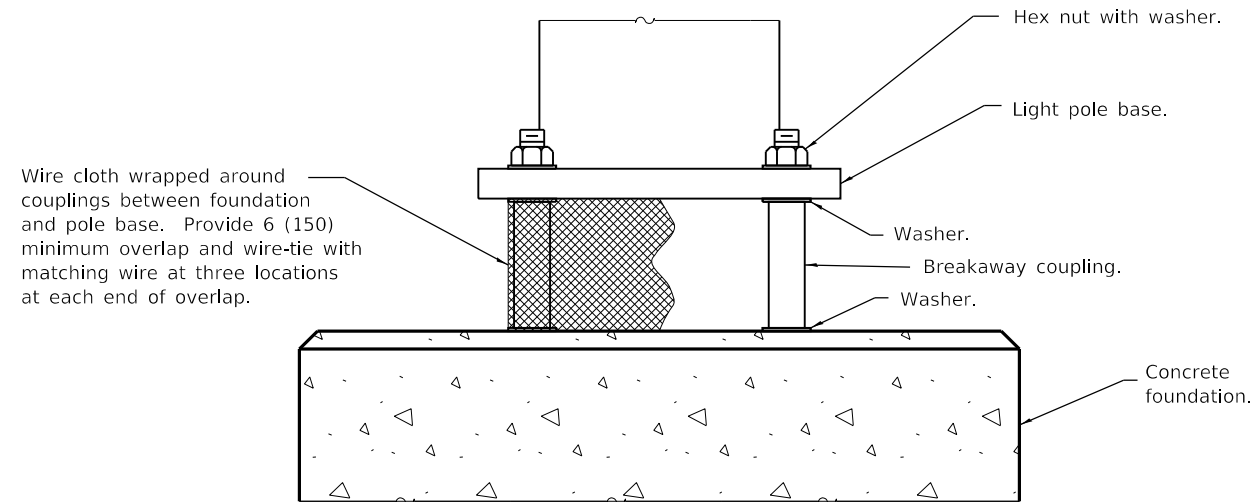

**BREAKAWAY COUPLINGS ON CONCRETE
FOUNDATION FOR STEEL LIGHT POLE**

(Provide pole base skirt around wire cloth when required.)

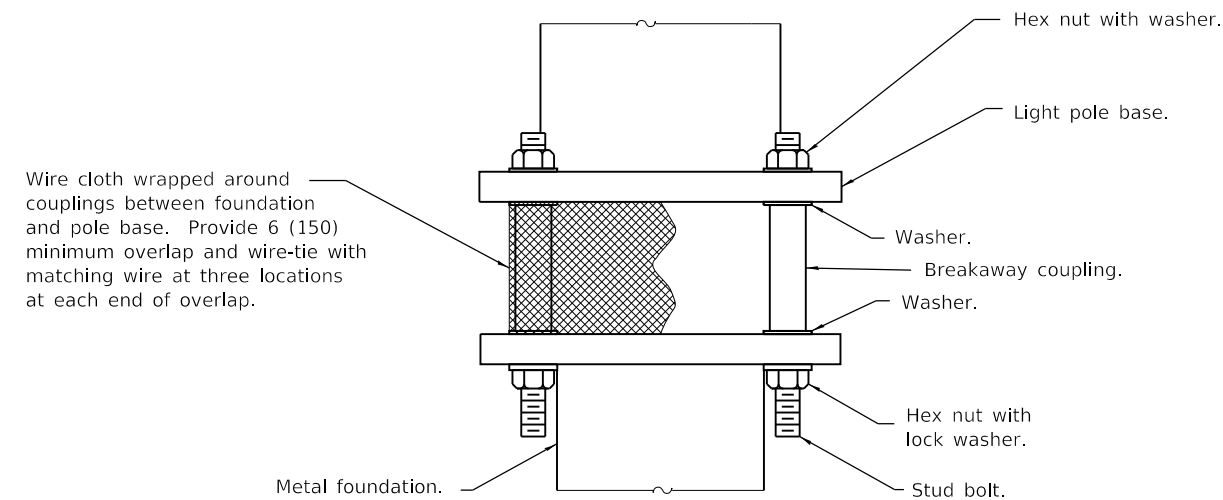

**BREAKAWAY COUPLINGS ON METAL
FOUNDATION FOR STEEL POLE**

(Provide pole base skirt around wire cloth when required.)

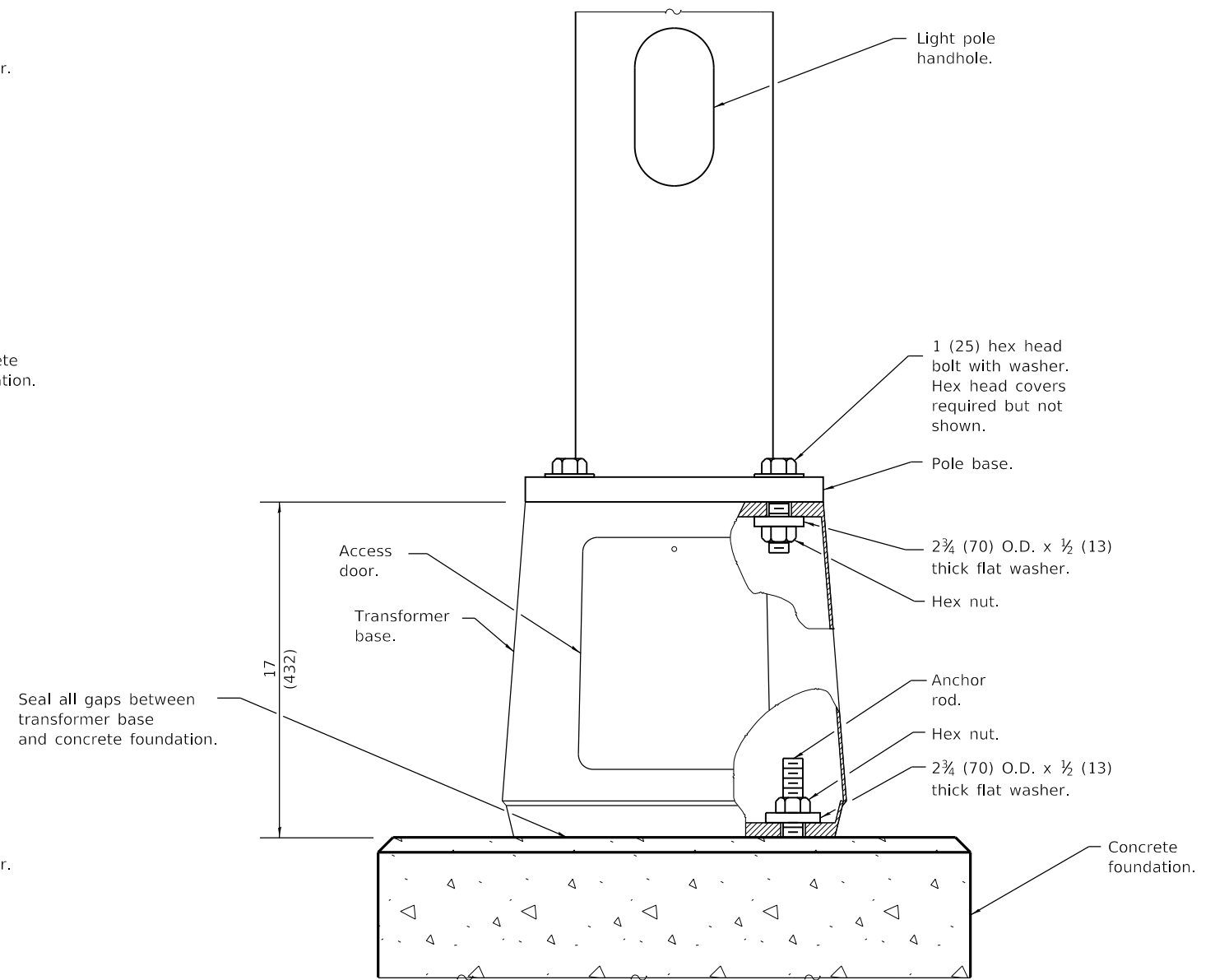

**BREAKAWAY TRANSFORMER BASE FOR
STEEL OR ALUMINUM POLE**

(Steel pole shown)

See Sheet 2 for GENERAL NOTES.

Illinois Department of Transportation

PASSED January 1, 2018
[Signature]
 ENGINEER OF PRELIMINARY ENGINEERING

APPROVED January 1, 2018
[Signature]
 ENGINEER OF DESIGN AND ENVIRONMENT

ISSUED 1-1-12

DATE	REVISIONS
1-1-18	Revised to show rodent shield installation for aluminum poles.
1-1-14	New Standard.

BREAKAWAY DEVICES

(Sheet 1 of 2)

STANDARD 838001-01

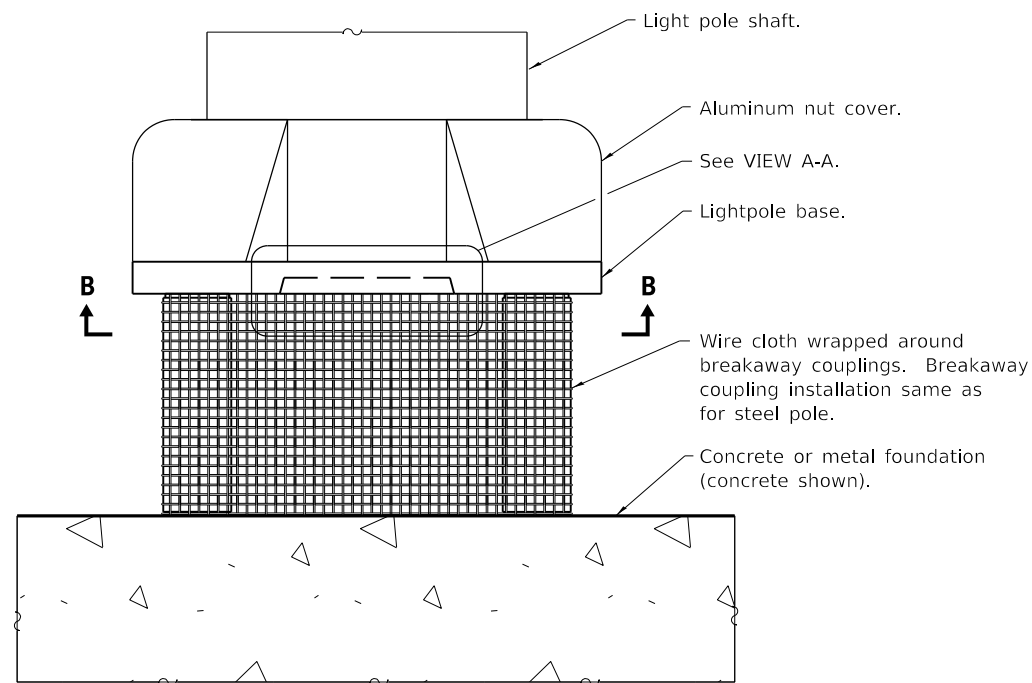
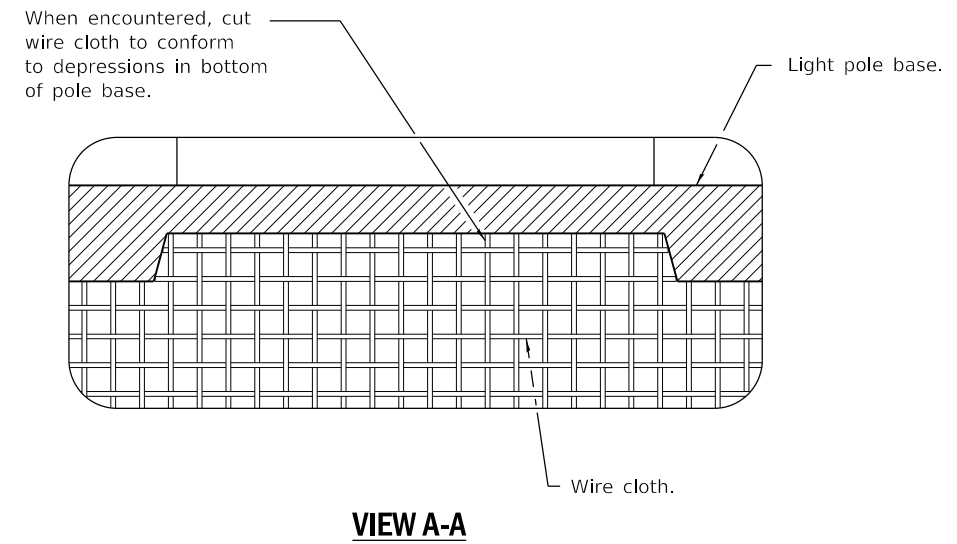
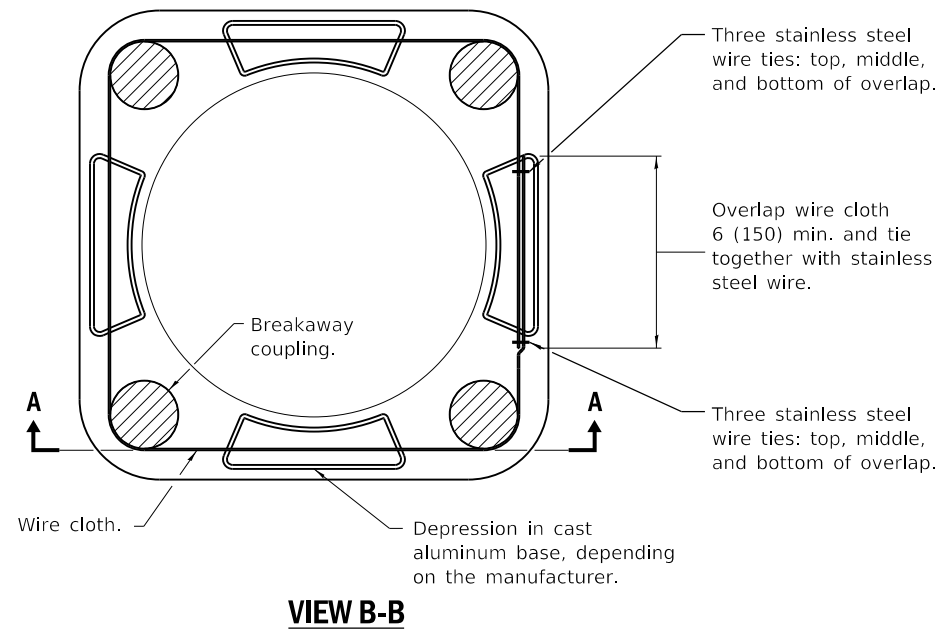

BREAKAWAY COUPLINGS FOR ALUMINUM POLES

(Provide pole base skirt around wire cloth when required.)

GENERAL NOTES

- See light pole standard for details not shown.
- Use largest transformer base bolt circle possible.
- Transformer bases shall not be installed on metal foundations.
- Washers on top of pole base shall cover the entire bolt slot.
- See Standard 836001 for Light Pole Foundation.
- Wire cloth shall be stainless steel, have a maximum opening of $\frac{1}{4}$ (6), and have a minimum wire size of AWG No. 16 (1.6).
- All dimensions are in inches (millimeters) unless otherwise shown.

Illinois Department of Transportation

PASSED January 1, 2018
[Signature]
 ENGINEER OF PRELIMINARY ENGINEERING

ISSUED 1-1-12

APPROVED January 1, 2018
[Signature]
 ENGINEER OF DESIGN AND ENVIRONMENT

BREAKAWAY DEVICES

(Sheet 2 of 2)

STANDARD 838001-01

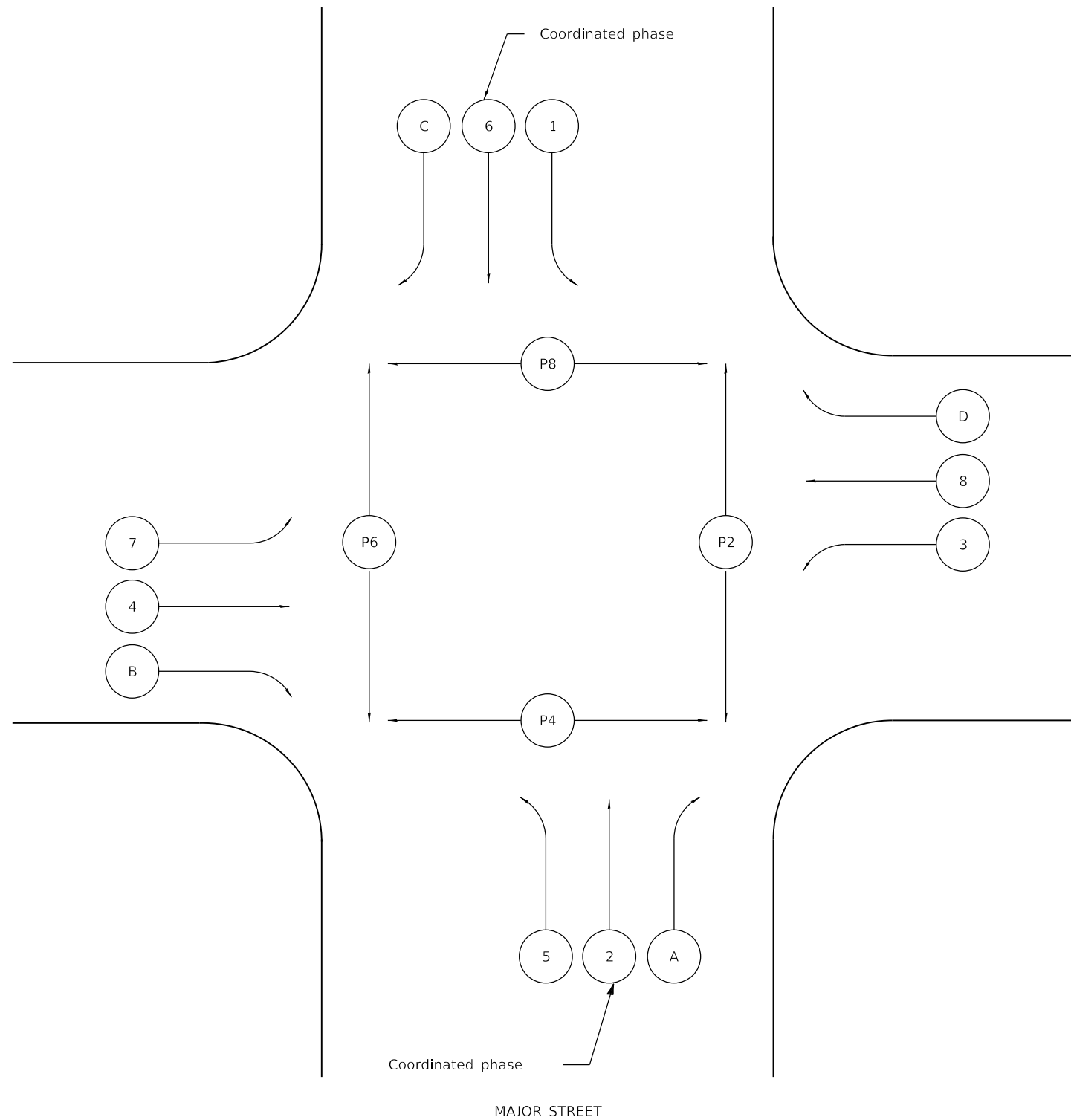

STANDARD PHASE DESIGNATION DIAGRAM (NEMA)

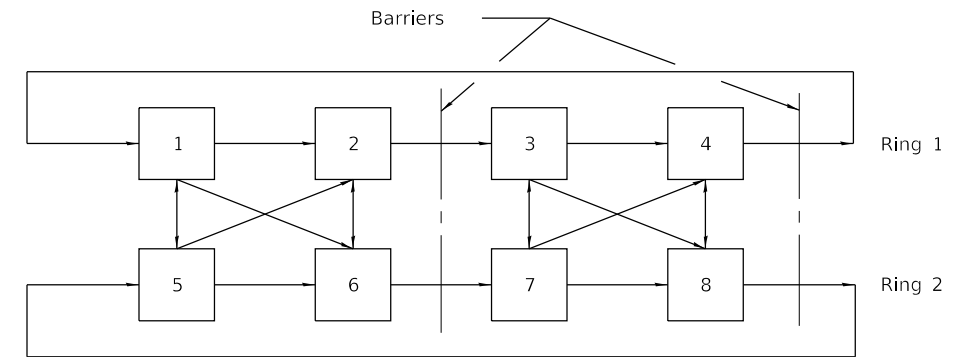

**NEMA EIGHT PHASE DUAL RING
ACTUATED CONFIGURATION**

LEGEND

- (X), [X] Vehicular phase no. x
- (PX) Pedestrian phase no. x
- (A), (B), (C), (D) Right turn overlaps where:
 - (A) = (2) + (3)
 - (B) = (4) + (5)
 - (C) = (6) + (7)
 - (D) = (8) + (1)
- NEMA National Electrical Manufacturers Association

Illinois Department of Transportation

PASSED January 1, 2009
[Signature]
 ENGINEER OF OPERATIONS

APPROVED January 1, 2009
[Signature]
 ENGINEER OF DESIGN AND ENVIRONMENT

ISSUED 1-1-97

DATE	REVISIONS
1-1-09	Omitted note regarding units of length.
1-1-97	Renum. Standard 2393-2.

**STANDARD PHASE
DESIGNATION DIAGRAMS
AND PHASE SEQUENCES**
 (Sheet 1 of 2)

STANDARD 857001-01

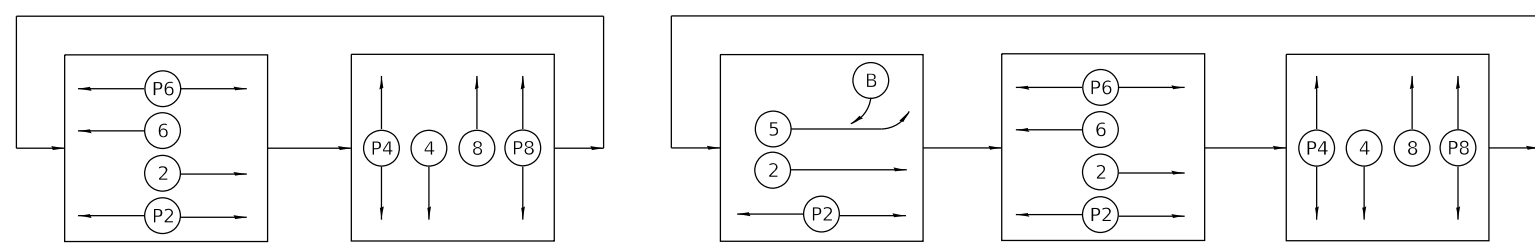
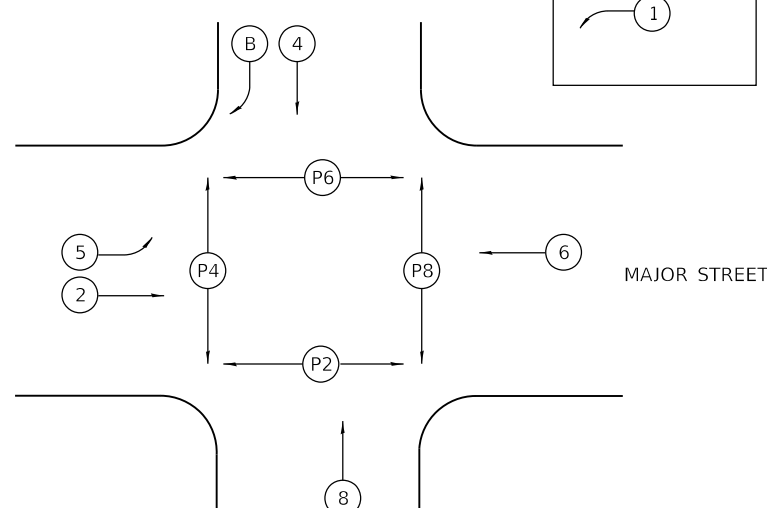
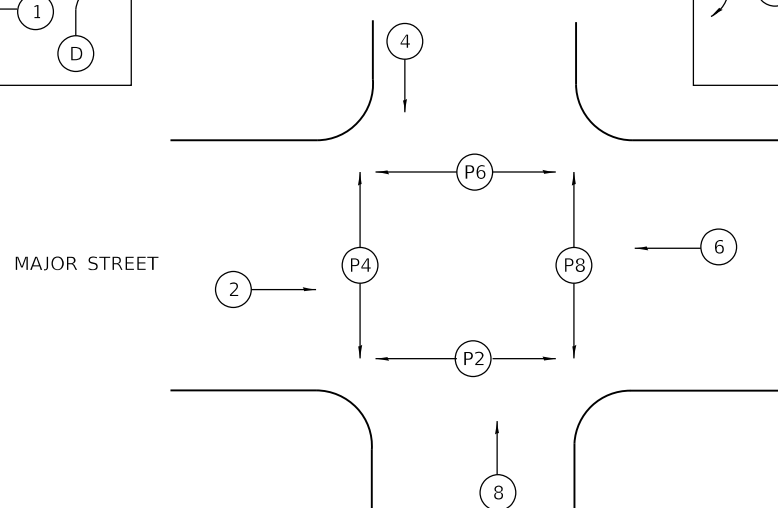
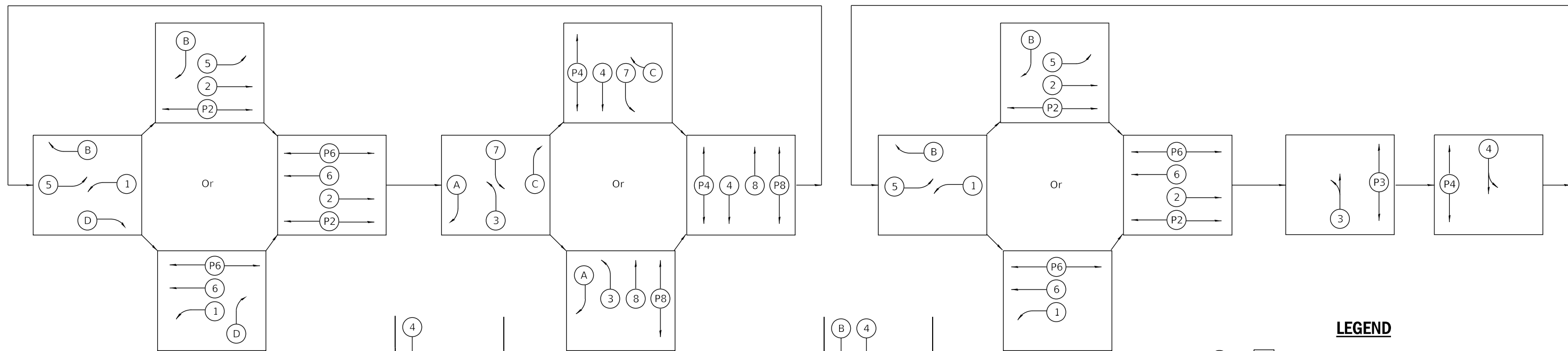
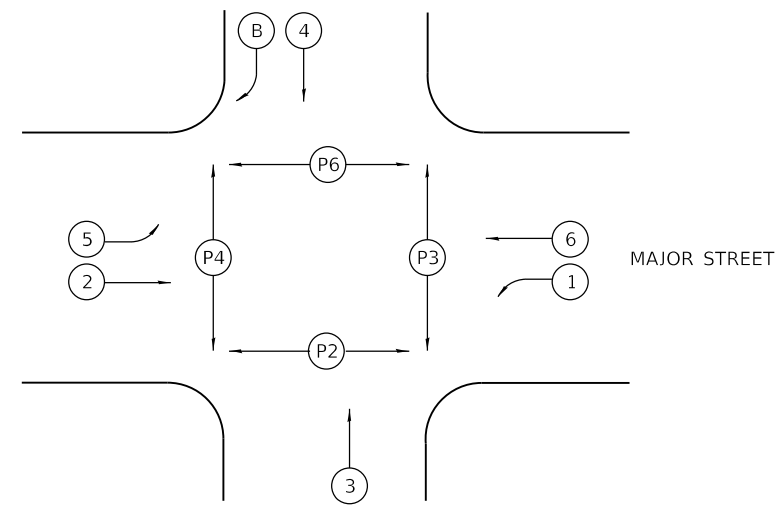
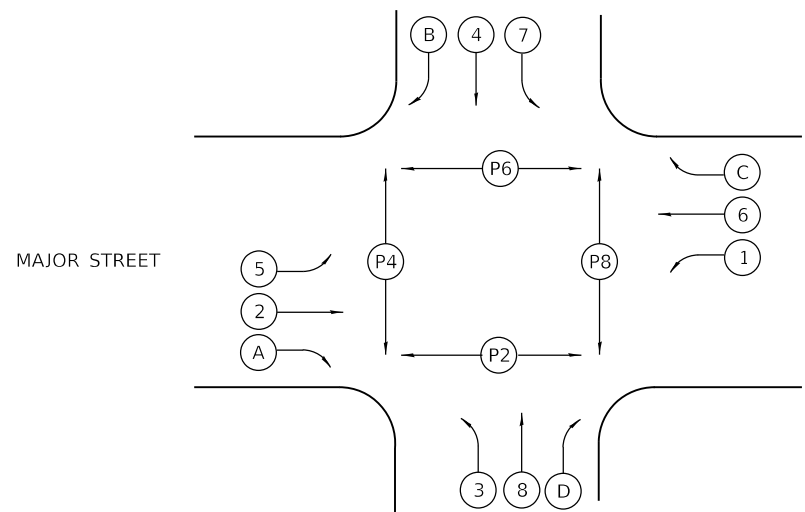

LEGEND

(X), [X] Vehicular phase no. x
 (PX) Pedestrian phase no. x
 (A), (B), (C), (D) Right turn overlaps where:
 (A) = (2) + (3)
 (B) = (4) + (5)
 (C) = (6) + (7)
 (D) = (8) + (1)

NEMA National Electrical Manufacturers Association

Illinois Department of Transportation

PASSED January 1, 2009
 ENGINEER OF OPERATIONS

APPROVED January 1, 2009
 ENGINEER OF DESIGN AND ENVIRONMENT

ISSUED 1-1-97

PHASE DESIGNATION DIAGRAMS AND CORRESPONDING PHASE SEQUENCES

STANDARD PHASE DESIGNATION DIAGRAMS AND PHASE SEQUENCES
 (Sheet 2 of 2)
STANDARD 857001-01

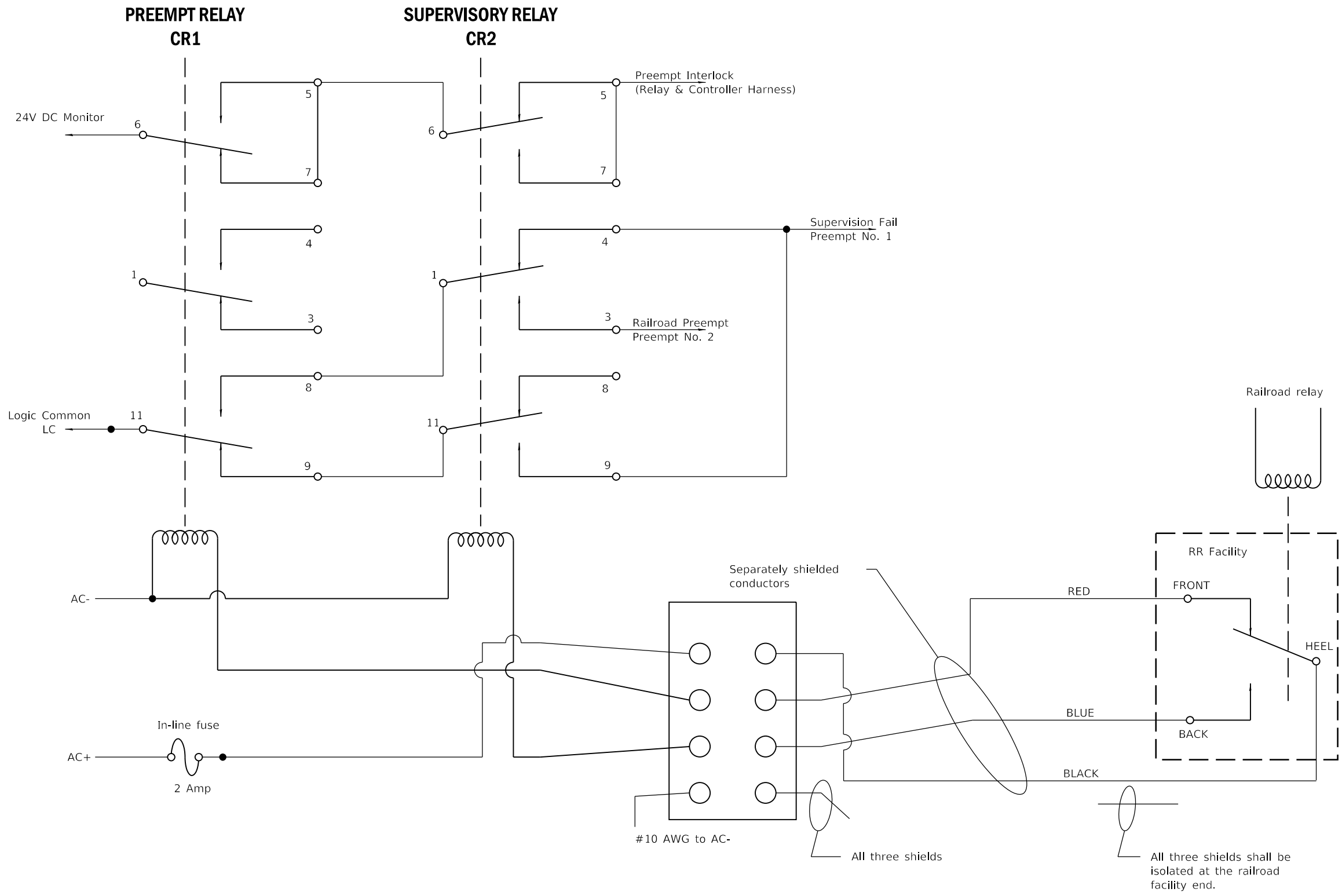

RELAYS IN NON-PREEMPT STATE - RAILROAD AND PREEMPT RELAYS ENERGIZED

GENERAL NOTES

CR1 and CR2 are 120VAC 3PDT Relays.

Supervision Fail is Preempt No. 1, causing traffic signal controller to implement all-red flash following track clearance phase.

Railroad Preempt is Preempt No. 2, causing traffic signal controller to implement railroad preemption routine following 1 second delay.

Preempt No. 1 and Preempt No. 2 shall have priority over all other preempts. The railroad preemption routine shall abbreviate each and all active pedestrian phases by immediately entering into flashing DON'T WALK and timing concurrently with the associated vehicle yellow change interval.

DATE	REVISIONS
1-1-09	Omitted note regarding units of length.
1-1-04	New Standard.

SUPERVISED RAILROAD INTERCONNECT CIRCUIT

STANDARD 857006-01

Illinois Department of Transportation

PASSED January 1, 2009
 ENGINEER OF OPERATIONS
 APPROVED January 1, 2009
 ENGINEER OF DESIGN AND ENVIRONMENT

ISSUED 1-1-04

UPS CABINET

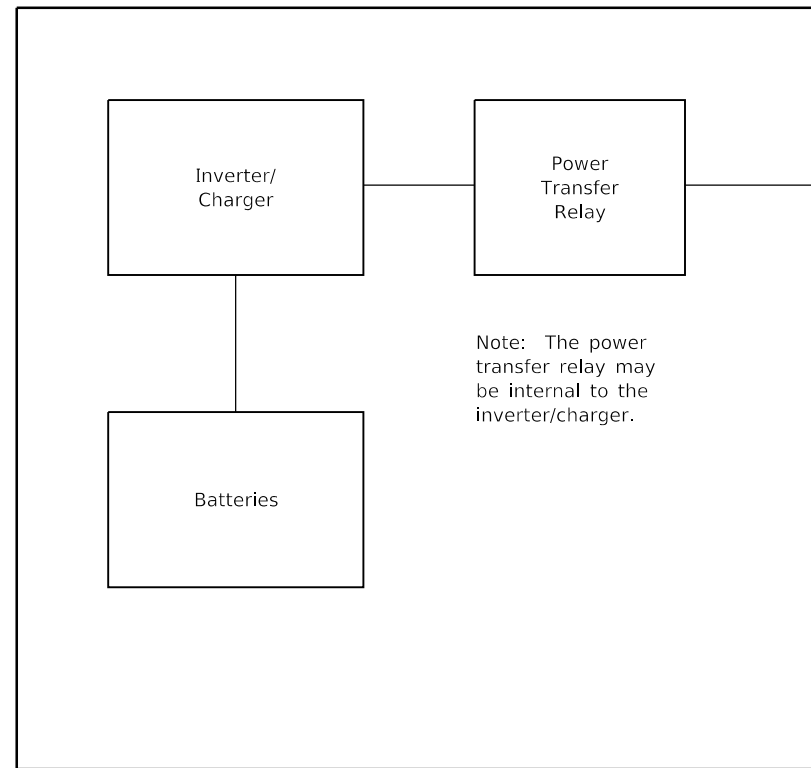

TRAFFIC SIGNAL (NEMA) CABINET

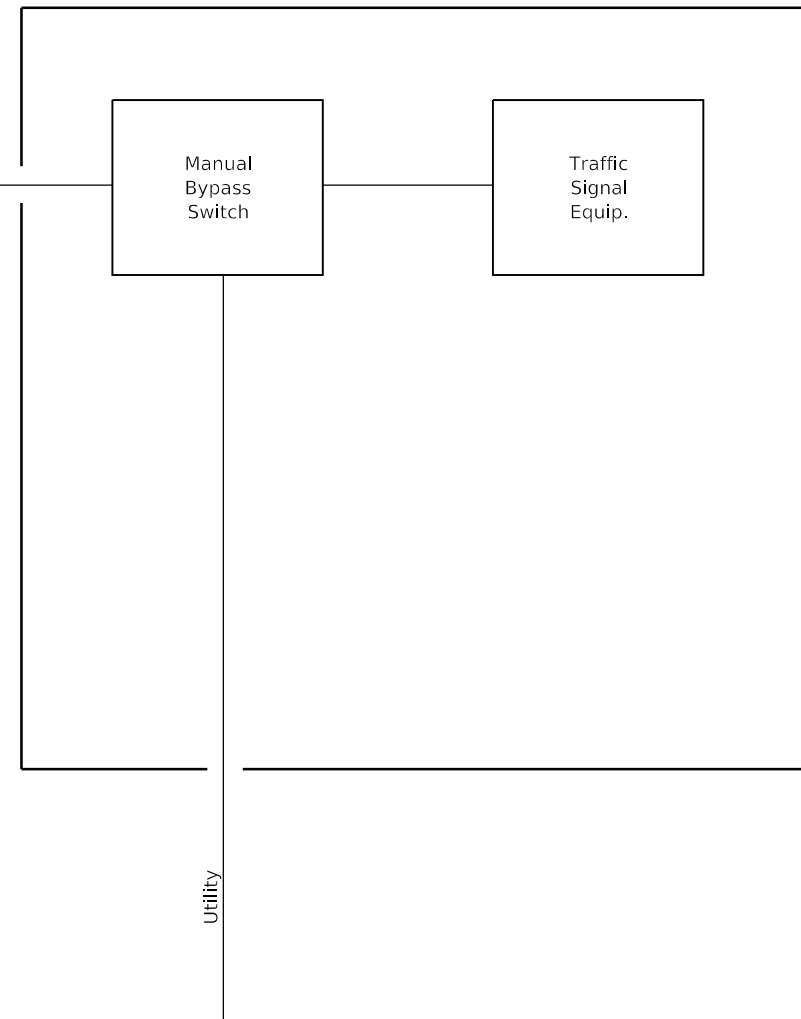

SINGLE LINE BLOCK DIAGRAM

Illinois Department of Transportation

PASSED January 1, 2009

ENGINEER OF OPERATIONS *[Signature]*

APPROVED January 1, 2009

ENGINEER OF DESIGN AND ENVIRONMENT *[Signature]*

ISSUED 4-1-06

DATE	REVISIONS
1-1-09	Omitted note regarding units of length.
4-1-06	New Standard

**UNINTERRUPTABLE
POWER SUPPLY (UPS)**

STANDARD 862001-01

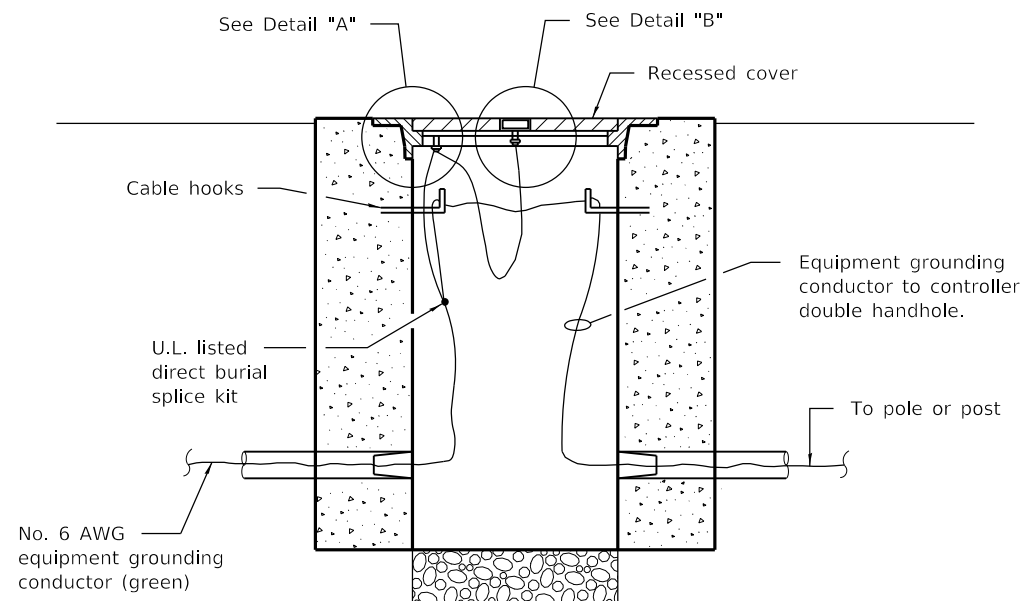

BONDING A HANDHOLE COVER & FRAME

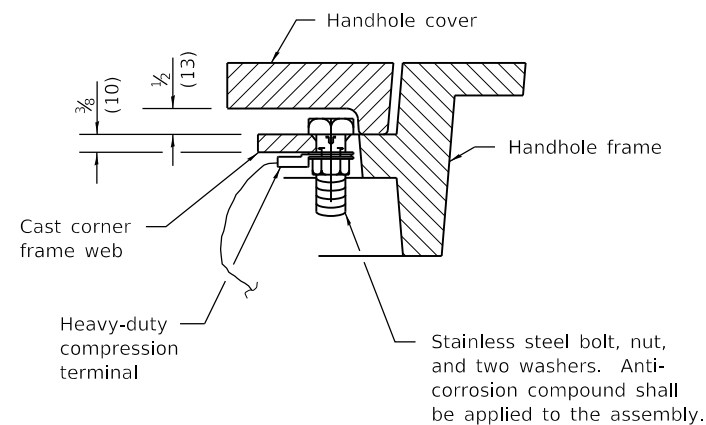

DETAIL "A"

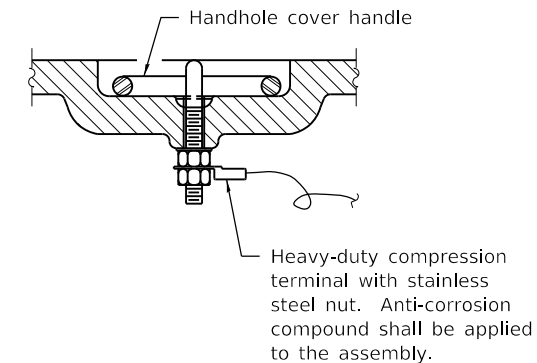

DETAIL "B"

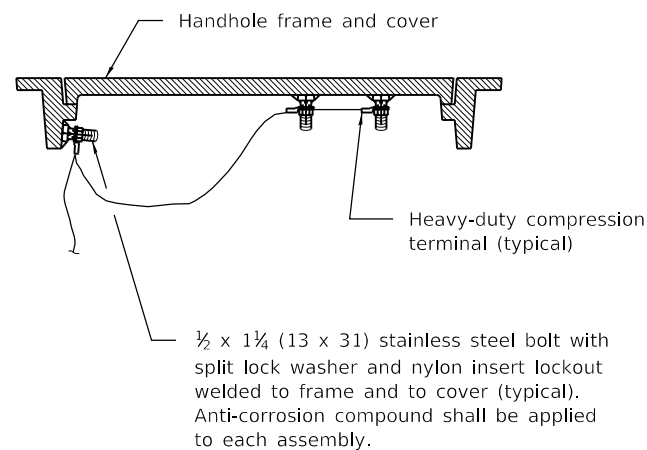

BONDING AN EXISTING HANDHOLE COVER & FRAME

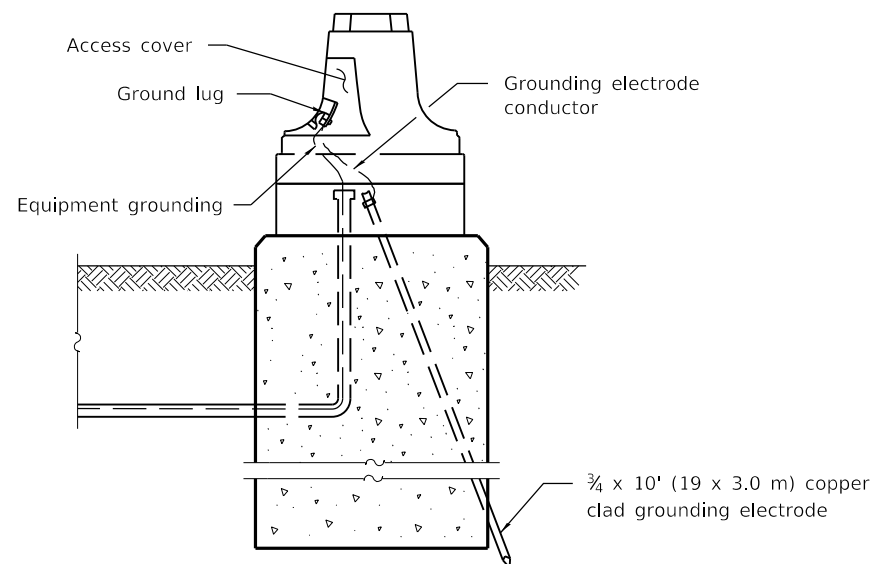

GROUNDING A MAST ARM POLE/POST



HEAVY-DUTY COMPRESSION TERMINAL

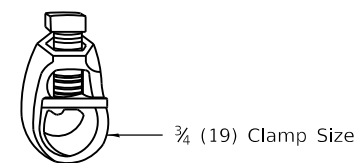

HEAVY-DUTY GROUND ROD CLAMP

All dimensions are in inches (millimeters) unless otherwise shown.

Illinois Department of Transportation

PASSED January 1, 2009
[Signature]
 ENGINEER OF OPERATIONS

APPROVED January 1, 2009
[Signature]
 ENGINEER OF DESIGN AND ENVIRONMENT

ISSUED 4-1-06

DATE	REVISIONS
1-1-09	Switched units to English (metric).
1-1-07	Revised terminology.

**TRAFFIC SIGNAL
GROUNDING & BONDING**

STANDARD 873001-02

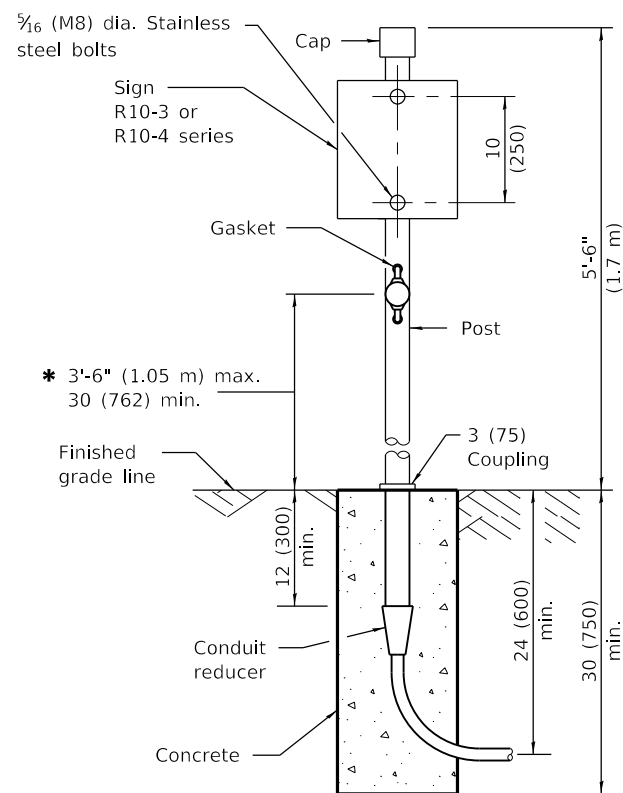

PEDESTRIAN ONE PUSH BUTTON POST

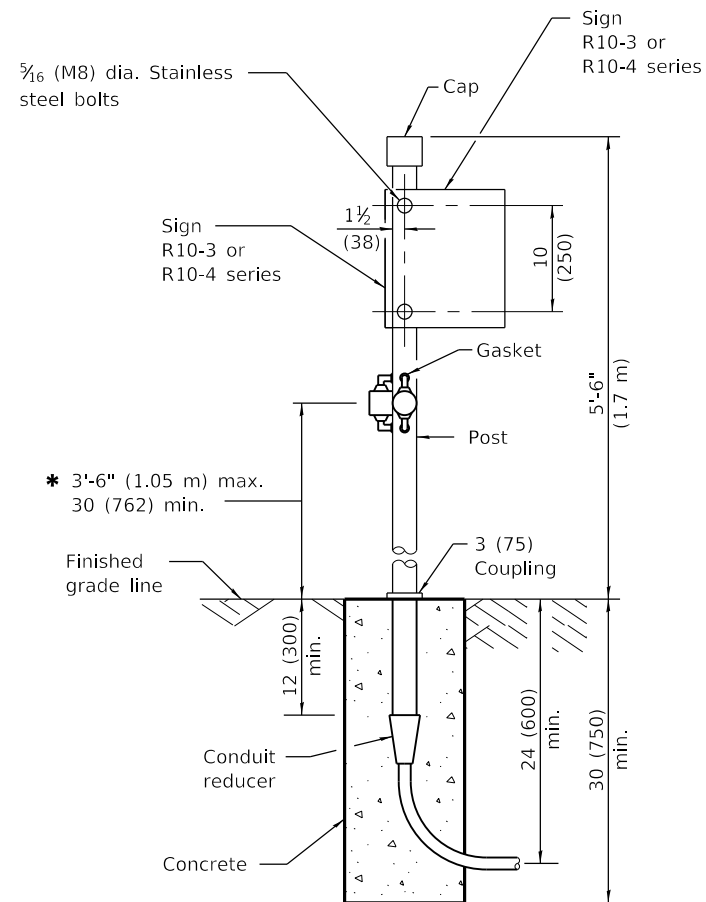

PEDESTRIAN TWO PUSH BUTTON POST

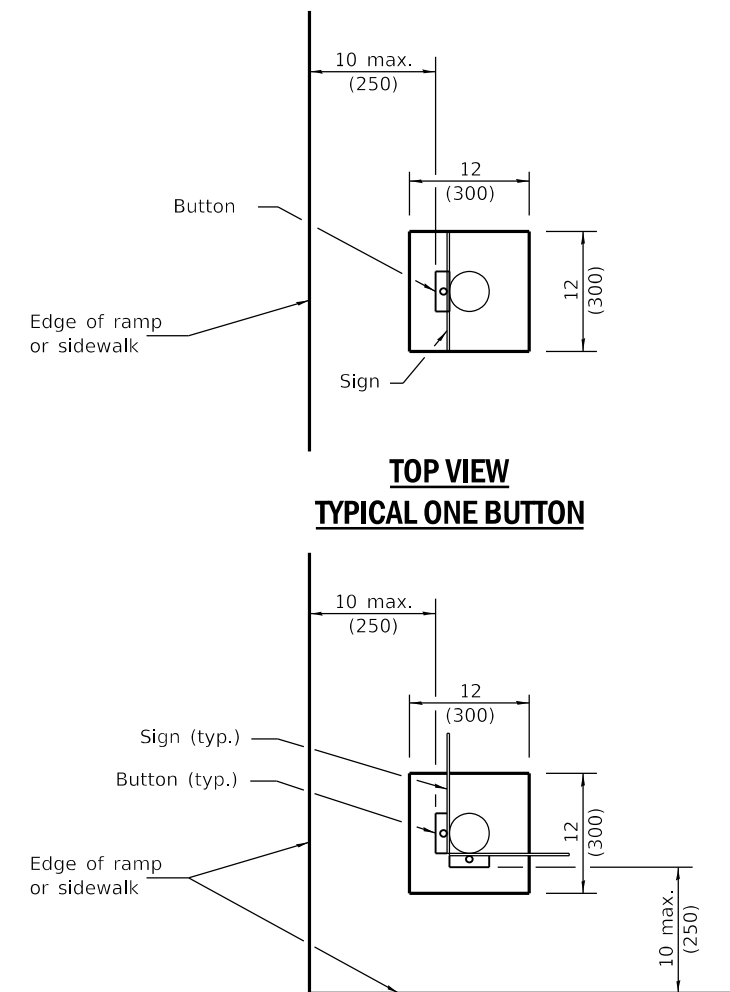

**TOP VIEW
TYPICAL ONE BUTTON**

**TOP VIEW
TYPICAL TWO BUTTONS**

* 36 (914) preferred

All dimensions are in inches (millimeters) unless otherwise shown.

Illinois Department of Transportation

PASSED April 1, 2016

Amy Allen
ENGINEER OF OPERATIONS

APPROVED April 1, 2016

[Signature]
ENGINEER OF DESIGN AND ENVIRONMENT

ISSUED 1-1-07

DATE	REVISIONS
4-1-16	Revised sign numbers for consistency with current MUTCD.
1-1-14	Revised and added dimensions for PROWAG reach range requirements.

**PEDESTRIAN PUSH
BUTTON POST**

STANDARD 876001-04

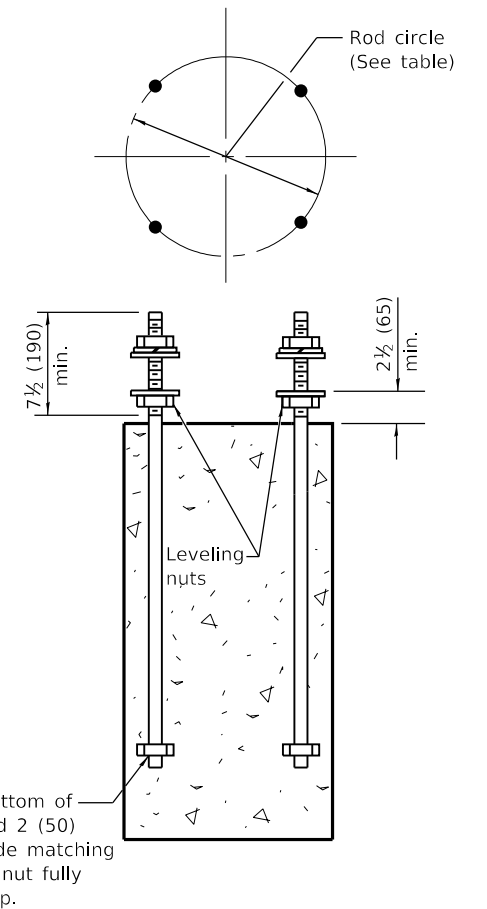
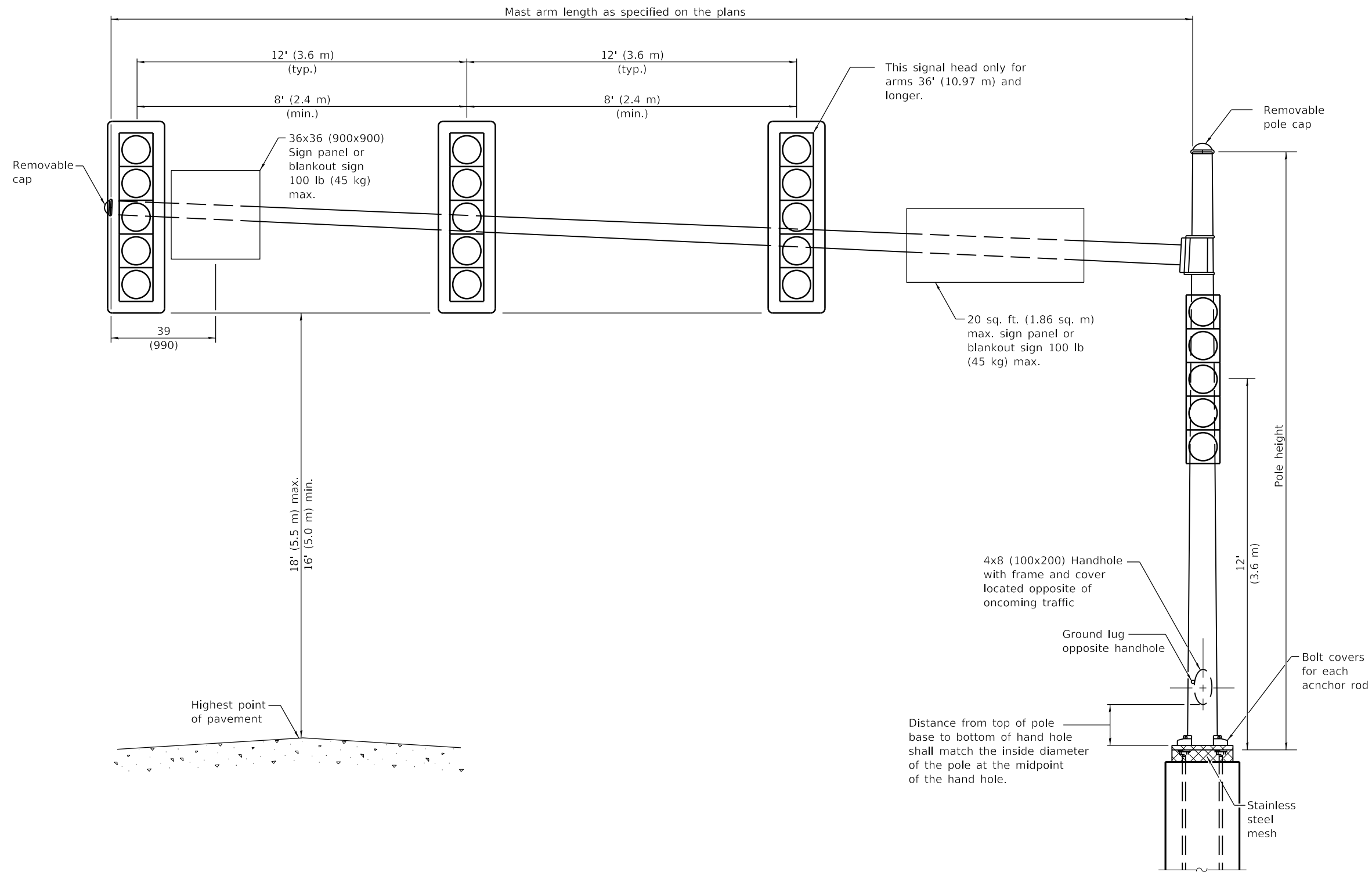

ANCHOR ROD DETAIL

GENERAL NOTES

Signal heads, sign panels, and other attachments are shown for minimum design loading purposes only. Each signal head shall weigh 80 lb (36 kg) and have a projected area of 14.7 sq. ft. (1.37 sq. m).

See Standard 720016 for location of sign panel or blankout sign closest to pole.

All dimensions are in inches (millimeters) unless otherwise shown.

MAST ARM LENGTH	ANCHOR ROD CIRCLE	ANCHOR ROD SIZE
16' thru 40' (4.87 m thru 12.20 m)	18 (450)	1 3/4 x 7' (44 x 2.10 m)
42' thru 55' (12.80 m thru 16.80 m)	21 (535)	1 3/4 x 7' (44 x 2.10 m)

DATE	REVISIONS
1-1-20	Revised mast arm length.
1-1-18	Revised table for LRFD reqs. Revised GEN. NOTES for sign location. Replaced rod hooks with nuts.

STEEL MAST ARM ASSEMBLY AND POLE 16' THROUGH 55'

STANDARD 877001-08

Illinois Department of Transportation

PASSED January 1, 2020
Amy Ellis
 ENGINEER OF OPERATIONS

APPROVED January 1, 2020
S. E. EG
 ENGINEER OF DESIGN AND ENVIRONMENT

ISSUED 1-1-02

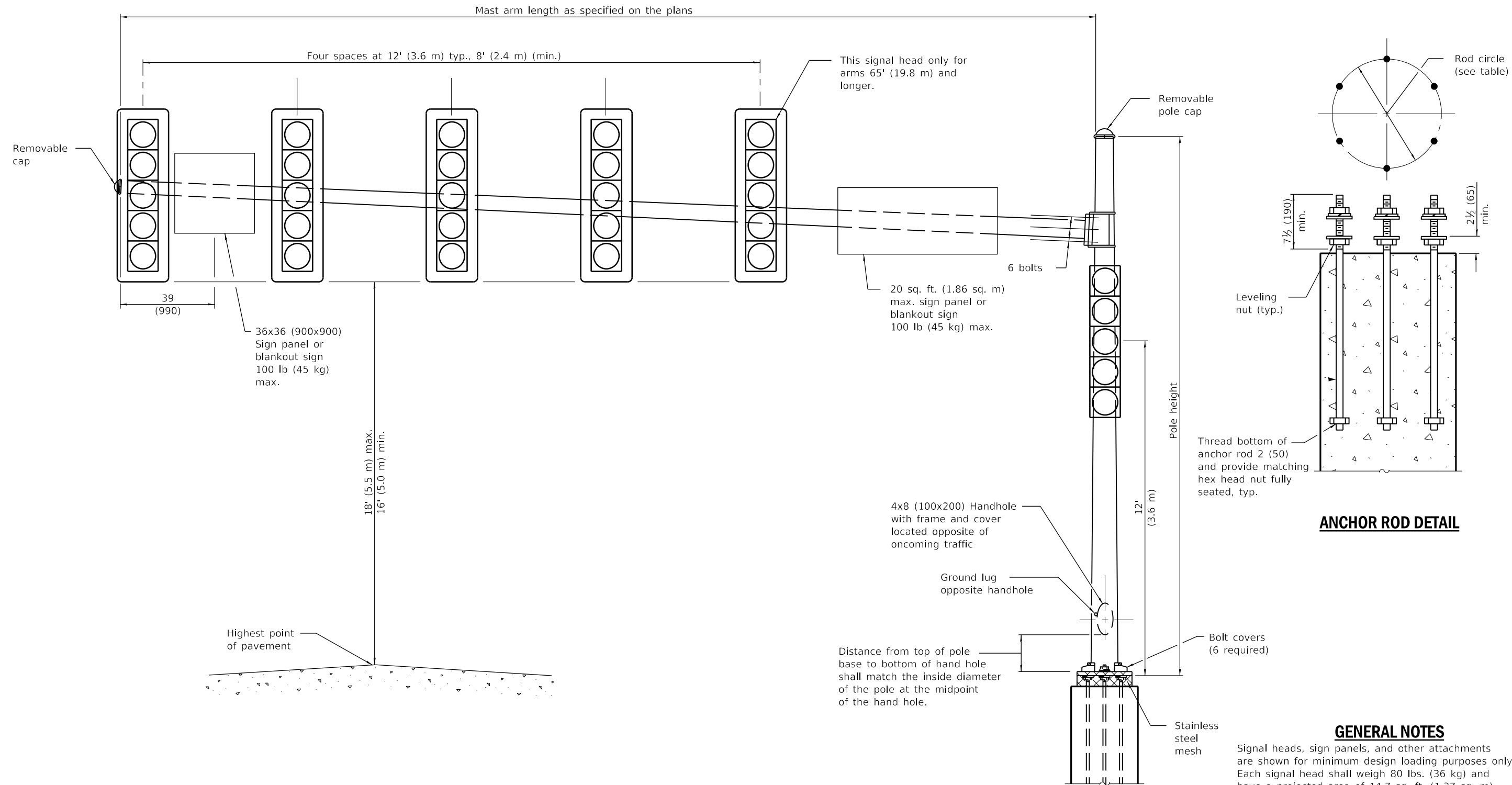

ANCHOR ROD DETAIL

GENERAL NOTES

Signal heads, sign panels, and other attachments are shown for minimum design loading purposes only. Each signal head shall weigh 80 lbs. (36 kg) and have a projected area of 14.7 sq. ft. (1.37 sq. m).

See Standard 720016 for location of sign panel or blankout sign closest to pole.

All dimensions are in inches (millimeters) unless otherwise shown.

MAST ARM LENGTH	ANCHOR ROD CIRCLE	ANCHOR ROD SIZE
56' thru 64' (17.07 m thru 19.51 m)	24 (610)	1 3/4 x 7' (44 x 2.10 m)
65' thru 75' (19.81 m thru 22.86 m)	27 (685)	2 x 7'-6" (51 x 2.29 m)

DATE	REVISIONS
1-1-18	Rev. hand hole loc. Rev. Gen. Notes for sign loc.
	Replaced rod hooks with nuts.
4-1-16	Changed sign panel to 36x36 and 100 lb max.

STEEL MAST ARM ASSEMBLY AND POLE 56' THROUGH 75'

STANDARD 877002-04

Illinois Department of Transportation

PASSED January 1, 2018
Amy Allen
 ENGINEER OF OPERATIONS

APPROVED January 1, 2018
Maureen M. Beck
 ENGINEER OF DESIGN AND ENVIRONMENT

ISSUED 1-1-08

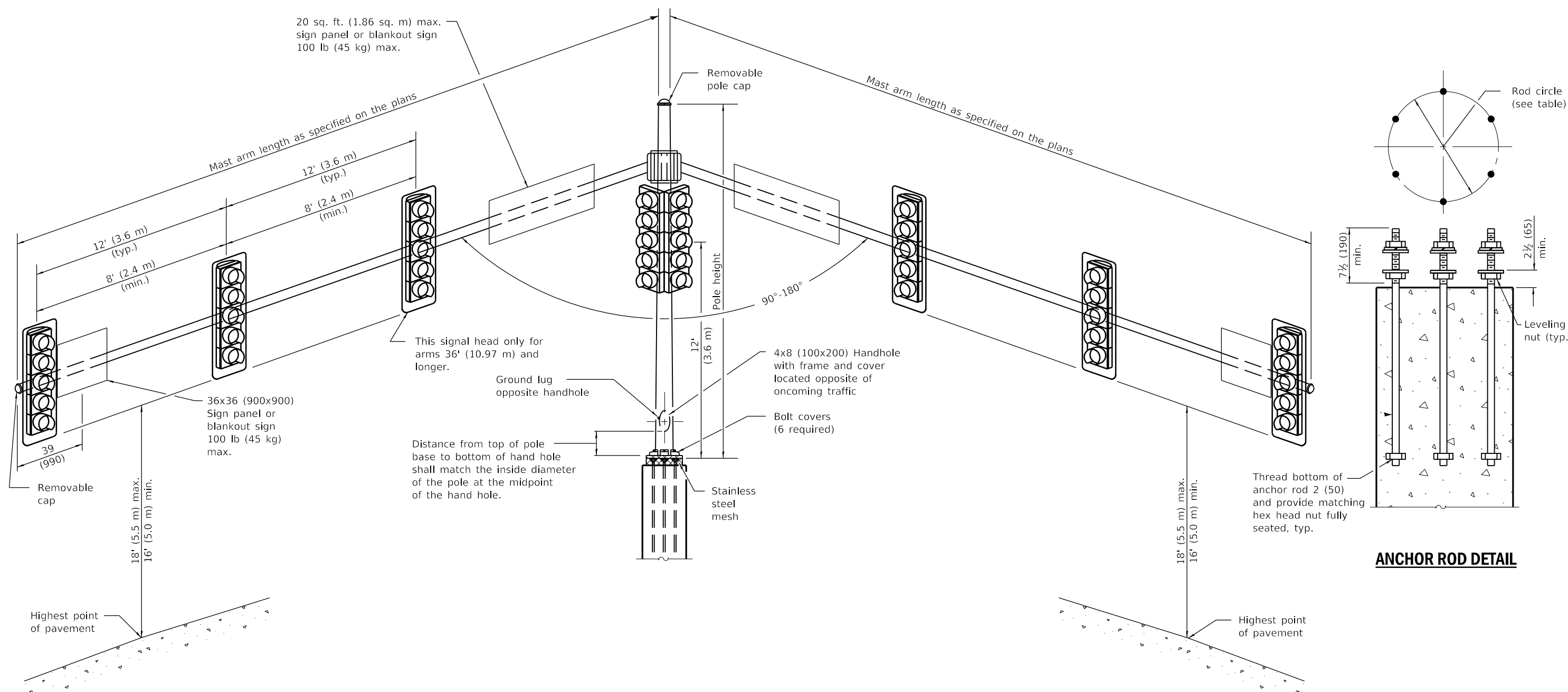

ANCHOR ROD DETAIL

GENERAL NOTES

Signal heads, sign panels, and other attachments are shown for minimum design loading purposes only. Each signal head shall weigh 80 lb (36 kg) and have a projected area of 14.7 sq. ft. (1.37 sq. m).

See Standard 720016 for location of sign panels or blankout signs closest to pole.

All dimensions are in inches (millimeters) unless otherwise shown.

MAST ARM LENGTH	ANCHOR ROD CIRCLE	ANCHOR ROD SIZE
16' thru 30' (4.87 m thru 9.14 m)	18 (450)	1 3/4 x 7' (44 x 2.10 m)
32' thru 50' (9.75 m thru 15.24 m)	21 (535)	2 x 7'-6" (51 x 2.29 m)

DATE	REVISIONS
1-1-18	Revised for RLFD reqs. Revised GEN. NOTES for sign locaton.
	Revised ANCHOR ROD DETAIL.
4-1-16	Changed sign panel to 36x36.
	Added max weight of 100 lb.
	Modified dim. to outer signal.

STEEL MAST ARM ASSEMBLY AND POLE WITH DUAL MAST ARMS

STANDARD 877006-06

Illinois Department of Transportation

PASSED January 1, 2018
Amy Allen
ENGINEER OF OPERATIONS

APPROVED January 1, 2018
Maureen M. Beck
ENGINEER OF DESIGN AND ENVIRONMENT

ISSUED 1-1-02

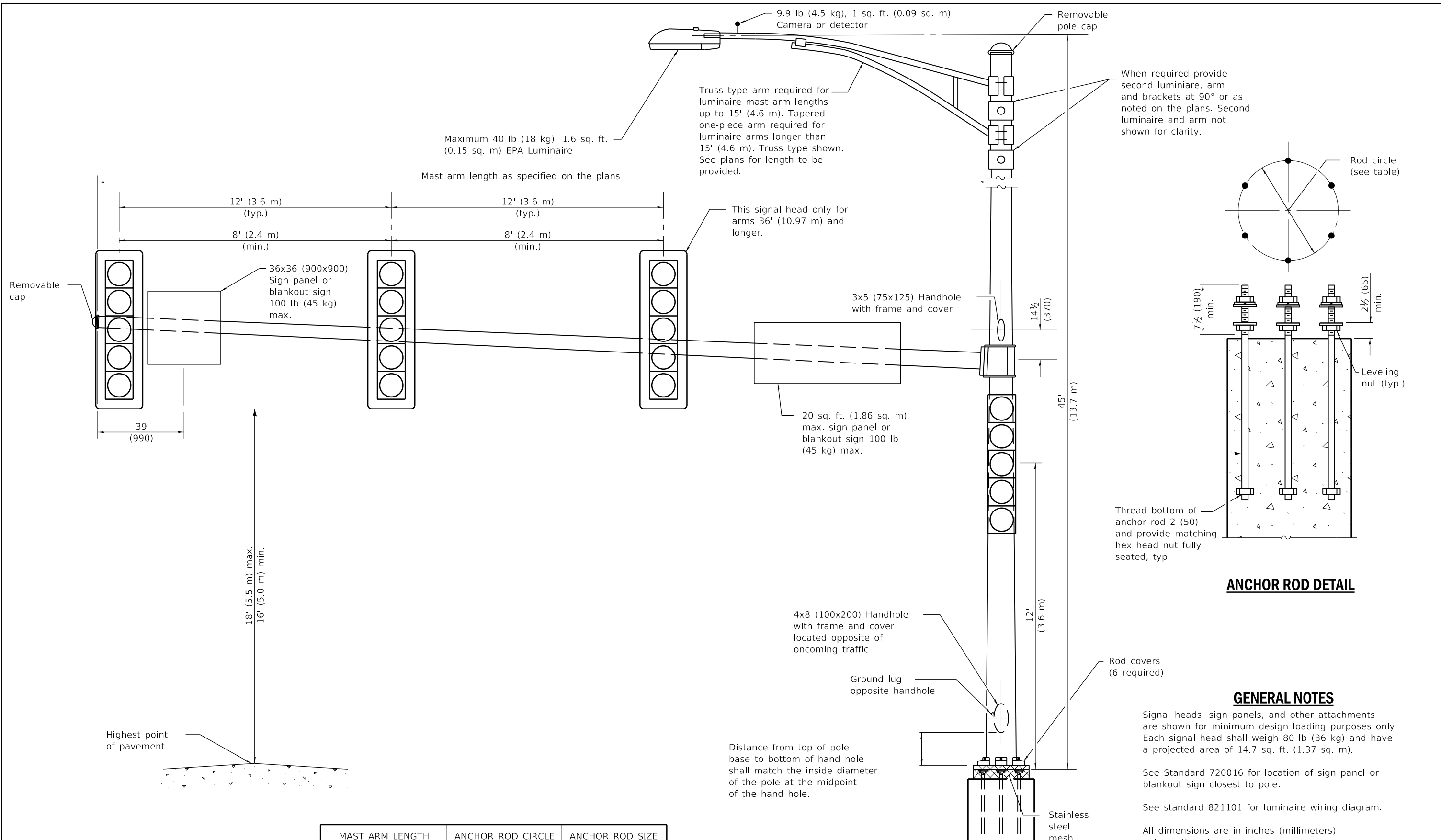

When required provide second luminaire, arm and brackets at 90° or as noted on the plans. Second luminaire and arm not shown for clarity.

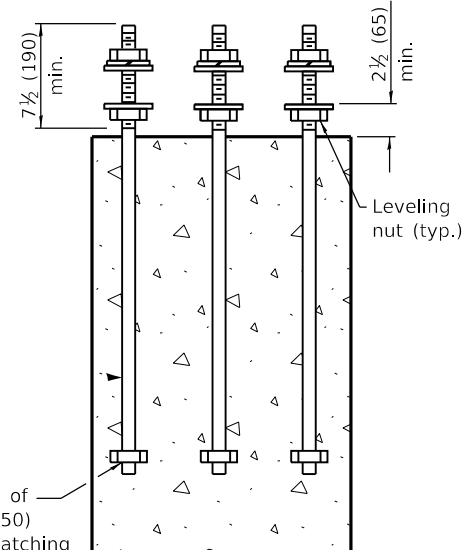
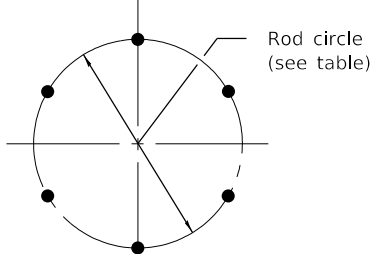

ANCHOR ROD DETAIL

GENERAL NOTES

Signal heads, sign panels, and other attachments are shown for minimum design loading purposes only. Each signal head shall weigh 80 lb (36 kg) and have a projected area of 14.7 sq. ft. (1.37 sq. m).

See Standard 720016 for location of sign panel or blankout sign closest to pole.

See standard 821101 for luminaire wiring diagram.

All dimensions are in inches (millimeters) unless otherwise shown.

MAST ARM LENGTH	ANCHOR ROD CIRCLE	ANCHOR ROD SIZE
16' thru 35' (4.87 m thru 10.67 m)	18 (450)	1 3/4 x 7' (44 x 2.10 m)
36' thru 55' (10.97 m thru 16.80 m)	21 (535)	1 3/4 x 7' (44 x 2.10 m)

DATE	REVISIONS
1-1-19	Remove tenon top info.
	Rev. luminaire arm info.
	Rev. second luminaire info.
1-1-18	Revised for LRFD reqs. Revised
	GEN. NOTES for sign locaton.
	Revised ANCHOR ROD DETAIL.

STEEL COMB. MAST ARM ASSEMBLY AND POLE 16' THROUGH 55'

STANDARD 877011-10

Illinois Department of Transportation

APPROVED January 1, 2019

 ENGINEER OF OPERATIONS

APPROVED January 1, 2019

 ENGINEER OF DESIGN AND ENVIRONMENT

ISSUED 1-1-02

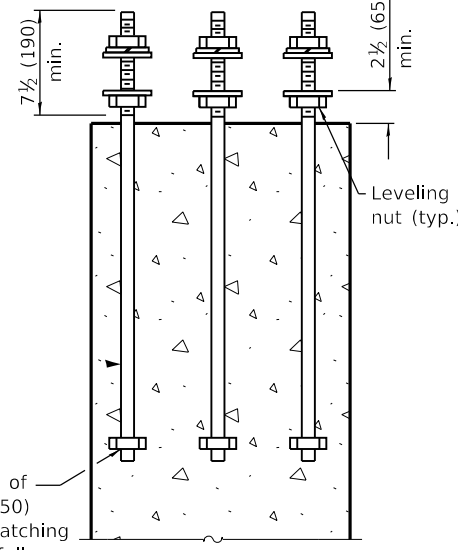
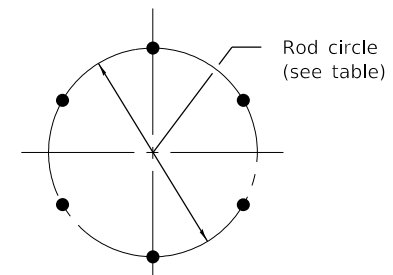
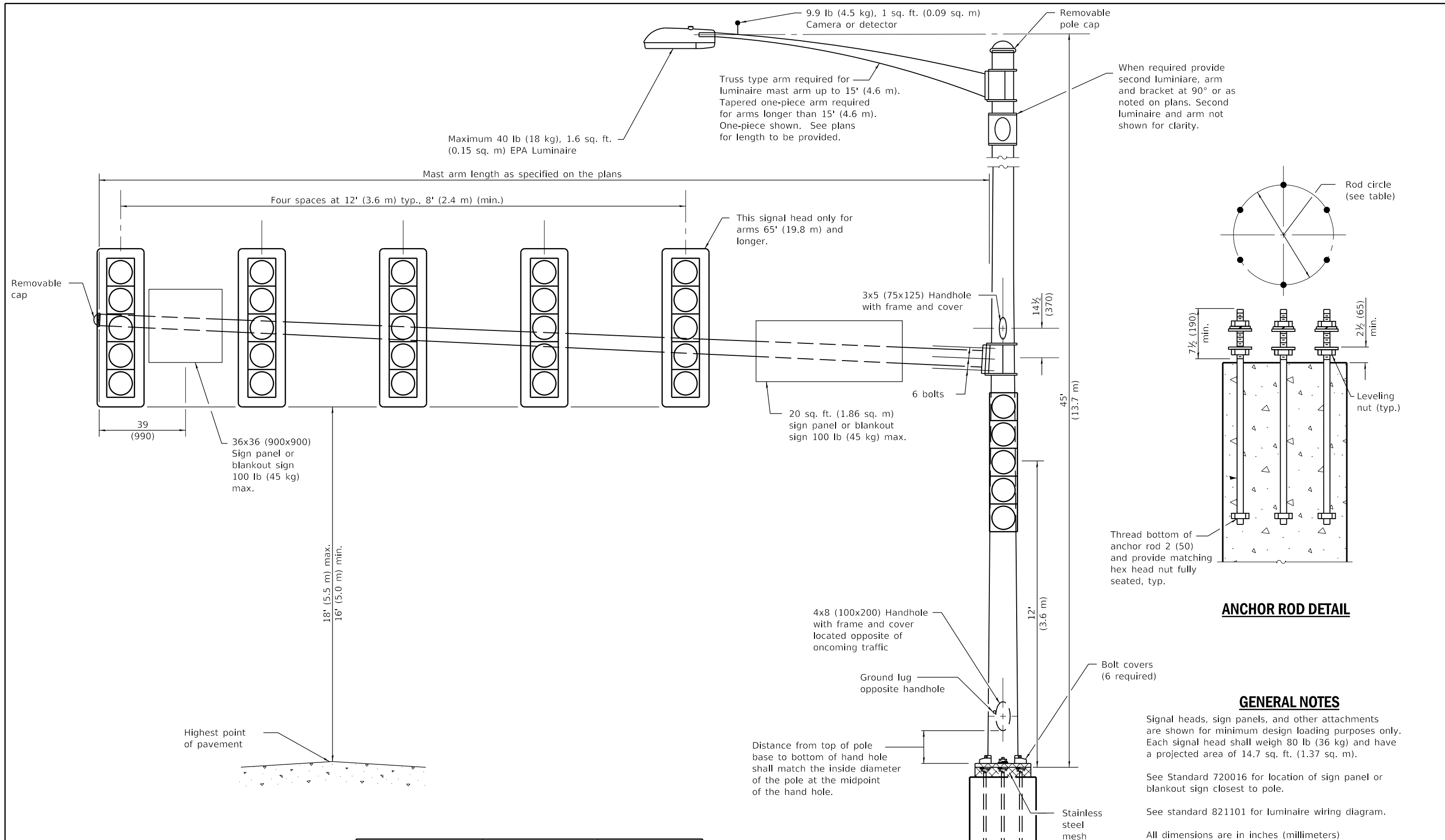

ANCHOR ROD DETAIL

GENERAL NOTES

Signal heads, sign panels, and other attachments are shown for minimum design loading purposes only. Each signal head shall weigh 80 lb (36 kg) and have a projected area of 14.7 sq. ft. (1.37 sq. m).

See Standard 720016 for location of sign panel or blankout sign closest to pole.

See standard 821101 for luminaire wiring diagram.

All dimensions are in inches (millimeters) unless otherwise shown.

MAST ARM LENGTH	ANCHOR ROD CIRCLE	ANCHOR ROD SIZE
56' thru 64' (17.07 m thru 19.51 m)	24 (610)	1 3/4 x 7' (44 x 2.10 m)
65' thru 75' (19.81 m thru 22.86 m)	27 (685)	2 x 7'-6" (51 x 2.29 m)

DATE	REVISIONS
1-1-19	Remove tenon top Info.
	Rev. luminaire arm info.
	Rev. second luminaire info.
1-1-18	Rev. hand hole location. Rev.
	Gen. Notes for sign location.
	Replaced rod hooks with nuts.

STEEL COMB. MAST ARM ASSEMBLY AND POLE 56' THROUGH 75'

STANDARD 877012-07

Illinois Department of Transportation

APPROVED January 1, 2019
Amy Allen
ENGINEER OF OPERATIONS

APPROVED January 1, 2019
Joe E. ...
ENGINEER OF DESIGN AND ENVIRONMENT

ISSUED 1-1-08

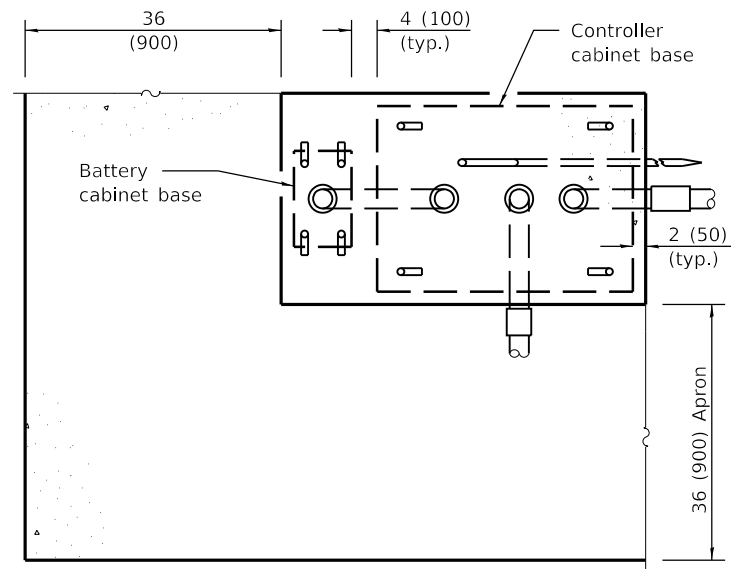

TOP VIEW

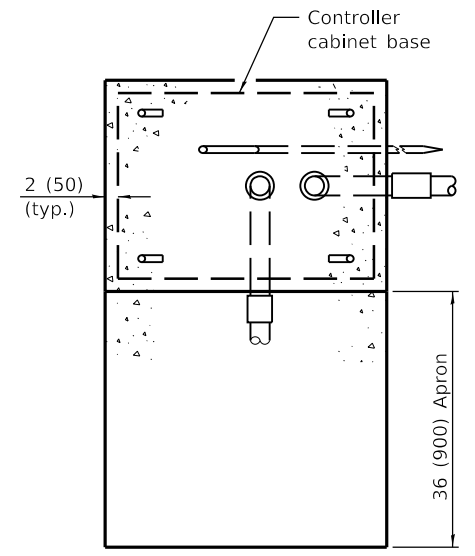

TOP VIEW

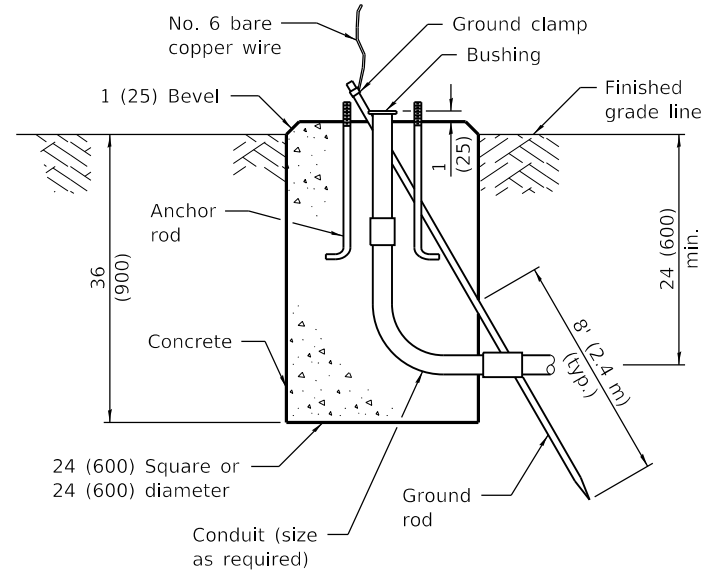

TYPE A

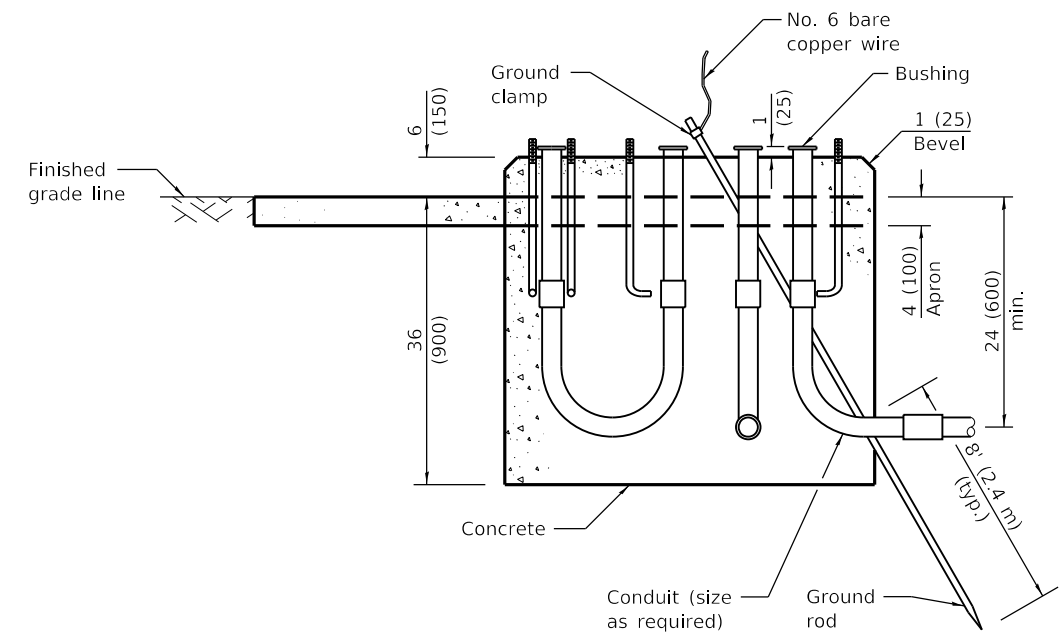

**TYPE C
FOR GROUND MOUNTED
CONTROLLER CABINET
AND UPS BATTERY CABINET**

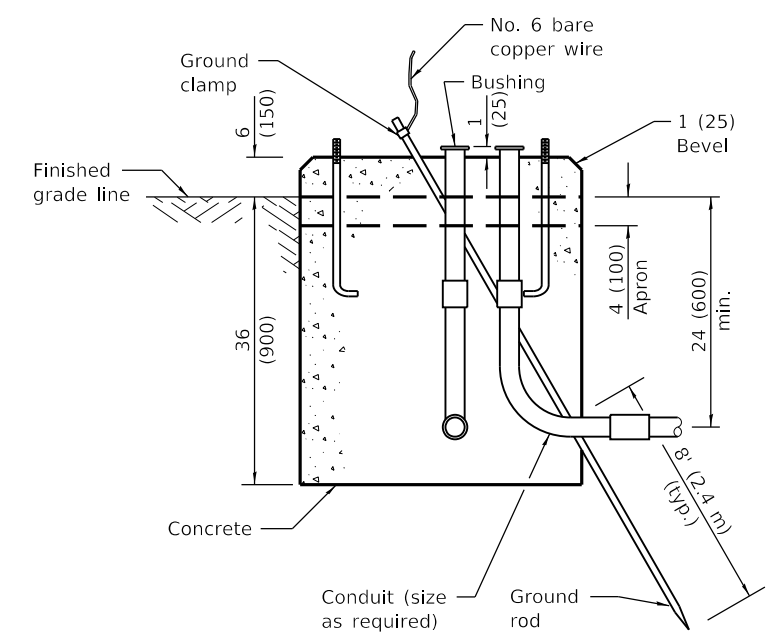

**TYPE D
FOR GROUND MOUNTED
CONTROLLER CABINET**

All dimensions are in inches (millimeters) unless otherwise shown.

Illinois Department of Transportation

PASSED January 1, 2021
Amy Ellis
 ENGINEER OF OPERATIONS

APPROVED January 1, 2021
S. E. EG
 ENGINEER OF DESIGN AND ENVIRONMENT

ISSUED 1-1-02

DATE	REVISIONS
1-1-21	Revised anchor rod end in Type E detail.
1-1-15	Revised TYPE E detail.

**CONCRETE
FOUNDATION DETAILS**

(Sheet 1 of 2)

STANDARD 878001-11

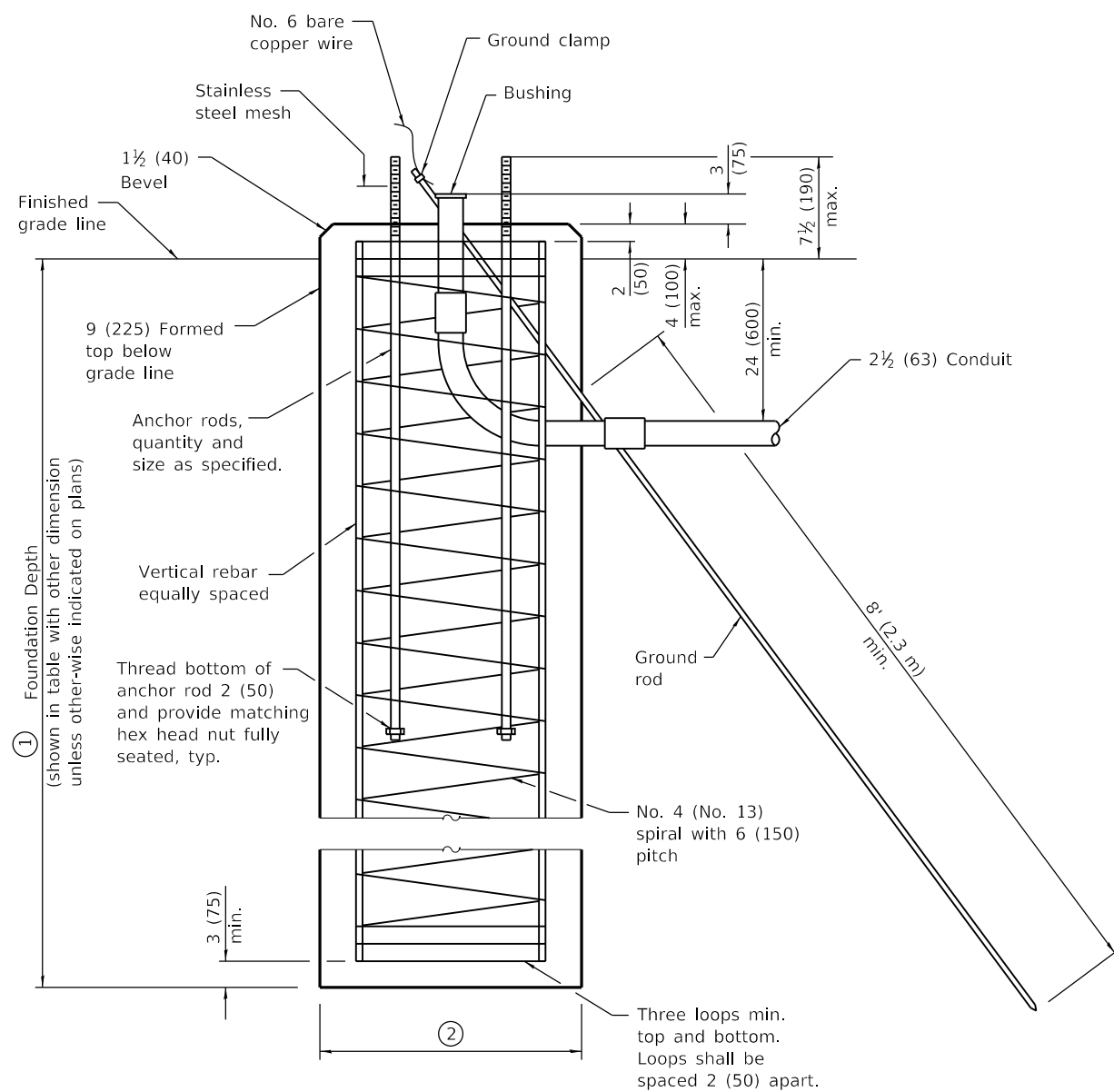
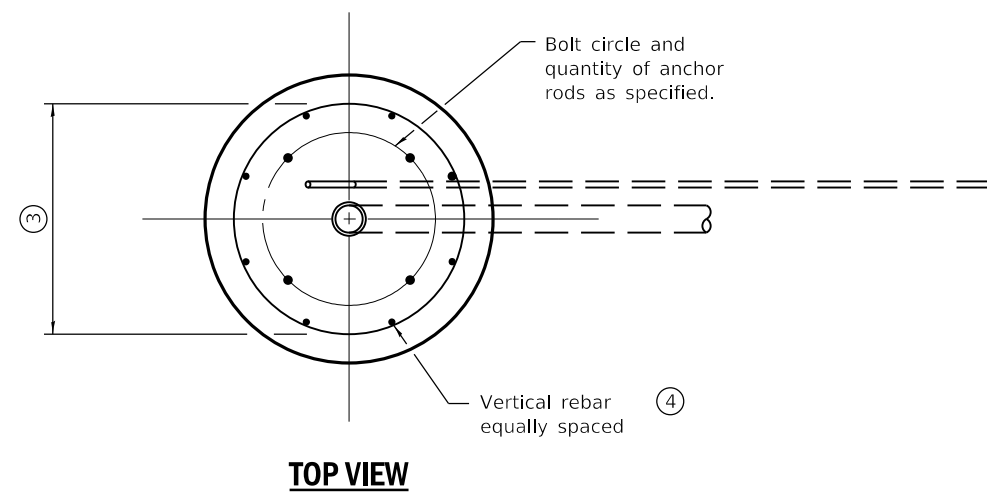

Mast Arm Length	① Foundation Depth *	② Foundation Diameter	③ Spiral Diameter	④ Quantity of Rebars	Size of Rebars
Less than 30' (9.1 m)	10'-0" (3.0 m)	30 (750)	24 (600)	8	6 (19)
Greater than or equal to 30' (9.1 m) and less than 40' (12.2 m)	13'-6" (4.1 m)	30 (750)	24 (600)	8	6 (19)
	11'-0" (3.4 m)	36 (900)	30 (750)	12	7 (22)
Greater than or equal to 40' (12.2 m) and less than 50' (15.2 m)	13'-0" (4.0 m)	36 (900)	30 (750)	12	7 (22)
	15'-0" (4.6 m)	36 (900)	30 (750)	12	7 (22)
Greater than or equal to 50' (15.2 m) and up to 55' (16.8 m)	21'-0" (6.4 m)	42 (1060)	36 (900)	16	8 (25)
Greater than or equal to 55' (16.8 m) and up to 65' (19.8 m)	25'-0" (7.6 m)	42 (1060)	36 (900)	16	8 (25)
Greater than or equal to 65' (19.8 m) and up to 75' (22.9 m)					

* For standard and combination mast arm assemblies. Foundation depths for standard dual mast arms with the longest arm length upto and including 55' (16.8 m) shall be increased by 1' (0.3 m) of that shown in the table, based on the longer of the two arms.

These foundation depths are for sites which have cohesive soils (clayey silt, sandy clay, etc.) along the length of the shaft, with an average Unconfined Compressive Strength (Q_u) > 1.0 tsf (100 kpa). This strength shall be verified by boring data prior to construction or with testing by the Engineer during foundation drilling. The Bureau of Bridges & Structures should be contacted for a revised design if other conditions are encountered.

Illinois Department of Transportation

PASSED January 1, 2021
Amy Ellis
 ENGINEER OF OPERATIONS

APPROVED January 1, 2021
S. E. E. G.
 ENGINEER OF DESIGN AND ENVIRONMENT

ISSUED 1-1-02

TYPE E

**CONCRETE
 FOUNDATION DETAILS**

(Sheet 2 of 2)

STANDARD 878001-11

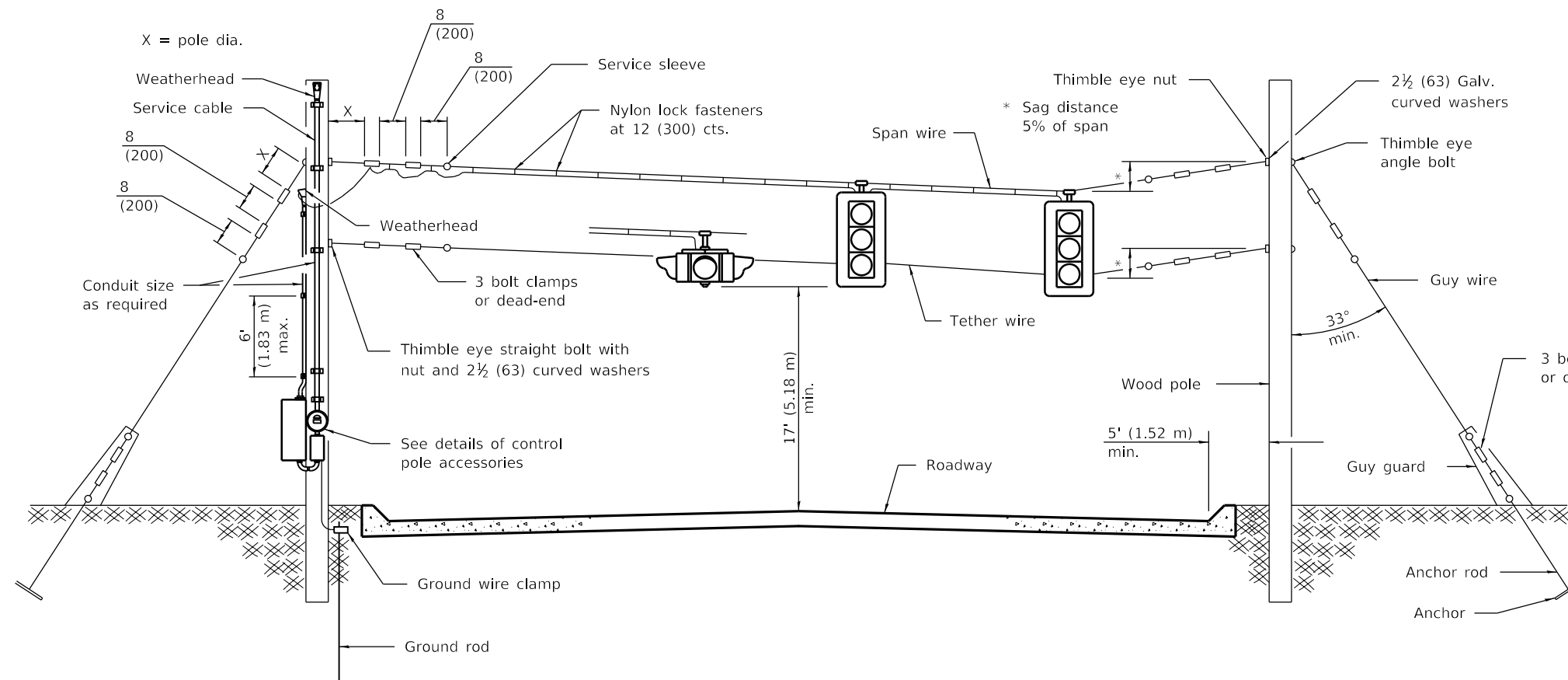

SPAN WIRE MOUNTED SIGNALS AND FLASHING BEACON

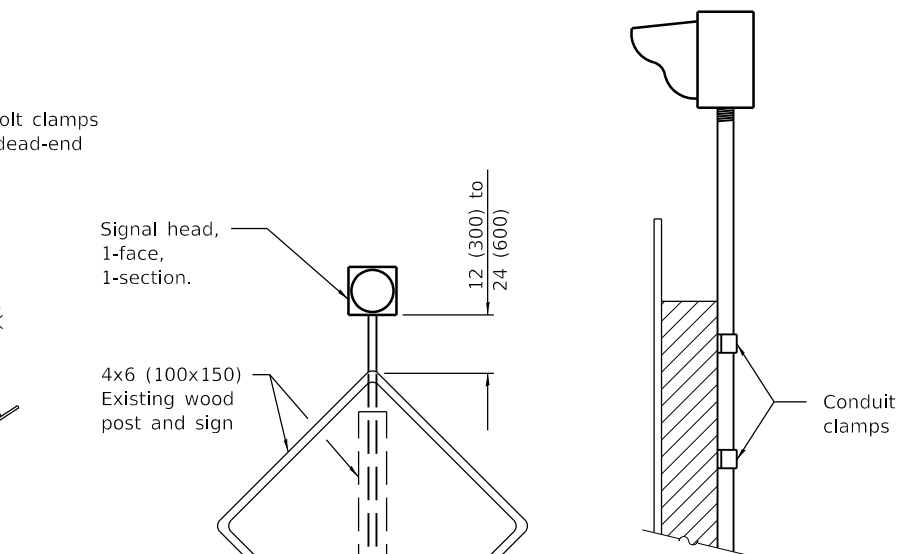

MOUNTING DETAIL

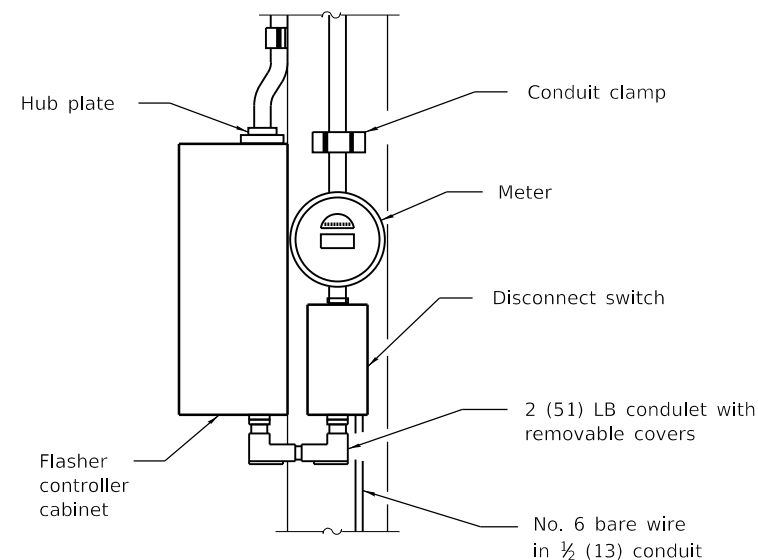

CONTROL POLE DETAIL

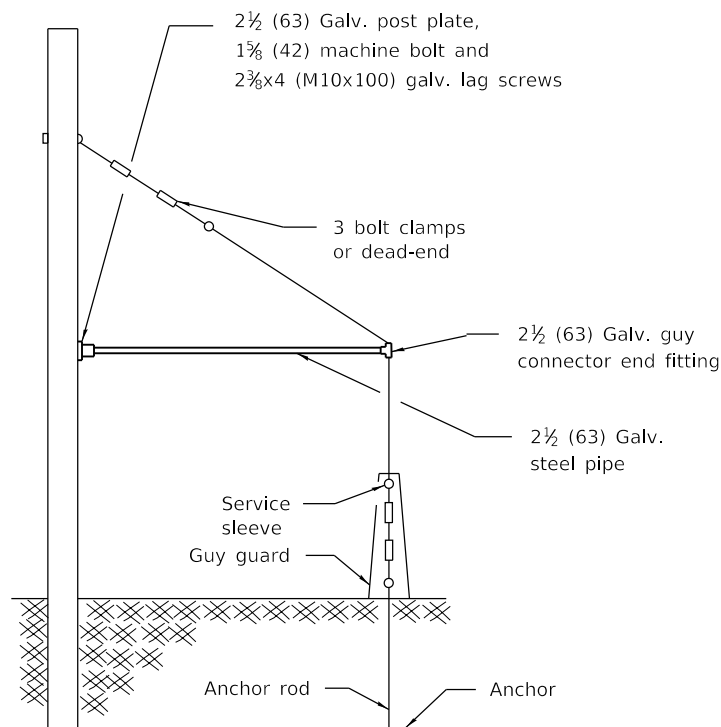

SIDEWALK GUY DETAIL

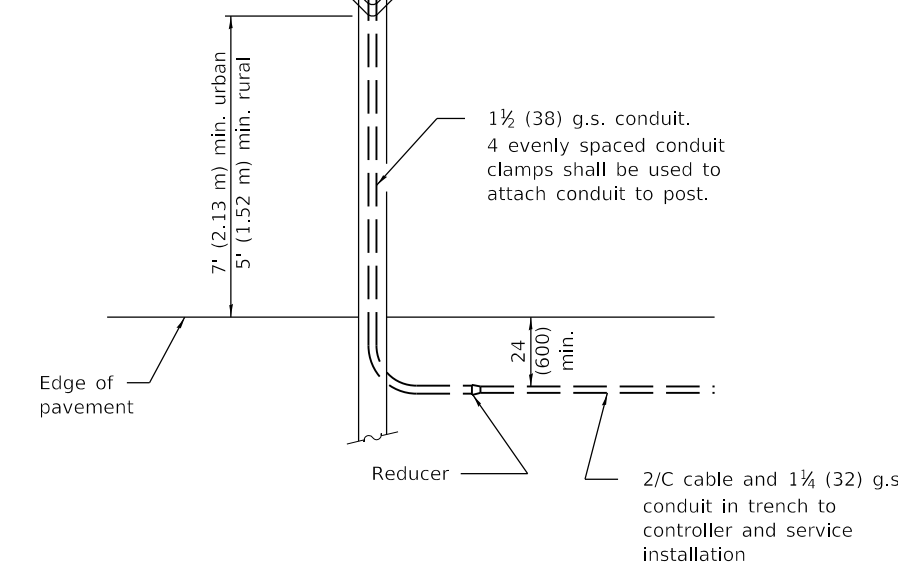

POST MOUNTED FLASHING BEACON

All dimensions are in inches (millimeters) unless otherwise shown.

Illinois Department of Transportation

PASSED January 1, 2009

ENGINEER OF OPERATIONS

APPROVED January 1, 2009

ENGINEER OF DESIGN AND ENVIRONMENT

ISSUED 1-1-02

DATE	REVISIONS
1-1-09	Switched units to English (metric).
1-1-02	Renum. Standard 840001.

SPAN WIRE MOUNTED SIGNALS AND FLASHING BEACON INSTALLATION

STANDARD 880001-01

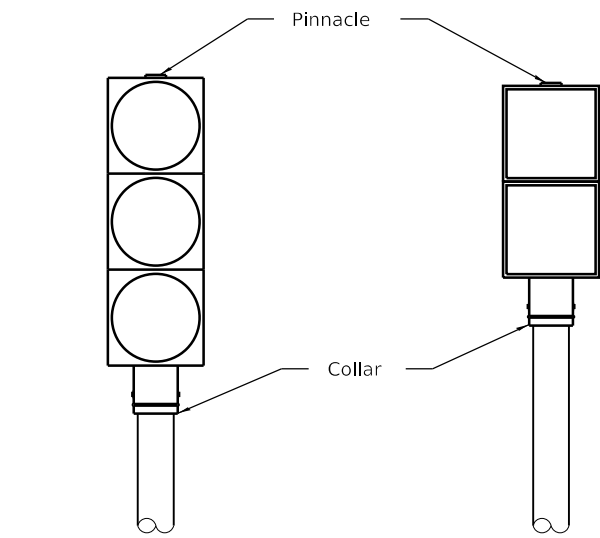

**POST MOUNTED
TRAFFIC SIGNAL HEAD**

ONE WAY

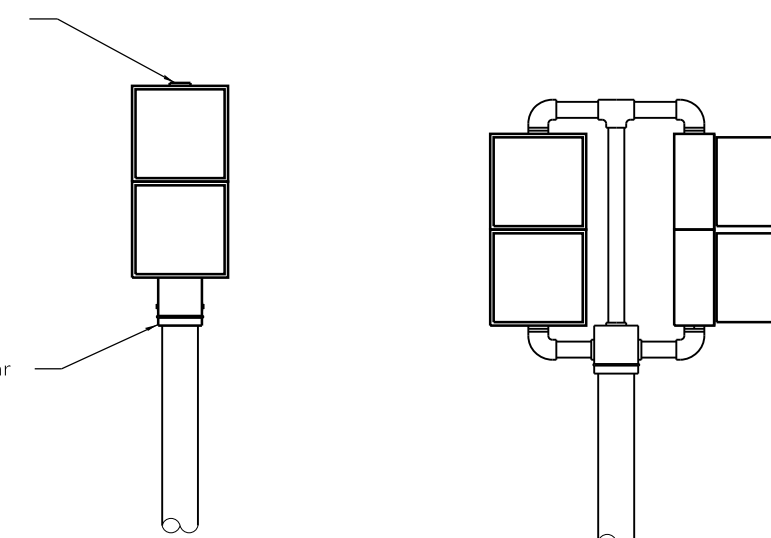

**POST MOUNTED
PEDESTRIAN SIGNAL HEAD**

**POST MOUNTED
PEDESTRIAN SIGNAL HEAD**

TWO WAY

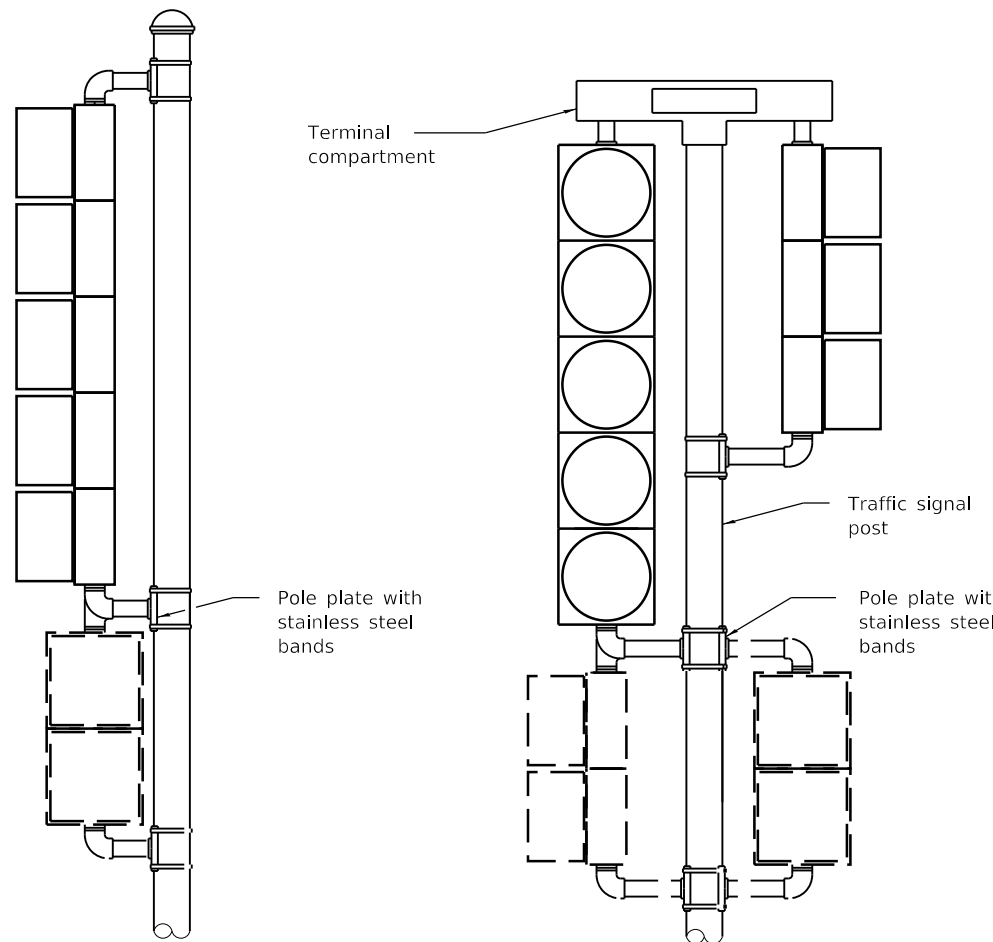

**BRACKET MOUNTED
TRAFFIC SIGNAL HEAD**

ONE WAY

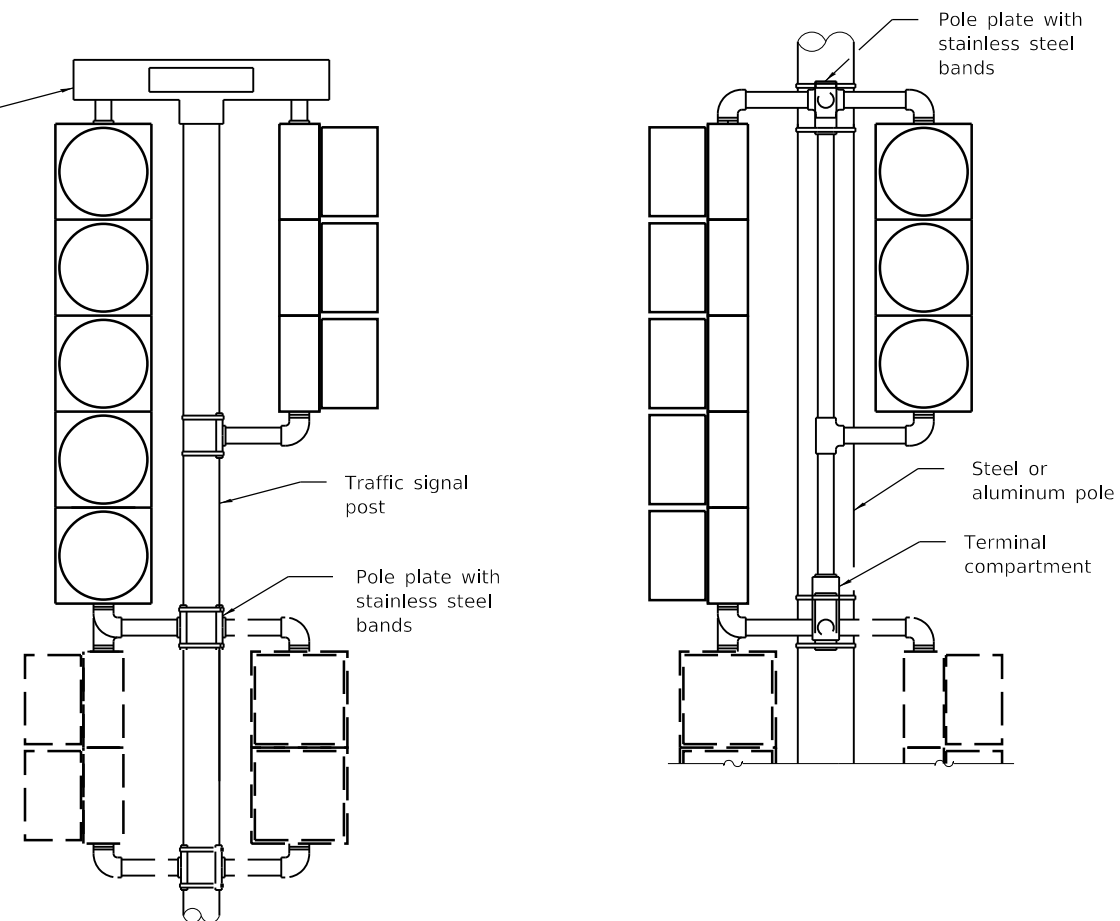

**BRACKET MOUNTED
TRAFFIC SIGNAL HEAD**

TWO WAY

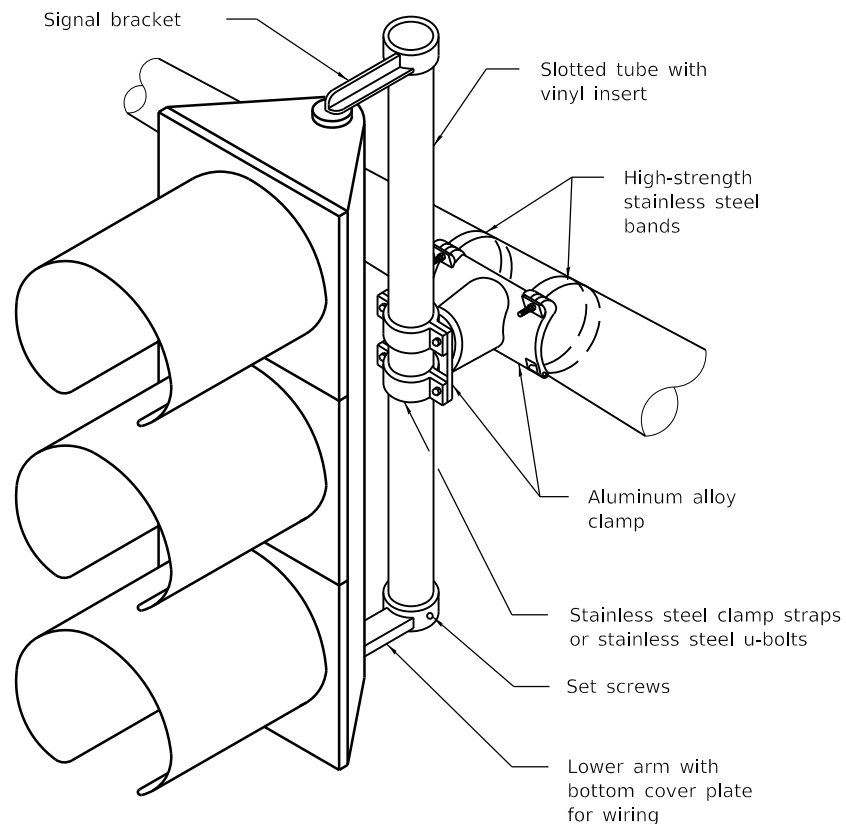

STEEL MAST ARM MOUNTING

Illinois Department of Transportation

PASSED January 1, 2009
Joe Hill
 ENGINEER OF OPERATIONS

APPROVED January 1, 2009
Ken E. Han
 ENGINEER OF DESIGN AND ENVIRONMENT

ISSUED 1-1-02

DATE	REVISIONS
1-1-09	Omitted note regarding units of length.
1-1-02	Renum. Standard 840006.

**TRAFFIC SIGNAL
MOUNTING DETAILS**

STANDARD 880006-01

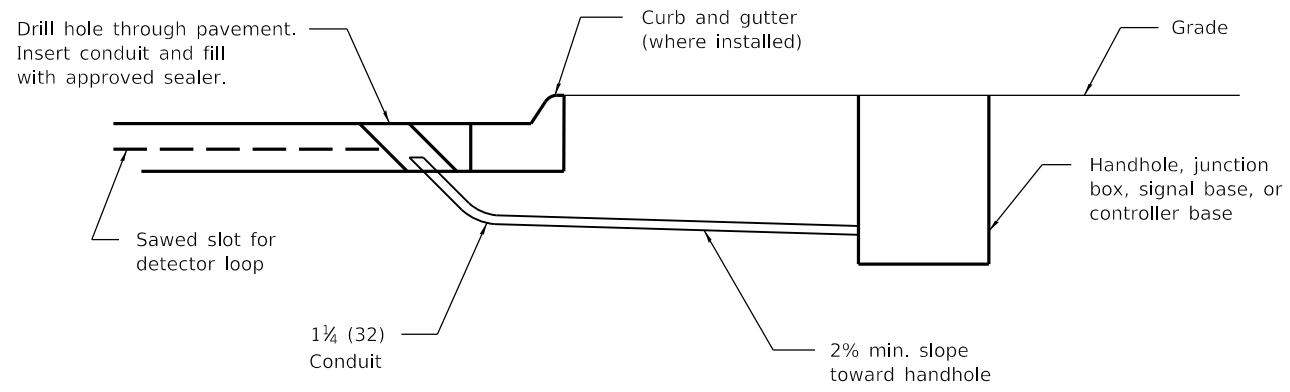

DETECTOR LOOP LEAD-IN

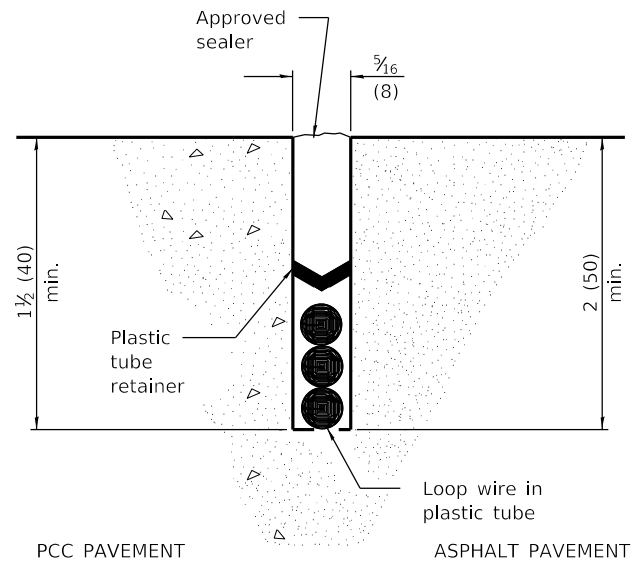

DETECTOR LOOP INSTALLATION

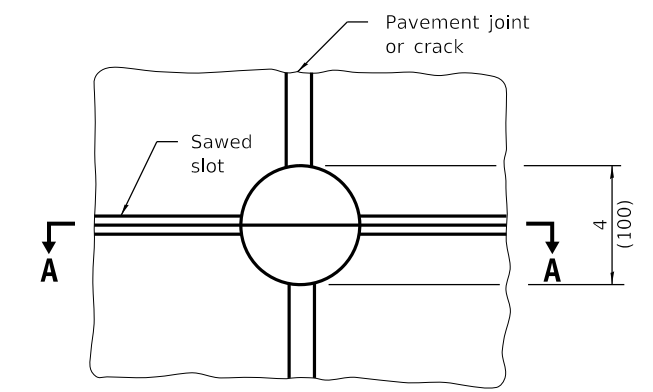

PLAN

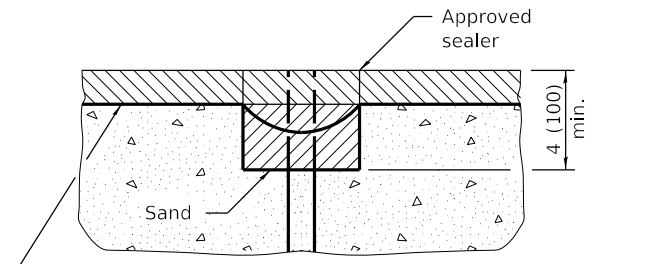

SECTION A-A

NOTE
Loop wire shall follow saw cut to bottom, forming slack section at joint.

DETECTOR LOOP AT PAVEMENT JOINT OR PAVEMENT CRACK

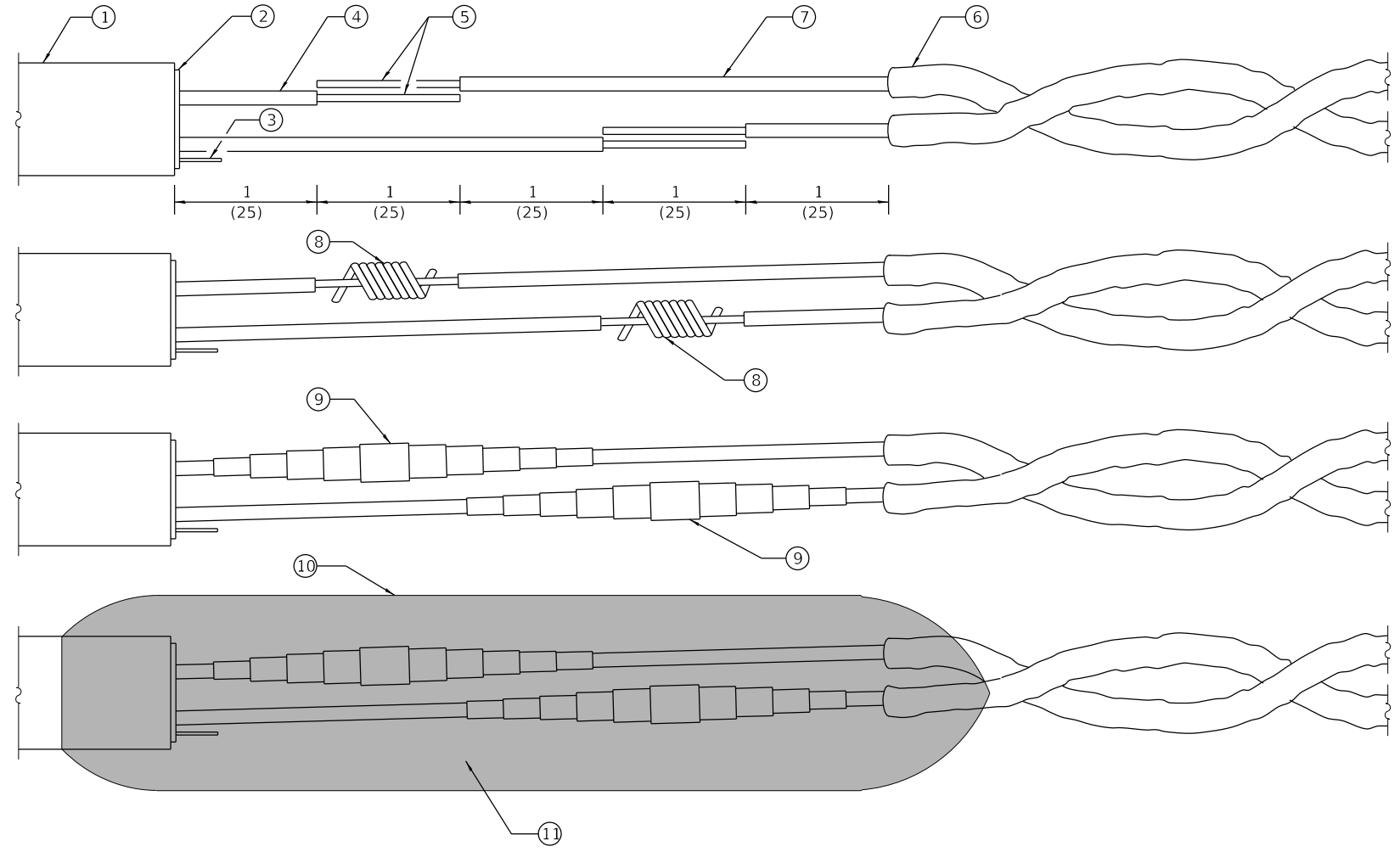

LOOP WIRE AND LEAD-IN CABLE SPLICE

- ① = Lead-in cable (single pair or multipair)
- ② = Lead-in cable shield
- ③ = Lead-in cable shield drain-wire
- ④ = Lead-in cable insulated conductor
- ⑤ = Bare conductor
- ⑥ = Loop wire in tube
- ⑦ = Loop wire insulated conductor
- ⑧ = Twisted and resin soldered conductor
- ⑨ = Electrical tape insulated splice
- ⑩ = Rigid mold
- ⑪ = Waterproof and dielectric resin

All dimensions are in inches (millimeters) unless otherwise shown.

Illinois Department of Transportation

PASSED January 1, 2009

ENGINEER OF OPERATIONS

APPROVED January 1, 2009

ENGINEER OF DESIGN AND ENVIRONMENT

ISSUED 1-1-02

DATE	REVISIONS
1-1-09	Switched units to English (metric)
1-1-02	Renum. Standard 846001.

DETECTOR LOOP INSTALLATIONS

STANDARD 886001-01

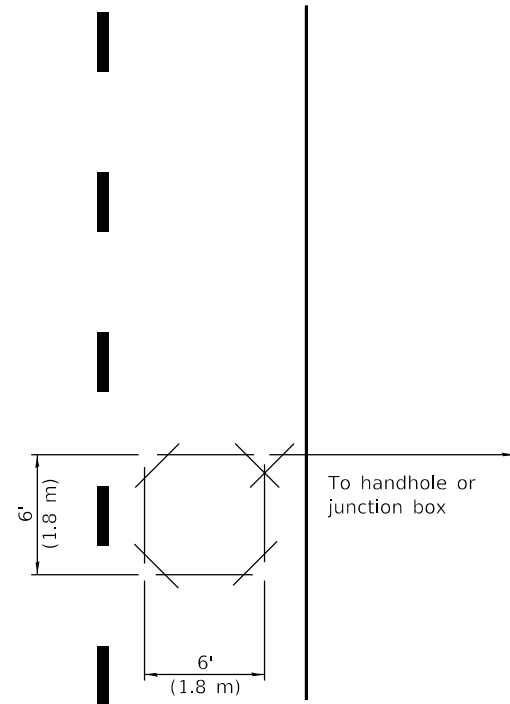

FOR POINT DETECTION
SHORT LOOP

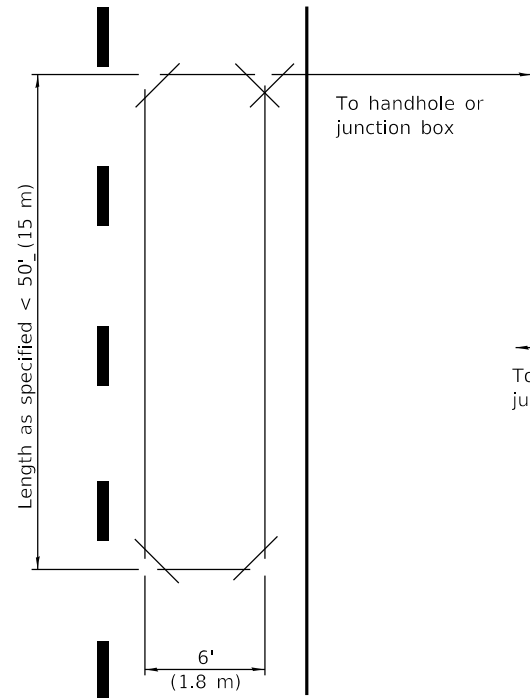

FOR PRESENCE DETECTION
LONG LOOP

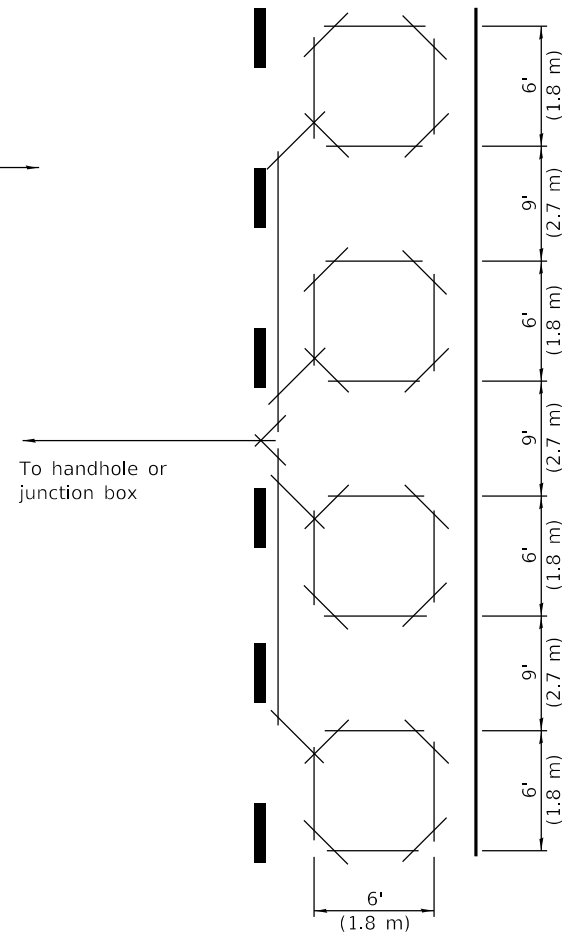

FOR PRESENCE DETECTION
MULTIPLE LOOP IN SERIES

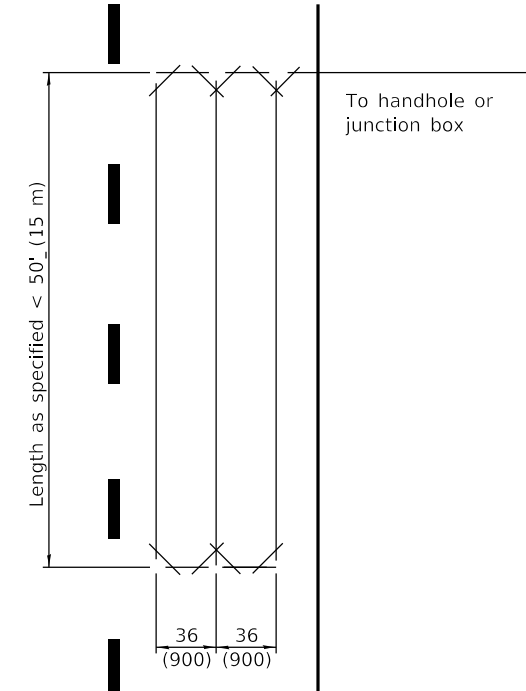

FOR PRESENCE DETECTION
QUADRUPOLE LOOP

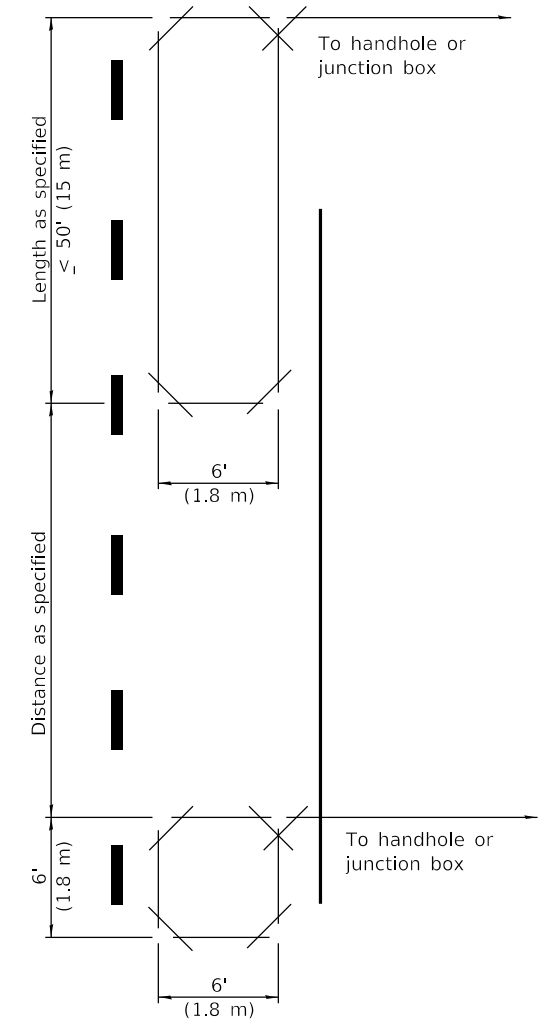

FOR EXTENDED-CALL DETECTION

SLOT PLAN

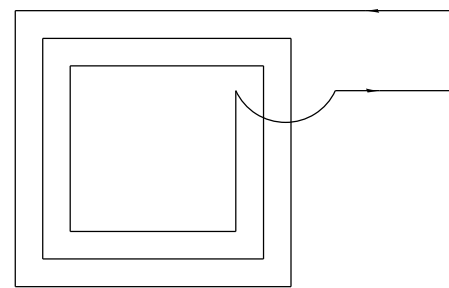

SHORT LOOP

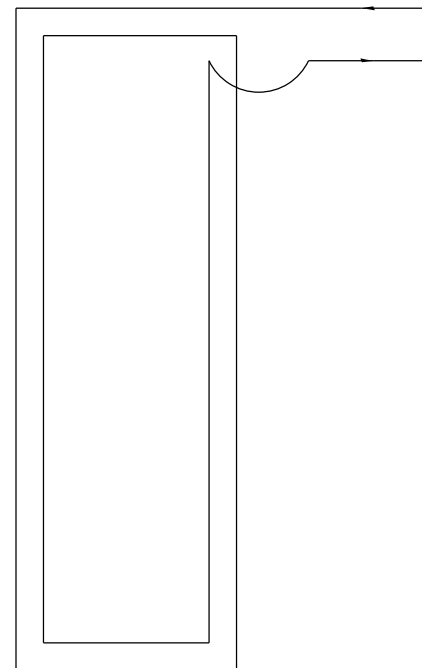

LONG LOOP

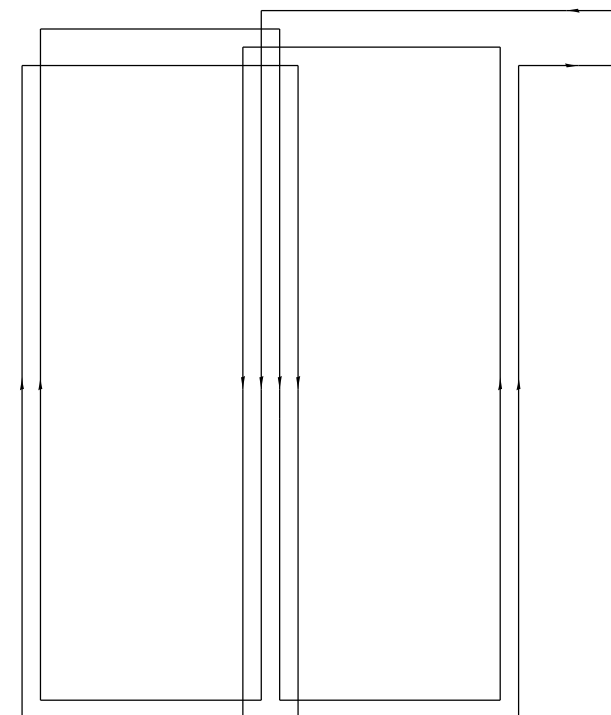

QUADRUPOLE LOOP

WIRING DIAGRAM

All dimensions are in inches (millimeters)
unless otherwise shown.

Illinois Department of Transportation

PASSED January 1, 2009
[Signature]
 ENGINEER OF OPERATIONS

APPROVED January 1, 2009
[Signature]
 ENGINEER OF DESIGN AND ENVIRONMENT

ISSUED 1-1-02

DATE	REVISIONS
1-1-09	Switched units to English (metric)
1-1-02	Renum. Standard 846006.

**TYPICAL LAYOUTS
FOR DETECTION LOOPS**

STANDARD 886006-01

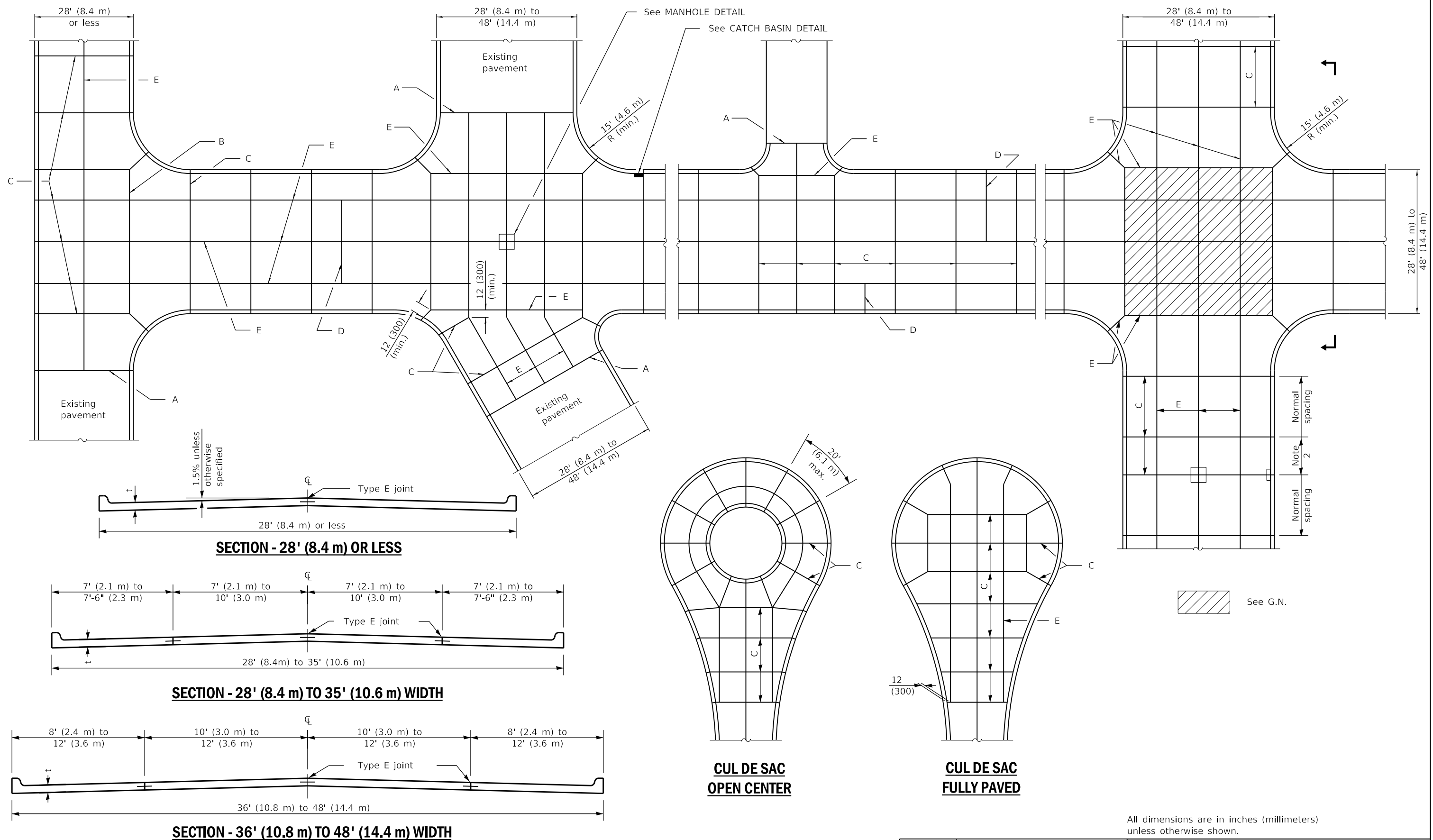

All dimensions are in inches (millimeters) unless otherwise shown.

DATE	REVISIONS
1-1-22	Revised spacing of transverse joints in General Notes.
1-1-18	Changed No. 6 (No. 19) bars to No. 5 (No. 16) bars.

**PCC PAVEMENT SPECIAL
(NONREINFORCED)**

(Sheet 1 of 2)

STANDARD B.L.R. 10-8

Illinois Department of Transportation

APPROVED January 1, 2022

ENGINEER OF LOCAL ROADS AND STREETS

APPROVED January 1, 2022

ENGINEER OF DESIGN AND ENVIRONMENT

ISSUED 1-1-97

t = See typical cross section on plans for thickness

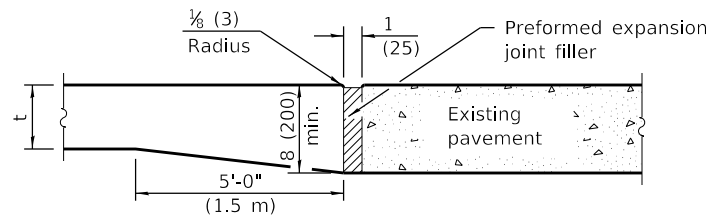

**TYPE A
EXPANSION JOINT**

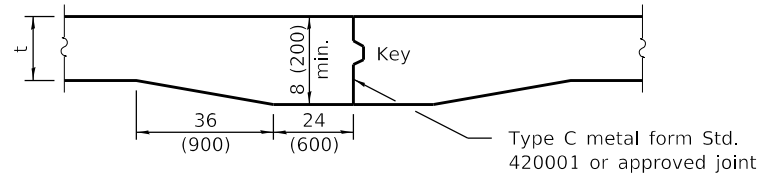

**TYPE B
KEYED JOINT**

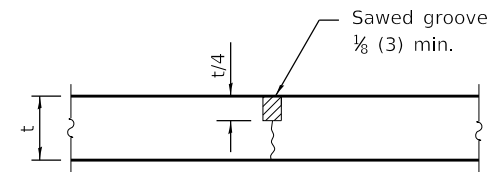

**TYPE C
SAWED TRANSVERSE JOINT**

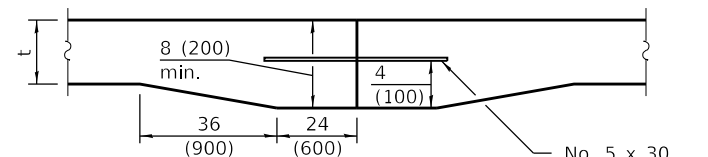

**TYPE D
TIED TRANSVERSE CONSTRUCTION JOINT**

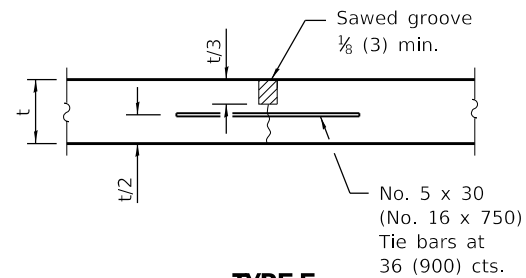

**TYPE E
SAWED LONGITUDINAL JOINT**

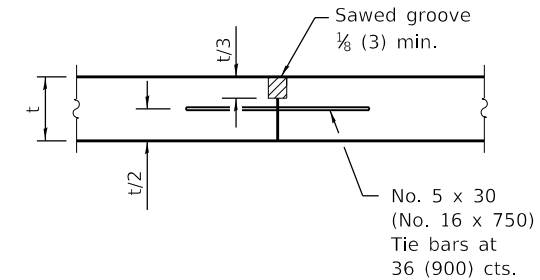

**TYPE E
LONGITUDINAL CONSTRUCTION JOINT**

GENERAL NOTES

All catch basins shall be separated from the pavement and curb by boxing out as shown in the detail. Manhole castings within the pavement limits shall be boxed in a like manner except when telescoping type castings are used.

When a joint falls within 5 ft. (1.5 m) of or contacts basins, manholes, or other structures, shorten one or more panels either side of opening to permit joint to fall at the corners of the box out.

When specified, roundouts as shown on Standard 420111 shall be used in lieu of the manhole detail shown herein except No. 5 (No. 16) bars shall be used in lieu of No. 6 (No. 19) bars.

All transverse joints must extend through curbs and be continuous across pavement, except tied transverse construction joints. Expansion joints will be required as shown on the plans.

When specified, the pavement structure thickness at intersections shall be increased. This requirement generally will occur when the design traffic through the intersection exceeds the typical design of the pavement structure either side of the intersection.

Joints shall be sawed to a depth of t/4 for transverse joints and t/3 for longitudinal joints. Saw joints shall be sealed with material meeting the requirements of Section 1050 of the Standard Specifications.

This alternate construction is at the Contractor's option and shall be constructed in accordance with Section 606 of the Standard Specifications. The combination concrete curb and gutter shall be measured in place and the area computed in sq yd (sq m). This work will be paid for at the contract unit price per sq yd (sq m) for portland cement concrete pavement special with integral curb of the thickness specified.

Transverse joint spacing shall not exceed 12' (3.6 m) for pavements less than 10 (250) thick or 15' (4.5 m) for pavements 10 (250) thick and greater.

Construct TYPE D tied transverse construction joint when construction joint does not fall at a TYPE C sawed transverse joint.

**PCC PAVEMENT SPECIAL
(NONREINFORCED)**

(Sheet 2 of 2)

STANDARD B.L.R. 10-8

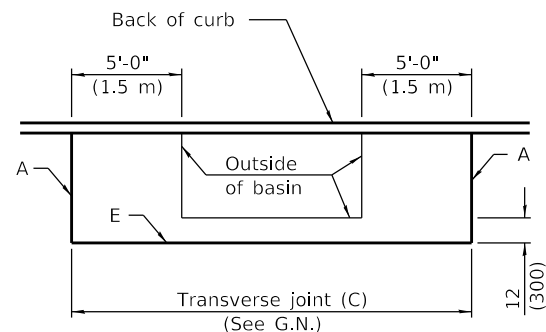

CATCH BASIN DETAIL

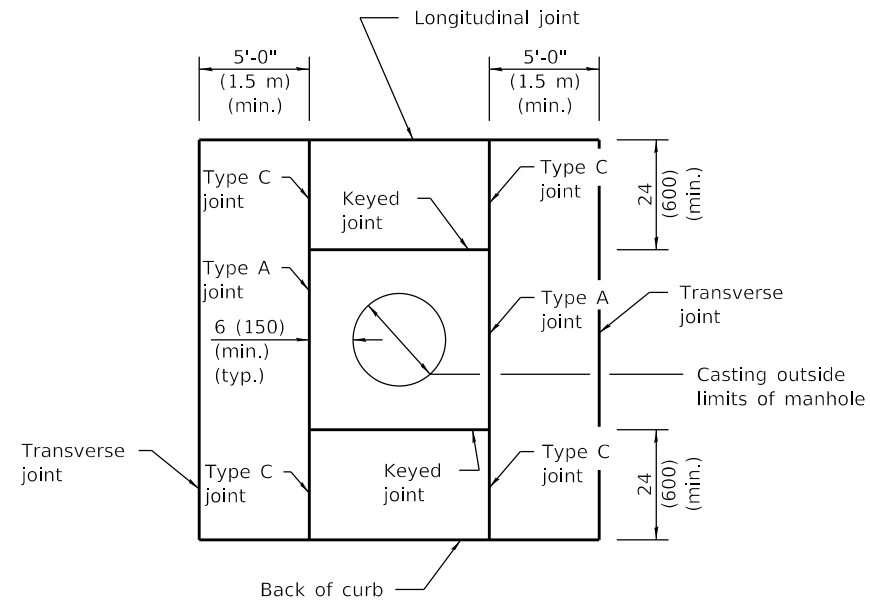

MANHOLE DETAIL
Showing Joint types

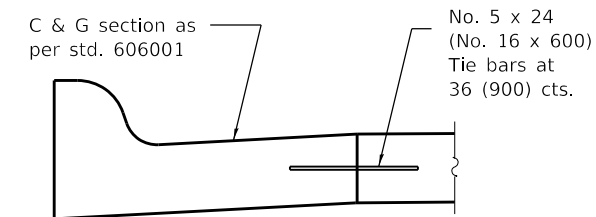

COMB. CURB & GUTTER DETAIL
Alt. const. see G.N.

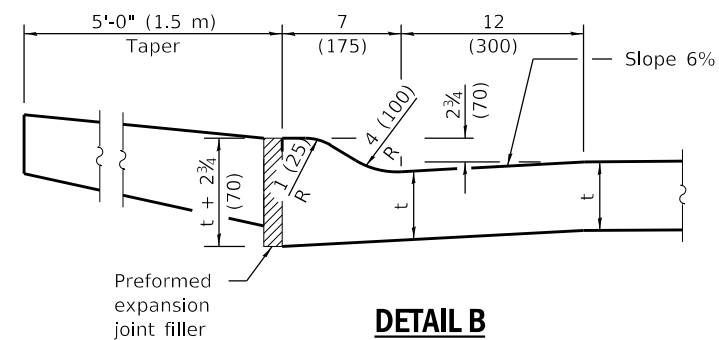

DETAIL B

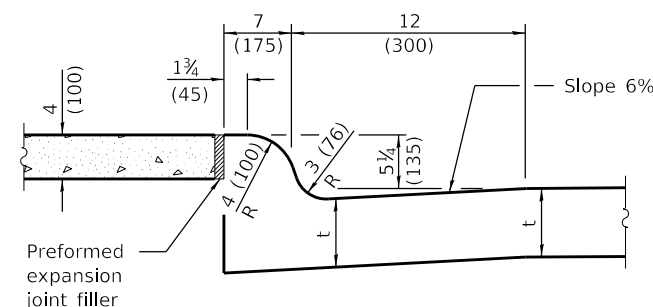

DETAIL A

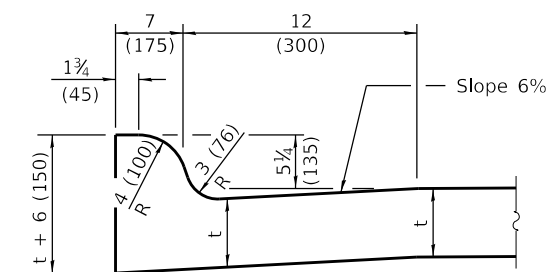

INTEGRAL CURB
See DETAIL A for crosswalks and DETAIL B for driveways.

Illinois Department of Transportation

APPROVED January 1, 2022

ENGINEER OF LOCAL ROADS AND STREETS

APPROVED January 1, 2022

ENGINEER OF DESIGN AND ENVIRONMENT

ISSUED 1-1-97

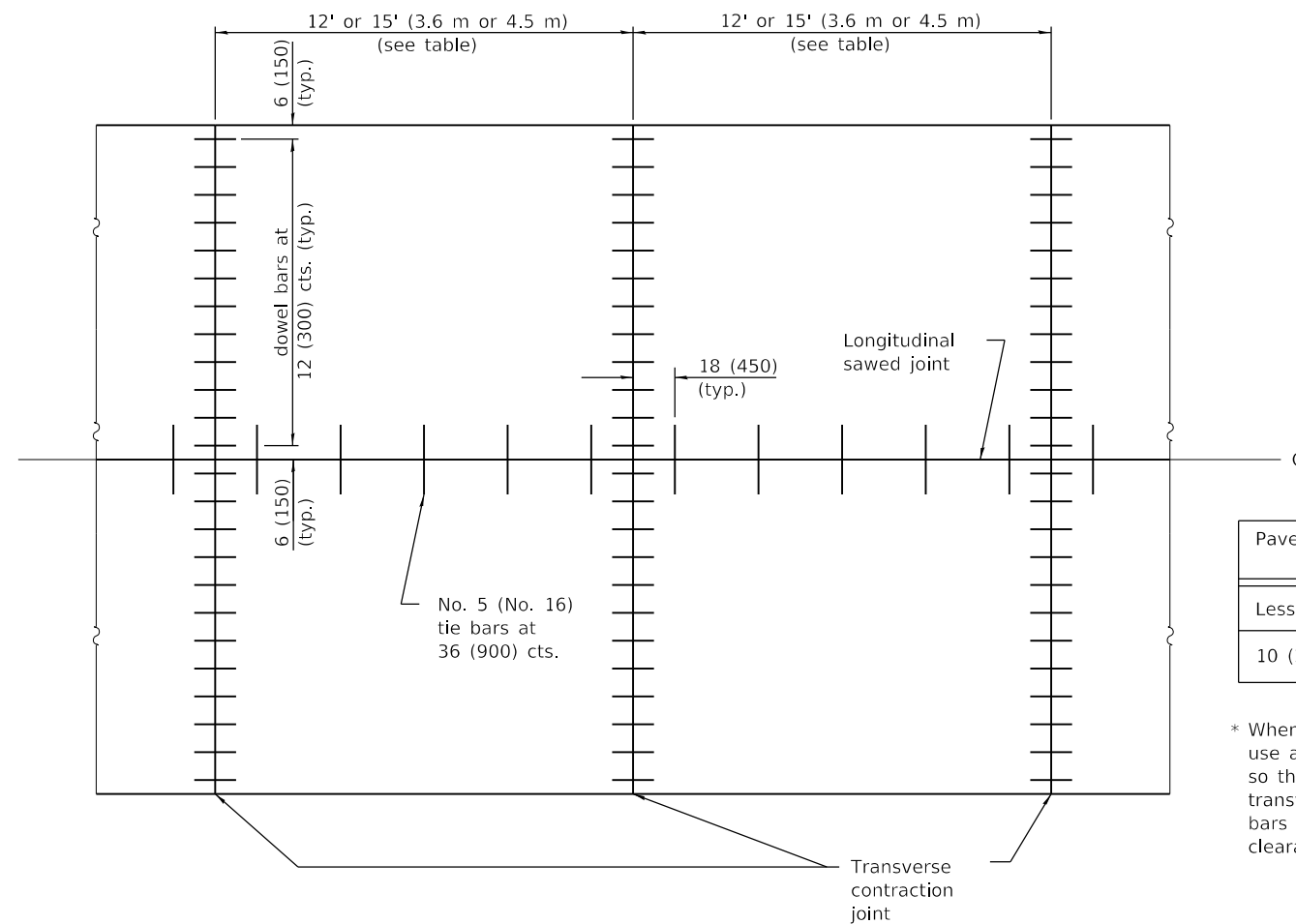

PLAN OF PAVEMENT

Pavement Thickness	Spacing of Transverse Contraction Joints
Less than 10 (250)	12' (3.6 m) *
10 (250) and greater	15' (4.5 m) *

* When placed adjacent to existing PCC pavement, use a spacing between 12' (3.6 m) and 18' (5.5 m) so the joints are in prolongation with existing transverse joints. Also adjust the spacing of tie bars in the longitudinal joint(s) to maintain a clearance of 9 (225) from the end of the dowel bars.

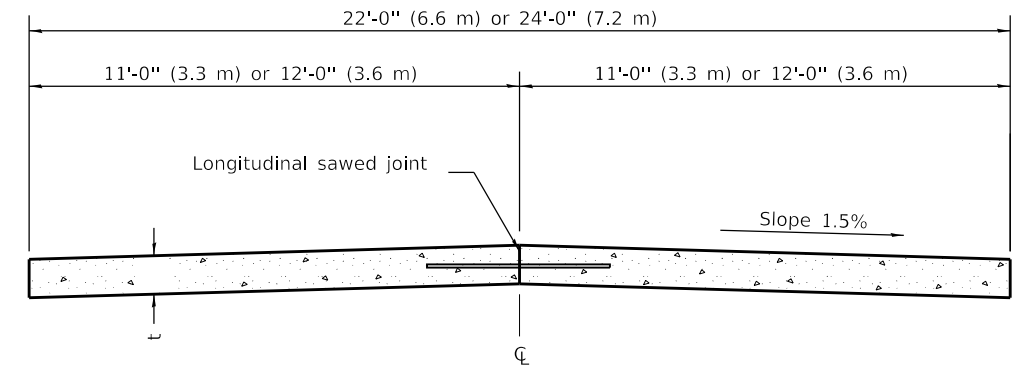

CROSS SECTION OF PAVEMENT

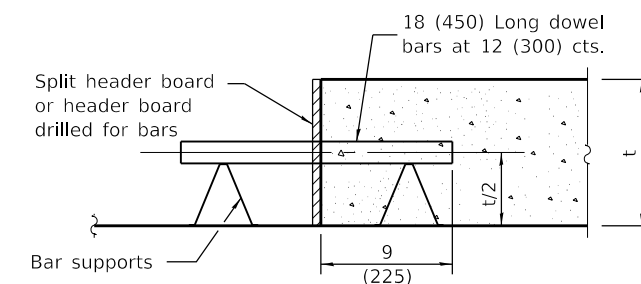

TRANSVERSE CONSTRUCTION JOINT

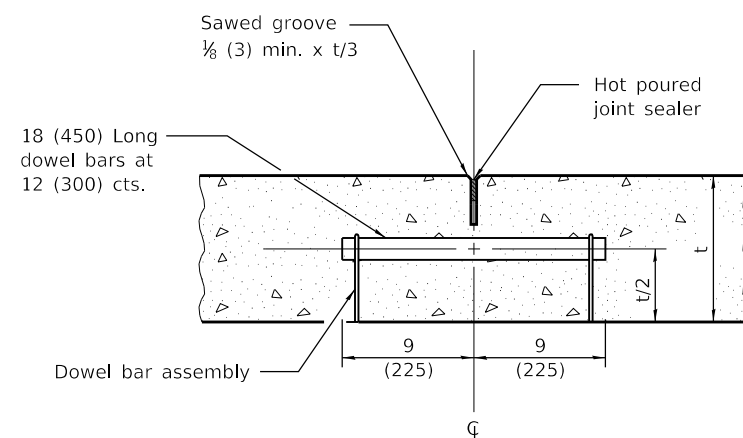

TRANSVERSE CONTRACTION JOINT

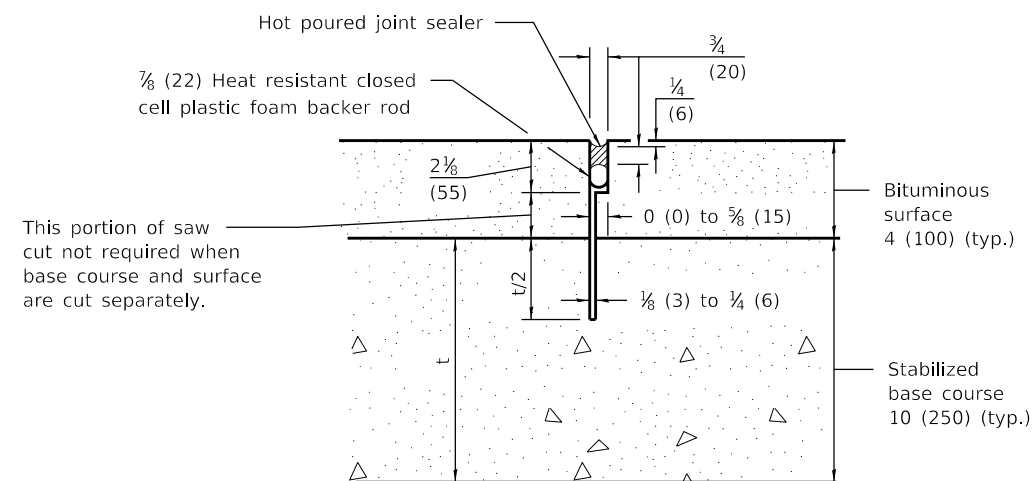

TRANSVERSE CONTRACTION JOINT

(For CAM, CFA and LFA Base Course Mixtures)

GENERAL NOTES

See Standard 420001 for details of Transverse Expansion Joints, Longitudinal Sawed Joints and Longitudinal Construction Joints.

Dowel bars are only required for Class I, II, or III Roads and Streets having pavement thickness of 7 (175) or greater.

t = Pavement thickness (See Typical Cross Section)

All dimensions are in inches (millimeters) unless otherwise shown.

DOWEL BAR TABLE

PAVEMENT THICKNESS	DOWEL BAR DIAMETER
10 (250) and greater	1 1/2 (38)
8.01 (201) to 9.99 (249)	1 1/4 (32)
8 (200) and less	1 (25)

DATE	REVISIONS
1-1-22	Revised spacing of transverse contraction joints, dowel bar table and header board callout.
1-1-18	Revised dowel and tie bar sizes. Increased tie bar spacing.
	Eliminated skewed joint.

PORTLAND CEMENT CONCRETE PAVEMENT (NONREINFORCED)

STANDARD B.L.R. 14-13

Illinois Department of Transportation

PASSED January 1, 2022

ENGINEER OF LOCAL ROADS AND STREETS

APPROVED January 1, 2022

ENGINEER OF DESIGN AND ENVIRONMENT

ISSUED 1-1-97

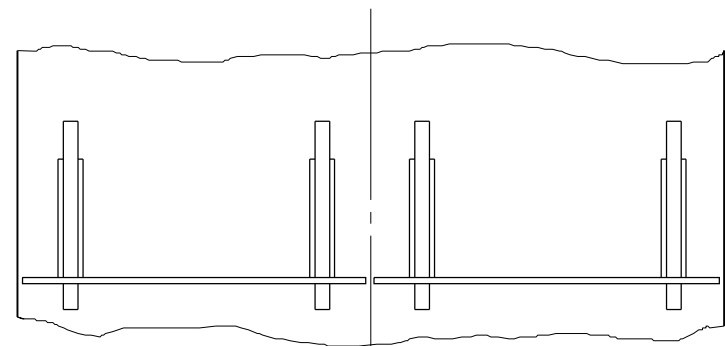

Type III Barricades with Standard Sign R11-2 or R11-4 mounted as shown.

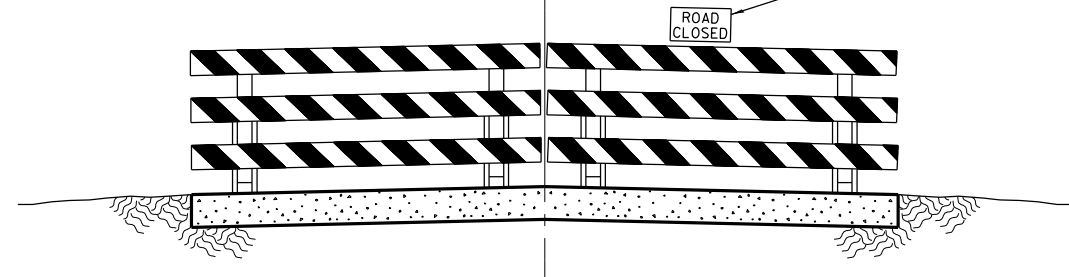

Resident traffic and day labor force's equipment to use road shoulder for passing barricade.

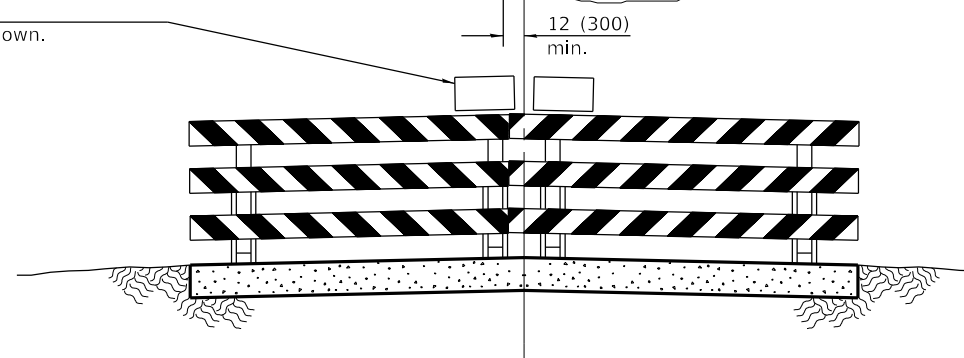
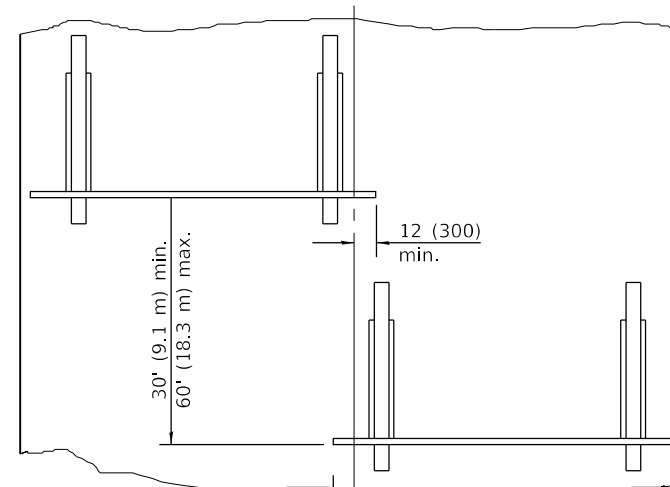

Use when shoulders are too narrow for passage of traffic.

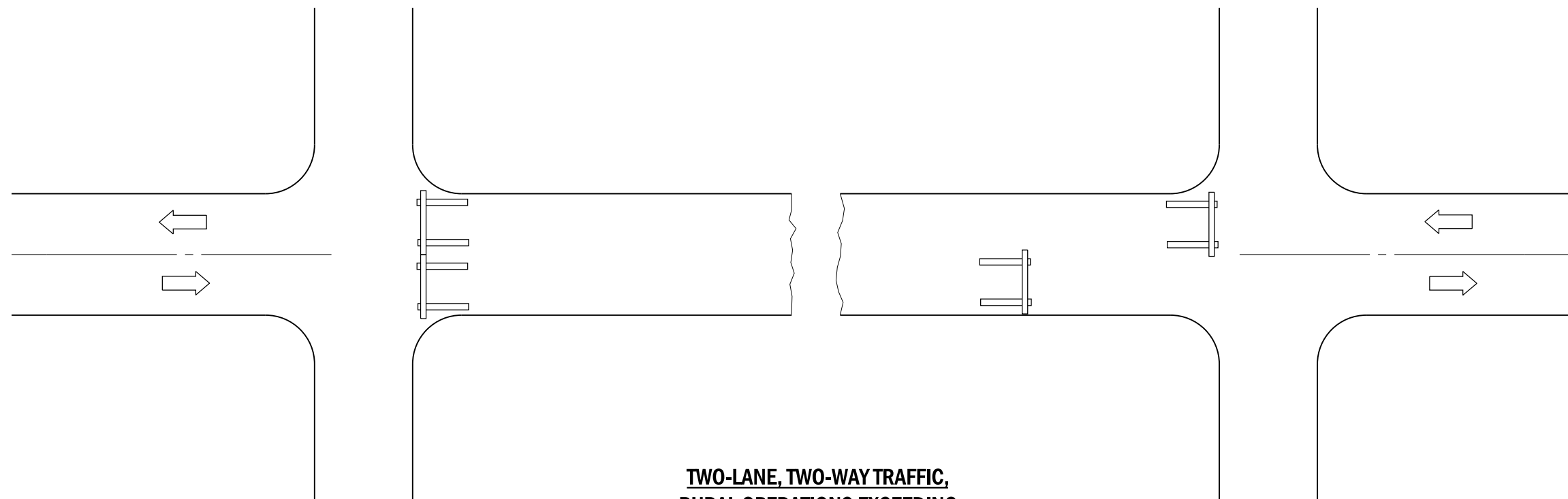

**TWO-LANE, TWO-WAY TRAFFIC,
RURAL OPERATIONS EXCEEDING
ONE DAYLIGHT PERIOD**

GENERAL NOTES

Type III barricades to be width of pavement only.

Reflectorized striping shall appear on both sides of barricades. Barricades shall be positioned so that stripes slope downward toward the side on which traffic is to pass.

Although not shown, advance warning signs with minimum dimensions of 36x36 (900x900) and black legends on orange reflectorized backgrounds shall be utilized where needed.

This case is for use on rural local roads where the local authority considers this protection to be appropriate for the specific job conditions.

All dimensions are in inches (millimeters) unless otherwise shown.

DATE	REVISIONS
1-1-09	Switched units to English (metric).
1-1-98	Rev. "R11-1" to "R11-4".
	Rev. 4th General Note.

**TRAFFIC CONTROL DEVICES -
DAY LABOR CONSTRUCTION**

STANDARD B.L.R. 17-4

Illinois Department of Transportation

PASSED January 1, 2009
Charles J. Ringwald
 ENGINEER OF LOCAL ROADS AND STREETS

APPROVED January 1, 2009
Ken E. Han
 ENGINEER OF DESIGN AND ENVIRONMENT

ISSUED 1-1-97

* Minimum distance between the sign and the work area is 700' (215 m). Maximum distance to be determined by the local authority but in no case to exceed the length of one-half day's operation or 4 miles (6 km), whichever is less.

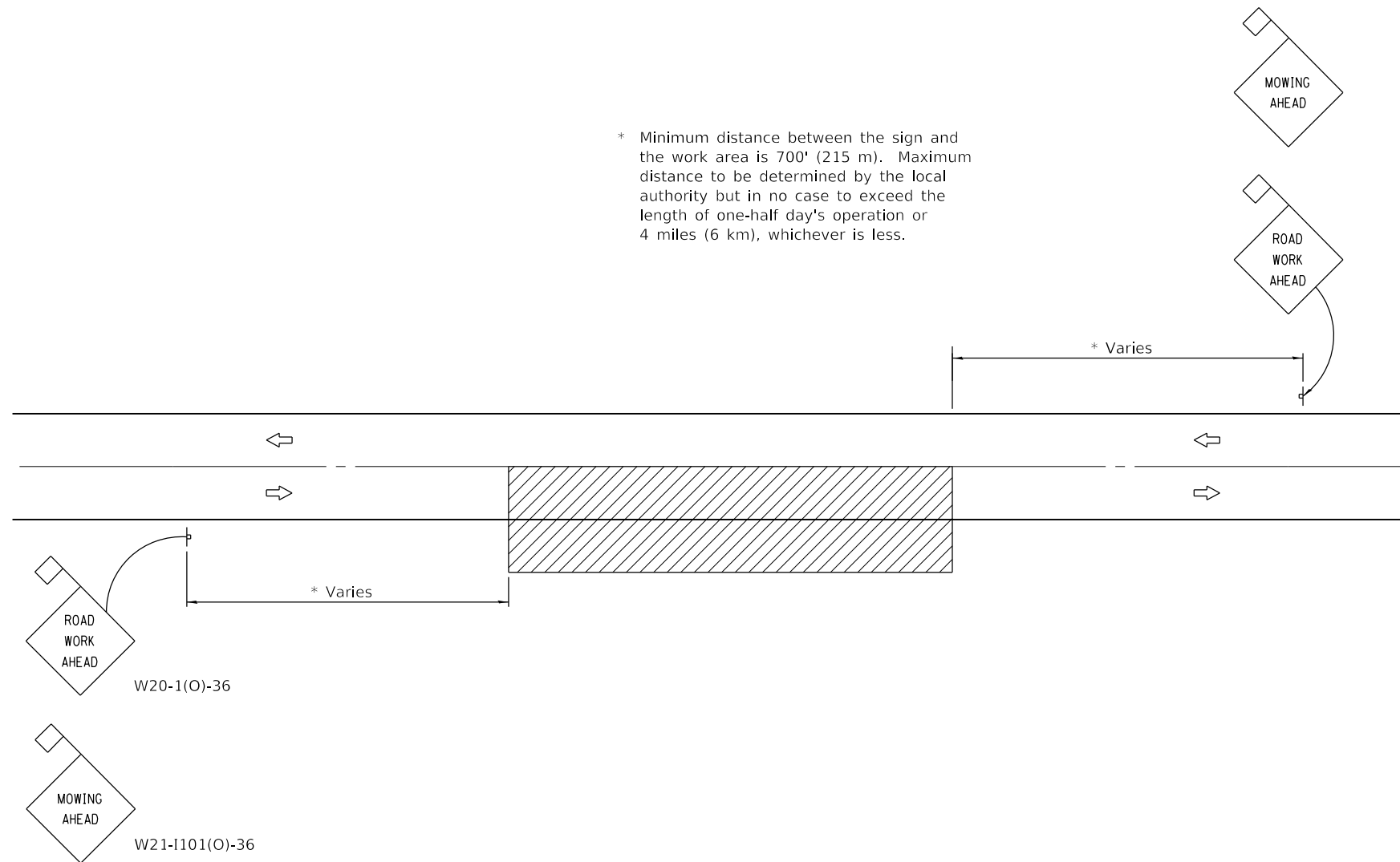

TWO-LANE, TWO-WAY TRAFFIC
RURAL OPERATIONS
DAY OPERATIONS ONLY

SYMBOLS



Work area



Sign with 18x18 (450x450) min. orange flag attached.

TYPICAL APPLICATIONS

- MOWING
- SPREADING AGGREGATE
- WEED SPRAYING
- SURFACE MAINTENANCE
- BITUMINOUS RESURFACING
- CRACK POURING
- SHOULDER REPAIR
- CLEANING DITCHES

GENERAL NOTES

Maintenance operations shall be confined to one traffic lane, leaving the opposite lane open to traffic. At least 500' (150 m) of both traffic lanes shall be available for traffic movement between work areas at intervals not greater than 1000' (300 m).

When operations are on the pavement and stationary or moving at a speed less than 4 mph (6 kph), a ONE LANE AHEAD, or other appropriate sign, shall be installed in each direction between the ROAD WORK AHEAD sign and the work area. The distance between this sign and the work area shall be a minimum of 400' (120 m) but in no case to exceed the length of one-half day's operation or 4 miles (6 km), whichever is less. The distance between the two signs shall be approximately 400' (120 m).

All signs are to be removed at completion of the day's operation.

Any unattended obstacle, excavation, or pavement drop off greater than 3 (75) in the work area shall be protected by Type I or Type II barricades with flashing lights.

Longitudinal dimensions may be adjusted slightly to fit field conditions.

All vehicles, equipment, men, and their activities are restricted at all times to one side of the pavement.

Flashing lights or rotating beacons are required for all maintenance vehicles while in operation.

Applicable operations illustrated in Standard 701301 may be used when operations do not exceed 15 minutes on the pavement or 60 minutes on the shoulder respectively.

All warning signs shall have minimum dimensions of 36x36 (900x900) and have black legend on an orange reflectorized background.

When fluorescent signs are used, orange flags are not required.

This case is for use on rural local roads where the local authority considers this protection to be appropriate for the specific job conditions.

All dimensions are in inches (millimeters) unless otherwise shown.

Illinois Department of Transportation

PASSED January 1, 2015
Jamie K. Klein
 ENGINEER OF LOCAL ROADS AND STREETS

APPROVED January 1, 2015
[Signature]
 ENGINEER OF DESIGN AND ENVIRONMENT

ISSUED 1-1-97

DATE	REVISIONS
1-1-15	Corrected RWA sign number.
1-1-09	Switched units to English (metric). Moved one General Note.

**TRAFFIC CONTROL DEVICES-
 DAY LABOR MAINTENANCE**

STANDARD B.L.R. 18-6

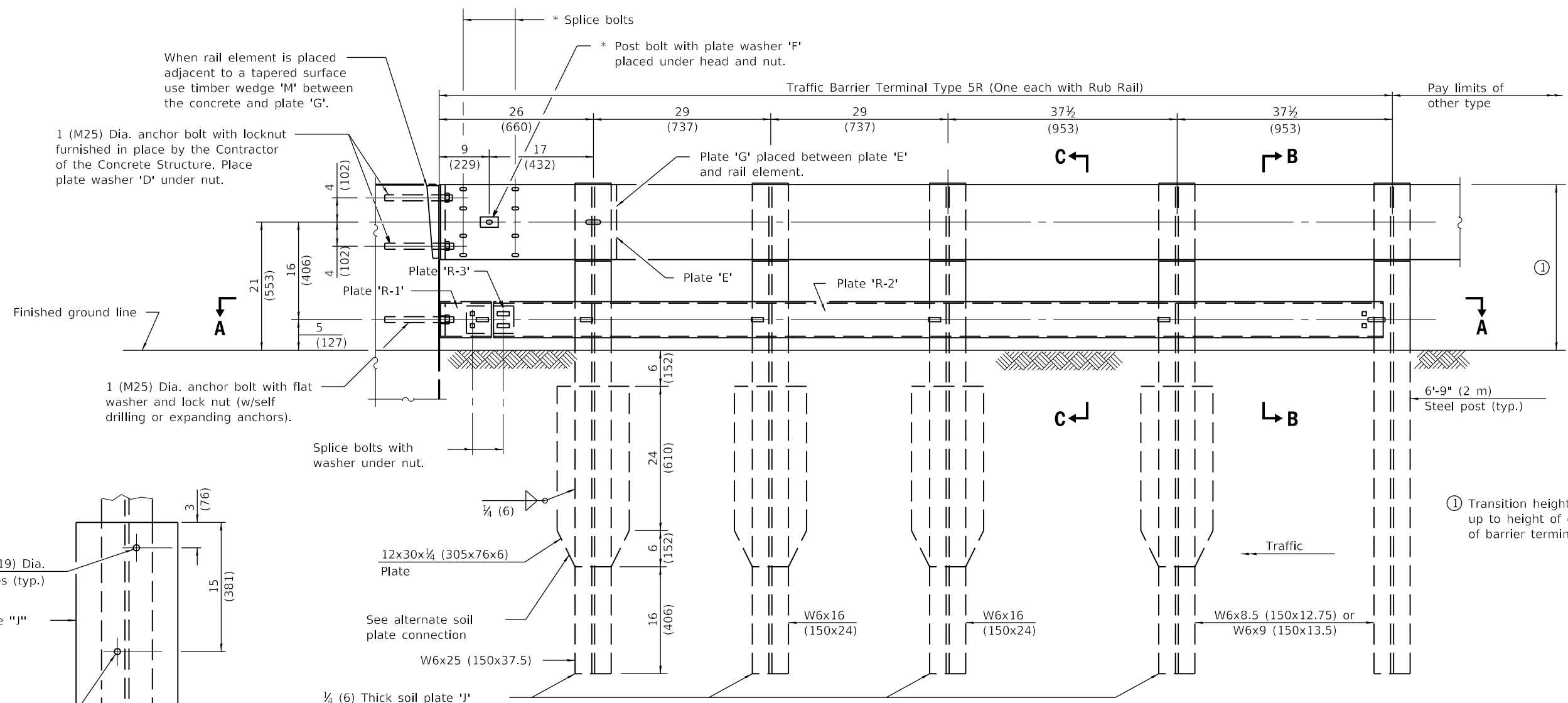

① Transition height of barrier terminal up to height of guardrail over length of barrier terminal.

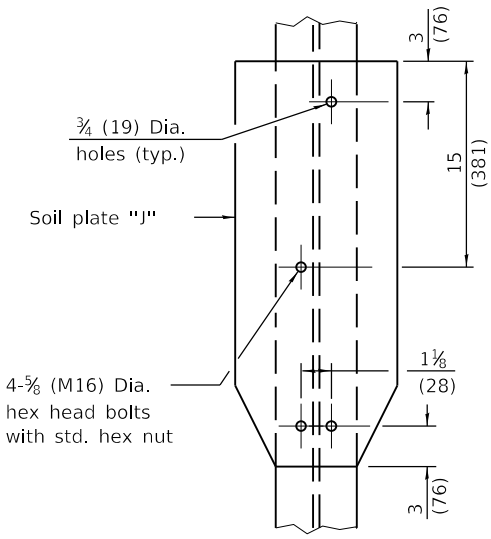

ALTERNATE SOIL PLATE CONNECTION

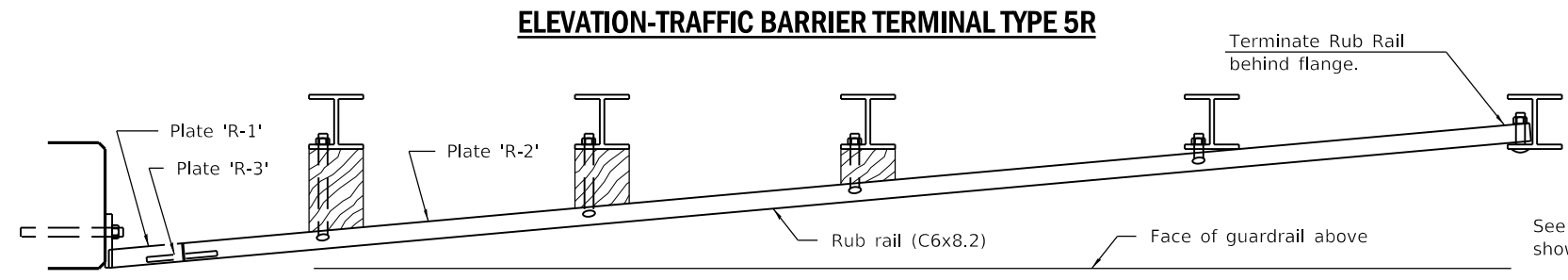

SECTION A-A

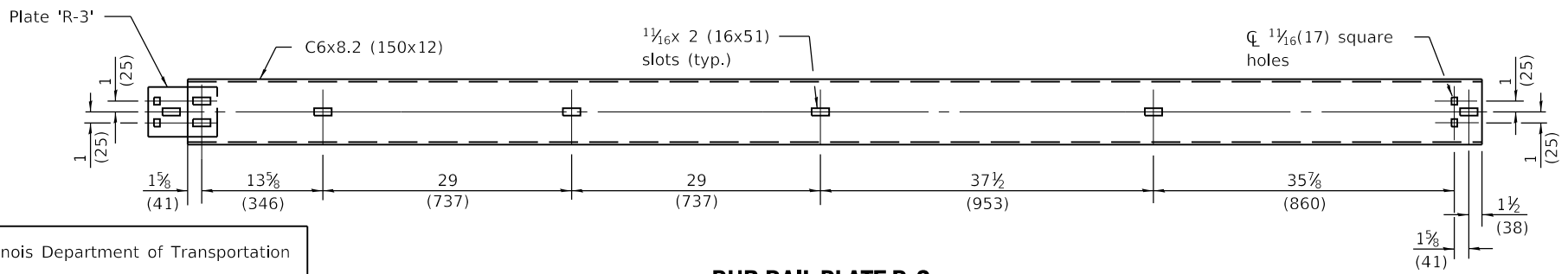

RUB RAIL PLATE R-2

GENERAL NOTES

- See Standard B.L.R. 26 for details of guardrail not shown.
- Install the face of the guardrail flush with the face of the parapet. Install plate washer "D" so that the 1 (25) projection fills the remainder of the slotted holes in the 1 (25) end plate on plate "G" after the 1 (25) bolts are in place.
- * When an expansion joint exists below the connector, bolts shall be provided with locknut or double nut and shall be tightened only to a point that will allow plate G to be free to move.
- All dimensions are in inches (millimeters) unless otherwise shown.

DATE	REVISIONS
1-1-12	Revised barrier terminal height per note . ①
1-1-09	Switched units to English (metric).

TRAFFIC BARRIER TERMINAL-TYPE 5R

(Sheet 1 of 2)

STANDARD B.L.R. 20-7

Illinois Department of Transportation

PASSED January 1, 2012

Donell Lewis
ENGINEER OF LOCAL ROADS AND STREETS

APPROVED January 1, 2012

Scott S. ...
ENGINEER OF DESIGN AND ENVIRONMENT

ISSUED 1-1-12

76-1

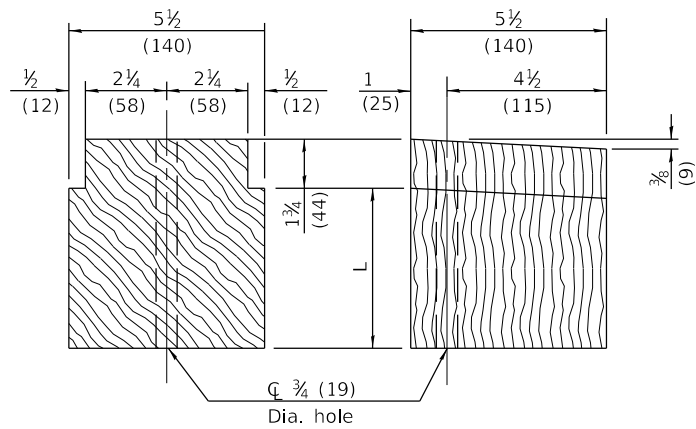

TREATED TIMBER BLOCKING

** Approximate Lengths Field Verify

** L
7 3/8 (187)
5 5/8 (143)
3 7/8 (98)

3/8 (16) Dia. post bolt with 3/4 (19) Dia. hole in post

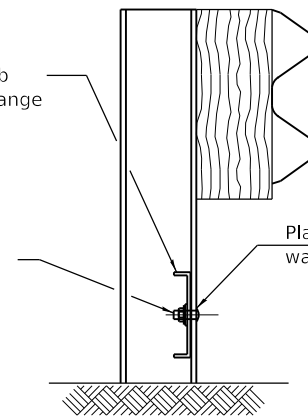

SECTION B-B

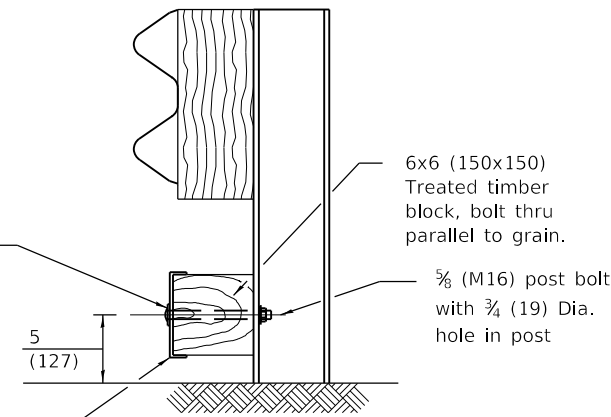

SECTION C-C

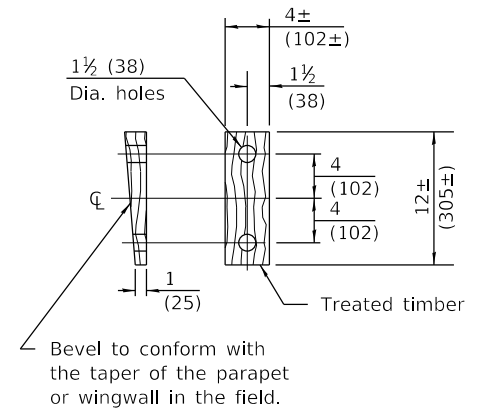

WEDGE M

Bevel to conform with the taper of the parapet or wingwall in the field.

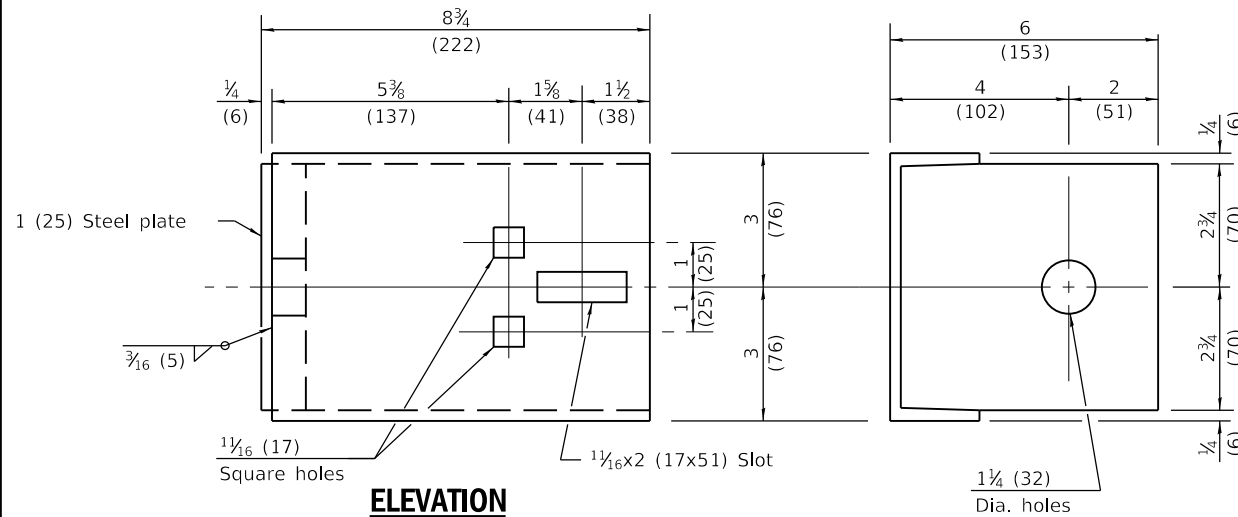

ELEVATION

END VIEW

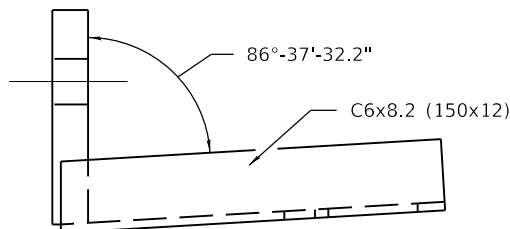

PLAN

RUB RAIL PLATE R-1

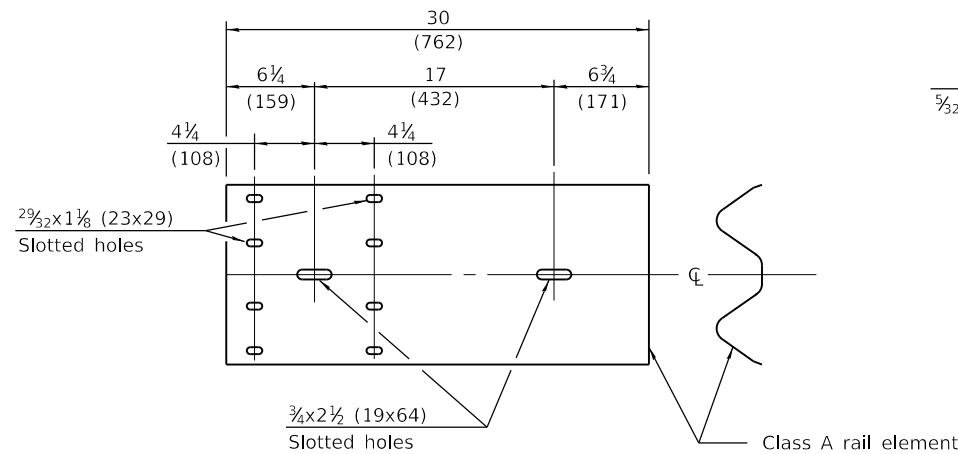
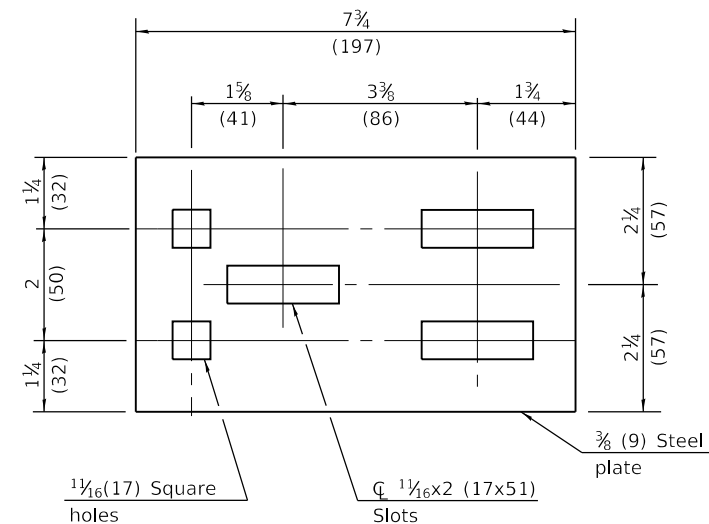

PLATE E



SPLICE PLATE 'R-3'

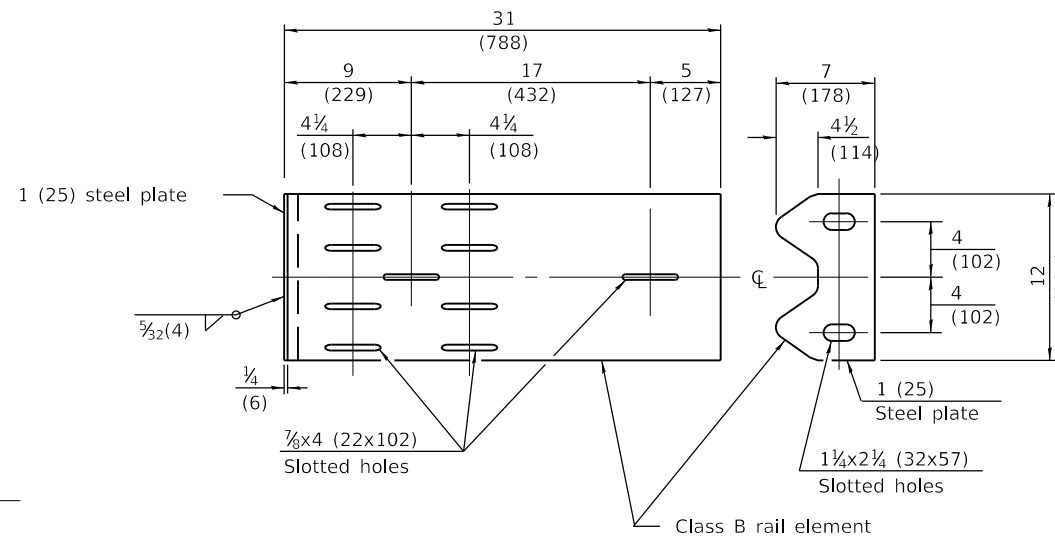

PLATE G

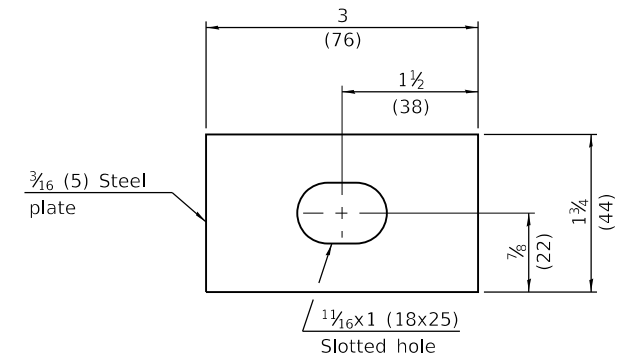

PLATE WASHER F

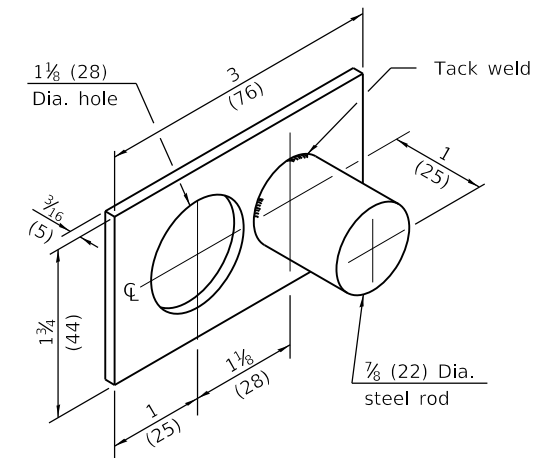

PLATE WASHER D

**TRAFFIC BARRIER
TERMINAL-TYPE 5R**

(Sheet 2 of 2)

STANDARD B.L.R. 20-7

Illinois Department of Transportation

PASSED January 1, 2012

APPROVED January 1, 2012

ISSUED 1-1-97

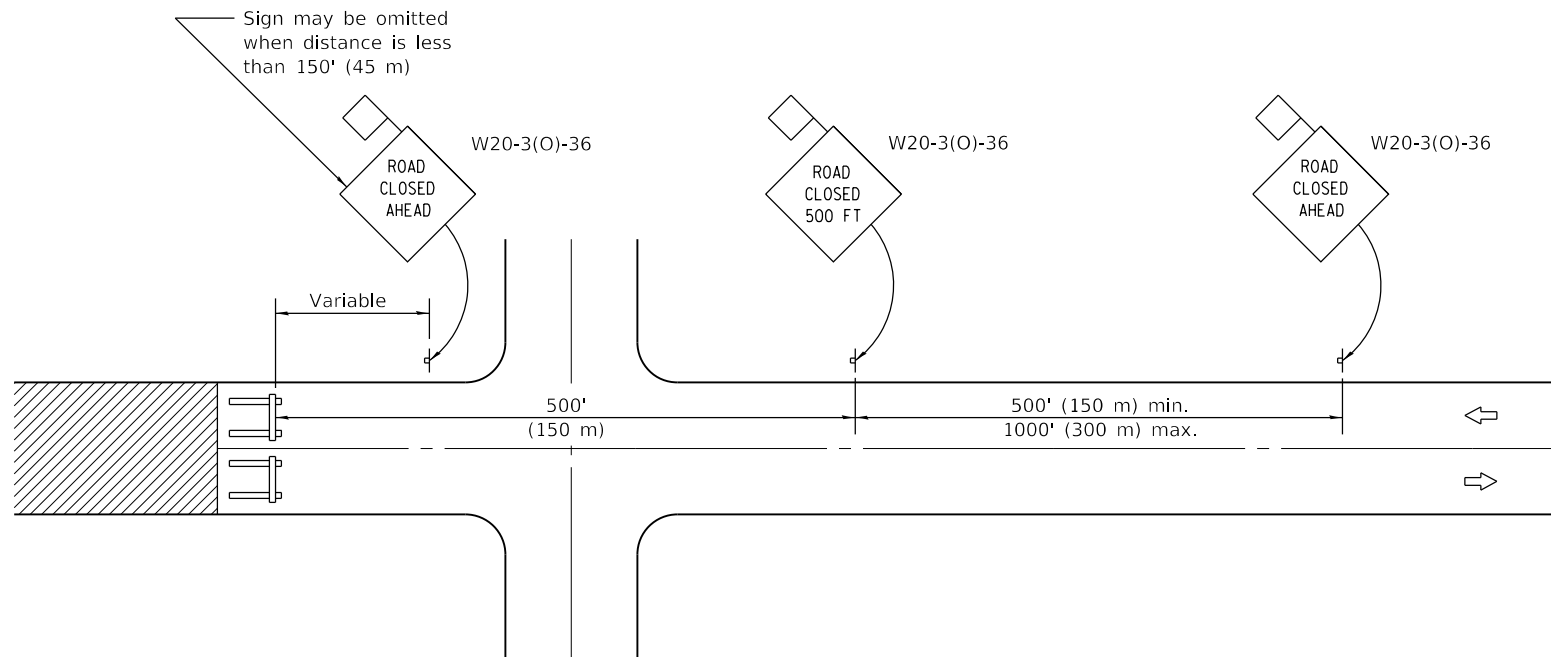

CONDITION I

When distance from closure to crossroad is less than 1500' (450 m)

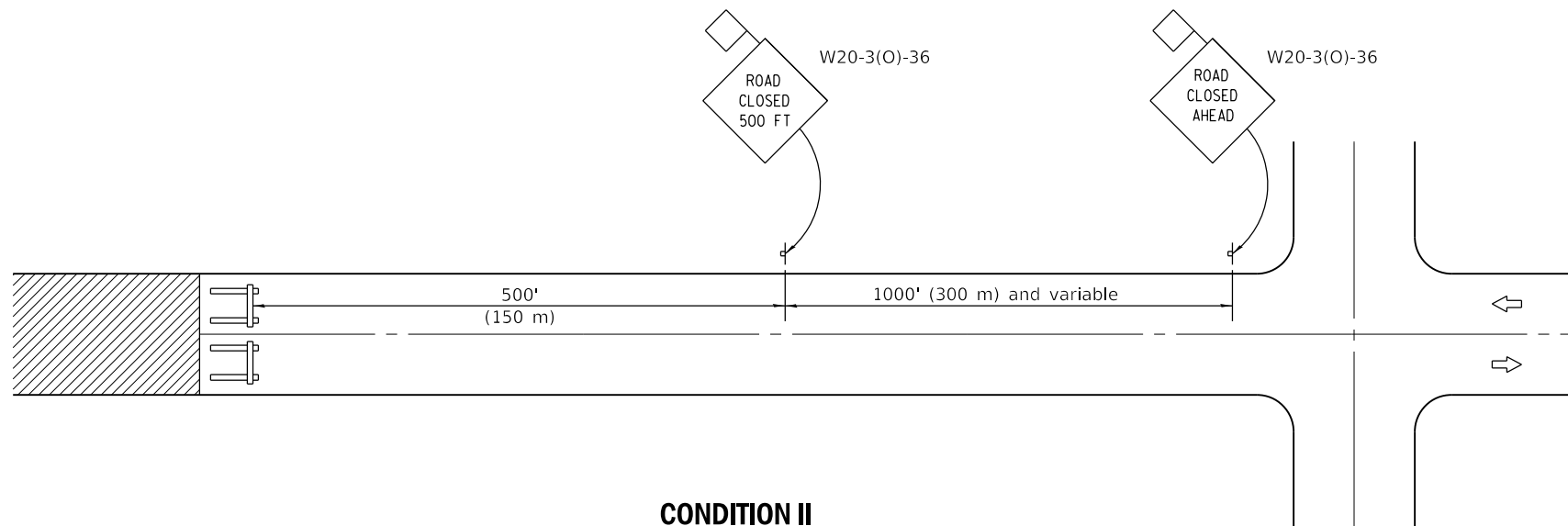

CONDITION II

When distance from closure to crossroad is greater than 1500' (450 m)

SYMBOLS

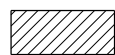

Work area



Type III Barricade



Sign with 18x18 (450x450) min. orange flag attached

GENERAL NOTES

Type III Barricades and R11-2-4830 signs shall be positioned as shown in "Road Closed To All Traffic" detail on Highway Standard 701901.

Two Type A Low Intensity Flashing Lights shall be used on each approach in advance of the work area during hours of darkness. One light shall be installed above the barricades and the other above the first advance warning sign.

All warning signs shall have minimum dimensions of 36 x 36 (900 x 900) and have a black legend on an orange reflectorized background.

When fluorescent signs are used, orange flags are not required.

Longitudinal dimensions may be adjusted to fit field conditions.

When the distance between the barricade and the intersection is between 1500' (450 m) and 2000' (600 m), the advance sign shall be placed at the intersection. When the distance between the barricade and the intersection is over 2000' (600 m), an additional sign shall be placed at the intersection. The additional sign shall give the distance to the barricade in miles or fractions of a mile.

All dimensions are in inches (millimeters) unless otherwise shown.

DATE	REVISIONS
1-1-12	Omitted two notes from GENERAL NOTES.
1-1-09	Switched units to English (metric).

TYPICAL APPLICATION OF TRAFFIC CONTROL DEVICES FOR CONSTRUCTION ON RURAL LOCAL HIGHWAYS

STANDARD B.L.R. 21-9

Illinois Department of Transportation

PASSED January 1, 2012
Danell Lewis
 ENGINEER OF LOCAL ROADS AND STREETS

APPROVED January 1, 2012
Scott S. S. S.
 ENGINEER OF DESIGN AND ENVIRONMENT



ISSUED 1-1-97

**CONDITION I
APPROACH TRAFFIC STOPPED**

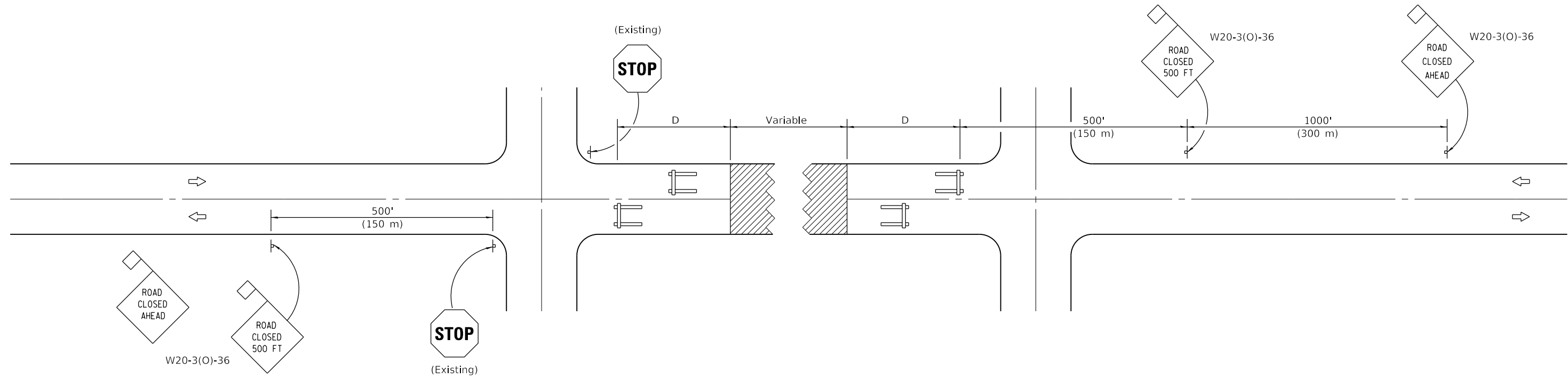
**CONDITION II
APPROACH TRAFFIC
DOES NOT STOP**



SYMBOLS

-  Work area
-  Type III Barricade
-  Sign with 18x18 (450x450) min. orange flag attached

GENERAL NOTES

Type III Barricades and R11-4-6030 signs shall be positioned as shown in the "Road Closed To All Traffic" detail on Highway Standard 701901. If the distance "D" exceeds 2000' (600 m), an additional set of barricades and R11-4-6030 shall be placed at each end of the work area.

Two Type A Low Intensity Flashing Lights shall be used on each approach in advance of the work area. One light shall be installed above each barricade. If only one barricade is required, the other light shall be installed above the first advance warning sign.

All warning signs shall have minimum dimensions of 36 x 36 (900 x 900) and have a black legend on an orange reflectorized background.

When fluorescent signs are used, orange flags are not required.

Longitudinal dimensions may be adjusted to fit field conditions.

All dimensions are in inches (millimeters) unless otherwise shown.

DATE	REVISIONS
1-1-12	Omitted two notes from GENERAL NOTES.
1-1-09	Revised General Notes and switched units to English (metric).

TYPICAL APPLICATION OF TRAFFIC CONTROL DEVICES FOR CONSTRUCTION ON RURAL LOCAL HIGHWAYS
(TWO-LANE TWO WAY RURAL TRAFFIC)
(ROAD CLOSED TO THRU TRAFFIC)

STANDARD B.L.R. 22-7

Illinois Department of Transportation

PASSED January 1, 2012
Donell Lewis
ENGINEER OF LOCAL ROADS AND STREETS

APPROVED January 1, 2012
Scott Esdaile
ENGINEER OF DESIGN AND ENVIRONMENT

ISSUED 1-1-97

OFFSETS TO FACE OF RAIL		
Post	X ft (m)	Y ft (m)
①	37.22 (11.345)	4.0 (1.22)
②	31.09 (9.475)	2.79 (0.850)
③	24.92 (7.595)	1.79 (0.545)
④	20.79 (6.335)	1.25 (0.380)
⑤	16.64 (5.070)	0.80 (0.245)
⑥	12.49 (3.805)	0.45 (0.135)
⑦	6.25 (1.905)	0.11 (0.035)
⑧	0.00 (0.00)	0.00 (0.00)

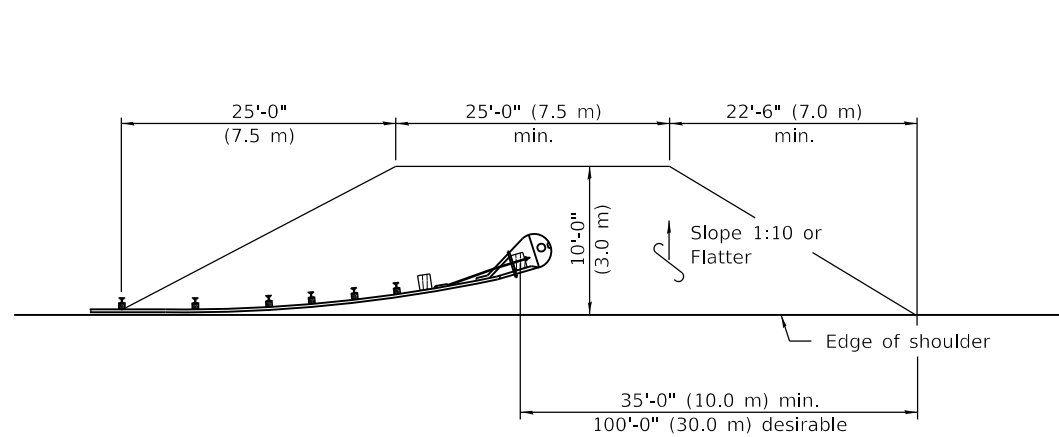

SHOULDER WIDENING TRANSITION

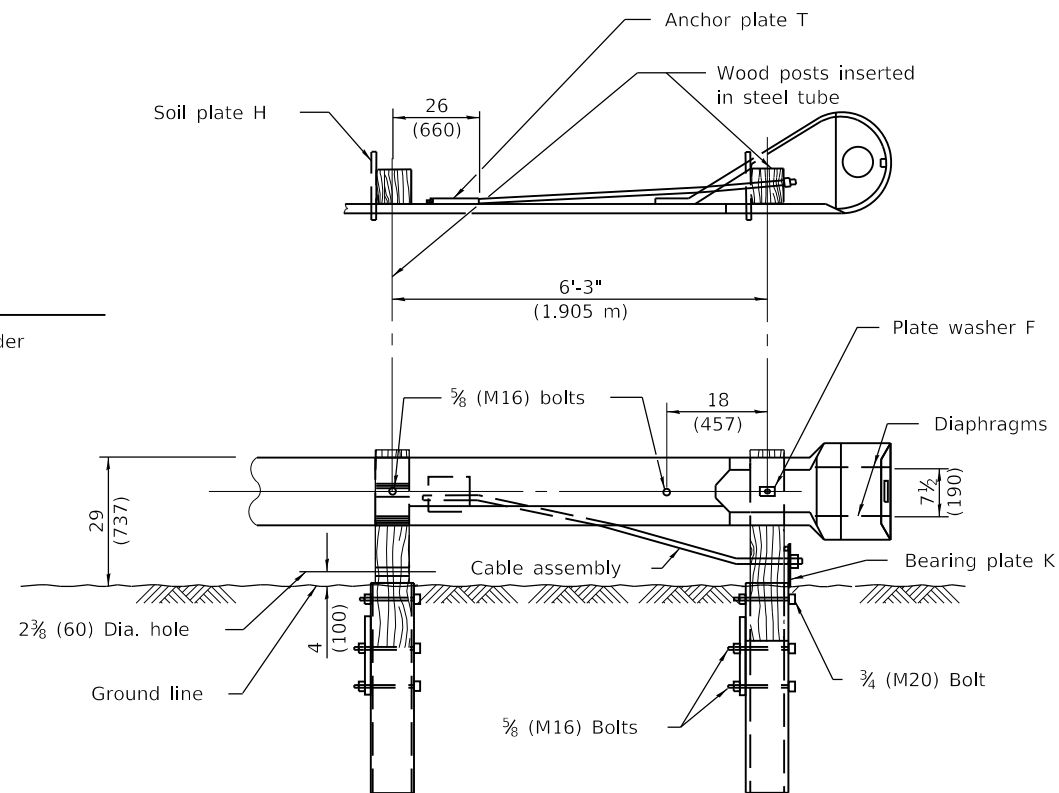

**WOOD BREAKAWAY POSTS
TUBULAR STEEL FOUNDATIONS**

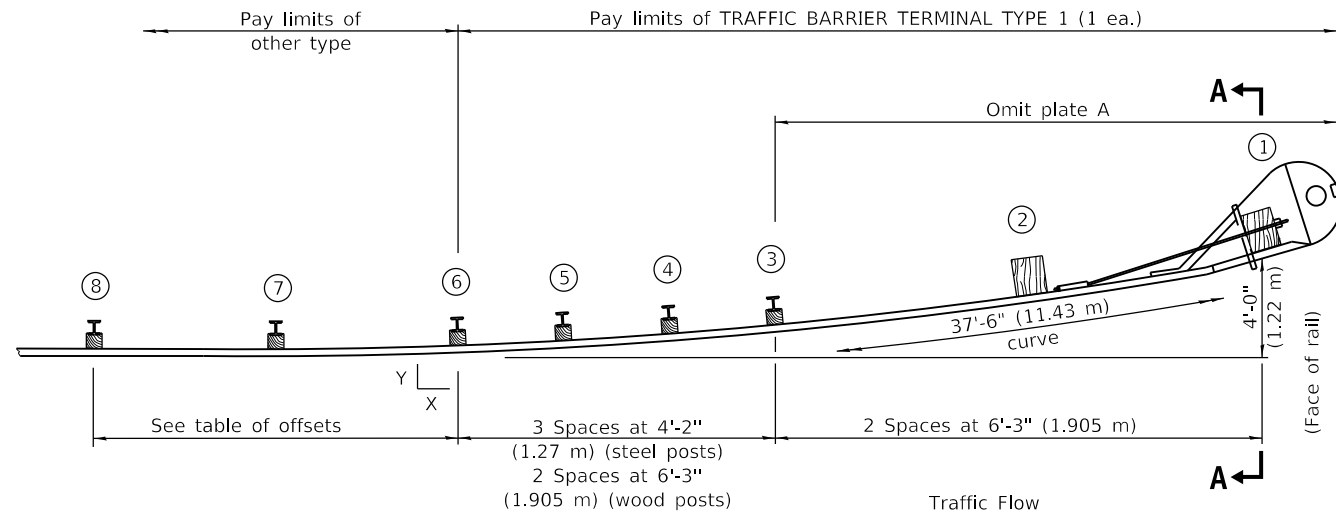

PLAN

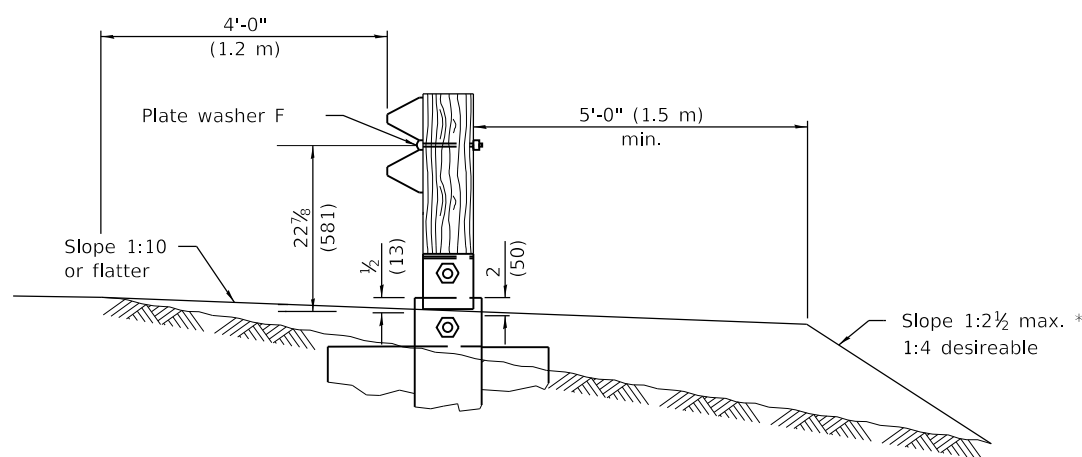

SECTION A-A

* If fill height exceeds 5'-0" (1.5 m) use 1:3 max.

GENERAL NOTES

See Standard B.L.R. 26 for details of guardrail not shown.

Posts at location 1 & 2 shall be wood breakaway posts. Posts other than 1 & 2 may be either standard wood posts or steel posts, at the option of the Contractor. If standard wood posts are used, one post shall be located midway between and in lieu of posts 4 & 5. The offset (Y) for this post shall be 12 (300).

A two-piece assembly may be substituted for the one piece nose shown above.

The bearing plate K shall be held in position by (2) two eightpenny nails driven into the post and bent over the top of the plate.

When this terminal is used with Standard 630001, the guardrail shall transition down to the height of the terminal prior to post 8.

All slope ratios are expressed as units of vertical displacement to units of horizontal displacement (V:H).

All dimensions are in inches (millimeters) unless otherwise shown.

DATE	REVISIONS
1-1-12	Revised barrier terminal height and wood breakaway post.
1-1-09	Switched units to English (metric).

**TRAFFIC BARRIER
TERMINAL TYPE 1**

(Sheet 1 of 2)

STANDARD B.L.R. 23-4

Illinois Department of Transportation

PASSED January 1, 2012
Donell Lewis
 ENGINEER OF LOCAL ROADS AND STREETS

APPROVED January 1, 2012
Scott Esch
 ENGINEER OF DESIGN AND ENVIRONMENT

ISSUED 1-1-08

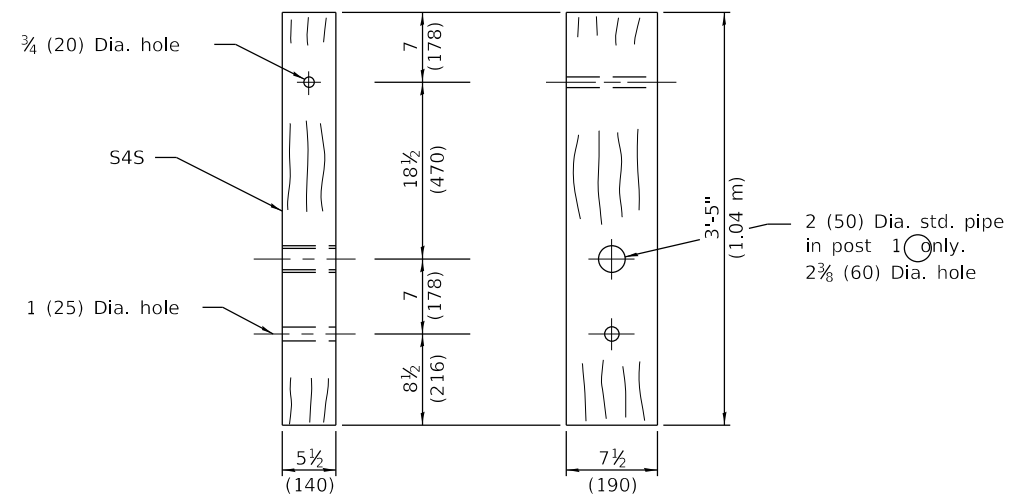

WOOD BREAKAWAY POST
(2 ea.)

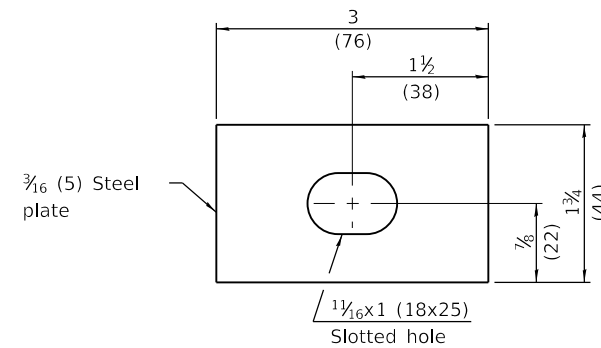
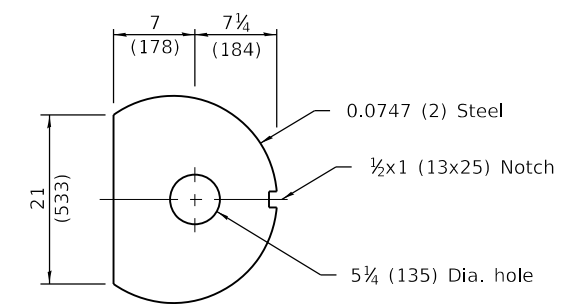
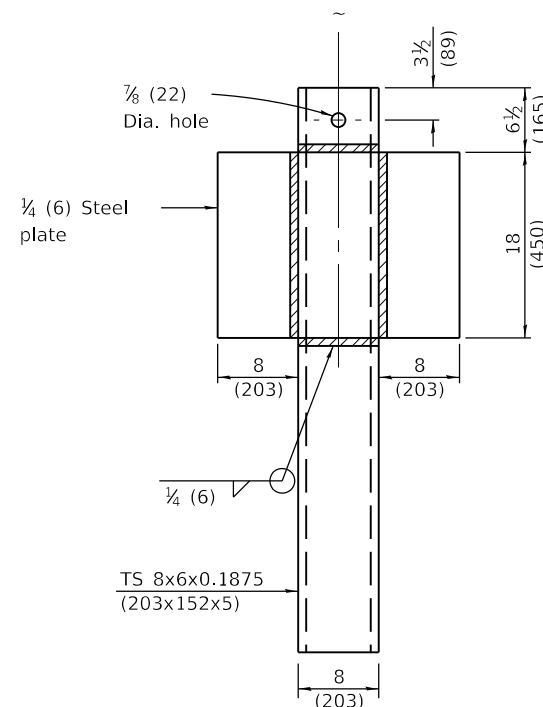

PLATE WASHER F
(1 ea.)



DIAPHRAGM
(2 ea.)



ALTERNATE SOIL PLATE CONNECTION

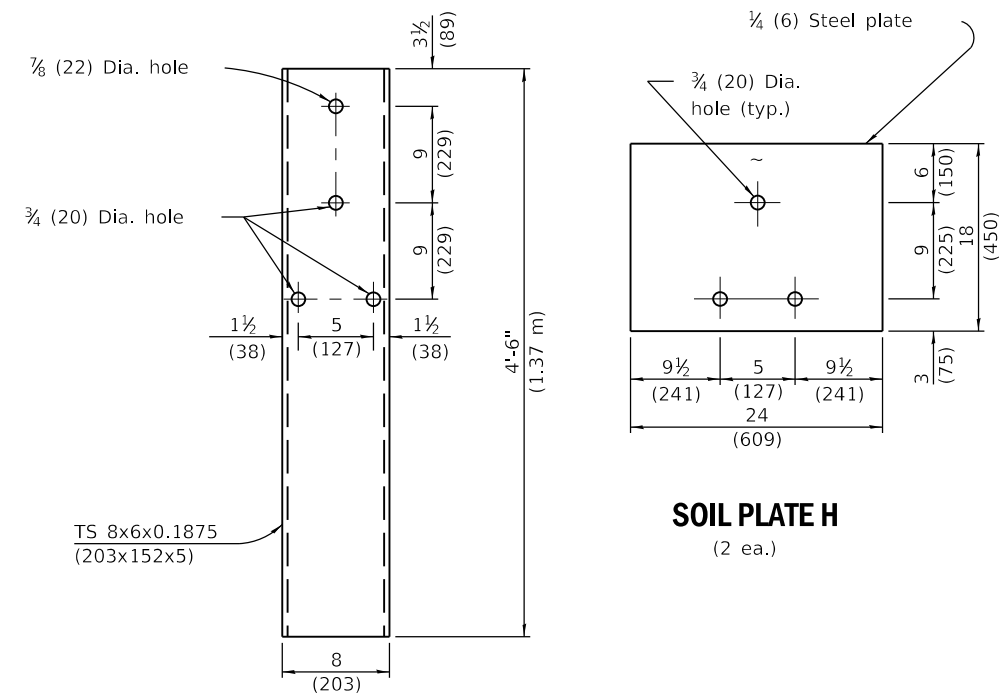

STEEL TUBE
(2 ea.)

SOIL PLATE H
(2 ea.)

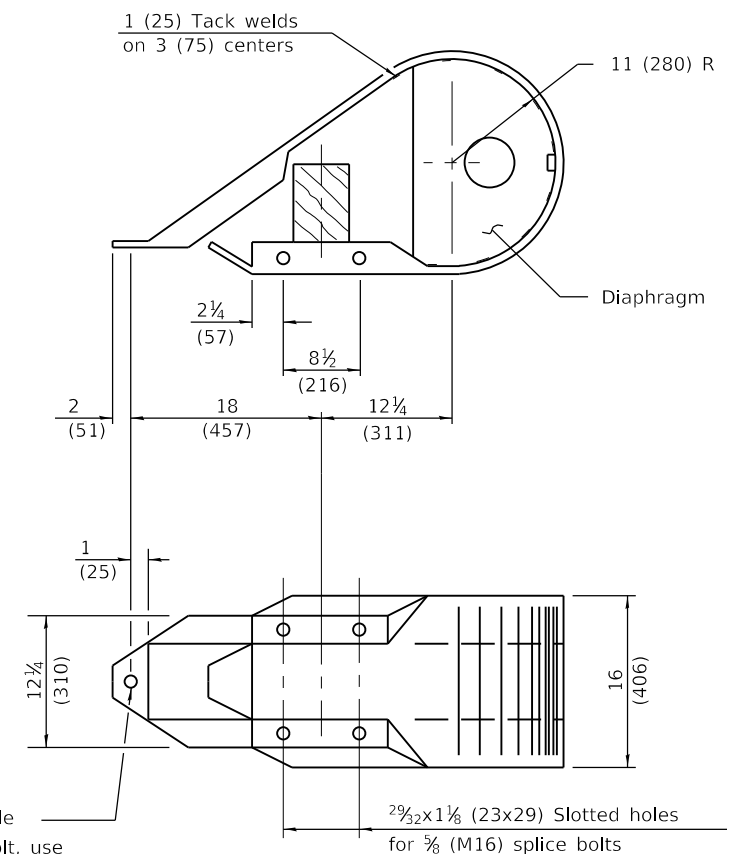

NOSE
(1 ea.)

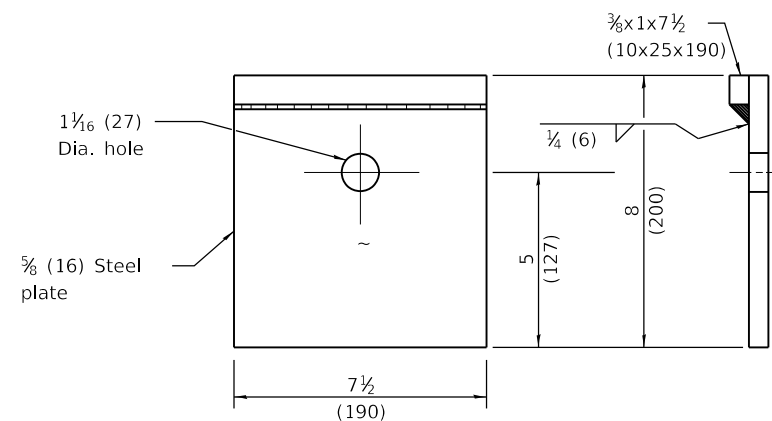

BEARING PLATE K
(1 ea.)

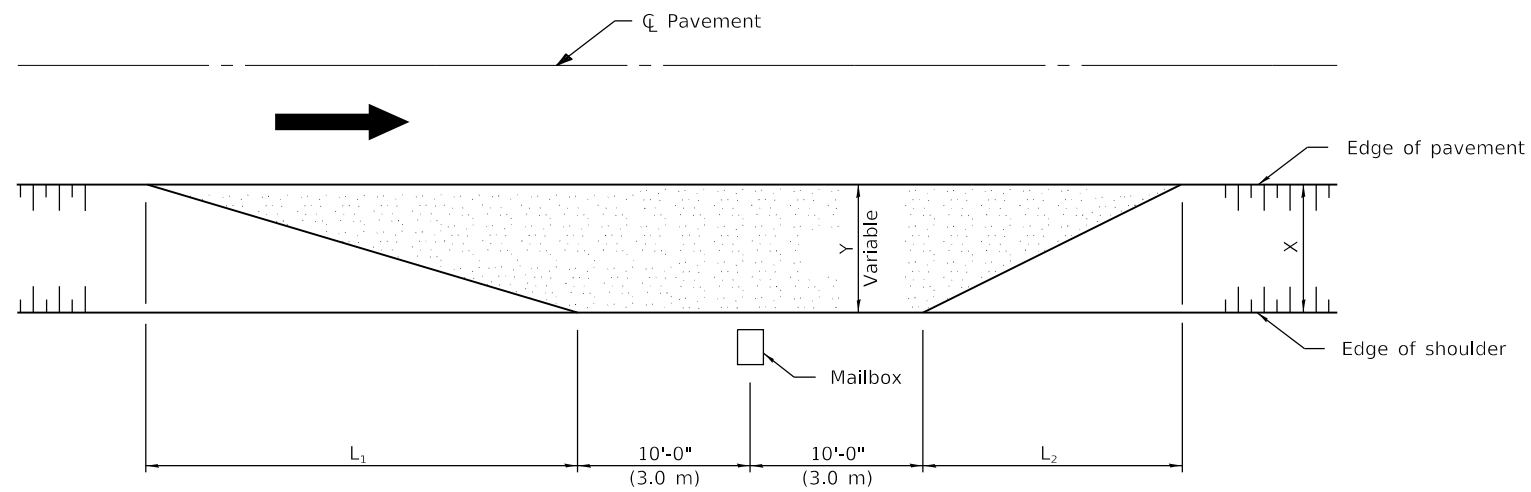

TYPICAL APPLICATION

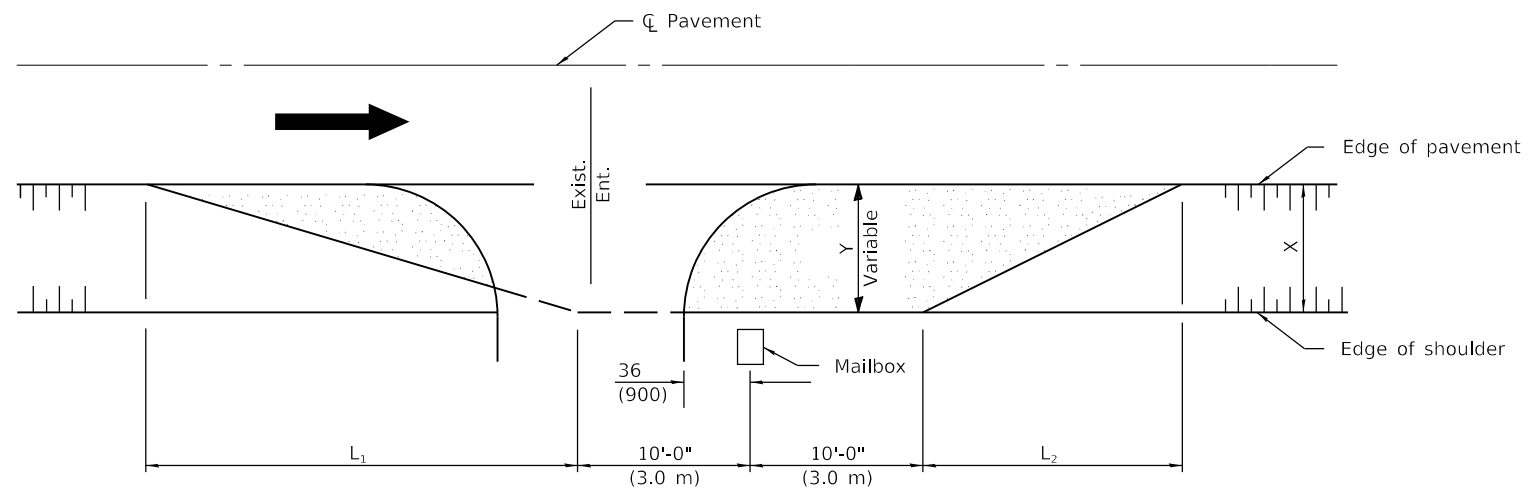

MAILBOX ON FAR SIDE OF ENTRANCE

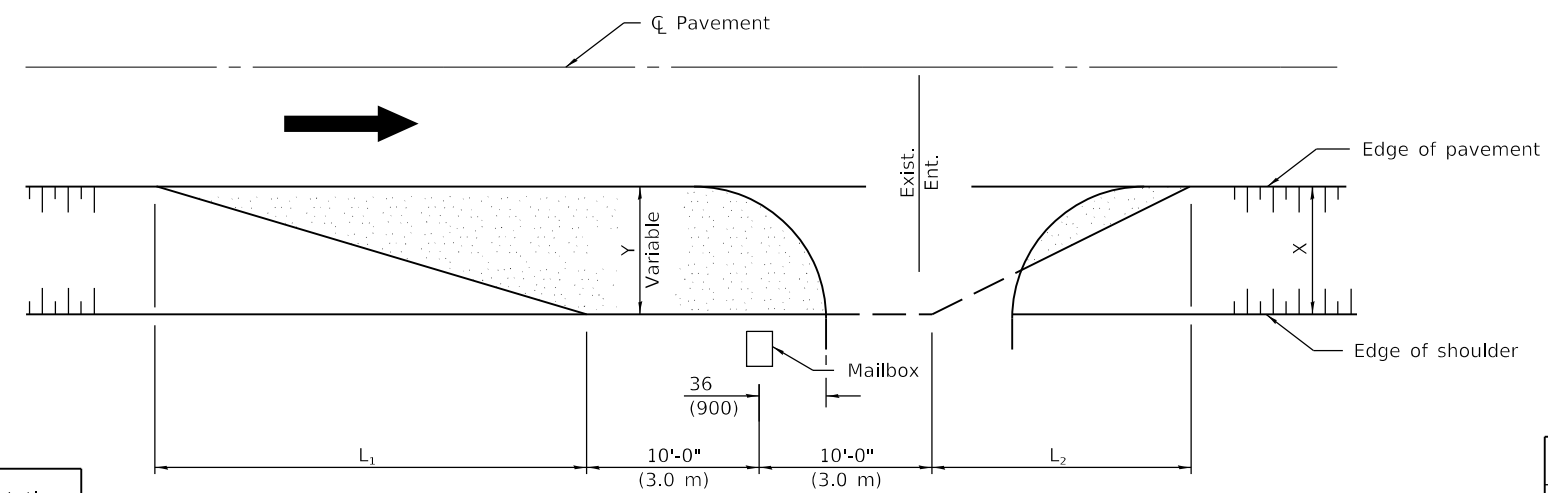

MAILBOX ON NEAR SIDE OF ENTRANCE

DIMENSIONS - ft. (m)						
Width of Shoulder (X)	12 (3.6)	10 (3.0)	8 (2.4)	6 (1.8)	5 (1.5)	4 (1.2)
Width of Turnout (Y)	8 (2.4)	8 (2.4)	6 (1.8)	4 (1.2)	4 (1.2)	4 (1.2)
L ₁	30 (9.0)	30 (9.0)	23 (6.9)	15 (4.5)	15 (4.5)	15 (4.5)
L ₂	20 (6.0)	20 (6.0)	15 (4.5)	10 (3.0)	10 (3.0)	10 (3.0)

Note:
Dimensions for Township and District Roads may vary from the above dimensions.

GENERAL NOTES

Mailboxes shall be mounted such that the face of the mailbox is 6 (150) to 12 (300) and the post a minimum of 24 (600) from the edge of the turnout surfacing.

All dimensions are in inches (millimeters) unless otherwise shown.

DATE	REVISIONS
1-1-09	Switched units to English (metric).
1-1-99	Add width of shoulder X.

MAILBOX TURNOUT FOR LOCAL ROADS

STANDARD B.L.R. 24-2

Illinois Department of Transportation
 PASSED January 1, 2009
Charles J. Ringwood
 ENGINEER OF LOCAL ROADS AND STREETS
 APPROVED January 1, 2009
Ken E. Han
 ENGINEER OF DESIGN AND ENVIRONMENT

ISSUED 1-1-97

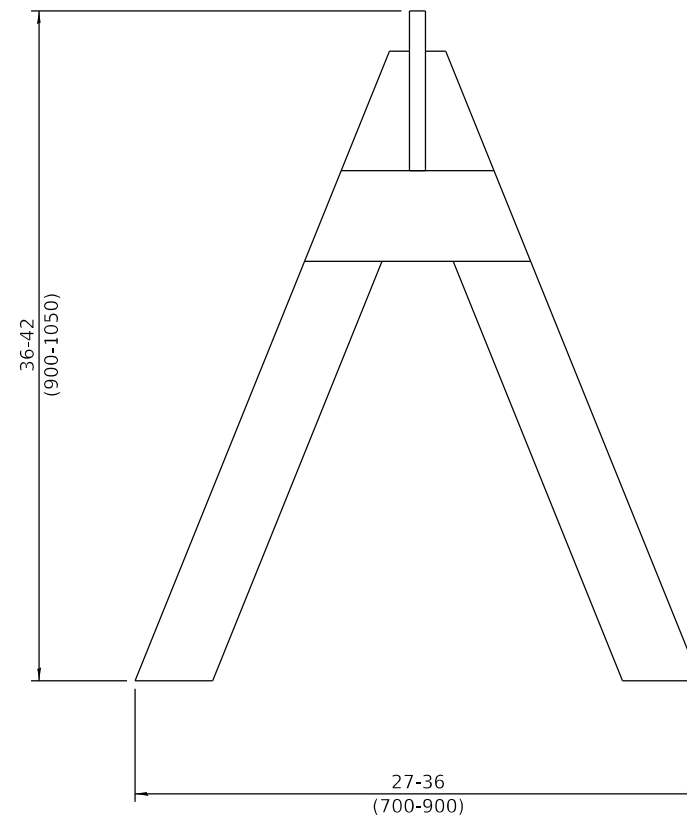
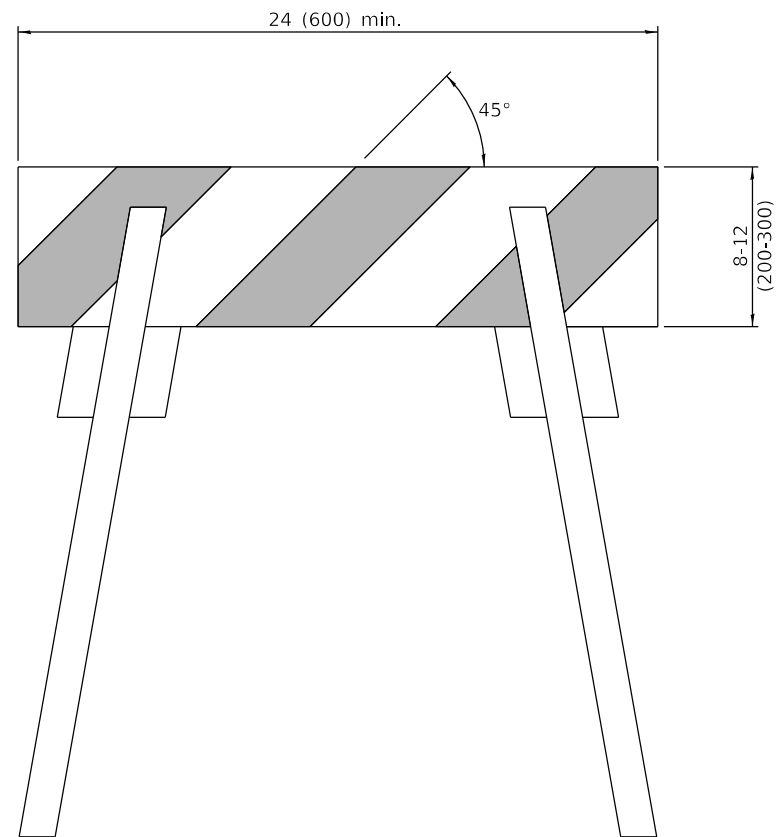

All dimensions are in inches (millimeters)
unless otherwise shown.

DATE	REVISIONS
1-1-09	Switched units to English (metric).
1-1-03	New standard from 702001-02

TYPE 1A BARRICADE FOR NON-NHS ROUTES

STANDARD B.L.R. 25-1

 Illinois Department of Transportation
 PASSED January 1, 2009
Charles J. Longwell
 ENGINEER OF LOCAL ROADS AND STREETS
 APPROVED January 1, 2009
Ken E. Han
 ENGINEER OF DESIGN AND ENVIRONMENT

ISSUED 1-1-03

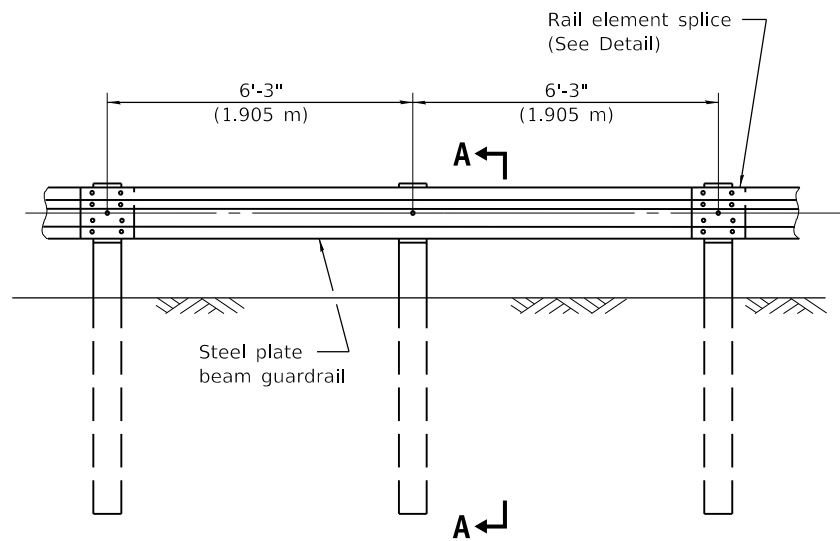

ELEVATION

TYPE A

6'-3" (1.905 m) Typical post spacing

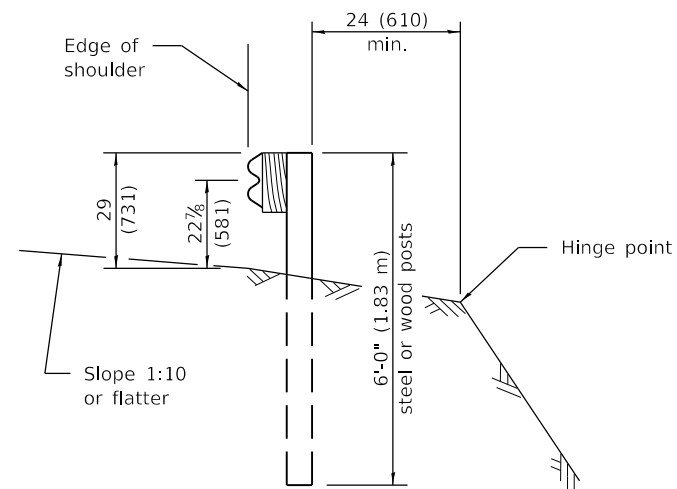

SECTION A-A

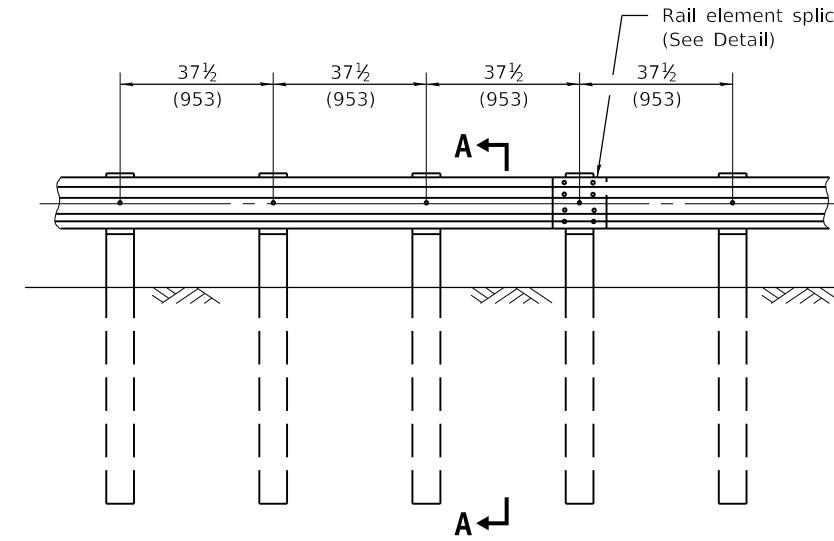

ELEVATION

TYPE B

37 1/2 (953) Closed post spacing

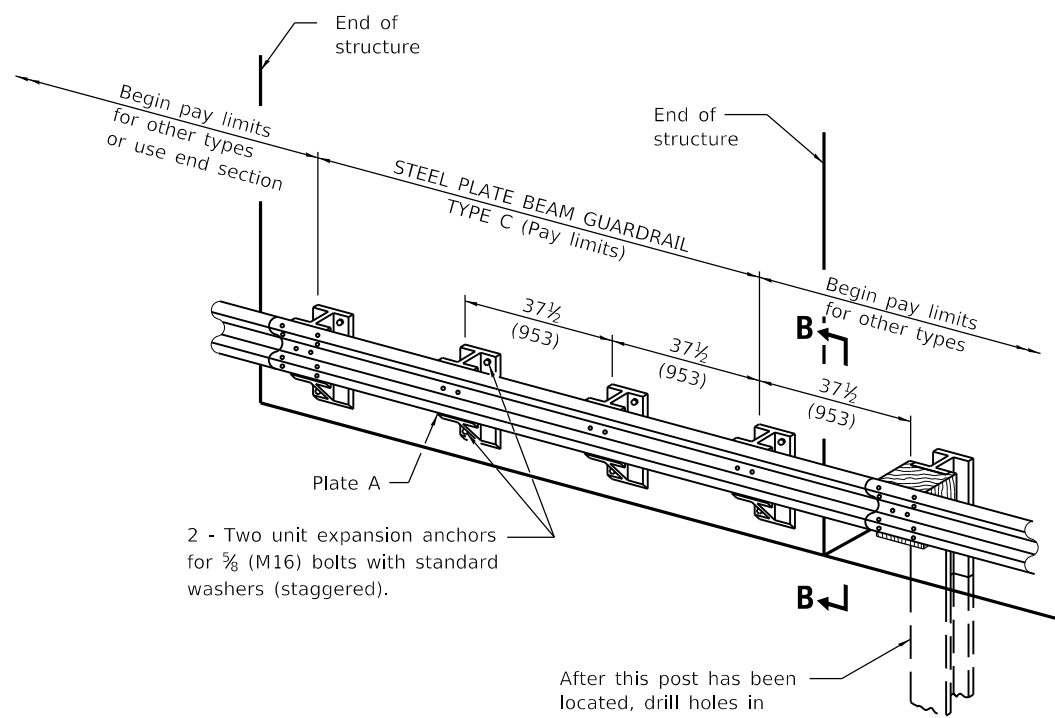

TYPE C

37 1/2 (953) Block-out spacing

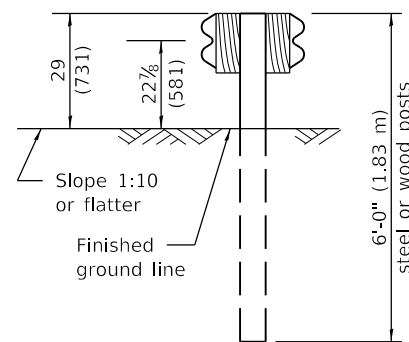

SECTION C-C

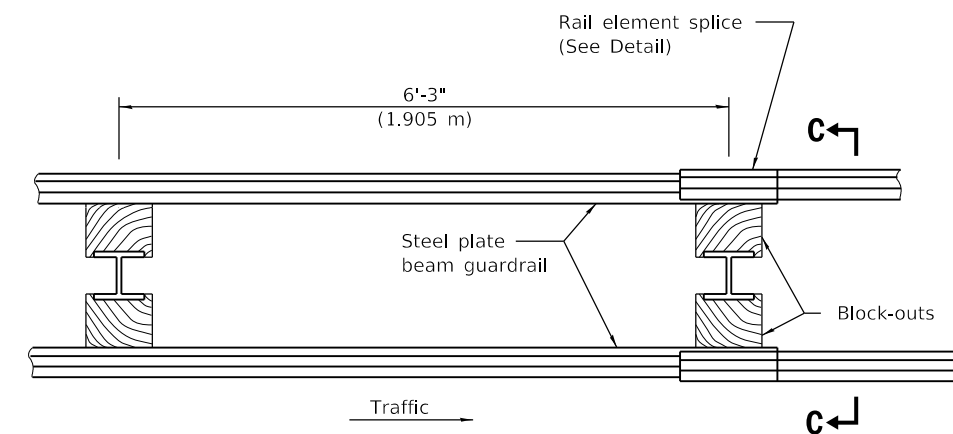

PLAN

TYPE D

Double steel plate beam guardrail
6'-3" (1.905 m) typical post spacing

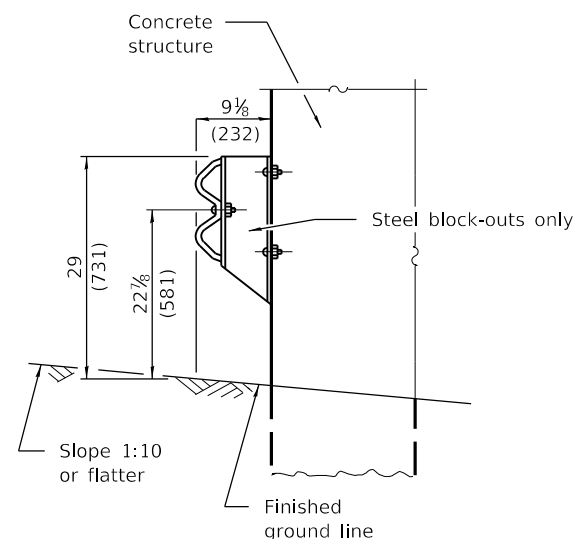

SECTION B-B

GENERAL NOTES

All slope ratios are expressed as units of vertical displacement to units of horizontal displacement (V:H).

All dimensions are in inches (millimeters) unless otherwise shown.

DATE	REVISIONS
1-1-12	Revised guardrail height.
	Modified table on sh. 4.
	Renamed standard.
1-1-10	Changed post length
	from 6'-9" to 6'-0".
	Modified table on sh. 4.

STEEL PLATE BEAM GUARDRAIL
29" (731mm) HEIGHT

(Sheet 1 of 4)

STANDARD B.L.R. 26-3

Illinois Department of Transportation

PASSED January 1, 2012

ENGINEER OF LOCAL ROADS AND STREETS

APPROVED January 1, 2012

ENGINEER OF DESIGN AND ENVIRONMENT

ISSUED 1-1-08

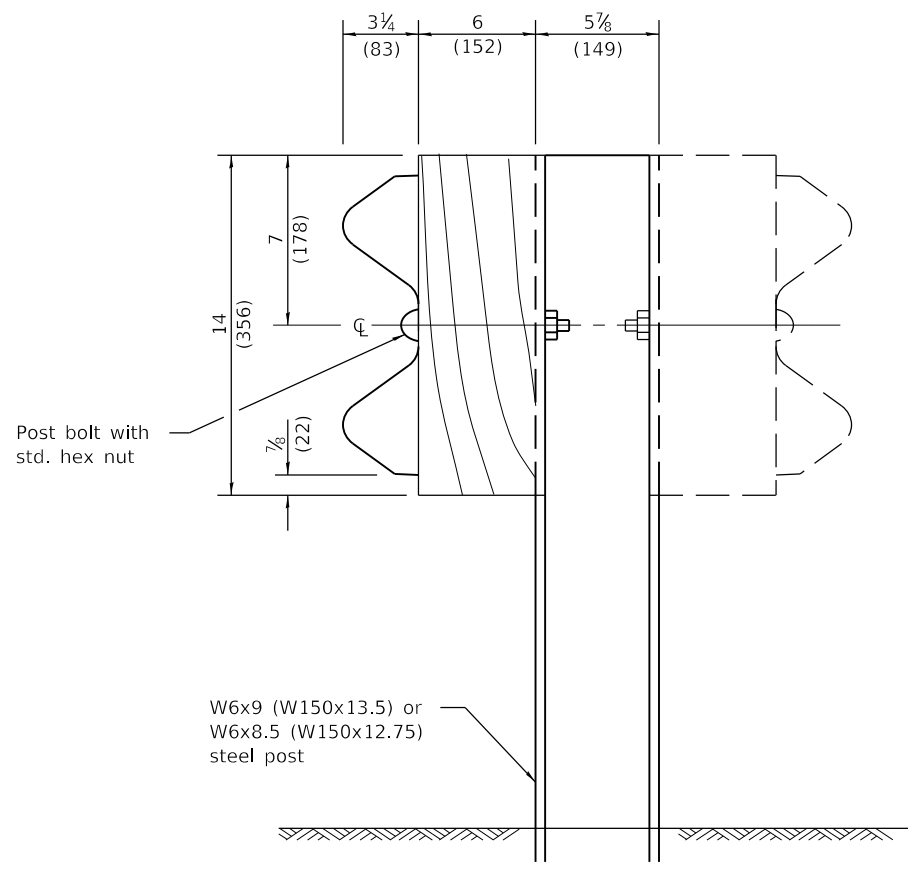

STEEL POST CONSTRUCTION

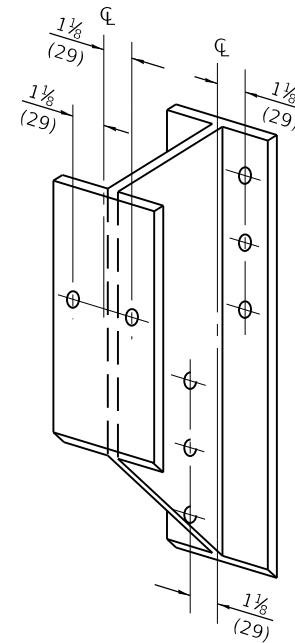

STEEL BLOCK-OUT DETAIL

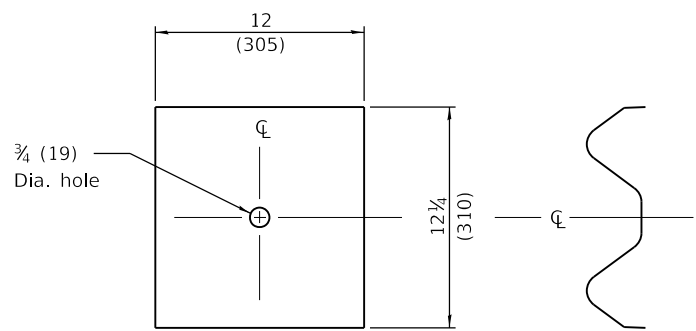

NOTE
Plate A shall be placed between rail element and block-out at non-splice mounting points only when steel block-outs are used.

PLATE A

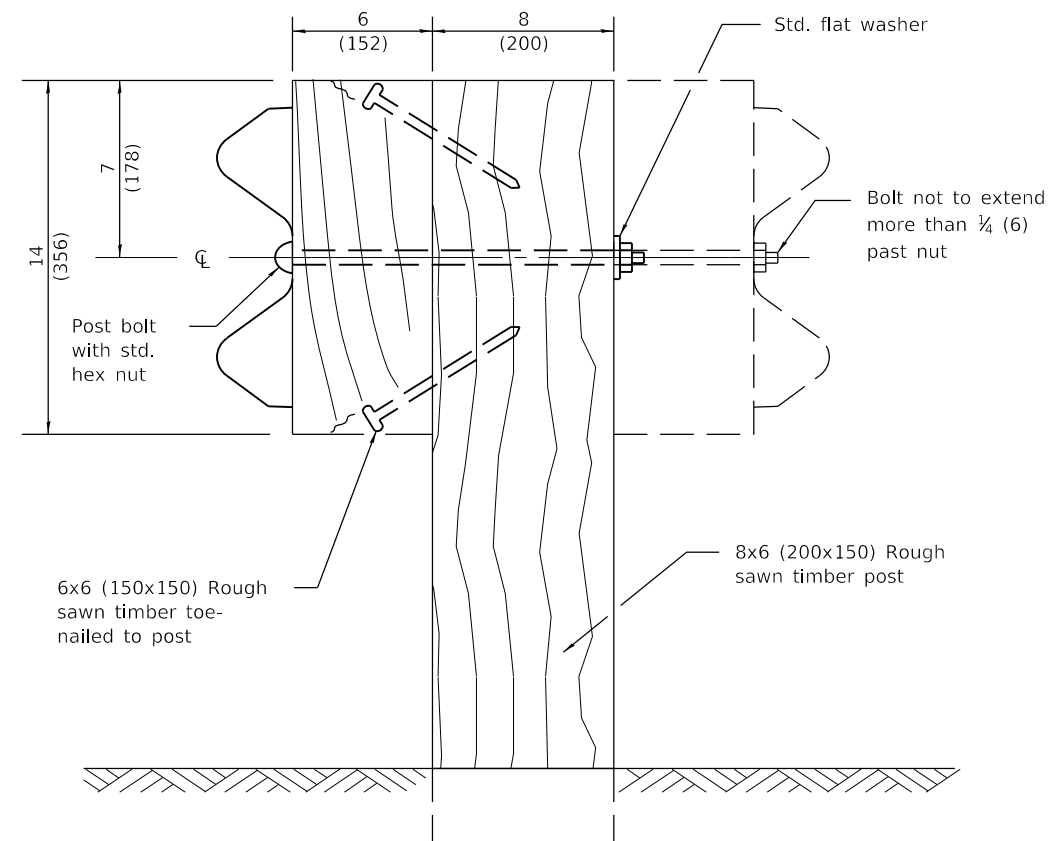

WOOD POST CONSTRUCTION

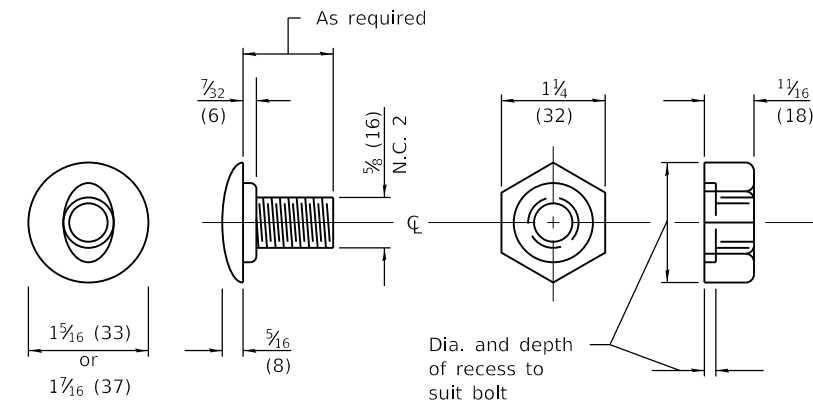

POST OR SPLICE BOLT & NUT

Illinois Department of Transportation

PASSED January 1, 2012

Donell Lewis
ENGINEER OF LOCAL ROADS AND STREETS

APPROVED January 1, 2012

Scott Esdaile
ENGINEER OF DESIGN AND ENVIRONMENT

ISSUED 1-1-08

STEEL PLATE BEAM GUARDRAIL
29" (731mm) HEIGHT
(Sheet 2 of 4)

STANDARD B.L.R. 26-3

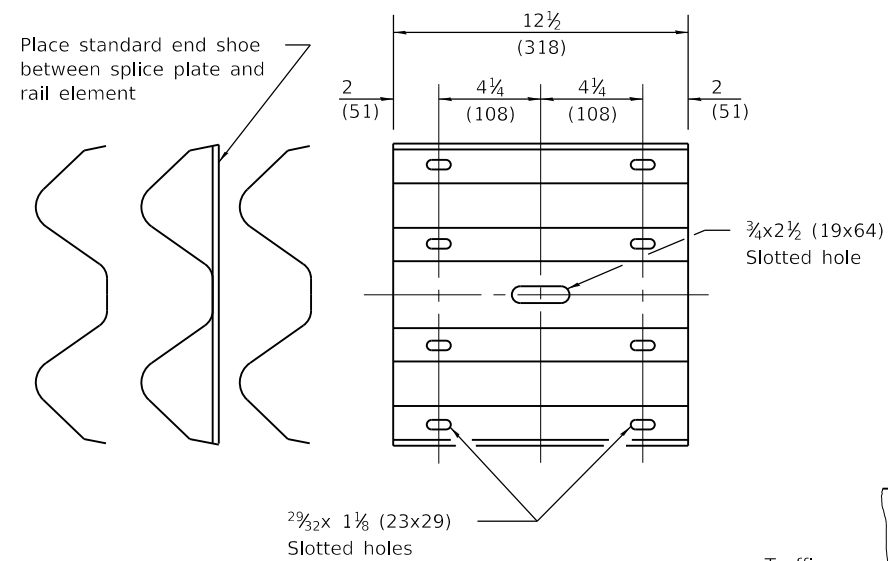

SPLICE PLATE

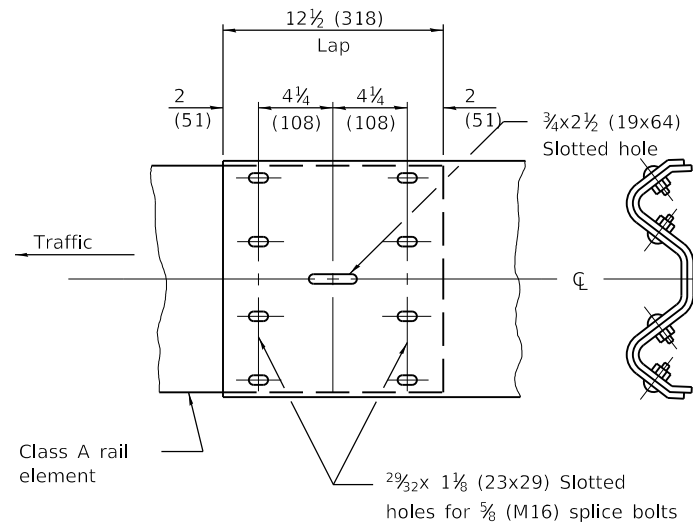

RAIL ELEMENT SPLICE

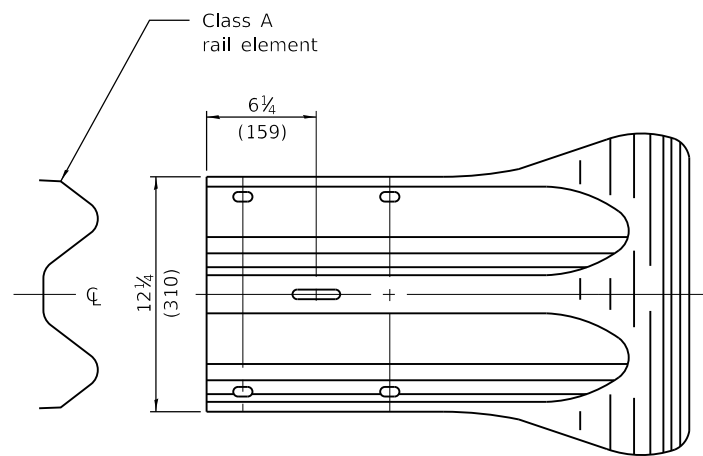
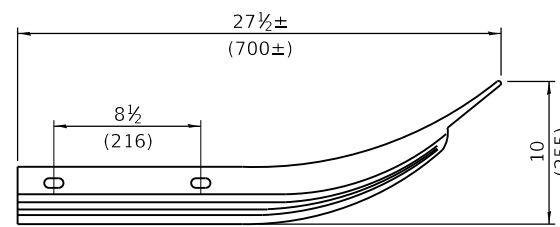

END SECTION

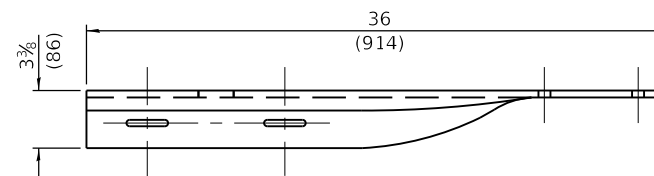
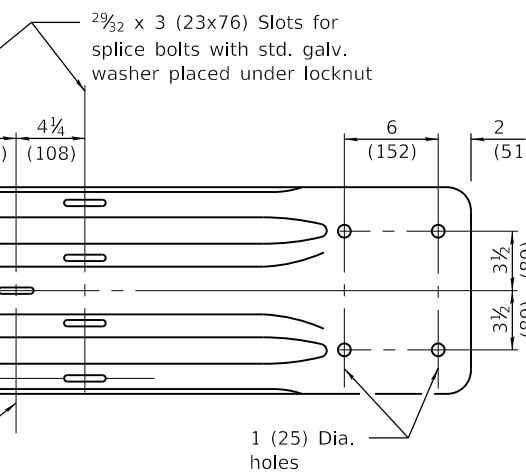

NOTE
When end shoe is attached to a bridge parapet which has an expansion joint, the bolts shall be provided with a locknut or double nut and shall be tightened only to a point that will allow guardrail movement.

The standard end shoe shall be attached to the concrete with pre-drilled or self-drilling anchor bolts. The anchor cone shall be set flush with the surface of the concrete.

Externally threaded studs protruding from the surface of the concrete will not be permitted.

END SHOE

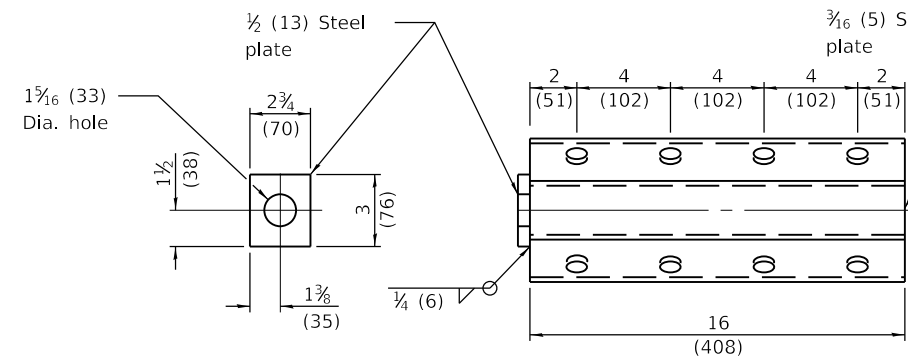

NOTE
Anchor plate T shall be used to attach cable assembly to guardrail when required on traffic barrier terminals.

ANCHOR PLATE T DETAILS

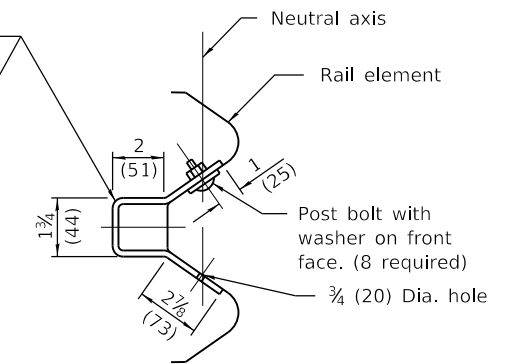

ALTERNATE END SHOE

**STEEL PLATE BEAM GUARDRAIL
29" (731mm) HEIGHT**

(Sheet 3 of 4)

STANDARD B.L.R. 26-3

Illinois Department of Transportation

PASSED January 1, 2012

ENGINEER OF LOCAL ROADS AND STREETS

APPROVED January 1, 2012

ENGINEER OF DESIGN AND ENVIRONMENT

ISSUED 1-1-08

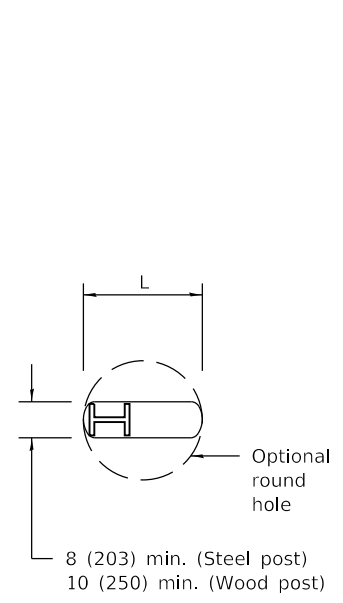

PLAN

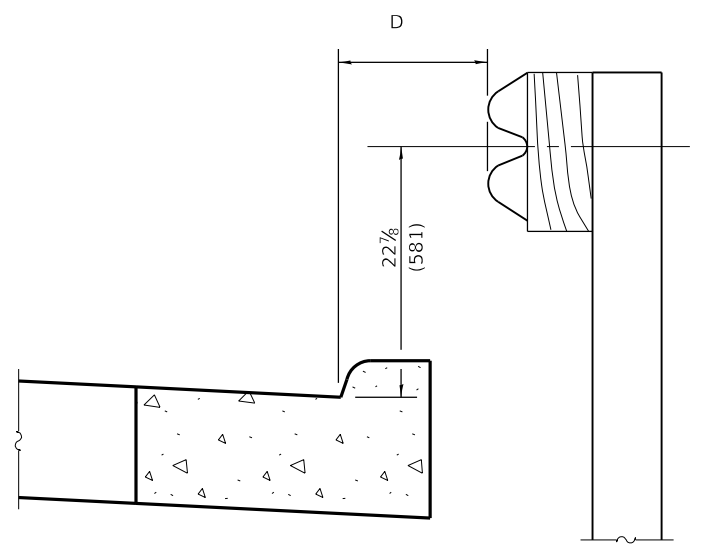

Note:
If it is necessary for D to be more than 12 (300) and less than 10'-0" (3.0 m) Type M-2 (M-5) curb and gutter (Std. 606001) shall be used in front of and in advance of the guardrail.

**GUARDRAIL PLACED BEHIND CURB
(D = 0 desirable to 12 (300) maximum)**

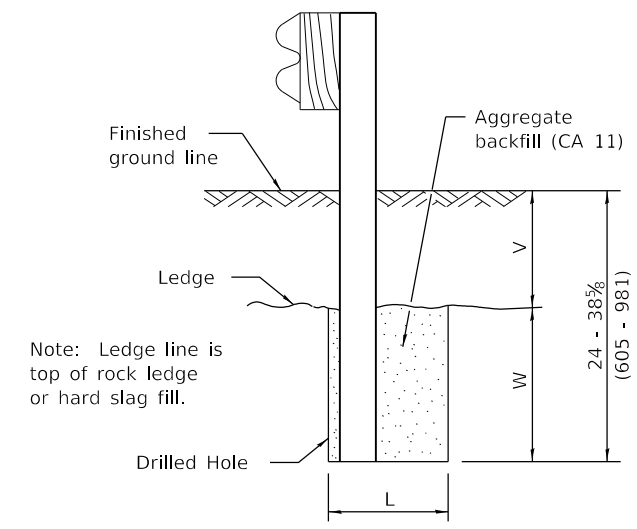

ELEVATION

FOOTING FOR POST WHEN IMPERVIOUS MATERIAL IS ENCOUNTERED

V	W	L	
		Steel Post	Wood Post
0 - 16 1/8 (0 - 410)	24 (610)	21 (530)	23 (580)
>16 1/8 - 28 1/8 (>410 - 714)	12 (305)	8 (203)	10 (250)
>28 1/8 - 38 5/8 (>714 - 981)	12 - 0 (305 - 0)	8 (203)	10 (250)

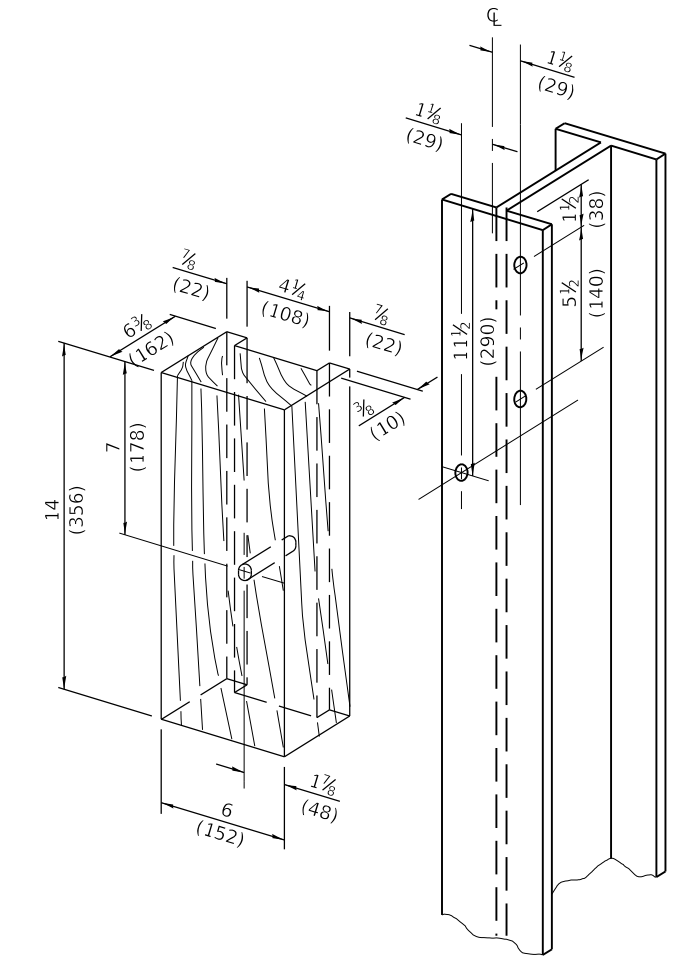

**WOOD BLOCK-OUT AND
STEEL POST DETAILS**

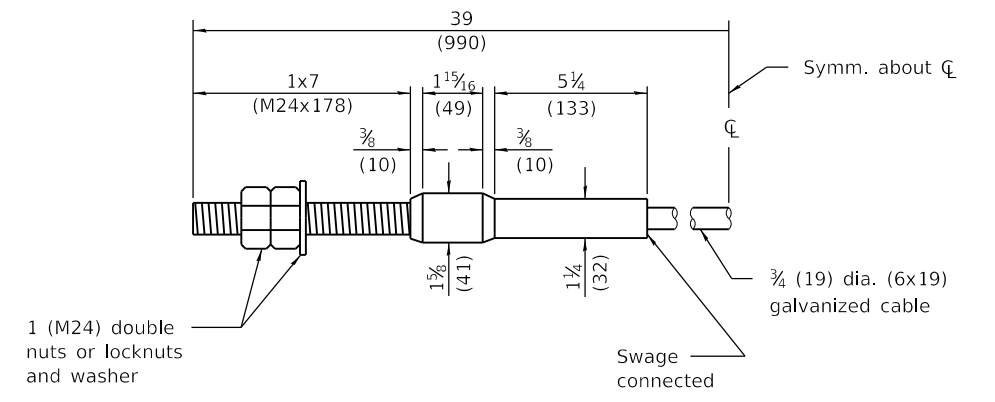

CABLE ASSEMBLY

(40,000 lbs. (18,100 kg) min. breaking strength)
Tighten to taut tension.

Illinois Department of Transportation

PASSED January 1, 2012

ENGINEER OF LOCAL ROADS AND STREETS

APPROVED January 1, 2012

ENGINEER OF DESIGN AND ENVIRONMENT

ISSUED 1-1-08

STEEL PLATE BEAM GUARDRAIL

29" (731mm) HEIGHT

(Sheet 4 of 4)

STANDARD B.L.R. 26-3

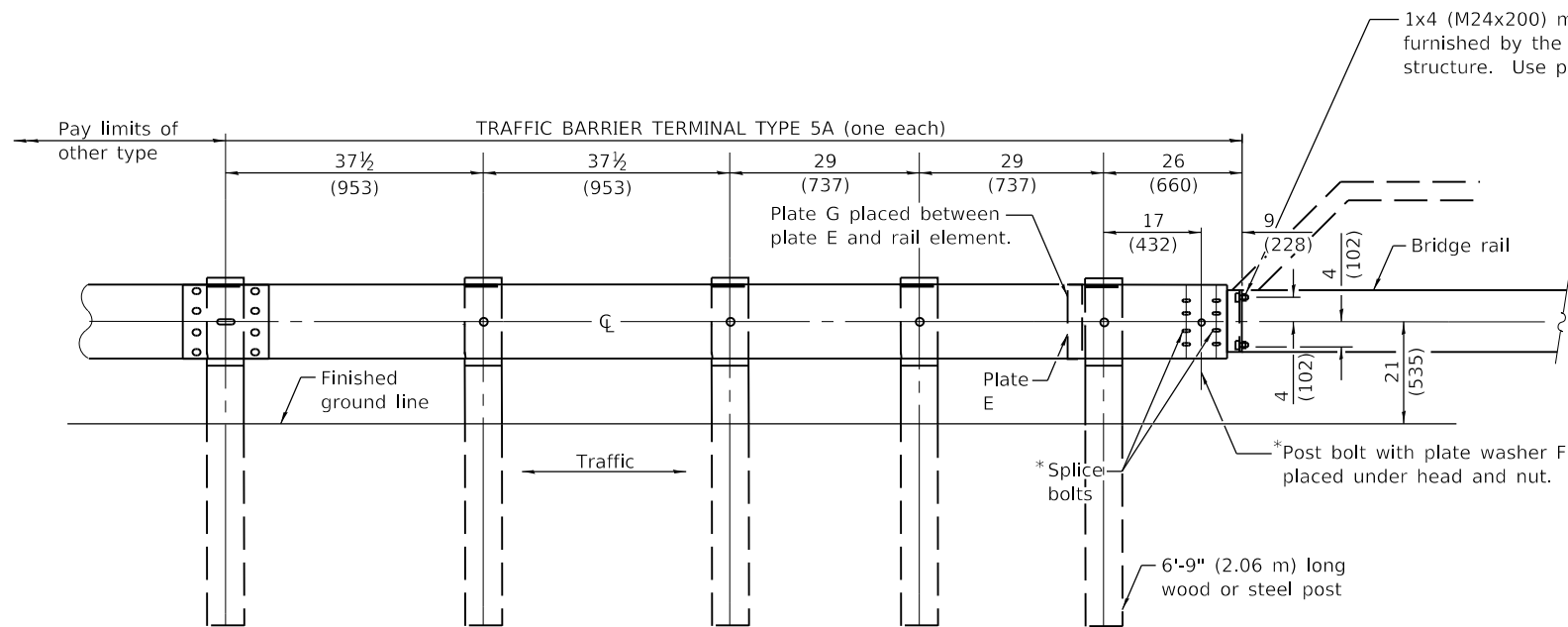

TYPE 5A - STEEL BRIDGE RAIL

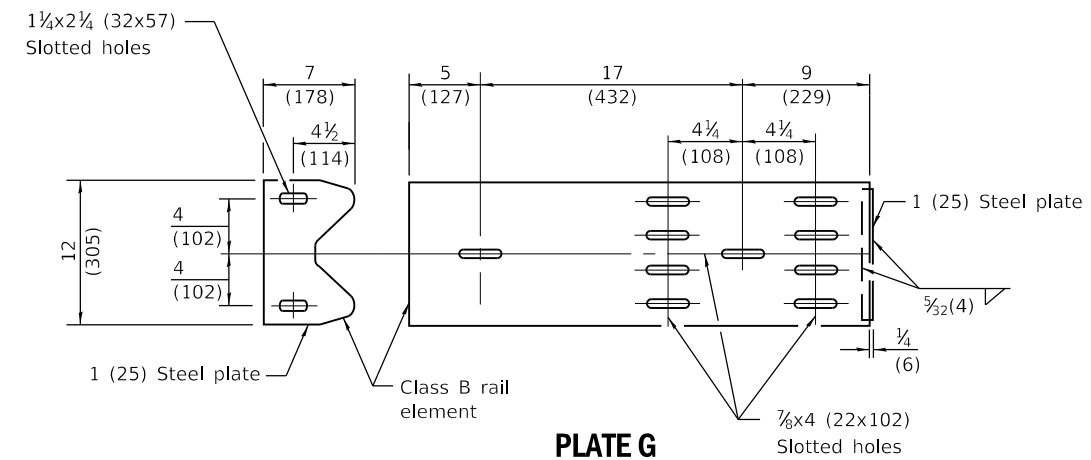

PLATE G

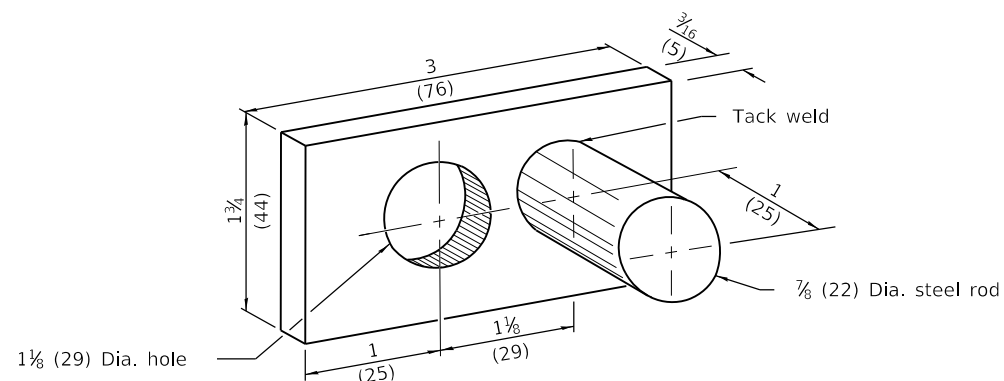
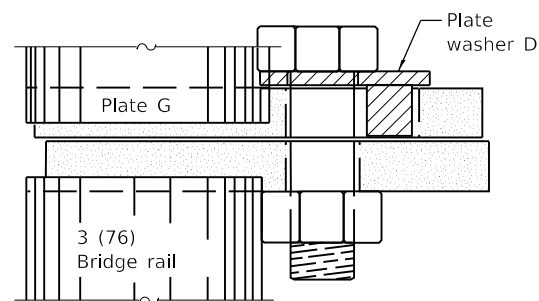

PLATE WASHER D



PLACEMENT OF PLATE WASHER D

(PLAN)

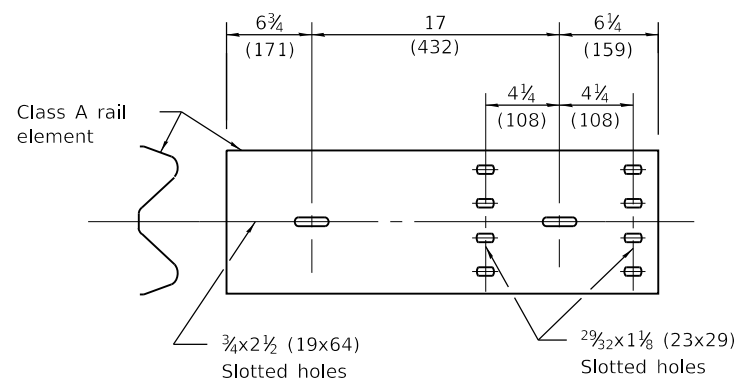
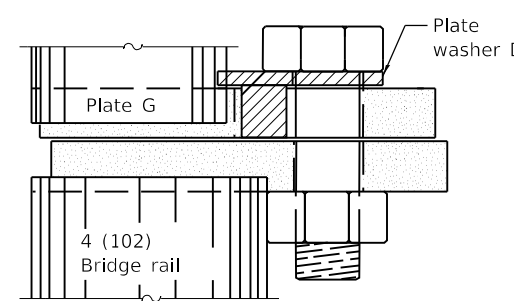

PLATE E

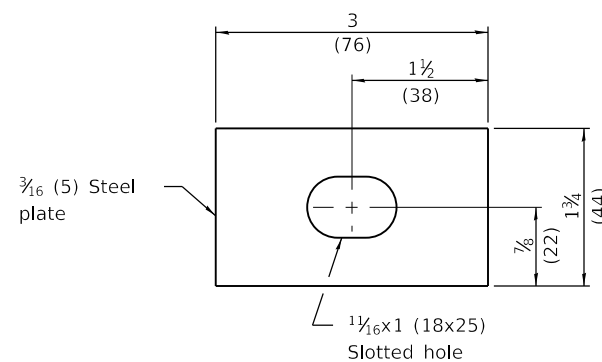

PLATE WASHER F

GENERAL NOTES

See Standard B.L.R. 26 for details of guardrail not shown.

Install plate washer D so the 1 (25) projection fills the remainder of the slotted holes in the 1 (25) end plate on plate G after the 1 (M24) dia. bolts are in place.

When an expansion joint exists below the connector, bolts shall be provided with a locknut or double nuts and shall be tightened only to a point that will allow plate G to be free to move.

The face of the guardrail shall be installed flush with the face of the bridge rail.

When this terminal is used with Standard 630001, the guardrail shall transition down to the height of the terminal.

All dimensions are in inches (millimeters) unless otherwise shown.

DATE	REVISIONS
1-1-09	Switched units to English (metric).
1-1-08	New Standard. Was part of Std. 631026 prior to January 1, 2007.

TRAFFIC BARRIER TERMINAL TYPE 5A

STANDARD B.L.R. 27-1

Illinois Department of Transportation

PASSED January 1, 2009
Charles J. Longwell
 ENGINEER OF LOCAL ROADS AND STREETS

APPROVED January 1, 2009
Ken E. Han
 ENGINEER OF DESIGN AND ENVIRONMENT

ISSUED 1-1-08

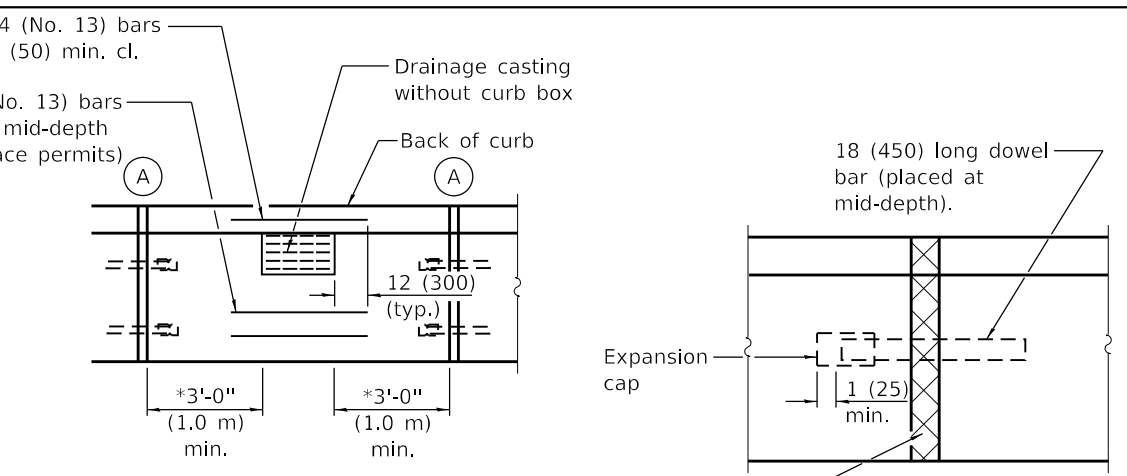
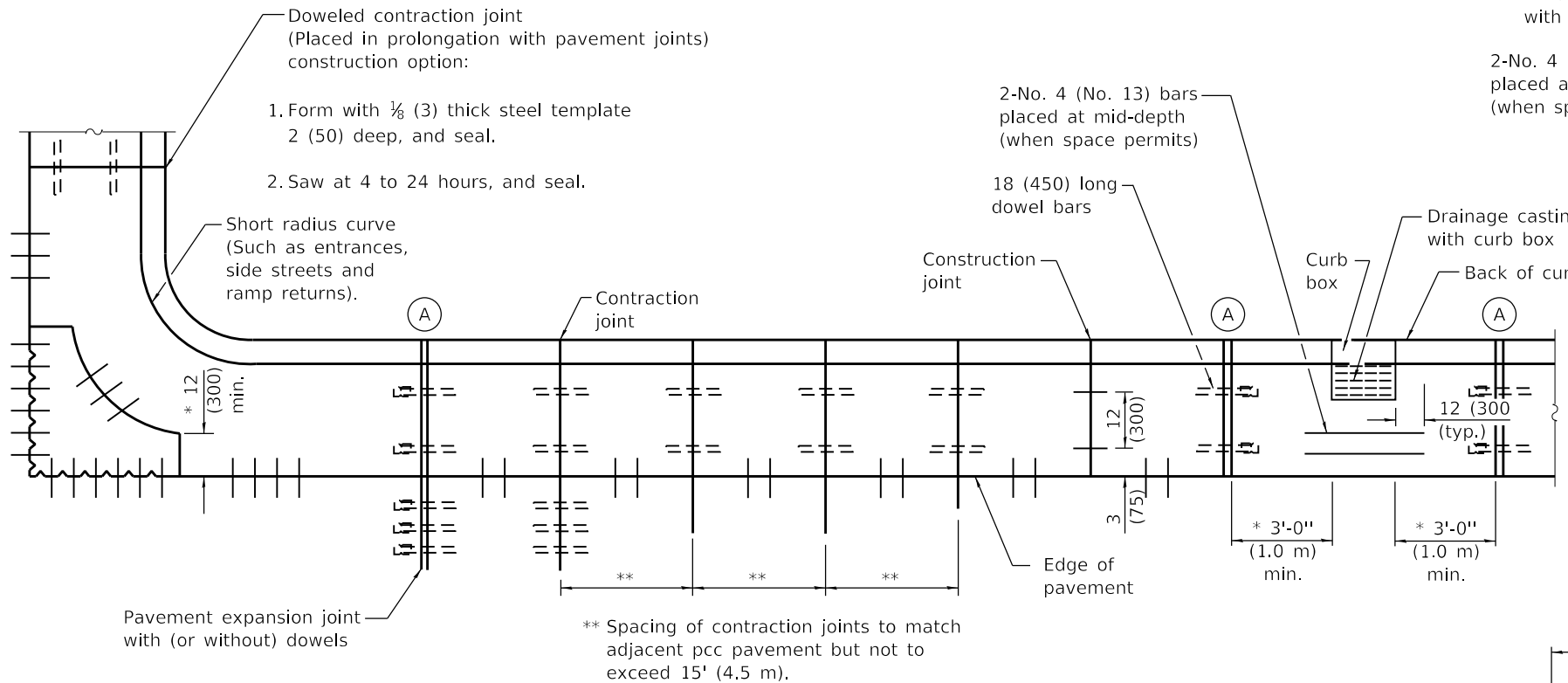

* This dimension shall be adjusted to align with joint on the adjacent pavement

Full depth & width 1 (25) - thick (min.) preformed expansion joint filler.

PLAN
ADJACENT TO PCC PAVEMENT OR PCC BASE COURSE

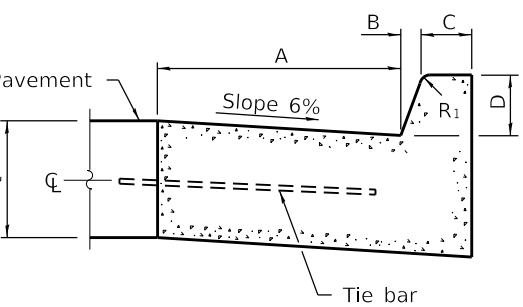

BARRIER CURB

TABLE OF DIMENSIONS BARRIER CURB					
TYPE	A	B	C	D	R ₁
B-6.06 *	6	1	6	6	1
(B-15.15)	(150)	(25)	(150)	(150)	(25)
B-6.12	12	1	6	6	1
(B-15.3)	(300)	(25)	(150)	(150)	(25)
B-6.18	18	1	6	6	1
(B-15.45)	(450)	(25)	(150)	(150)	(25)
B-6.24	24	1	6	6	1
(B-15.60)	(600)	(25)	(150)	(150)	(25)
B-9.12	12	2	5	9	1
(B-22.30)	(300)	(50)	(125)	(225)	(25)
B-9.18	18	2	5	9	1
(B-22.45)	(450)	(50)	(125)	(225)	(25)
B-9.24	24	2	5	9	1
(B-22.60)	(600)	(50)	(125)	(225)	(25)

* For corner islands only.

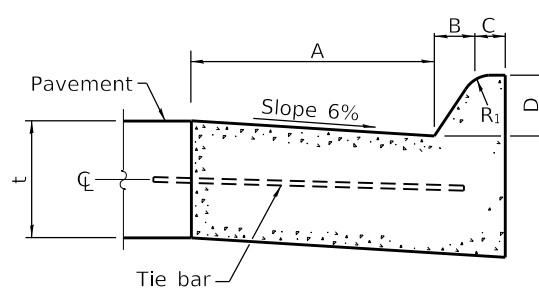

MOUNTABLE CURB

TABLE OF DIMENSIONS MOUNTABLE CURB						
TYPE	A	B	C	D	R ₁	R ₂
M-2.06	6	2	4	2	3	2
(M-5.15)	(150)	(50)	(100)	(50)	(75)	(50)
M-2.12	12	2	4	2	3	2
(M-5.30)	(300)	(50)	(100)	(50)	(75)	(50)
M-4.06	6	4	3	4	3	NA
(M-10.15)	(150)	(100)	(75)	(100)	(75)	(50)
M-4.12	12	4	3	4	3	NA
(M-10.30)	(300)	(100)	(75)	(100)	(75)	(50)
M-4.18	18	4	3	4	3	NA
(M-10.45)	(450)	(100)	(75)	(100)	(75)	(50)
M-4.24	24	4	3	4	3	NA
(M-10.60)	(600)	(100)	(75)	(100)	(75)	(50)
M-6.06	6	6	2	6	2	NA
(M-15.15)	(150)	(150)	(50)	(150)	(50)	(50)
M-6.12	12	6	2	6	2	NA
(M-15.30)	(300)	(150)	(50)	(150)	(50)	(50)
M-6.18	18	6	2	6	2	NA
(M-15.45)	(450)	(150)	(50)	(150)	(50)	(50)
M-6.24	24	6	2	6	2	NA
(M-15.60)	(600)	(150)	(50)	(150)	(50)	(50)

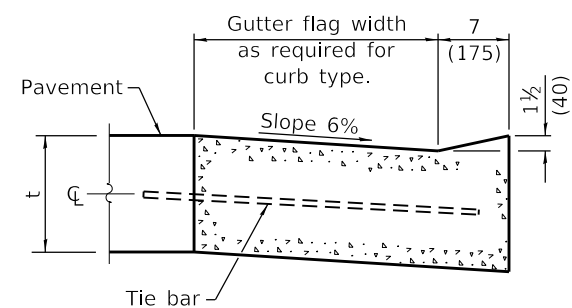

DEPRESSED CURB (TYPICAL)

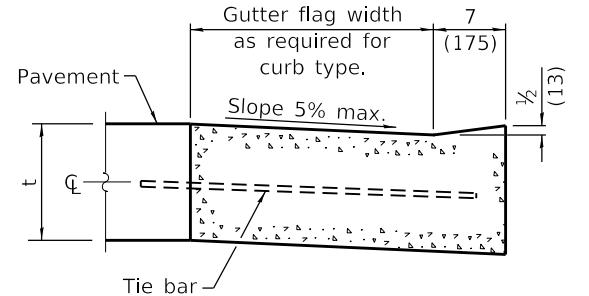

DEPRESSED CURB ADJACENT TO CURB RAMP ACCESSIBLE TO THE DISABLED

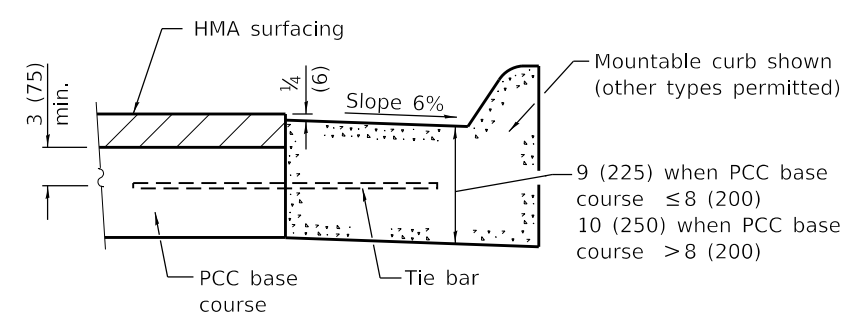

ADJACENT TO PCC BASE COURSE WITH HMA SURFACING

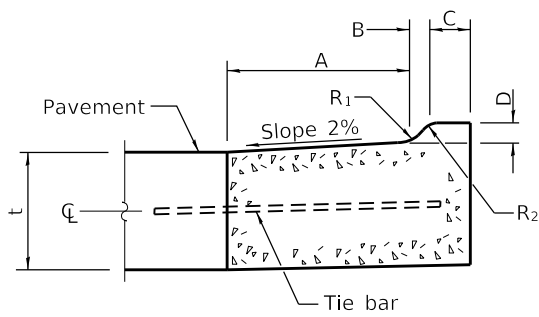

M-2.06 (M-5.15) and M-2.12 (M-5.30)

DOWEL BAR TABLE

PAVEMENT THICKNESS	DOWEL BAR DIAMETER
10 (250) and greater	1 1/2 (38)
8.01 (201) to 9.99 (249)	1 1/4 (32)
8 (200) and less	1 (25)

DATE	REVISIONS
1-1-22	Revised contraction joint spacing adjacent to pcc pavt. and DOWEL BAR TABLE.
1-1-18	New standard.

GENERAL NOTES

The bottom slope of combination curb and gutter constructed adjacent to pcc pavement shall be the same slope as the subbase or 6% when subbase is omitted.

t = Pavement thickness.

Longitudinal joint tie bars shall be No. 5 (No. 16) at 24 (600) centers in accordance with details for longitudinal construction joint shown on Standard 420001.

A minimum clearance of 2 (50) between the end of the tie bar and the back of the curb shall be maintained.

The dowel bars shown in contraction joints will only be required for monolithic construction.

See Standard 606301 for details of corner islands except reference to Standard 606001 does not apply.

All dimensions are in inches (millimeters) unless otherwise shown.

CONCRETE CURB TYPE B AND COMBINATION CONCRETE CURB AND GUTTER
(Sheet 1 of 2)

B.L.R. 28-1

Illinois Department of Transportation

PASSED January 1, 2022

ENGINEER OF LOCAL ROADS AND STREETS

APPROVED January 1, 2022

ENGINEER OF DESIGN AND ENVIRONMENT

ISSUED 8-1-1-18

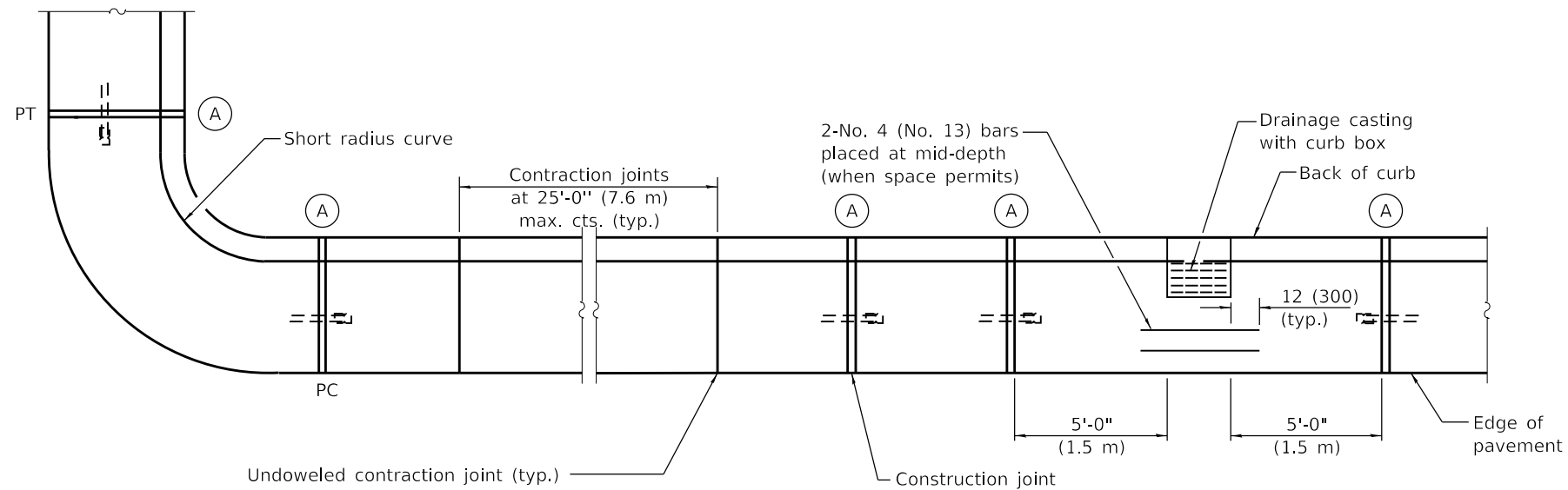

Undoweled contraction joint (typ.) construction options:

1. Form with 1/8 (3) thick steel template 2 (50) deep, and seal.
2. Saw 2 (50) deep at 4 to 24 hours, and seal.
3. Insert 3/4 (20) thick preformed joint filler full depth and width.

PLAN

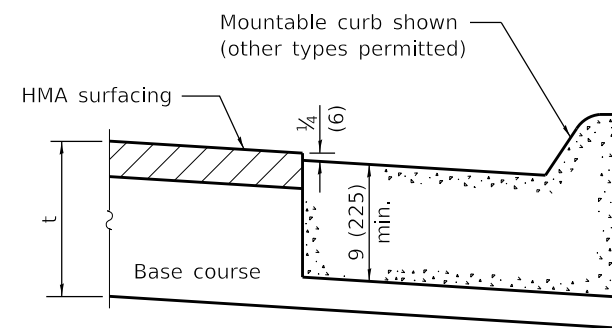
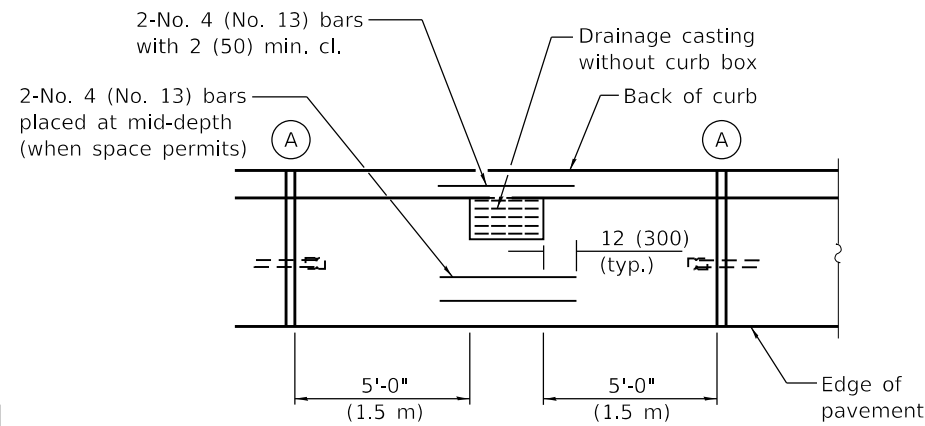

ON DISTURBED SUBGRADE

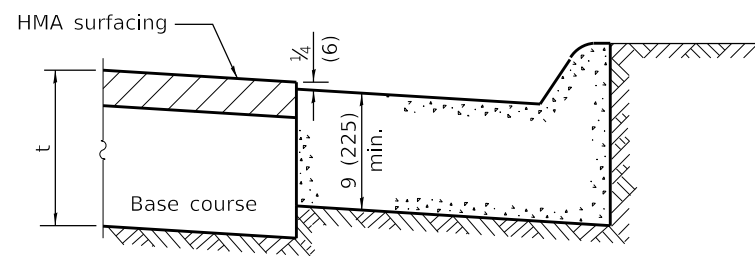

ON UNDISTURBED SUBGRADE

ADJACENT TO FLEXIBLE PAVEMENT

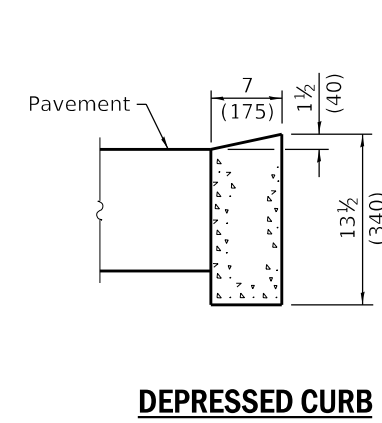

DEPRESSED CURB

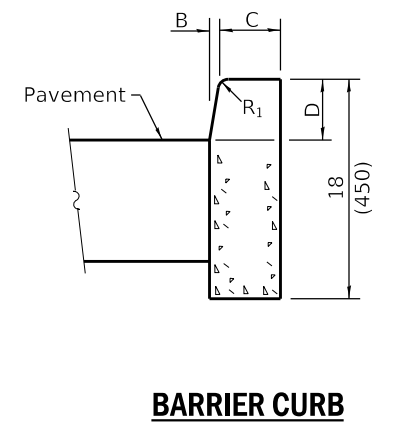

BARRIER CURB

ADJACENT TO FLEXIBLE PAVEMENT

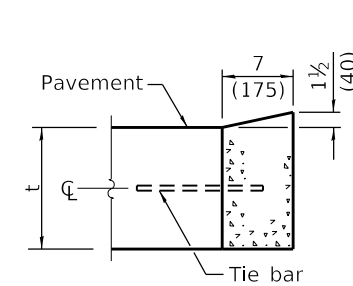

DEPRESSED CURB

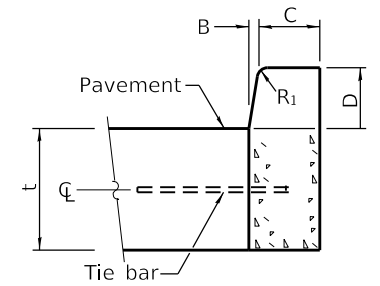

BARRIER CURB

ADJACENT TO PCC PAVEMENT OR PCC BASE COURSE

CONCRETE CURB TYPE B

**CONCRETE CURB TYPE B
AND COMBINATION
CONCRETE CURB AND GUTTER**

(Sheet 2 of 2)

B.L.R. 28-1

Illinois Department of Transportation

PASSED January 1, 2022

ENGINEER OF LOCAL ROADS AND STREETS

APPROVED January 1, 2022

ENGINEER OF DESIGN AND ENVIRONMENT

ISSUED 1-1-18