



# SPECIFIC TASK TRAINING PROGRAM COURSE S-33

*Soils Field Testing and Inspection: Course Reference Manual*







*Specific Task Training Program  
Course S 33*

*Soils Field Testing and Inspection  
Course Reference Manual*

---

Prepared and Published by  
Illinois Department of Transportation  
Office of Highways Project Implementation  
Bureau of Materials

Springfield, Illinois

*November 20, 2024*

---

This page left intentionally blank.



## DOCUMENT CONTROL

The *Specific Tasks Training Program Course S 33: Soils Field Testing and Inspection Course Reference Manual* is reviewed during use for adequacy and updated as necessary by the Bureau of Materials. The approval process for changes to this manual is conducted in accordance with the procedures outlined in the Illinois Department of Transportation's, Document Management Manual.

### **Electronic**

Portable Document Format (PDF) has been selected as the primary distribution format. The official version of the manual is available on the Illinois Department of Transportation website and the Policy and Research Center Library site on InsideIDOT.

### **Hard Copy**

The current version of this manual is distributed in hard copy format as a training aid for each class. Users who choose to print a copy of the manual are responsible for ensuring use of the most current version.

### **Archived Copies**

Archived versions of this manual are available to examine by contacting the Bureau of Materials or the Policy and Research Center at [DOT.PolicyResearchCenter@illinois.gov](mailto:DOT.PolicyResearchCenter@illinois.gov).

**Revision History**

<u>Revision Date</u>	<u>Description</u>	<u>Approval</u>
November 20, 2013	Reissued with minor content and editorial revisions for the 2013-2014 class season.	Daniel Tobias
October 24, 2014	Minor content and editorial revisions for the 2014-2015 class season including updates to discussion in Sections 4 and 8.1, class problems, figures, tables, forms, IDOT website addresses, and references.	Daniel Tobias
November 2, 2016	Minor content and editorial revisions for the 2016-2017 class season including updates to discussion in Section 9.2, class problems, figures, tables, IDOT website addresses, and references.	Heather Shoup
December 3, 2018	Minor content and editorial revisions for the 2018-2019 class season including updates to class problem 3, Figure 20, references and Appendix B.	Heather Shoup
January 26, 2023	Minor content and editorial revisions for the 2023 class season including updates to Ch. 8 to reflect changes in the 2022 Standard Specifications. Class problems, figures, tables, references, and appendices were also updated.	Heather Shoup
December 13, 2023	Minor content and editorial revisions for the 2024 class season. Updated hyperlinks. Updated Ch. 8 to add the minimum moisture content and minimum IBV criteria in embankments.	Heather Shoup
November 20, 2024	Minor content and editorial revisions for the 2024 class season. Updated Ch. 9 to add clarification for MSE wall foundation inspection.	Heather Shoup

# **COURSE REQUIREMENTS FOR SUCCESSFUL COMPLETION**

**Student must attend all class sessions.**

- PREREQUISITE COURSES — None.
- WRITTEN TEST — The test consists of two written parts. Each part will be given at the conclusion of each section of the course: Part A “Soils Field Testing” and Part B “Field Inspection”. Both parts are open book. The time limit is 1 hour for each section. A minimum composite grade of 70 is required.

Note: The Department has no out-of-state reciprocity for this course.

- WRITTEN RETEST — If the student fails the written test, one retest can be performed. The retest is open book. The time limit is 2 hours. A minimum grade of 70 is required. A retest will not be given on the same day as the initial test. A retest must be taken by the end of the academic year that the initial test was taken. The academic year runs from September 1<sup>st</sup> of one year to August 31<sup>st</sup> of the next year. **(For example, if the test was taken December 13, 2022, the last date to retest is August 31, 2023.)** Failure of a written retest, or failure to comply with the academic year retest time limit, shall require the student to retake the class and the test.
- NOTIFICATION — The student will be notified by e-mail with instructions on how to access the IDOT Learning Management System (<http://www.ildottraining.org/ihtml/application/student/interface.idot/index.htm>) to obtain the test results. A certificate of completion will be issued if the student passes the course, and 12 professional development hours earned with this course. Once trained, the Department does not require the individual to take the class again.

Successful completion is required as part of the IDOT process for compliance with the Code of Federal Regulations, 23 CFR 637 and for consultant prequalification in Quality Assurance Testing according to IDOT Policy MAT-15, Quality Assurance Procedures for Construction.



This page left intentionally blank.

# TABLE OF CONTENTS

TITLE PAGE.....	3
DOCUMENT CONTROL.....	I
COURSE REQUIREMENTS FOR SUCCESSFUL COMPLETION .....	III
TABLE OF CONTENTS .....	V
LIST OF FIGURES .....	VII
LIST OF TABLES.....	VIII
<b>PART A: SOILS FIELD TESTING .....</b>	<b>1</b>
1. Introduction, Objectives, and Key Documents .....	1
1.1 Introduction .....	1
1.2 Course Objectives .....	1
1.3 Key Documents .....	1
1.3.1 Contract Documents.....	1
1.3.2 Manuals and Checklists.....	2
1.3.3 Project Geotechnical Reports.....	2
2. Soil Types and Properties .....	3
3. Moisture, Density, and the Standard Proctor .....	5
3.1 Soil Moisture Content .....	5
3.2 Field Moisture Content / Field Soil Drying.....	5
<b>CLASS PROBLEM 1: Determination of Moisture Content in the Lab or the Field.</b> .....	6
3.3 Soil Density and the Standard Proctor Test.....	7
<b>CLASS PROBLEM 2: Determine the SDD and OMC of a Soil .....</b>	<b>11</b>
4. Family of Curves and the One-Point Proctor .....	14
<b>CLASS PROBLEM 3: Determine the SDD and OMC by One-Point Proctor .....</b>	<b>16</b>
5. Field Density measurement and Compaction .....	17
5.1 Nuclear Gauge Testing.....	17
5.2 Sand-Cone Testing.....	18
5.3 Compaction and Moisture Acceptance .....	18
<b>CLASS PROBLEM 4: Determination of Percent Compaction and Percent of             Optimum Moisture.....</b>	<b>19</b>
6. Field Soil Stability and Strength Testing .....	20
6.1 Dynamic Cone Penetrometer (DCP) Testing .....	20
<b>CLASS PROBLEM 5: Determination of IBV using DCP Data.....</b>	<b>22</b>
6.2 Static Cone Penetrometer (SCP) Testing .....	23
6.3 Pocket Penetrometer (PP) Testing .....	24

<b>PART B: FIELD INSPECTION .....</b>	<b>25</b>
7. Subgrade Inspection .....	25
7.1 Subgrade Performance Requirements.....	26
7.2 Treatment Types .....	28
7.2.1 Soil Modification .....	29
7.2.2 Granular Improved Subgrades .....	30
7.2.3 Removal and Replacement .....	30
7.3 Identifying Subgrade Problems.....	31
7.4 Determining Treatment Thickness .....	33
<b>CLASS PROBLEM 6: Determine Required Subgrade Treatment Thickness .....</b>	<b>35</b>
8. Embankment Inspection .....	40
8.1 Ground Preparation and Stability.....	41
8.2 Material Acceptability.....	43
8.3 Placement and Compaction.....	46
8.3.1 Placement of Material.....	46
8.3.2 Compaction of Material .....	47
<b>CLASS PROBLEM 7: Determine the Minimum Percent Compaction Requirement .....</b>	<b>50</b>
8.3.3 Compaction Acceptance and Testing Responsibilities.....	52
8.4 Performance Problems.....	53
8.4.1 Unacceptable Settlement .....	53
8.4.2 Excessive Cut & Fill Slope Movement .....	55
9. Shallow Foundation Inspection for Structures.....	56
9.1 Soil Bearing Verification for Shallow Foundations.....	57
<b>CLASS PROBLEM 8: Determine Required Foundation Treatment Thickness ..</b>	<b>59</b>
9.2 Foundation Preparation for Box Culverts.....	62
10. References.....	63
<b>APPENDICES.....</b>	<b>65</b>
APPENDIX A: TEST PROCEDURES COVERED IN THIS COURSE .....	A-1
APPENDIX B: PPG MISTIC TESTS AND TESTING FREQUENCY.....	B-1
APPENDIX C: FORMS & IDH CHART.....	C-1
Moisture-Density Worksheet.....	C-1
Dynamic Cone Penetration Test Form .....	C-2
Static Cone Penetration Test Form .....	C-3
Field Soil Compaction (Nuclear) Form .....	C-4
IDH Textural Classification Chart .....	C-5
Simplified Flow Chart for Field Identification of Soils.....	C-6



## List of Figures

Figure 1. Graph of Proctor Curve showing the relationship between dry density and moisture content.....	7
Figure 2. Photos of pad-foot roller (a) and smooth-drum roller (b) are examples of equipment commonly used for field compaction.....	8
Figure 3. Photos of Proctor test showing compacting soil in mold (a), trimming soil flush with top of mold (b), and preparing sample for oven-drying to determine moisture content (c). ....	9
Figure 4. Photo of weighing and recording the weight of the wet soil in mold for the Proctor test. ....	10
Figure 5. Example plot of determining Standard Dry Density based on One-Point Proctor data. ....	15
Figure 6. Illustration of a Nuclear Gauge Test with Direct Transmission and Backscatter Procedures. ....	17
Figure 7. Illustration of a Sand Cone Test Apparatus.....	18
Figure 8. Photos of in-place field testing (b) of compacted dry density and moisture content tests results are compared to the Laboratory Proctor (a) test results (SDD and OMC) to determine the percent compaction and percent of optimum moisture. ....	19
Figure 9. Schematic of a Dynamic Cone Penetrometer (DCP). ....	21
Figure 10. Detail drawing of cone tip of the Dynamic Cone Penetrometer (DCP).....	22
Figure 11. Schematic of a Static Cone Penetrometer (SCP).....	23
Figure 12. Photo of a Pocket Penetrometer.....	24
Figure 13. Typical pavement cross section.....	25
Figure 14. Illustration of pavement and subgrade through cut, at-grade, and fill conditions. ....	25
Figure 15. Photo of Fly ash modified Improved Subgrade is fine graded and ready for paving.....	26
Figure 16. Graph and table for thickness design as a function of IBV, Cone Index (CI), Shear Strength, and $Q_u$ for subgrade treatment (granular backfill or modified soil). ....	27
Figure 17. Graph illustrating typical rut depth under construction traffic as a function of IBV, Cone Index (CI), Shear Strength, and $Q_u$ for subgrade treatment.....	28
Figure 18. Photos of rutting (a) and pumping (b) under proof rolling or construction traffic. ....	32
Figure 19. Graph illustrating the effect of moisture content on IBV. ....	32
Figure 20. Graph and table for thickness design as a function of IBV, Cone Index (CI), Shear Strength, and $Q_u$ for subgrade treatment. ....	34
Figure 21. Illustrations of types of embankment construction.....	40
Figure 22. Illustration of embankments constructed over existing pavement.....	41
Figure 23. Illustration of use of restricted material in embankment. ....	46
Figure 24. Illustration of Stepping & Benching Placement.....	47
Figure 25. Minimum Percent (%) Compaction Requirements Based on Location in the Embankment. ....	49
Figure 26. Table and graph of sample settlement plate data and convergence diagram. ....	54
Figure 27. Plot of example determination of actual construction waiting period.....	54
Figure 28. Photos of examples of shallow foundation uses in highway features. ....	56

---

Figure 29. Photo of typical Mechanically Stabilized Earth (MSE) wall (a) with extent of the shallow foundation illustrated (b) .....	57
Figure 30. Illustration for determination of Reduced Applied Bearing Pressure ( $q^*$ ) .....	58

## List of Tables

Table 1. IDH Particle Size Limits of Soil Constituents defined in AASHTO M 146 .....	3
Table 2. Correlation between DCP Penetration Rate, IBV, and $Q_u$ .....	22
Table 3. Correlation between Cone Index, IBV, and $Q_u$ .....	24
Table 4. Aggregate Subgrade Improvement Gradations. ....	30
Table 5. Improved Subgrade Thickness Requirements .....	33
Table 6. Guideline for Aggregate Thickness Reduction Using Geosynthetics. ....	33
Table 7. Suitable and restricted-use soil property limits (Article 1009.04) .....	44
Table 8 Problematic embankment construction materials. ....	45
Table 9. Reduction Factors (RF) for various footing widths (B) at 60 degree load distribution for over excavation depths (D). ....	58
Table 10. Guideline for working platforms at culverts. ....	62

## PART A: SOILS FIELD TESTING

### 1. INTRODUCTION, OBJECTIVES, AND KEY DOCUMENTS

#### 1.1 Introduction

The Specific Task Training Program Course, S 33, “Soils Field Testing and Inspection”, has been prepared to provide basic guidance to construction and materials personnel involved in field testing and inspection of soils and rock. For the purpose of this document, field personnel will be referred to as “Inspector” and the District Geotechnical Engineer will be referred to as “Geotechnical Engineer”. Inspections include excavation, embankment, subgrade, and shallow foundations for various structures. This course also describes common problems and the remedial actions generally used to correct them.

#### 1.2 Course Objectives

In this course, the Inspector will learn how to:

- Determine Standard Dry Density (SDD) and Optimum Moisture Content (OMC) using the Family of Curves and One-Point Proctor
- Determine field moisture content along with in-place wet and (corresponding) dry densities
- Determine percent compaction and percent of OMC
- Determine soil stability and strength in the field using Static and Dynamic Cone Penetrometers
- Check roadway subgrades and determine undercut and treatment depths
- Properly inspect embankment construction
- Perform inspection and soil testing to verify or establish the adequacy of foundation material for box culverts and shallow structure foundations

#### 1.3 Key Documents

##### 1.3.1 Contract Documents

The Inspector should be familiar with the geotechnical information available for a specific contract. Contract documents consist of:

- Specifications and Special Provisions
- Plans and Notes
- Supplemental Specifications and Recurring Special Provisions
- Standard Specifications for Road and Bridge Construction

The Inspector should therefore be familiar with the Department’s *Standard Specifications for Road and Bridge Construction*, as well as any applicable Special Provisions and Plan Notes, such as notes regarding limits of remedial actions, shrinkage values, and so on. The contract plans may not address all geotechnical problems that can be encountered in the field. If additional information is needed, the Geotechnical Engineer may be contacted for assistance.



### 1.3.2 Manuals and Checklists

The Inspector should also be familiar with:

- Project Procedures Guide (PPG)
  - <https://public.powerdms.com/IDOT/documents/2144679/Project%20Procedures%20Guide>
- All necessary Standard Test Procedures (see Appendix A)
- Manual of Test Procedures for Materials
  - <https://public.powerdms.com/IDOT/documents/2732503>
- Construction Inspector Checklists
  - <https://idot.illinois.gov/doing-business/procurements/construction-services/contractor-resources/highways/manuals-and-guides.html>
- Geotechnical Manual
  - <https://public.powerdms.com/IDOT/documents/2001840/Geotechnical%20Manual>
- Subgrade Stability Manual
  - <https://public.powerdms.com/IDOT/documents/2144325/Subgrade%20Stability%20Manual>

### 1.3.3 Project Geotechnical Reports

The Inspector should review all Project Geotechnical Reports. These may include:

- Roadway Geotechnical Reports
- Structure Geotechnical Reports
- Geotechnical Design Memoranda
- Supplemental Geotechnical Reports
- Abbreviated Geotechnical Reports

## 2. SOIL TYPES AND PROPERTIES

Generally speaking, soil types in Illinois can consist of (from coarsest to finest) boulders, cobbles, gravel, sand, silt, and clay. Table 1 shows the particle size limits for different soil constituents.

**Table 1. IDH Particle Size Limits of Soil Constituents defined in AASHTO M 146**

Description		Size Range	
		mm	U.S. Sieve
Boulder <sup>a</sup>		> 305	> 12 in.
Cobble		305 to 75	12 in. to 3 in.
Gravel (& Crushed Stone Aggregate)	Coarse	75 to 25	3 in. to 1 in.
	Medium	25 to 9.5	1 in. to 3/8 in.
	Fine	9.5 to 2.00	3/8 in. to No. 10
Sand	Coarse	2.00 to 0.425	No. 10 to No. 40
	Fine	0.425 to 0.075	No. 40 to No. 200
Silt		0.075 to 0.002	< No. 200
Clay		< 0.002	-

<sup>a</sup> See the applicable sections of the Standard Specifications for minimum boulder sizes eligible for payment, such as 1/2 cubic yard (0.5 cubic meter) for rock excavation in Article 202.04 and Article 502.03.

Soil types are identified not only by their particle size, but by their properties as well. Although accurate identification of soils is normally carried out in the laboratory, the lack of necessary facilities in the field requires the Inspector to make reasonably approximate field identifications. Accordingly, identification and description are based on a combination of experience along with some simple visual and physical identification tests (such as grittiness, cohesiveness, finger pressure, and other sensory assessments). As soil samples are extracted from stockpiles, borings, test pits, or road cuts, they should be approximately identified in the field in terms of texture, color, and engineering classification. For purposes of this course, discussion will pertain to soils comprised of gravel, sand, silt, clay, and organics (generally fine grained). Refer to the Illinois Division of Highways (IDH) Textural Classification Chart in Appendix C for soil types and abbreviations. A simplified flow chart is also provided in Appendix C for guidance on field identification of soils.



**Gravel** is coarse, cohesionless, and generally exhibits a high friction angle and strength. It may be washed or contain fines.



**Sand** is easily identifiable by sight and has very little cohesion. Sand does not ribbon between thumb and finger, and rarely holds together when compressed in the hand. Individual grains are easily seen with the naked eye, even when moist. Sandy soils can be classified as sand, sandy loam, or sandy clay loam.

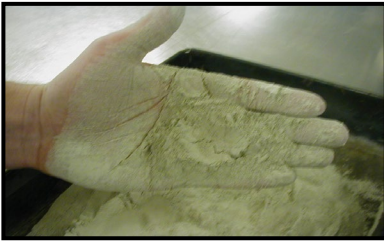

**Silt** is identifiable by its floury consistency. It has low cohesion, shears easily, and does not ribbon well between thumb and finger. Silt crumbles easily when dry, and bleeds water if vibrated in the hand when wet (dilatancy). Silt in the field is notorious for pumping when wet. If it is too wet, it cannot achieve adequate compaction. Silty soils can be classified as silt, silty loam, or silty clay loam.



**Clay** is identified by its high cohesive strength and soapy appearance when smeared with the finger. Clay ribbons very well between the thumb and finger and is extremely difficult to crumble when dry. In a very moist condition, clay becomes very soft and sticky and will display a pitted texture on a broken surface. A fingerprint impression made in clay is well defined. Clayey soils can be classified as clay, clay loam, silty clay, silty clay loam, or sandy clay.

**Organic soils**, such as peat and muck, are made up of organic matter typically consisting of decomposed plant material accumulated under conditions of excessive moisture, and can generally be fibrous, sedimentary, or woody. When peat is decomposed such that recognition of plant forms is not possible, it is referred to as muck. These organic soils are dark colored in nature and may exhibit the odor of decaying vegetation.

### 3. MOISTURE, DENSITY, AND THE STANDARD PROCTOR

Field density and compaction testing is carried out to ensure that subgrades and embankments have been compacted to their required densities. This involves determining the percent compaction of soils in the field based on their in-place soil density. In order to compute the percent compaction, the in-place (field) dry density of the soil must be compared to the Standard Dry Density (SDD), otherwise known as the Proctor Density, that has been established for that soil. The SDD is determined from a moisture-density relationship (Dry Proctor Curve). Compaction testing thus requires both moisture determination and density testing to be carried out.

#### 3.1 Soil Moisture Content

Moisture content is an important soil property, as it correlates with such engineering properties as shear strength, permeability, compressibility, and unit weight. Soil moisture content ( $w$ ) is defined as the ratio (expressed in percent) of the weight of water in the soil to the dry weight of the soil, as given by equation 3-1:

$$\text{Moisture Content, } w (\%) = \frac{\text{Wt. of Water in Soil}}{\text{Wt. of Dry Soil}} \times 100 \quad \text{Eq. 3-1}$$

The moisture content test is simple to perform, requiring only a balance and a means of drying the specimen. The test is conducted by weighing a mass of soil while wet and then drying it to obtain a constant dry weight. The difference of the two weights is the weight of water that was present in the sample when wet. Thus, the numerator and denominator of Equation 3-1 can be defined as follows:

$$\text{Wt. of Water in Soil} = (\text{Wet Soil} + \text{Pan Wt.}) - (\text{Dry Soil} + \text{Pan Wt.}) \quad \text{Eq. 3-1a}$$

$$\text{Wt. of Dry Soil} = (\text{Dry Soil} + \text{Pan Wt.}) - \text{Pan Wt.} \quad \text{Eq. 3-1b}$$

The moisture content test is typically conducted in the laboratory according to Illinois Modified AASHTO T 265, whereby the soil samples are dried in a thermostatically controlled oven for a minimum of 15 hours or until dry. A copy of the test method can be found in the Department's *Manual of Test Procedures for Materials*; also see Appendix A for a complete list of Department test procedures discussed in this course.

#### 3.2 Field Moisture Content / Field Soil Drying

The Inspector in the field often does not have access to a thermostatically controlled drying oven as required by Illinois Modified AASHTO T 265. However, the Inspector may need to quickly obtain an approximate "oven-dry" moisture content in order to perform a nuclear gauge moisture correlation or the One-Point Proctor Test (see Section 4). Thus, any of the following are acceptable for field drying:

- Microwave oven
- Hot plate
- Electric heat lamp
- Portable grill
- Camp stove
- Kitchen stove

Refer to Illinois Modified AASHTO T 310 and T 272, T 191, as well as ASTM D 4643 and D 4959 for additional information (see Appendix A).

**CLASS PROBLEM 1: Determination of Moisture Content in the Lab or the Field.**

In the field lab, moist samples were weighed in their containers, dried in a microwave, and then subsequently weighed after drying. Complete the table below to determine the moisture content of each sample.

Weight of Wet Soil + Container	Weight of Dry Soil + Container	Weight of Container (tare wt.)	Weight of Water in Soil	Weight of Dry Soil	Moisture Content
<i>A</i>	<i>B</i>	<i>C</i>	<i>A - B</i>	<i>B - C</i>	$\frac{A - B}{B - C} \times 100$
(grams)	(grams)	(grams)	(grams)	(grams)	(%)
792.3	608.5	102.2	183.8	506.3	36.3
1129.7	901.1	110.5			
669.5	383.4	97.3			

**Solution Process:** Use equations 3-1a, 3-1b, and 3-1.

Note: When the digit next beyond the last place to be retained (or reported) is equal to or greater than 5, increase by 1 the digit in the last place retained (Illinois Modified ASTM E 29). For example, 1.25 rounds to 1.3.

### 3.3 Soil Density and the Standard Proctor Test

For most Department projects, the moisture-density relationship of soils is obtained via the Standard Proctor Test according to Illinois Modified AASHTO T 99, Method C (refer to the Department's *Manual of Test Procedures for Materials*; also see Appendix A for a complete list of Department test procedures discussed in this course). Note that a soil's moisture content and density are directly related during and after the compaction process.

Based on this moisture-density relationship, greater density almost always results in:

- Greater strengths
- Greater stability
- Less compressibility

A typical moisture-density relationship for a given soil prepared at a known compactive effort is shown below in Figure 1. This moisture-density relationship, in which dry density is plotted versus moisture content, represents the Dry Proctor Curve.

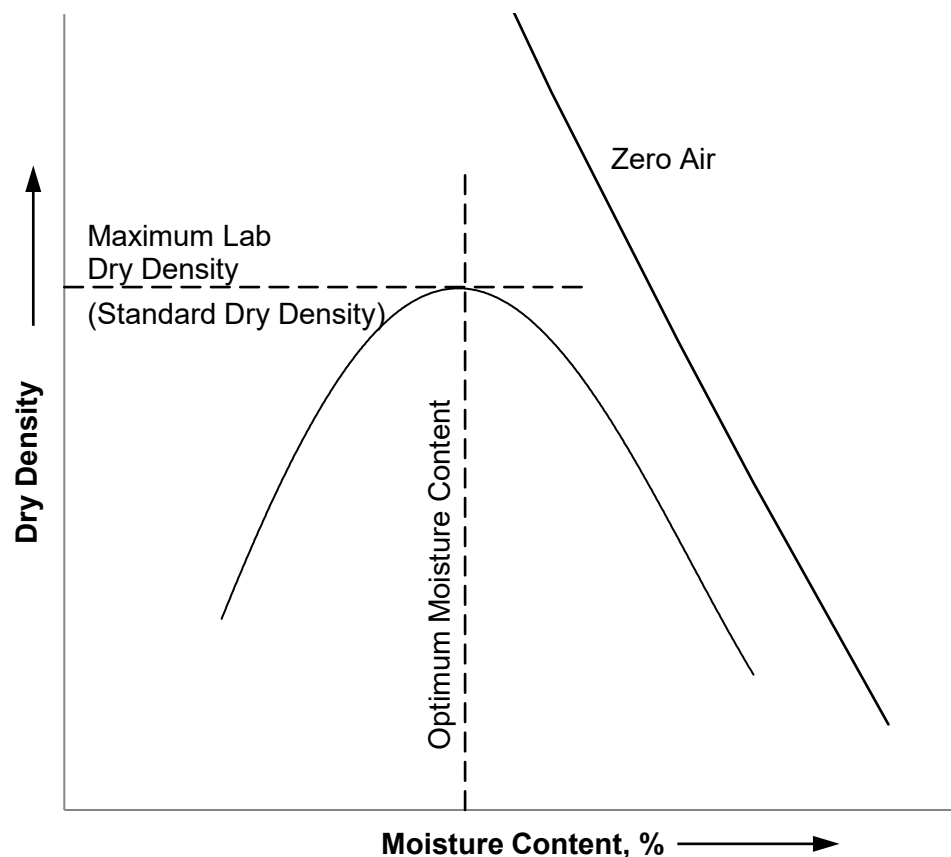

**Figure 1. Graph of Proctor Curve showing the relationship between dry density and moisture content.**

The maximum dry density obtained from the moisture-density relationship is known as the Standard Dry Density (SDD), or the Dry Proctor Density. Furthermore, the soil's moisture content at which this maximum density occurs is known as the Optimum Moisture Content (OMC). The soil stability and the inferred degree of soil strength are influenced by these factors:

1. **Moisture content of the soil.** As moisture content increases from below optimum, the density and strength increase as the material is compacted. Density and strength will continue to increase under the same compactive effort as the moisture approaches optimum, reaching their peak at the OMC. As moisture exceeds optimum (still under the same compactive effort) the density and strength begin to decrease.
2. **Nature of the soil (gradation, chemical, and physical properties).** Of primary concern are the gradation, size, shape, and mineralogical composition of the individual particles. Generally, as soils range from poorly graded to well-graded, the maximum density increases. Well-graded soils contain such a wide range of particle sizes that small particles fill the void spaces between large particles, thereby increasing the maximum density. This situation cannot prevail when the aggregate is gap-graded or uniform in size. Whenever void space is replaced with soil grains, the density is increased. The OMC is a function of the soil specific surface (total surface area of particles per volume). Fine grained soils have larger specific surface than coarse grained soils. This explains why clays exhibit higher OMC than sands.
3. **Type and amount of compactive effort.** In general, as the compactive effort is increased, the maximum density is increased, and the OMC is reduced. The moisture density curve obtained in the laboratory, for a given soil, does not necessarily correspond exactly to the curve that would be obtained in the field, under different compaction conditions. Such field curves, obtained with various rollers at different numbers of passes, do correspond reasonably well with the laboratory curves. Both research and practice indicate that with the proper compaction equipment (Figure 2), no difficulty should be experienced in achieving 95% or more of the laboratory maximum dry density, provided the soil in the field is near the laboratory OMC.



(a)



(b)

Figure 2. Photos of pad-foot roller (a) and smooth-drum roller (b) are examples of equipment commonly used for field compaction.



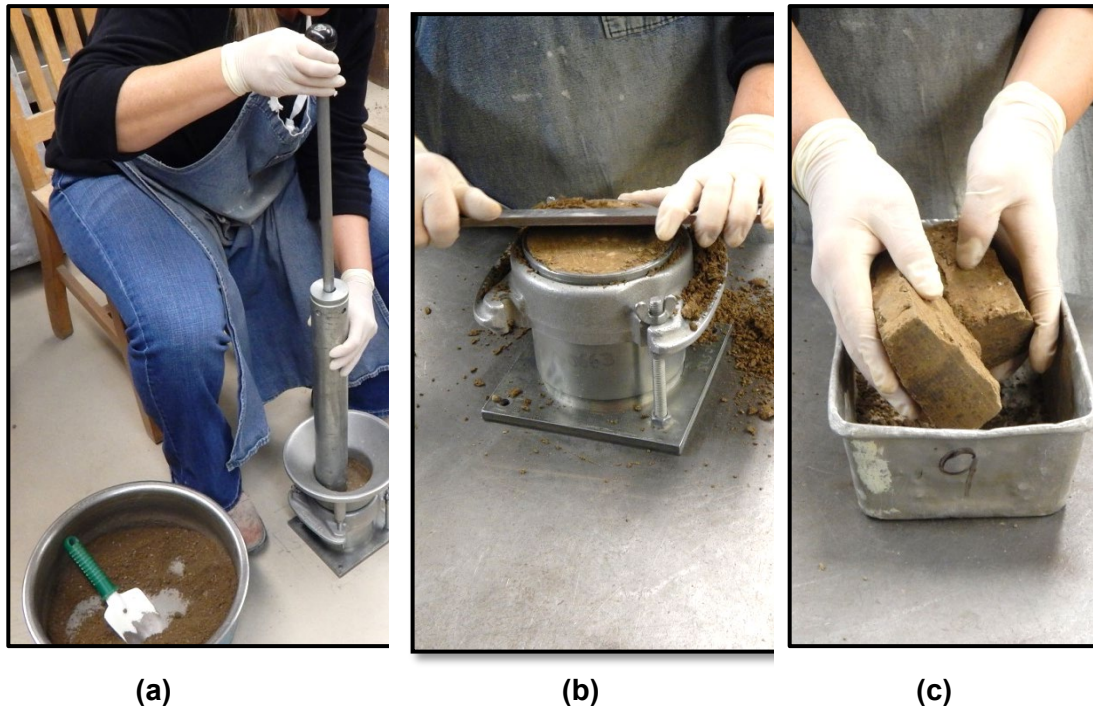

**Figure 3. Photos of Proctor test showing compacting soil in mold (a), trimming soil flush with top of mold (b), and preparing sample for oven-drying to determine moisture content (c).**

To develop the Proctor Curve, a series of moisture-density data points are generated in the laboratory according to Illinois Modified AASHTO T 99, Method C. The basic process is as follows:

- Each data point represents a soil sample compacted at a particular moisture content in a  $1/30 \text{ ft}^3$  mold in three approximately equal layers. Each layer is compacted with 25 blows from a 5.5-lb rammer falling 12 inches (Figure 3, left).
- After the final layer has been compacted and the soil trimmed flush with the top of the mold (Figure 3, center), the sample is weighed (Figure 4) and the wet density is computed.
- Upon compaction, each sample is then oven-dried (Figure 3, right) and its moisture content is computed along with its *dry* density. Once the dry densities and corresponding moisture contents are recorded, the Proctor (moisture-density (relationship) curve(s) can be drawn (Figure 1).
- A minimum of four data points, all at different moisture contents, will need to be compacted and plotted in order to draw a best fit wet curve. **Three of the four data points should be ascending on the wet curve** (an increase in wet densities with an increase in moisture content).



**Figure 4. Photo of weighing and recording the weight of the wet soil in mold for the Proctor test.**

The wet density ( $\gamma_{wet}$ ) is determined with Equation 3-2 as follows:

$$\text{Wet Density, } \gamma_{wet} = \frac{\text{Wt. of Wet Soil in Proctor Mold}}{\text{Volume of Proctor Mold}} \quad \text{Eq. 3-2}$$

However, for ease of computations, use Equation 3-2a:

$$\gamma_{wet} = \text{Wt. of Wet Soil in Proctor Mold} \times \text{Mold Factor} \quad \text{Eq. 3-2a}$$

Where, if using a scale that weighs the mold and soil in *pounds*, the Mold Factor is calculated as follows:

$$\text{Mold Factor} = \frac{1}{\text{Volume of Proctor Mold}} \quad \text{Eq. 3-2b}$$

Or, if using a scale that weighs the soil and mold in *grams*, the Mold Factor requires a unit conversion as follows:

$$\text{Mold Factor} = \frac{1}{\text{Volume of Proctor Mold}} \times \frac{1 \text{ lb}}{454 \text{ g}} \quad \text{Eq. 3-2c}$$

The Mold Factor is a conversion factor incorporating the volume of the mold and the conversion of grams to pounds. That is, based on a mold volume of  $1/30 \text{ ft}^3$  for a 4-inch diameter mold per IL. Mod. AASHTO T 99, Method C and knowing there are 454 grams in a pound, the mold factor =  $0.0661 \text{ lb/g-ft}^3$ . Check the calibration records for the mold and adjust the mold factor for the actual volume of the mold. (Note that the mold factor is different for Method B or Method D, which use a 6-inch diameter mold with a greater mold volume.)

Once the wet density is known, along with the moisture content, the dry density can be determined. Accordingly, dry density ( $\gamma_{dry}$ ) is defined in Equation 3-3 as follows:

$$\text{Dry Density, } \gamma_{dry} = \frac{\text{Wet Density, } \gamma_{wet}}{(w+100)} \times 100 \quad \text{Eq. 3-3}$$

where ( $w$ ) is the moisture content expressed in percentage (see Equation 3-1).

**CLASS PROBLEM 2: Determine the Standard Dry Density (SDD) and the Optimum Moisture Content (OMC) of a Soil.**

Complete the Moisture-Density Worksheet on the next page and determine the SDD and OMC of a soil. (Note that this worksheet is based on form BMPR SL02 shown on Appendix C-1.)

**Solution Process:**

1. **Calculate moisture contents, wet and dry densities.** Complete the third and fourth rows of the worksheet on the next page using equations 3-1a, 3-1b, 3-1, 3-2a, and 3-3.
2. **Plot wet and dry densities versus moisture content.** Once the moisture-density worksheet is completed, the data from the last three columns will be plotted on the graph provided. Plot Wet Density versus Actual Moisture Content (Wet Curve) and Dry Density versus Actual Moisture Content (Dry Proctor Curve) for all four specimens on the same graph.
3. **Draw the best fit Wet Curve.** Note: At least three points must be ascending.
4. **Back-calculate new dry points for dry curve.** Choose two or three new moisture contents to back-calculate extra dry points as additional data in helping to draw the apex of the Dry Proctor Curve. To back-calculate dry points:
  - a) Choose moisture contents in the vicinity of the apparent peak of the dry curve.
  - b) Find new corresponding wet densities for the newly chosen moisture contents.
  - c) Calculate the new dry densities corresponding to the wet densities and their moisture contents as follows:

$$\text{Dry Density, } \gamma_{dry} = \frac{\text{Wet Density corresponding to a chosen Moisture Content}}{\text{Chosen Moisture Content} + 100} \times 100$$

5. **Plot new dry points.** Plot the new back-calculated dry points from Step 4.
6. Draw the best fit Dry Proctor Curve.
7. Determine the SDD and OMC from the newly drawn Dry Proctor Curve.

**Step 1.** Complete the moisture-density worksheet below.

Starting Sample Dry Weight: <u>5000 g</u> Mold Weight: <u>4154 g</u> Mold Factor: <u>0.0661</u>											
Target Moisture Content (%)	Added Water Volume (cc)	Wet Soil in Mold Weight (g)	Pan No.	Pan Weight (tare) (g)	Wet Soil + Pan Weight (g)	Dry Soil + Pan Weight (g)	Water in Soil Weight (g) [3-1a]	Dry Soil Weight (g) [3-1b]	Actual Moisture Content (%) [3-1]	Wet Density (pcf) [3-2a]	Dry Density (pcf) [3-3]
5	250	1784	2	105.3	626.5	601.2	25.3	495.9	5.1	117.9	112.2
7	90	1867	6	102.6	632.5	598.7	33.8	496.1	6.8	123.4	115.5
9	80	1900	9	99.8	625.3	583.7					
11	70	1879	3	100.4	659.5	607.3					

$Wt. of Water in Soil = (Wet Soil + Pan Wt.) - (Dry Soil + Pan Wt.)$  Eq. 3-1a

$Wt. of Dry Soil = (Dry Soil + Pan Wt.) - Pan Wt.$  Eq. 3-1b

$Moisture Content, w (\%) = \frac{Wt. of Water in Soil}{Wt. of Dry Soil} \times 100$  Eq. 3-1

$Wet Density, \gamma_{wet} = Wt. of Wet Soil in Proctor Mold \times Mold Factor$  Eq. 3-2a

$Dry Density, \gamma_{dry} = \frac{Wet Density, \gamma_{wet}}{(w+100)} \times 100$  3-3

**Step 2.** Plot wet and dry densities versus actual moisture content on the next page.

**Step 3.** Draw the best fit Wet Curve using the data points plotted in step 2.

**Step 4.** Take two points from the Wet Curve and back-calculate two dry data points. For example:  
 @ 7.5% and 8.0%. (Choose wet densities from **your** curve... not from table below.)

Moisture Content Chosen	Instructor's Picks Corresponding Wet Density from Wet Curve	Calculated Dry Density corresponding to chosen Moisture Content
7.5 %	124.7 pcf	116.0 pcf
8.0 %	125.2 pcf	115.9 pcf

$Dry Density, \gamma_d = \frac{Wet Density corresponding to a chosen Moisture Content}{Chosen Moisture Content + 100} \times 100$

**Step 5.** Plot the back-calculated dry points on the graph below.

**Step 6.** Complete the drawing of the Dry Proctor Curve using the extra points plotted in step 5.

**Step 7.** Determine Standard Dry Density (SDD) and Optimum Moisture Content (OMC).

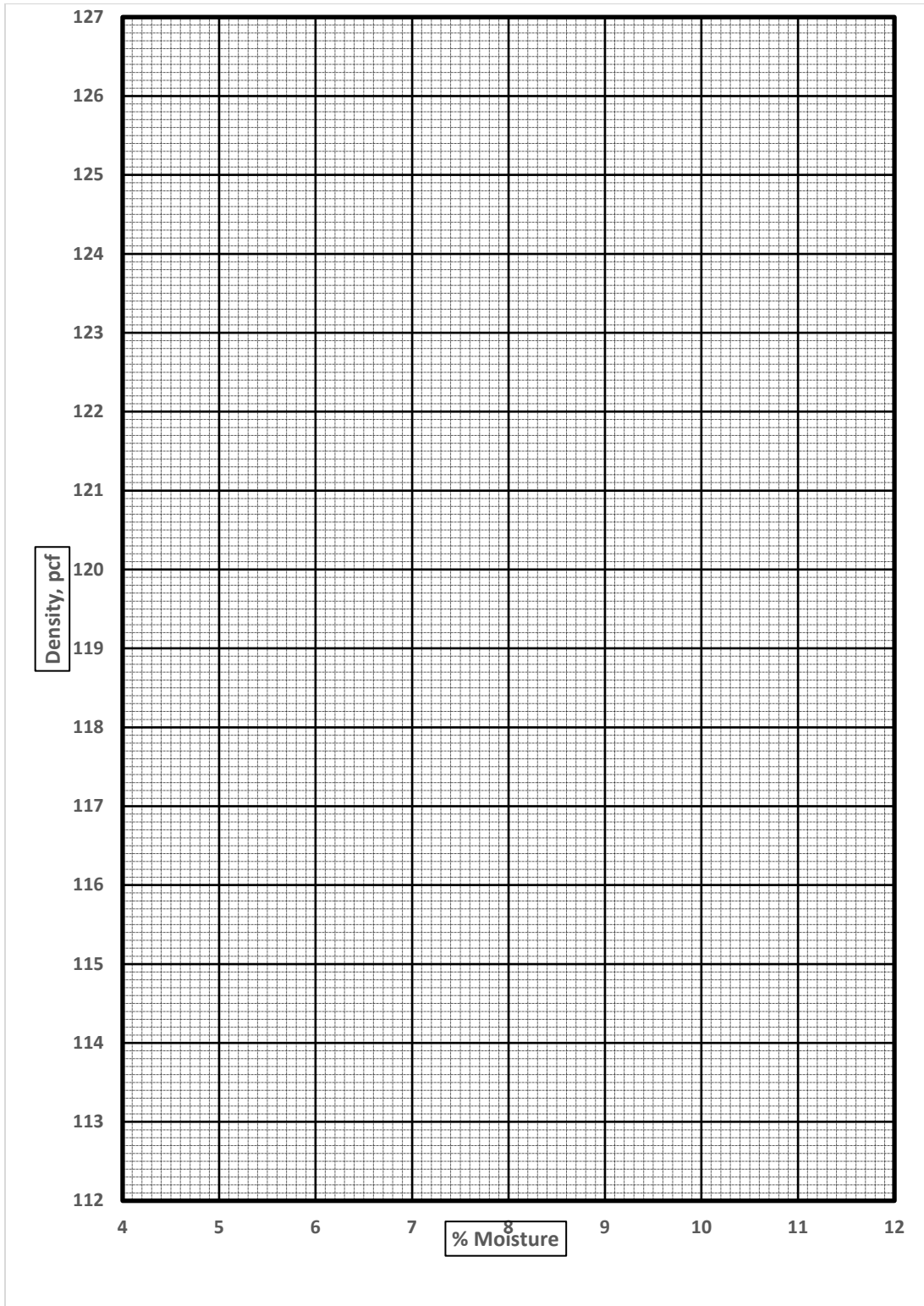

Proctor Density, SDD = \_\_\_\_\_

Optimum Moisture Content, OMC = \_\_\_\_\_

#### 4. FAMILY OF CURVES AND THE ONE-POINT PROCTOR

For many types of construction, it is often impractical to perform a complete moisture-density relationship for all soils encountered. This is particularly true for highway construction because of the great number of different soil types that are encountered. It would be both time consuming and uneconomical to establish a Proctor curve for each new soil type. However, numerical values for the Standard Dry Density and Optimum Moisture Content for each soil are needed for comparison with the in-place field measurements in order to determine if the field compaction and moisture content meet the construction specifications. The SDD and the OMC can be approximated by using the One-Point Proctor and Family of Curves method outlined in Illinois Modified AASHTO T 272 and Illinois Modified AASHTO R 75 (see Appendix A).

On projects with a significant quantity of earthwork, the Geotechnical Report may contain a project-specific Family of (Proctor) Curves for excavated material. The Geotechnical Engineer may also develop a project-specific Family of Curves when a variety of borrow or furnished materials are encountered that may be mixed prior to placement.

A simplified procedure is the One-Point Proctor test, in which one dry density and its corresponding moisture content are determined. The One-Point Proctor test can be performed in the field or in the laboratory in a relatively short period of time. The procedure is as follows:

- A soil sample from the field test site is obtained.
- The sample is then compacted in a 4-in. diameter mold, according to Illinois Modified AASHTO T 99, Method C.
- The mold is struck-off, and the compacted specimen is weighed.
- The sample is extruded from the mold and a portion is used to determine the moisture content by either oven-drying or drying by one of the permissible field methods discussed in Section 3.2.
- The moisture content and the dry density of the compacted sample can then be calculated using Equations 3-1 and 3-3, respectively.
- The **dry** density and moisture content from the one-point Proctor is plotted on the Family of Curves (Figure 5).

The plotted one-point should fall between 80% and 100% of OMC. If the point falls on an existing curve, the SDD and OMC defined by that curve should be used. If the one-point falls between existing curves, the curve immediately above the one-point should be chosen, provided the curve is within 2-lbs of the plotted one-point. If the one-point does not come within 2 lbs of any curve, or plots off the existing Family of Curves, or if there is a question regarding data validity, contact the Geotechnical Engineer. A complete laboratory moisture-density relationship may be required.

### Family of Curves (District 6)

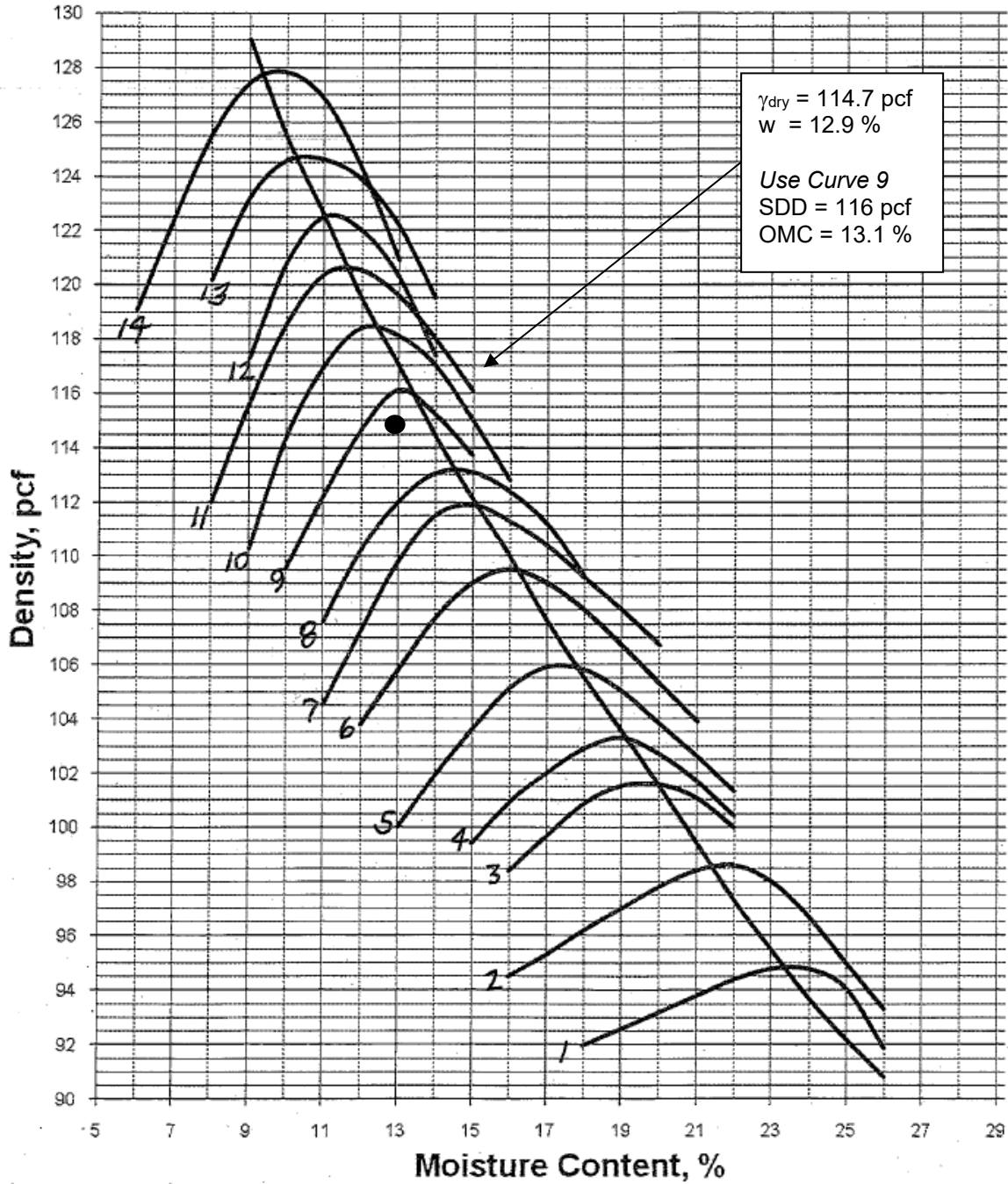

Figure 5. Example plot of determining Standard Dry Density based on One-Point Proctor data.



**CLASS PROBLEM 3: Determine the Standard Dry Density (SDD) and Optimum Moisture Content (OMC) of a soil by the One-Point Proctor Test.**

**Solution Process:** Complete the last five columns of the table below. On the Family of Curves figure below, plot the data point corresponding to the Dry Density and Actual Moisture Content, and choose the appropriate Proctor Curve. Report the SDD and OMC. Compute all values in exactly the same manner as in Class Problem 2.

**One-Point Proctor Test Data**

Target Moisture Content (%)	Added Water Weight (g)	Wet Soil in Mold Weight (g)	Pan No.	Pan Weight (g)	Wet Soil + Pan Weight (g)	Dry Soil + Pan Weight (g)	Water in Soil Weight (g)	Dry Soil Weight (g)	Actual Moisture Content (%)	Wet Density (pcf)	Dry Density (pcf)
—	—	1817	2	103.1	832.5	752.0					

Remember: Wet Density = Wet Soil in Mold Weight x Mold Factor = Column 3 x 0.0661

**Family of Curves**  
(District 6)

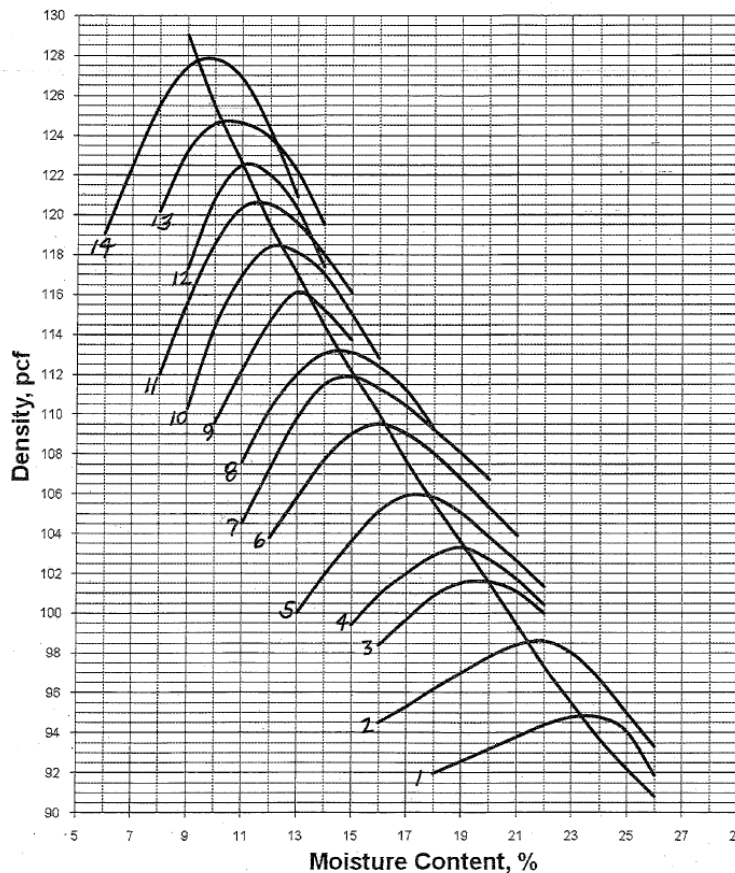

Curve Number \_\_\_\_\_ SDD = \_\_\_\_\_ OMC = \_\_\_\_\_

## 5. FIELD DENSITY MEASUREMENT AND COMPACTION

Subgrade and embankment soils need to be compacted to a minimum density with an acceptable moisture content.

- SDD is used to determine in-place field density acceptability
  - Specifications set minimum % Compaction required
- OMC is used to determine in-place field moisture acceptability
  - Specifications set maximum % of OMC allowed

Density can be measured in the field by either the Nuclear Gauge or by the Sand Cone Test. Moisture is measured as previously discussed in Section 3.

### 5.1 Nuclear Gauge Testing

The field dry density is determined by the nuclear gauge method according to Illinois Modified AASHTO T 310 (see Appendix A) using the direct transmission procedure. In this procedure, the total or wet density is determined by the attenuation of gamma radiation where a source is placed at a known depth up to 12 inches, while the detector remains at the surface. With appropriate gauge calibration and adjustment of data, the wet density is determined. The moisture content of the in-situ soil is also determined by the nuclear gauge using the backscatter procedure. In this procedure, the thermalization or slowing of fast neutrons is measured with both the neutron source and the thermal neutron detector at the surface. The dry density is then computed from the wet density, using Equation 3-3. Figure 6 shows the test gauge performing both procedures.

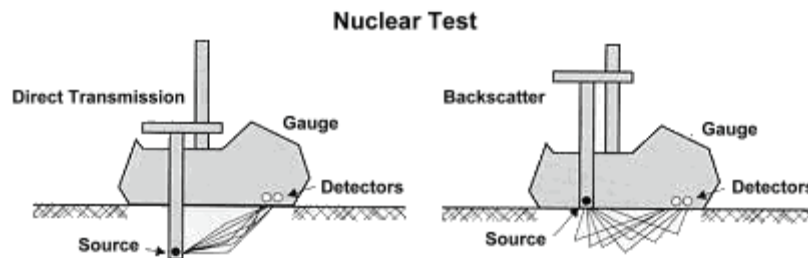

**Figure 6. Illustration of a Nuclear Gauge Test with Direct Transmission and Backscatter Procedures.**

The moisture content measured by the gauge frequently differs from that determined by “oven-drying” a soil sample from directly beneath the gauge test location. This difference is due to the chemical composition of the sample. Hydrogen in forms other than water and carbon will cause nuclear gauge measurements in excess of the true value. Examples are road oil and asphalt. Chemically bound water, such as found in gypsum, will also cause measurements in excess of the true value. Some chemical elements such as boron, chlorine, and minute quantities of cadmium will cause measurements lower than the true value. Soils containing iron or iron oxides, having a higher capture cross section (absorption of neutrons), will cause measurements lower than the true value. Refer to Illinois Modified AASHTO T 310 for sampling soil at the test location to determine the “oven-dried” moisture and adjusting the gauge test results to determine the dry density and percent compaction.

## 5.2 Sand-Cone Testing

The sand cone method is sometimes used when a nuclear gauge is not available. The general procedure involves excavating a hole in the material to be tested and filling the void with an equal volume of sand using the apparatus shown in Figure 7. Thus, the exact volume of soil removed can be determined. Upon weighing the entire contents of the excavated material along with knowing the exact volume of material removed, a wet density can then be calculated. Furthermore, once a field moisture test is performed on the wet material, the dry density is computed. The specific procedure for this test can be found in Illinois Modified AASHTO T 191 (see Appendix A).

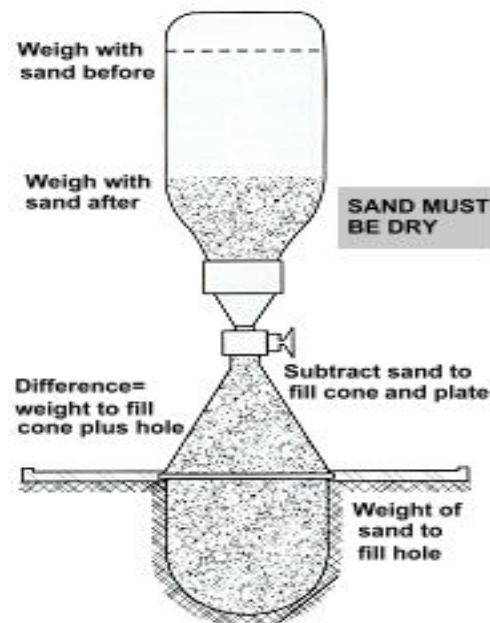

Figure 7. Illustration of a Sand Cone Test Apparatus.

## 5.3 Compaction and Moisture Acceptance

In order to assess the degree of compaction during construction, in-place field dry densities and moisture contents are expressed as a percentage of the Standard Dry Density and Optimum Moisture Content, respectively. The percent compaction and percent of optimum moisture in the field are determined by the following equations:

$$\% \text{ Compaction} = \frac{\text{In-Place Field Dry Density}}{SDD} \times 100 \quad \text{Eq. 5-1}$$

$$\% \text{ Optimum Moisture} = \frac{\text{In-Place Field Moisture Content}}{OMC} \times 100 \quad \text{Eq. 5-2}$$



**Figure 8. Photos of in-place field testing (b) of compacted dry density and moisture content tests results are compared to the Laboratory Proctor (a) test results (SDD and OMC) to determine the percent compaction and percent of optimum moisture.**

---

**CLASS PROBLEM 4: Determination of Percent Compaction and Percent of Optimum Moisture.**

Complete the worksheet below to determine the percent compaction and percent of optimum for each of the three cases.

**Solution Process:** Use equations 5-1 and 5-2.

In-Place Field Dry Density (pcf)	In-Place Field Moisture Content (%)	Standard Dry Density (pcf)	Optimum Moisture Content (%)	Percent Compaction (%)	Percent of Optimum (%)
100.3	11	108.0	12	92.9	91.7
108.2	14	111.6	16		
101.2	16	94.0	13		

## 6. FIELD SOIL STABILITY AND STRENGTH TESTING

### 6.1 Dynamic Cone Penetrometer (DCP) Testing

The Dynamic Cone Penetrometer, or DCP (Illinois Test Procedure 501, see Appendix A), is primarily used to determine the immediate bearing value (IBV) of treated or untreated subgrade. The IBV is used to evaluate subgrade stability and determine the depth of subgrade treatment. The DCP is also used to determine the unconfined compressive strength ( $Q_u$ ) of foundation bearing soils.

The DCP consists of a graduated stainless-steel rod approximately 40 inches long with a cone attached to one end and an anvil attached to the other. A sliding hammer, weighing 17.6 lbs, is used to drive the instrument into the ground by dropping 22.6 inches. The DCP assembly and its components are shown in Figure 9.

Testing involves driving the cone into the material to be tested and recording the number of blows for every 6± inches of penetration. After the cone has been seated and an initial reading is taken, the number of blows is recorded for each depth increment. (Note that the cone may not be driven in exact 6 inch increments every time and may fall short or exceed 6 inches upon the last blow for that increment.) The test is repeated to a total depth of at least 18 inches and up to 36 inches. Knowing the number of blows per each increment, along with the depth of penetration within the increment, a penetration rate can be calculated. Once the penetration rate, or “Rate”, within each increment is known, then the IBV can be easily determined.

The Dynamic Cone Penetration Test worksheet (BMPR SL30 form) may be used to record and calculate data. The worksheet is included in Appendix C-2. An example from the worksheet is as follows:

Test Location and Remarks	Initial Depth		A	B	C	D	E
STA 12+00,	4 in.	Depth	4-10	10-16	16-22	22-28	28-34
O/S 8 ft RT		Blows	1	4	3	10	7
Wet SiC		Rate	6	1.5	2	0.6	0.9
Cut/Fill Transition		IBV	< 1	4	3	13	8
		Qu	< 0.3	1.3	1.0	4.2	2.6

Initial Depth = Depth of the DCP cone tip at start of test (will penetrate in soft soils).

Depth = Depth range (in inches) for each depth increment.

Blows = The number of blows for each depth increment (i.e., ideally 6-in.).

Rate = Inches of penetration per blow. For example, the Rate in column “A” equals the Depth range 4 to 10, (or 6 inches) divided by number of Blows ‘1’. The Rate in column “C” equals the Depth range 16 to 22, (or 6 inches) divided by number of Blows ‘3’.

Once the Rate has been calculated, the IBV can be determined in a couple of ways. Firstly, it may be directly obtained from Equation 6-1:

$$IBV = 10^{0.84 - 1.26 \times \log(\text{Rate})} \quad \text{Eq. 6-1}$$

where: Rate is stated as inches per blow.

Secondly, the IBV may be determined more easily by using Table 2 (interpolation may be needed). After determining the IBV, then a  $Q_u$  strength (tsf) can be correlated from the IBV using Equation 6-2. Table 2 also includes the  $Q_u$  correlation.

$$Q_u = 0.32 \times IBV \quad 6-2$$

Where,  $Q_u$  is in units of tons per square foot (tsf).

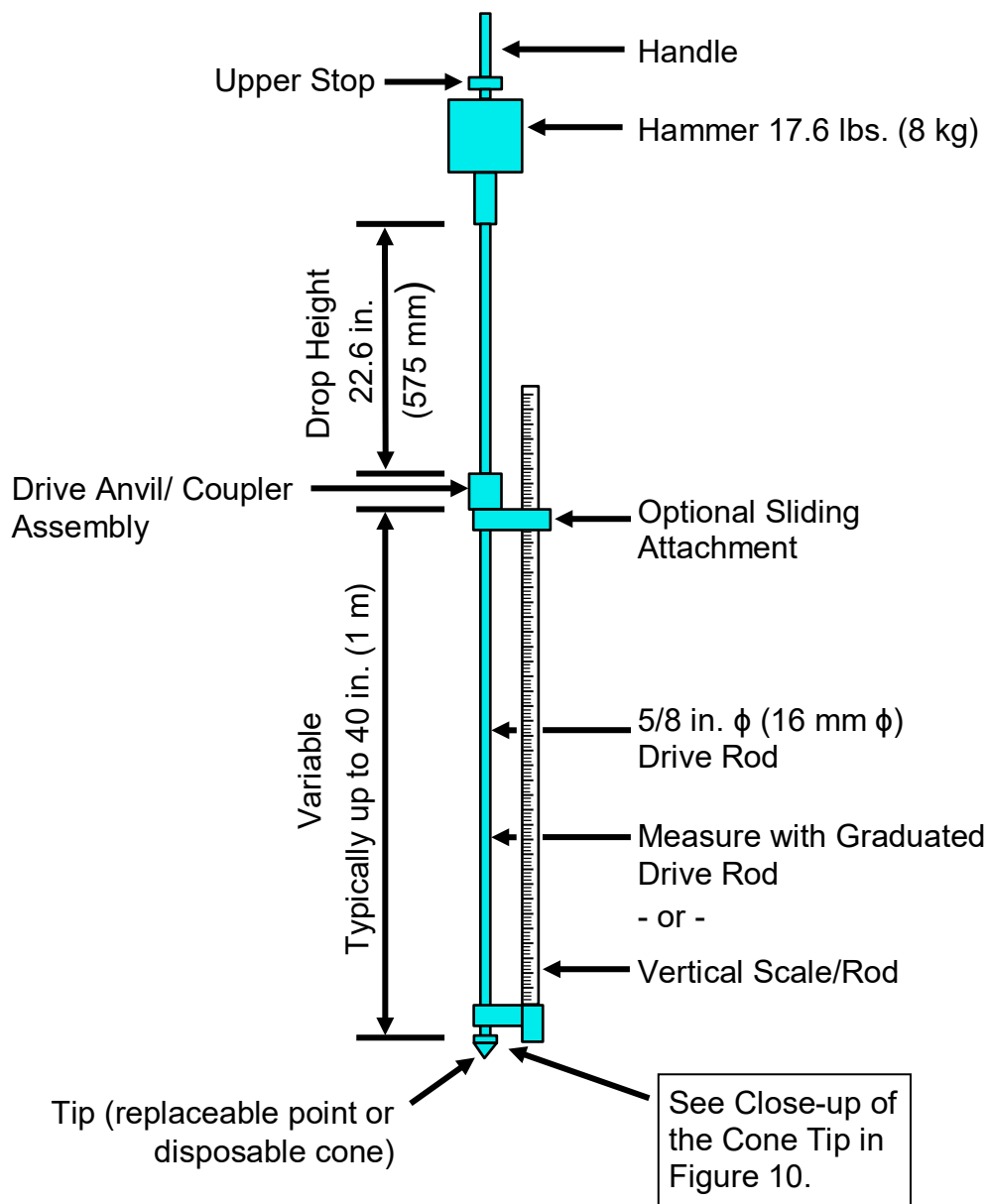
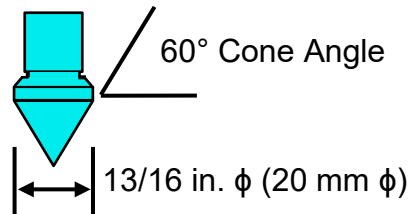

Figure 9. Schematic of a Dynamic Cone Penetrometer (DCP).



**Figure 10. Detail drawing of cone tip of the Dynamic Cone Penetrometer (DCP).**

**Table 2. Correlation between DCP Penetration Rate, IBV, and  $Q_u$ .**

Rate (in./blow)	IBV	$Q_u$ (tsf)
0.3	32	10.2
0.4	22	7.0
0.5	17	5.4
0.6	13	4.2
0.7	11	3.5
0.8	9	2.9
0.9	8	2.6
1.0	7	2.2
1.1	6	1.9
1.3	5	1.6
1.5	4	1.3
2.0	3	1.0
2.7	2	0.6
3.4	1.5	0.5
4.6	1	0.3
> 4.6	< 1	< 0.3

**CLASS PROBLEM 5: Determination of Immediate Bearing Value (IBV) using Dynamic Cone Penetrometer (DCP) Data.** Complete the portion of the DCP worksheet shown below to find the Rate, IBV and  $Q_u$  for each depth interval.

**Solution Process:** Calculate the Rate for each interval as discussed above in Section 6.1. Once the Rates are determined, find the corresponding IBV and  $Q_u$  values by using Table 2 or by calculations using Equations 6-1 and 6-2.

Test Location and Remarks	Initial Depth		A	B	C	D	E
STA 12+85	0 in.	Depth	0 – 6	6 – 13	13 – 18	18 – 24.4	24.4 – 30
12 ft Left of CL		Blows	8	2	7	4	10
		Rate					
		IBV					
		$Q_u$					



## 6.2 Static Cone Penetrometer (SCP) Testing

The Static Cone Penetrometer (SCP) (Illinois Test Procedure 502, see Appendix A), is primarily used to determine the IBV of unstable, untreated subgrades.

The SCP consists of a graduated stainless-steel rod 18 in. long with a cone attached to one end and a proving ring and handle with a dial gauge attached to the other. The rod is usually graduated in 1-inch to 6-inch intervals. The SCP is shown in Figure 11.

The dial gauge directly reads in units of pounds per square-inch (psi) typically ranging between 0 and 300 psi, though sometimes higher. This dial reading is known as the Cone Index (CI) and is used to compute the IBV. Check the calibration records. The dial reading may require an adjustment from a correlation chart or graph in the calibration records.

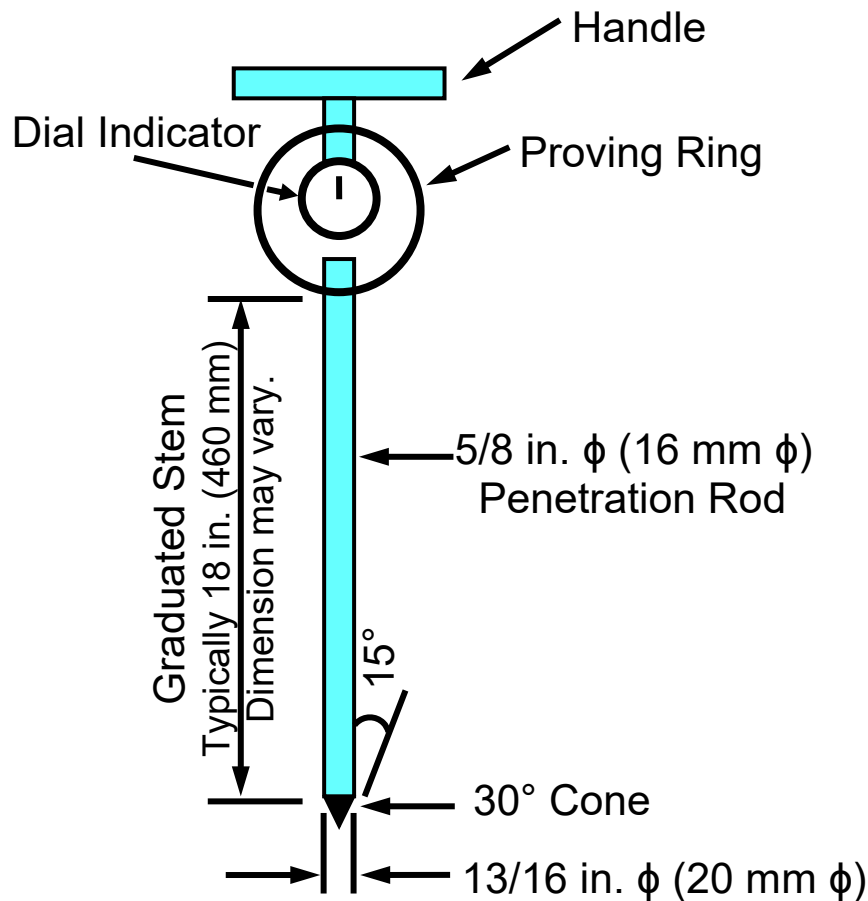

**Figure 11. Schematic of a Static Cone Penetrometer (SCP).**

The IBV may be determined using Table 3 or directly obtained from Equation 6-3:

$$IBV = \frac{CI}{40} \quad \text{Eq. 6-3}$$

Where CI is the Cone Index (psi), read directly from the dial gauge. The Static Cone Penetration Test worksheet (BMPP SL31 form) is included in Appendix C-3 and is used to record and calculate data.

The IBV is correlated to the  $Q_u$  in the same manner as the DCP using Equation 6-2. Thus, one can use the DCP or the SCP to verify soil unconfined compressive strengths in the field. Table 3 shows the correlation between Cone Index (CI), IBV, and  $Q_u$ .

**Table 3. Correlation between Cone Index, IBV, and  $Q_u$ .**

Cone Index	IBV	$Q_u$ (tsf)
300	7.5	2.4
280	7	2.2
240	6	1.9
200	5	1.6
160	4	1.3
120	3	1.0
80	2	0.6
40	1	0.3

### 6.3 Pocket Penetrometer (PP) Testing

A commonly used approximation for the unconfined compression strength test can be performed using a hand-size calibrated penetration device called a pocket, or hand penetrometer. Although the pocket penetrometer test can be used to estimate the strength of cohesive soils, it should only be used as a reconnaissance tool and not as an accurate means of verifying soil strength in the field. The device, which consists of a calibrated spring and a 0.25 inch diameter piston encased inside a metal casing, is shown in Figure 12.

When the piston is pressed, by hand, at a constant rate to penetrate 0.25 inch (the etched line on the piston) into the soil, the calibrated spring is compressed into the penetrometer giving an unconfined compression strength  $Q_u$  (tsf) reading on a scale. The extremely small area of the piston, the skill of the operator, and the particular spot on the sample where the piston is applied influence the strength value obtained. Thus, several penetrometer readings may need to be taken and judgment applied to their results in order to better estimate strength.



**Figure 12. Photo of a Pocket Penetrometer.**

## PART B: Field Inspection

### 7. SUBGRADE INSPECTION

The subgrade is defined in Article 101.47 of the Standard Specifications as the “top surface” of a roadbed upon which the pavement and shoulders are constructed. The roadbed is “prepared as a foundation for the pavement structure and shoulders” (Article 101.36). As such, subgrade inspection evaluates about the “top 2 feet” of the roadbed.

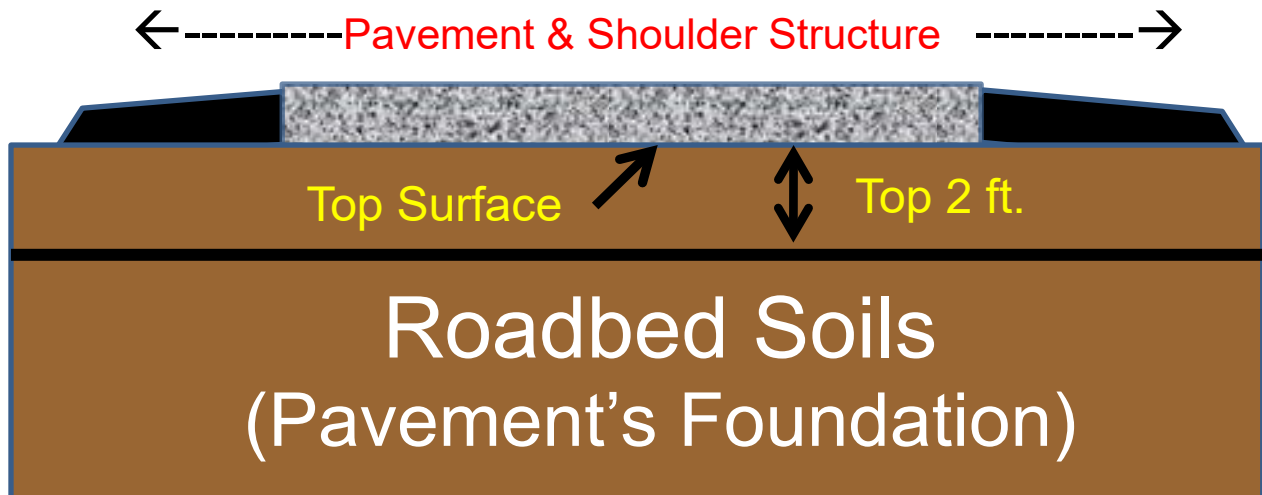

Figure 13. Typical pavement cross section.

Subgrades may be encountered in a cut section, at-grade, or in an embankment fill section as shown below.

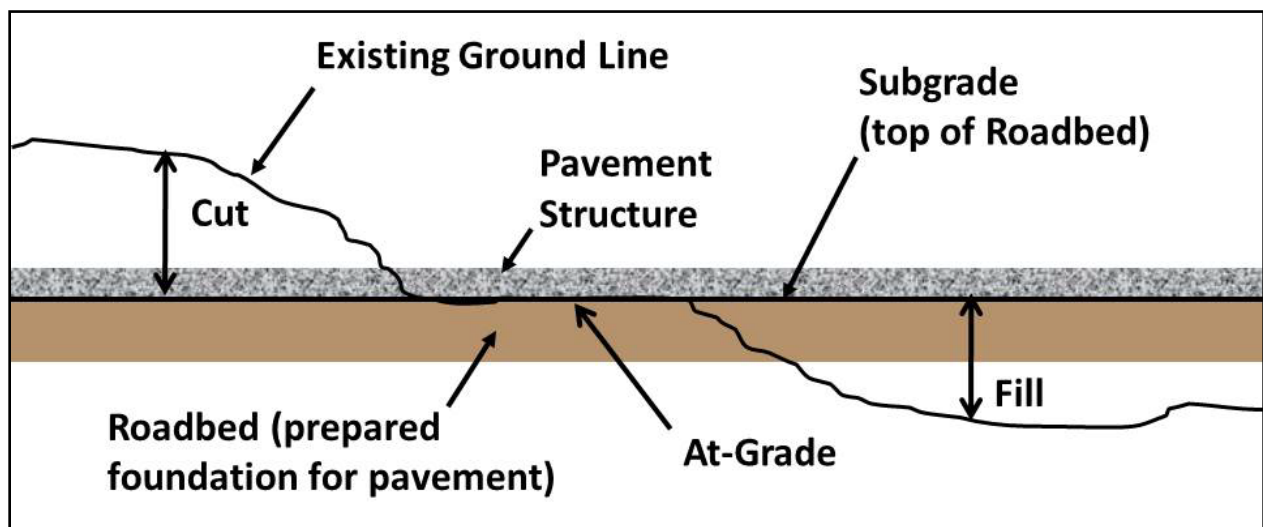

Figure 14. Illustration of pavement and subgrade through cut, at-grade, and fill conditions.

Subgrade inspection includes the following components:

- Subgrade performance requirements
- Treatment types
- Identifying subgrade problems
- Determining treatment thickness

### 7.1 Subgrade Performance Requirements

Subgrade inspection is necessary to meet the following performance requirements:

- Prevent excessive rutting and shoving during construction;
- Provide uniform support for placement and compaction of pavement layers
- Minimize impacts of excessive volume change and frost
- Limit pavement resilient (i.e., rebound) deflections to acceptable limits
- Restrict permanent deformation leading to dips in the pavement

Article 301.04 of the Standard Specifications specifies several requirements including:

- Subgrades shall be compacted to have a dry density  $\geq 95\%$  SDD
- Subgrades shall be compacted to have an immediate bearing value (IBV)  $\geq 8.0$
- Subgrades shall have construction traffic rutting  $< \frac{1}{2}$  in.
- Subgrades in cut sections shall be constructed as follows:
  - Cut plan ditches at least to grade  $\geq 2$  weeks prior to diking
  - Disk or till the subgrade 8 in. deep at least twice daily and allow to dry for 3 consecutive good drying days
  - Recompect to required density requirements



**Figure 15. Photo of Fly ash modified Improved Subgrade is fine graded and ready for paving.**

Most Illinois soils do not provide an adequate IBV for construction of the overlying pavement, even after diskings, drying, and compacting to the required density. Therefore, an Improved Subgrade layer is usually indicated on the plans. An Improved Subgrade is a subgrade modified to meet the performance requirements mentioned above. The following chart illustrates how to establish treatment thickness for Improved Subgrades.

By policy, on state routes, a minimum of 12 inches of Improved Subgrade is required regardless of the native soil IBV. This policy assumes that, typically, the native soil does not have adequate stability (i.e.,  $IBV \geq 8$ ). However, there have been occasions when the in-place soil has an IBV greater than 8 and the soil type is high quality. If this situation is encountered, notify the Field Engineer, Geotechnical Engineer, or the Resident Engineer (RE) to determine if an Improved Subgrade may be reduced in thickness. For all other locations, in order for the 12 inch thickness to be adequate, an IBV of 3 or more must be present below the Improved Subgrade as shown in Figure 16.

### IBV BASED REMEDIAL ACTION

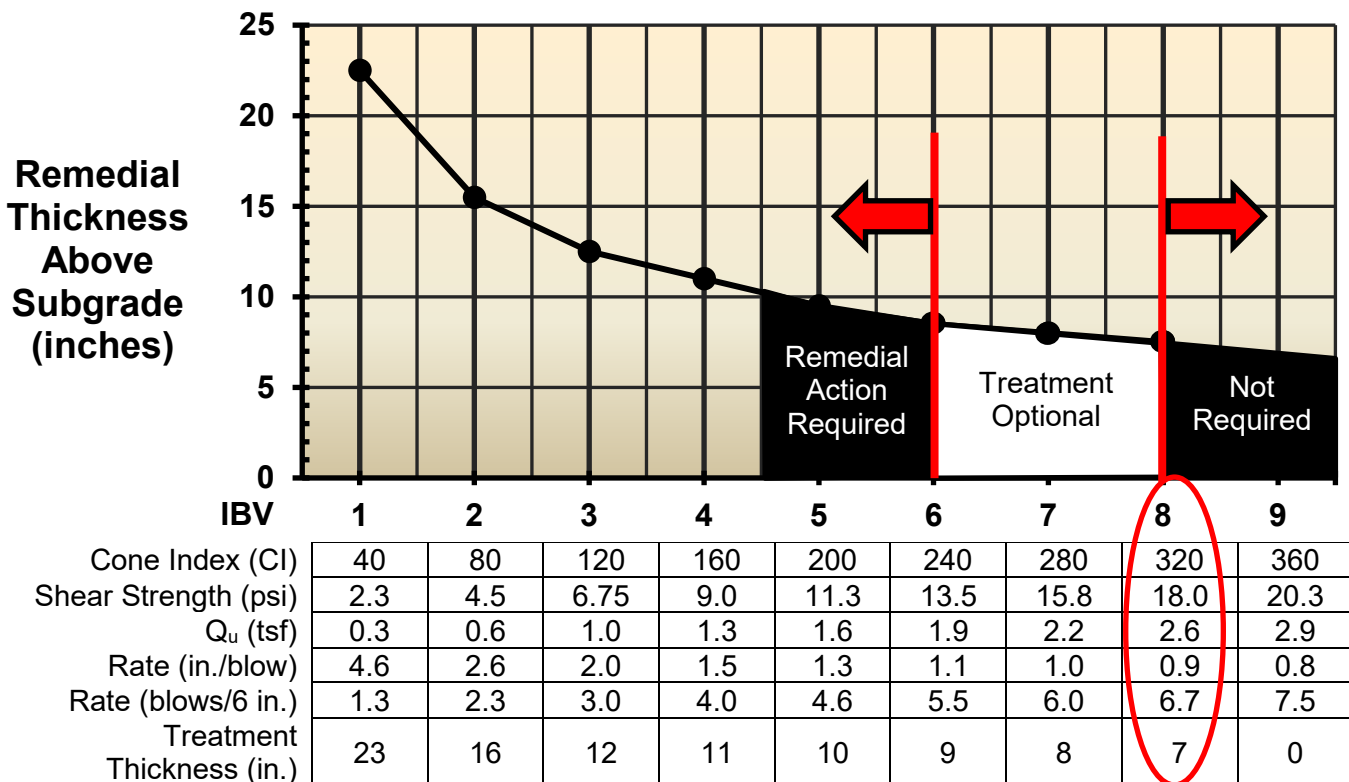

Figure 16. Graph and table for thickness design as a function of IBV, Cone Index (CI), Shear Strength, and  $Q_u$  for subgrade treatment (granular backfill or modified soil).

### IBV BASED REMEDIAL ACTION

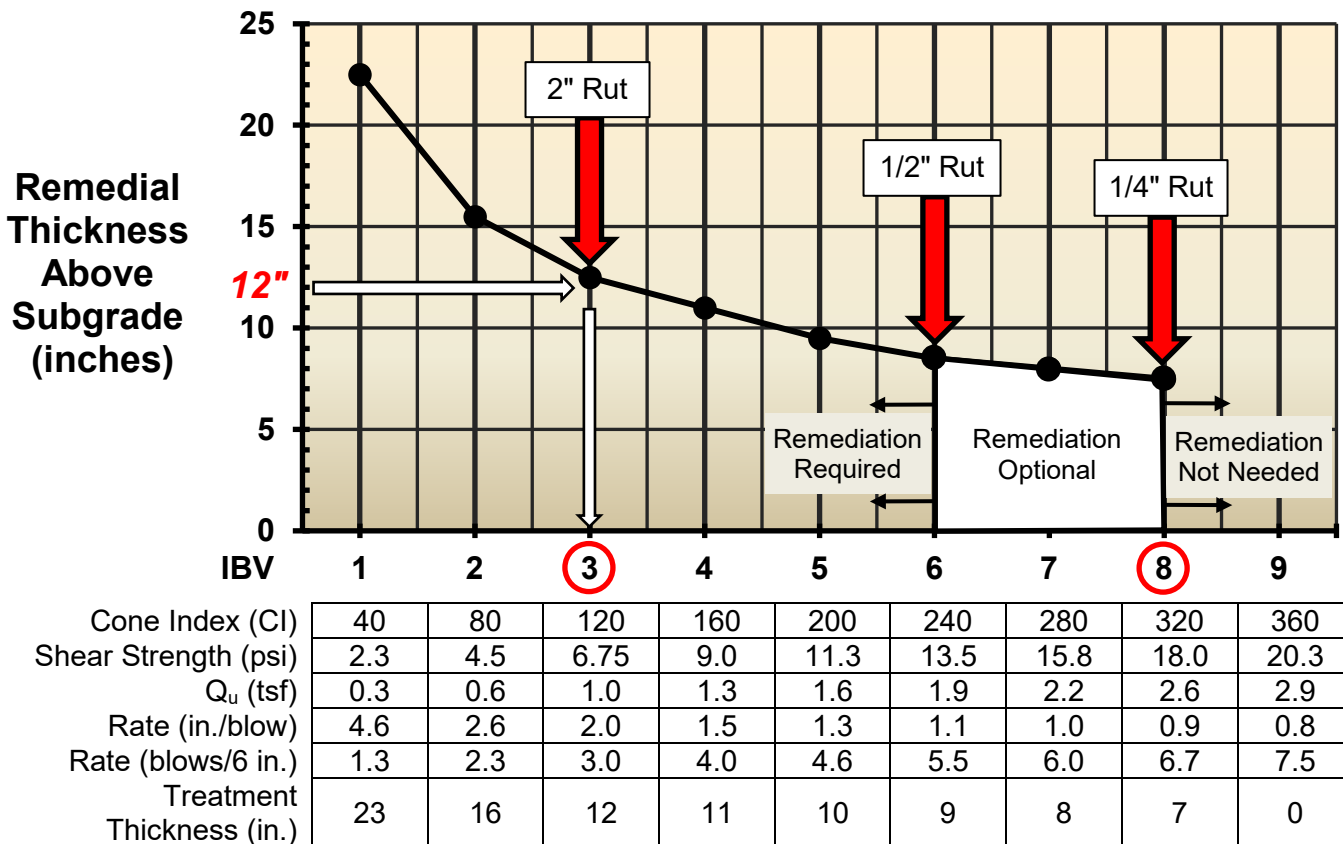

Figure 17. Graph illustrating typical rut depth under construction traffic as a function of IBV, Cone Index (CI), Shear Strength, and Q<sub>u</sub> for subgrade treatment.

#### 7.2 Treatment Types

An Improved Subgrade is constructed to provide a stable base for the pavement construction and mitigate problem areas in the subgrade. The Improved Subgrade typically consists of a 12 inch layer of chemically modified soil or an aggregate. Soil modification is usually used in rural areas, and aggregate is usually used in urban areas or on small sections. With the exception of recycled concrete, consult the Geotechnical Engineer prior to incorporating recycled or reclaimed materials into the subgrade.

The plans should include corrective actions for locations where the typical 12 inch Improved Subgrade is not adequate or where unsuitable materials are identified. These corrective actions could include: deeper soil modification, if feasible; removal and replacement with aggregate; removal and replacement with unrestricted soil; using geosynthetics in conjunction with aggregate; or some combination of options. The most common remedial action is the removal and replacement with aggregate, particularly when the soil is silty. A geosynthetic may be used to reduce the thickness of aggregate needed; however, geosynthetics are most effective for soils with very low IBVs.



### 7.2.1 Soil Modification

Chemically modifying subgrade soils is the most economical method for improving subgrade soils. It is most frequently used in rural areas because the operation can be very dusty. Soils may be chemically modified by mixing with a variety of materials including cement, lime, fly ash, or bituminous materials. The selection of the type of chemical modifier varies by the soil properties. The most common modifier is a by-product of quicklime production called lime kiln dust (Article 1012.03). Successful lime modification mainly depends on the following five factors:

1. The subgrade soil has a minimum clay content of 15%, per Article 1009.01 of the Standard Specifications. On cut or at-grade sections, the plans will indicate alternative treatments for areas not meeting this requirement. The limits shown on the plans are approximate and should be confirmed by the Inspector. For embankment sections, a special provision outlining the requirements for embankment soil should be included in the contract. The requirements should also specify the clay content limit for the top two feet of the embankment.
2. The subgrade soil beneath the lime modified layer must have a minimum IBV of 3. At lower bearing values, additional remedial action may be necessary.
3. The lime kiln dust must be distributed uniformly over the area to be modified.
4. The lime kiln dust must be homogeneously processed. There should be no large clumps of soil or pockets of lime following processing.
5. A sufficient amount of water must be present for the lime-soil reaction to take place. The quantity of water shown on the plans is an estimate. The amount of water needed depends on the field conditions at the time of modification. Having too much water is not as big a concern as not having enough. A quick check for adequate moisture can be made by picking up a handful of material immediately behind the processor and squeezing it. If it crumbles easily, more water needs to be added. The moisture content is probably adequate if, after squeezing, the material can be manipulated without crumbling.

Mix designs are not typically developed prior to construction because the source of lime is not known until the contractor identifies one for sampling. Soil samples and lime samples shall be submitted for mix design at least 45 days prior to construction according to Article 302.04 of the standard specifications.

For situations where the soil does not contain 15% clay or a lime design is not available for the subgrade soil, contact the Geotechnical Engineer for assistance.

For Project Procedures Guide sampling requirements, refer to Appendix B.

For the other materials available that can be effective for subgrade modification, the two primary alternatives are slag cement and Class C fly ash. These materials would generally be used where the subgrade soil has a clay content less than 15% and subgrade replacement with aggregate would be cost prohibitive. Section 302 of the Standard Specifications addresses soil modification with lime and other alternative materials. If subgrade modification is proposed during design, the plans will indicate the limits of treatment and include a Special Provision describing the method of construction. If a Contractor proposes subgrade modification, in lieu of aggregate required on the plans, contact the Geotechnical Engineer.



### 7.2.2 Granular Improved Subgrades

The project plans may call for a granular improved subgrade through a variety of pay items and thicknesses. The most common pay items include *Aggregate Subgrade Improvement*, *Subbase Granular Material* (Type A or B), and *Aggregate Base Course* (Type A or B). Each pay item allows for use of specific course aggregate gradations. Where the gradation CA 6 is used, the thickness should not exceed 9 to 12 inches (depending on the locally available materials) as it may become internally unstable, particularly with rounded natural gravels.

### 7.2.3 Removal and Replacement

Subgrade treatment requiring thicknesses greater than 12 inches are common where it is necessary to remove the unsuitable/untreatable soil and replacing it. Removal and replacement is the most common type of treatment in silty soils. Replacement materials may be an unrestricted soil or an aggregate. When aggregate is used for replacement, it is common to use *Aggregate Subgrade Improvement* or *Rockfill*. In the absence of a Special Provision, the *Aggregate Subgrade Improvement* should be according to gradations recommended in Table 4 as defined in the BDE Special Provision for *Aggregate Subgrade Improvement*. The *Aggregate Subgrade Improvement* is typically capped with 3 inches of CA 6, CA 10, or RAP, unless otherwise specified. RAP may only be used as capping aggregate in the top 3 in. (75 mm) when aggregate gradations CS 01, CS 02, or RR 01 are used in lower lifts; and it must have 100 percent passing the 1 1/2 in. (37.5 mm) sieve, be well graded, and follow the current Bureau of Materials and Physical Research Policy Memorandum, "Reclaimed Asphalt Pavement (RAP) for Aggregate Applications". Some Districts may specify a CA 7 or CA 11 capping material as well.

**Table 4. Aggregate Subgrade Improvement Gradations.**

<b>Aggregate Subgrade Thickness (ft)</b>	<b>Aggregate Subgrade Gradation</b>
≤1	CA 2, CA 6, CA 10, or CS 01
1 to 2	CS01, CS02, or RR 01 (see Article 1005.01(c))
> 2	Contact Geotechnical Engineer

COARSE AGGREGATE SUBGRADE GRADATIONS					
Grad No.	Sieve Size and Percent Passing				
	8"	6"	4"	2"	#4
CS 01	100	97 ± 3	90 ± 10	45 ± 25	20 ± 20
CS 02		100	80 ± 10	25 ± 15	

### 7.3 Identifying Subgrade Problems

Subgrade problems can include the presence of unsuitable materials or locations where the typical 12 inch Improved Subgrade does not provide adequate support. The plans should indicate areas requiring additional subgrade treatment that were identified in the projects geotechnical report. Limits of these areas are approximate and must be evaluated in the field by the Inspector. The Inspector should visually verify that the soil in the field is consistent with the soil described in the project's geotechnical report for subgrade areas needing treatment.



### **Visually verify that soils described in the Geotechnical Report are consistent with the field soils.**

Problems with unsuitable or unstable materials usually occur in cuts or at-grade. Subgrade stability problems may also occur on shallow embankments when the embankment is placed on unstable material. Subgrade soils should consist of unrestricted materials; with the exception of granular soils, materials classified as restricted in Table 7 are considered unsuitable subgrade soils. Granular soils usually require confinement with larger aggregate (e.g., CA 6) to achieve stability under construction traffic.

The Inspector must visually observe the performance of the subgrade prior to treatment. If one or more of the conditions below is encountered, the routine 12 inch Improved Subgrade may not provide adequate stability:

1. The untreated subgrade in cut or at-grade sections is wet and will not achieve density after following the steps outlined in Article 301.04.
2. The untreated subgrade ruts more than 2 inches under heavy equipment (field tests have shown that subgrades with IBV of 3 give an average rut depth of 2 in.).
3. The untreated subgrade pumps or rolls under heavy equipment.

There are a couple of methods which Inspectors use for evaluating subgrades. One method often utilized is proof rolling. This consists of driving a fully loaded truck or heavy construction equipment over the subgrade and observing rutting or pumping (Figure 18). In some cases, proof rolling may be specifically included in the contract as a Special Provision. In general, the Inspector should always observe the performance of the subgrade during construction. Prior to Improved Subgrade construction, the subgrade is often used as a haul road unless prohibited by Special Provision. This gives field personnel a good opportunity to check subgrade conditions. Also, excessive moisture could have adverse effects on the density and stability (IBV) of both clayey and silty soils; however, its effect is more significant



**Figure 18. Photos of rutting (a) and pumping (b) under proof rolling or construction traffic.**

on silty soils as shown in Figure 19. Note that for silts, the IBV drops dramatically past optimum, whereas for clays, the decrease is more gradual in Figure 19.

A second inspection method is the determination of the in-place IBV of unstable subgrades with a cone penetrometer; either the SCP or the DCP. The IBV data from these tests is used to evaluate the in-place stability of the subgrade and determine the extent of any remedial action required. When obtained in the field using a DCP or SCP, the IBV is considered equivalent to the field California Bearing Ratio (CBR) test (ASTM D 4429). When evaluating the suitability of subgrade improvement, the IBV data directly below the estimated depth of subgrade improvement should be used. In general, the IBV data between a depth of 12 and 30 inches should be used to evaluate the adequacy of a 12 inch Improved Subgrade.

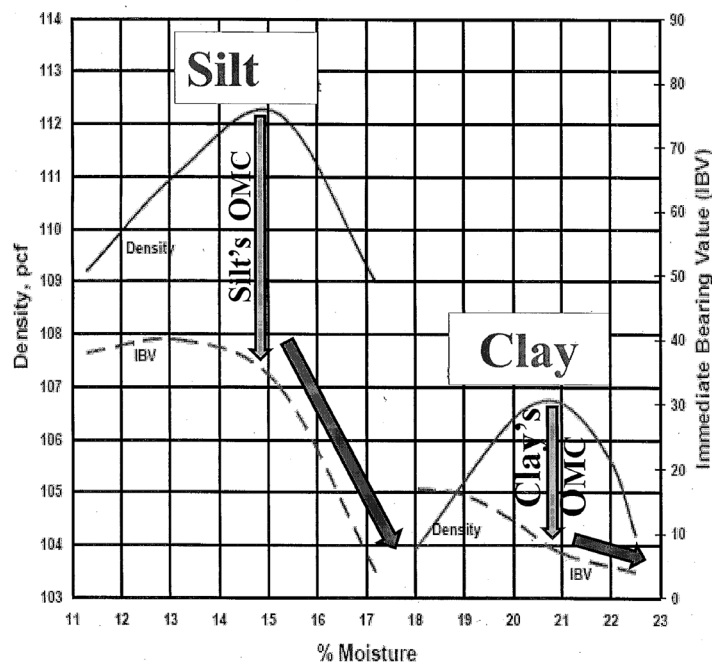

**Figure 19. Graph illustrating the effect of moisture content on IBV.**

In addition to conducting tests, the subgrade soil should be described as per Section 2. The DCP or SCP may not provide an accurate measure of IBV in silty soils. Silty soils must be “proof rolled” using construction equipment immediately prior to testing. Proof rolling commonly locates moisture sensitive soils. Silty soils must be identified in the field, not only for stability, but also to determine their frost susceptibility. The frost penetration depth varies from 4 feet in the northern third of the state to 2 feet in the southern third of the state. The Department uses three criteria according to the Geotechnical Manual to determine if a soil is frost susceptible:

1. The level of capillary rise is within the depth of frost penetration.
2. The soil contains  $\geq 65\%$  silt and fine sand determined by AASHTO T 88.
3. The plasticity index (PI) is less than 12.

Upon identifying a silty soil in the field, the Inspector should typically recommend removal of the soil and replacement with unrestricted materials or suitable aggregate. Frost susceptible conditions are commonly found in shallow cuts or at-grade sections.

#### 7.4 Determining Treatment Thickness

The depth of treatment should be based on the DCP or SCP test data and may also depend on the thickness of any unsuitable or frost susceptible material. Unsuitable materials should be removed to a depth of 2 feet below the top of proposed subgrade. Frost susceptible materials should be removed to a depth equal to the frost penetration depth at that location. For unstable materials, the total thickness of improved subgrade required for different IBVs is shown in Table 5. Furthermore, guidelines for aggregate thickness reductions using geosynthetics is shown in Table 6.

**Table 5. Improved Subgrade Thickness Requirements.**

DCP (in./blow)	SCP (psi)	IBV*	Improved Subgrade Thickness (in.)
< 2	> 120	> 3	12
2.8	80	2	18
4.6	40	1	24
> 4.6	< 40	< 1 (Contact Geotechnical Engineer)	n/a

\*IBV of the subgrade beneath the assumed improved layer.

**Table 6. Guideline for Aggregate Thickness Reduction Using Geosynthetics.**

(From Table 3 in the IDOT Subgrade Stability Manual)

IBV / CI	Aggregate Cover without Geosynthetics in. (mm)	Aggregate Cover with Geosynthetics in. (mm)	Aggregate Cover with Geogrid in. (mm)
1 / 40	22 (560)	16 (450)	15 (375)
1.5 / 60	18 (450)	12 (300)	12 (300)
2 / 80	16 (400)	12 (300)	10 (250)
3 / 120	12 (300)	12 (300)	9 (230)

If the penetration rate of the DCP is greater than 6 inches per blow (IBV < 0.7), the required thickness of Improved Subgrade exceeds 24 inches. In these cases, the Geotechnical Engineer must be contacted to better evaluate the field conditions.

In addition to Table 5, Figure 20 shows thickness design as a function of IBV, Cone Index (CI), Shear Strength, and unconfined compressive strength ( $Q_u$ ) for subgrade treatment (using granular backfill or modified soil). Inspectors are advised to understand how to use the figure, as well as have a copy of it available with them in the field to be readily used.

In order to not cause construction delays, it is very important that the Inspector becomes familiar with the method/procedure of determining the treatment thickness in the field, especially when more frequent testing is needed. To fully understand the process, a class problem has been prepared with four different scenarios, in which the first has been completed as an example.

### IBV BASED REMEDIAL ACTION

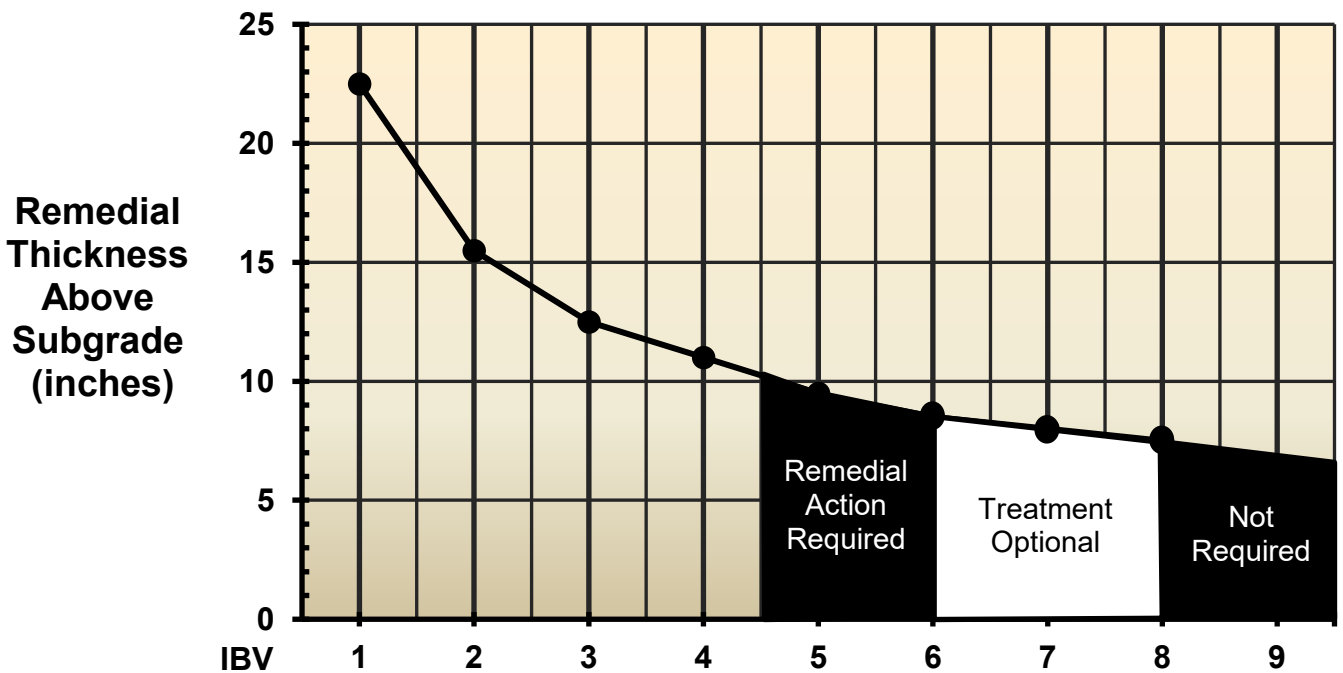

Cone Index (CI)	40	80	120	160	200	240	280	320	360
Shear Strength (psi)	2.25	4.50	6.75	9.00	11.25	13.50	15.75	18.00	20.25
$Q_u$ (tsf)	0.32	0.64	1.00	1.28	1.60	1.94	2.24	2.56	2.88
Rate (in./blow)	4.6	2.6	2.0	1.5	1.3	1.1	1.0	0.9	0.8
Rate (blows/6 in.)	1.3	2.3	3.0	4.0	4.6	5.5	6.0	6.7	7.5
Treatment Thickness (in.)	22.5	15.5	12.5	11	9.5	8.5	8	7.5	0

Figure 20. Graph and table for thickness design as a function of IBV, Cone Index (CI), Shear Strength, and  $Q_u$  for subgrade treatment.

**CLASS PROBLEM 6: Determine the required subgrade treatment thickness for the four scenarios shown in the table on page 41. The first scenario has been done for you.**

**Solution Process:** For each of the four scenarios, follow these steps:

1. The contractor completes rough grading. The rough grade is the surface of the untreated subgrade. Then, when plans call for an untreated subgrade or a granular layer(s), prepare the rough graded soil subgrade according to Article 301.04 of the Standard Specifications by disking, drying, and compacting. Then, perform steps 2 thru 7 below.

When plans call for Soil Modification, perform steps 2 thru 7 below in suspected weak spots prior to soil modification and adjust the thickness in those localized areas. Perform the soil modification and repeat steps 2 thru 7 below to verify and remediate as needed.

2. Conduct proof rolling and DCP (or SCP) testing at representative locations (preferably rut locations). Identify the length(s) and width(s) including stations and offsets of any weak subgrades locations requiring further treatment.
3. Determine the IBV (or CI) at the following depth intervals:
  - a. 0 – 6 in.
  - b. 6 – 12 in.
  - c. 12 – 18 in.
  - d. 18 – 24 in.
  - e. 24 – 30 in.
4. Check IBV (or CI) within 18 inches below the bottom of the Improved Subgrade. The following Case 1 and Case 2 illustrate rough graded subgrade in cut, at-grade, and fill conditions for aggregate, modified soil, and untreated conditions:

*Case 1—Aggregate Subgrade*

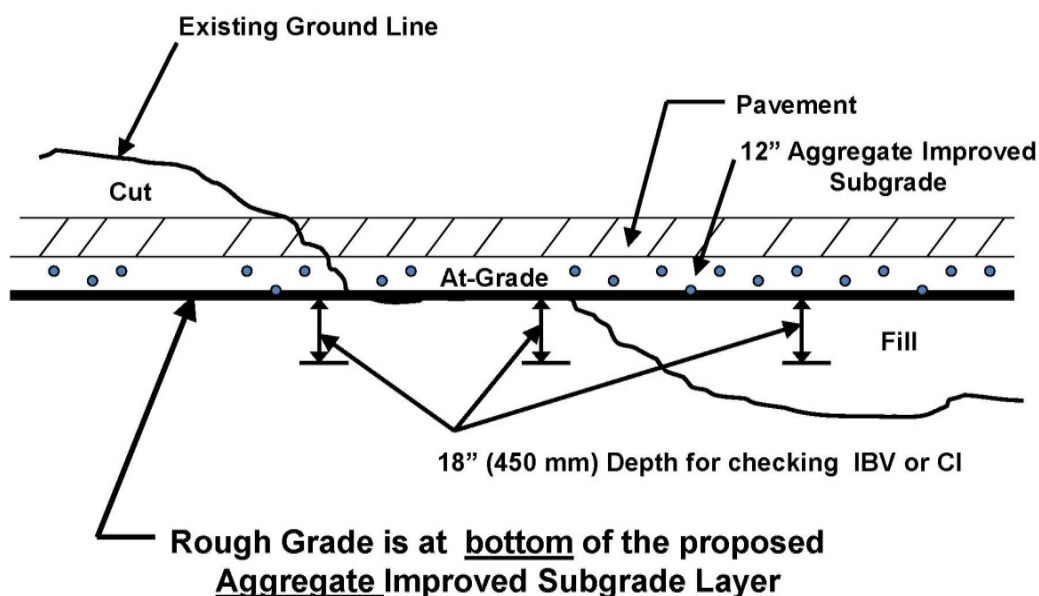

## Case 2—Modified or Untreated Subgrade

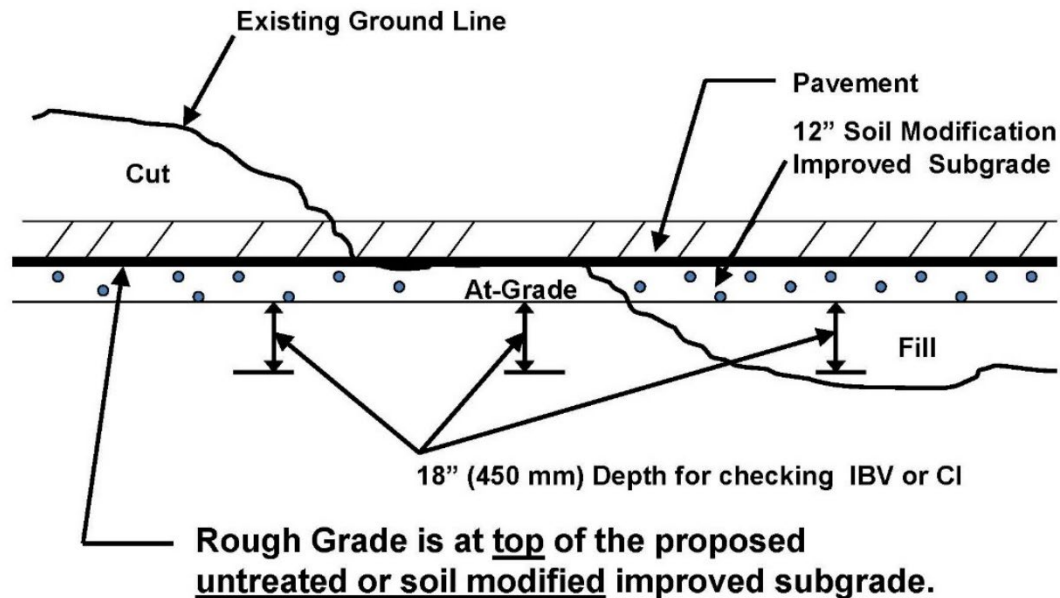

5. Use Figure 20 to determine the required treatment thickness based on IBV (or CI) for each depth interval. Call this "Required Cover". Record this in the table on Page 41.
6. Compare this "Required Cover" with the "Available Cover". "Available Cover" is the Depth Interval Increment plus 12 inches, assuming an Improved Subgrade plan thickness of 12 inches. Determine the amount of Additional Cover Required.
7. Determine the Total Required Treatment Thickness. The total required treatment thickness is equal to any additional cover required plus the already treated 12 inches of Improved Subgrade.

**SCENARIO 1:**

Steps 1 – 3: Completed per above.

Step 4: See the IBV (or CI) test results within 18 inches below the bottom of Improved Subgrade, which are recorded under the column "Observed IBV" in the table on Page 41. The IBV and CI values are given as follows:

Depth (in.)	IBV / CI
0 – 6	3 / 120
6 – 12	2 / 80
12 – 18	1 / 40

Step 5: Using Figure 20, determine the "Required Cover" for each depth interval and record it under the column "Required Cover" in the table on Page 41.



### IBV BASED REMEDIAL ACTION

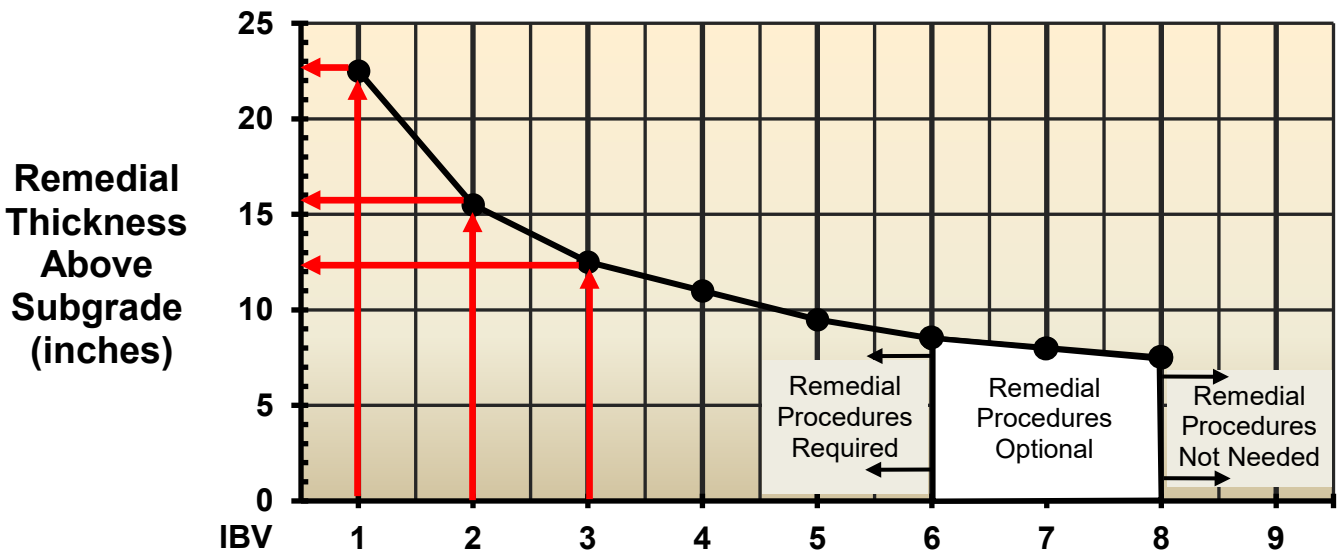

Cone Index (CI)	40	80	120	160	200	240	280	320	360
Shear Strength (psi)	2.3	4.5	6.75	9.0	11.3	13.5	15.8	18.0	20.3
Q <sub>u</sub> (tsf)	0.3	0.6	1.0	1.3	1.6	1.9	2.2	2.6	2.9
Rate (in./blow)	4.6	2.6	2.0	1.5	1.3	1.1	1.0	0.9	0.8
Rate (blows/6 in.)	1.3	2.3	3.0	4.0	4.6	5.5	6.0	6.7	7.5
Treatment Thickness (in.)	23	16	12	11	10	9	8	7	0

Step 6: Compare the “Required Cover” with the “Available Cover” and determine if any additional cover will be required. Note that the “Available Cover” has already been recorded in the table on Page 41. The amounts of Available Cover are as follows:

Depth (in.)	Depth Interval Increment (in.)	Available Cover (in.)
0 – 6	0	12 + 0 = 12
6 – 12	6	12 + 6 = 18
12 – 18	12	12 + 12 = 24

Tabulate the values for Available Cover and Required Cover, and determine the amount of Additional Cover Required.

Depth (in.)	Available Cover (in.)	Required Cover (in.)	Additional Cover Required (in.)
0 – 6	12	12	0
6 – 12	18	16	0
12 – 18	24	23	0

Since in Scenario 1 the Available Cover is greater than or equal to the Required Cover at each depth interval, no additional cover is required.

Step 7: Determine Total Required Treatment Thickness. The total required treatment thickness is equal to any additional cover required plus the already treated 12 in. of Improved Subgrade.

Thus, for Scenario 1, the Total Required Treatment Thickness =  $0 + 0 + 0 + 12 = 12$  in.

**Scenarios 2, 3, and 4:** Follow the same steps as above and complete the table on Page 41.

CLASS PROBLEM 6 WORKSHEET

Depth Increment Below Bottom of Improved Subgrade <sup>(1)</sup> (inches)	Scenario 1		Scenario 2		Scenario 3		Scenario 4		
	Available Cover on Top <sup>(2)</sup> (inches)	Observed IBV <sup>(3)</sup>	Required Cover <sup>(4)</sup> (inches)	Observed IBV <sup>(3)</sup>	Required Cover <sup>(4)</sup> (inches)	Observed IBV <sup>(3)</sup>	Required Cover <sup>(4)</sup> (inches)	Observed IBV <sup>(3)</sup>	Required Cover <sup>(4)</sup> (inches)
0 - 6	12	3	12	2		1.5		5	
6 - 12	18	2	16	5		4		1	
12 - 18	24	1	23	1		7		1	
<b>Additional Treatment Thickness Required<sup>(5)</sup> (inches)</b>	<b>0</b>								
<b>Total Required Treatment Thickness (inches)</b>	<b>12</b>								

- (1) See Case 1 and 2 in Step 4.
- (2) Assuming a typical 12 inch (300 mm) Improved Subgrade.
- (3) For the corresponding 6 inch (150 mm) increment.
- (4) From Figure 20, round up to the nearest inch, or follow District practice.
- (5) Confirm by proof rolling and consult with the Geotechnical Engineer.

## 8. EMBANKMENT INSPECTION

Embankment has a variety of uses, including new alignment fill sections, embankment widening, grade raises, wall backfill, and bridge cones and approaches as illustrated in Figure 21.

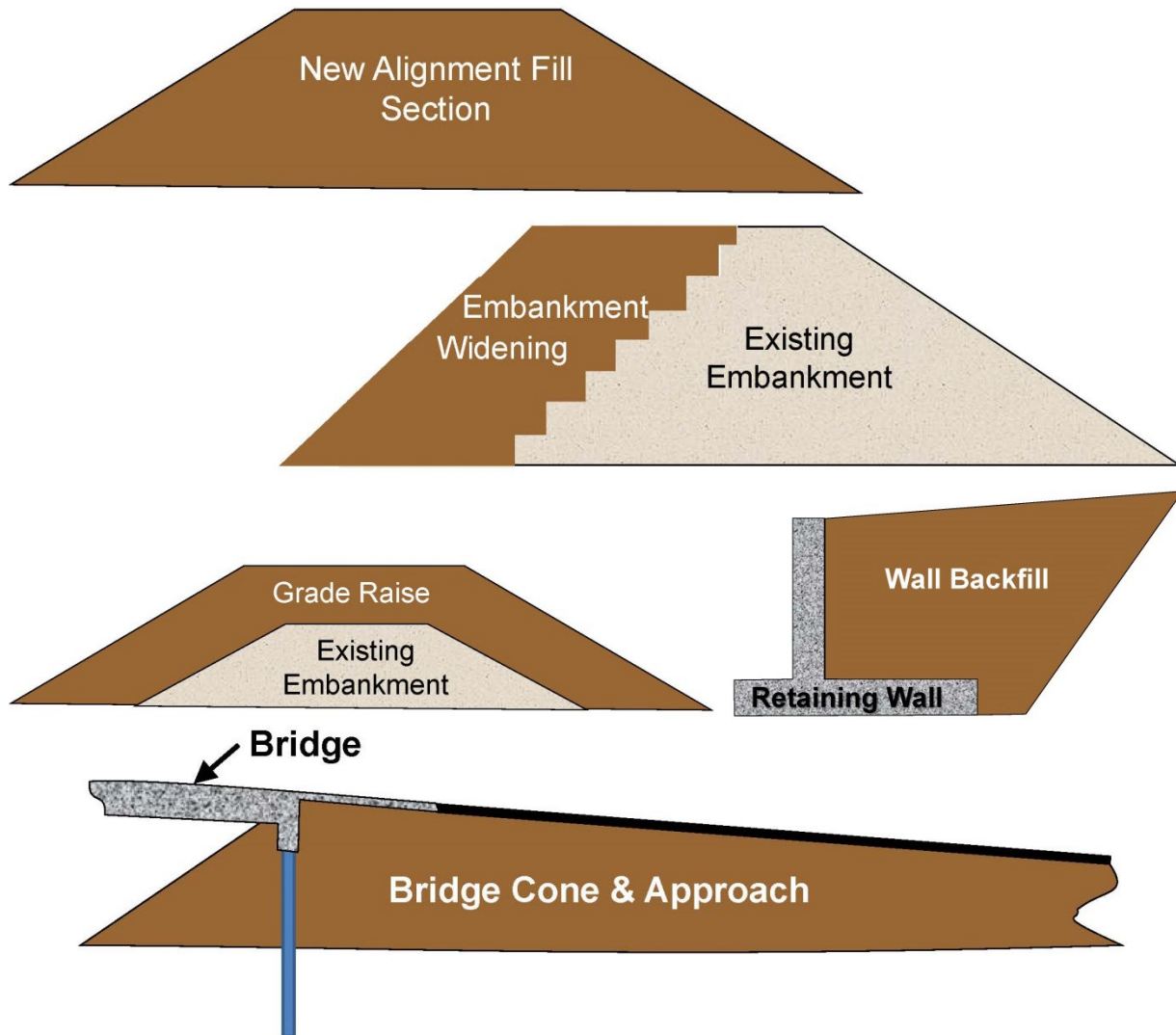

**Figure 21. Illustrations of types of embankment construction.**

Inspection of embankments includes the following:

- Ground preparation and stability
- Material acceptability
- Placement and compaction
- Performance problems

## 8.1 Ground Preparation and Stability

The existing ground should be cleared of all vegetation as described in Section 201 of the Standard Specifications. Vegetation contains organic material that can later cause settlement or stability problems. Any topsoil that is required to be salvaged shall be removed and stockpiled according to Article 211.03 (the stockpiled soil may be reused on the surface or on another IDOT project).

Preparation of the existing ground surface, which shall be according to Article 205.03, will depend on the existing ground conditions. Unsuitable or unstable embankment foundation conditions should typically be identified in the Geotechnical Report, along with the appropriate remedial action. Prior to placing new embankment material, any unsuitable or unstable areas at the ground surface shall be removed or treated. These conditions include the presence of poorly drained, weak soils, areas of standing water, old channels, and the presence of organic material.

In some cases, the problem may be more or less extensive than the plans indicate. The Inspector may make independent adjustments based on actual field conditions or can request that the Geotechnical Engineer evaluate the conditions and make recommendations. The Geotechnical Engineer must be contacted if difficult conditions are encountered that are not shown on the plans.

The existing ground surface may either be flat or sloping. For flat surfaces, the minimum necessary preparation prior to embankment construction consists of the existing ground being disked to a depth of 6 inches and compacted as stated in Article 205.03, in order to support compaction of the first lifts. If there is existing pavement at or under the existing surface, and unless the plans call for a deviation, preparation shall involve the following (also see Figure 22):

- If Embank Cover > 3 ft. Leave existing pavement in place
- If Embank Cover < 3 ft. & > 3 in. Break existing pavement & leave in place
- If Embank Cover < 3 in. Remove existing pavement

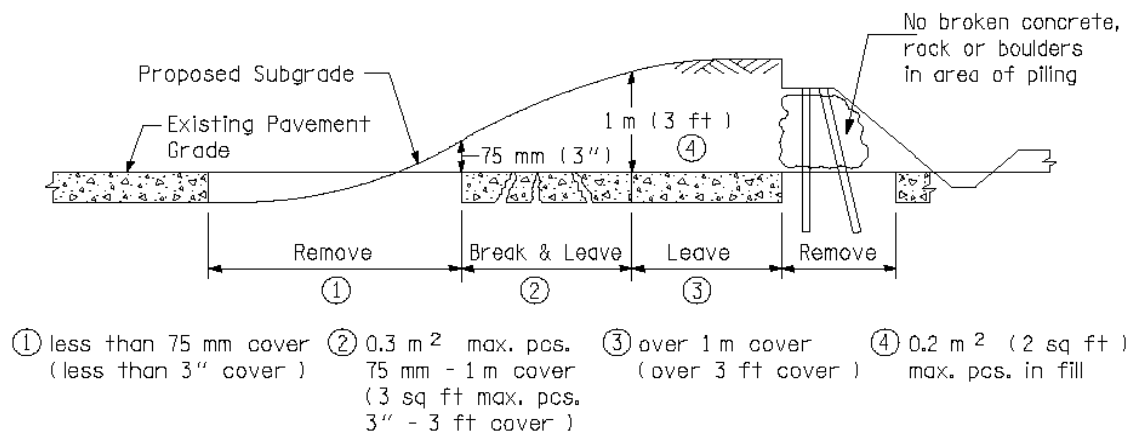

**Figure 22. Illustration of embankments constructed over existing pavement.**

For existing sloped surfaces, the minimum necessary ground preparation must involve either “deep plowing” or “stepping and benching,” in order to connect the new embankment to the existing and to ensure slope stability. For slopes at 1V:3H (vertical:horizontal) and steeper, “stepping and benching” will be necessary as detailed in the plans or as directed by the Engineer.

Ground preparation may require additional treatment in addition to the minimum preparation requirements discussed above. To determine if additional treatment will be required, the Inspector should:

- Check the contract plans and Special Provisions
- Check the Roadway Geotechnical Report
- Inspect field foundation soils

The contract plans and Special Provisions should be checked for any undercut limits, depths, and pay items. The Roadway Geotechnical Report should be checked for any specific treatment limits and depths. In addition to checking documents, field foundation soils should be inspected by both visual means and field testing in order to determine if additional testing will be required. Visual inspection will involve verification that soil types assumed in the Geotechnical Report are consistent with the field soils.

**When the field treatment limits and/or depths differ from those indicated in the plans or the Geotechnical Report, the actual treatment limits and depths will need to be adjusted to the field determined values.**

**When the contract plans or Geotechnical Report does not specify any treatment at a section, the Inspector needs to: 1) determine treatment limits and depth(s), and 2) discuss ground treatment options with the Field Engineer or Geotechnical Engineer.**

The Inspector should observe the soil behavior in the field for excessive rutting under wheel loads (this applies to subgrades under pavement), pumping, and formation of “silt volcanoes”. Wet, poorly drained clayey soil areas can also warn of problems. The most important purpose of the visual inspection is to identify any “problem” soils. Once problem locations have been identified, DCP or SCP testing will help determine the extent of treatment. If the DCP indicates > 3 blows per 6 inches (IBV > 3) or the SCP shows CI > 120, 6-in. disking and compaction should be satisfactory to achieve the density and stability requirements, otherwise treatment will need to be considered.

Required treatment for problem soils may consist of:

- Mixing in dry clayey soils (for silts and clays)
  - Can be time consuming
- Removal and replacement (for silts and clays)
  - Replace with suitable borrow soils or coarse aggregate, with or without fabric
  - Less time consuming than mixing in dry clayey soil
- Disking and drying, if wet (for silts)
  - To limit moisture (100-105% OMC)
  - Can be too time consuming
- Mix in lime or fly ash (for clays)
  - Mix 0.5-1% lime or fly ash to act as a drying agent

Drying agents help reduce the moisture for foundation soils that are wet of optimum. As previously mentioned, for silts, the IBV drops dramatically past optimum (as shown in Figure 19), whereas for clays, the decrease is more gradual.

## 8.2 Material Acceptability

Embankment inspection, as covered in this course, focuses on evaluating and approving soils used for embankments. The acceptability of such material will need to be determined by the Inspector (with the assistance of the Geotechnical Engineer if need be). Sources of embankment material may consist of the following:

- Earth excavation
- Furnished excavation
- Borrow excavation
- Quarried rock
- Recycled concrete

Earth excavation is soil cut directly from the site, whereas furnished excavation and borrow excavation consists of soils obtained off site. Typically, the Contractor is responsible for selecting the borrow source. IDOT will sample and test the material for acceptability; to aid in this, the Department may obtain quality assurance (QA) borings. The Geotechnical Report should also be checked to determine if any possible sites were identified or QA borings were provided. On projects where there is a large quantity of excavated material that will be used in fill areas, the Geotechnical Report should include classification data and moisture-density relationships for soils identified as possible borrow sources. This information is usually referenced on the Roadway Geotechnical Report's Soil Profile. However, restricted use materials may not be identified in the Geotechnical Report.

When borrow or furnished excavation materials are inspected and tested, the Geotechnical Engineer will provide the moisture-density relationships for those soils. The Geotechnical Report may also contain a project-specific family of curves when large quantities of materials are excavated from within the project limits. In situations where a complete moisture-density relationship has not been developed, the one-point method and family of curves (Illinois Modified AASHTO T 272) may be used. Some Districts have developed a District-specific family of curves.

Article 1009.04 of the 2022 publication of the Standard Specifications designates soils which certain properties as suitable, restricted-use, unsuitable. These soils may also be designated as either stable or unstable. These designations are initially assessed through visual inspection and verified through testing at the discretion of the Engineer. Soils meeting suitable and restricted-use categories may be used for embankments, fills, and subgrades.



To determine which category a soils falls under, the following is generally carried out:

- Excavated borrow or furnished soils are sampled
  - Visually identified
  - Run Standard or 1-Point Proctor test
  - Obtain SDD & OMC
- Verify requirements of the Standard Specifications (Article 1009.04) shown in Table 7
- Check plans, Special Provisions, or Geotechnical Report for other requirements
  - Plasticity Index (PI), Liquid Limit (LL), gradation, shrinkage factor, and restricted use soils

**Table 7. Suitable and restricted-use soil property limits (Article 1009.04).**

Test	Suitable Soil	Restricted-Use Soil
Standard Dry Density at Optimum Moisture Content (OMC), (Illinois Modified AASHTO T 99 – Method C & Annex A1), lb/cu ft	90 min.	90 min.
Organic Content, (AASHTO T 194), %	10 max.	10 max.
Passing No. 200 Sieve, %	–	35 max.
Silt and Fine Sand, (AASHTO T 88), %M	65 max.	–
Plasticity Index, (AASHTO T 90), %	12 min.	–
Liquid Limit, (AASHTO T 89), %	50 max.	60 max.

Soils are checked by the tests in Table 7 for problematic properties. These may include (also see Table 8):

- Any Soils with LL > 50
  - Shrink/swell problems
- Soil with PI < 12 and > 65% silt and fine sand
  - Erodible and frost susceptible
- Sand, sandy loam or shale
  - Sand is erodible; shale is degradable/erodible too

There are some materials that are problematic when used in embankments. Problematic materials may consist of organic materials, materials with the potential of excessive volume change, and materials susceptible to erosion or frost action such as silts, which are also not suitable for lime modification. In embankments, soils are usually above capillary rise, and frost heave is less likely than in cut sections. However, frost heave beneath pavements or shoulders can still occur in embankments due to the infiltration of surface water, combined with poor drainage and presence of frost susceptible subgrade soils. When borrow or furnished excavation is proposed to be used, the Geotechnical Engineer will evaluate the material and identify applicable restrictions as part of the approval process. When an embankment is constructed of significant quantities of earth excavation, the soil profile and classification test results should also be typically available in the Geotechnical Report to help identify the location of problematic materials. Table 8 identifies problematic materials. Restrictions vary throughout the state; therefore, the Geotechnical Engineer must be contacted for District-specific questions.

**Table 8 Problematic embankment construction materials.**

Material	Restriction	Reason
Soil with an organic content > 10%	Not Allowed Article 1009.04	Usually low strength; subject to decomposition, causing settlement.
Soil with standard dry density < 90 pcf	Not Allowed Article 1009.04	Indicative of organic soil; may not achieve the minimum compressive strength assumed for fills.
Soil with clay content < 15% (loam, silt loam, and silt)	Consult Geotechnical Engineer Articles 1009.01 & 1009.02	Soils with minimum 15% clay will normally react sufficiently with lime.
Granular soils (sand and sand loam)	Consult Geotechnical Engineer	Granular soils are highly erodible.
Soil with plasticity index < 12 (excluding granular soils)	Consult Geotechnical Engineer	Soils with PI < 12 are usually highly erodible and may be frost susceptible in subgrades.
Soil with liquid limit > 50%	Consult Geotechnical Engineer	Potential for volume change (shrink/swell) with changes in moisture content.
Clean construction material debris and Reclaimed Asphalt Pavement (RAP)	According to Article 1009.04	Aesthetic and environmental restrictions.
Shale and Rockfill	Consult Geotechnical Engineer	Shale deteriorates when exposed to weathering. Rockfill is capped for aesthetic reasons.

When a problematic material is identified during inspection of embankment construction materials, the Geotechnical Engineer will describe the specific restriction based on project specific conditions. When a borrow or furnished excavation source includes both restricted and suitable (unrestricted) materials, the materials may be mixed upon approval of the Geotechnical Engineer. If the resulting mixture satisfies the requirements for suitable (unrestricted) soil, then it may be used as such.

Article 1009.04 also provides for other materials which may be used for embankment material as restricted-use including:

- Stones and boulders naturally occurring within the right of way
- Broken concrete without protruding metal bars
- Bricks, rock, and stone
- Recycled asphalt pavement (RAP) according to Article 1031.01 with no expansive aggregate
- Uncontaminated dirt and sand generated from construction or demolition activities
- Other materials if approved by the Engineer

In addition, Article 205.04 requires embankment material to be limited to:

- No frozen or decay prone materials
- No concrete pieces > 2 ft<sup>2</sup> (distribute uniformly and fill voids)
- Rocks, boulders, and other similar restricted-use miscellaneous materials may also be used provided they are distributed uniformly and fill voids.

### 8.3 Placement and Compaction

#### 8.3.1 Placement of Material

According to Article 205.04, soils should be placed with a maximum of 8-in. loose (uncompacted) lift thickness. Lifts of suitable material shall be placed uniformly over entire length and width where practical. If restricted materials (e.g., shale, sand, silty soil) are allowed, they should be limited to the embankment core and encapsulated by suitable soil a minimum of 2 ft, measured vertically and horizontally from each face of the in-place restricted-use materials (also see Figure 23).

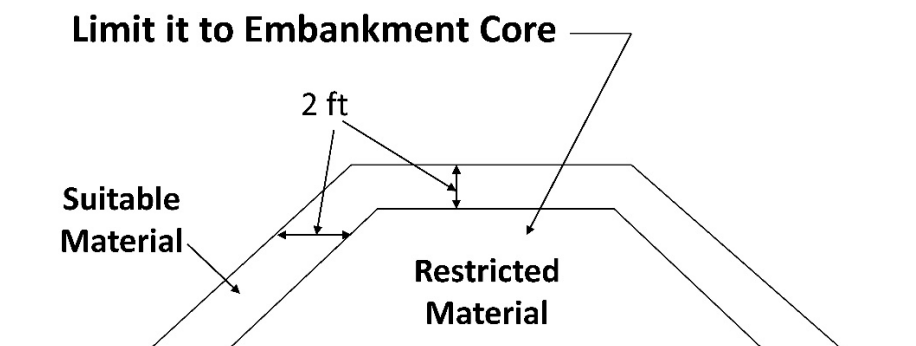

**Figure 23. Illustration of use of restricted material in embankment.**

Placing fill on existing slopes can be a major cause of slope failures. Proper ground surface preparation and placement of the fill is important to constructing a stable fill on a slope. According to Article 205.03 of the Standard Specifications:

“When embankments are to be constructed on hillsides or slopes, or if existing embankments are to be widened or included in new embankments, the existing slopes shall be plowed deeply. When hillsides, slopes, or existing embankments are equal to or steeper than 1:3 (V:H), steps shall be keyed into the existing slopes by stepping and benching before construction of the embankment is started as detailed in the plans or as directed by the Engineer.”

Past practice was to perform stepping and benching when material is placed on a slope that is steeper than 1:3 (V:H) with heights equal to or greater than 15 feet. With revisions in the 2022 Standard Specifications for Road and Bridge Construction, proper stepping and benching now apply to all embankment heights where material is to be placed against existing slope equal to or steeper than 1:3 (V:H), as is practical.

Best practice for compaction of material on benches necessitates that a bench is wide enough for the equipment to work on a relatively horizontal surface for placing and compacting material. Over-building the outer edge of the benches by about 1 to 2 feet and blading off the excess material after compaction also aids in achieving the minimum specified density on the outer edge of the embankment. This over-build technique reduces the chances of surficial sloughing of the material. With the exception of small amounts of fill used to dress the top of slope around guardrail, gutter, or aggregate shoulder, material should never be simply pushed over the side of the embankment. If there are questions regarding this process, contact the Geotechnical Engineer (also see Figure 24).

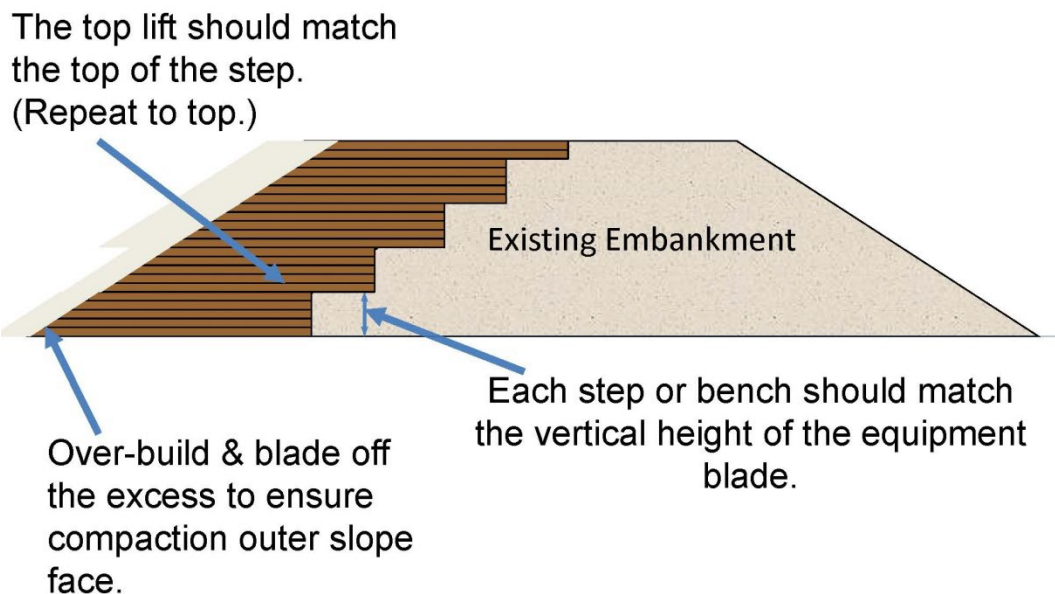

**Figure 24. Illustration of Stepping & Benching Placement.**

If shale is used for embankment material, it shall be placed, broken down, and compacted in the same manner as soil. This may require the addition of water to aid in breaking down the shale. If smaller pieces of concrete, rocks, etc. are used, they are restricted to lifts not exceeding 12 inches in depth as outlined in Article 205.04 of the Standard Specifications.

### 8.3.2 Compaction of Material

Unless otherwise specified in the contract, embankment materials should be compacted according to Article 205.06. Field density and moisture content tests of the embankment are used to document compliance with Department specifications. The dry density of embankments must be equal to or greater than some percentage of the SDD determined in the laboratory. Depending upon the position within the embankment, different values for percent compaction of the SDD are required. An Inspector must check the density of the compacted embankment at regular intervals. Appendix B includes a summary of density testing frequency requirements from the Project Procedures Guide (PPG).

Compaction acceptance shall be according to Article 205.06 of the Standard Specifications. Soils are to be compacted between an 80% minimum to no more than 110% of Optimum Moisture Content. The *minimum* percent compaction shall be between 90% to 95%. Note that the percent compaction will depend on the location within the embankment. Minimum compaction requirements are shown in Figure 25. When the minimum percent compaction is 95%, a minimum IBV of 4.0 is also specified.

Knowledge and proper control of the moisture content is important and essential for successful embankment construction. Some Districts include a Special Provision restricting moisture content to a lower value than what is specified in the Standard Specifications. This information influences the required treatment of a soil prior to compaction. Compacting materials to their specified densities depends on moisture control and the stability of underlying materials. Soils compacted too dry or too wet of optimum may not obtain required density.

If the soil has a moisture content considerably different from the OMC, it will be uneconomical to achieve the desired density by merely continued rolling. If the soil is below the optimum moisture content, additional water can be added and mixed in by blading or disking. If the soil has a water content above optimum, the Contractor must reduce the soil moisture to obtain the desired density, at or near the optimum moisture condition. Soils compacted too wet of optimum may fail to create a stable platform for the successful compaction of successive lifts. To reduce soil moisture, the usual procedure involves disking, to allow for evaporation of water. Some extreme cases have been resolved only by treatment with drying chemicals such as lime or by removal of the excessively wet soil and replacement with a drier soil.

Silty soils are extremely sensitive to moisture content and are generally found wet of optimum. When wet of optimum, they can quickly become unstable during placement and compaction as demonstrated in Figure 19 by the drastic reduction in IBV for silt when wet of optimum. Materials in this condition should be disked and allowed to dry, or mixed with a drier material to lower the moisture content. The Contractor may desire to use a drying agent, at no cost to the Department, to expedite construction, in which case the Geotechnical Engineer should be contacted.



**Case 1:** Fills with a total height less than 1.5 ft.  
Minimum Compaction Specification:

- All lifts 95% or greater.

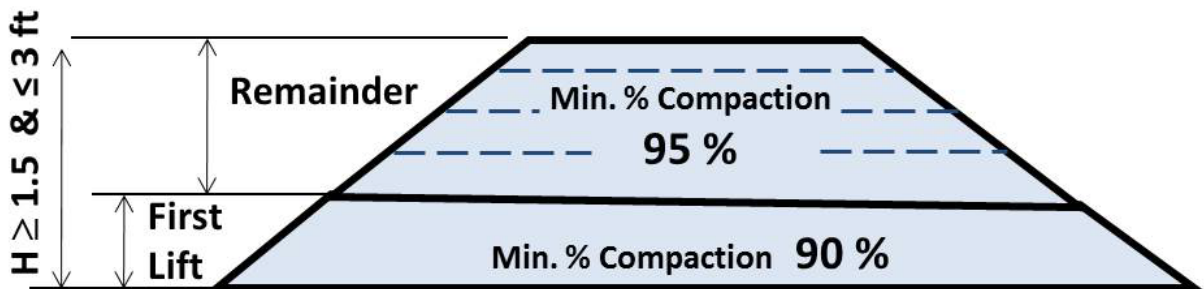

**Case 2:** Fills with a total height from 1.5 ft. to 3 ft.  
Minimum Compaction Specification:

- First (bottom) lift 90%, and
- Remaining lifts 95%.

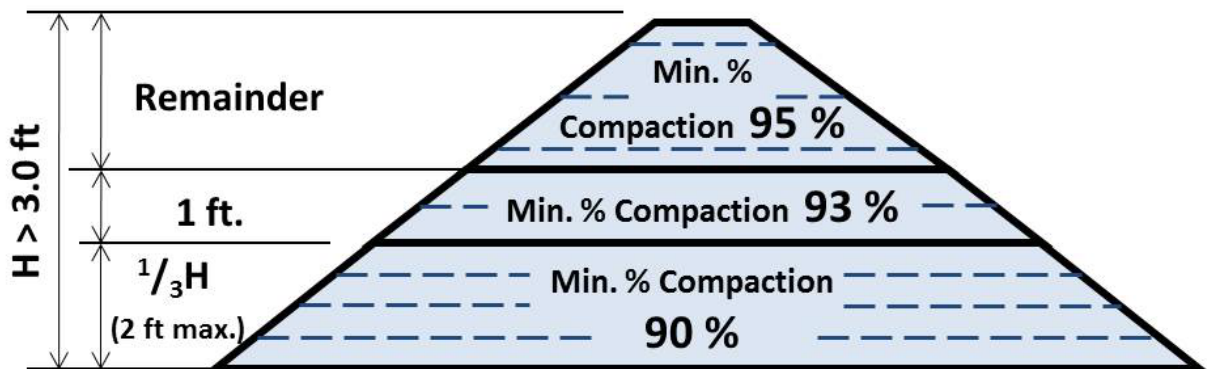

**Case 3:** Fills with a total height greater than 3 ft.  
Minimum Compaction Specification:

- Bottom 1/3 (not to exceed 2 ft. in height) 90%,
- Next 1 ft. 93%, and
- Remaining lifts 95%

**Figure 25. Minimum Percent (%) Compaction Requirements Based on Location in the Embankment.**

**CLASS PROBLEM 7:** Determine the minimum percent compaction requirement at 2.5 ft above the embankment base for each of the given embankment heights.

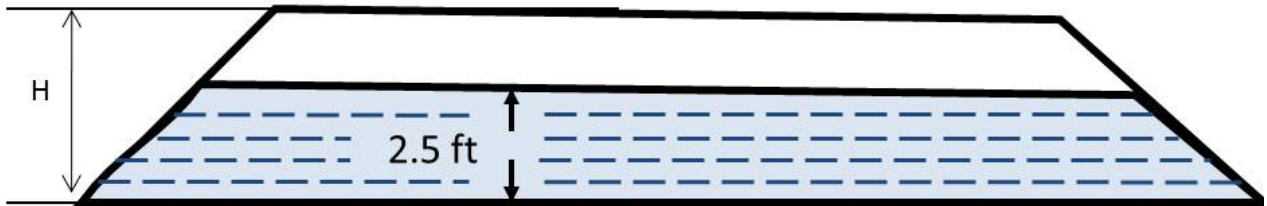

**Scenario 1:** H = 6 ft

**Scenario 2:** H = 3 ft

**Scenario 3:** H = 9 ft

**Solution Process:** Use Figure 25.

**Scenario 1:** 6 ft high embankment

**What is the correct %  
Compaction here**

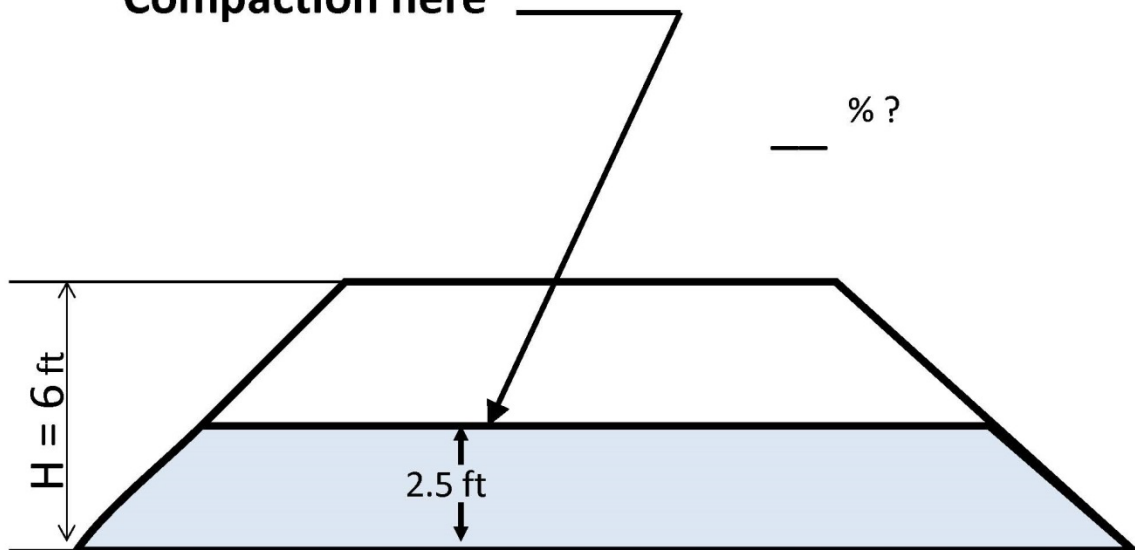



**Scenario 2: 3 ft high embankment**

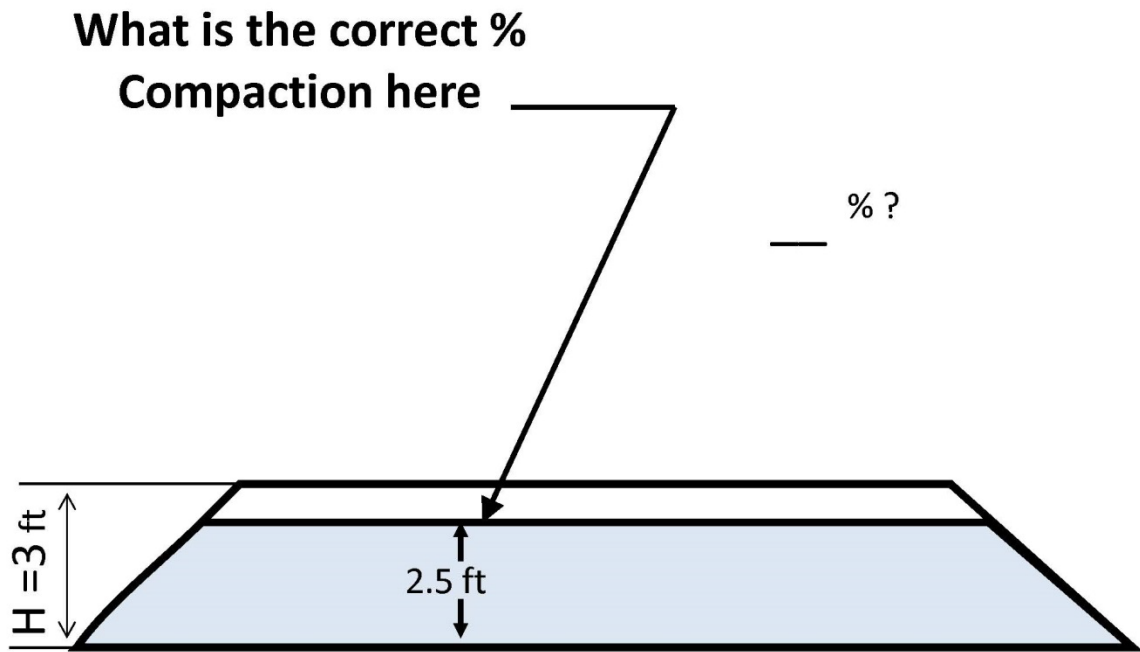

**Scenario 3: 9 ft high embankment**

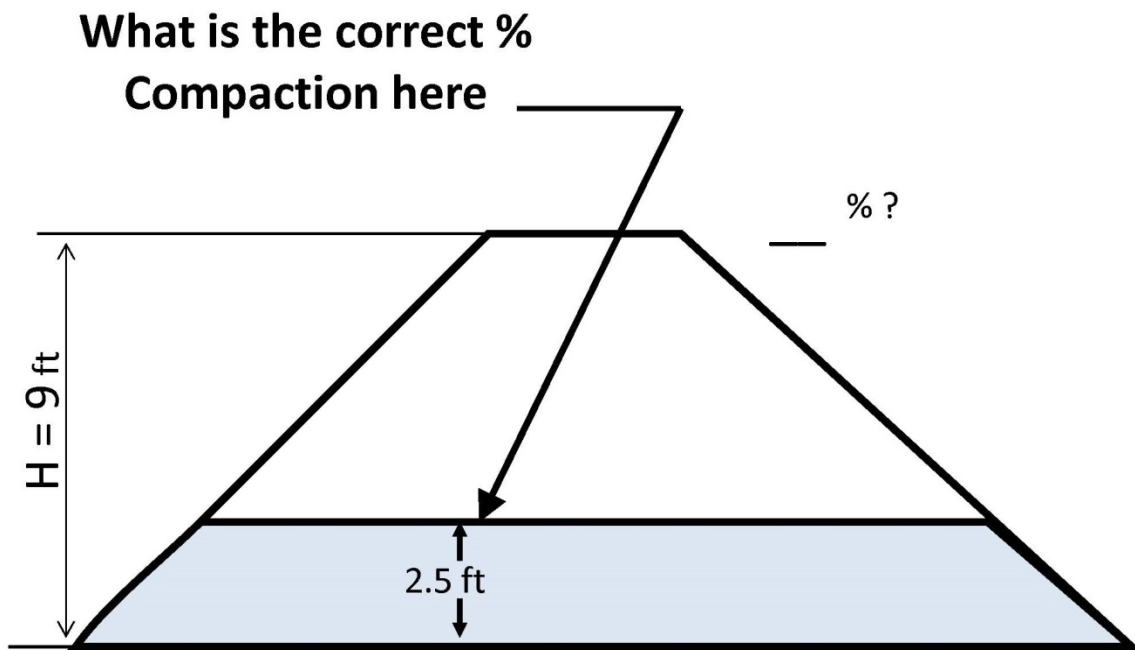

### 8.3.3 Compaction Acceptance and Testing Responsibilities

For compaction acceptance testing frequency, the Inspector should:

- Check PPG (copy in Appendix B)
- Project Special Provisions

Acceptance criteria (“Property/Quality” column in PPG) depends on:

- Nuclear/sand cone density and moisture (Article 205.06)
- DCP/SCP testing (Article 205.06) as directed by the Geotechnical Engineer or project Special Provisions

Testing responsibilities (“Mistic Test” column in PPG) are as follows:

- Inspector does production (PRO) testing
- Field Engineer does independent/investigative (IND/INV) testing

Field density of embankment materials is normally tested using a nuclear gauge according to Illinois Modified AASHTO T 310. Testing for IBV is normally performed using a DCP or SCP according to Illinois Test Procedure 501 or 502, respectively. The Inspector is responsible for process control (PRO) testing. The District Geotechnical staff will conduct independent assurance (IND) or investigative (INV) testing as necessary. The IND test is a comparison test that provides a separate check on the reliability of the PRO test. The INV test is a verification or check test of the in-place soil.

The Inspector must be trained in the proper use of nuclear density gauges in embankment inspection, and he or she must be field certified by the Nuclear Density Supervisor or Geotechnical Field Technician. The Inspector must also be familiar with documenting test results on MISTIC form BMPR MI701N (see Appendix B). Contact the Geotechnical Engineer for additional information regarding documentation since Districts may have supplementary worksheets.

With regard to compaction acceptance, beware of common contractor suggestions, all of which are not true:

- Disking does not dry or break down the soil!
- End loader teeth can work soil as well as disking!
- Clay soils are best compacted using vibration!
- 8-in. lifts are too thin, density can be achieved with 12-in. lifts!
- Compaction can be achieved from the trucks delivering soil!
- The trip to and from the borrow site heats the tires which dries the soil!

## 8.4 Performance Problems

Performance problems generally consist of the following:

- Unacceptable embankment settlement
- Excessive cut and fill slope movement

### 8.4.1 Unacceptable Settlement

When the subsurface data indicates the possibility of excessive settlement, the contract may include one or more methods of mitigating its effect on the completed pavement or structure. Embankment settlement causes roadway cracking, bumps at the roadway/bridge interface, and other problems caused by consolidation of foundations soils below the embankment and/or embankment soils placed during construction. Foundation soils settlement is typically addressed in plans. Proper construction can minimize embankment settlement. The Inspector shall check contract plans, Special Provisions, and the Geotechnical Report for the following:

- Settlement platform monitoring
- Amount of settlement expected
- Estimated construction waiting period
- Ground treatments specified
  - Wick drains, remove and replace, etc.

When carrying out settlement platform monitoring (Article 204.06), settlement plates shall be placed at the base prior to fill placement. Pipe extensions will be attached as necessary to project up through the fill as the fill is placed. Pipes are to be clearly marked as well as protected from construction damage. The settlement magnitude and time calculated based on laboratory tests conducted during design are generally conservative. As a result, settlement platform data often indicates that settlement is complete prior to the end of the construction waiting period. After installation, contact the Geotechnical Engineer for frequency of data collection. The data should be plotted as shown in Figure 26 and provided to the Geotechnical Engineer to review prior to ending the waiting period. The Geotechnical Engineer may also be contacted if there are any questions about settlement monitoring procedures. Figure 27 demonstrates how to determine the actual waiting period.

Methods for mitigating settlement problems may be shown in the plans. They may include removal and replacement of shallow compressible materials, surcharging, sand blankets, wick drains, light weight fill, land bridges, stone columns, or pile supported embankments.

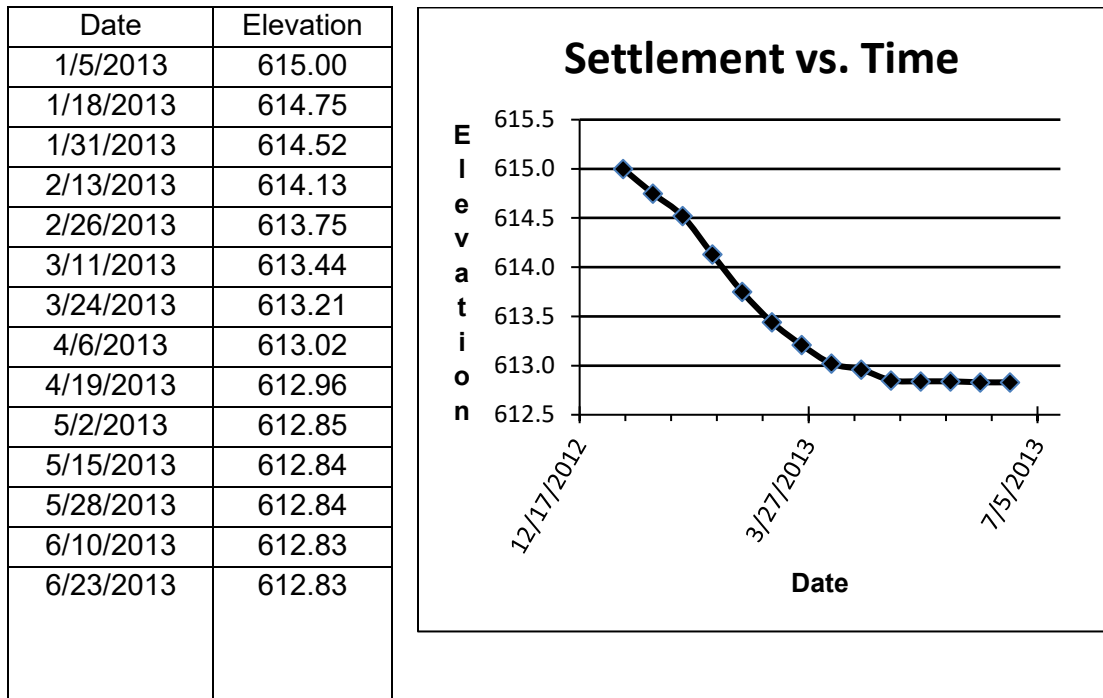

Figure 26. Table and graph of sample settlement plate data and convergence diagram.

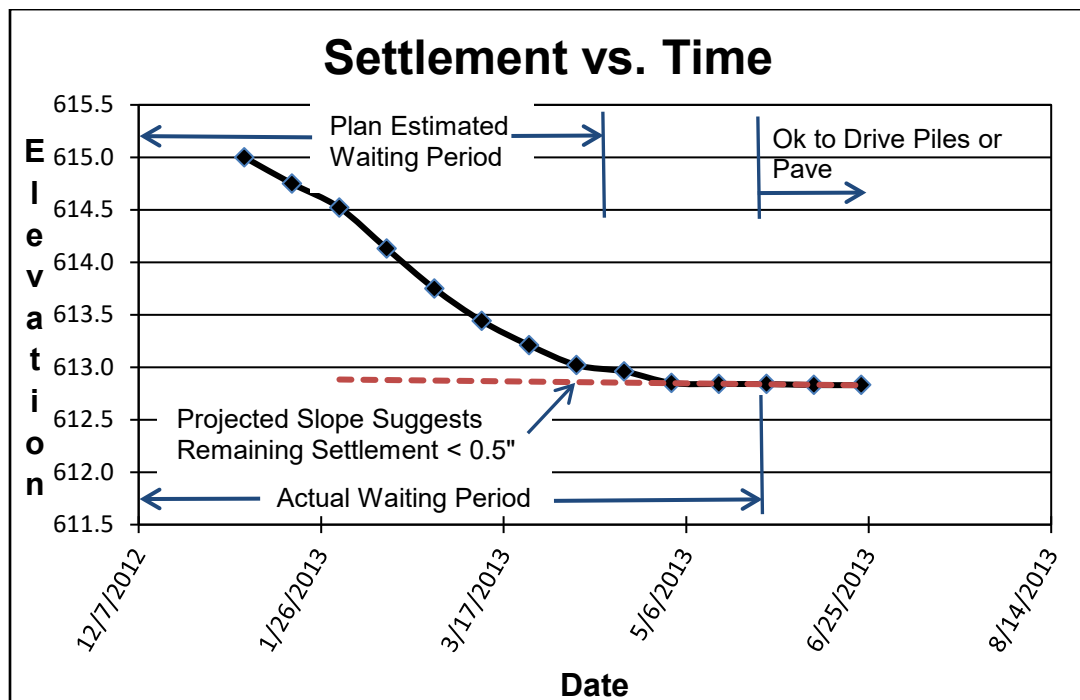

Figure 27. Plot of example determination of actual construction waiting period.

#### 8.4.2 Excessive Cut & Fill Slope Movement

Cut and fill slope movement generally signals slope instability during or after construction.

For cut slopes, the Inspector should look for the following:

- Separation crack(s) at “top of slope”
- Cracks or bulging at “mid-slope”
- Cracks or bulges at “toe of slope”
- Water seepage from face
- Erosion or sloughing off of the face

The variability of soil, groundwater elevation, and conditions beyond the top of slope can make predicting slope failures in cuts difficult. Sometimes, widening an existing cut a couple feet to add a shoulder can initiate a failure. The Inspector should routinely inspect all cuts to detect bulges on the slope, heaving at the toe of slope, cracks forming on the slope or behind the top of cut, and structure movement or distress at the top of cut. Any indication that a slope failure has occurred or is imminent, including surface sloughing due to erosion or seepage, must be reported to the Resident Engineer, Field Engineer, or Geotechnical Personnel.

In fill sections:

- Slope failures are caused by poor embankment construction
  - May happen immediately, or long, after construction
- Look out for signs of movement, bulges, distress, cracks, water, etc.
  - Similar to warning signs seen in cut sections

Regular inspection of the fill embankment slopes should be carried out such that any signs of distress or movement are detected. Should any signs be ignored, then failures may occur.

### 9. SHALLOW FOUNDATION INSPECTION FOR STRUCTURES

Structures, when not supported on piles or drilled shafts, are supported on spread footings, which spread the large, concentrated loads on the foundation soils. Shallow foundation soils support:

**Abutment Spread Footing**  
Foundation Soil has to Support the Footing

**Bridge Pier Spread Footings**  
Foundation Soil has to Support the Footing

**Sign Structure Spread Footings**  
Foundation Soil has to Support the Footing

**Supports Retaining Wall Spread Footings**  
Foundation Soil has to Support the Footing

**Culvert Wing Wall Spread Footings**  
A Wing Wall is a Retaining wall as above

**3-sided**  
Foundation Soil has to Support the Footing

Figure 28. Photos of examples of shallow foundation uses in highway features.

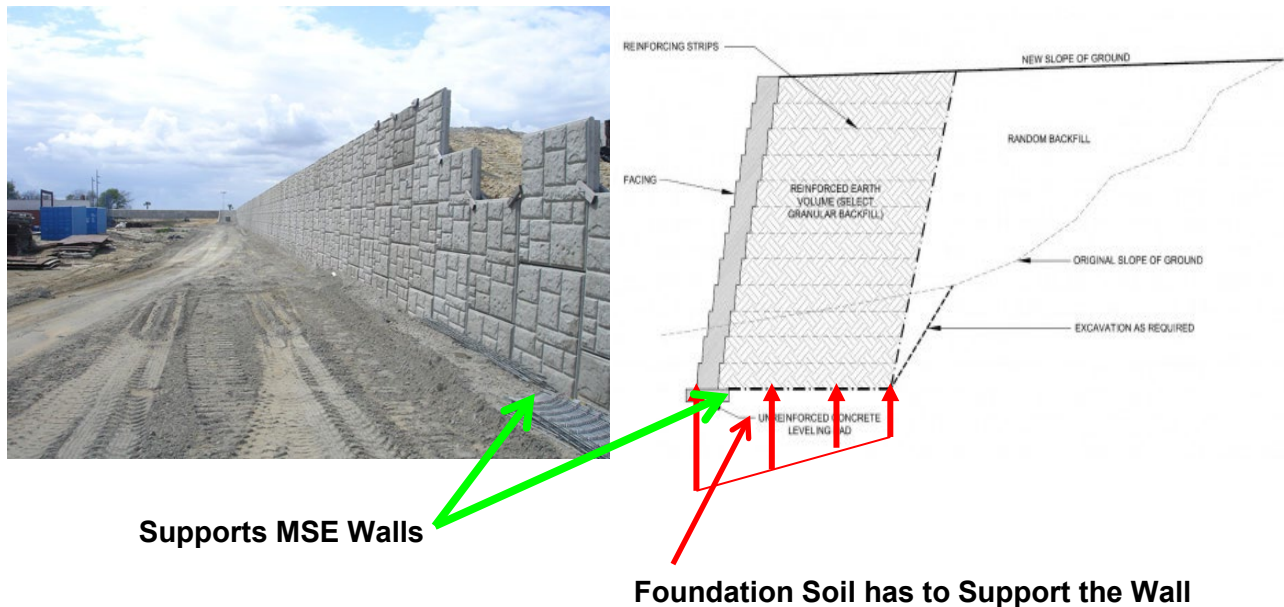

(a) (b)  
**Figure 29. Photo of typical Mechanically Stabilized Earth (MSE) wall (a) with extent of the shallow foundation illustrated (b).**

### 9.1 Soil Bearing Verification for Shallow Foundations

The contract plans should include the **maximum applied service bearing pressure** (also shown as  $Q_{max}$ ). For Mechanically Stabilized Earth (MSE) walls, this is referred to as the “equivalent uniform applied service (unfactored) nominal bearing pressure” in Article 522.09(a) of the Standard Specifications. Note that a service bearing pressure is typically less than a factored bearing pressure. However, it is still referred to as the  $Q_{max}$  for inspection purposes. If the plans do not show a  $Q_{max}$ , the Inspector must contact the design engineer to determine the necessary soil strength to be verified. Inspectors with limited or no past experience with the different foundation soils should notify the District Geotechnical Engineer approximately two days before a spread footing is excavated to its plan “footing” elevation. Based on visual inspection, the Inspector should determine whether or not the foundation materials encountered in the excavation are consistent with those indicated in the boring data, and whether or not they are granular. If the foundation soils are not consistent with the boring data, the Inspector must contact the Geotechnical Engineer. If the foundation soils are not granular, they must be tested to determine a typical (average) unconfined compressive strength ( $Q_u$ ) using a DCP or SCP. As a rough check, the average  $Q_u$  value must be greater than or equal to the  $Q_{max}$  value shown on the plans. If the average  $Q_u$  of the foundation soils at the footing elevation is less than  $Q_{max}$ , the soils may be further excavated to an additional 1 or 2 feet as shown in Figure 30. The excavated, weak foundation soils must be replaced with one of the following:

- Class D, or better, crushed stone/gravel (CA 1, CA 3, CA 5, CA 7, CA 11, CA 13, CA 14, CA 15, CA 16, or CA 18)
- Cast-in-place concrete
- Aggregate Subgrade Improvement according to Table 4
- Or as specified in a Special Provision



The actual applied bearing pressure at the base of the removal ( $q^*$ ) is determined by the equations provided in Figure 30. The  $q^*$  at various depths will be less than  $Q_{max}$ . In this case, the  $Q_u$  below the base of the excavation will have to be compared with the  $q^*$  value, not the  $Q_{max}$ . If the average  $Q_u$  of the foundation soils within 2 feet below the design footing elevation is not greater than or equal to the  $q^*$ , the Inspector must contact the Resident Engineer, Field Engineer, or the Design Engineer for further direction.

If the foundation soils are granular, a DCP can be used to determine an equivalent  $Q_u$  value and make a field verification of the bearing capacity. Spread footings on shale must be constructed as soon as possible after excavation to minimize deterioration due to weathering or swell. If footing construction cannot be poured the same day or even within a couple of hours after completing the excavation (depending on the shale's sensitivity), a concrete seal coat "mud slab" may be placed to protect the shale.

The  $q^*$  is determined by multiplying  $Q_{max}$  by a Reduction Factor (RF) as follows:

$$q^* = RF \times Q_{max} \quad \text{Eq. 9-1}$$

Where RF is calculated for a 60 degree pressure distribution (commonly used by the Department) as follows:

$$RF = \frac{B}{B+1.155D} \quad \text{Eq. 9-2}$$

Note that  $q^*$  acts over width **D** to **E**, while the over-excavation limits extend from **C** to **F** in Figure 30.

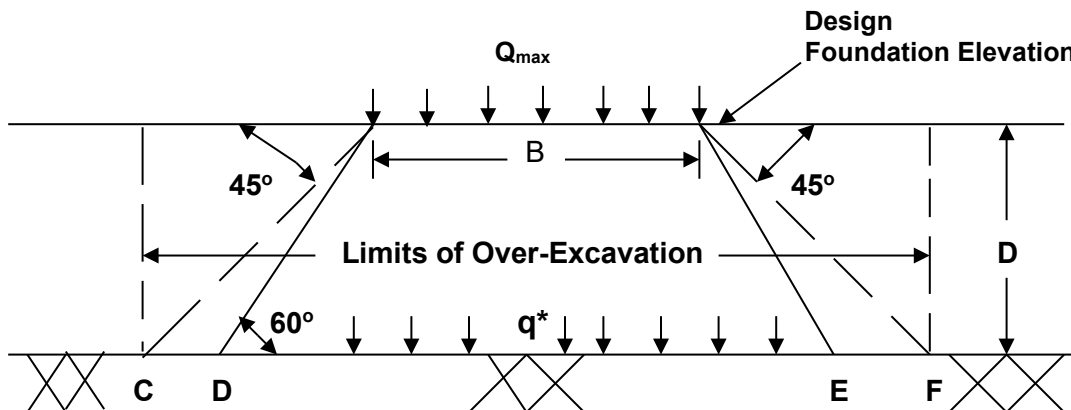

**Figure 30. Illustration for determination of Reduced Applied Bearing Pressure ( $q^*$ ).**

**Table 9. Reduction Factors (RF) for various footing widths (B) at 60 degree load distribution for over excavation depths (D).**

Depth (D) Below Bottom of Footing	Footing Width (B)					
	2 ft	4 ft	6 ft	8 ft	10 ft	12 ft
0 ft	1.0	1.0	1.0	1.0	1.0	1.0
1 ft	0.63	0.77	0.83	0.87	0.89	0.91
2 ft	0.46	0.63	0.72	0.77	0.81	0.83

**CLASS PROBLEM 8: Determine the required foundation treatment thickness.** The first of the two examples has been done for you.

EXAMPLE 1:  $Q_{\max} = 5 \text{ ksf}$  (= 2.5 tsf),  $B = 4 \text{ ft}$ .

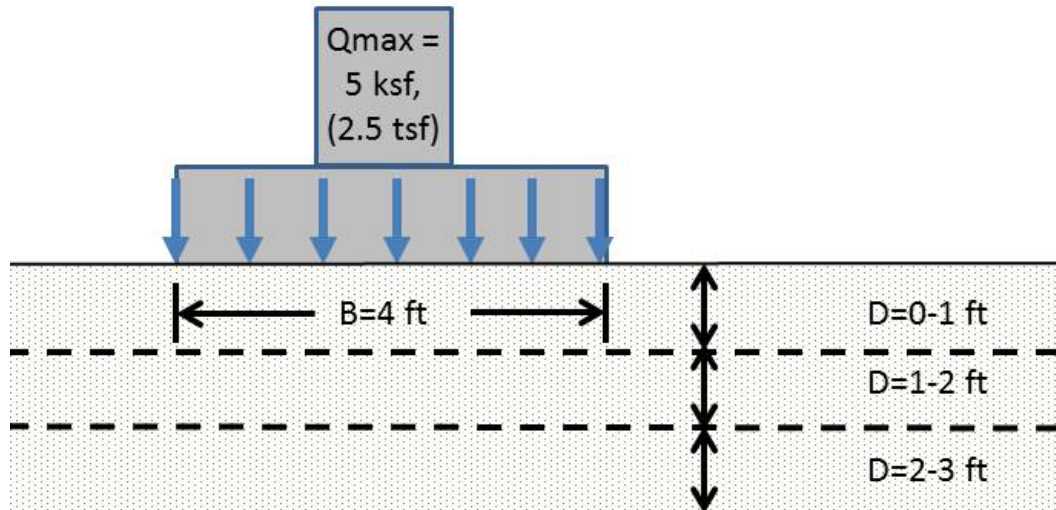

**Solution Process:** Follow these steps:

Step 1. Determine the soil's average IBV at 0 ft., 1 ft., and 2 ft. depths:  
(Given for the purpose of working this problem.)

$$\begin{aligned} \text{IBV} &= 6 && \text{at } D = 0-1 \text{ ft.} \\ \text{IBV} &= 4 && \text{at } D = 1-2 \text{ ft.} \\ \text{IBV} &= 8 && \text{at } D = 2-3 \text{ ft.} \end{aligned}$$

Step 2. Obtain the soil's equivalent  $Q_u$  at 0 ft., 1 ft., and 2 ft. depths and convert units to ksf:  
(Use Figure 20 on page 36.)

$$Q_u = 1.9 \text{ tsf} \times \frac{2 \text{ kips}}{1 \text{ ton}} = 3.8 \text{ ksf at } D = 0-1 \text{ ft.}$$

$$Q_u = 1.3 \text{ tsf} \times \frac{2 \text{ kips}}{1 \text{ ton}} = 2.6 \text{ ksf at } D = 1-2 \text{ ft.}$$

$$Q_u = 2.6 \text{ tsf} \times \frac{2 \text{ kips}}{1 \text{ ton}} = 5.2 \text{ ksf at } D = 2-3 \text{ ft.}$$

Step 3. Obtain the foundation  $Q_{\max}$  pressure Reduction Factor (RF) values at 0 ft., 1 ft., and 2 ft. depths, for  $B = 4 \text{ ft}$ .: (Use Table 9)

$$\begin{aligned} \text{RF} &= 1.0 && \text{at } D = 0 \text{ ft.} \\ \text{RF} &= 0.77 && \text{at } D = 1 \text{ ft.} \\ \text{RF} &= 0.63 && \text{at } D = 2 \text{ ft.} \end{aligned}$$

Step 4. Obtain the foundation's Reduced Applied Bearing Pressure ( $q^*$ ) at 0 ft., 1 ft., and 2 ft. depths:

(Use Equation 9-1:  $q^* = RF \times Q_{max}$  from page 60.)

$$q^* = 1.0 \times 5 = 5.0 \text{ ksf} \quad \text{at } D = 0 \text{ ft.}$$

$$q^* = 0.77 \times 5 = 3.8 \text{ ksf} \quad \text{at } D = 1 \text{ ft.}$$

$$q^* = 0.63 \times 5 = 3.2 \text{ ksf} \quad \text{at } D = 2 \text{ ft.}$$

Step 5. Compare  $Q_u$  with  $q^*$  at 0 ft., 1 ft. & 2 ft. depths:

Is  $Q_u \geq q^*$ ?

$$Q_u: 3.8 \text{ ksf} < q^*: 5.0 \text{ ksf} \quad \text{at } D = 0 \text{ ft.} \quad \text{Needs excavation}$$

$$Q_u: 2.6 \text{ ksf} < q^*: 3.8 \text{ ksf} \quad \text{at } D = 1 \text{ ft.} \quad \text{Needs excavation}$$

$$Q_u: 5.2 \text{ ksf} > q^*: 3.2 \text{ ksf} \quad \text{at } D = 2 \text{ ft.} \quad \text{OK to undercut and replace 2 ft.}$$

D (ft)	Soil			Foundation			Undercut Required?
	IBV	$Q_u$ (tsf)	$Q_u$ (ksf)	$Q_{max}$ (ksf)	RF	$q^*$ (ksf)	
0'-1'	6	1.9	3.8	5.0	1.0	5.0	Needs Excavation
1'-2'	4	1.3	2.6	5.0	0.77	3.8	Needs Excavation
2'-3'	8	2.6	5.2	5.0	0.63	3.2	OK to undercut and replace 2 ft.
	Step 1	Step 2			Step 3	Step 4	Step 5

**EXAMPLE 2:**

**Given:**  $Q_{max} = 2 \text{ ksf} (= 1 \text{ tsf})$ ,  $B = 12 \text{ ft}$ .

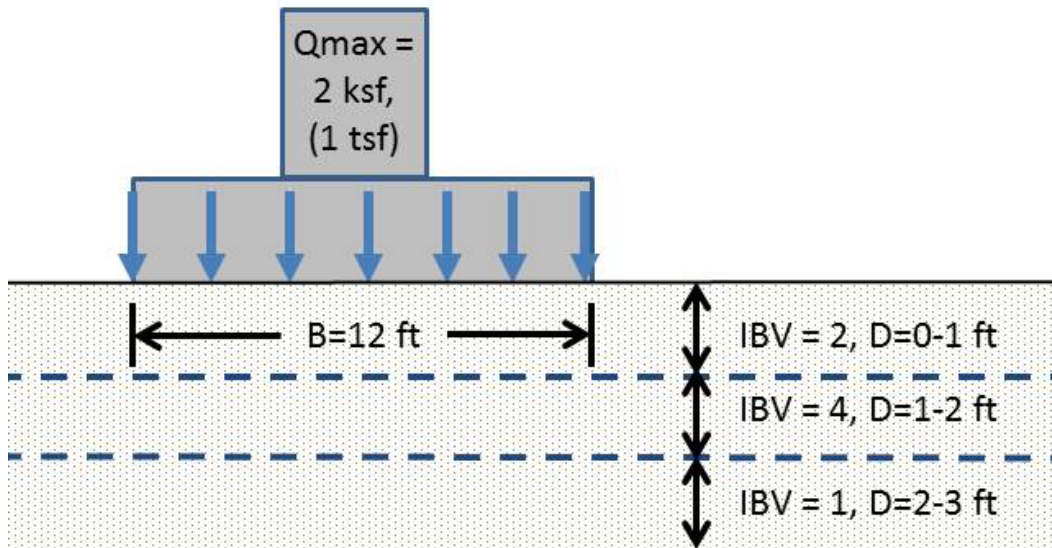

**Solution:** Repeat steps 1 through 5 to determine if undercutting and replacement is feasible.

D (ft)	Soil		Foundation			Undercut Required?	
	IBV	$Q_u$ (tsf)	$Q_u$ (ksf)	$Q_{max}$ (ksf)	RF		$q^*$ (ksf)
0'-1'	2						
1'-2'	4						
2'-3'	1						
	Step 1	Step 2			Step 3	Step 4	Step 5

## 9.2 Foundation Preparation for Box Culverts

The foundation soil requirements for a culvert barrel vary depending on the size of the culvert, the fill height above the culvert, the current foundation soil loading, and whether the culvert is pre-cast or cast-in-place. Foundation soils supporting culvert wing walls on spread footings have specific strength requirements based on the applied loadings.

During the design of box culverts, subsurface boring data is obtained and included in the plans. The designer will indicate on the plans any removal and replacement required to address settlement. The plan area and depth of removal should correspond to the boring data so that the Inspector can determine the material the designer wants removed and what can remain. Since the conditions encountered upon excavation can differ, the Geotechnical Engineer and Field Construction Engineer may need to extend or reduce the limits to address the “as encountered conditions”. Unless otherwise noted, the limits and depth of removal and replacement should not be significantly altered by the Inspector without consulting with the Geotechnical Engineer. If there are differing or difficult subsurface conditions regarding undercutting at culverts, contact the Geotechnical Engineer.

When no removal is indicated in the plans, the Contractor may need a so-called “working platform” to properly construct the culvert bottom slab when the foundation soils become unable to support equipment and laborers during excavation, rebar placement, forming and concrete placement. The need for such platforms is dependent on the type, thickness and strength of the soils encountered, the method of water diversion selected by the Contractor, precipitation, construction sequence and the time of the year the box is constructed, and thus, such platforms generally are not shown on the plans. The Inspector should contact the Geotechnical Engineer to determine if field conditions necessitate a working platform. General guidelines for working platforms based on DCP data are shown in Table 10. Soil should be tested to a depth 3 feet below the bottom of the culvert.

**Table 10. Guideline for working platforms at culverts.**

DCP Rate (in./blow)	IBV	$Q_u$ (tsf)	Depth Guideline
> 4.6	< 1	< 0.3	Contact Geotechnical Engineer
4.6 to 3.3	1 to 1.5	0.3 to 0.5	2 ft.
3.3 to 2.6	1.5 to 2	0.5 to 0.7	1 ft.
2.6 to 2.0	2 to 3	0.7 to 1.0	0.0 to 0.5 ft.
< 2.0	> 3	> 1.0	0.0 ft.*
* Note: Bedding is required beneath pre-cast culverts even if the recommended undercut is zero according to Article 540.06 of the Standard Specifications.			

The recommended working platform depth represents the total depth of replacement material beneath the box. This includes the bedding material required beneath pre-cast box culverts according to Article 540.06 of the Standard Specifications. (Note that bedding is required beneath pre-cast culverts even if the recommended undercut is zero.)

Unsuitable materials are generally replaced with aggregate when soil strength and groundwater conditions dictate. A special provision for Aggregate Subgrade Improvement of Rockfill should be included in the plans to indicate the replacement material properties and capping requirements. If there is no special provision in the contract documents, the selected gradation of aggregate should be as directed by the Geotechnical Engineer.

## 10. REFERENCES

- AASHTO. (2022). *Standard Specifications for Transportation Materials and Methods of Sampling and Testing* (Forty-second ed.). Washington, D. C.: American Association of State Highway and Transportation Officials.
- IDOT. (1987, November 1). *District 2 Embankment Inspector's Manual*.
- IDOT. (2015, Revised December 4, 2020). *Geotechnical Manual*. Retrieved from <https://public.powerdms.com/IDOT/documents/2001840/Geotechnical%20Manual>
- IDOT. (2002, April). *District 6 Geotechnical Field Guide*.
- IDOT. (2005, May 1). *Subgrade Stability Manual*. Retrieved from <https://public.powerdms.com/IDOT/documents/2144325/Subgrade%20Stability%20Manual>
- IDOT. (2021). *Construction Manual*. Retrieved from <https://idot.illinois.gov/content/dam/soi/en/web/idot/documents/doing-business/manuals-guides-and-handbooks/highways/construction/construction-manual/construction-manual.pdf>
- IDOT. (2020, May 15). *Project Procedures Guide*. Retrieved from <https://public.powerdms.com/IDOT/documents/2144679/Project%20Procedures%20Guide>
- IDOT. (2022, January 1). *Standard Specifications for Road and Bridge Construction*. Retrieved from <https://public.powerdms.com/IDOT/documents/1945348/Standard%20Specifications%20for%20Road%20and%20Bridge%20Construction%202022>
- IDOT. (2022, December 1). *Manual of Test Procedures for Materials*. Retrieved from <https://public.powerdms.com/IDOT/documents/2732503>

This page left intentionally blank.

**SPECIFIC TASK TRAINING**  
**PROGRAM**

**S-33**

**SOILS FIELD TESTING**  
**AND INSPECTION**

**APPENDICES**



This page left intentionally blank.

**APPENDIX A: TEST PROCEDURES COVERED IN THIS COURSE**

Please refer to the appropriate page number(s) in the Department's *Manual of Test Procedures for Materials* for detailed information concerning any of the following Test Procedures.

<b>General Description of Test</b> In order of appearance in Course Reference Manual	<b>Official Description (Name) of Test Procedure</b>	<b>Standard</b>	<b>Page Number(s) in December 1, 2023 <i>Manual of Test Procedures for Materials</i></b>
<b>Standard Proctor Test</b>	"Moisture-Density Relations of Soils Using a 2.5-kg (5.5-lb) Rammer and a 305-mm (12-in.) Drop"	Illinois Modified AASHTO T 99, Method C	117 – 121
<b>Moisture Content Test (Laboratory)</b>	"Laboratory Determination of Moisture Content of Soils"	Illinois Modified AASHTO T 265	171
<b>Moisture Content Test (Field)</b>	Refer to 1.) One Point Method for Determining Maximum Dry Density and Optimum Moisture; also see 2.) ASTM D 4643-08, "Standard Test Method for Determination of Water (Moisture) Content of Soil by Microwave Oven Heating" and 3.) ASTM D 4959-16, "Standard Test Method for Determination of Water Content of Soil by Direct Heating"	Illinois Modified AASHTO T 272; ASTM D 4643 ASTM D 4959	177-179  Also see ASTM D 4643 and ASTM D 4959 (not in Manual)
<b>Field One-Point Proctor Test</b>	"One-Point Method for Determining Maximum Dry Density and Optimum Moisture"	Illinois Modified AASHTO T 272	177 – 179
<b>Family of Curves</b>	"Developing Soil Moisture-Density Relations (Family of Curves)"	Illinois Modified AASHTO R 75	311 – 312
<b>Field Density and Moisture Testing using the Nuclear Gauge</b>	"In-Place Density and Moisture Content of Soil and Soil-Aggregate by Nuclear Methods" (Shallow Depth)	Illinois Modified AASHTO T 310	247 – 252
<b>Field Density and Moisture Testing using the Sand Cone</b>	"Density of Soil In- Place by the Sand Cone Method"	Illinois Modified AASHTO T 191	153
<b>Dynamic Cone Penetrometer (DCP) Testing</b>	"Dynamic Cone Penetration (DCP)"	Illinois Test Procedure 501	35 – 40
<b>Static Cone Penetrometer (SCP) Testing</b>	"Static Cone Penetration (SCP)"	Illinois Test Procedure 502	41 – 44
<b>Pocket Penetrometer Testing</b>	<i>Not an official IDOT test procedure</i>	---	---

This page left intentionally blank.

**APPENDIX B: PPG MISTIC TESTS AND TESTING FREQUENCY**

May 15, 2020

ATTACHMENT 4

Project Procedures Guide

**GUIDELINES FOR USE OF MISTIC “TYPE TEST” FOR MAJOR MATERIAL CATEGORIES**

The following chart lists the report form and “Type Test” for major material categories. This chart will assist field personnel in properly identifying the sample on the MISTIC Sample Identification and/or field test reports. The chart is not intended to identify points of acceptance or tests appropriate for the listed materials. Refer to the applicable specification to determine test requirements. A “Type Test” column has been provided for both IDOT’s traditional non-QMP testing program and the Quality Management Programs (QMP).

MATERIAL CATEGORY	TEST	LOCATION	FORM <sup>1</sup>	MISTIC TYPE TEST	
				NON-QMP DEPARTMENT	QMP PROGRAM DEPARTMENT
Aggregates	Quality Gradation	Source	BMPR LM6 Template MI-504 <sup>2</sup>	PRO, PRE	IND, INV
	Random A Quality at PCC	Mix Plant	BMPR LM6 Template MI-504 <sup>2</sup>	INV	IND, INV
	Gradation	Jobsite	MI-504 <sup>2</sup>	INV	IND, INV
	Gradation, etc.	Mix Design	BMPR LM6 Template	PRE	PRE
	Gradation – Hot Bins/Combined Belt or Cold Feeds	Mix Plant/Lab	N/A <sup>2</sup>	N/A	IND, INV
Hot Mix Asphalt (HMA) Mixtures	Gradation – Solvent Extraction/Ignition Oven	Mix Plant/Lab	N/A <sup>2</sup>	N/A	IND, INV
	Air Voids	Mix Plant/Lab	N/A <sup>2</sup>	N/A	IND, INV
	Asphalt Content – Solvent Extraction, Nuclear, Ignition Oven	Mix Plant/Lab	N/A <sup>2</sup>	N/A	IND, INV
	Field VMA	Mix Plant/Lab	N/A <sup>2</sup>	N/A	IND, INV
	Density – Nuclear/Core	Jobsite/Laboratory	BMPR MI303N	N/A	IND, INV
PCC Mixture	PG Asphalt Binder – QA Sample	Mix Plant/BC Lab	BMPR LM6 Template	PRO	INV
	Air, Slump, and Quantity	Jobsite	BMPR MI654	ACC	IND, INV
	Strengths - Beams or Cylinders	Jobsite/Laboratory	BMPR MI655	PRO	IND, INV
Soils	Density	Jobsite	BMPR MI701N	PRO	
	Immediate Bearing Value (using DCP or SCP)	Jobsite	BMPR SL30 or BMPR SL31	N/A	
Topsoil	Laboratory	Laboratory	BMPR LM6 Template	ACC	
	Random Check/Verification	Laboratory	BMPR LM6 Template	INV	
Misc. Products	Random Check/Verification	Laboratory	BMPR LM6 Template	INV	

- 1 See the IDOT website, [Bureau of Materials forms](#), for standard forms or contact your IDOT district materials office.
- 2 An approved spreadsheet program/form may also be used.
- 3 The reporting format is specified by the data input requirements for MISTIC input. A spreadsheet program is generally used.

## PPG MISTIC TESTS AND TESTING FREQUENCY

Project Procedures Guide

May 15, 2020

### SAMPLING SCHEDULES

The following Sampling Schedules list the minimum sampling and testing frequencies for non-QMP project-produced materials. (Refer to the current applicable standard, specifications, special provisions and stand-alone documents therein for sampling and testing frequency requirements for QC/QA, PFP, and QCP project-produced materials.) Good judgment on the part of the **Inspector** is essential for proper control of the work. Onsite job conditions such as consistency, methods, equipment, and weather may result in a decision to increase the frequencies listed in these Sampling Schedules.

Likewise, reliance should never be placed entirely on the numerical results of sampling and testing when determining the acceptability of the materials and construction work. Observation of the actual construction operations and processes is necessary to ensure that the materials incorporated and the construction procedures utilized are acceptable and in accordance with the contract, plans, and specifications.

The Sampling Schedules do not list frequencies for independent assurance testing. Independent assurance testing, or IND testing, is a way of ensuring that the **Inspector** remains capable of performing the tests properly. IND testing requirements are addressed in Section 900, **TRAINED TECHNICIANS**.

**PPG MISTIC TESTS AND TESTING FREQUENCY**

May 15, 2020

**SAMPLING SCHEDULE 1: EMBANKMENTS, SUBGRADES, AND GRANULAR COURSES**

MATERIAL	SPECIFICATION REFERENCE	PROPERTY/QUALITY	FREQUENCY	MISTIC TEST	FORM
Earth, Stone, or Gravel Embankments	Article 205.06*	Standard Moisture Density Control Curve	Compaction curve data is required for each major change in embankment material. This data may be furnished in advance by <b>District Laboratory</b> .		No standard form
	Article 205.06*	Density	1 test per 20,000 cu yd. for a continuous operation, by <b>Project Inspector</b> . In confined areas, 1 test per 3 ft. of lift and not less than 1 test per fill area, by <b>Project Inspector</b> .	PRO	BMPR MI701N
Subgrades	Article 301.04*	Density	1 test per 1500 ft. of entire length of subgrade through both cut and fill areas, by <b>Project Inspector</b>	PRO	BMPR MI701N
	Article 301.04*	Immediate Bearing Value Using Dynamic or Static Cone Penetrometer	As determined by the District Geotechnical Engineer	PRO	BMPR SL30 or SL31
Modified Soil with Lime, Portland Cement, Portland Blast-Furnace Slag Cement, or Fly Ash	Article 302.09*	Density	1 test per 1500 ft. of treated area, by <b>Project Inspector</b>	PRO	BMPR MI701N
	Article 302.11*	Immediate Bearing Value Using Dynamic or Static Cone Penetrometer	As determined by the District Geotechnical Engineer	PRO	BMPR SL30 or SL31

**PPG MISTIC TESTS AND TESTING FREQUENCY**

May 15, 2020

Project Procedures Guide

**SAMPLING SCHEDULE 1: EMBANKMENTS, SUBGRADES, AND GRANULAR COURSES, Continued**

MATERIAL	SPECIFICATION REFERENCE	PROPERTY/QUALITY	FREQUENCY	MISTIC TEST	FORM
Subgrades, continued Lime	Section 1012	Various	Minimum of 1 sample on 1 <sup>st</sup> day, and then 1 sample per 750 tons [or 400,000 gal lime slurry] thereafter, by <b>District Inspector</b>	INV	BMPR LM6 Template
Portland Cement and Portland Blast-Furnace Slag Cement	Section 1001	Various	When requested by <b>CBM</b>	INV	BMPR LM6 Template
Fly Ash	Section 1010	Various	When requested by <b>CBM</b>	INV	BMPR LM6 Template
Granular Courses Base Course and Granular Embankment, Type A	Article 351.05*	Density	1 test per 1000 ft. of pavement, by <b>Project Inspector</b>	PRO	BMPR MI701N
Subbase Granular Material, Type A	Article 311.05*				
Aggregate Surface Course, Type A	Article 402.05*				
Select Fill Used for Retaining Wall Applications Utilizing Soil Reinforcement	Article 1003.07* Article 1004.06*	Various	1 sample before construction begins, and then 1 sample for every 40,000 tons by <b>District Inspector</b>	INV	BMPR LM6 Template
	Article 522.09* Article 522.10* Article 522.11* Article 522.12*	Density	1 test per 20,000 cu yd. for a continuous operation, by <b>Project Inspector</b> . In confined areas, 1 test per 3 ft. of lift and not less than 1 test per fill area, by <b>Project Inspector</b> .	PRO	BMPR MI701N

\* Test information contained in the [Manual of Test Procedures for Materials](#).

## PPG MISTIC TESTS AND TESTING FREQUENCY

Project Procedures Guide		May 15, 2020			
SAMPLING SCHEDULE 2: NON-BITUMINOUS STABILIZED SUBBASE AND STABILIZED BASE COURSE					
MATERIAL	SPECIFICATION REFERENCE	PROPERTY/QUALITY	FREQUENCY	MISTIC TEST	FORM
General Fine Aggregate Coarse Aggregate	Section 1003*	Gradation	1 test per week of production, by <b>Plant/District Inspector</b>	INV	MI 504
	Section 1004*				
Portland Cement	Section 1001	Various	When requested by <b>CBM</b>	INV	BMPR LM6 Template
Lime	Section 1012	Various	Minimum of 1 sample on 1 <sup>st</sup> day, and then 1 sample per 500 tons, by <b>District Inspector</b>	INV	BMPR LM6 Template
Fly Ash (for CAM II)	Article 1010.02	Various	When requested by <b>CBM</b>	INV	BMPR LM6 Template
Stabilized Base and Subbase Courses Cement Aggregate Mixture II	Article 312.09*	Air	1 test per 1000 ft., by <b>Project Inspector</b>	ACC	BMPR MI654
	Article 312.09*				



**PPG MISTIC TESTS AND TESTING FREQUENCY**

May 15, 2020

Project Procedures Guide

**SAMPLING SCHEDULE 2: NON-BITUMINOUS STABILIZED SUBBASE AND STABILIZED BASE COURSE, Continued**

MATERIAL	SPECIFICATION REFERENCE	PROPERTY/QUALITY	FREQUENCY	MISTIC TEST	FORM
Stabilized Base and Subbase Courses, Continued Lime Stabilized Soil Base Course	Article 350.01* or Special Provision*	Density	1 test per 1500 ft. of pavement, by <b>Project Inspector</b>	PRO	BMPR MI701N
	Article 310.11*	Immediate Bearing Value Using Dynamic Cone Penetrometer	As determined by the District Geotechnical Engineer	PRO	BMPR SL30
Lime Stabilized Soil Subbase Course	Article 310.09* or Special Provision*	Density	1 test per 1500 ft. of pavement, by <b>Project Inspector</b>	PRO	BMPR MI701N
	Article 310.11*	Immediate Bearing Value Using Dynamic Cone Penetrometer	As determined by the District Geotechnical Engineer	PRO	BMPR SL30
Soil-Cement	Article 352.11*	Density	1 test per 1000 ft. of pavement, by <b>Project Inspector</b>	PRO	BMPR MI701N

\* Test information contained in the [Manual of Test Procedures for Materials](#).

**QC/QA, PFP, and QCP:**

Please note that the sampling and testing frequency table above does not apply to **QC/QA**, **PFP** or **QCP** projects. Please refer to the current applicable, standard specification, special provision and stand-alone documents therein for sampling and testing frequency requirements.

**APPENDIX C: FORMS & IDH CHART**

Copies of the following forms are available at <https://idot.illinois.gov/doing-business/material-approvals/idot-material-labs/soils/forms.html>



**Illinois Department  
of Transportation**

**Moisture-Density Worksheet**

Test ID No.: \_\_\_\_\_

Date: \_\_\_\_\_

Station: \_\_\_\_\_

Offset: \_\_\_\_\_

Depth: \_\_\_\_\_

Sampled From Location: \_\_\_\_\_

Soil Description: \_\_\_\_\_

Remarks: \_\_\_\_\_

County: \_\_\_\_\_

Section: \_\_\_\_\_

Route: \_\_\_\_\_

District: \_\_\_\_\_

Contract No.: \_\_\_\_\_

Job No.: \_\_\_\_\_

Project No.: \_\_\_\_\_

**Test Procedure (check one):**

Illinois Modified AASHTO T 99    
  Illinois Modified AASHTO T 180    
 Method (check one):  A  B  C  D  
 Illinois Modified AASHTO T 134    
 Method (check one):  A  B

For Illinois Modified Tests, refer to Manual of Test Procedures for Materials.

Starting Sample Dry Weight: \_\_\_\_\_ Mold Weight: \_\_\_\_\_ Mold Factor: \_\_\_\_\_

Target Moisture Content (%)	Added Water Weight (g)	Wet Soil in Mold Weight (g)	Pan No.	Pan Weight (g)	Wet Soil + Pan Weight (g)	Dry Soil + Pan Weight (g)	Water in Soil Weight (g)	Dry Soil Weight (g)	Actual Moisture Content (%)	Wet Density (pcf)	Dry Density (pcf)

**RESULTS:**

Standard Dry Density (pcf): \_\_\_\_\_ Optimum Moisture Content (%): \_\_\_\_\_

**Coarse Particle Correction (if applicable):**

Standard Dry Density (pcf): \_\_\_\_\_ Optimum Moisture Content (%): \_\_\_\_\_

Test completed by: \_\_\_\_\_

Printed 1/24/2023

BMPR SL02 (Rev. 08/01/18)



**Dynamic Cone Penetration Test**

Date: \_\_\_\_\_ County: \_\_\_\_\_  
 Weather: \_\_\_\_\_ Section: \_\_\_\_\_  
 Inspector: \_\_\_\_\_ Route: \_\_\_\_\_  
 Company (Consultants): \_\_\_\_\_ District: \_\_\_\_\_  
 Design No.: \_\_\_\_\_ Contract No.: \_\_\_\_\_  
 Sheet No.: \_\_\_\_\_ Job No.: \_\_\_\_\_  
 Contractor: \_\_\_\_\_ Project: \_\_\_\_\_

Test Location and Remarks <sup>a</sup> <sub>b</sub>	Initial Depth	<input type="checkbox"/> Subgrade <input type="checkbox"/> Foundation					
		Depth <sup>c</sup>	Blows	Rate <sup>d</sup>	IBV	Q <sub>u</sub>	
		Depth					
		Blows					
		Rate					
		IBV					
		Q <sub>u</sub>					
		Depth					
		Blows					
		Rate					
		IBV					
		Q <sub>u</sub>					
		Depth					
		Blows					
		Rate					
		IBV					
		Q <sub>u</sub>					
		Depth					
		Blows					
		Rate					
		IBV					
		Q <sub>u</sub>					

<sup>a</sup> Indicate station and offset.  
<sup>b</sup> Include soil type, moisture, rutting, or cut/fill information as applicable.  
<sup>c</sup> Depth is cumulative in inches.  
<sup>d</sup> Rate is inches of penetration per blow.

Comments:

Rate	IBV	Q <sub>u</sub> *	Rate	IBV	Q <sub>u</sub> *
0.5	17	5.4	1.3	5	1.6
0.6	13	4.2	1.5	4	1.3
0.7	11	3.5	2.0	3	1.0
0.8	9	2.9	2.6	2	0.6
0.9	8	2.6	3.0	1.7	0.5
1.0	7	2.2	3.3	1.5	0.5
1.1	6	1.9	4.6	1	0.3
1.2	5.5	1.8	>4.6	<1	<0.3

\*Q<sub>u</sub> value calculated from IBV whole number.  
 $IBV = 10^{0.84 - 1.26 \times \text{LOG}(\text{Rate})}$        $Q_u \text{ (tsf)} = 0.32 \times IBV$



**Static Cone Penetration Test**

Date: \_\_\_\_\_ County: \_\_\_\_\_  
 Weather: \_\_\_\_\_ Section: \_\_\_\_\_  
 Inspector: \_\_\_\_\_ Route: \_\_\_\_\_  
 Company (Consultants): \_\_\_\_\_ District: \_\_\_\_\_  
 Design No.: \_\_\_\_\_ Contract No.: \_\_\_\_\_  
 Sheet No.: \_\_\_\_\_ Job No.: \_\_\_\_\_  
 Contractor: \_\_\_\_\_ Project: \_\_\_\_\_

Test Location <sup>a</sup> and Remarks <sup>b</sup>	<input type="checkbox"/> Subgrade		<input type="checkbox"/> Foundation	
		Depth <sup>c</sup>		
	Dial Reading <sup>d</sup>			
	IBV			
	Q <sub>u</sub>			
	Depth			
	Dial Reading			
	IBV			
	Q <sub>u</sub>			
	Depth			
	Dial Reading			
	IBV			
	Q <sub>u</sub>			
	Depth			
	Dial Reading			
	IBV			
	Q <sub>u</sub>			
	Depth			
	Dial Reading			
	IBV			
	Q <sub>u</sub>			

<sup>a</sup> Indicate station and offset.  
<sup>b</sup> Include soil type, moisture, rutting, or cut/fill information as applicable.  
<sup>c</sup> Depth is cumulative in inches.  
<sup>d</sup> Dial Reading = Cone Index (CI)

IBV = CI ÷ 40  
 Q<sub>u</sub> (tsf) = 0.32 x IBV

Comments:  
 Printed 10/20/2014

Cone Index	IBV	Q <sub>u</sub> *
320	8	2.6
280	7	2.2
240	6	1.9
200	5	1.6
160	4	1.3
120	3	1.0
80	2	0.6
40	1	0.3

\*Q<sub>u</sub> value calculated from IBV whole number.

BMPR SL31 (Rev. 03/17/10)



Field Soil Compaction (Nuclear)

Inspector No.(2): \_\_\_\_\_ Contract No.(3): \_\_\_\_\_ Job No.(4): \_\_\_\_\_  
 Responsible Loc(5): \_\_\_\_\_ Lab(6): \_\_\_\_\_ Lab Name(7): \_\_\_\_\_  
 Sub Contractor(8): \_\_\_\_\_ Producer Code(9): \_\_\_\_\_ Material Code(10): \_\_\_\_\_

Test Id No.(1): \_\_\_\_\_

Test Date(11):	Test No.(12):	Station (13):	Ref (14):	Type Const(15):	Type Insp(16):	Original Id No.(17):	Grnd	Elevation(18): Grade	Test
A									
B									
C									
D									
E									
F									
G									

Material Source(19):	Soil Type(20):	Test Method(21):	Opt H.O(22):	Actual H.O(23):	% Opt(24):	Std Proc(25):	Actual Dens(26):	% Std(27):	Min Spec(28):	Results (29):
A										
B										
C										
D										
E										
F										
G										

\*Note: All test data that is stored in MISTIC must be metric. If the data on the form is in English units, then type "Y" in the convert field "C(30)" and the MISTIC system will convert it to Metric values after processing. If the data on the form is in metric units, then leave blank. \*C(30): \_\_\_\_\_

	A	B	C	D	E	F	G
(31): Moisture Reading							
(32): Moisture Standard Count, C.P.M.							
(33): Moisture Count Ratio (31 ÷ 32)							
(34): Density Reading							
(35): Density Standard Count, C.P.M.							
(36): Density Count Ratio (34 ÷ 35)							
(37): Gauge Wet Density, lb/ft <sup>3</sup>							
(38): Field Moisture, lb/ft <sup>3</sup> (Gauge + 41 or Oven Dry)							
(39): Field Dry Density, lb/ft <sup>3</sup> (37 - 38)							
(40): Field % Moisture (38 ÷ 39) X 100							
(41): Moisture Correction Factor (MCF), lb/ft <sup>3</sup>							
(42): Weight of Proctor Mold + Soil, grams							
(43): Weight of Proctor Mold, grams							
(44): Net Weight of Soil, grams (42 - 43)							
(45): Proctor Wet Density, lb/ft <sup>3</sup> (44 X Mold Factor)							
(46): Proctor Dry Density, lb/ft <sup>3</sup> (45 ÷ (52+100)) X 100							
(47): Wet Soil + Pan, grams							
(48): Dry Soil + Pan, grams							
(49): Water Loss, grams (47 - 48)							
(50): Pan Weight, grams							
(51): Dry Soil, grams (48 - 50)							
(52): Proctor % Moisture (49 ÷ 51) X 100							

Remarks(53): \_\_\_\_\_  
 MISTIC Input Date(54): \_\_\_\_\_ Copies(56): \_\_\_\_\_ Resident(57): \_\_\_\_\_

**IDH TEXTURAL CLASSIFICATION CHART**

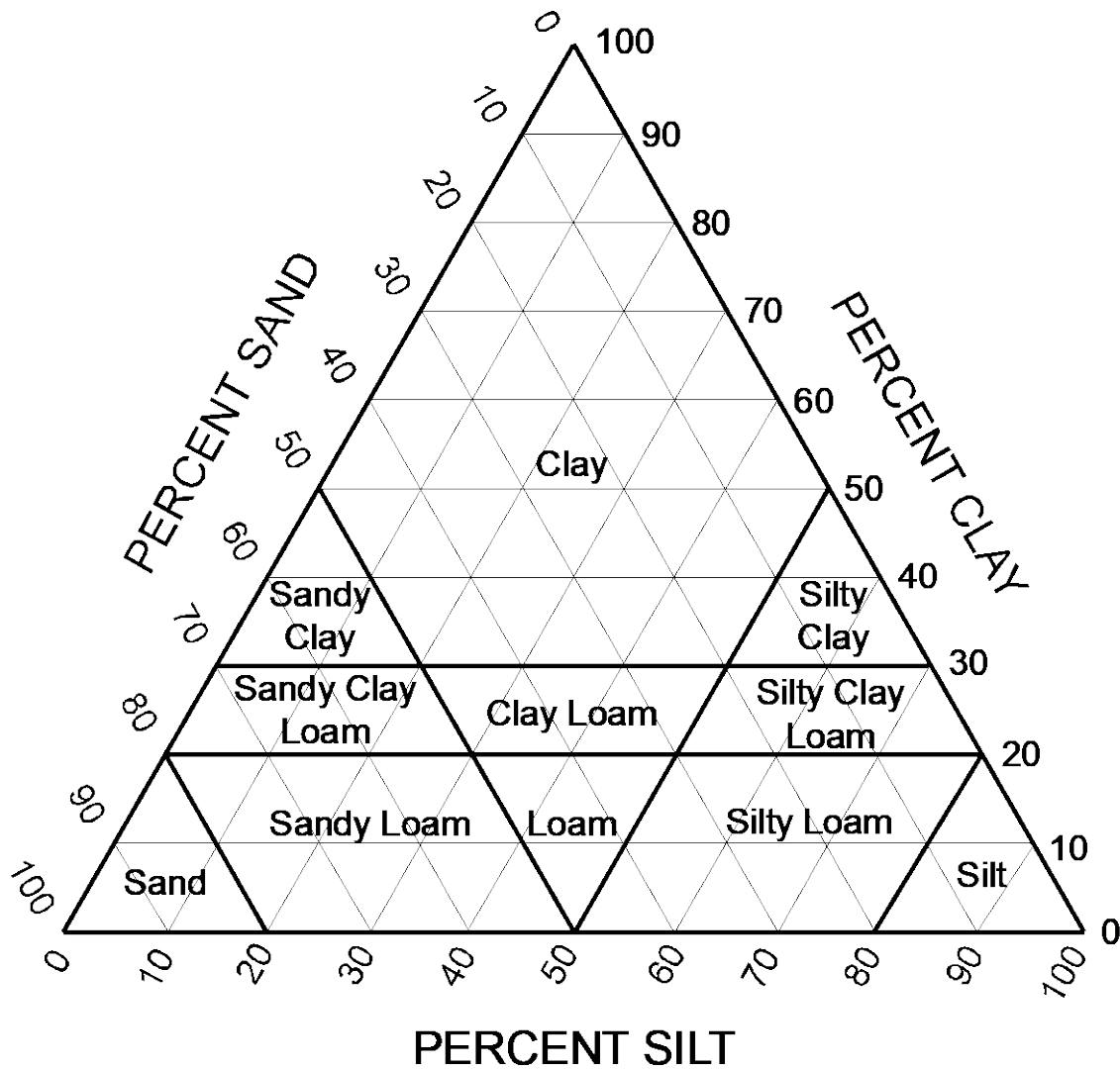

**SIZE LIMITS**

SAND: 2.0 to 0.074 mm    SILT: 0.074 to 0.002 mm    CLAY: Below 0.002 mm

**Soil Type Abbreviations**

- |                  |                        |
|------------------|------------------------|
| Sa = Sand        | SaCL = Sandy Clay Loam |
| Si = Silt        | SaL = Sandy Loam       |
| C = Clay         | SiC = Silty Clay       |
| L = Loam         | SiL = Silty Loam       |
| SaC = Sandy Clay | SiCL = Silty Clay Loam |
|                  | CL = Clay Loam         |

**SIMPLIFIED FLOW CHART FOR FIELD IDENTIFICATION OF SOILS**

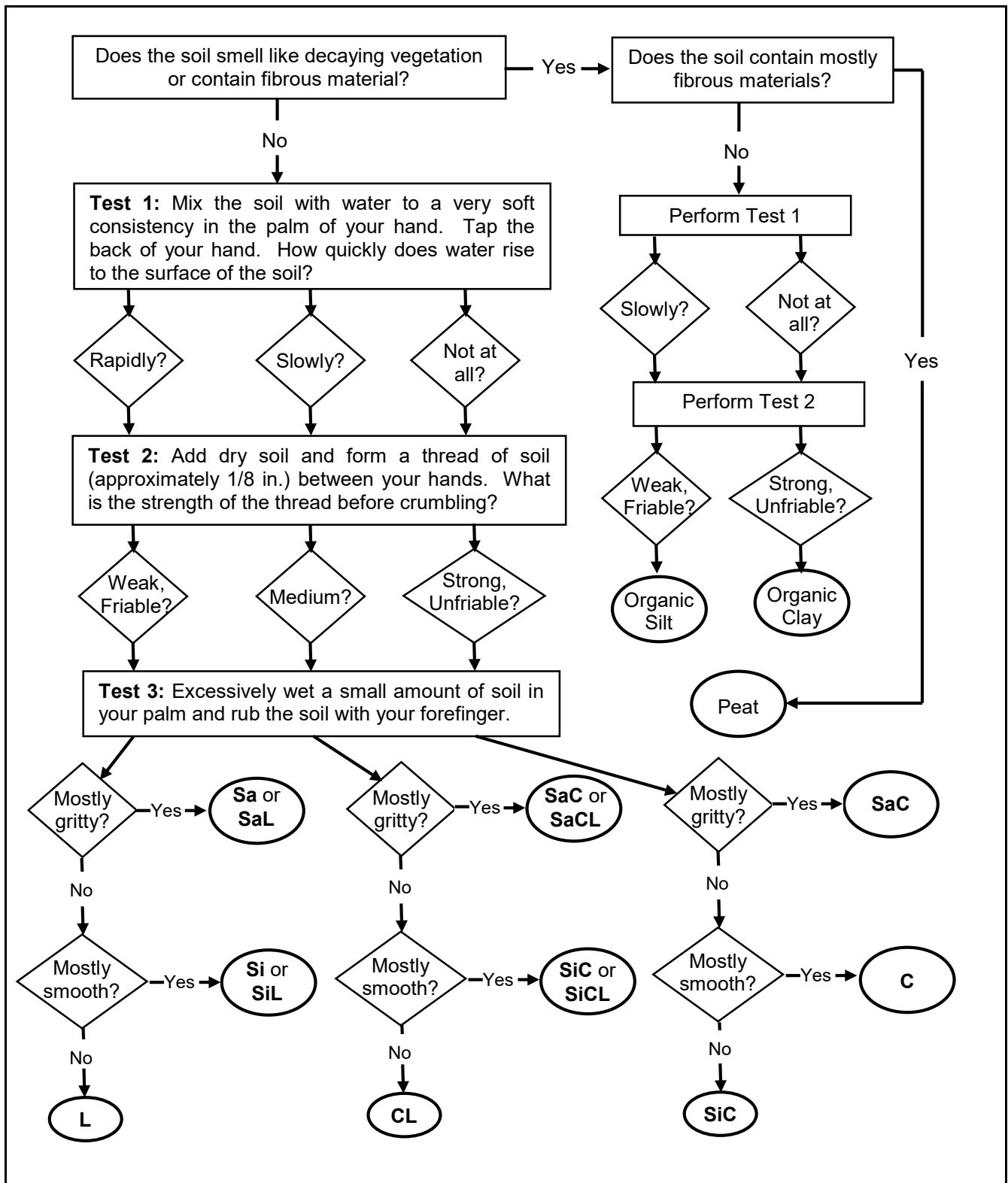

## NOTES