

**TYPICAL FABRIC FORMED CONCRETE REVETMENT MAT LINED DITCH**

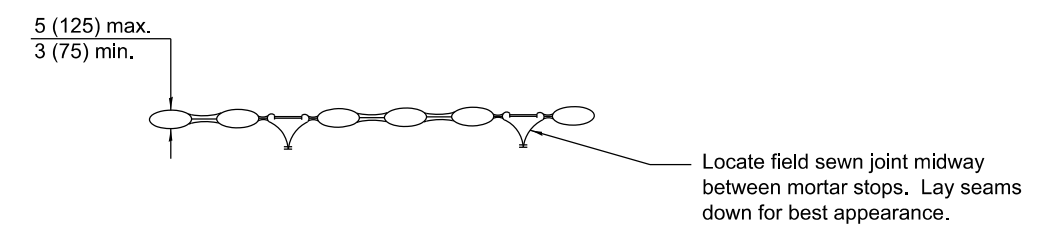

**TYPICAL SECTION THRU FILTER POINT MAT**

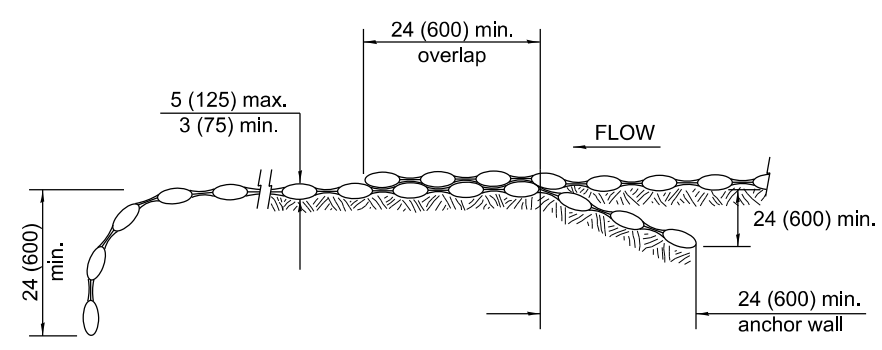

**CUT OFF WALL DETAILS**

**TYPICAL LAP JOINTS W/ANCHOR WALL**

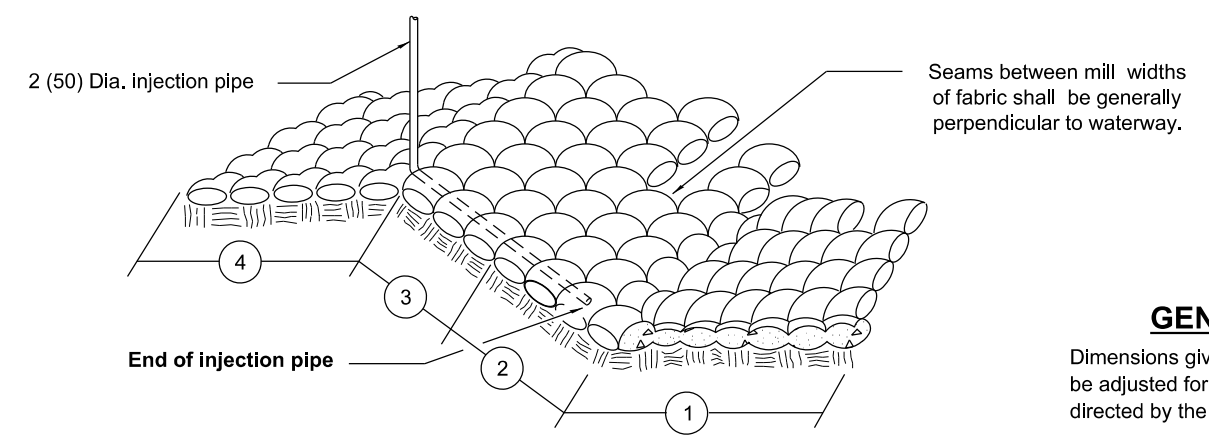

**INSTALLATION DETAILS**

1. In placing inserts through fabric use care to avoid breaking drop stitches.
2. ① Indicates sequence of pour.

**GENERAL NOTES**

Dimensions given with minimum limits shall be adjusted for field conditions as directed by the Engineer.

All anchor walls on side slopes and at lap joints, as well as cut off walls, shall be installed in trenches.

Cut off walls shall be installed at the upstream and downstream ends.

All dimensions are in inches (millimeters) unless otherwise shown.

Illinois Department of Transportation

APPROVED January 1, 2008  
*Scott S. [Signature]*  
 ENGINEER OF POLICY AND PROCEDURES

APPROVED January 1, 2008  
*Lee E. Han*  
 ENGINEER OF DESIGN AND ENVIRONMENT

ISSUED 1-1-97

DATE	REVISIONS
1-1-08	Switched units to English (metric).
1-1-02	Revised second note.

**FABRIC FORMED CONCRETE REVETMENT MATS**

**STANDARD 285001-02**