

**PLAN**

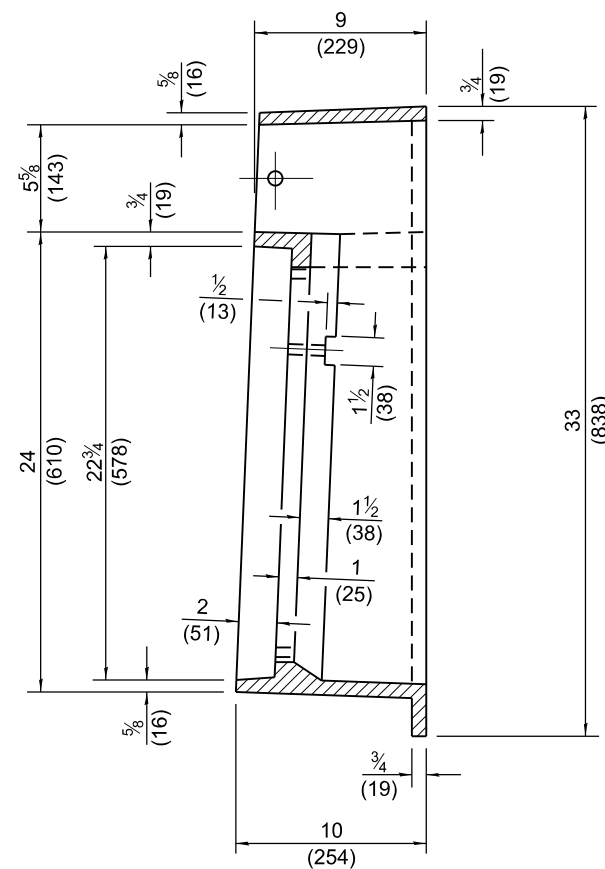

**SECTION B-B**

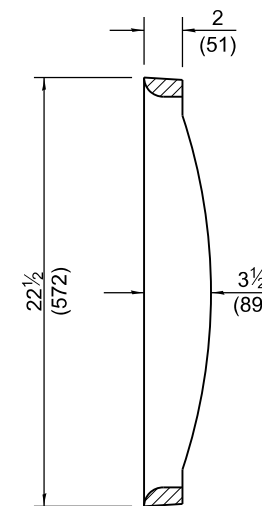

**SECTION D-D**

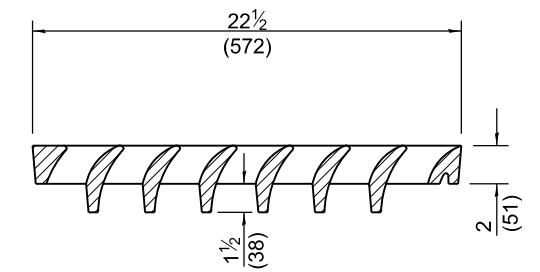

**SECTION C-C**

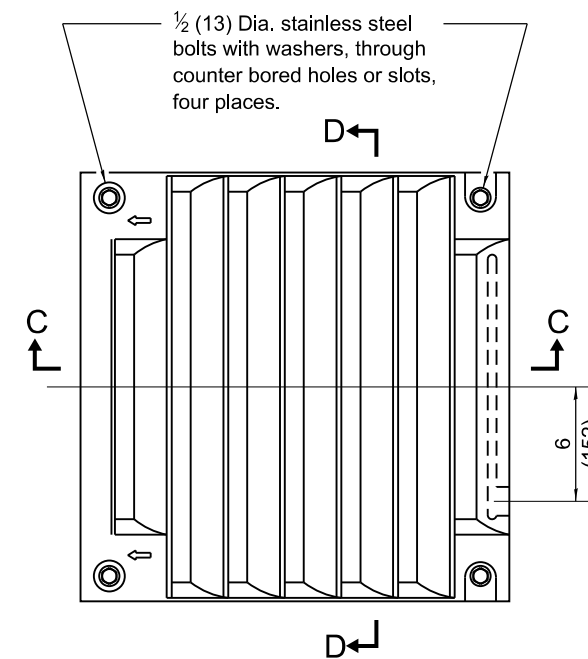

**CAST GRATE**

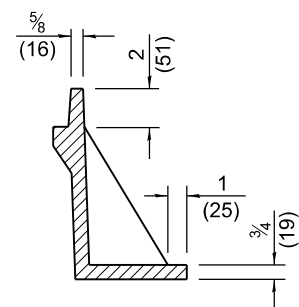

**SECTION A-A**

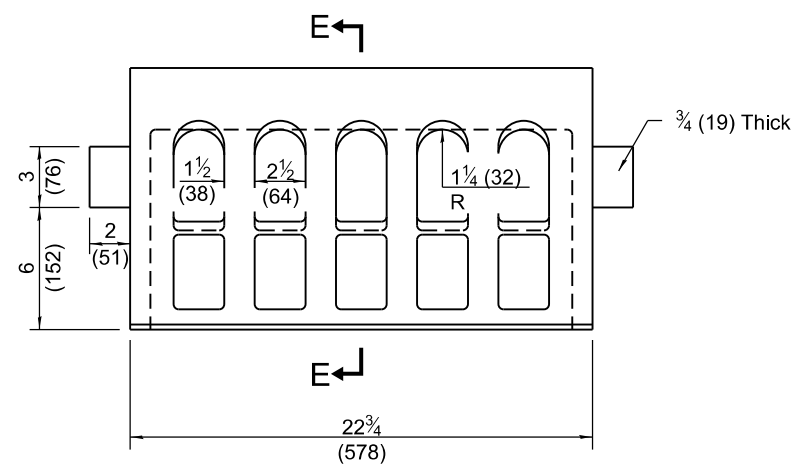

**CURB BOX**

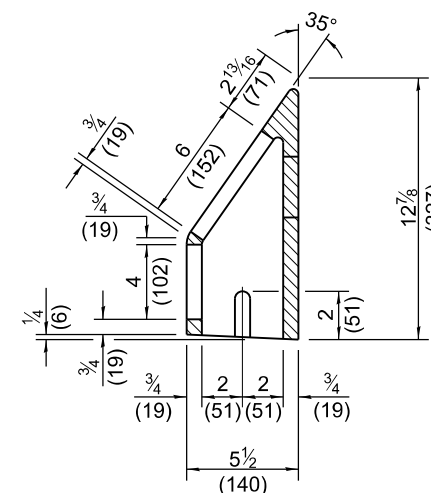

**SECTION E-E**

All dimensions are in inches (millimeters) unless otherwise shown.

DATE	REVISIONS
1-1-22	Removed slots in frame which held the "safety bar".
1-1-21	Removed "safety bar" from frame.

**FRAME AND GRATE  
TYPE 21**

**STANDARD 604076-06**

Illinois Department of Transportation

APPROVED January 1, 2022  
*Michael Beard*  
ENGINEER OF POLICY AND PROCEDURES

APPROVED January 1, 2022  
*John Che*  
ENGINEER OF DESIGN AND ENVIRONMENT

ISSUED 1-1-97