

PLAN

CAST FRAME

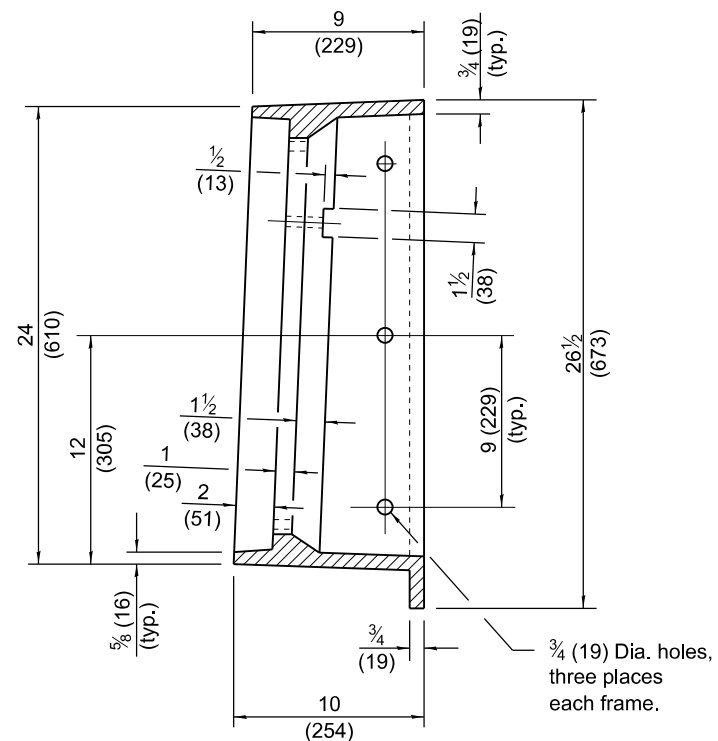

SECTION B-B

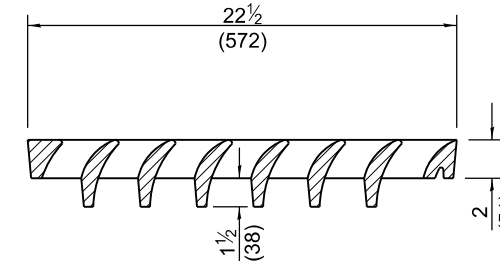

SECTION C-C

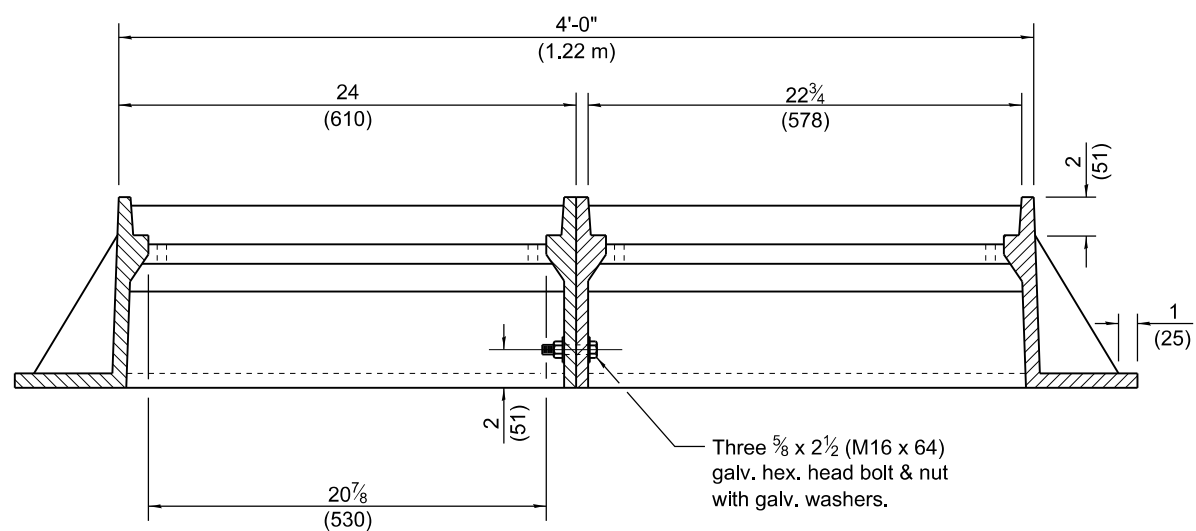

SECTION A-A

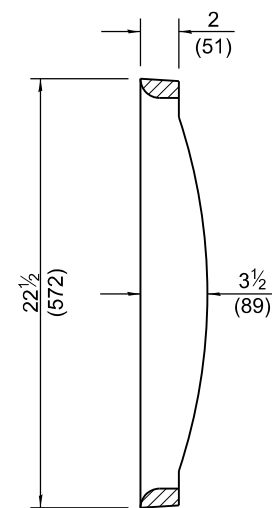

SECTION D-D

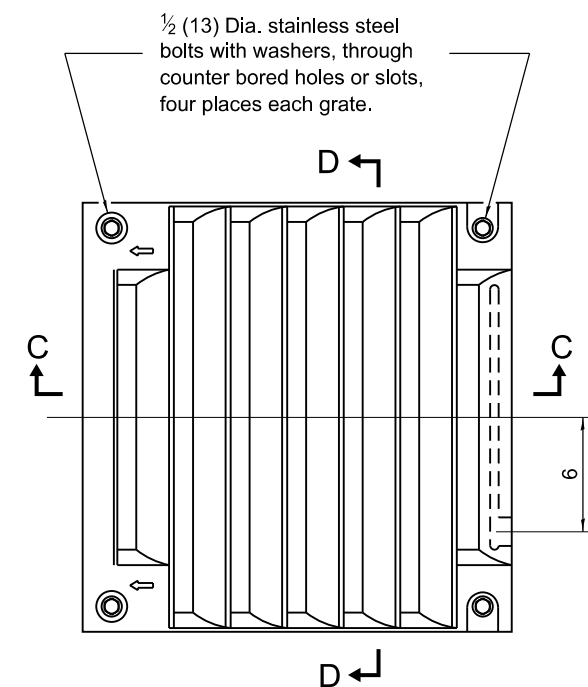

CAST GRATE

All dimensions are in inches (millimeters) unless otherwise shown.

Illinois Department of Transportation

APPROVED January 1, 2022

Michael Beard
ENGINEER OF POLICY AND PROCEDURES

APPROVED January 1, 2022

Scott Che
ENGINEER OF DESIGN AND ENVIRONMENT

ISSUED 1-1-97

DATE	REVISIONS
1-1-22	Removed slots in frame which held the "safety bar".
1-1-21	Removed "safety bar" from frame.

**FRAMES AND GRATES
TYPE 22**

STANDARD 604081-06