

**2 LANE**

**MULTI LANE**

**LANE AND EDGE LINES**

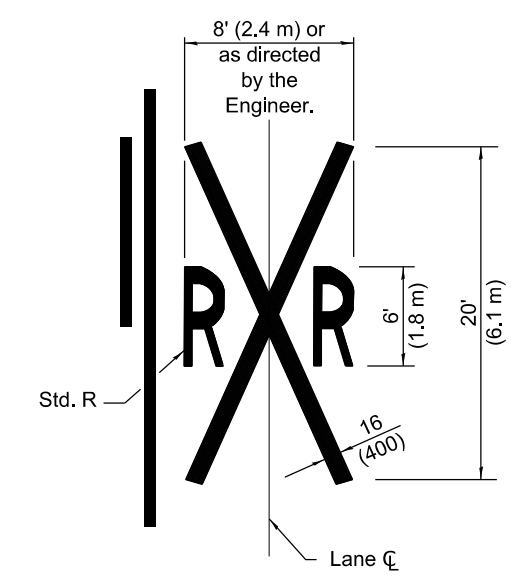
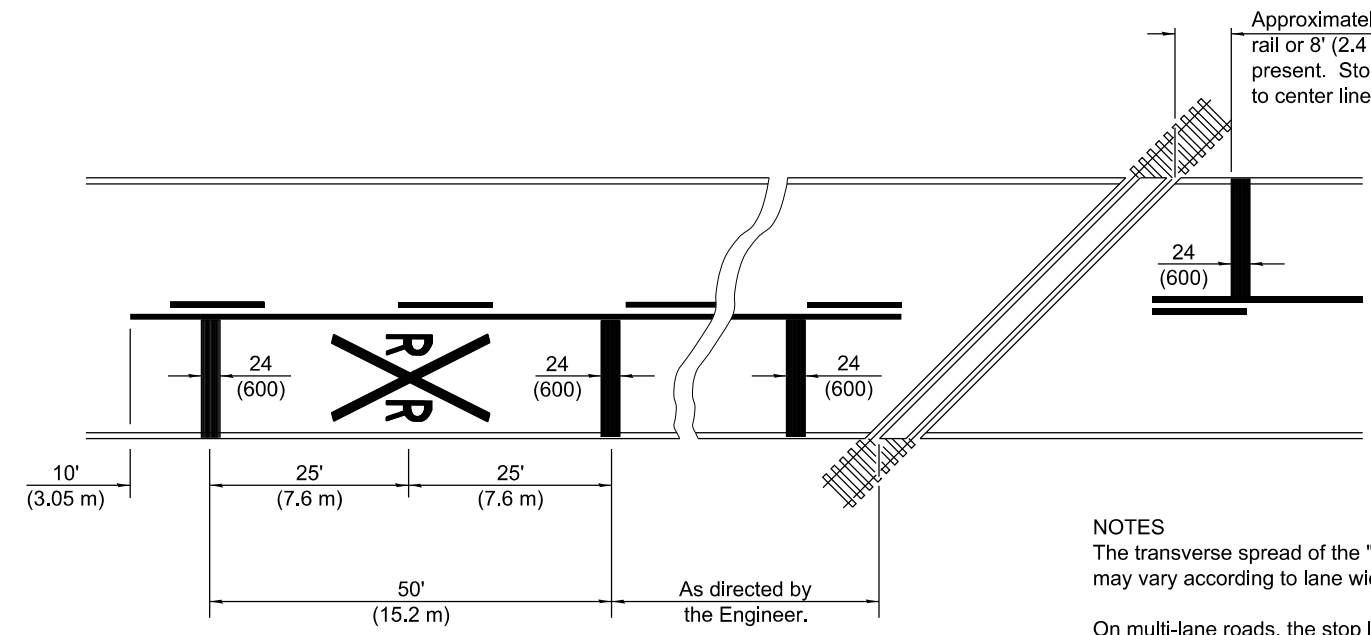

**NOTES**

The transverse spread of the "X" may vary according to lane width.

On multi-lane roads, the stop lines shall extend across all approach lanes and separate RXR symbols shall be placed adjacent to each other in each lane.

When the pavement marking symbol is used, a portion of the symbol should be located directly adjacent to the Advance Warning Sign (W10-1) as placed by Table 2C-4, Condition B of the MUTCD.

All dimensions are in inches (millimeters) unless otherwise shown.

**PAVEMENT MARKINGS AT RAILROAD-HIGHWAY GRADE CROSSING**

DATE	REVISIONS
1-1-15	Added symbols. Revised bike symbol.
	Revised note for stop line at RR crossing.
1-1-14	Added bike symbol. Renamed 'LANE
	DROP ARROW' detail to 'LANE-
	REDUCTION ARROW'.

**TYPICAL PAVEMENT MARKINGS**

(Sheet 1 of 3)

**STANDARD 780001-05**

Illinois Department of Transportation

APPROVED January 1, 2015  
*Amy Ellis*  
 ENGINEER OF OPERATIONS

APPROVED January 1, 2015  
*[Signature]*  
 ENGINEER OF DESIGN AND ENVIRONMENT

ISSUED 1-1-97

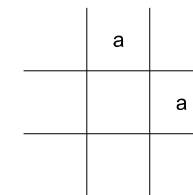
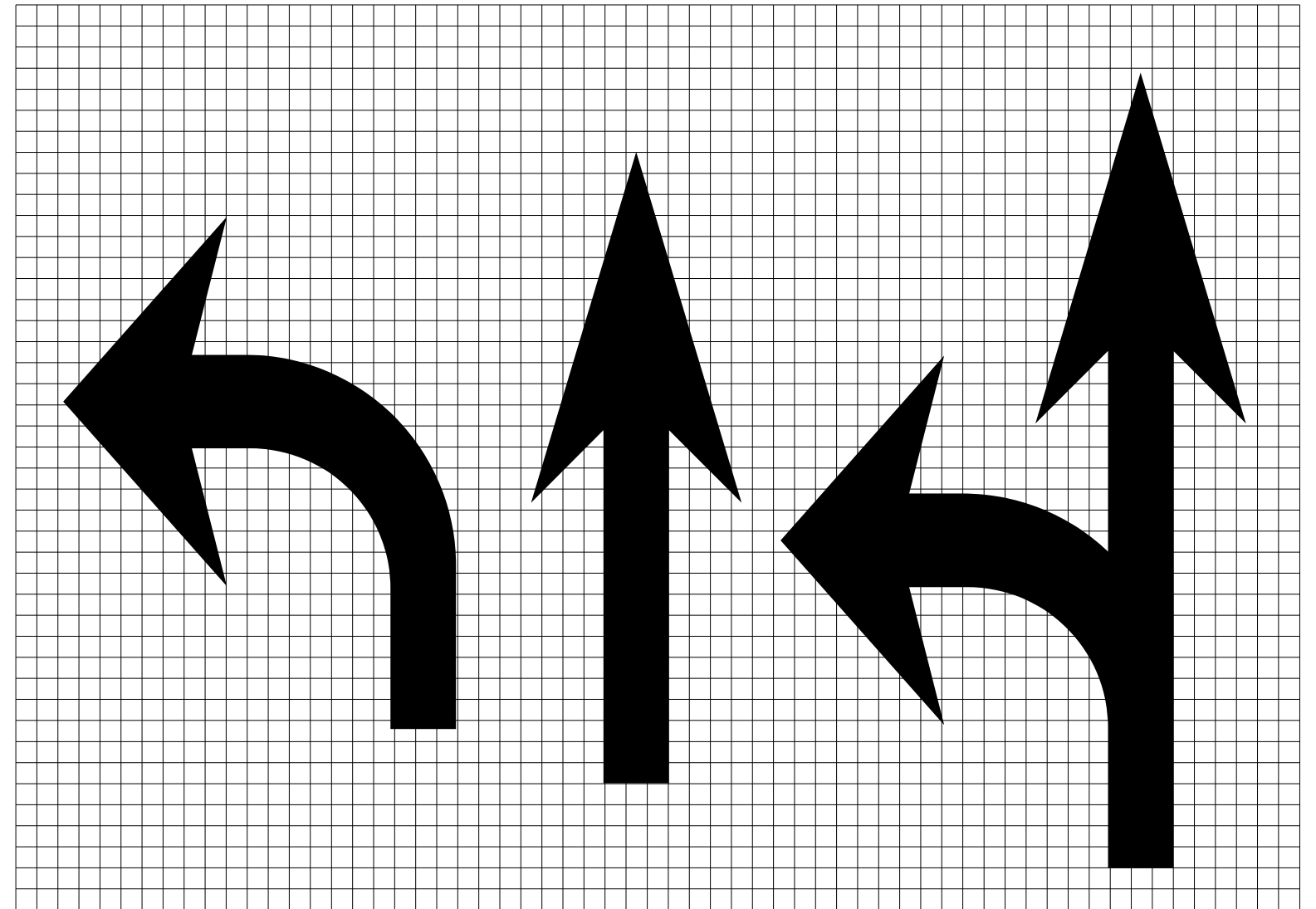

Legend Height	Arrow Size	a
6' (1.8 m)	Small	2.9 (74)
8' (2.4 m)	Large	3.8 (96)

The space between adjacent letters or numerals should be approximately 3 (75) for 6' (1.8 m) legend and 4 (100) for 8' (2.4 m) legend.

**LETTER AND ARROW GRID SCALE**

 Illinois Department of Transportation  
 APPROVED January 1, 2015  
*Amy Ellis*  
 ENGINEER OF OPERATIONS  
 APPROVED January 1, 2015  
*RE*  
 ENGINEER OF DESIGN AND ENVIRONMENT

ISSUED 1-1-97

**TYPICAL PAVEMENT MARKINGS**  
 (Sheet 2 of 3)  
**STANDARD 780001-05**

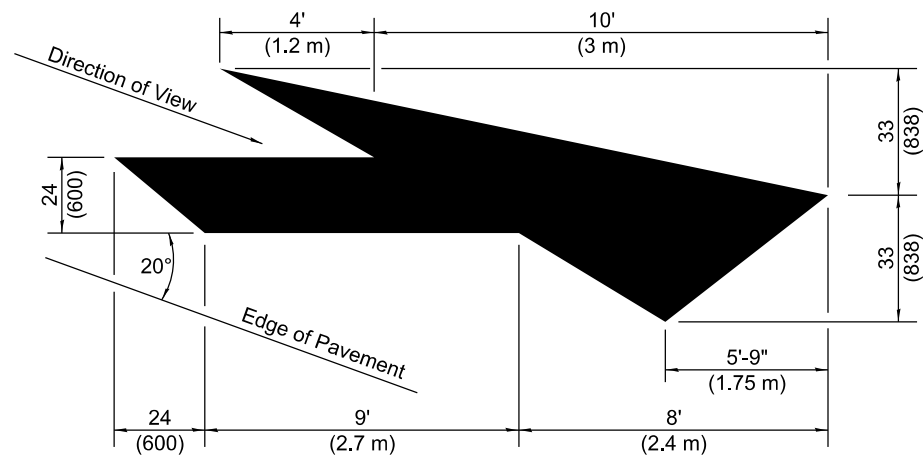

**LANE-REDUCTION ARROW**

Right lane-reduction arrow shown.  
Use mirror image for left lane.

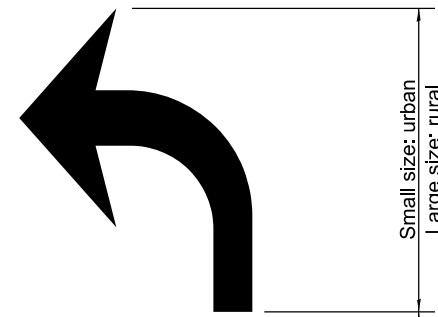

20' (6 m): urban  
50' (15 m): rural  
(Between arrow  
and word or  
between words)



**WORD AND ARROW LAYOUT**

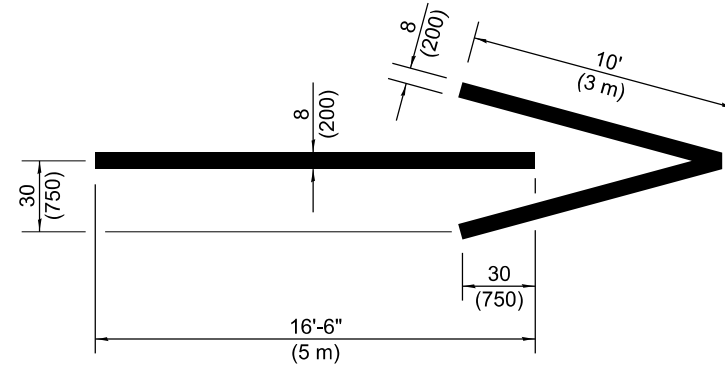

**WRONG WAY ARROW**

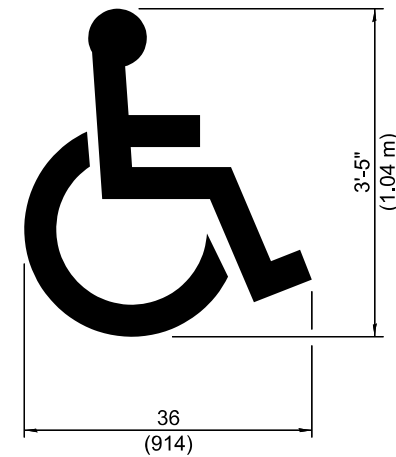

**INTERNATIONAL  
SYMBOL OF  
ACCESSIBILITY**

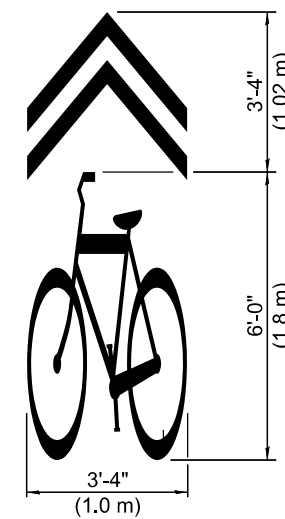

**SHARED LANE  
SYMBOL**

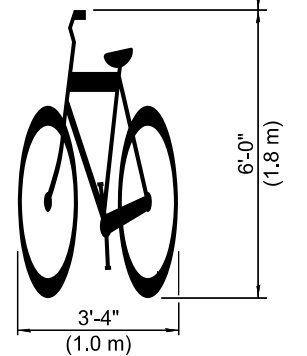
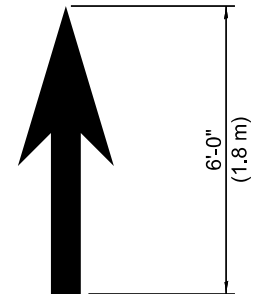

**BIKE SYMBOL**  
(Arrow is optional.)

Illinois Department of Transportation

APPROVED January 1, 2015  
*Amy Ellis*  
ENGINEER OF OPERATIONS

APPROVED January 1, 2015  
*[Signature]*  
ENGINEER OF DESIGN AND ENVIRONMENT

ISSUED 1-1-97

**TYPICAL PAVEMENT  
MARKINGS**

(Sheet 3 of 3)

**STANDARD 780001-05**