

BONDING A HANDHOLE COVER & FRAME

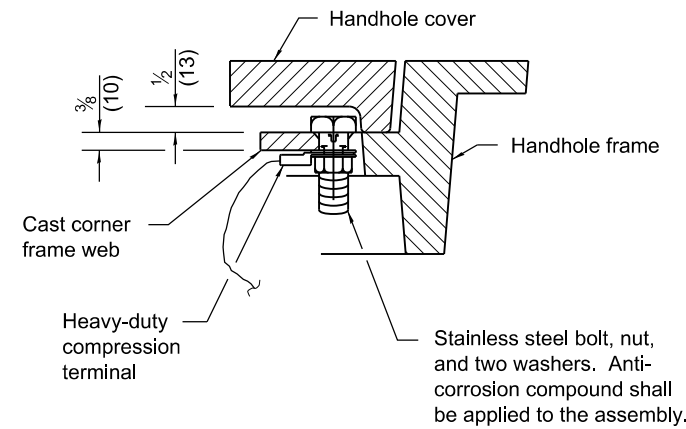

DETAIL "A"

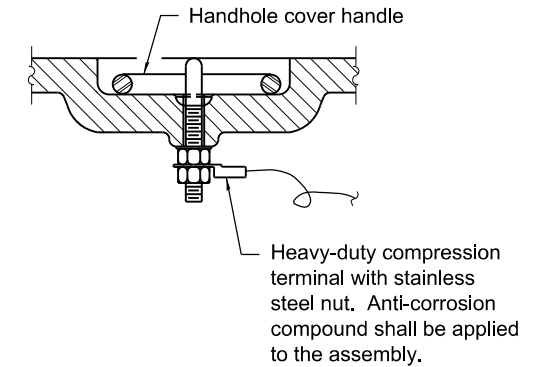

DETAIL "B"

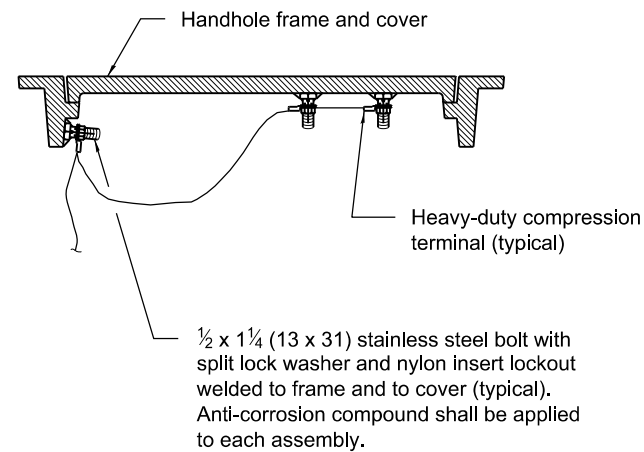

BONDING AN EXISTING HANDHOLE COVER & FRAME

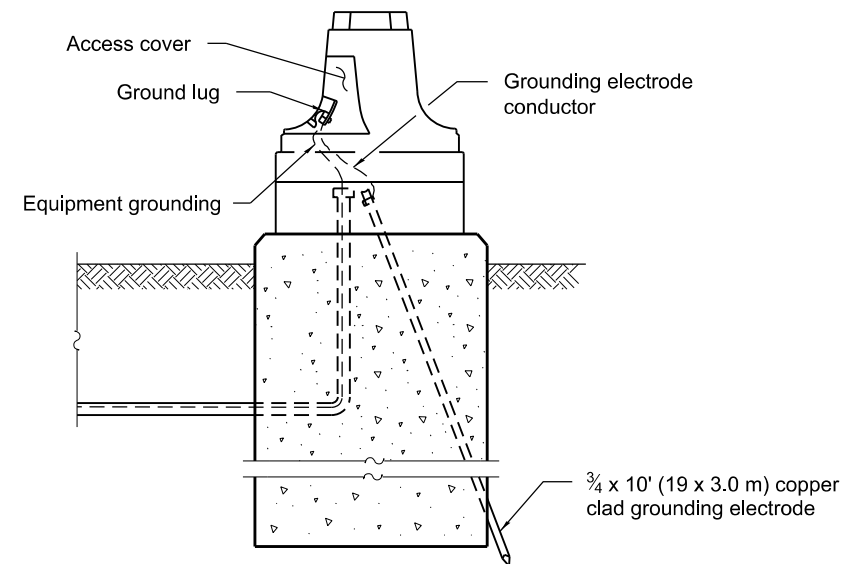

GROUNDING A MAST ARM POLE/POST



HEAVY-DUTY COMPRESSION TERMINAL

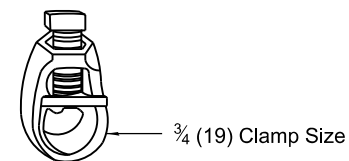

HEAVY-DUTY GROUND ROD CLAMP

All dimensions are in inches (millimeters) unless otherwise shown.

Illinois Department of Transportation

APPROVED January 1, 2009

 ENGINEER OF OPERATIONS

APPROVED January 1, 2009

 ENGINEER OF DESIGN AND ENVIRONMENT

ISSUED 4-1-06

DATE	REVISIONS
1-1-09	Switched units to English (metric).
1-1-07	Revised terminology.

**TRAFFIC SIGNAL
GROUNDING & BONDING**

STANDARD 873001-02