

PROCEDURE MANUAL

04-01



MICHIGAN STATE POLICE

Department Uniforms

Purpose: This manual provides guidance and procedures on uniforms for enforcement members, including the classifications of uniforms, the equipment required, display and use.

Effective Date: March 15, 2024

Supersedes: Procedure Manual 04-01, dated April 19, 2022

Table of Contents

Department Uniforms

Section 1: Uniforms	2
1.1 Uniform Classifications	2
1.2 Uniform Equipment	4
1.3 Designation of Rank and Time in Service	7
1.4 Wearing Individual Awards	7
1.5 Duplicate Badges	7
1.6 Care of Uniform	8
1.7 Replacing Lost Personal Issue Items	9
1.8 Disposal of Uniform Equipment	9
Section 2: Wearing Uniform Accouterments	11
2.1 Accouterment Finishes	11
2.2 Badges	11
2.3 Name Bar	12
2.4 Tie Bar	12
2.5 Specialist Identification Ribbons	12
2.6 Department Award Ribbons	13
2.7 Whistle Chain	14
2.8 Pens	14
2.9 Collar Insignias (Class A, B, and C Uniforms)	15
2.10 Commissioned Officer Shoulder Insignia (Class A Uniform)	16
2.11 Class D (Fatigue) Uniform	17
5.12 Mourning Bands and Pins	18
Section 3: Distribution Center Issued Equipment	18
3.1 Uniforms	19
3.2 Special Issue Items	19
3.3 Distribution Center Issue Equipment	19
Section 4: Special Items Approved to Wear with the Uniform	27
4.1 Approved Uniform Items	27
Section 5: Uniforms Reference Materials	30
5.1 Uniforms for Enlisted Members	30
5.2 Uniforms for Motor Carrier Officers	30
5.3 Uniforms for State Properties Security Officers	30

Definitions:

None

Section 1: Uniforms

1.1 Uniform Classifications

a. Class A Uniform

The Class A uniform is the dress uniform worn for special occasions. It consists of the uniform garrison hat, dress blouse, long-sleeve shirt, tie, winter trousers, and oxfords or shined issued boots with clean soles. The duty belt (Sam Browne) is worn with the shoulder strap.

- i. From the second Sunday in November until the third Sunday in March, the Class A uniform shall be worn by an enlisted member, motor carrier officer, or state properties security officer only under the following circumstances:
 1. When giving a formal presentation or speech
 2. When representing the department at a funeral or memorial service
 3. When attending a departmental ceremony
 4. When attending a formal event as determined by the district/division or bureau commander
 5. At other times when directed by the respective bureau commander
- ii. If the occasion to wear the Class A uniform as specified above is for a duration less than an entire shift, the enforcement member shall wear the uniform of the day for the balance of their shift.
- iii. The wearing of the Class A uniform outside of the dates specified above shall require approval of the Director or Director's designee.

b. Class B Uniform

The Class B uniform is the winter uniform typically worn by enforcement members for general patrol, administrative, and other duties. It consists of the uniform garrison hat or winter hat, long-sleeve shirt, tie, winter trousers, car-duty jacket, parka, or overcoat. Oxfords or boots may be worn, but if boots are chosen, they shall be worn under the pant leg. The duty belt (Sam Browne) is worn without the shoulder strap.

The Class B uniform shall be the uniform of the day from the first Sunday in October through the first Sunday in May.

c. Class C Uniform

The Class C uniform is the summer uniform typically worn by enforcement members for general patrol, administrative, and other duties. It consists of the uniform garrison hat, short-sleeve shirt, tie, and summer or winter trousers, and car-duty jacket. Oxfords or boots may be worn,

but if boots are chosen, they shall be worn under the pant leg. The duty belt is worn without the shoulder strap.

The Class C uniform shall be the uniform of the day from the first Sunday in May through the first Sunday in October.

d. Class D Uniform

- i. The Class D Uniform is the fatigue uniform. It is worn by specialists such as Emergency Support Team members, canine handlers, Office of Behavioral Science members, some crime lab personnel, other specialty team members, and by all enlisted members for training and other special duty. It consists of the fatigue cap, fatigue pants and shirt, and field duty boots. The duty belt (Sam Browne) is worn without the shoulder strap.
- ii. The Class D uniform is to be worn only under the following circumstances:
 1. The Class D uniform shall be worn by motor carrier officers during all enforcement activities.
 2. The wearing of the issued knit stocking cap is authorized for motor carrier officers, while on patrol.
 3. The Class D uniform shall be worn by enlisted and state properties security officers only for non-patrol activities, and when details and assignments make it necessary, and then only with permission of the worksite commander or higher authority.
 4. Specialty team members shall not wear the Class D uniform during patrol duties in their day-to-day assignments outside their specialty area.
 5. When worn, the determination of wearing Class D long or short sleeve shirts shall be consistent with the uniform of the day for Class B or C uniforms, unless tactical, environmental, or operational concerns dictate otherwise.
 6. The Class D uniform shall be taken on mobilizations, but shall only be worn when directed by the incident commander.
 7. A dark blue or black crew neck shirt shall be worn under the Class D uniform shirt.
 8. A dark blue or black turtleneck shirt may be worn under the Class D uniform shirt by specialty team members, providing all members are consistent and wear the same type of shirt when conducting a team operation or training.
 9. Athletic shoes may only be worn with the Class D uniform in the following situations:
 - a) When training within Training Division facilities or on Training Division property.
 - b) When the training or activity is conducted primarily indoors, unless that training or activity is for the purpose of civil disorder control, or when wearing the field duty boot is an integral part of that training.

- c) While in transit to and from such activity, field duty boots shall be worn with the Class D uniform.
10. When worn with the field duty boots, the Class D uniform shall be worn with the pant legs tucked into the boots and bloused.
11. Designation of rank shall not be worn on the Class D fatigue hat.
12. Only commissioned officers and sergeants shall wear rank insignia on the Class D uniform and they shall do so in accordance with Section 2 of this Order.
13. Canine handlers, when engaged in a tracking assignment, are exempt from wearing the Class D fatigue hat.
14. See Section 5 for photographic representations of the proper wear of the Class D uniform, and Section 2 for information on the proper wear of patches and collar insignia on the Class D uniform.
15. Camouflage fatigue uniforms and related equipment worn by Emergency Support Team members and canine handlers shall be worn in accordance with each unit's respective policies and procedures.
16. Members of the Office of Behavioral Science may wear the Class D uniform when responding to and from, and assisting at, the scene of an incident where their services are requested. They may also wear the Class D uniform while participating in department-sanctioned training.

1.2 Uniform Equipment

- a. Outer Garments
 - i. Car Duty Jacket
 1. Car duty jackets are intended to be worn by all uniformed members during inclement weather, unless another outer garment is worn in accordance with the Order.
 2. The only accouterment worn on the car duty jacket is the name bar as specified in Section 2.
 3. Length of service shall not be designated on the car duty jacket.
 - ii. Class A Uniform Blouse
 1. The Class A uniform blouse is the dress uniform worn for special occasions as specified in Section 1.1.
 2. Accouterments are to be worn as specified in Section 2.
 - iii. Overcoat
 1. Commissioned enlisted and motor carrier officers at the assistant district or division commander level and above shall be issued overcoats which may be worn over the Class A uniform blouse and Sam Browne belt.
 2. Accouterments are to be worn as specified in Section 2.

iv. Parka

1. Parkas shall be issued upon request to all uniformed enlisted, motor carrier officers, and state properties security officers.
2. The parka is designed to be worn when circumstances require spending an unusual length of time outdoors during extremely cold weather.
3. Uniformed enlisted and motor carrier officers wearing the Class A uniform blouse may wear the parka over the blouse and Sam Browne belt.
4. The parka shall bear the designation of rank of noncommissioned, but not commissioned enforcement members. Length of service shall not be designated on the parka.

b. Gloves

- i. Enforcement members in uniform may wear gloves in cold weather. If gloves are worn, enforcement members shall wear black gloves.
- ii. Enforcement members shall not wear gloves (e.g., leather driving gloves) with their Class C uniform.
- iii. Leather gloves do not protect enforcement members from biohazards or other dangerous chemicals and cannot be sufficiently cleaned without being ruined. Enforcement members should therefore wear latex gloves or chemical protective gloves as the circumstances of a situation dictate.
- iv. Gloves are not an issued item for enlisted members. They are issued to motor carrier and state properties security officers.

c. Uniform Footwear

- i. Although uniformed enforcement members are encouraged to wear department issued footwear, they may choose to wear footwear purchased at their own expense, such as field duty boots designed for extreme cold weather, as long as those boots have a plain toe and are constructed primarily of plain black leather.

Worksite commanders may prohibit enforcement members from wearing nonissue footwear that does not give a professional appearance or does not appear to be suitable for their assigned duties.

- ii. Motor officers assigned to the Motor Unit are exempt from the above requirement to wear their boots under the uniform pant leg when they are wearing motorcycle breeches and boots during the course of performing motorcycle duty.

d. Uniform Hat

- i. Uniformed enforcement members shall wear either their issued uniform garrison hat or winter hat at all times when outside the patrol car.
 1. Wearing hats inside patrol cars is not required.

2. Uniformed enforcement members shall exercise their best judgment about wearing their uniform garrison hat inside public buildings, but the winter hat shall not be worn in buildings.
 - a) When carrying the uniform garrison hat, it shall always be carried in the non-dominant hand.
 - ii. The issued knit stocking cap may be carried by enforcement members as a secondary winter hat and worn during cold weather.
- e. Duty Belt and Holsters
- i. The duty belt shall be equipped with the following department issued items at all times:
 1. OC/CS Case - Positioned on the strong side to the front of the duty belt
 2. Pistol Holster - Positioned on the dominant side of the duty belt
 - a) Unauthorized holsters shall not be worn on the duty belt at any time
 3. Handcuff Case - Positioned on the support side to the rear of the duty belt
 4. Taser Holster - Positioned on the support side of the duty belt, opposite the pistol
 5. Magazine Case - Positioned on the support side to the front of the duty belt
 6. On-Holster Tourniquet Mount - Positioned to the front of the pistol holster
 - ii. All non-uniform and specialty enforcement members shall wear the tactical duty belt with the holster and service weapon on their strong side. Unauthorized tactical belts and holsters shall not be worn on the duty belt at any time.
 - iii. When on duty in uniform within a department facility, the enforcement member is not required to wear the duty belt, but may wear an alternate holster, black in color, on the uniform belt.
 - iv. Enforcement members have the option to wear the department issued collapsible baton on the duty belt in accordance with Official Order 05-11. Members electing to wear the collapsible baton shall position it to the rear of the duty belt.
- f. High-Visibility Safety Vests
- i. Per the [Code of Federal Regulations, Title 23, Part 634](#), enforcement members shall wear their issued high-visibility safety vest meeting ANSI 207 performance standard at all times when directing traffic, investigating crashes, and/or handling lane closures, obstructed roadways, and disasters while on foot within the right of way of a Federal-aid, limited-access highway.
 - ii. In addition to the federal regulations, members shall wear their issued high visibility safety vest when directing traffic, investigating crashes, and/or handling lane closures, obstructed roadways, and disasters while on foot within the right of way of any roadway.

1.3 Designation of Rank and Time in Service

- a. Collar Insignias
 - i. Collar insignias shall be issued to uniformed enforcement members for wear with the Class A, B, C, and D uniforms.
 - ii. Collar insignias shall be worn as specified in Section 2 of this manual.
- b. Shoulder Insignia

Insignia of rank shall be worn as specified in Section 2 of this manual.
- c. Time-In-Service Designators
 - i. Service stars, each denoting five years of service, and service bars, each denoting two years of service, shall be worn on the left sleeve of the Class A uniform blouse.
 - ii. The designation of length of service shall be kept current.
 - iii. The time-in-service designation for each enforcement member shall represent the total number of years served in their current position. For example, the time-in-service designation for enlisted members shall only represent the total number of years served as an enlisted member.
 - iv. See Section 2 of this manual for additional instruction on the proper wear of time-in-service designators.

1.4 Wearing Individual Awards

- a. Award ribbons and other uniform accouterments issued to uniformed members shall be worn as instructed in Section 2 of this manual.
- b. Award ribbons and other accouterments which are not issued by the department shall not be worn on or with the department uniform unless authorized by the Director. See Section 2 of this manual.
- c. Only one award ribbon of each type issued (e.g., bravery, meritorious, safe driving) shall be worn on a member's uniform at one time, regardless of how many awards have been earned.
- d. Enforcement members shall wear all awards issued to them as designated in this manual.

1.5 Duplicate Badges

- a. Enforcement members are each issued one breast badge and one hat badge. These are the only badges that shall be worn with the uniform, and the breast badge is the only badge that shall be used for on-duty identification purposes.
- b. Enlisted members who wish to purchase a duplicate badge, including a flat wallet badge, for off-duty identification purposes may do so using the following procedures:
 - i. The enlisted member shall submit a UD-079, Duplicate Badge Authorization form, through channels to the appropriate district/division commander. By signing the form, the enlisted member agrees to abide by the requirements listed on the form.

- ii. After the district/division commander approves the request, the enlisted member may purchase the duplicate badge. The enlisted member shall forward the duplicate badge and UD-079 signed by both the requester and the district/division commander to the Quartermaster.
- iii. The Quartermaster shall register the duplicate badge in the member's personal issued property and, if no number is on the duplicate badge, etch the enlisted member's issued badge number on the back of the duplicate badge and return it to the enlisted member.
- iv. The duplicate badge shall be turned over to the member's commanding officer in any instance when the member is required to relinquish their issued badge for any purpose other than promotion or retirement.
- v. The enlisted member shall follow the procedures listed in Official Order 04-06 if the duplicate badge is lost or stolen.

1.6 Care of Uniform

- a. Uniforms requiring repair shall be given immediate attention to prevent further damage and to restore them to serviceable condition. The member shall ensure that seasonal equipment is in serviceable condition when the time arrives for its use. Any piece of issued equipment in need of repair upon completion of its seasonal use shall be immediately forwarded to the Distribution Center.
- b. Uniform Garrison Hats
 - i. Garrison hats shall be spot cleaned with a damp cloth and air dried. The uniform garrison hat shall never be immersed in water or dry cleaned as damage will occur.
 - ii. Garrison hats shall not be left in a hot patrol car for extended periods of time. Prolonged exposure to extreme heat will degrade the hat.
 1. Garrison hats shall not be stored in a patrol car. Garrison hats shall be carefully stored in the enforcement member's wall locker when off duty.
 - iii. The rain cover shall be placed onto the garrison hat when there is prolonged or excessive exposure to moisture. Unnecessary exposure to rain will damage the hat.
- c. Class D Uniform (Fatigue)

The Class D uniform may be dry cleaned or laundered with the machine set at the permanent-press cycle.
- d. Leather

The appearance of all leather equipment shall be maintained by use of a good grade paste or liquid wax.
- e. Bullet-Resistant Vests

See directives regarding bullet-resistant vests care instructions for issued bullet-resistant vests.
- f. Issue Clothing

All other issue clothing, such as the car-duty jacket, Class A uniform blouse, trousers, and shirts, shall be dry cleaned.

1.7 Replacing Lost Personal Issue Items

- a. The following is a list of personal issue items that do not require a special report if lost or damaged:
 - i. Award Ribbons
 - ii. Baton Case
 - iii. Belt Keepers
 - iv. Belts
 - v. Collar Brass
 - vi. Collar Brass, State Seal
 - vii. Galoshes
 - viii. Case, Personal Chemical Repellent
 - ix. Case, Handcuff
 - x. Band, Garrison Hat
 - xi. Hat, Fatigue
 - xii. Hat, Uniform Garrison
 - xiii. Hat, Winter
 - xiv. Knit Stocking Cap
 - xv. Magazine Carrier
 - xvi. Name Bars
 - xvii. Retirement Pins (Retirees Only)
 - xviii. Riot Baton
 - xix. Shoulder Bars
 - xx. Specialist Identification Ribbons
 - xxi. Tie
 - xxii. Whistle
 - xxiii. Whistle Chain

1.8 Disposal of Uniform Equipment

- a. Department issued uniform equipment shall not be permanently provided to anyone for collections, displays, or personal use without specific written authorization from the Director.
- b. Destruction of Uniform Items

- i. Items that are not required to be returned pursuant to Section 1.8(C) below may be destroyed at the worksite if, in the opinion of the worksite commander, they are not in reusable condition:
 - 1. Car Duty Jacket
 - 2. Class A Uniform Blouse
 - 3. Coveralls
 - 4. Fatigue Uniforms
 - 5. Leather Items
 - 6. Parka
 - 7. Raincoat
 - 8. Ties
 - 9. Uniform Shirts
 - 10. Uniform Trousers
 - 11. Whistle and Chain
- ii. Shoulder patches and any other uniform patches shall be removed before disposing of clothing items.

c. Retained Uniform Items

Unless brand new and unworn, the following items may be kept by a departing member in good standing:

- i. Award Ribbons
- ii. Class D (Fatigue) Uniform Hat
- iii. Knit Stocking Cap
- iv. Collar Insignia
- v. Footwear
- vi. Name Bars
- vii. Specialist Identification Ribbons
- viii. Tie Bars

d. Returned Uniform Items

The following issued items shall not be destroyed, but instead shall be returned to the Distribution Center:

- i. Chemical Protective Overgarment (CPO)
- ii. Collapsible Baton

- iii. Handcuffs
- iv. Mobilization Bag
- v. Riot Baton
- vi. Riot/Ballistic Helmet
- vii. Complex Coordinated Attack Vest (CCAV)
- viii. Air Purifying Respirator (APR)
- e. Weapons, Badges, Bullet-Resistant Vest

The following issued items shall be returned to the department Quartermaster:

- i. Service Weapon (with Magazines)
- ii. Back-Up Weapon (with Magazines)
- iii. Hat and Breast Badges
- iv. Bullet-Resistant Vest

Department policy prohibits giving breast badges to anyone, except in the case of the death of an active enforcement member. Unless the originally assigned breast badge is lost or stolen a new breast badge will not be reissued.

Section 2: Wearing Uniform Accouterments

With the exception of Section 2.10 below, the information and instructions listed in this Order apply to the Class A, B, and C uniforms.

2.1 Accouterment Finishes

Uniform accouterments are available in gold or chrome finishes and shall be issued and worn by rank as follows:

A. Troopers and Sergeants	All Chrome Plated
B. Lieutenants	All Gold Plated
C. F/Lieutenants	Collar Brass Chrome Plated – All Other Gold Plated
D. Inspectors	Collar Brass Chrome Plated – All Other Gold Plated
E. Captains	All Gold Plated
F. Majors	All Gold Plated
G. Lieutenant Colonels	Collar Brass Chrome Plated – All Other Gold Plated
H. Colonel	All Gold Plated

2.2 Badges

- a. Uniformed members shall wear their department-issued breast badge through the eyelets provided on the uniform shirt or Class A uniform blouse, whichever is the outer vestment worn at the time. The breast badge shall not be worn on the car duty jacket or parka.
- b. Uniformed members shall wear their issued hat badge through the eyelets provided on their uniform garrison hat or winter hat, whichever one is being worn at the time.

2.3 Name Bar

- a. The name bar shall be worn on the Class B or C uniform shirt or Class A uniform blouse, whichever is the outer vestment worn at the time.
- b. Enforcement members wearing a car-duty jacket shall wear a name bar through the eyelets provided.
- c. The name bar shall be worn in plain view at all times, unless otherwise directed by the district or division commander, except that no name bar shall be worn on the overcoat, parka, or Class D uniform.
- d. If there are no eyelets provided on a garment, the name bar shall be centered on the right pocket flap one-half inch below the top of the flap.

2.4 Tie Bar

The tie bar shall be worn approximately one inch below the bottom edge of the pocket flap.

2.5 Specialist Identification Ribbons

Specialist identification ribbons shall be issued to members after obtaining certain specified qualifications.

- a. The following specialist identification ribbons have been approved for wear:
 - i. Diver
 - ii. Emergency Support Team (ES Team)
 - iii. Field Training Officer (FTO)
 - iv. Forensic Artist
 - v. K-9
 - vi. Motor Officer
 - vii. Pilot (Aviator)
 - viii. Community Service Trooper (CST)
 - ix. Recruiter
 - x. Traffic Crash Reconstruction Specialist
 - xi. Bomb Squad
 - xii. Drug Recognition Expert (DRE)
 - xiii. Tactical Bike Team
 - xiv. Executive Protection Unit
 - xv. Evidence Technician
- b. Specialist identification ribbons shall only be worn on the dress blouse or shirt, whichever is the outer vestment worn at the time.

- i. Specialist identification ribbon, Active Specialist
 - 1. When a member is active in the specialty area assigned, the identification ribbon shall be centered above the name bar, one quarter inch above the top of the right pocket flap.
 - 2. If a member is active in more than one specialty assignment, no more than two specialty ribbons may be worn over the right pocket flap.
 - 3. The two ribbons shall be worn immediately adjacent to each other so as to form a row, and shall be centered above the name bar, one quarter inch above the top of the right pocket flap.
- c. Specialist identification ribbon, Retired Specialist
 - i. If a member is no longer active in a specialty, but left the specialty in good standing, the member may wear the specialist identification ribbon.
 - ii. When the specialist identification ribbon is worn under this sub-section, the ribbon shall be worn at the end of the rank order for department awards identified in Section 2.6.
- d. The following photographs provide examples of other identification ribbons and their placement on the uniform:



2.6 Department Award Ribbons

- a. Award ribbons shall be worn on the Class A uniform blouse or uniform shirt, whichever is the outer vestment worn at the time, in rank order from the enforcement member's right to left, beginning with the highest honor.
- b. Award ribbons are ranked from highest to lowest as follows:
 - i. Valor
 - ii. Bravery

- iii. Meritorious Service
 - iv. Distinguished Service
 - v. Life Saving
 - vi. Blue Diamond, Injury in the Line of Duty
 - vii. Director's Commendation
 - viii. Trooper of the Year
 - ix. Cpl. Samuel A. Mapes
 - x. Marksmanship
 - xi. Safe Driving
 - xii. Voluntary Fitness Assessment
- c. No more than three award ribbons shall be worn in one tier. The award ribbon, or row of award ribbons, shall be centered below the official department badge.
- i. If a single tier of ribbons is worn, they shall be located one-quarter inch below the top of the pocket flap.
 - ii. If a second tier is worn, they shall be located immediately below the top tier.
 - iii. Only one award ribbon of each type issued shall be worn regardless of how many awards have been earned.
- d. Ribbon Bars
- i. Enforcement members may affix their department-issued award ribbons and specialist identification ribbons to a ribbon bar, purchased at their own expense.
 - ii. The award ribbons and specialist identification ribbons shall be horizontal, even with one another, and in the order specified above. The ribbon bar itself shall not be visible.

2.7 Whistle Chain

- a. The whistle chain shall be worn buttoned under the right epaulet of the uniform shirt or dress blouse, whichever is the outer garment worn at the time.
- b. Enforcement members may affix the department-issued whistle on the pocketed end of the whistle chain, or they may attach a single spare handcuff key in addition to, or instead of, the whistle. For tactical reasons, this spare handcuff key shall only be used in emergency situations when other, more accessible handcuff keys are not available.

2.8 Pens

- a. Enforcement members may wear one or two pens in the pen hole on the left pocket flap of the Class B or C uniform shirt.
 - i. Only the tops of pens and their pocket clips may be exposed. The pens shall otherwise be concealed within the pocket.

- ii. The color of the pens and/or their pocket clips shall be black or blue or match the color of the enforcement member's badge. Pens of any other color shall not be worn exposed.
- b. Pens shall not be worn exposed on the Class A uniform blouse.
- c. In place of one or both pens, enforcement members may wear a pen-style handcuff key with black, gold, or silver pocket-clip

2.9 Collar Insignias (Class A, B, and C Uniforms)

- a. Uniformed Non-Commissioned Enforcement Members
 - i. The "MSP" and post number (or "HQ") insignias shall be worn as shown in the following photograph, and as specified by the solid arrow measurement in the illustration below:

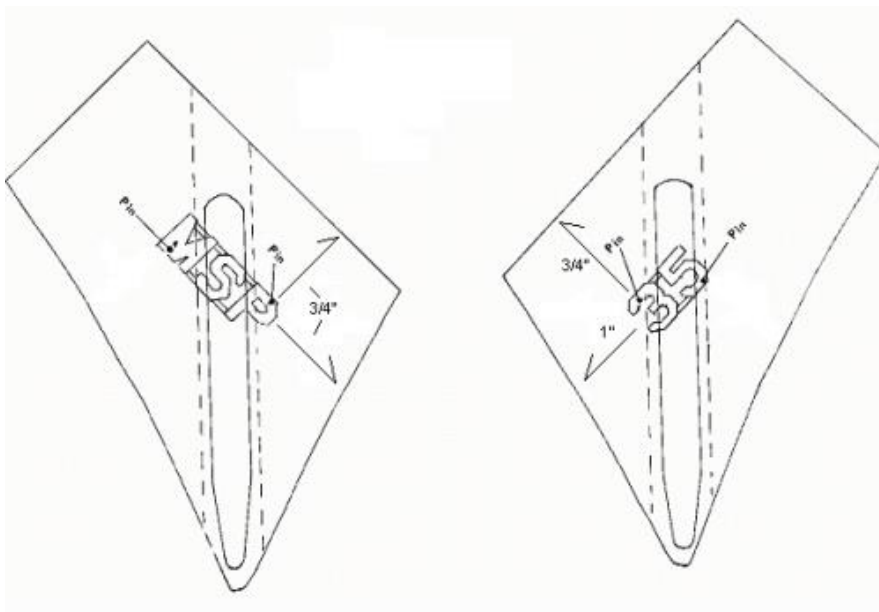

- ii. The top edge of the collar insignia shall be parallel to the top of the edge of the shirt collar.
- b. Uniformed Commissioned Enforcement Members
 - i. Lieutenants and above shall wear the post number, HQ insignia, or state seal, as appropriate for their assignment.
 - ii. The rank and state seal insignia shall be worn as shown in the following photograph, and as specified by the solid arrow measurement in the illustration below.

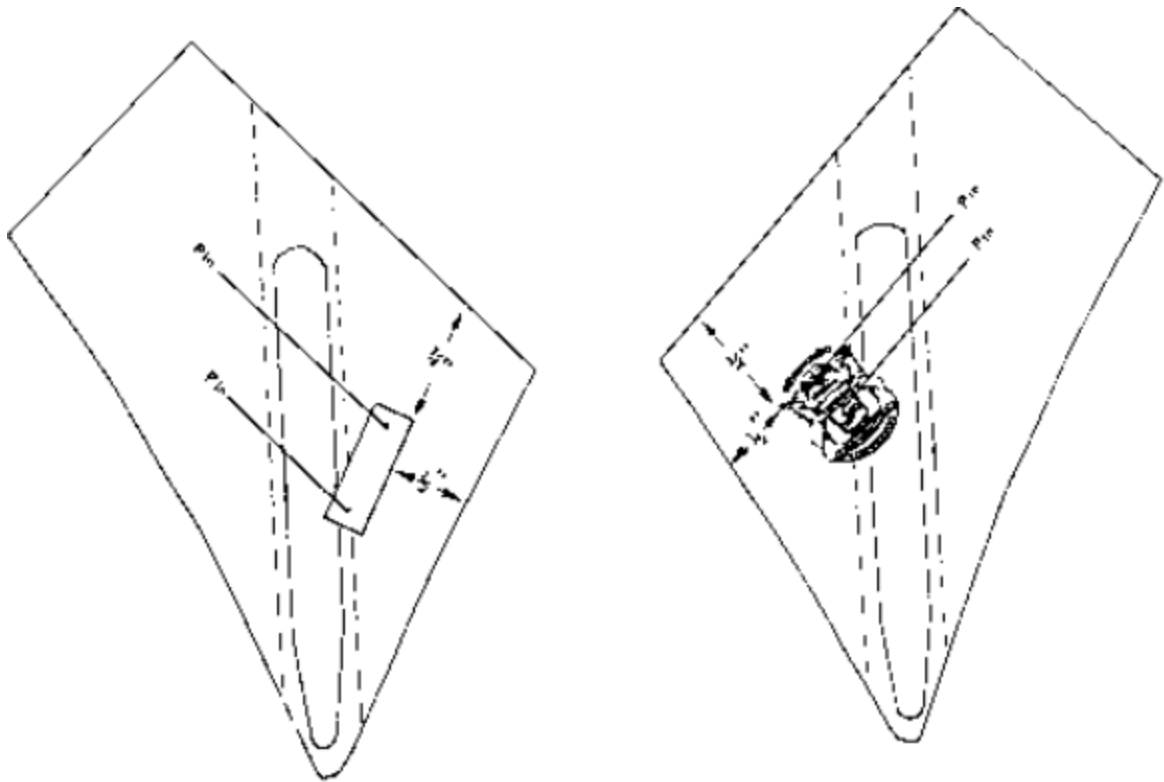

- iii. The top edge of the collar insignia shall be parallel to the top of the edge of the shirt collar.

2.10 Commissioned Officer Shoulder Insignia (Class A Uniform)

- a. Enforcement members at the lieutenant rank and higher shall wear rank insignia on the shoulders of their Class A uniform blouse.
- b. The rank insignia for colonel, lieutenant colonel, and major shall be pinned in the center of the stitched portion of each shoulder's epaulet, with the bottom of the insignia facing the shoulder seam.



- c. The rank insignia for lieutenant, first lieutenant, inspector, and captain shall be pinned in the center of the stitched portion of each shoulder's epaulet with the orientation of the bar parallel to the shoulder seam.

2.11 Class D (Fatigue) Uniform

a. Patches

- i. Subdued shoulder patches shall be worn on the Class D uniform.
- ii. Subdued Unit Patches
 1. Unit-specific subdued patches shall be issued from the Distribution Center for department members serving in specialized units.

Specialized subdued unit patches include the following:

 - a) Bomb Squad
 - b) Canine Handler
 - c) Emergency Support Team
 - d) Commercial Vehicle Enforcement
 - e) State Properties Security
 - f) Traffic Crash Reconstruction
 - g) Underwater Recovery Team
 2. Unit-specific subdued patches shall be worn centered over the left breast pocket.
 3. Approval for, and instructions for wear of, additional unit-specific subdued patches may only be granted by the Director, in cooperation with the particular unit and their respective bureau.

iii. Name Patches

1. Blank name patches shall be issued from the Distribution Center.
2. Name patches shall be worn centered over the right breast pocket.

b. Collar Insignia

- i. Sergeants

1. Sergeants shall wear subdued pin-on rank insignia on both collars of the Class D uniform.
2. The insignia shall be centered on the collars, with the centerline of the insignia bisecting the points of the collar, one inch up from the collar point, as specified in the following illustration:



- ii. Uniformed Commissioned Enforcement Members
- iii. Lieutenants shall wear subdued rank insignia on both collars of the Class D uniform. Inspectors and above are not issued subdued rank insignia.
- iv. The rank insignia shall be placed as specified in the illustration below.
- v. The top edge of the collar insignia shall be parallel to the top of the edge of the shirt collar.

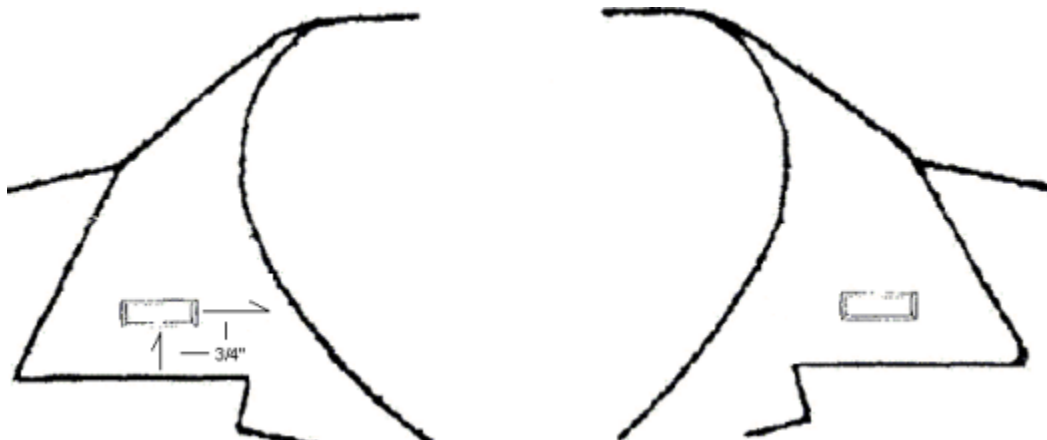

- c. Award and specialist identification ribbons, and/or metal name tags shall not be worn on the Class D uniform.

5.12 Mourning Bands and Pins

- a. Refer to PM 19-03, for guidelines on the wearing of mourning bands and pins.

Section 3: Distribution Center Issued Equipment

This section lists individual items issued by the Distribution Center to members of the department. Classifications and ranks of department members are listed to determine eligibility for issue items.

3.1 Uniforms

- a. The uniforms worn by department members are prescribed by the Director. Changes, modifications, additions, or deletions to any uniform require authorization by the Director.
- b. Members shall draw all items from the Distribution Center that may be required to be worn or carried. However, if the member has a choice in carrying/wearing an item, it is not required that they draw it. Examples of items not required to be drawn include the detective's badge holder since carrying the holder is not required, and the summer uniform trousers because a member may choose to wear only winter uniform trousers.
- c. Uniform items shall be retained by enforcement members transferred or promoted from a uniform position to non-uniform position since many of these items may not be reissued. If the officer returns to a uniform position, the original uniforms will be altered to reflect the member's new position.
- d. The Distribution Center shall issue stocked items as provided in this Order. Additional items or additional quantities of issue require written approval from the member's bureau commander before issuance.
- e. The Tailor Shop provides tailoring services for uniformed members and recruit schools. The Tailor Shop accepts appointments on Monday and Thursday between 8 a.m. and 4 p.m. (Walk in customers are taken, however appointments take priority). Members need to schedule their appointments at least one week in advance by contacting the RMU front desk at 517-636-5267.

3.2 Special Issue Items

a. Identification Cards

Members shall be issued a department identification card by the Biometrics and Identification Division.

b. Uniform Oxfords

- i. Crepe sole uniform oxfords shall be maintained as an inventory item, which may be requisitioned from the Distribution Center by members who may be issued oxfords.
- ii. Leather sole uniform oxfords are not an inventory item, but may be requested by uniformed enforcement members who are a Captain level or above in lieu of crepe sole oxfords.

3.3 Distribution Center Issue Equipment

- a. The following several pages are lists for rank/position-specific items of issued uniform equipment.

TRAINING DIVISION POLO, LONG SLEEVE	0	0	0	0	0	0	0	2*
SHOES - UNIFORM	2	2	2	2	2	2	2	0
TIE BAR	2	2	2	2	2	2	2	0
TIE, LT BLUE, CLIP-ON	3	3	3	3	3	3	0	0
TIE, DK BLUE, CLIP-ON	0	0	0	0	0	0	2	0
TIE, LT BLUE, CONVENTIONAL	0	0	0	0	3B	3B	0	0
TROUSERS, FATIGUE	1	2	2	3	1	2	1	3*
FATIGUE SUMMER PANT	0	2	2	3	0	2	0	3*
TROUSERS, SUMMER	0	0	0	0	0	0	0	0
TROUSERS, WINTER	3	3	3	3	3	3	2	0
UNIT DESIGNATION PIN	0	1	1	1	0	1	0	0
VEST, BULLET RESISTANT	1	1	1	1	1	1	1	0
WEAPON, PRIMARY	1	1	1	1	1	1	0	0
WEAPON, SECONDARY	1	1	1	1	1	1	0	0
WHISTLE & CHAIN	1	1	1	1	1	1	0	0

	UNIF SGT DIVER	UNIF SGT K-9	UNIF SGT ACC REC	UNIF SGT PREC DR INST	UNIF LT (14-15)	UNIF LT ACC REC	UNIF INSP
BADGE BY RANK	1	1	1	1	1	1	1
BADGE, MOURNING BADGE RIBBON	1	1	1	1	1	1	1
BADGE, HAT, BY RANK	1	1	1	1	1	1	1
BATON, 36" RIOT	1	1	1	1	1	1	1
BATON CASE	1	1	1	1	1L	1L	1L
BATON, COLLAPSIBLE	1	2	1	1	1L	1L	1L
BELT RETAINER	5	5	5	5	5	5	5
BELT, SAM BROWNE	1	1	1	1	1	1	1
BELT, TROUSER	1	1	1	1	1	1	1
BLOUSE, DRESS	2A	2A	2A	2A	2A	2A	2A
BOOTS, COMBAT	1	1	1	1	1	1	1
CAP, FLEECE LINED, KNIT STOCKING	1	1	1	1	1	1	1
COVERALLS, INSULATED	1	0	1	0	0	1	0
COVERALLS, PLAIN	0	0	1	0	0	1	0
GAS CASE (CHEMICAL REPELLANT)	1	1	1	1	1L	1L	1L
GAS MASK	1	1	1	1	1	1	1
HANDCUFF CASE	1	1	1	1	1	1	1
HANDCUFFS & KEYS	1	2	1	1	1	1	1
HAT BAND, GOLD OR SILVER	1	1	1	1	1	1	1
HAT, FATIGUE	1	1	1	1	1	1	1
HAT, UNIFORM GARRISON	2	2	2	2	2	2	2
HAT, WINTER	1	1	1	1	1	1	1
HELMET, RIOT	1	1	1	1	1	1	1
HIGH VISIBILITY VEST	1	1	1	1	1	1	1
HOLSTER, SERVICE WEAPON	1	1	1	1	1	1	1
INSIGNIA, COLLAR, HQ, POST #/ST SEAL	1	1	1	1	1	1	1
INSIGNIA, COLLAR, MSP OR RANK	1	1	1	1	1	1	1
INSIGNIA, RANK (BLOUSE/OVERCOAT)	0	0	0	0	2	2	4
JACKET, CAR	1	1	1	1	1	1	1
MAGAZINES (9MM)	2	2	2	2	2	2	2
NAME BAR	2	2	2	2	2	2	2
OVERCOAT	0	0	0	0	0	0	1
PARKA	1A	1A	1A	1A	1A	1A	1A

PARKA WITH SUBDUED PATCHES	0	1A	0	0	0	0	0
PATCHES, FATIGUE UNIT DESIGNATION	Y	Y	Y	Y	N	Y	N
PATCHES, SUBDUED FOR FATIGUES	N	Y	N	N	N	N	N
RAINCOAT AND GARRISON HAT COVER	1	1	1	1	1	1	1
SERVICE BARS & STARS	Y	Y	Y	Y	Y	Y	Y
SHIRT, DK BLUE, SHORT SLEEVE	3	3	3	3	3	3	3
SHIRT, DK BLUE, LONG SLEEVE	3	3	3	3	3	3	3
SHIRT, SHORT SLEEVE FATIGUE	2	3	2	2	0	2	0
SHIRT, LONG SLEEVE FATIGUE	2	3	2	2	1	2	1
SHOES - UNIFORM	2	2	2	2	2	2	2
TIE BAR	2	2	2	2	2	2	2
TIE, LT BLUE, CLIP-ON	3	3	3	3	0	0	0
TIE, LT BLUE, CONVENTIONAL	3B	3B	3B	3B	3	3	3
TROUSERS, FATIGUE	2	3	2	5	1	2	1
FATIGUE SUMMER PANT	2	3	2	5	0	2	0
TROUSERS, SUMMER	0	0	0	0	0	0	0
TROUSERS, WINTER	3	3	3	3	3	3	3
UNIT DESIGNATION PIN	1	1	1	0	0	1	0
VEST, BULLET RESISTANT	0	1	0	0	0	0	0
WEAPON, PRIMARY	1	1	1	1	1	1	1
WEAPON, SECONDARY	1	1	1	1	1	1	1
WHISTLE & CHAIN	1	1	1	1	1	1	1

	UNIF CAPT & ABOVE	DET TPR	DET SGT	DET SGT ES TEAM	SPL SGT FI	DET SGT MJTF	DET BOMB
BADGE BY RANK	1	1	1	1	1	1	1
BADGE, HAT, BY RANK	1	0		0	0	0	0
BADGE HOLDER	0	1	1	1	1	1	1
BADGE, MOURNING BADGE RIBBON	1	0	0	0	0	0	0
BATON CASE	1L	0	0	0	0	0	0
BATON, COLLAPSIBLE	1	0	0	0	0	0	0
BELT RETAINER	5	0	0	0	0	0	0
BELT, SAM BROWNE	1	0	0	0	0	0	0
BELT, TROUSER	1	1A	1A	1A	1	1A	1A
BLOUSE, DRESS	1	0	0	0	0	0	0
BOOTS, COMBAT	1	1A	1A	1	1	1A	1A
CAP, FLEECE LINED, KNIT STOCKING	1	1	1	1	1	1	1
COVERALLS, INSULATED	0	0	0	0	1G	1	0
COVERALLS, PLAIN	0	2	2	2	2G	1	1
COVERALLS, SHORT SLEEVE	0	0	0	0	1	0	0
GAS MASK	1	1	0	1	0	0	0
HANDCUFF CASE	1	0	0	0	0	0	0
HANDCUFFS & KEYS	1	1	1	2	1	1	1
HAT BAND, GOLD OR SILVER	1	0	0	0	0	0	0
HAT, FATIGUE	1	1A	1A	1A	1A	1A	1A
HAT, UNIFORM GARRISON	2	0	0	0	0	0	0
HAT, WINTER	0	0	0	0	1	0	0
HELMET, RIOT	1	0	0	0	0	0	0
HOLSTER, DETECTIVES	0	1	1	1	1	1	1
HOLSTER, DETECTIVES, PADDLE	0	1B	1B	1B	1A	1B	1B
HOLSTER, SERVICE WEAPON	1	0	0	0	0	0	0
INSIGNIA, COLLAR, HQ, POST#/ST SEAL	1	0	0	0	0	0	0
INSIGNIA, COLLAR, MSP OR RANK	1	0	0	0	0	0	0

INSIGNIA, RANK/BLOUSE OR OVERCOAT	4	0	0	0	0	0	0
JACKET, CAR-WINTER/SUBDUED PATCH	0	0	0	1	0	0	0
JACKET, CAR	1	0	0	0	0	0	0
JACKET, RAID	0	1	0H	0H	1	1	0
MAGAZINES (9MM)	2	2	2	2	2	2	2
NAME BAR	2	0	0	0	0	0	0
OVERCOAT	1	0	0	0	0	0	0
PARKA	1A	0	1E	0	1A	0	1E
PARKA WITH SUBDUED PATCHES	0	0	0	1A	0	0	0
PATCHES, FATIGUE UNIT DESIGNATION	N	N	N	Y	N	N	Y
PATCHES, SUBDUED FOR FATIGUES	N	N	N	Y	N	N	N
RAINCOAT AND GARRISON HAT COVER	1	0	0	0	1	0	0
SERVICE BARS & STARS	Y	N	N	N	N	N	N
SHIRT, DK BLUE, SHORT SLEEVES	3	0	0	0	0	0	0
SHIRT, DK BLUE, LONG SLEEVES	3	0	0	0	0	0	0
SHIRT, LONG SLEEVE FATIGUE	1	1A	1A	2	2G	1A	2
SHIRT, SHORT SLEEVE FATIGUE	0	0	0	2	2G	0	2
SHOES, UNIFORM	2	0	0	0	0	0	0
TIE BAR	2	0	0	0	0	0	0
TIE, LT. BLUE, CONVENTIONAL	3	0	0	0	0	0	0
TROUSERS, FATIGUE	1	1A	1A	2	2G	1A	2
FATIGUE SUMMER PANT	0	0	0	2	2G	0	2
TROUSERS, SUMMER	0	0	0	0	0	0	0
TROUSERS, WINTER	3	0	0	0	0	0	0
UNIT DESIGNATION PIN	0	0	0	1	0	0	0
VEST, BULLET RESISTANT	0	1A	1A	1A	1A	1A	1A
WEAPON, DETECTIVES SERVICE	0	1B	1B	2B	1B	1B	1B
WEAPON, PRIMARY	1	1	1	1	1	1	1
WEAPON, SECONDARY	1	1	1	1	1	1	1
WEAPON, SPECIAL/SEE "M"- LAST PAGE	0	1 or 2B	0	0	1 or 2B	1 or 2B	0
WHISTLE AND CHAIN	1	0	0	0	0	0	0

	DET & DET SP/TPR/SGT/ LT LAB	DET LT (14-15)	DET LT	PLAIN CLOTHES INSP & ABOVE
BADGE BY RANK	1	1	1	1
BADGE HOLDER	1	1	1	1
BELT, TROUSER	1	1A	1A	1A
BOOTS, FATIGUE	1	1A	1A	1A
CAP, FLEECE LINED, KNIT STOCKING	1	1	1	1
COVERALLS, INSULATED	1	0	1	0
COVERALLS, PLAIN	1	1	1	0
COVERALLS, SHORT SLEEVE	0	0	0	0
HANDCUFFS & KEYS	1	1	1	1
HAT, FATIGUE	1	1A	1A	1A
HAT, WINTER	0	0	0	0
HOLSTER, DETECTIVE	1	1	1	1
HOLSTER, DETECTIVE, PADDLE	1B	1B	2B	1B
INSIGNIA, COLLAR, HQ, POST#, ST SEAL	1A	1A	1A	1A
INSIGNIA, COLLAR, MSP OR RANK	1A	1A	1A	1A
JACKET, CAR	1	0	0	0
JACKET, RAID	0	0G	1	0

MAGAZINES (9MM)	2	2	2	2
PARKA	1A	1E	0	0
PATCHES, FATIGUE UNIT DESIGNATION	Y	0	0	0
PATCHES, FATIGUE LAST NAME	Y	0	0	0
RAINCOAT AND HAT	1	0	0	0
SHIRT, LONG SLEEVE FATIGUE	2	1A	1A	1A
SHIRT, SHORT SLEEVE FATIGUE	0	0	0	0
SHIRT, SUMMER FATIGUE (SHORT SLEEVE)	2	0	0	0
SHOES - UNIFORM	1	0	0	0
TROUSERS, FATIGUE	1	1A	1A	1A
FATIGUE SUMMER PANT	2	0	0	0
VEST, BULLET RESISTANT	1A	1A	1A	1A
WEAPON, DETECTIVE SERVICE	1B	1B	1B	1B
WEAPON, PRIMARY	1	1	1	1
WEAPON, SECONDARY	1	1	1	1
WEAPON, SPECIAL - ONLY ISSUED WITH SID OR FM COMMANDER WRITTEN APPROVAL	0	0	1 OR 2B	0

	CAP SEC OFC	CAP SEC SGT
BADGE BY RANK	1	1
BADGE, MOURNING BADGE RIBBON	1	1
BADGE, HAT, BY RANK	1	1
BATON, 36" RIOT	1	1
BATON CASE	1	1
BATON, COLLAPSIBLE	1	1
BELT RETAINER	5	5
BELT, SAM BROWNE	1	1
BELT, TROUSER	1	1
BLOUSE, DRESS	0	0
BOOTS, FATIGUE	1	1
CAP, FLEECE LINED, KNIT STOCKING	1	1
COVERALLS, INSULATED	0	0
COVERALLS, PLAIN	0	0
GAS CASE (CHEMICAL REPELLANT)	1	1
GLOVES, BLACK	1	1
HANDCUFF CASE	1	1
HANDCUFFS & KEYS	1	1
HAT BAND, GOLD OR SILVER	0	1
HAT, FATIGUE	1	1
HAT, UNIFORM GARRISON	2	2
HAT, WINTER	0	0
HELMET, RIOT	1	1
HOLSTER, SERVICE WEAPON	1	1
INSIGNIA, CHAPLAINS COLLAR CROSS	0	0
INSIGNIA, CHAPLAINS LAPEL CROSS	0	0
INSIGNIA, COLLAR, HQ, POST#, ST. SEAL	1	1
INSIGNIA, COLLAR, MSP OR RANK	1	1
INSIGNIA, RANK/BLOUSE/OVERCOAT	0	0
JACKET, CAR	1	1
MAGAZINES (9MM)	2	2
NAME BAR	2	2

PARKA	1A	1A	0
OVERCOAT			1
RAINCOAT AND GARRISON HAT COVER	1	1	1
SHIRT, DK BLUE, SHORT SLEEVE	0	0	1
SHIRT, DK BLUE, LONG SLEEVE	0	0	1
SHIRT, LT BLUE, SHORT SLEEVE	3	3	0
SHIRT, LT BLUE, LONG SLEEVE	3	3	0
SHIRT, SHORT SLEEVE FATIGUE	1	1	0
SHIRT, LONG SLEEVE FATIGUE	1	1	1
SHOES - UNIFORM	2	2	1
TIE BAR	2	2	2
TIE, LT BLUE, CLIP-ON	0	0	2
TIE, DK BLUE, CLIP-ON	3	3	0
TROUSERS, FATIGUE	1	1	1
FATIGUE SUMMER PANT	0	0	0
TROUSERS, SUMMER	0	0	0
TROUSERS, WINTER	3	3	1
VEST, BULLET RESISTANT	1K	1K	1
WEAPON, PRIMARY	1	1	0
WEAPON, SECONDARY	1	0	0
WHISTLE & CHAIN	1	1	1

	MC OFCR	MC INV	MC SGT	MC LT	MC INSP	CIV VEH INSP
BADGE BY RANK	1	1	1	1	1	0
BADGE, MOURNING BADGE RIBBON	1	1	1	1	1	0
BADGE, HAT, BY RANK	1	1	1	1	1	0
BATON CASE	1	1	1	1	1L	0
BATON, COLLAPSIBLE	1	1	1	1	1L	0
BELT RETAINER	5	5	5	5	5	0
BELT, SAM BROWNE	1	1	1	1	1	0
BELT, TROUSER	1	1	1	1	1	1
BLOUSE, DRESS	1	1	1	2A	2A	0
BOOTS, INSULATED	2	1	1	1	1	1
CAP, FLEECE LINED, KNIT STOCKING	1	1	1	1	1	1
COVERALLS, INSULATED	1	1	1	0	0	2
COVERALLS, PLAIN	1	1	1	1	1	3
GAS CASE (CHEMICAL REPELLANT)	1	1	1	1	1L	0
GLOVES, BLACK	1	1	1	0	0	0
HANDCUFF CASE	1	1	1	1	1	0
HANDCUFFS & KEYS	1	1	1	1	1	0
HAT BAND, GOLD OR SILVER	0	0	1	1	1	0
HAT, HARD (SKULL CAP INSERT)	1J	1J	1J	1J	1J	1J
HAT, FATIGUE	2	1	1	1	1	1DJ
HAT, UNIFORM GARRISON	1	2	2	2	2	0
HAT, WINTER	1	1	1	1	1	1
HIGH VISIBILITY VEST	1	1	1	1	1	1
HOLSTER, SERVICE WEAPON	1	1	1	1	1	0
INSIGNIA, COLLAR, HQ, POST#, ST. SEAL	1	1	1	1	1	0
INSIGNIA, COLLAR, MSP OR RANK	1	1	1	1	1	0
INSIGNIA, RANK/BLOUSE/OVERCOAT	0	0	0	2	2	0
JACKET, CAR	1	1	1	1	1	1DJ
MAGAZINES (9MM)	2	2	2	2	2	0

NAME BAR	2	2	2	2	2	0
OVERCOAT	0	0	0	0	1	0
PARKA	1A	1A	1A	1A	1A	1AD
RAINCOAT AND GARRISON HAT COVER	1	1	1	1	1	1
SERVICE BARS & STARS	Y	Y	Y	Y	Y	N
SHIRT, LT BLUE, SHORT SLEEVE	2	5	5	5	5	0
SHIRT, LT BLUE, LONG SLEEVE	2	5	5	5	5	0
SHIRT, SHORT SLEEVE FATIGUE	5	3	3	2	2	5D
SHIRT, LONG SLEEVE FATIGUE	5	3	3	2	2	5D
SHOES - UNIFORM	1	2	2	2	2	1
SHOULDER STRAP	1	1	1	1	1	1
TIE BAR	2	2	2	2	2	0
TIE, DK BLUE, CLIP-ON	2	5	3	3	3	0
TROUSERS, FATIGUE	5	3	3	2	2	3D
TROUSERS, SUMMER FATIGUE	5	3	3	2	2	3
TROUSERS, SUMMER	0	0	0	0	0	0
TROUSERS, WINTER	3	5	3	3	3	0
VEST, BULLET RESISTANT	1	1	1	1	1	0
WEAPON, PRIMARY	1	1	1	1	1	0
WEAPON, SECONDARY	1	1	1	1	1	0
WHISTLE AND CHAIN	1	1	1	1	1	0

	CIV OPER @ POL SITE	CIV LAB MBRS	CIV EMHSD MBRS	RADIO TECH	TD PERM STAFF	TD RECRUIT TEMP	TD ORD TEMP & PERM
BADGE BY RANK	0	0	0	1	0	0	0
BADGE HOLDER	0	0	0	1	0	0	0
BELT, TROUSER	1	1	1	0	0	0	0
BOOTS, FATIGUE	0	1	1	0	0	0	0
CAP, FLEECE LINED, KNIT STOCKING	0	1	0	0	0	0	0
COVERALLS, INSULATED	0	1	0	0	0	0	0
COVERALLS, PLAIN	0	0	0	1	0	0	0
HAT, HARD	0	0	0	1	0	0	0
HAT, FATIGUE	0	1	1	0	0	0	0
INSIGNIA, COLLAR, HQ, POST #, ST. SEAL	1	0	0	0	0	0	0
JACKET, CAR	0	0	0	0	0	0	0
PARKA	1A	0	0	1AC	0	0	0
PATCHES, FATIGUE UNIT DESIGNATION	0	Y	0	0	0	0	0
PATCHES, FATIGUE LAST NAME	0	Y	0	0	0	0	0
RAINCOAT AND HAT	0	0	0	0	0	0	0
SHIRT, LT BLUE, SHORT SLEEVE	3	0	0	0	0	0	0
SHIRT, LT BLUE, LONG SLEEVE	3	0	0	0	0	0	0
SHIRT, SHORT SLEEVE FATIGUE	0	0	0	0	2A	0	0
SHIRT, LONG SLEEVE FATIGUE	0	2	2	0	2A	0	0
SHIRT, SUMMER FATIGUE (SHORT SLEEVE)	0	2	2	0	0	0	0
SHOES - UNIFORM	1	0	0	0	0	0	0
TIE BAR	2	0	0	0	0	0	0
TIE, DK BLUE, CLIP-ON	2	0	0	0	0	0	0
TROUSERS, FATIGUE	0	1	1	0	3A	3A	5A
TROUSERS, SUMMER FATIGUE	0	2	2	0	0	0	0
TROUSERS, SUMMER	0	0	0	0	0	0	0
TROUSERS, WINTER	2	0	0	0	0	0	0

- A: UPON REQUEST
- B: ISSUED IN LIEU OF ANOTHER ITEM
- C: USED - INSIGNIA REMOVED
- D: ISSUED WITHOUT PATCHES
- E: REQUIRES WRITTEN APPROVAL FROM DIVISION COMMANDER
- F: ISSUED WITH CADET PATCHES
- G: ONE ADDITIONAL SET FOR MEMBERS ASSIGNED AS FIRE INVESTIGATORS
- H: ONE FOR FIELD DETECTIVES ONLY
- J: ISSUED BY CVED-HQ
- K: ONLY WITH SIGNED AGREEMENT
- L: IF QUALIFIED BY PPCT TRAINING
- M: ONLY ISSUED WITH SID COMMANDER WRITTEN APPROVAL

Section 4: Special Items Approved to Wear with the Uniform

This section lists special items that various work units have received approval to wear with a department uniform, but which are not available from the Distribution Center. Instead, these items may be issued to the member through the individual work unit. This section does not list special equipment provided by a work unit that is not part of a uniform such as dive suits and tanks, harnesses for canines, or Emergency Support Team radios and helmets.

4.1 Approved Uniform Items

- a. Fire Investigators
 - i. Boots, hip (1)
 - ii. Hard hat and liner (1)
- b. Recruiting and Selection Section
 - i. Navy blue pullover shirt with “MSP” logo (1)
 - ii. Athletic shoes (1)
 - iii. Insignis, recruiter ribbon (1)
- c. Motor Carrier
 - i. All Officers
 - 1. Hard hat (1)
 - 2. Goggles (1)
 - 3. Web gun belt and accessories (1)
 - 4. Special holster (1)
 - ii. Vehicle Safety Inspectors
 - 1. Boots, special insulated (1)
 - 2. Hard hats (1)
 - 3. Goggles (1)

d. Field Operations

i. Accident Reconstruction

1. Boots, special insulated (1)
2. Web gun belt and accessories (for use in conducting vehicle examinations only) (1)

ii. Aviation Unit

1. Flight suit (2)
2. Boots, special insulated (1)
3. Shoulder holster and harness (1)
4. Leather flight jacket (1)
5. Insignia, pilot wings (1)
6. MSP Aviation fatigue uniform hat (1)

iii. Canine Unit

1. Web gun belt with holster, magazine pouch, and handcuff case (1)
2. Class D (fatigue) uniform hat with subdued logo (1)
3. Camouflage fatigues with green shoulder patches and unit designation (1)
4. Rain gear (1)
5. Boots, special insulated (1)
6. Boots, special summer (1)

iv. Emergency Support Team (Uniform Members)

1. Class D (fatigue) uniform with subdued Emergency Support Team logo (2)
2. Black watch hat (1)
3. White camouflage (1)
4. Gortex rain jacket and pants (1)
5. ALICE "H" harness or load bearing vest (1)
6. Web gun belt with ammunition pouch, hydration back, and ballistic plate carriers (1)
7. Shooting mitten (1)
8. Low-ride holster with magazine pouch (1)
9. High-ride holster for 40 caliber weapon (1)
10. Trousers, insulated winter (1)

11. Boots, special insulated (1)
12. Athletic shoes (1)
- v. Underwater Recovery Unit
 1. Navy blue watch cap (1)
 2. Canvas shoes (1)
 3. Web gun belt and accessories (1)
- vi. Bicycle Patrol Unit
 1. Approved bicycle patrol uniform
 - a) Uniform shirts (2)
 - b) Uniform pants (1)
 2. Approved bicycle patrol jacket (1)
 3. Black bicycle or athletic shoes
- e. Training Division (1)
 - i. Polo, long or short sleeve, with "MSP" logo
 - ii. Athletic shoes (1)
 - iii. All weather jacket and pants.
- f. Community Service Troopers (CST)
 - i. Polo shirt, long sleeve, with "MSP" logo and "Community Service Trooper" written under the "MSP" logo (1)
 - ii. Polo shirt, short sleeve, with "MSP" logo and "Community Service Trooper" written under the "MSP" logo (1)
 - iii. Community Service Trooper jacket with the "MSP" logo and "Community Service Trooper" written under the "MSP" logo (1)
 - iv. Navy blue Community Service Trooper hat (1)
- g. Uniformed Enforcement Members (All)

Approved Personal Items

- i. Socks
 1. When worn with oxfords, socks shall be black or navy blue.
 2. When worn with boots, athletic or boot socks may be worn.
- ii. Gloves, black, for all uniformed enforcement members, as specified in Section 1.2.

- iii. Duplicate badges (see Section 1.5).
- iv. Personal holster other than department issue is permitted for detectives and members in administrative positions (Section 1.2).
- v. Mini flashlight and holster (e.g., Mag Light, Stinger)
- vi. Dark blue crew neck or turtleneck T-shirt for wear under the Class D (fatigue) uniform shirt.
- vii. Handcuffs, Secondary Set
 - 1. Members may carry a secondary set of handcuffs on their Sam Browne belt under the following conditions:
 - a) The handcuffs are Smith and Wesson Model 1 or Model 100 chain handcuffs, nickel in color.
 - b) They are carried in a leather handcuff case identical in finish and appearance to their issued handcuff case.
 - c) The secondary set of handcuffs and case must be purchased at the member's expense.
 - 2. Members may choose to wear two single-cuff cases or one double-cuff case on their Sam Browne belt.
 - 3. Members shall only wear one single-cuff case, one double-cuff case, or two single-cuff cases on their Sam Browne belt at one time.

Section 5: Uniforms Reference Materials

[5.1 Uniforms for Enlisted Members](#)

[5.2 Uniforms for Motor Carrier Officers](#)

[5.3 Uniforms for State Properties Security Officers](#)

Review Responsibility:	Field Operations Bureau; Field Support Bureau; Professional Development Bureau
Accreditation Standards:	CALEA