



**DEPARTMENT OF PUBLIC SAFETY  
POLICIES & PROCEDURES**



Subject: <b>Uniforms, Grooming, and Equipment</b>		Policy Number: <b>ADM: 24</b>
Revision Number: <b>17</b>	Effective Date: <b>01/20/2025</b>	Original Issue Date: <b>08/07/1992</b>

**1) PURPOSE**

a) The purpose of this policy is to ensure the Department of Public Safety commissioned and communications personnel are consistent in appearance and readily identifiable. This policy specifically authorizes certain uniform clothing, insignia, attachments, and equipment items in order to establish standards for the proper wearing of the authorized uniform. This policy is meant to promote the image of a disciplined, identifiable, and impartial law enforcement agency by maintaining the uniform as a symbol of neutral government authority, free from expressions of personal religion, bent, or bias.

**2) POLICY**

a) It is the policy of the Department of Public Safety that commissioned and communications personnel will wear only such uniforms, equipment, and insignia approved by the Department. This shall be done while maintaining a neat appearance in groom and dress.

**3) APPLICABILITY**

a) This policy is applicable to all commissioned officers and communications dispatch personnel of the Department of Public Safety.

**4) REFERENCES**

- a) CALEA Chapter 22 – Compensation, Benefits, and Conditions of Work B. CALEA Chapter 41 – Patrol
- b) ADM:37 Tattoos and Body Piercings
- c) NMAC Rule 10.5.100 Standard of Conduct

**5) DEFINITIONS**

a) **Gross Negligence** - Failure to use even the slightest amount of care in a way that shows recklessness or willful disregard for the equipment issued.



## DEPARTMENT OF PUBLIC SAFETY POLICIES & PROCEDURES



- b) **Negligence** - Failure to exercise the care that a reasonably prudent person would exercise when utilizing, caring for, or maintaining their issued equipment.
- c) Stress – a state of mental or emotional strain or tension resulting from adverse or very demanding circumstances.
- d) Volatile – tending to erupt into violence.

### 6) OPERATIONAL PROCEDURES

- a) General Requirements for Commissioned Personnel:
  - i) An authorized State Police uniform is to be worn by all commissioned personnel while on-duty in a uniform capacity, which includes regular shifts, shift extensions, overtime projects, and/or special assignments.
  - ii) On-duty personnel shall only carry authorized/approved equipment on their person that is necessary to perform their duties and which they have been trained to use.
  - iii) Uniform personnel shall always display their badge of office in plain sight.
  - iv) Leather gear, accessories, patches, and insignia are to be worn as authorized.
  - v) All leather gear, headgear, and brass will be kept polished at all times.
  - vi) Uniforms and regulation cap shall be kept clean, pressed, and mended at all times.
  - vii) All insignia, patches, nameplates, etc. shall be affixed to, and worn on, the uniform only as described in this policy. Medals shall be worn in accordance with *ADM: 28 Medals and Awards*.
  - viii) Each officer shall maintain a complete supply of uniforms and equipment.
  - ix) The uniform may not be worn in an attempt to gain favorable considerations in purchasing anything of value or to receive free admissions, gifts, or gratuities. Uniforms shall not be worn for driver's license photographs.
  - x) The uniform shall not be adorned with unauthorized insignia or decorations.
  - xi) While in uniform, the wearing of mirrored lens sunglasses, or any other eyewear of unusual design, construction, shape, or color which represents a less than professional appearance, is prohibited.



## DEPARTMENT OF PUBLIC SAFETY POLICIES & PROCEDURES



- xii) The uniform is not to be altered in any way other than authorized in policy. Proper fit is to be maintained, and tailoring done in a conservative fashion.
- xiii) No personnel shall wear the uniform or use any state equipment while under suspension for any cause. Suspended personnel shall immediately surrender their badge, gun, commission, and all other state-owned property to the district/bureau commander when the suspension is imposed.
- xiv) Officers traveling inter-district in a marked unit are to be in full uniform unless otherwise approved by the Chief or his/her designee. Officers on special assignments may utilize their units while off duty, as specified in 10.5.400 NMAC.
- xv) Officers operating marked units within their assigned district shall be in the appropriate uniform attire, unless exempted by the district commander or his/her designee.
- xvi) All uniform and CVE bureau personnel assigned a Department issued electronic control device, regardless of rank, are required to carry the ECD at all times while on-duty when in class "A" or BDU uniform. Plainclothes personnel assigned an ECD, regardless of rank, are required to carry the ECD when participating in high risk or pre-planned operations.

### **b) Class "A" Uniform for Commissioned Officers**

The Class "A" shirt, trousers, and cap will only be obtained from the State Police Quartermaster or from a retail outlet authorized by the Department of Public Safety.

- i) **Shirt:** The NMSP shirt will be black in color with gray cuffs, epaulets, and breast pocket flaps. Single or double (French) shirt cuffs are permissible.
  - (1) The long-sleeve shirt may be worn year-round.
  - (2) The short-sleeve summer shirt may be worn between March 1 and November 30. The short-sleeve length will not be shorter than a point two (2) inches above the elbow, down, and the sleeve will have a hem of one (1) inch.
- ii) **Bowtie:** The plain black regulation bowtie will be optional when the long-sleeve shirt is worn. The Chief or his/her designee may require that the bowtie be worn for special occasions.



## DEPARTMENT OF PUBLIC SAFETY POLICIES & PROCEDURES



- iii) **Undershirt:** When the bowtie is not worn, the undershirt shall not be visible, unless the undershirt is black in color.
- (1) During winter months, a black mock turtleneck undershirt may be worn with “NMSP” embroidered in either silver or gold on the front left side of the neck. Silver lettering shall be used for officers with less than five (5) years of service and gold for those with five (5) years of service or more. The embroidery will be block lettering and standard in height at  $\frac{1}{2}$  inch. It should be located approximately  $\frac{3}{4}$  of an inch below the top of the collar, and to the left of the center of the neck.
  - (2) Due to design changes in the neck line of protective vests, it is appropriate to wear a black crew neck t-shirt under all authorized uniforms. The black t-shirt shall be made of moisture wicking material as found in apparel provided by manufacturers, such as Under Armour; 511; Blauer; and Champion. Logos shall not be visible on the collar area.
  - (3) The V-neck t-shirt is still authorized and does not need to be color specific, as long as it is not visible above the neck line.
- iv) **Patches, Buttons, Service Stripes, and Insignia:** All patches and insignia will be worn on the regulation uniform shirt for all bureaus.
- (1) NMSP Patrolmen with less than five (5) years of service will have “NM-SP” collar insignia with the lettering in silver as well as silver uniform buttons.
  - (2) NMSP Patrolmen with five (5) years of service or more will have “NM-SP” collar insignia with the lettering in gold along with gold uniform buttons.
  - (3) Service stripes will only be worn for years of service in DPS. Any prior law enforcement service will not be counted in determining the number of years served. Service stripes will be worn centered on the lower left arm of the long sleeve uniform, sewn  $1 \frac{1}{2}$  inches above the cuff. One (1) stripe will be worn for each completed year of service up to four (4) years. One (1) gold star on a stripe will be worn for each five (5) years of completed service. NMSP Service stripes will be gray.
  - (4) The “Instructor” patch may be worn centered on the lower right arm of the long sleeve uniform, also sewn  $1 \frac{1}{2}$  inches above the cuff.
  - (5) Various specialty team patches may be worn and shall be affixed on the right sleeve above the “Instructor” patch and centered on the sleeve.



## DEPARTMENT OF PUBLIC SAFETY POLICIES & PROCEDURES



- v) **Badge of Office and Name Plate:** The badge of office will be worn above the left breast pocket. A name plate will be worn centered above the right breast pocket. The name plate will be worn 1/8 inch above the top edge of the pocket. At a minimum the name plate will have the first initial and last name of the officer. Name plates with first names, rank, and “serving since” information may also be worn.
- vi) **Trousers:** Only regulation issue trousers will be worn. The trousers will be black in color with a gray stripe. The stripes will be on the outside of both legs running the length of the pants. The bottom of the trouser legs shall hang between 1 ½ inches and 2 ½ inches from the floor when standing with footwear on. The wearing of summer or winter trousers will be optional year round.
- vii) **Cap:** Regulation cap will be made of the same material as the trousers. The regulation cap has eight (8) points. The regulation “Droop” visor is 1 7/8 inches wide. The cap (shield, band, braid, visor, and material) shall be kept clean at all times. The cap will be worn at all times, while in uniform outside of buildings and cars, straight on the head, with the visor two (2) finger width above the bridge of the nose. The summer or winter style cap may be worn year round. Exceptions to Officers not wearing their covers(cap) during high stress or volatile situations are as follows: vehicle pursuit where the officer has to quickly exit his/her unit for a felony stop and/or foot pursuit to apprehend and gain compliance from alleged suspect(s), use of force where an officer is in a physical altercation with a suspect and cap falls off, and when an officer has to immediately react and exit his/her unit to a high risk traffic stop or emergency incident as either a primary or back up Officer. Once Officer(s) have control of the scene, they shall retrieve their cap and place back on their head.
- (1) All officers with less than five (5) years of service shall wear caps with silver braid and silver metal front band. All officers wearing the uniform with five (5) or more years of service shall wear caps with gold braid and gold metal front band. The gold or silver front band shall, in every case, be worn centered, covering the lower gold or silver braid.
- (2) The *formal* caps for the Chief and Deputy Chiefs shall have an embroidered or metal oval gold wreath with the rank spelled out in gold, centered on the front of the cap. The visor shall contain two (2) double rows of gold oak leaves. Only the Chief’s cap shall have a single row of gold oak leaves around the sides and back of the cap.



## DEPARTMENT OF PUBLIC SAFETY POLICIES & PROCEDURES



- (3) The *informal* caps for the Chief and Deputy Chiefs shall have the regulation metal cap shield and the visor shall contain two (2) double rows of oak leaves. The cap shield will have the rank spelled out above, and the words "STATE POLICE" below the Great Seal of the State.
- (4) The caps for Majors and Captains shall have the regulation metal cap shield and will have two (2) single rows of gold oak leaves on the visor. The cap shield will have the rank spelled out above, and the words "STATE POLICE" below the Great Seal of the State.
- (5) The ranking officers listed above may wear the regulation service cap without oak leaves, while working in the field.
- (6) The caps for Lieutenants and Sergeants shall have the regulation metal cap shield and will not have oak leaves. The cap shield will have the rank spelled out above and the words "STATE POLICE" below the Great Seal of the State.
- (7) The caps for senior and junior patrolmen shall have the regulation metal cap shield and will not have oak leaves. The cap shield will have the words "STATE POLICE" below the Great Seal of the State.
- viii) **Footwear:** A plain toe, black, smooth grain, leather shoe or plain toe, black, smooth grain leather boot is required. If low-cut shoes are worn, plain black socks are required.
- ix) **Belt:** Black leather Sam Browne with "suicide strap," with regulation brass buckle on belt and strap. Sidearm holster and equipment carriers will be attached to the Sam Browne. The style will be basket-weave, flower carved, or other conservative pattern.

### c) Commercial Vehicle Enforcement Uniform

- i) Commissioned CVE employees will wear the authorized BDU uniform when engaged in normal day-to-day operations. See section "D" for approved BDU uniform for commissioned personnel.
- ii) Non-commissioned Transportation Inspectors will wear the following uniform:
  - (1) Dark blue BDU tactical pants.
  - (2) Long-sleeve, dark blue BDU shirt with badge and cloth name tag (gray letters on black background). TI shoulder patches will be worn on each sleeve. Other patches or insignia may be worn with the Chief's approval. Between March 1 and November 30 a short-sleeve dark blue BDU shirt may be worn.



## DEPARTMENT OF PUBLIC SAFETY POLICIES & PROCEDURES



- (3) The “Transportation Inspector” breast shield is only for official use **ON-DUTY** and will be worn in the proper location on the uniform shirt. The proper location on the uniform shirt is above the left breast pocket. Under no circumstance is the shield to be carried or displayed **OFF-DUTY** for any reason or purpose, nor will the inspector represent themselves as a commissioned officer.
- (4) A long-sleeve dark blue polo shirt may be worn year round. A short-sleeve dark blue polo shirt may be worn between March 1 and November 30. The shirt must have a cloth badge imprinted or embroidered on the left side and the transportation officer’s name embroidered on the right side. The color of the letters will be silver.
- (5) Footwear will be black leather, plain toe, laced approved combat style boots, or combination black leather/cordovan or canvas.
- (6) The cap to be worn with the fatigue uniform will consist of a dark blue, baseball style cap, with a badge attached or imprinted on its front, or any other style authorized by the Chief or his/her designee for a specific use. The cap will be worn at all times, no exceptions, while in uniform outside of buildings and cars.
- (7) During inclement weather a conservative dark blue knit cap can be worn. The cap should have no visible logos. A badge or shoulder patch may be affixed to the front of the cap optionally.
- (8) The jacket or coat to be worn with the fatigue uniform or coverall will be any authorized outer garment.

**d) Commissioned Personnel “BDU” Uniform – for special assignments as ordered.**

The BDU uniform for commissioned officers may be worn when authorized by the district/bureau commander or higher ranking officer with their agency appropriate patches. The fatigue uniform shall consist of the following:

- i) Black BDU tactical pants.
- ii) Long-sleeve, black BDU shirt with badge and cloth name tag (gray letters on black background) may be worn year round. Shoulder patches will be worn on each sleeve. Insignia of rank is displayed on the shirt collar for Lieutenants and above, and on the sleeve for Sergeants. Other patches or insignia may be worn with the Chief’s approval. For further information on Specialty Team uniforms refer to Section G.



## DEPARTMENT OF PUBLIC SAFETY POLICIES & PROCEDURES



- iii) A long-sleeve black polo shirt may be worn year round. A short-sleeve black polo shirt may be worn between **March 1 and November 30**. The shirt must have a cloth badge imprinted or embroidered on the left side and the officer's name embroidered on the right side. The color of the letters will be gold.
  - iv) Between **March 1 and November 30** the summer uniform the shirt may consist of a crew neck black T-shirt or black short-sleeve BDU shirt with badge and cloth name tag (gray letters on black background). The T-shirt will have a cloth badge imprinted on the left side and the officer's name embroidered in, or a cloth name tag on, the right side. The color of the letters will be gold.
  - v) Footwear will be black leather, plain toe, laced approved combat style boots, or combination black leather/cordovan or canvas.
  - vi) The Sam Browne belt shall be worn without the shoulder strap. Nylon web gear or a staff holster with a cartridge holder may also be worn, when appropriate.
  - vii) The cap to be worn with the fatigue uniform will consist of a black, baseball-style cap, with a badge attached or imprinted on its front, or any other style authorized by the Chief or his/her designee for a specific use. The cap will be worn at all times, no exceptions, while in uniform outside of buildings and cars.
  - viii) During inclement weather a conservative black knit cap can be worn. The cap should have no visible logos. A badge or shoulder patch may be affixed to the front of the cap optionally.
  - ix) The jacket or coat to be worn with the fatigue uniform or coverall will be any authorized outer garment.
- e) **State Police Staff Uniform:** All field officers with the rank of Lieutenant and above may, and all headquarters staff officers (regardless of rank) shall, wear the regulation staff uniform, unless exception is made by the Chief.
- i) **Shirt:** Light gray perma-press material with one (1) button cuffs and regular dress shirt collar.
    - (1) Short-sleeves are optional during the period of March 1 to November 30.
    - (2) Only the following may be worn on the staff shirt: Staff badge, two (2) miniature metal rank insignia worn on collar for all ranks, nameplate,





## DEPARTMENT OF PUBLIC SAFETY POLICIES & PROCEDURES



approved pins, two (2) shoulder patches, and other appropriate insignia authorized by the Chief.

- ii) **Trousers/Cap/Footwear:** As specified in Section B.
  - iii) **Tie:** Plain black tie between two (2) inches to three (3) inches at its widest point.
  - iv) **Belt:** Black leather, less than two (2) inches wide with regulation brass, nickel or chrome buckle, snap or Velcro closure.
  - v) **Holster and Cartridge/Magazine case:** Black leather basket-weave, flower carved, or other conservative pattern.
- f) **Inclement weather uniform:** Black, insulated coveralls may be worn when working outdoors in extremely adverse weather conditions. The coveralls shall have shoulder patches and a cloth or metal badge attached as well as insignia of rank, when applicable. Insignia will consist of cloth chevrons on the sleeves, for Sergeants, and cloth or metal insignia on the collar for those above the rank of Sergeant. The cap to be worn with the coveralls will be the fatigue cap, hood, black fur cap, or other conservative plain black knit cap.
- g) **Jackets:** The following jackets are authorized to be worn:
- i) A leather jacket in a style authorized by the Chief or his/her designee may be worn with the Class "A" or BDU uniform.
    - (1) Large shoulder patches shall be displayed on the sleeves along with a metal badge on the front, left side. The rank for Sergeants will be displayed by chevrons on the sleeves or metal insignia on the collar. The rank insignia for Lieutenants and above shall consist of metal insignia displayed on the shoulder epaulets.
    - (2) There will be no modification to the jacket.
  - ii) Only raincoats that are department issued may be worn by uniform personnel.
  - iii) Any other non-issue jackets worn by uniform personnel shall be black in color with a badge and shoulder patches affixed to it. Rank insignia will be worn on the jacket in the appropriate manner listed above. These jackets must be approved by the district commander or his/her designee.
  - iv) The state police staff coat shall be regular dress coat length, single breasted, two (2) or three (3) button front, two (2) button sleeves, two (2) lower patch pockets and no chest pocket. It shall have double vent,



## DEPARTMENT OF PUBLIC SAFETY POLICIES & PROCEDURES



- badge carrier, and epaulets. Only the following will be worn on the staff coat:
- (1) Badge (metal), rank, “NM-SP” lapel insignia, shoulder patches, other appropriate insignia authorized by the Chief.
  - (2) The sleeve stripes will be oxford gray. The staff coat will be worn as follows:
    - (a) Chief – four (4) stripes on each sleeve.
    - (b) Deputy Chiefs – three (3) stripes on each sleeve.
    - (c) Majors – one (1) stripe on each sleeve.
  - (3) The sleeve stripes will be  $\frac{3}{4}$  inch in width, and when more than one (1) stripe is worn, the width between each strip will be  $\frac{3}{4}$  inch.
- v) The regulation “Ike” jacket may be worn on formal occasions with white dress shirt, black cravat tie, and Sam Browne belt without shoulder strap, at the Chief’s discretion. It shall also be optional to wear the jacket with the regulation shirt. When worn, the Ike jacket shall be fully buttoned and zipped at all times. Only the following shall be worn on the Ike jacket:
- (1) Badge (metal)
  - (2) Rank
  - (3) Nameplate
  - (4) Shooting badge
  - (5) Shoulder patches
  - (6) Whistle and cord (optional)
  - (7) Other insignia authorized by the Chief.
- h) **Specialty Teams:** Specific uniforms may be worn by specialty teams as determined by the team commander for assignment/mission. During special assignments or community events, each specialty team commander shall ensure that all team members are wearing the same color uniform or alternate uniform as directed by the Special Operations Commander.
- i) **State Police Tactical Team:**
- (1) The Nomex flight suit may be worn in olive drab green.
  - (2) BDU tactical pants may be worn in olive drab green, Multicam, woodland camouflage, black, tan, or any current military pattern best suited for concealing the team member from threats depending on the specificity of the mission.
  - (3) BDU tactical shirt can be worn in olive drab green, woodland camouflage, black, tan, or any current military pattern best suited for



## DEPARTMENT OF PUBLIC SAFETY POLICIES & PROCEDURES



concealing the team member from threats depending on the specificity of the mission.

- (4) The polo shirt will be worn in one of three (3) colors; olive drab green, black, or tan.
- (5) The T-shirt will be worn in one of three (3) colors; olive drab green, black, or tan.
- (6) The baseball cap will be worn in one of three (3) colors; olive drab green, black, or tan. The State Police Tactical Team insignia will be embroidered on the front of the cap and optionally the team member's name on the rear of the cap. No flat brimmed hats or hats with stickers should be worn.
- (7) The boonie cap can be worn in one of many colors to include; olive drab green, woodland camouflage, black, tan, or any current military pattern best suited for concealing the team member from threats, depending on the specificity of the mission.
- (8) The New Mexico State Police Tactical Team jacket will be worn in one of two (2) colors; olive drab green or black.
- (9) Boots can be worn in one of many colors to include; olive drab green, woodland camouflage, black, tan, or any current military pattern best suited for concealing the team member from threats, depending on the specificity of the mission.
- (10) The color of all insignias (American Flags, specialty patches, etc.) and name tags will be consistent with the color of the shirt worn.
- (11) A patch or insignia representing the rank of the team member will not be displayed on any tactical team BDU uniforms or jackets.
- (12) The team commander will have the discretion to authorize changes to the uniform with the permission of the Chief.

### **ii) Crime Scene Team:**

- (1) BDU tactical pants may be worn in three (3) colors; black, tan, or gray or olive drab green.
- (2) A BDU tactical shirt may be worn in three (3) colors; black, tan, or gray. Both short and long-sleeve BDU tactical shirts may be worn.
- (3) The polo shirt may be worn in white, black, tan, or gray.
- (4) Mock turtleneck undershirts may be worn in white, black, tan, or gray.
- (5) The baseball cap will be worn in one of two (2) colors; black or tan. The State Police Crime Scene Team insignia will be embroidered on the



## DEPARTMENT OF PUBLIC SAFETY POLICIES & PROCEDURES



front of the cap and optionally the team member's name on the rear of the cap.

- (6) The boonie cap may be worn in one of two (2) colors; black or tan.
- (7) Gray or black coveralls may be worn during crime scene processing to protect agent's clothing from contamination.
- (8) Inclement weather gear (coveralls, balaclava, etc.) may be worn during crime scene processing in extreme weather conditions.
- (9) Footwear can be worn in brown, black, or tan.
- (10) The team commander will have the discretion to authorize changes to the uniform with the permission of the Chief.

### **iii) Search and Recovery Team (Dive Team):**

- (1) BDU tactical pants will be worn in the color of black, tan or olive drab green.
- (2) BDU or moisture wicking style shorts may be worn in the color of black.
- (3) Polo shirt may be long or short sleeve with Dive Team insignias in the color of tan.
- (4) T-shirt may be long or short sleeve with Dive Team insignias in the color of tan.
- (5) Black or tan baseball-style cap with either the State Police Dive Team insignia embroidered on the front or a State Police badge may be worn.
- (6) A tan boonie cap may be worn.
- (7) Tan coveralls or black dry suit woolies may be worn during missions or training.
- (8) Footwear will be black or tan in color. Black tennis style or water shoes may be worn during training, missions, or boat patrol operations.
- (9) Dive Team members will also wear the "Search and Recovery" team patch on their lower right arm while in long-sleeve Class "A" uniform per OPR: 21 State Police Search and Recovery Team.
- (10) During boat patrol operations, black BDU style shorts and the tan polo shirts will be worn.
- (11) The team commander will have the discretion to authorize changes to the uniform with the permission of the Chief.

### **iv) Explosive Ordinance Disposal (EOD) Team:**

- (1) The Nomex flight suit may be worn in olive drab green.



## DEPARTMENT OF PUBLIC SAFETY POLICIES & PROCEDURES



- (2) BDU tactical pants may be worn in olive drab green, Multicam, black, tan or any current military pattern best suited for the specificity of the mission, either EOD or Tactical Team related.
  - (3) BDU tactical shirt can be worn in olive drab green, Multicam, black, tan or any current military pattern best suited for the specificity of the mission, either EOD or Tactical Team related.
  - (4) The polo shirt or tactical button up shirt will be worn in one of three (3) colors; olive drab green, black, or tan.
  - (5) The T-Shirt will be worn in one of three (3) colors; olive drab green, black, or tan.
  - (6) The baseball cap can be worn in one of four (4) colors; olive drab green, Multicam, black, or tan. The State Police Bomb Squad insignia will be embroidered on the front of the cap and optionally the squad member's name on the rear of the cap.
  - (7) The boonie cap can be worn in one of the many colors to include: olive drab green, Multicam, black, tan, or any current military pattern best suited for the specificity of the mission, either EOD or Tactical Team related.
  - (8) The New Mexico State Police Bomb Squad Jacket will be worn in one of two (2) colors; olive drab green or black.
  - (9) Boots can be worn in one of the many colors to include: olive drab green, Multicam, black, tan, or any current military pattern best suited for the specificity of the mission, either EOD or Tactical Team related.
  - (10) The color of all insignias (American Flags, specialty patches, etc.) and name tags will be consistent with the color of the shirt worn.
  - (11) A patch or insignia representing the rank of the squad member will not be displayed on any tactical BDU uniform or jackets.
  - (12) The Bomb Squad Commander will have the discretion to authorize the changes to the uniform with the permission of the Chief.
- v) Criminal Enforcement Unit (K-9):**
- (1) Black, tan or olive drab green BDU tactical pants.
  - (2) Black or tan long-sleeve military style BDU shirt. A short-sleeved BDU shirt may also be worn from March 1 through November 30.
  - (3) Long-sleeve or short-sleeve black polo shirts may be worn.
  - (4) Black T-Shirt with approved cloth badge.



## DEPARTMENT OF PUBLIC SAFETY POLICIES & PROCEDURES



- (5) Black baseball-style cap with either the State Police Criminal Enforcement Unit insignia embroidered on the front or a State Police badge. No flat brimmed hat or hats with stickers should be worn.
- (6) Nylon web gear.
- (7) The handler may be allowed to wear civilian clothes, in appropriate situations, if approved by the team commander or his/her designee.
- (8) The team commander will have the discretion to authorize changes to the uniform with the permission of the Chief.

### **vi) Motors Team:**

- (1) The Class "A" uniform shirt with a Motor Team patch on the lower right arm when wearing the long-sleeve shirt.
- (2) The trousers will be the same color scheme and material as the Class "A" trousers, but will be the "Motor Pant" design.
- (3) A black baseball-style cap with either the State Police Motor Team insignia embroidered on the front or a State Police badge may be worn when BDU uniforms are authorized. No flat brimmed hat or hats with stickers should be worn.
- (4) The white over black motorcycle helmet will be worn at all times during operation of a Motor Team unit.
- (5) A plain toe, black, smooth grain leather boot in the "Motor Boot" style will be worn.
- (6) The team commander will have the discretion to authorize changes to the uniform with the permission of the Chief.

### **vii) Aircraft Section:**

- (1) The Nomex flight suit will be worn in black, tan, or olive drab green.
- (2) A black baseball-style cap with either the Aviation Section insignia embroidered on the front or a State Police badge.
- (3) Pilots are authorized to wear a black waist length jacket, with a covered zipper front, side sleeve, pen pockets, and shoulder epaulets. Only the following shall be worn on the pilot's jacket: Badge (metal or cloth), shoulder patches, rank (Lieutenants and up on epaulets, Sergeants on sleeves), leather name tag with State Police pilots insignia (wings), pilot's name, and "State Police" embossed thereon, attached to right breast.
- (4) Footwear will be black leather, plain toe, laced approved combat style boots, or combination black leather/cordovan or canvas.



## DEPARTMENT OF PUBLIC SAFETY POLICIES & PROCEDURES



- (5) The department issued sidearm will be carried in a black shoulder holster.
- (6) The team commander will have the discretion to authorize changes to the uniform with the permission of the Chief.

### **viii) Honor Guard:**

- (1) The Class "A" uniform will be worn with the long-sleeve shirt and the following additions:
    - (a) White ascot style scarf around neck.
    - (b) White dress gloves.
    - (c) White braid worn around left shoulder.
  - (2) The team commander will have the discretion to authorize changes to the uniform with the permission of the Chief.
- i) **Training and Recruiting Bureau:** personnel assigned to the training and recruiting bureau may wear specific uniforms as authorized by the Training and Recruiting Bureau Commander.
- i) Training Officers:
    - (1) BDU style pant in the color of black.
    - (2) Black or Gray, long or short sleeve, polo shirt per assignment of the day.
  - ii) All certified range masters may also wear the gray polo style shirt and black BDU pants while performing range master duties only.
  - iii) Pistol Team uniforms shall be designated by the Commander of the Training and Recruiting Bureau. The pistol team patch may be worn on the Class "A" and shall be affixed on the right sleeve above the "Instructor" patch and centered on the sleeve.
- j) Personnel authorized to wear civilian clothing are the Chief and his staff, Investigations Bureau personnel, Governor's Security personnel, and Standards Bureau personnel. Exceptions for other personnel may be granted by the Chief. The style of civilian clothing worn while on duty will reflect the task(s) undertaken.
- k) Personnel in the Investigations Bureau are authorized to wear a quasi-uniform at the discretion of Investigations Bureau supervisors. These uniforms are only to be worn for certain assignments such as call-outs, raids/warrant service, IMPACT operations, etc. Quasi-uniforms may include,



## DEPARTMENT OF PUBLIC SAFETY POLICIES & PROCEDURES



but are not limited to polo shirts, long-sleeve shirts, and baseball caps. No flat brimmed hat or hats with stickers should be worn.

- l) A black wool V-neck sweater is authorized, October through April, with the State Police Class “A” and staff uniform, and must be worn over the shirt and tucked into the trousers. The badge, nameplate, and other insignia approved by the Chief, will be appropriately displayed on the v-neck sweater. Rank will not be displayed on the v-neck sweater.
- m) The only state police head cover that may be worn with the Class “A” or staff uniform and appropriate coat is the regulation cap, hood, or fur cap, depending on weather conditions.
- n) Appropriate state police rank insignia will be worn in the proper manner whenever officers are in the Class “A” uniform or Staff Uniform.
  - i) **Chief** - Four (4) gold stars on epaulet of Class “A” uniform and collar of Staff Uniform.
  - ii) **Deputy Chief** - Three (3) gold stars on epaulet of Class “A” uniform and collar of Staff Uniform.
  - iii) **Major** - One (1) gold oak leaf on epaulet of Class “A” uniform and collar of Staff Uniform.
  - iv) **Captain** - Double gold bar on epaulet of Class “A” uniform and collar of Staff Uniform.
  - v) **Lieutenant** - Single gold bar on epaulet of Class “A” uniform and collar of Staff Uniform.
  - vi) **Sergeant** - Black and gray chevrons for NMSA and red and gray chevrons for MTP on sleeves of Class “A” uniform and gold metal chevrons on collar of Staff Uniform.
- vii) Rank Positioning**
  - (1) Rank Insignia Positioning: All insignia worn on the epaulet of the Class “A” uniform shall be centered on the “X” stitching on the outer section. Specific ranks will be worn as follows:
    - (a) The multiple star insignia worn for the rank of Deputy Chief and above shall be worn running lengthwise along the shoulder and epaulet of the uniform.
    - (b) The oak leaf insignia for Majors shall be worn with the bottom facing the outside of the shoulder and the top towards the collar.





## DEPARTMENT OF PUBLIC SAFETY POLICIES & PROCEDURES



- (c) Gold bars for the ranks of Lieutenant and Captain will be placed running from front to back.
- (2) Refer to “Attachment A: Uniform Pictures” for further details on rank insignia and positioning.
- o) **Pins:** Certain pins may be worn on the State Police Class “A” uniform for those personnel that meet the criteria for that particular pin. The following is a list of pins authorized to be worn by qualified officers. For further information on specific requirements refer to the appropriate specialty team policy. The Chief or his/her designee may authorize additional pins at his/her discretion.
- i) **Tactical Team** - State Police badge with crossed lightning bolts behind it.
  - ii) **Search and Recovery Team** - Modeled on the Navy “Scuba Diver” pin, which consists of a white and gold diving helmet with a New Mexico Zia and tridents around it.
  - iii) **Explosive Ordinance Disposal Team** - Wreath around a shield, bomb, and lightning bolts in front of it. Silver for Bomb Technician, Two-tone for Senior Bomb Technician, and Gold for Master Bomb Technician.
  - iv) **Criminal Enforcement Unit** - Letters “K-9” with a wreath around them.
  - v) **Honor Guard** - State Police or MTP badge with crossed rifles behind it and a wreath around them.
  - vi) **Motors Team** - Eagle with NMSP or MTP Motor Team inscribed on it.
  - vii) **Aviation Section** - State Police badge and wings coming from both sides.
  - viii) **Governor’s Detail** - State Police badge and ribbons coming from both sides. Once the agent reached 2 years on the detail, the pin may be worn on his/her Class “A” uniform for the remainder of his/her career.
- p) **Wearing of the Pins for Commissioned Personnel** – Will wear pins only in the following manner:
- i) All pins and ribbons will be worn centered and directly above the officer’s name plate. The lowest portion of the pin will be 1/8 inch above the top edge of the name plate.
  - ii) If an officer chooses to wear a marksmanship pin in conjunction with any specialty team pin, the marksmanship pin will be centered and 1/8 inch above the name plate. The team pin will be 1/8 inch above the marksmanship pin and centered.



## DEPARTMENT OF PUBLIC SAFETY POLICIES & PROCEDURES



- iii) If an officer chooses to wear an award ribbon or military service ribbon, it will be centered and worn 1/8 inch directly above the name plate. See ADM: 28 Medals and Awards for further information on award ribbons. Any other pins will be worn centered and 1/8 inch above the award ribbon.
- iv) When multiple ribbons are worn, they will be directly above the name plate and worn side by side and centered on the name plate. Other pins will be worn in the same order as stated above 1/8 inch above the ribbons.
- v) When multiple pins are worn the order from bottom to top will always be award ribbon (if eligible), marksmanship pin, and specialty team pin.
- vi) No more than two (2) pins and two (2) award ribbons will be worn on the uniform at any one time. If an officer is eligible to wear more than one (1) specialty team pin (e.g. Honor Guard and Dive Team) only one (1) team pin may be worn on the uniform at a time.
- vii) The following diagrams are the proper procedures for the wearing of pins:

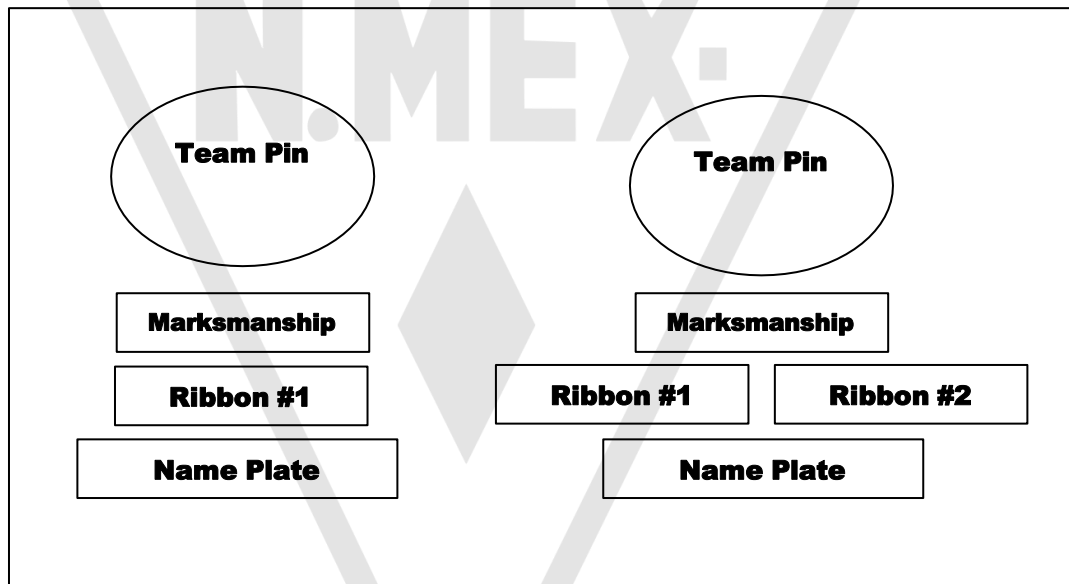

### q) Grooming Standards

- i) Male commissioned officers and transportation inspectors
  - (1) Hair
    - (a) Shall be neat, clean, trimmed, and present a groomed appearance.
    - (b) Shall not interfere with the proper wearing of the uniform cap or helmet.



## DEPARTMENT OF PUBLIC SAFETY POLICIES & PROCEDURES



- (c) Shall not touch the top of the shirt collar at any time.
  - (d) Shall not cover any part of the outside portion of the ear at any time nor will the sides bulk at or extend over the ear. The front is combed to the side or back and will not protrude below the headband of the cap.
  - (e) Color or style shall not be unusual or bizarre nor will it be dyed or streaked an abnormal color.
  - (f) The maximum extension from the scalp shall not exceed two (2) inches.
  - (g) No extreme or abnormal hair styles within these guidelines will be permitted. Team Pin Ribbon #1 Ribbon #2 Marksmanship Pin Name Plate Team Pin Marksmanship Pin Ribbon #1 Name Plate
  - (h) The wearing of a wig or hairpiece by male personnel while in uniform or on duty is prohibited except to cover or to accommodate a medical condition or physical disfigurement. When worn, it will conform to the standard haircut criteria listed above.
  - (i) Officers assigned to undercover work, where unusual hairstyles or appearances are necessary to accomplish a specific mission, are exempt from this policy. However, hair will be worn in a neat, clean, and groomed manner when at headquarters, court, participating in or instructing a class. Agents stationed at headquarters are exempt, while carrying out their normal duties.
  - (j) Plain clothes officers must follow this policy when working a temporary uniform assignment. However, individuals wearing the BDU uniform for one day operations such as qualifications, raids, training and etc. are exempt from this policy.
  - (k) Agents assigned to Crime Suppression (Street Crimes, Auto Theft, Fugitive Apprehension Unit, Violent Gangs Task Force, Joint Terrorism Task Force), will adhere to this section of the policy in relation to the grooming of their hair.
- (2) Sideburns and Facial Hair
- (a) Employees will be “clean-shaven” while on-duty. For the purpose of this policy “clean-shaven” means the removal of hair, which if allowed to grow, would constitute a beard, goatee, or moustache. This includes stubble or a five o’clock shadow. The district captain



## DEPARTMENT OF PUBLIC SAFETY POLICIES & PROCEDURES



or zone commander will have the final say on the appropriateness of overall appearance.

- (b) Employees will ensure their sideburns do not extend below the bottom of the lowest part of the exterior ear opening or tragus and will end with a clean shaven horizontal line. The maximum width at the bottom of the sideburns shall not exceed one (1) inch.
  - (c) Undercover certified employees may maintain their appearance as needed in the performance of their job duties. For example, an undercover certified agent working a narcotics undercover operation. For definition of “undercover certified” see Narcotics policies/directives.
  - (d) Agents assigned to Crime Suppression (Street Crimes, Auto Theft, Fugitive Apprehension Unit, Violent Gangs Task Force, Joint Terrorism Task Force) and Special Investigations Unit will be permitted to grow, and maintain facial hair as required by their duties.
  - (e) Criminal agents, Crime Scene agents, uniformed officers assigned to Crime Suppression Bureau and members of the Canine Handlers Unit are not permitted to grow facial hair.
  - (f) The ranks of Lieutenant and above shall not grow facial hair.
- (3) Grooming Standards for facial hair
- (a) Mustaches will be neatly trimmed and shall not extend over the lips nor extend more than 1/4 inch upward, downward, or to the side from the corner of the mouth.
  - (b) Beards, whether full or goatees, are authorized.
  - (c) Soul patches are not permitted.
  - (d) Beards shall be well groomed and neatly trimmed at all times in order not to present a ragged appearance.
  - (e) Patchy or spotty clumps of facial hair, excluding those resulting from scars, are not considered beards and as such are not permitted.
  - (f) Ungroomed beard stubble will not be considered neat, clean, and professional.
  - (g) Facial hair will not be worn in any extreme or unconventional styles.
  - (h) No portion of the beard may be exceptionally longer than the rest.
  - (i) The neck shall be kept clean shaven.



## DEPARTMENT OF PUBLIC SAFETY POLICIES & PROCEDURES



- (j) Officers that are issued gas masks must, in the event of an anticipated operational need for use of a gas mask, may be ordered to remove their beard immediately and must have the necessary equipment at work to do so in a timely manner.
  - (k) An employee's facial hair shall be trimmed or shaved so as not to interfere with the proper seal of the Department-issued respirator.
  - (l) Mustaches, beards, or goatees will not be authorized while wearing the Class A Uniform.
- (4) Fingernails
- (a) Shall be clean and trimmed while in uniform.
  - (b) Shall not extend beyond the tips of the fingers while in uniform.
  - (c) Fingernails will not be polished while in uniform.
  - (d) When working in an undercover capacity, fingernails may be worn as needed in the performance of job duties. However, fingernails will conform to this policy when at headquarters, court, participating in or instructing a class. Agents stationed at headquarters are exempt, while carrying out their normal duties.
- (5) Jewelry
- (a) Only two (2) conservative rings may be worn while in uniform.
  - (b) Necklaces will not be worn in view, while in uniform. Religious medals may be worn, provided that they are not visible.
  - (c) Earrings or piercings of any kind will not be worn.
  - (d) When working in an undercover capacity earrings and/or piercings may be worn as needed in the performance of job duties. However, all earrings and piercings will be removed when at headquarters, court, participating in or instructing a class. Agents stationed at headquarters are exempt, while carrying out their normal duties.
  - (e) For further information on piercings refer to *ADM: 37 Tattoos and Body Piercings*.
- ii) Female commissioned officers and transportation inspectors
- (1) Hair
- (a) Shall be secured and prevented from hanging down at all times when in uniform.
  - (b) Shall be neat, clean, trimmed, and present a groomed appearance.
  - (c) Styles shall not interfere with the wearing of the uniform cap or helmet.
  - (d) Shall not touch the top of the uniform shirt collar at anytime.



## DEPARTMENT OF PUBLIC SAFETY POLICIES & PROCEDURES



- (e) Shall not cover any part of the outside portion of the ear at anytime.
  - (f) The hair in front will be groomed so that it does not fall below the eyebrows and will not protrude below the band when the uniform cap or helmet is worn.
  - (g) Color and style shall not be unusual or bizarre. Hair shall not be dyed or streaked in abnormal colors or in two (2) distinctive tones and highlighting should complement the hairs natural color.
  - (h) Ornamentations, scrunchies, bows, or ribbons shall not be worn in the hair, while in uniform. Hair rubber bands, clips, and pins that match the color of the hair are permitted.
  - (i) Shall not be worn in a “pony tail” or similar style unless loose hair is properly secured and does not hang below the cap.
  - (j) Hair that is worn up must be styled in such a manner as to prevent any loose hair.
  - (k) While in civilian attire hair will be neat, clean, trimmed, and present a groomed appearance. Hair shall not interfere with the performance of the employee’s duties. Color and style shall follow above stated criteria.
  - (l) No extreme or abnormal hair styles within these guidelines will be permitted.
  - (m) The wearing of a wig, hair extensions, or hairpiece by female personnel while in uniform or on duty is prohibited except to cover or to accommodate a medical condition or physical disfigurement. If one is worn it must conform to the same standards required for natural hair. It should be of good quality and proper fit and not interfere with a cap or headgear.
  - (n) When working in an undercover capacity hair may be worn as needed in the performance of job duties. However; hair will be worn in a neat, clean, trimmed manner, and present a groomed appearance when at headquarters, at court, participating in or instructing a class. Agents stationed at headquarters are exempt, while carrying out their normal duties.
- (2) Cosmetics
- (a) Females may wear cosmetics if they are conservative and complement the uniform and/or business attire. Eccentric, exaggerated, or trendy cosmetics styles and colors are prohibited.



## DEPARTMENT OF PUBLIC SAFETY POLICIES & PROCEDURES



Some examples of extreme colors include, but are not limited to metallic or dark pinks, purples, greens, and blues.

- (b) False eyelashes are prohibited.
- (c) When working in an undercover capacity, cosmetics may be worn as needed in the performance of job duties. However; cosmetics will be worn in adherence to this policy while at headquarters, at court, participating in or instructing a class. Agents stationed at headquarters are exempt, while carrying out their normal duties.

### (3) Fingernails

- (a) Fingernails shall be clean and trimmed.
- (b) Fingernails shall not extend more than one-quarter inch beyond the tips of the fingers.
- (c) Fingernails may be polished clear or another natural color. No two-tone or multiple tone colors will be accepted.
- (d) Fingernails shall not have designs applied to them.
- (e) When working in an undercover capacity, fingernails may be worn as needed in the performance of job duties. However, fingernails will conform to this policy when at headquarters, court, participating in or instructing a class. Agents stationed at headquarters are exempt, while carrying out their normal duties.

### (4) Jewelry

- (a) Two (2) conservative rings may be worn.
- (b) Necklaces will not be worn in view while in uniform. Religious medals may be worn, provided that they are not visible.
- (c) While in uniform earrings and or piercings will not be worn.
- (d) While in civilian attire any style of conservative earrings may be worn.
- (e) When working in an undercover capacity earrings and/or piercings may be worn as needed in the performance of job duties. However; all earrings and piercings will be removed when at headquarters, at court, participating in or instructing a class. Agents stationed at headquarters are exempt, while carrying out their normal duties.
- (f) For further information on piercings refer to *ADM: 37 Tattoos and Body Piercings*.

- iii) Contact lenses worn by any employee shall not be of a bizarre or unusual color and will not distort the natural appearance of the eye.



## DEPARTMENT OF PUBLIC SAFETY POLICIES & PROCEDURES



### r) Equipment for Commissioned Personnel:

- i) Officers are provided with equipment necessary for completing their duties upon graduation from the State Police Academy. See Attachment B “NMSP Issued Equipment List.”
- ii) Additional equipment may be issued to officers/agents in the field as necessary: this includes equipment specific to different specialty teams. Specialty team commanders will be responsible for ensuring all of their team members have appropriate equipment for their duties. **Officers will be responsible for the maintenance and care of all department equipment issued to them.** Officers are responsible for replacing their leather gear as necessary.
- iii) Upon leaving the department an officer will return all items issued to them in good condition with consideration being given for normal wear and length of its use. Any issued item that is not returned will be replaced by the officer at their expense. The department may allow any officer to retain certain items at its discretion.
- iv) Officers or agents who require equipment to be replaced shall go onto The Insider and fill out the **Lost, Worn, Broken, or Stolen Property Form**. Once the Form is filled out in its entirety, the officer/agent shall submit it as indicated on The Insider.
  - (1) The Training and Recruiting Bureau will review the **Lost, Worn, Broken, or Stolen Property Form** and other pertinent information available to make a determination based on the totality of circumstances associated to the incident. The Training and Recruiting Bureau will make the following determination based on the officer/agent explanation and recommendation of the supervisor:
    - (a) If the property was lost, worn, broken, or stolen and whether it was due to an act of negligence or gross negligence.
    - (b) If gross negligence is determined, the matter will immediately fall under the Chief’s discretion to determine the final resolution.
    - (c) If there is a cost to be incurred by the officer/agent, it will be paid by check or money order within thirty (30) days and made payable to the Department of Public Safety.
    - (d) An employee penalized by suspension or dismissal may appeal the Chief’s decision through the appropriate employee discipline process.





## DEPARTMENT OF PUBLIC SAFETY POLICIES & PROCEDURES



- (2) The Training and Recruiting Bureau will then issue out the new equipment and document the action.
- (3) The Training and Recruiting Bureau will maintain a record of all **Lost, Worn, Broken, or Stolen Property Forms** and equipment replaced.
- (4) If there are any questions regarding the form, equipment, or replacement, an officer/agent may contact the Training and Recruiting Bureau.
  - v) Any officer/agent who wears civilian clothing on a regular basis may be issued additional holsters as well as magazine and handcuff holders that are more appropriate for use with civilian attire.
  - vi) It is important to allow employees to utilize preferred equipment in the performance of their duties. Therefore, personal equipment and apparel may be purchased by the officer if so desired. However, in order to maintain a professional appearance and uniformity among personnel any personal equipment (e.g. knives for utility purposes, sunglasses, belt flashlights, etc.) and/or apparel (e.g. gloves, undershirts, lanyard bolos, etc.) worn on duty must be approved by the district/bureau commander or his/her designee.
  - vii) Officers who are on leave from work in excess of thirty (30) days will adhere to the following procedures for securing/returning equipment. Exceptions to these requirements may be granted by the Chief or his/her designee. Any leave resulting from disciplinary actions will continue to follow the guidelines listed in ADM: 47 Discipline and NMAC 10.5.500.
    - (1) Any department issued vehicle will be returned to Fleet Headquarters in Santa Fe for the duration of the separation from duty. Upon the officer's return they will be re-issued a unit from available fleet resources. Units are not to be kept at district offices.
    - (2) All department issued firearms will be returned to the Training and Recruiting Bureau where they will be turned over to the department armorer.
    - (3) Department issued cell phones shall be turned into the Telecommunications Officer of the Information Technology Bureau at Headquarters.
    - (4) All other department issued equipment will be turned over to the officer's district commander or his/her designee for storage at the district office during the extended absence.



## DEPARTMENT OF PUBLIC SAFETY POLICIES & PROCEDURES



viii) In situations where the leave is less than thirty (30) days and the officer's department issued vehicle is used as a "carpool" unit the following procedures will be followed:

- (1) The officer on leave will remove their issued weapons, personal effects, and any equipment not needed by officers using the unit.
- (2) A supervisor will conduct an inspection of the unit to include any remaining equipment (e.g. stop sticks, radar, shovel, etc.) before allowing the unit to be used for carpool purposes. This will be documented on the standard Officer/Vehicle Inspection Form.
- (3) Once the officer returns to duty and their unit is removed from carpool status a supervisor shall re-inspect the unit to ensure it and all equipment is accounted for and in working order. Any discrepancies will be documented on the Officer/Vehicle Inspection Form utilized for the inspection in Section b.

### **s) General Requirements for Communication Personnel**

- i) The communications bureau uniform will be worn by all Communications Bureau personnel during working hours at DPS Communications Centers, which includes regular shifts, shift extensions, overtime projects and / or special assignments.
- ii) Uniforms shall be kept clean and mended at all times.
- iii) All insignia, patches, nameplates, etc. shall be affixed to, and worn on, the uniform only as described in this policy. Pins shall be worn in accordance to direction given by the Communications Director per policy for Lapel Pins with Communications Bureau LOGO.
- iv) Each Communications Specialist shall maintain a complete supply of uniforms, which will be replenished each fiscal year.
- v) The uniform may not be worn in an attempt to gain favorable considerations in purchasing anything of value or to receive free admissions, gifts, or gratuities. Uniforms shall not be worn for driver's license photographs.
- vi) The uniform shall not be adorned with unauthorized insignia or decorations.
- vii) Hair must be kept neat and clean. The length and hairstyle will not interfere with job duties.
- viii) Fingernails will be kept neat and clean. The length of fingernails must not interfere with the employee's job duties. If it determined by a



## DEPARTMENT OF PUBLIC SAFETY POLICIES & PROCEDURES



- communications supervisor that the length of fingernails inhibits the employee to perform his/her duties, the supervisor may request the employee be sent for a typing evaluation.
- ix) Facial piercings are allowed, but must be kept clean and unobtrusive.
  - x) Any tattoos of a vulgar nature or defies the standard of conduct must be covered while in a communications uniform. This includes, but is not limited to, drug or alcohol related, gang affiliated, or sexually oriented tattoos.
  - xi) The uniform shirts will be returned when the employee retires, resigns or is terminated.**
- t) Communications Uniform Option “A”**
- i) Option “A” Shirt: The Option “A” shirt is a blue in color polo style shirt with either a gold or silver embroidered Communications Logo.
    - (1) Communications Specialists with fewer than five years of service with the Communications Bureau will display a silver logo.
    - (2) Communications Specialists with more than five years of service with the Communications Bureau will display a gold logo.
  - ii) The option “A” shirt will be worn on weekdays with jeans or any color dress pants. No sweatpants, shorts, skirts, or dresses are authorized.
  - iii) Dress shoes or conservative tennis shoes will be worn. No open toed shoes are authorized. No heels taller than one inch will be authorized.
  - iv) During the months of October 1st to March 30th a long sleeved navy, white, black or gray shirt may be worn under the polo.
- u) Communications Uniform Option “B”**
- i) Option “B” shirt: The option “B” shirt is any Communications Bureau issued shirt, with the Communications Bureau logo.
  - ii) The option “B” shirt may be worn on weekends with jeans or any color dress pants. No sweatpants, shorts, skirts, or dresses are authorized.
  - iii) Dress shoes or conservative tennis shoes will be worn. No open toed shoes are authorized. No heels taller than one inch will be authorized.
  - iv) During the months of October 1st to March 30th a long sleeved navy, white, black or gray shirt may be worn under the polo.
- v) Wearing of the Pins for Communications Personnel – Will wear pins only in the following manner:**



## DEPARTMENT OF PUBLIC SAFETY POLICIES & PROCEDURES



- i) Silver DPS pins will be worn by communication specialists who have passed the PST academy and have one (1) year of service with DPS.
- ii) Gold DPS pins will be worn by communication specialists that have five (5) years of service with DPS.
- iii) Gold Milestone pins will be worn by communication specialists that have been a communication specialist with DPS for five (5), ten (10), fifteen (15), twenty (20), or twenty-five (25) years.
- iv) Gold Supervisor pins will be worn by communication specialist supervisors.
- v) All pins will be worn on the right side of the shirt (as it is worn) opposite of the communications emblem.
- vi) The DPS pin (silver or gold) will be the first pin right of the buttons. It will be placed so the bottom of the pin is 2 inches above the lowest portion of the stitched area encompassing the buttons, and the inside of the pin is 2 inches right of the stitched area encompassing the buttons.
- vii) The Milestone pin will be placed at the same height, right of the DPS pin with  $\frac{1}{2}$  inch in between.
- viii) The Supervisor pin will be placed at the same height, right of the Milestone pin with  $\frac{1}{2}$  inch in between.
- ix) The following diagrams are the proper procedures for the wearing of pins:

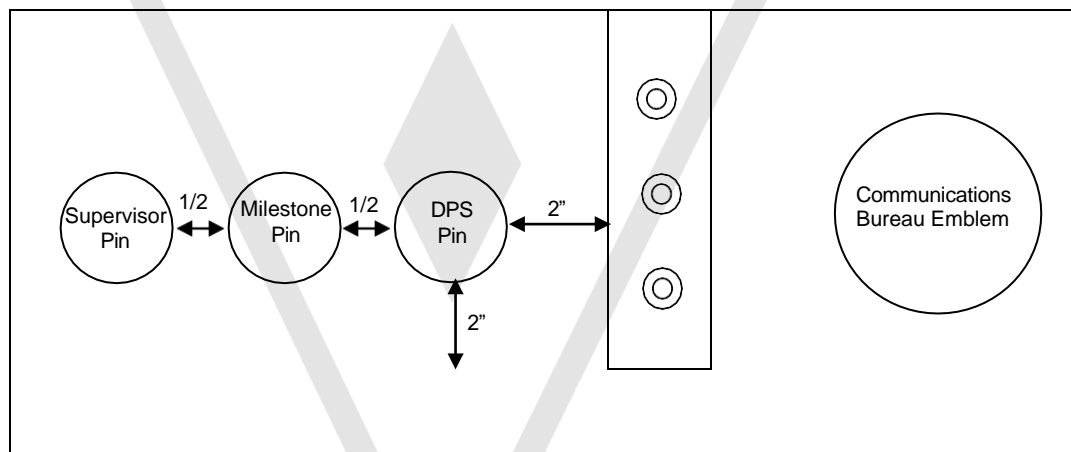

### w) Reporting to work outside the communications center.

When reporting to work outside of the Communications Center, including training, meetings, etc. Communications personnel will wear the Option "A" Communications Uniform or will dress in business attire, including dress slacks, trousers, blouses, dress shirts, polo shirts and sweaters.



## DEPARTMENT OF PUBLIC SAFETY POLICIES & PROCEDURES



### x) Reporting for an ON-DUTY ride along

- i) When Reporting for an on-duty ride along, members will wear the Option "A" Communications Uniform without holes and close-toed, non-high heeled shoes.
- ii) Department issued identifications badges shall be worn during all on-duty ride along.

y) **Cellphones:** Cellular phones will be issued by the Department of Public Safety to a limited number of personnel. This includes all members of the Investigations Bureau and command staff of the rank Lieutenant and above. Other personnel may be issued departmental cellphones at the discretion of the Chief. All departmental personnel who receive department issued cellphones will be responsible for maintaining and keeping them in good working order. Any equipment problems should be reported as soon as practical to the employee's immediate supervisor. Cellphones may be used as an alternative form of communication, but should not be depended on as the sole form of communication. Cellphone usage will be monitored on a monthly basis and any excessive activity will be addressed through the chain of command. Pagers may also be issued by the department as necessary.

### 7) ATTACHMENTS

- a) NMSP Uniform Photos
- b) NMSP Issued Equipment List

### 8) APPROVAL

APPROVED BY: s/ Jason R. Bowie DATE: January 20, 2025  
DPS Cabinet Secretary